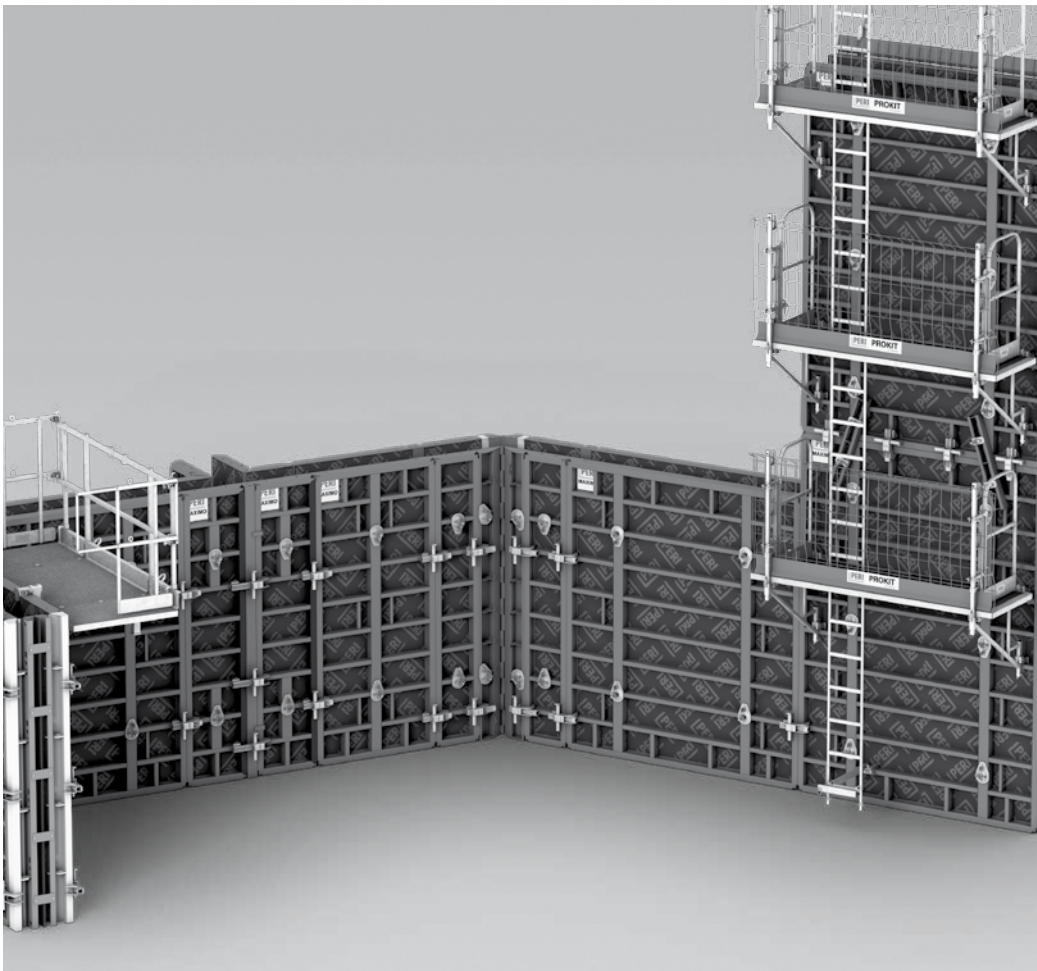


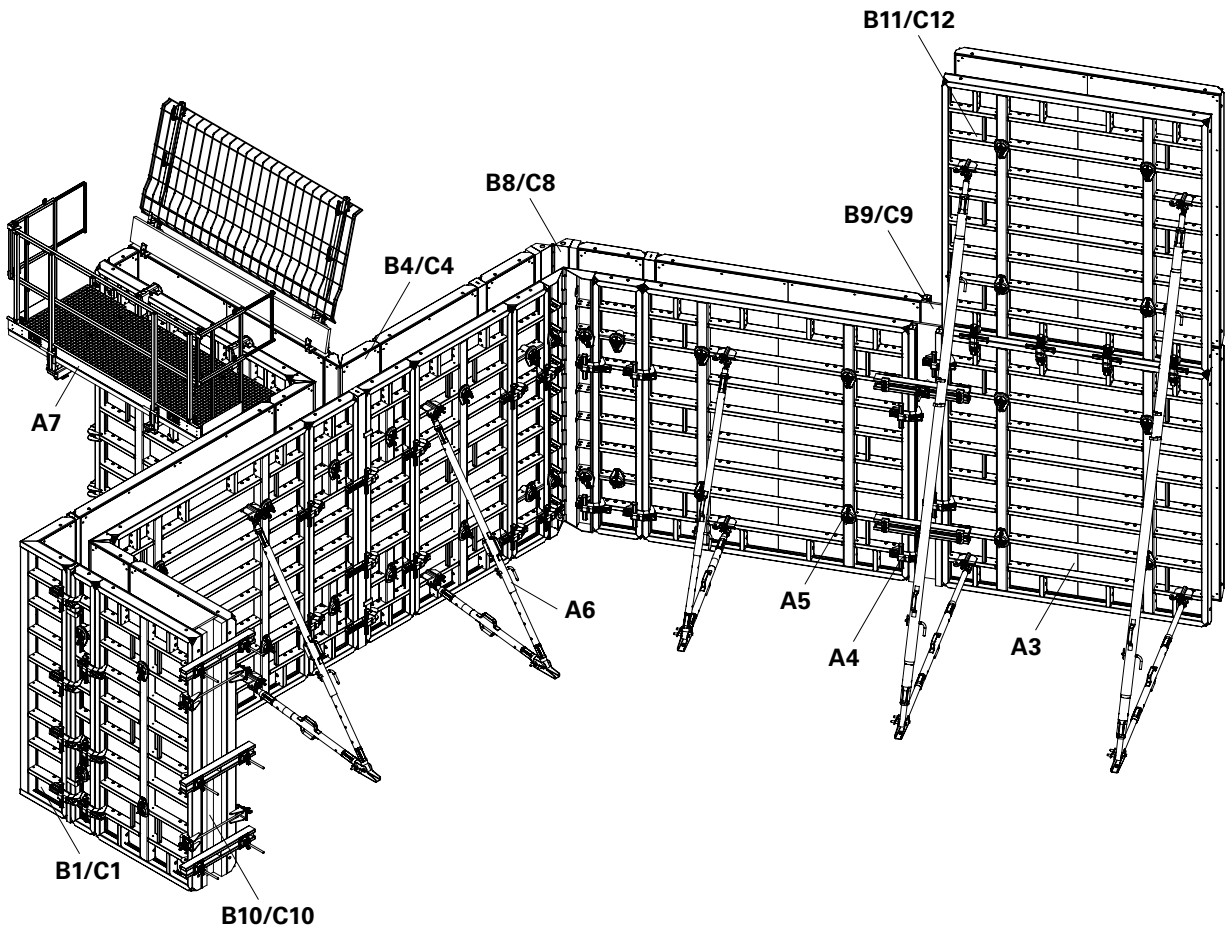
MAXIMO MX 15

Panel Formwork 270 | 330

Instructions for Assembly and Use – Standard Configuration – Issue 04 | 2018




Main components





- A3 Panels
- A4 Panel Connections
- A5 Tie Technology
- A6 Push-Pull Props, Kickers
- A7 Working and Concreting Scaffold
- B1/C1 90° Corners
- B4/C4 90° T-junctions
- B9/C9 Length Compensations
- B8/C8 75° to 165° Corners
- B10/C10 Stopend Formwork
- B11/C12 Height Extensions


Key

Pictogram | Definition

 Danger / Warning / Caution


 Information

 To be complied with

 Load-bearing point


 Visual check

 Tip

 Correct application

 Misapplication

Arrows

 Arrow representing an action

Safety instruction categories

The safety instructions alert site personnel to the risks involved and provide information on how to avoid these risks. Safety instructions are featured at the beginning of the section or ahead of the instructions, and are highlighted as follows:

Danger

This sign indicates an extremely hazardous situation which, if not avoided, will result in death or serious injury.

Warning

This sign indicates a hazardous situation which, if not avoided, could result in death or serious injury.

Caution

This sign indicates a hazardous situation which, if not avoided, could result in minor or moderate injury.

Information

This sign indicates warning of situations whereby failure to observe the information can result in material damage.

Setting-up the safety instructions

Signal word

Type and source of the danger!
Consequences of non-compliance.
⇒ Avoidance measures

Dimension specifications

Dimensions are usually given in cm. Other measurement units, e.g. m, are shown in the illustrations.

Conventions

- Instructions are numbered with: 1., 2., 3.
- The result of an instruction is shown by: →
- Position numbers are clearly provided for the individual components and are given in the drawing, e.g. **1**, in the text in brackets, for example (1).
- Multiple position numbers, i.e. alternative components, are represented with a slash: e.g. **1 / 2**.

Presentational reference

The illustration on the front cover of these instructions is understood to be a system representation only. The assembly steps presented in these Instructions for Assembly and Use are shown in the form of examples with only one component size. They are valid accordingly for all component sizes contained in the standard configuration.

For a better understanding, detailed illustrations are partly incomplete. Safety installations which have possibly not been included in these detailed drawings must nevertheless still be available.

Overview

Key	2
Main components	3

Introduction

Target groups	6
Additional technical documentation	6
Intended use	7
Instructions on use	7
Cleaning and maintenance instructions	8

Safety instructions

Cross-system	9
System-specific	11

Section A – System components

A1 Storage and transportation	
Stacking Device MX	12
Unloading the Stacking Devices	13
Setting down panels individually	14
Transporting stacks without Stacking Devices	16
Putting loads into the Stacking Device	18
Stacking Aids MXI and MXA	19
Stacking Aid MXI	19
Stacking Aid MXA	19
Stacking Aid MX Flat	20
A2 Standard operating sequence	
Assembling the primary formwork	21
Mounting the closing formwork	22
Striking and moving	22
A3 Panels	
Panel overview	24
Assembly	26
Connection possibilities	27
A4 Panel connections	
Alignment Coupler BFD	28
Compensation Walers	30
A5 Tie technology	
Tie System MX 15	31
Tie System DW 15	34
Tie System DW 20	37
Inclined ties	38
Closing tie points	39
A6 Push-Pull Props, Kickers	
Brace Connector	42
Base Plate RS	43
Push-Pull Props and Kickers	44
A7 Working and concreting scaffolds	
Bracket System – MAXIMO MXK	47
Scaffold Bracket TRG 80 and TRG 120	48
Concreting Platform MX	50
Concreting Platform TRIO 120 x 270	58
Handrail Post Holder MX	62
Guardrails with boards	68
A8 Downward extensions	
Downward extension panels	70
Arrangement of panel connections	71

A9 Parapets, foundations, beams	
Tension and Compression Brace	72
Tie System DW 15	75
Foundation Strap TRIO	75
A10 Height offsets	77
A11 Shaft Corner MXSE	
Panel heights	78
Crane suspension	79
Shuttering	80
Striking	81
Shaft with two Shaft Corners MXSE	82
Shaft with four Shaft Corners MXSE	83
Wall thicknesses	84
Height extensions	85
A12 Wall connections	
Obtuse wall connections	86
Vertical wall connections	86
Horizontal wall connections	87
A13 Magnet Cone MX 15	
Installation	88
Removal	89
Closing the cone openings	90
A14 Sealing replacement	
Removing the sealing	91
Inserting the sealing	92

Section B – Height 270

B1 90° corners with	
Inside Corner MXI 270 x 50/20	
Wall thicknesses 15 – 40 cm	94
Wall thickness 60 cm	96
Wall thickness 80 cm	98
B2 90° corners with	
Inside Corner MXI 270 x 60	
Wall thicknesses 15 – 30 cm	100
Wall thicknesses 30 – 40 cm	101
Wall thickness 60 cm	104
Wall thickness 80 cm	106
B3 Panel connections following 90° Corners	108
B4 90° T-junctions with	
Inside Corner MXI 270 x 50/20	
Wall thicknesses 15 – 40 cm	110
B5 90° T-junctions with	
Inside Corner MXI 270 x 60	
Wall thicknesses 15 – 40 cm	112
B6 Panel connections following 90° T-junctions	114
B7 Wall offsets	
Wall offsets ≤ 20 cm	116
Wall offsets 20 – 28 cm	117
Wall offsets 28 – 38 cm	118
Wall offsets 38 – 50 cm	119
Wall offsets 50 – 65 cm	120
Wall offsets 65 – 79 cm	121
Wall offsets 65 – 95 cm	122
Wall offsets 95 – 124 cm	123

B8	75° to 165° corners with Articulated Corners MXGI 270 and 270	
	75° corners	124
	105° to 150° corners	125
	165° corners	126
B9	Length compensations	
	Wall Thickness Compensator WDA MX 270	127
	Filler Profile TPP	128
B10	Stopend formwork	
	Stopend Waler	129
	Stopend Tie and Compensation Waler	131
	Alignment Coupler BFD	132
	Stopend panel reinforcement without Water Bar Installation MT	133
	Stopend panel reinforcement with Water Bar Installation MTF	135
B11	Extensions	
	Extension guidelines	137
B12	Shaft formwork	
	Shaft Corner MXSE 270	140

Section C – Height 330

C1	90° corners with Inside Corner MXI 330 x 50/20	
	Wall thicknesses 15 – 40 cm	142
	Wall thickness 60 cm	144
	Wall thickness 80 cm	146
C2	90° corners with Inside Corner MXI 330 x 60	
	Wall thicknesses 15 – 30 cm	148
	Wall thicknesses 30 – 40 cm	149
	Wall thickness 60 cm	152
	Wall thickness 80 cm	154
C3	Panel connections following 90° corners	156
C4	90° T-junctions with Inside Corner MXI 330 x 50/20	
	Wall thicknesses 15 – 40 cm	158
C5	90° T-junctions with Inside Corner MXI 330 x 60	
	Wall thicknesses 15 – 40 cm	160
C6	Panel connections following 90° T-junctions	162
C7	Wall offsets	
	Wall offsets ≤ 20 cm	164
	Wall offsets 20 – 28 cm	165
	Wall offsets 28 – 38 cm	166
	Wall offsets 38 – 50 cm	167
	Wall offsets 50 – 65 cm	168
	Wall offsets 65 – 79 cm	169
	Wall offsets 65 – 95 cm	170
	Wall offsets 95 – 124 cm	171
C8	75° to 165° corners with Articulated Corners MXGI 330 and MXGA 330	
	75° corners	172
	105° to 150° corners	173
	165° corners	174

C9	Length compensations	
	Wall Thickness Compensator WDA MX 330	175
	Filler Profile TPP	176
C10	Stopend formwork	
	Stopend Waler	177
	Stopend Tie and Compensation Waler	179
	Alignment Coupler BFD	180
C11	Tension and Compression Brace MX 15-40 / MX 15-100	181
C12	Extensions	
	Extension guidelines	182
C13	Shaft formwork	
	Shaft Corner MXSE 270	186

Components

	MAXIMO MX 15	
	Panel Formwork 270 330	188

Target groups

Contractors

These Instructions for Assembly and Use are designed for contractors who either

- assemble, modify and dismantle the formwork system, or
- use it, e.g. for concreting, or
- allow it to be used for other operations, e.g. carpentry or electrical work.

Competent person

(Construction Site Coordinator)

The Safety and Health Protection Coordinator*

- is appointed by the client,
- must identify potential hazards during the planning phase,
- determines measures that provide protection against risks,
- creates a safety and health plan,
- coordinates the protective measures for the contractor and site personnel so that they do not endanger each other,
- monitors compliance with the protective measures.

Competent person qualified to carry out inspections

Due to the specialist knowledge gained from professional training, work experience and recent professional activity, the competent person qualified to carry out inspections has a reliable understanding of safety-related issues and can correctly carry out inspections. Depending on the complexity of the inspection to be undertaken, e.g. scope of testing, type of testing or the use of certain measuring devices, a range of specialist knowledge is necessary.

Qualified persons

Formwork systems may only be assembled, modified or dismantled by personnel who are suitably qualified to do so. For the work to be carried out, the qualified persons must have received instructions* covering at least the following points:

- Explanation of the plan for the assembly, modification or dismantling of the formwork in an understandable form and language.
- Description of the measures for assembling, modifying or dismantling the formwork.

- Designation of the preventive measures to avoid the risk of persons and objects falling.
- Designation of the safety precautions in the event of changing weather conditions which could adversely affect the safety of the formwork system as well as the persons concerned.
- Details regarding the permissible loads.
- Description of any other risks that are associated with the assembly, modification or dismantling procedures.



- **In other countries, ensure that the relevant national guidelines and regulations in the respective current version are complied with!**
- **If no country-specific regulations are available, it is recommended to proceed according to German guidelines and regulations.**
- **A competent person must be present on site during formwork operations.**

* Instructions are given by the contractor himself or a competent person selected by him.

Additional technical documentation

- Poster: MAXIMO
- Instructions for Assembly and Use
 - MAXIMO MX 18 Panel Formwork 270 | 330
 - MAXIMO MX 18 Panel Formwork 300 | 360
 - MAXIMO Bracket System MXK
 - MAXIMO Platform MXP
- Instructions for Use
 - Lifting Hook MAXIMO 1.5 t
 - Lifting Gear Combi MX
 - Lifting Gear MX
 - Pallets and Stacking Devices
 - Adjusting Bracket MX
 - Pallet Lifting Trolley
 - PERI Bio Clean
- User Information: Concrete Cones with Sealing Compound-3
- Data Sheet: Anchor Bolt PERI 14/20 x 130
- Design Tables 2015 – Formwork and Shoring
- Brochure
 - MAXIMO
 - MAXIMO Bracket System MKK
 - Concreting Platform MX
 - MAXIMO Platform MXP
 - PERI Tie Technology

Intended use

Product description

PERI products have been designed for exclusive use in the industrial and commercial sectors by qualified personnel only.

The MAXIMO Wall Formwork system is a flexible panel formwork made of steel for residential and industrial construction projects.

With MAXIMO, concrete structures, e.g. walls and foundations, can be constructed.

MAXIMO has the following features:

- Well-arranged ties and joints.
- Centrally-positioned tie points for different tie systems. One-sided tie technology with spacing adjustment.
- Panel connections with BFD Alignment Coupler – also in area of ties.
- Rigid external corners for wall thicknesses from 20 – 60 cm.
- Formlining panels are riveted.
- Compatible with PERI TRIO.

Technical data

- Panel heights: 330, 270, 120, 90, 60 and 30 cm
- Panel widths: 240, 120, 90, 60, 45 and 30 cm
- Perm. load of platforms and brackets: 150 kg/m²

Tie Capacities:

MX Tie Systems:

MX15, permissible tie load = 100kN*
MX18, permissible tie load = 140kN*

*Grade 900/1100 tie with factor of safety against ultimate load of 1.92 for MX15 & 2.0 for MX18.

DW Tie Systems:

DW15, permissible tie load = 100kN**
DW20, permissible tie load = 150kN

**Grade FC 900/1050 tie with factor of safety of 1.8 against ultimate load.

Permissible fresh concrete pressure according to DIN 18218

Evenness according to DIN 18202, Table 3, Line 7

Fresh concrete pressure with:		Height	Tie System MX 15* / DW 15	Tie System DW 20 **
Pressure – hydrostatic triangular load		2.70 m	67.5 kN/m ²	67.5 kN/m ²
		3.30 m	80.0 kN/m ²	80.0 kN/m ²
Pressure – constant uniformly distributed load		2.70 m	60.0 kN/m ²	80.0 kN/m ²
		3.30 m	60.0 kN/m ²	80.0 kN/m ²

* Tie System MX 15 is only valid for panel connections with wall thicknesses ≤ 40 cm.

** Tie System DW 20 must be mounted as described in the MAXIMO MX 18 Instructions for Assembly and Use.

Tie System DW 20 (with Steel Waler SRU, through-ties) is valid for all wall thicknesses.

Instructions on use

The use in a way not intended according to the Instructions for Assembly and Use, or any use deviating from the standard configuration or the intended use represents a misapplication with a potential safety risk, e.g. risk of falling.

Only PERI original parts may be used. The use of other products and spare parts is not allowed.

Changes to PERI components are not permitted.

Cleaning and maintenance instructions

In order to maintain the value and operational readiness of the formwork materials over the long term, clean the panels after each use.

Some repair work may also be inevitable due to the tough working conditions.

The following points should help to keep cleaning and maintenance costs as low as possible.

Spray the formwork on both sides with concrete release agent before each use; this allows easier and faster cleaning of the formwork. Spray the concrete release agent very thinly and evenly!

Spray the rear side of the formwork with water immediately after concreting; this avoids any time-consuming and costly cleaning operations.

When used continuously, spray the panel formlining with concrete release agent immediately after striking; then clean by means of a scraper, brush or rubber lip scraper. Important: do not clean formlining made of plywood with high-pressure equipment; this could result in the formlining being damaged.

Fix box-outs and mounting parts with double-headed nails; as a result, the nails can easily be removed later, and damage to the formlining is largely avoided.

Close all unused tie holes with plugs; this eliminates any subsequent cleaning or repair work. Tie holes accidentally blocked with concrete are freed by means of a steel pin from the formlining side.

When placing bundles of reinforcement bars or other heavy objects on horizontally-stored formwork elements, suitable support, e.g. square timbers, is to be used; as a result, impressions and damage to the formlining are largely avoided.

Internal concrete vibrators should be fitted with rubber caps if possible; as a result, any damage to the formlining is reduced if the vibrator is accidentally inserted between the reinforcement and formlining.

Never clean powder-coated components, e.g. elements and accessories, with a steel brush or hard metal scraper; this ensures that the powder coating remains intact.

Use spacers for reinforcement with large-sized supports or extensive areas of support; this largely avoids impressions being formed in the formlining when under load.

Mechanical components, e.g. spindles or gear mechanisms, must be cleaned of dirt or concrete residue before and after use, and then greased with a suitable lubricant.

Provide suitable support for the components during cleaning so that no unintentional change in their position is possible.

Do not clean components suspended on crane lifting gear.

Cross-system

General

The contractor must ensure that the Instructions for Assembly and Use supplied by PERI are available at all times and understood by the site personnel.

These Instructions for Assembly and Use can be used as the basis for creating a risk assessment. The risk assessment is compiled by the contractor. These Instructions for Assembly and Use do not replace the risk assessment!

Always take into consideration and comply with the safety instructions and permissible loads.

For the application and inspection of PERI products, the current safety regulations and guidelines valid in the respective countries must be observed.

Materials and working areas are to be inspected on a regular basis, especially before each use and assembly, for:

- signs of damage,
- stability and
- function.

Damaged components must be exchanged immediately on site and may no longer be used.

Safety components are to be removed only when they are no longer required.

Components provided by the contractor must conform with the characteristics required in these Instructions for Assembly and Use as well as all valid construction guidelines and standards. Unless otherwise indicated, this applies in particular to:

- timber components: Strength Class C24 for Solid Wood according to EN 338.
- scaffold tubes: galvanised steel tubes with minimum dimensions of $\varnothing 48.3 \times 3.2$ mm according to EN 12811-1:2003 4.2.1.2.
- scaffold tube couplings according to EN 74.

Deviations from the standard configuration are only permitted after a further risk assessment has been carried out by the contractor.

On the basis of this risk assessment, appropriate measures for working and operational safety as well as stability are to be determined.

Corresponding proof of stability can be provided by PERI on request if the risk assessment and resulting measures to be implemented are made available.

Before and after exceptional occurrences that may have an adverse effect regarding the safety of the formwork system, the contractor must immediately

- create another risk assessment, with appropriate measures for ensuring the stability of the formwork system being carried out based on the results,
- arrange for an extraordinary inspection to be carried out by a competent person qualified to do so. The aim of this inspection is to identify and rectify any damage in good time in order to guarantee the safe use of the formwork system.

Exceptional occurrences can include:

- accidents,
- longer periods of non-use,
- natural events, e.g. heavy rainfall, icing, heavy snowfall, storms or earthquakes.

Assembly, modification and dismantling work

Assembly, modification or dismantling of formwork systems may only be carried out by qualified persons under the supervision of a competent person. The qualified persons must have received appropriate training for the work to be carried out with regard to specific risks and dangers.

On the basis of the risk assessment and the Instructions for Assembly and Use, the contractor must create installation instructions in order to ensure safe assembly, modification and dismantling of the formwork system.

The contractor must ensure that the personal protective equipment required for the assembly, modification or dismantling of the formwork system, e.g.

- safety helmet,
- safety shoes,
- safety gloves,
- safety glasses,

is available and used as intended.

If personal protective equipment against falling from a height (PPE) is required or specified in local regulations, the contractor must determine appropriate attachment points on the basis of the risk assessment.

The PPE against falling to be used is determined by the contractor.

The contractor must

- provide safe working areas for site personnel which are to be reached through the provision of safe access ways. Areas of risk must be cordoned off and clearly marked.
- ensure the stability during all stages of construction, in particular during assembly, modification and dismantling operations.
- ensure and prove that all loads can be safely transferred.

Utilisation

Every contractor who uses or allows formwork systems or sections of the formwork to be used, has the responsibility for ensuring that the equipment is in good condition.

If the formwork system is used successively or at the same time by several contractors, the health and safety coordinator must point out any possible mutual hazards and all work must be then coordinated.

System-specific

Retract components only when the concrete has sufficiently hardened and the person in charge has given the go-ahead for striking to take place.

Anchoring is to take place only if the anchorage has sufficient concrete strength.

During striking, do not tear off the formwork elements with the crane.

If a storm warning is given, additional push-pull props are to be attached or other bracing measures are to be carried out along with implementing the details contained in the PERI design tables.

Storage

PERI provides Stacking Devices for the safe storage of panels. The corners of the panels are placed in four Stacking Devices.

Stacking Device MX



Warning

Risk of injury!

⇒ Only panels of the same size are to be transported in one stack!

⇒ Use Lifting Gear Combi or 4-sling lifting gear.

On each Stacking Device, attach a hook (11a) to one load-bearing point (1a).

→ Four load-bearing points (Fig. A1.04)

⇒ Always follow the Instructions for Use:

- Pallets and Stacking Devices
- Lifting Gear Combi MX



- Stacking Devices (1) (Fig. 1.01)
 - are suitable for lifting by crane or forklift,
 - can also be moved with the PERI Pallet Lifting Trolley,
 - can be lifted using the longitudinal as well as front sides.
- Place the Stacking Aid (2) as spacer between the panels. (Fig. 1.02)

Pos.	Components	Item no.
1	Stacking Device MAXIMO 115058	
1a	Load-bearing point	
1.1	Vertical support plate	
1.2	Rectangular tube	
2	Stacking Aid MX	113019
11	Lifting Gear Combi MX	117321
11a	Load hook	

Perm. load-bearing capacity

650 kg/device = 2.6 t/stack

Number of panels per stack

2 – 5 MAXIMO panels of one size

Angle of inclination of crane

sling $\beta \leq 33^\circ$

4-sling lifting gear L = 4.0 m (Fig. A1.03)

Max. stacking height

3 Stacking Devices on top of each other

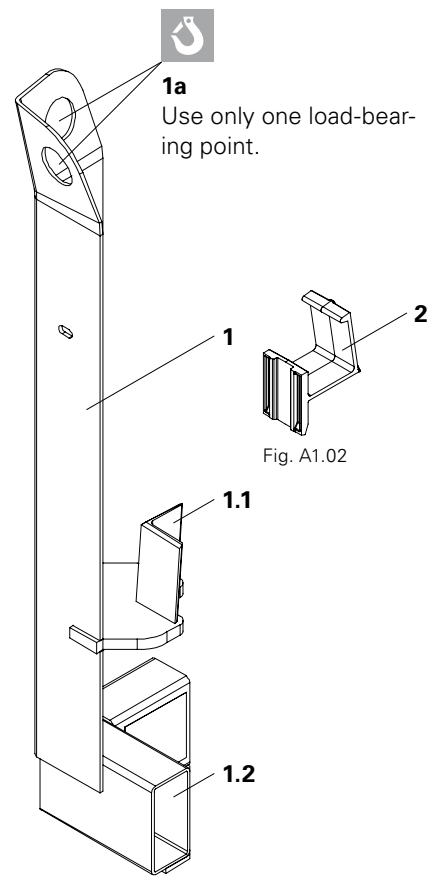


Fig. A1.01

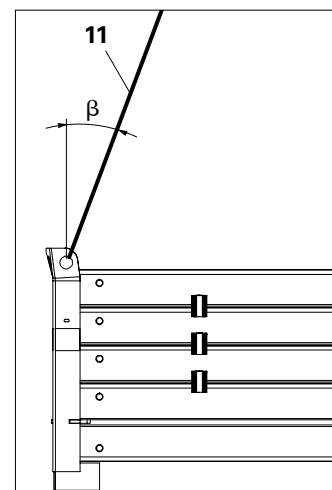


Fig. A1.03

Transportation

PERI provides lifting accessories such as Lifting Gear Combi MX (11) for ensuring safe transportation.



Warning

Risk of injury!

- ⇒ Risk of slipping! The panels should not be treated with concrete release agent immediately before transport.
- ⇒ Use original PERI storage and transport systems, e.g. crate pallets, pallets or stacking devices.
- ⇒ Ensure transport units are correctly stacked and secured.
- ⇒ Use PERI lifting accessories and lifting gear.
- ⇒ Use the designated load-bearing points on the components.
- ⇒ Store and transport components ensuring that no unintentional change in their position is possible. Detach lifting accessories and lifting gear from the lowered components only if they are in a stable position and no unintentional change is possible.
- ⇒ Do not drop the components.
- ⇒ During the moving procedure, ensure that components are picked up and set down so that any unintentional falling over, falling apart, sliding, falling down or rolling is avoided.
- ⇒ During moving operations, no persons are allowed to remain under the suspended load.
- ⇒ The access areas on the jobsite must be free of obstacles and tripping hazards as well as being slip-resistant.
- ⇒ For transportation, the surface used must have sufficient load-bearing capacity.

Unloading the Stacking Devices

Unload the stacks using the crane with the help of the Lifting Gear Combi (11) or 4-sling lifting gear. (Fig. A1.04)

1. Attach load hooks (11a) to the load-bearing points (1a) of the Stacking Device – 4x. (Fig. A1.01 + A1.04)
2. Lift the stack with the crane and place on the ground.

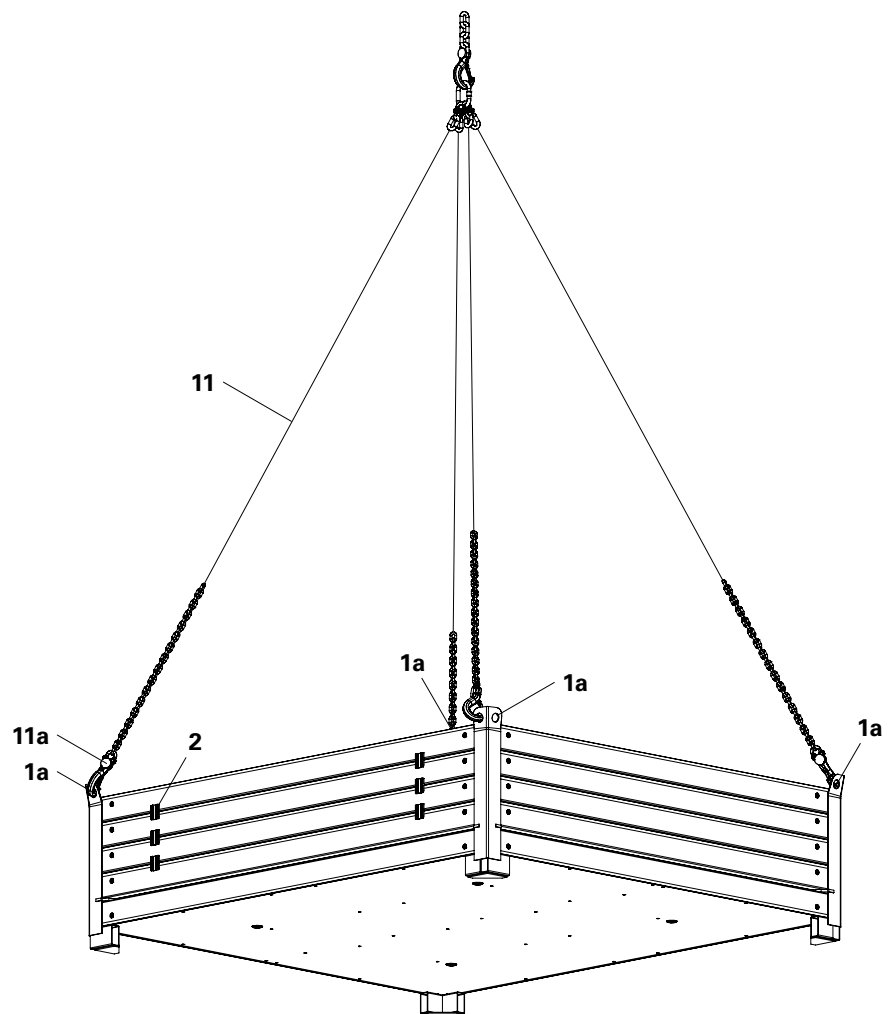


Fig. A1.04

Setting down panels individually



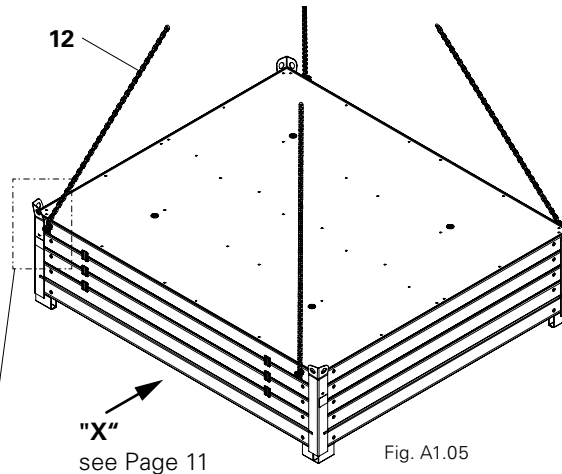
Warning

Risk of crushing!

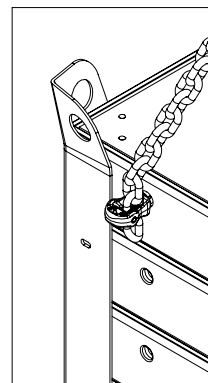
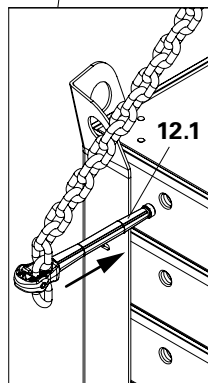
- ⇒ Use personal protective equipment (PPE) when turning the panels.
- ⇒ Only mount lifting hook when the panel is horizontally positioned on the ground! (Fig. A1.07)
- ⇒ Always follow the Instructions for Use!
 - Lifting Gear MX
 - Lifting Gear Combi MX
 - Lifting Hook MAXIMO 1.5 t



- Remove panels (10) individually or max. 4 panels as a stack from the Stacking Devices. (Fig. A1.06)
- Turning the panels over is only necessary if the formlining side is facing upwards after it has been lowered. (Fig. A1.05)



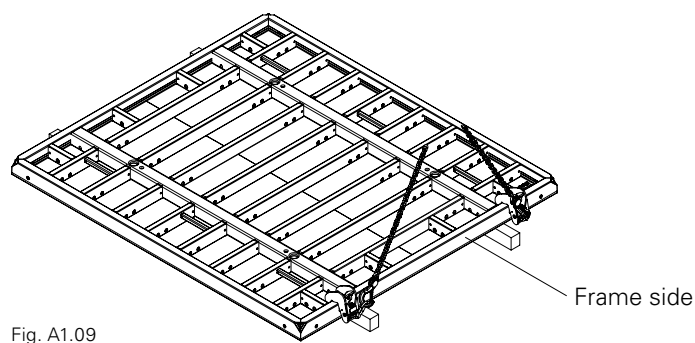
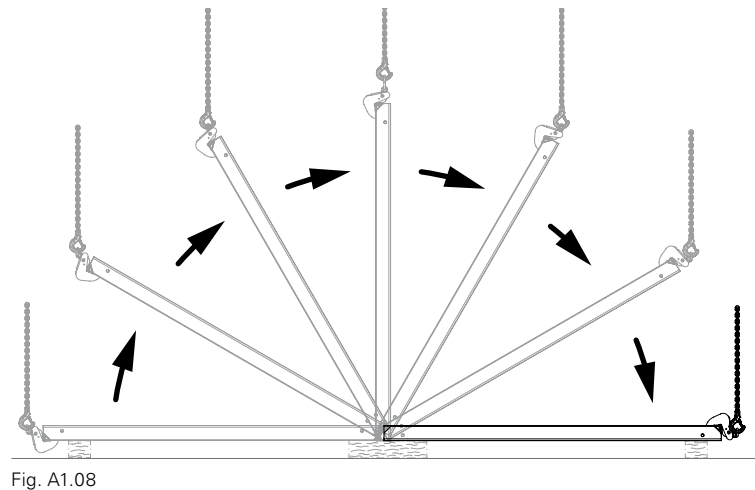
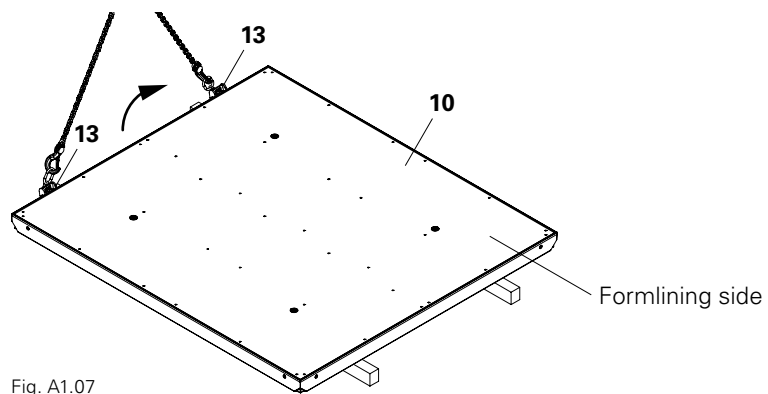
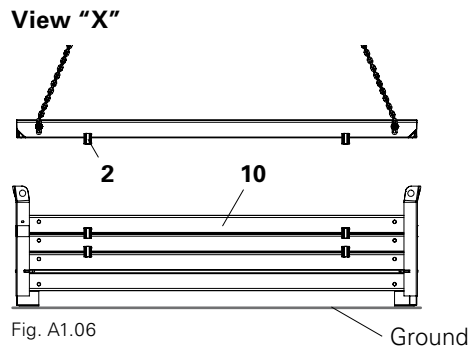
Pos.	Components	Item no.
2	Stacking Aid MX	113019
10	Panel MX Height x width according to size	
11	Lifting Gear Combi MX (alternative)	117321
12	Lifting Gear MX	117322
12.1	Locking Pin	
13	Lifting Hook MAXIMO 1.5 t	115168



Instead of the lifting gear (12), the Locking Pins of the Lifting Gear Combi (11) can also be inserted into the drilled holes of the panels.

Assembly

1. Insert Locking Pins (12.1) of the lifting gear (12) into the drilled holes of the top panel as far as possible - 4x. (Fig. A1.05 + A1.05a + A1.05b)
2. Attach lifting gear to the crane.
3. Lift panel out of the Stacking Device. (Fig. A1.06)
4. Remove Stacking Aid MX (2) - 4x per panel.
5. Place timbers on the ground.
6. Position panel on the timbers.
7. Remove Locking Pins (12.1) - 4x.
8. Attach Lifting Hook (13) to the panel - 2x. (Fig. A1.07)
9. Turn panel, i.e. pull upwards while suspended on the crane using the Lifting Hook until the panel is in a vertical position, and then slowly lower onto the timbers with the formlining facing downwards. (Fig. A1.07 + A1.08 + A1.09)
Ensure that the chains are sufficiently and evenly tensioned.
10. Repeat Points 1 to 9 for the next panel in the stack and continue through to the last panel which is positioned with the frame side facing upwards.
11. Lift out last panel; for this, repeat Points 1 to 7.



Transporting stacks without Stacking Devices

As an alternative to the Stacking Devices, there is the possibility of transporting up to a max. of 5 panels placed on top of each other as a stack.

For securing:

- Tie rod and wingnuts - 2x.
(Fig. A1.10 + A1.11) Thereby the tie rod must be approx. 15 cm longer than the height of the stack.
- Steel straps (not shown).

Pos.	Components	Qty.
12	Lifting Gear MX	1x
25	Tie Rod DW 15	2x
44	Wingnut DW 15	2x

Secure panels with tie rods and wingnuts, and lift out using the lifting gear.

Assembly

1. If necessary, clean tie holes and holes on the side for the Locking Pins.
2. Hold the tie rod (25) against the stack of panels in order to compare the height of the stack with the length of the tie rod.
3. Screw wingnut (44) onto the protruding end of the tie rod. Leave approx. 5 cm play between the stack and wingnut. (Fig. A1.11)
4. Insert the long end of the tie rod into one external tie hole of the panel until it rests against the wingnut.
→ At the bottom, tie rod protrudes approx. 5 cm.
5. Repeat Points 2 + 3.
6. Insert second tie rod (25) into the external tie hole which is positioned diagonally to the first tie rod. (Fig. A1.10) (For a height of 330 cm, the middle holes remain open.)
7. Insert Locking Pins of the lifting gear by hand as far as possible into the holes on the side of the bottom panel - 4x.
→ Due to its design, the Locking Pin is self-securing.

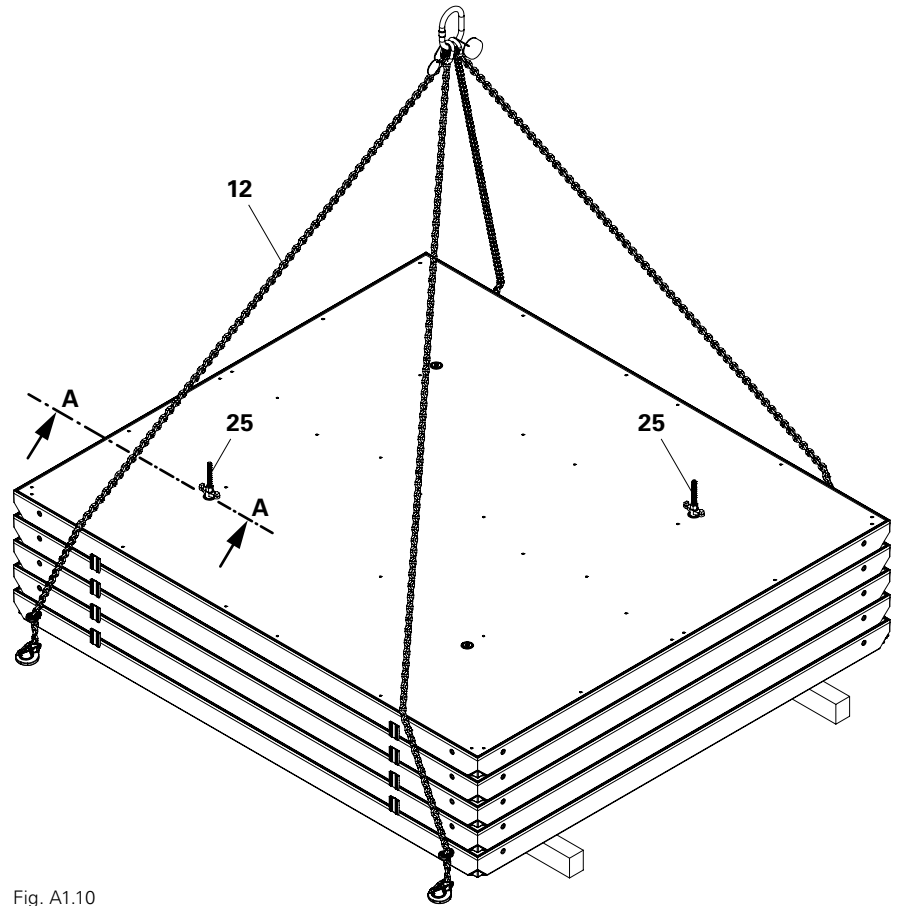


Fig. A1.10



Have all four Locking Pins been completely inserted into the holes?

8. Lift up stack with the crane.
→ The tie rods prevent the panels from moving. (Fig. A1.11)



Do not use the hammer to fix the Locking Pins, only insert by hand.

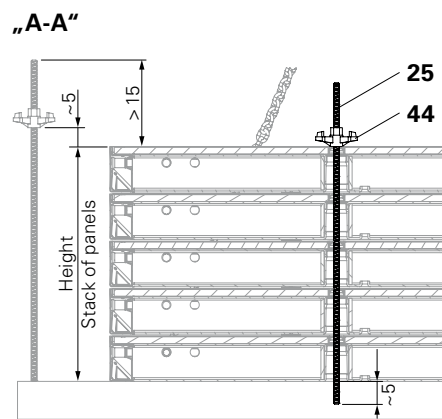


Fig. A1.11

Putting loads into the Stacking Device



Warning

Risk of injury!

- ⇒ Ensure transport units are correctly stacked and secured.
- ⇒ Follow Instructions for Use for Pallets and Stacking Devices.
- ⇒ For reasons of safety, the panels should never be treated with a concrete release agent immediately before transport.



Stacking Devices (1)

- are suitable for lifting by crane or forklift,
- can also be moved with the PERI Pallet Lifting Trolley,
- can be lifted both from the longitudinal and front sides.

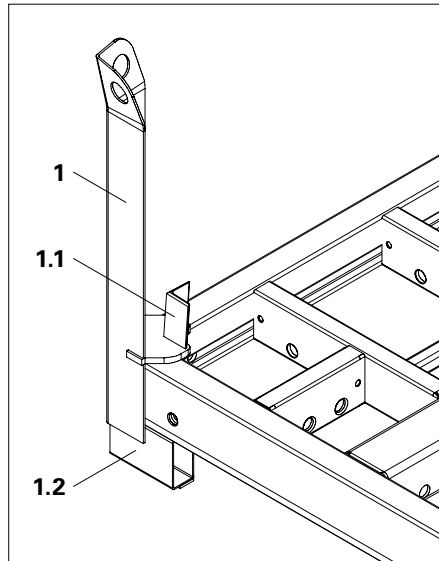


Fig. A1.12

Pos.	Components	Item no.
------	------------	----------

- | | | |
|-----|------------------------|--------|
| 1 | Stacking Device MAXIMO | 115058 |
| 1.1 | Vertical support plate | |
| 1.2 | Rectangular tube | |

Assembly

1. Place the first panel with the formlining facing downwards on the rectangular tubes (1.2). (Fig. A1.12)
2. Place the second panel with the formlining facing upwards into the Stacking Device. (Fig. A1.13)
 - The vertical support plate (1.1) positions the panel and now allows safe transportation of the panels.
3. Position Stacking Aid MX (2) – 2 per longitudinal side.
 - Formlining is protected.
4. Place other panels with the formlining facing upwards.
5. Alternately place Stacking Aid (2) and panels with the formlining facing upwards until the maximum number of panels has been reached.

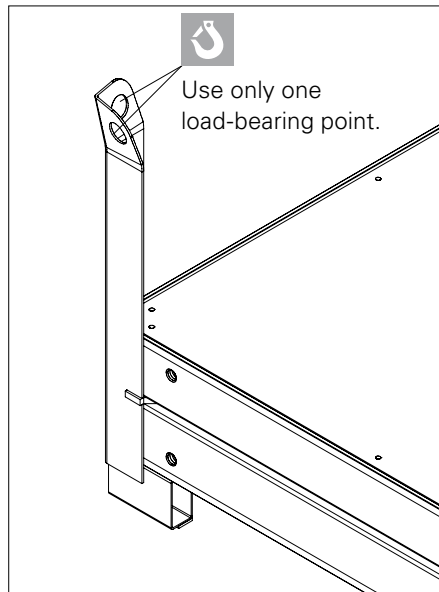


Fig. A1.13

Stacking Aids MXI and MXA

MXI



Note

Material damage!
 ⇒ Use Stacking Aids as transport safety devices only in combination with transportation straps.

Pos.	Components	Item no.
3	Stacking Aid R MXI	118112
4	Stacking Aid L MXI	118110
5	Stacking Aid R MXA	118105
6	Stacking Aid L MXA	118103
7	Stacking Aid MX Flat for Shaft Corner MXSE	118100

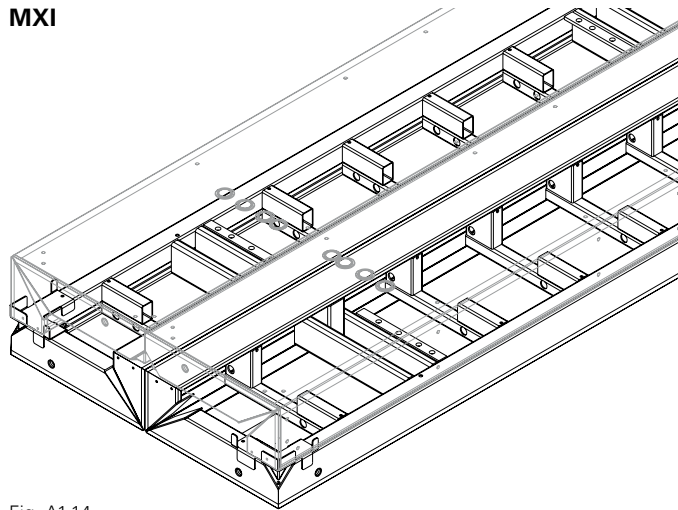


Fig. A1.14

Stacking Aid MXI



Take into account that there are right and left versions.

Inside Corner MXI, height x 50/20

Stack with
 – two shaft corners (not shown).
 – four shaft corners. Install Stacking Aids (3 + 4) only on the corners. (Fig. A1.14)

Inside Corner MXI, height x 60

Stack with
 – two shaft corners (Fig. A1.15).
 – four shaft corners. Install Stacking Aids (3 + 4) only on the corners (not shown).

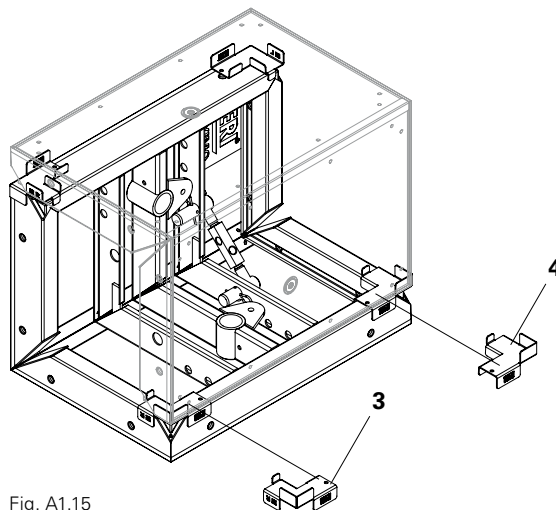


Fig. A1.15

Stacking Aid MXA



Take into account that there are right and left versions.

External corners

MXA height x 45 or MXA height x 35
 (Fig. A1.16)

MXA

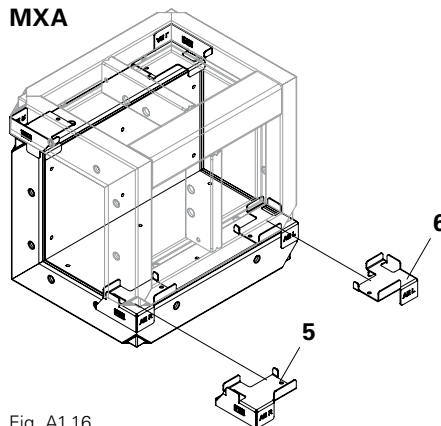


Fig. A1.16

Stacking Aid MX Flat

For Shaft Corners MXSE x height

Stack with

- two shaft corners. Install Stacking Aids (7) on the corners at the top and bottom. (Fig. A1.17)
- four shaft corners. Install Stacking Aids MX Flat (7) only on the corners at the bottom. (Fig. A1.18 + A1.19)

Push back positioning waler for stacking and secure. (Fig. A1.19 + A1.19a + A1.19b)

MX Flat

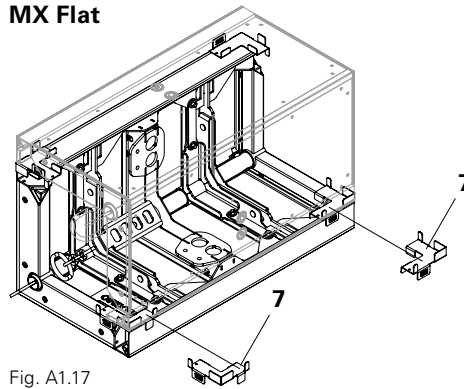


Fig. A1.17

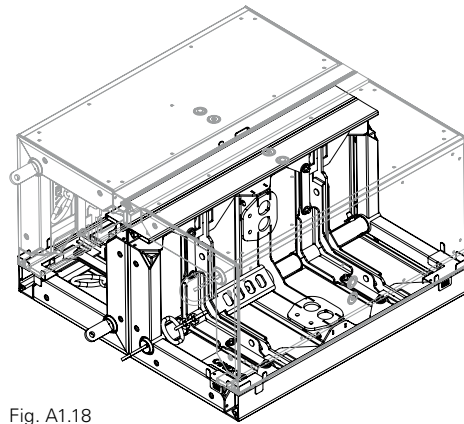


Fig. A1.18



With Shaft Corners MXSE height > 120, turn the top panel. (Fig. A1.19)

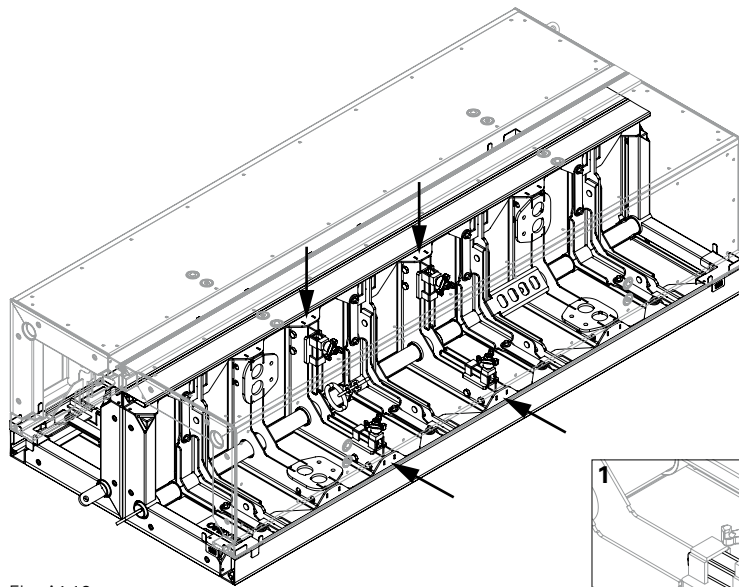


Fig. A1.19

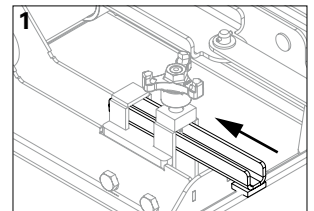


Fig. A1.19a

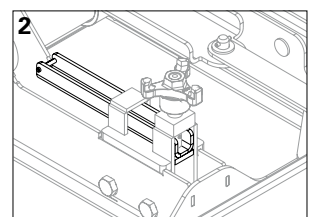


Fig. A1.19b



Always follow the Instructions for Use:

- Lifting Hook MAXIMO 1.5 t
- RS and RSS Push-Pull Props

Assemble primary formwork

Here with working and concreting scaffold

Primary formwork is the formwork with Push-Pull Props independent of the anchoring direction.

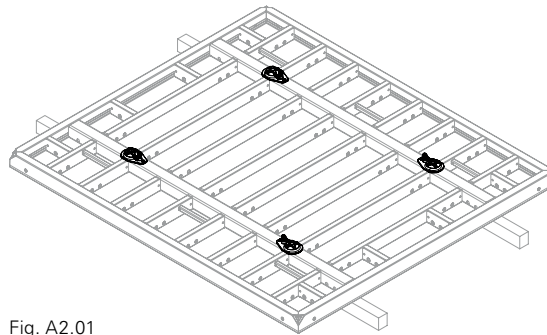


Fig. A2.01



Warning

Risk of injury!

- ⇒ Secure panels with Push-Pull Props to prevent tipping over and counter wind forces.
- ⇒ First secure Push-Pull Props, and then release 2-sling lifting gear.

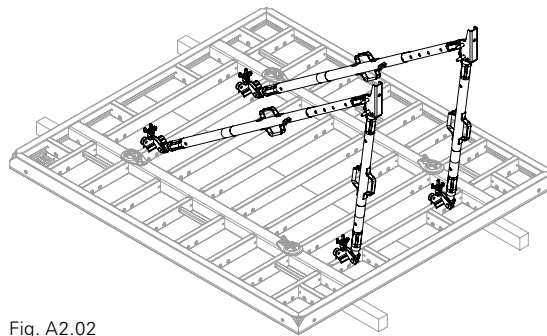


Fig. A2.02

Assembly

1. Mount one articulated nut at each tie point, see Section A5. (Fig. A2.01)
2. Mount Push-Pull Props, see Section A6. (Fig. A2.02)
3. Mount working platform, e.g. MAXIMO MXK Bracket System, see Section A7.
4. Mount Lifting Hook MAXIMO 1.5 t.
5. Attach the 2-sling lifting gear.
6. Erect panel.
7. Transport panel to place of operation by crane. (Fig. A2.03)
8. Secure Push-Pull Props, see Section A6.
9. Release the 2-sling lifting gear.

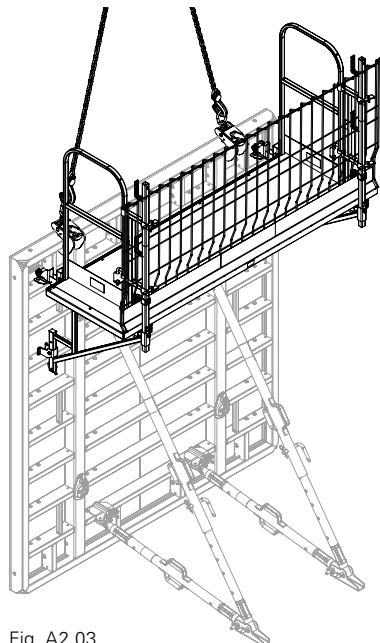


Fig. A2.03



- Forming is carried out from the external or internal corner in the direction of the compensation.
- With panel extensions, the Push-Pull Props collide in part with the working platform. In these cases, mount the working platform on the primary formwork.

Mounting the closing formwork

Here with guardrails on opposite side



Warning

Risk of injury!

- ⇒ Install top tie first.
- ⇒ Release 2-sling lifting gear when all ties have been installed.

Assembly

1. Mount opposing guardrails on the horizontally-positioned panel, see Section A7. (Fig. A2.04)
2. Mount Lifting Hook MAXIMO 1.5 t. (Fig. A2.04)
3. Attach the 2-sling lifting gear.
4. Erect panel.
5. Transport panel to place of operation by crane.
6. Mount ties, see Section A5.
7. Release the 2-sling lifting gear.
8. Mount board under the Side Mesh Barrier. (Fig. A2.05)

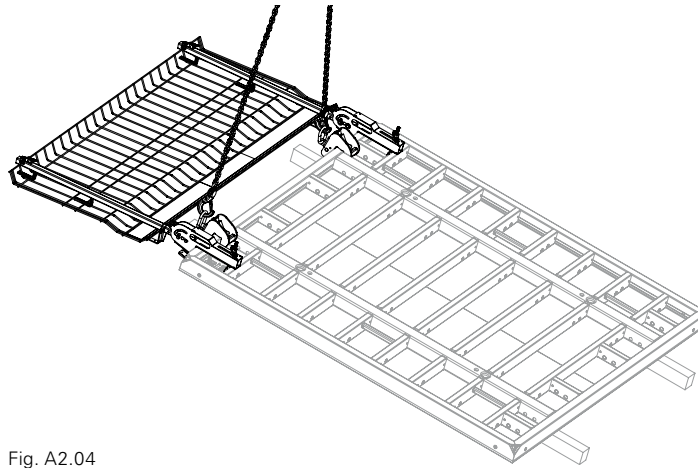


Fig. A2.04

Concreting

From a working platform. (Fig. A2.05)

Striking and moving

From the compensation to the corners.



Warning

Risk of injury!

- ⇒ Concrete strength must be taken into account.
- ⇒ Secure panels against tipping over and wind forces.
- ⇒ Secure Push-Pull Props first, and then release 2-sling lifting gear.

Setting down the closing formwork

1. Remove board from under the Side Mesh Barrier. (Fig. A2.05)
2. Mount Lifting Hook MAXIMO 1.5 t on the panel.
3. Attach the 2-sling lifting gear.
4. Remove ties.
5. Release panel connection, here Alignment Coupler BFD.
6. Release panel from the concrete, e.g. with a stripping bar.
7. Carefully set the panel down and clean.

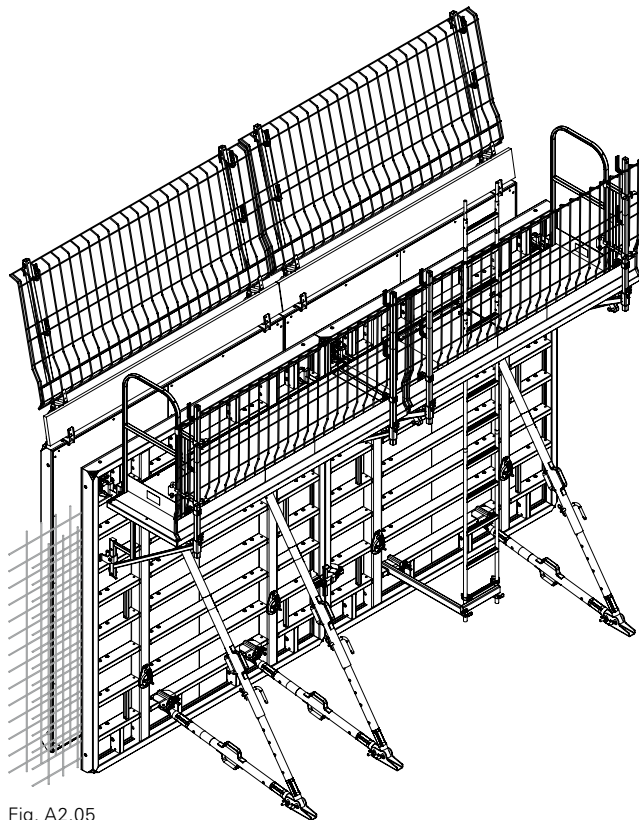


Fig. A2.05

Moving the primary formwork

1. Mount Lifting Hook MAXIMO 1.5 t on the panel.
2. Attach the 2-sling lifting gear.
3. Release panel connection, here Alignment Coupler BFD.
4. Remove anchor bolts of the Push-Pull Props.
5. Panel is
 - released from the concrete, e.g. with the stripping bar,
 - carefully laid down and cleaned,
 - transported to place of operation by crane.
6. Connect panel, here with the Alignment Coupler BFD, see Section A4.
7. Secure Push-Pull Props, see Section A6.
8. Release the 2-sling lifting gear.

Moving the closing formwork

1. Mount Lifting Hook MAXIMO 1.5 t on the panel.
2. Attach the 2-sling lifting gear.
3. Move panel of the closing formwork to the place of operations by crane.
4. Connect panel by means of the Alignment Coupler BFD.
5. Install ties.
6. Release the 2-sling lifting gear.
(Fig. A2.06)

Cleaning

with PERI Bio Clean and release agent spraying equipment.



Follow the PERI Bio Clean operating instructions!

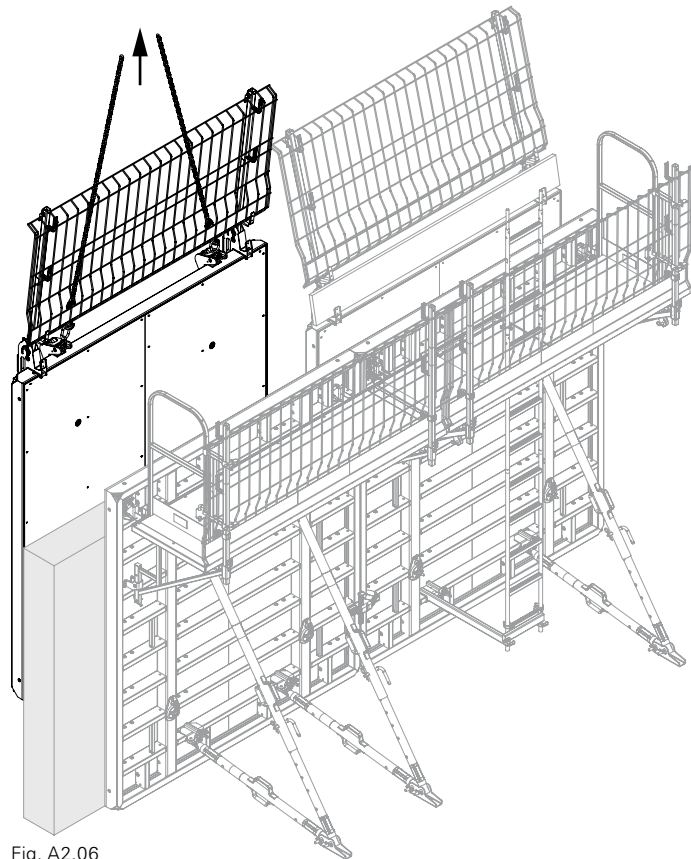


Fig. A2.06

Panel overview

		Width [cm]						Multi Panel MXM 60
		240	120	90	60	45	30	
Height [cm]	30							
	60							
	90							
	120							
	270							
330								

Height [cm]	Width [cm]										
	30	60	90	120	270	330	Articulated Corner				
							Inside Corner MXI 50/20	Inside Corner MXI 60	Outside Corner MXA 35	Outside Corner MXA 45	MXGI inside
30											
60											
90											
120											
270											
330											

Assembly



Warning

Risk of injury!

- ⇒ Do not use the positioning strut (10.5) for transporting with the crane.
- ⇒ Do not use the positioning strut (10.5) as a climbing aid.

Pos. Components

- 10** Panel MX height x width
- 10.1** Tie point with sealing
- 10.2** Panel strut
- 10.3** Connecting holes for scaffold brackets, push-pull-props and other accessories
- 10.4** Levering corner
- 10.5** Positioning strut for positioning the panel
- 10.6** Transportation opening, e.g. for TRIO Stripping Bar
- 10.7** Frame profile
- 10.8** Plywood formlining

(Fig. A3.01 + A3.02 + A3.02a)

Panel width 240 cm

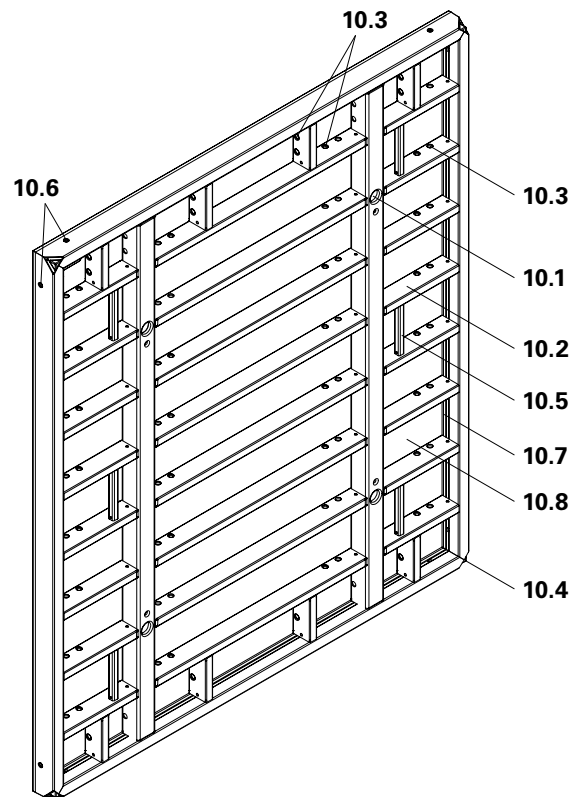


Fig. A3.01

Panel width 120 cm

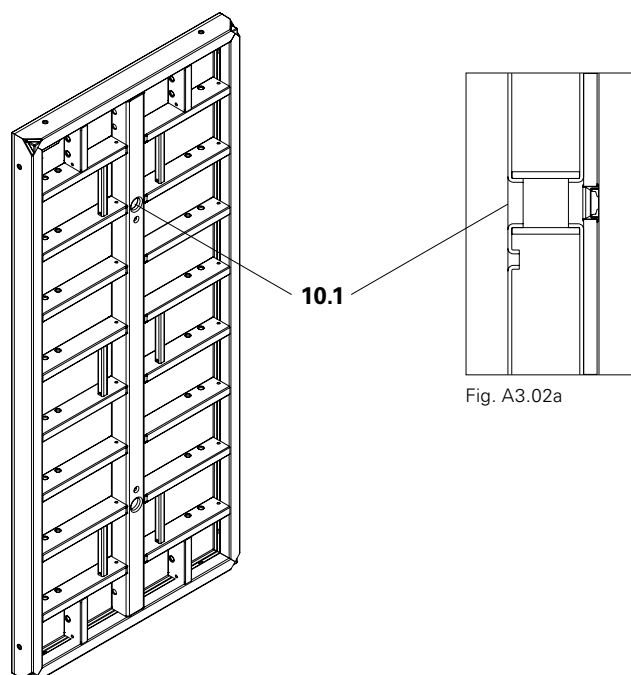


Fig. A3.02a

Fig. A3.02

Connection possibilities

The following are fixed to the connection holes (10.3):

- Prop Connector for connecting the Push-Pull Props, see Section A6. (Fig. A3.05)
- Scaffold Brackets, see Section A7. (Fig. A3.03)
- Compensation Waler MAR, see Section A4.

TRIO Stripping Bar

Item no. 112588

With the TRIO Stripping Bar (97), the MAXIMO panels

- are released from the concrete. (Fig. A3.04a)
- are adjusted. (Fig. A3.04b)

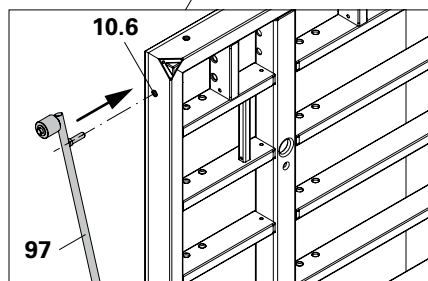
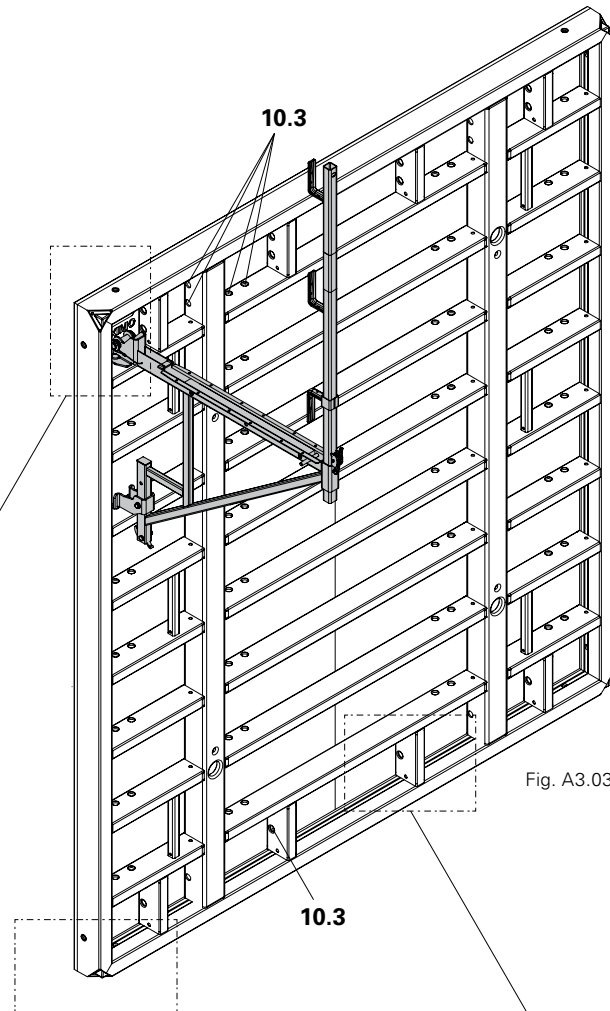


Fig. A3.04a

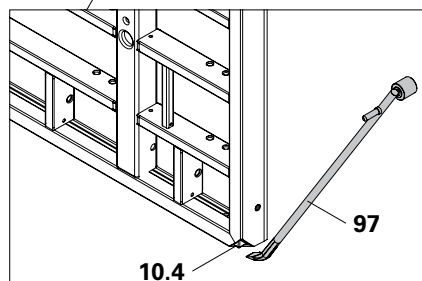


Fig. A3.04b

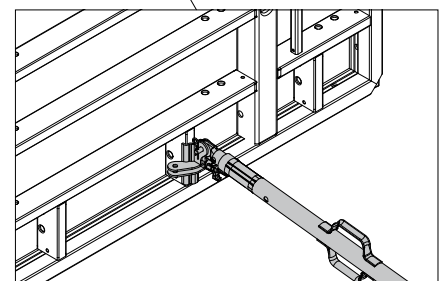


Fig. A3.05

Alignment Coupler BFD

(Fig. A4.01a)

Pos.	Components	Item no.
20	Alignment Coupler BFD	023500

Assembly

1. Place wedge in upper end position.
2. Open sliding part. (Fig. A4.01b)
3. Place BFD on panel strut.
4. Close sliding part.
5. Hammer in wedge tightly. (Fig. A4.01c)
→ The Alignment Coupler is now securely in position.

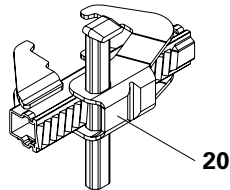


Fig. A4.01a

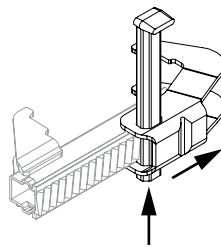


Fig. A4.01b

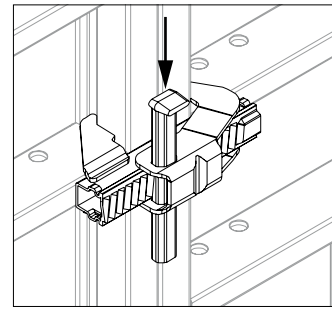


Fig. A4.01c



Is there a gap between the wedge head and the sliding part?
(Fig. A4.02a)



If the wedge head rests on the sliding part, there is no clamping effect.
(Fig. A4.02b)
If so: release wedge, re-position the sliding part and secure once again with the hammer.

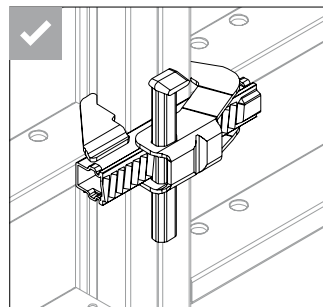


Fig. A4.02a

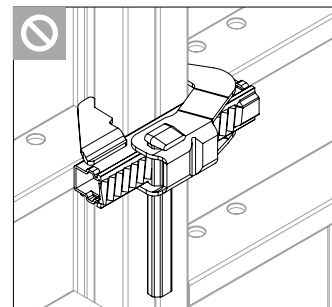


Fig. A4.02b



When securing the wedge, the following effects occur due to the angle of the frame profile:

1. Panels are flush.
 2. Panels are aligned.
 3. Panels are tightly connected.
- (Fig. A4.03)

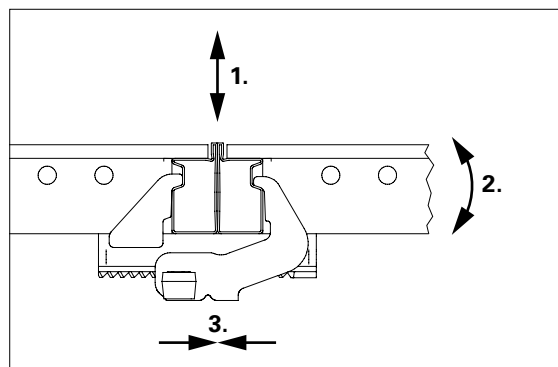


Fig. A4.03

Number of Alignment Couplers

The following table contains the number of Alignment Couplers required and refers to the respective sections where more information can be found.

Height	BFD standard joint	MXI H x 50/20	MXI H x 60	Length compensation	Stopec formwork	Height extensions
		see relevant section				
270 cm	2 pieces	B1 + B4	B2 + B5	B9	B10	B11
330 cm	3 pieces	C1 + C4	C2 + C5	C9	C10	C11

Arrangement of the Alignment Couplers

Height 270 cm (Fig. A4.04a)

Height 330 cm (Fig. A4.04b)

① = panel strut number
(Numbers progressively counted from bottom to top)

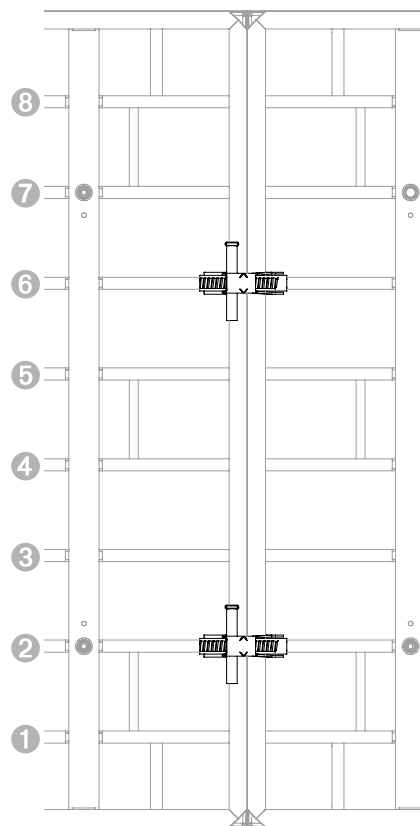


Fig. A4.04a

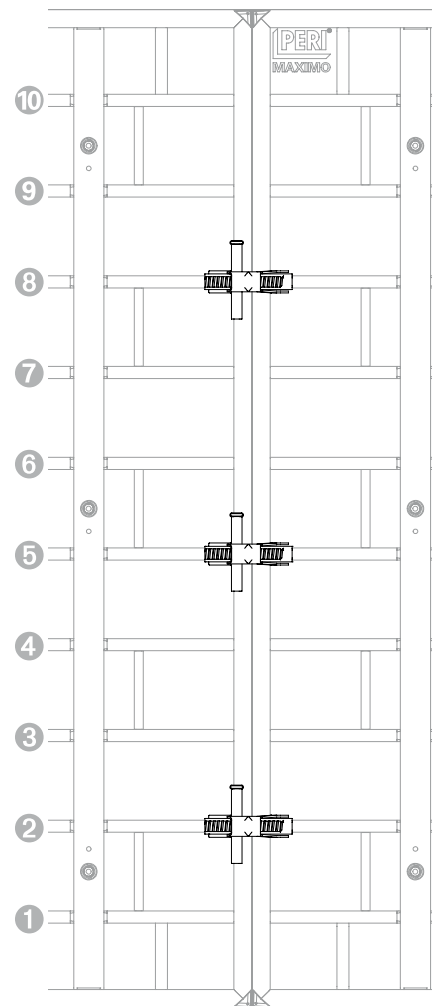


Fig. A4.04b

Compensation Walers MAR 85-3 and MAR 170-3

(Fig. A4.05)

The Compensation Walers MAR have a triple function as a panel connection: bracing, aligning, and transferring forces.

Pos.	Components	Item no.
21	Compensation Waler MAR 85-3	124941
22	Compensation Waler MAR 170-3	124942

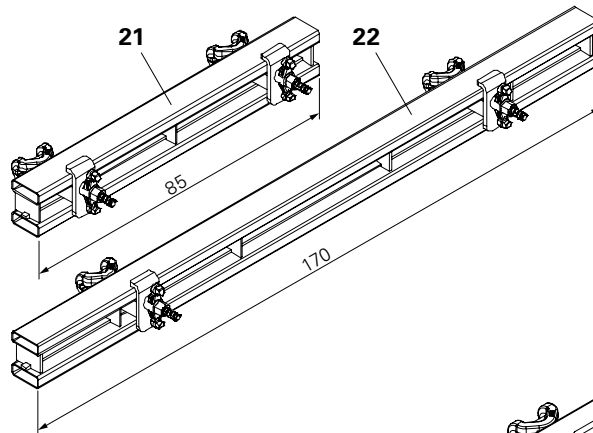


Fig. A4.05

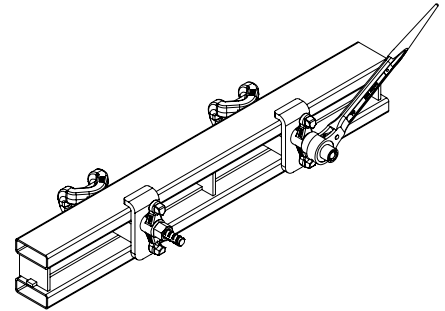


Fig. A4.05a

Areas of use:

- Longitudinal compensation, see Section B9.
- Corners with double Wall Thickness Compensator WDA.
- Extensions at great heights, see Section B11.
- Offset struts, see Fig. A4.06a.

Assembly

1. Insert double hooks into the connecting holes of the panel – 2x.
2. Tighten nut – 2x. (Fig. A4.06)



Nuts can also be tightened using the Ratchet MX 15. (Fig. A4.05a)



With T-junctions on straight walls, install Compensation Waler MAR 170 (22) centrally to the outgoing wall. Attach the double hook of the Compensation Waler to the middle holes. (Fig. A4.07)

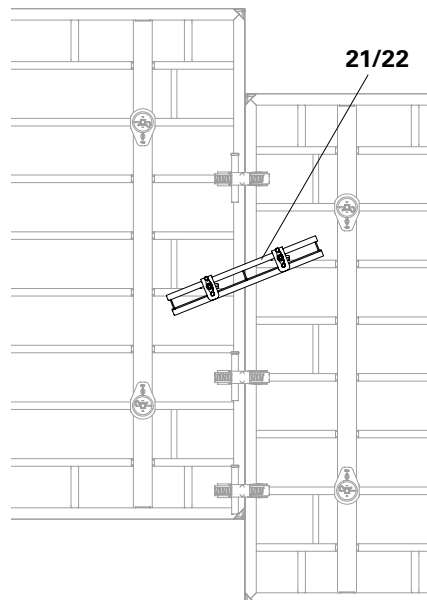


Fig. A4.06a

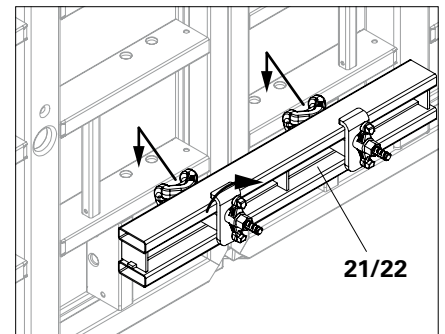


Fig. A4.06

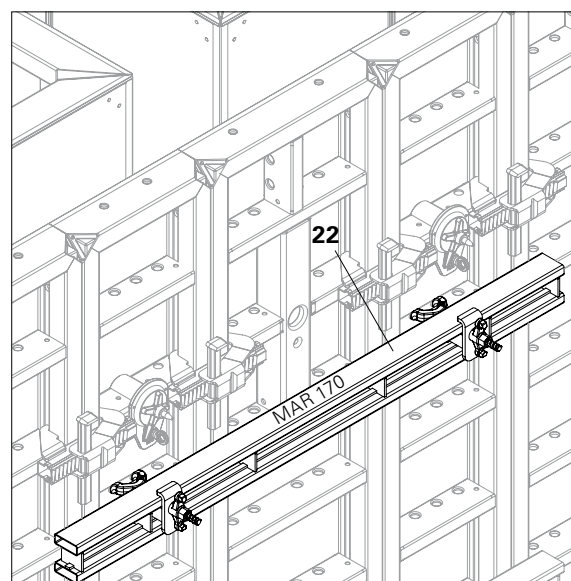


Fig. A4.07

Tie System MX 15

Perm. tensile force of the tie rods:
100 kN.

Tie MX 15, 15 -25

Item no. 113847

Ties for wall thicknesses of 15, 17.5, 20, 22, 24 and 25 cm (30).

(Fig. A5.01)

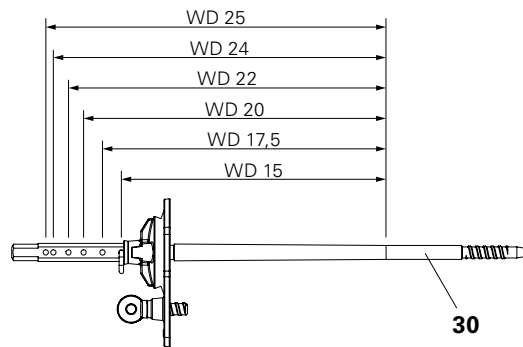


Fig. A5.01

Tie MX 15, 20 – 30

Item no. 112387

Ties for wall thicknesses of 20, 22, 24, 25 and 30 cm (31).

(Fig. A5.02)

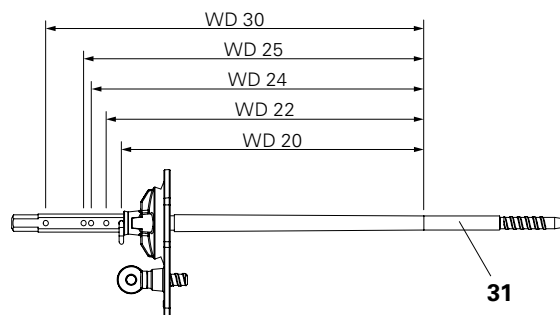


Fig. A5.02

Tie MX 15, 30 – 40

Item no. 112464

Ties for wall thicknesses of 30, 35, 36 and 40 cm (32).

(Fig. A5.03)

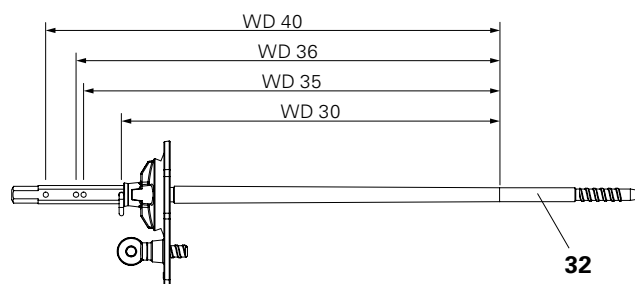


Fig. A5.03

Mount ties

Pos.	Components	Item no.
9	Ratchet MX 15	130798
10	Panel MX Height x width according to size	
10.1	Tie point	
30	Tie MX 15 according to wall thickness*	
30.1	Cotter Pin	
30.2	Nut	
30.3	Ring Bolt	
35	Swivel Nut MX 15	112386
35.1	Sleeve	
35.2	Ring Bolt	
40	Tie Rod Spanner MX 15	116841
57	Scaffold Ratchet	796061

* Size of tie is determined by the wall thickness.

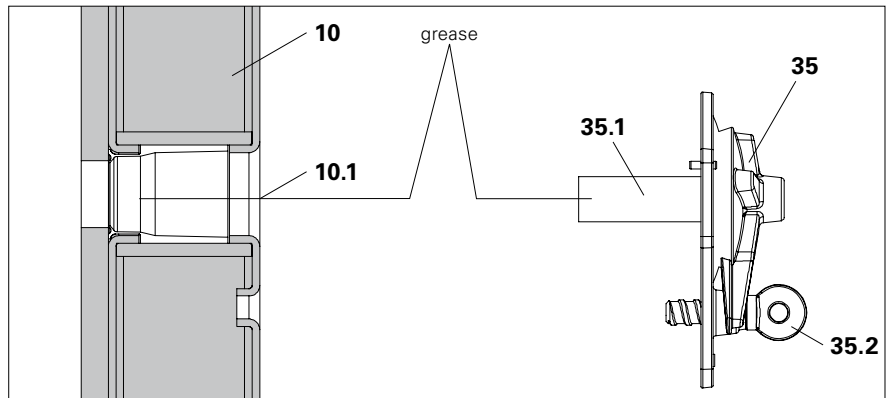


Fig. A5.04a



Fig. A5.04b

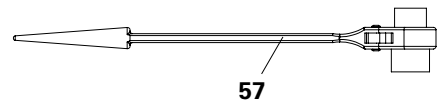


Fig. A5.04c



Fig. A5.04d

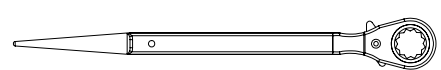


Fig. A5.04e



- Only use a Ratchet MX 15 (9), Tie Rod Spanner MX 15 (40) or Scaffold Ratchet (57).
- Do not attach any extensions as this can damage the ties.
- Do not use any ties which have been damaged.

Preparing the primary formwork for initial use

1. Grease tie point (10.1) in the panel (10) and sleeve (35.1) of the Swivel Nut MX 18 (35). (Fig. A5.04a)
2. Fix Swivel Nut MX 15 to the primary formwork by means of the Ring Bolt (35.2). Use Ratchet MX 15 (9), Tie Rod Spanner MX 15 (40) or Scaffold Ratchet (57). (Fig. A5.04d and Fig. A5.04e)

Prepare ties

1. Mark out wall thickness with Cotter Pin (30.1).
2. Turn Nut (30.2) to the Cotter Pin. (Fig. A5.05)
3. Grease Tie MX 15 (30), e.g. using PERI Bio Clean concrete release agent.

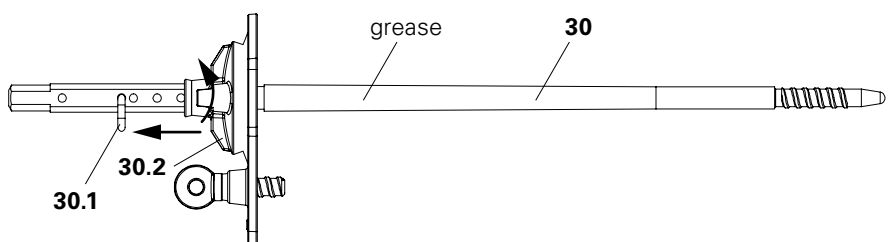


Fig. A5.05

Closing formwork

Important: pay attention to the order!

1. Push Tie MX 15 (30) through the tie hole of the formwork and screw into the Swivel Nut MX 15 (35).
2. Turn base plate with the Ring Bolt so that it can be fixed in position.
3. Screw in Tie MX 15 with the Ratchet MX 15 (9) or Tie Rod Spanner MX 15 as far as possible.
→ Nut (30.2) is lying flush on the formwork.
4. Slightly tighten the Ring Bolt (30.3) by means of the Ratchet MX 15 (9), Tie Rod Spanner MX 15 or Scaffold Ratchet (57). (Fig. A5.06 and A5.07a)

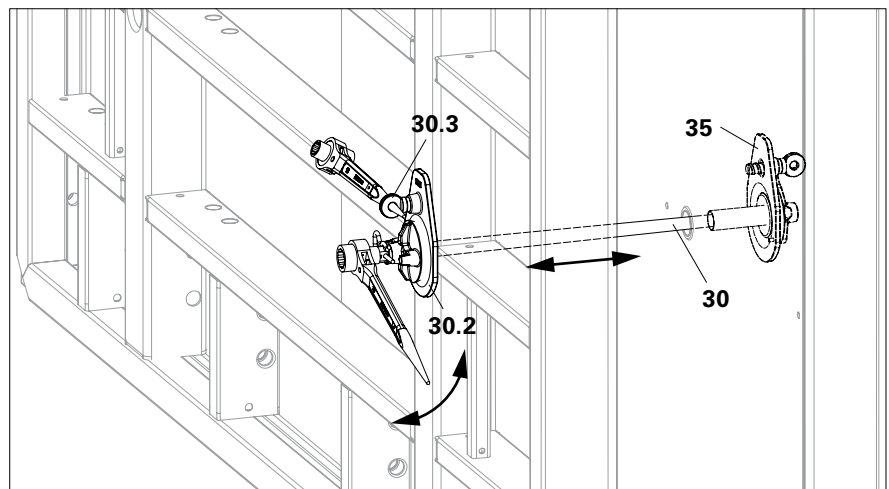


Fig. A5.06

Release ties



Warning

Risk of injury!

⇒ Before moving each time, tighten Swivel Nut MX 15 with the Ring Bolt.



- Release Ring Bolt (30.3) only using the Ratchet MX 15 (9), Tie Rod Spanner MX 15 (40) or Scaffold Ratchet (57).
- Screw out Tie (30) only using the Ratchet MX 15 (9) or Tie Rod Spanner MX 15 (40).

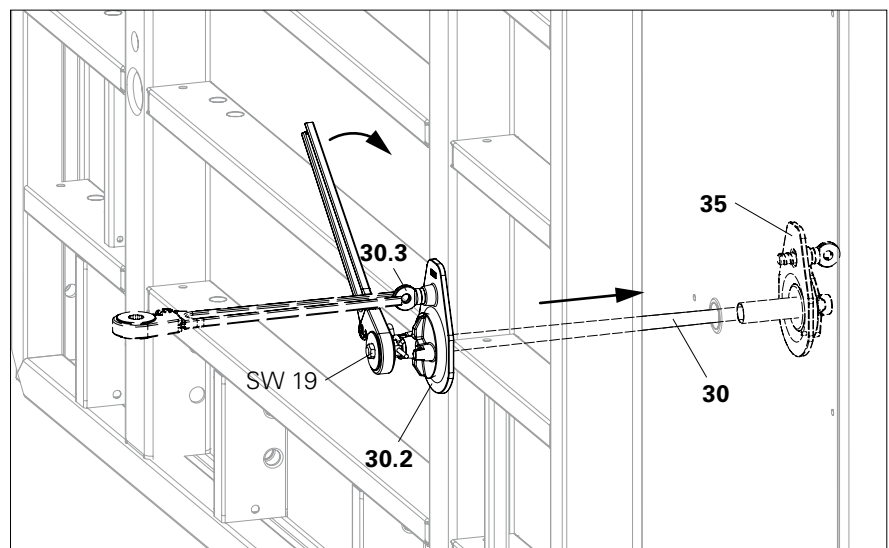


Fig. A5.07a

Important: pay attention to the order!

1. Release Ring Bolt (30.3) using the Tie Rod Spanner (40) or Scaffold Ratchet (57).
2. Screw out Tie MX 15 (30) with the Ratchet MX 15 (9) or Tie Rod Spanner MX 15 (40).
(Fig. A5.06 and A5.07b)

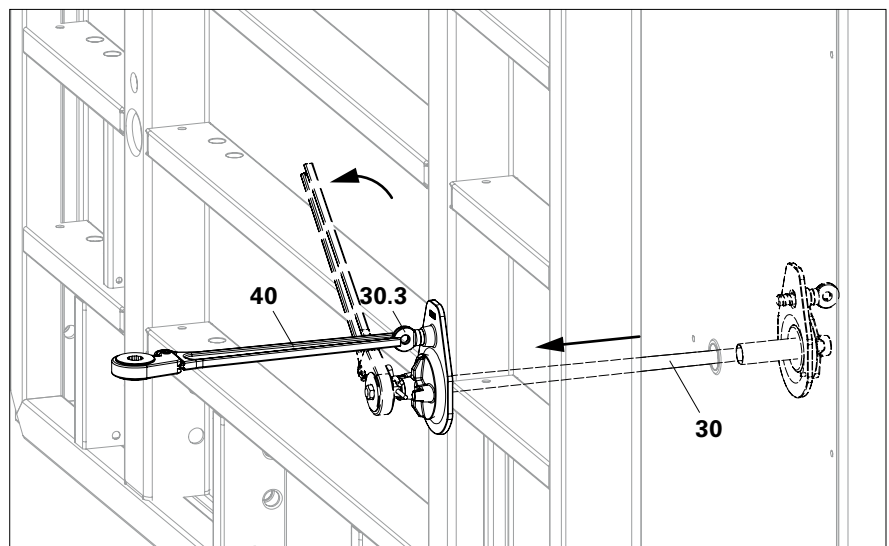


Fig. A5.07b

Closures

Pos.	Components	Item no.
74	Plug MXM 15, Ø 18.3 mm	124895
77	Plug MX 15, Ø 17.5 – 22 mm	114300

Plug MXM 15, Ø 18.3 mm

For closing tie holes in the formlining, e.g. Multi Panel MXM height x 60, Inside Corner MXI height x 50/20. (Fig. A5.08)



Fig. A5.08

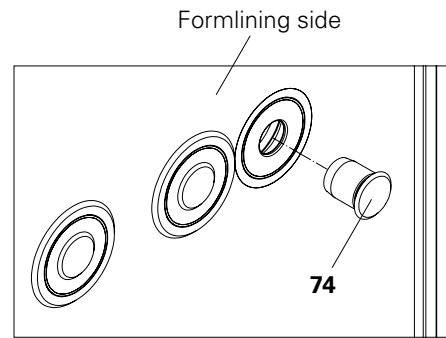


Fig. A5.08a

Shown:

Inside Corner MXI height x 50/20 (Fig. A5.08a)

Plug MX 15, Ø 17.5 – 22 mm

Visually-attractive closure of the tie point in the concrete. (Fig. A5.09)

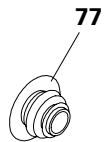


Fig. A5.09

Tie System DW 15

Single-sided tie operations

As an alternative to the Tie System MX 15, there are three versions available in order to anchor on one side with the Tie System DW 15.

- Version 1 with Cone MX DR 22/2 (Fig. A5.10)
- Version 2 with DK Sealing Cone DW 15/55 (Fig. A5.11)
- Version 3 with SK Anchor Cone DW 15/2 (Fig. A5.12)

Permissible load of the tie rod according to DIN 18216: 100 kN.



For one tie point with SK Anchor Cone DW 15/2, three tie rods are required – 2x external and 1x internal (length according to wall thickness).

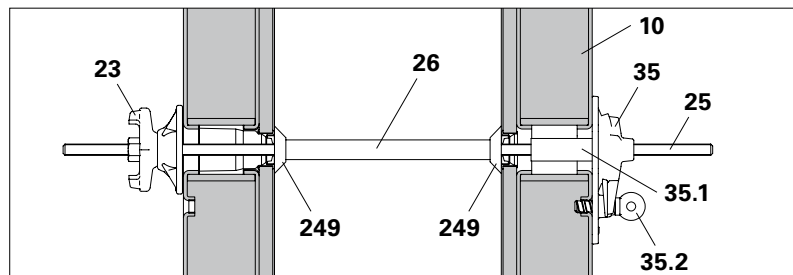


Fig. A5.10

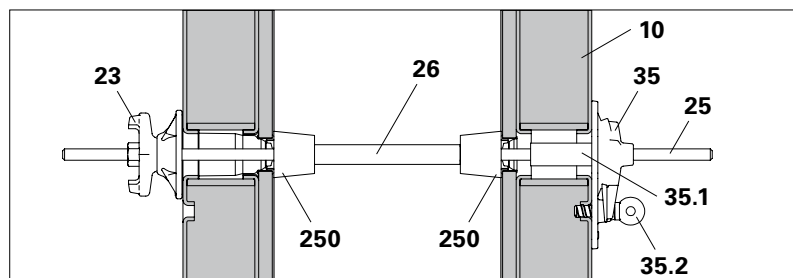


Fig. A5.11

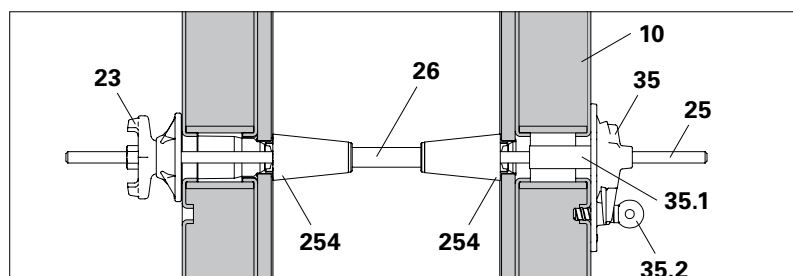


Fig. A5.12

Pos.	Components	Qty.
23	Wingnut Pivot Plate DW 15	1x
25	Tie Rod DW 15*	1x
26	Spacer Tube Rough 22*	1x
35	Swivel Nut MX 15	1x
35.1	Sleeve of Swivel Nut	
35.2	Ring Bolt	
	Version 1	
249	Cone MX DR 22/2	2x
	Version 2	
250	DK Sealing Cone DW 15/55	2x
	Version 3	
254	SK Anchor Cone DW 15/2	2x

* according to wall thickness

Assembly

1. Assemble the primary formwork
 - Grease tie points in the panel (10) and sleeve of the Swivel Nut MX 15 (35). (Fig. A5.04a)
 - Fix Swivel Nut MX 15 (35) to the primary formwork by means of the Ring Bolt (35.2). Use Tie Rod Spanner MX 15 or Scaffold Ratchet.
 - Erect panel and position at place of use.
 - Support panel and secure.
 - Install reinforcement.
2. Prepare ties

Mark projection on one side of the tie rod (25). Projection = 200 mm.
3. Mount tie rod
 - From the inside, push tie rod through the reinforcement and tie point of the panel.
 - Screw tie rod (25) into the Swivel Nut MX 15 (35) up to the marking.
 - Attach cone (249 / 250 / 251).
 - Attach tube (26).
 - Attach cone (249 / 250 / 251).
 - Secure components in the reinforcement using tie wire.
4. Mount the closing formwork
 - Position closing formwork.
 - Screw on Wingnut Pivot Plate (23) and tighten tie point.

Two-sided anchoring

Permissible load of the tie rod according to DIN 18216: 100 kN.

Pos.	Components	Qty.
23	Wingnut Pivot Plate DW 15	2x
25	Tie Rod DW 15	1x
26	Tube Rough 22	1x
249	Cone MX DR 22/2	2x

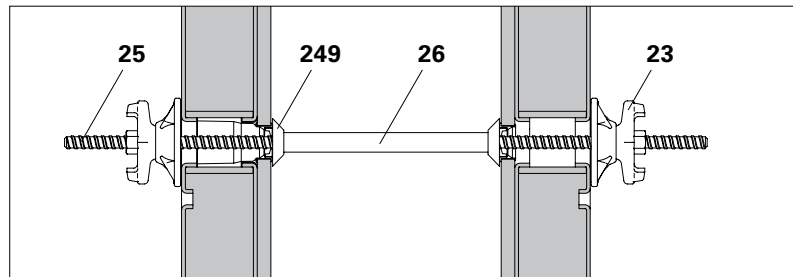


Fig. A5.13

(Fig. A5.13)

Tool

Pos.	Component	Item no.
98	Tie Rod Wrench 15	031070

Tie Rod Wrench 15 (98) for tie point operations – requiring only one site worker positioned on one side of the formwork.

(Fig. A5.14)

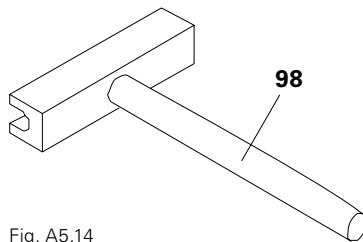


Fig. A5.14

Closures

Plug MX Ø 17.5 – 22 mm

Item no. 114300

Visually-attractive closure of the tie point in the concrete. (Fig. A5.15)

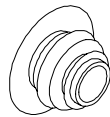


Fig. A5.15

Cone MX DR 22/2

Item no. 125299

Sealing the Spacer Tube DR 22 or FZR 22.

The cone covers the MAXIMO sealing. (Fig. A5.16)

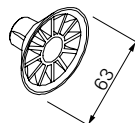


Fig. A5.16

DK Sealing Cone DW 15/55

Item no. 031636

Sealing the Spacer Tube DR 22 or FZR 22. (Fig. A5.17)

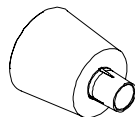


Fig. A5.17

Tie System DW 20

Two-sided anchoring

For high formwork pressure.
Permissible load of the tie rod according to DIN 18216: 150 kN.

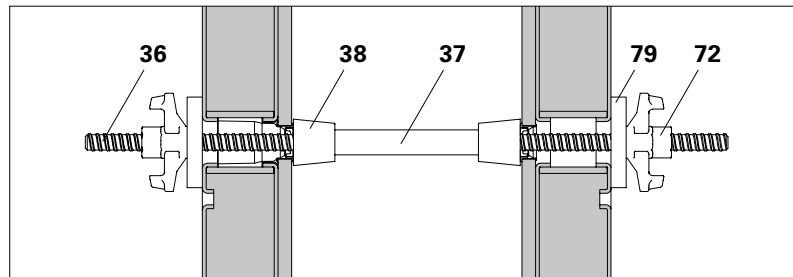


Fig. A5.18

Pos.	Components	Qty.
36	Tie Rod DW 20	1x
37	Spacer Tube Rough 28	1x
38	DK Sealing Cone DW 20/55	2x
72	Wingnut DW 20	2x
79	Counterplate DW 20	2x

(Fig. A5.18)

Tool

Pos.	Component	Item no.
99	Tie Rod Wrench 20	031050

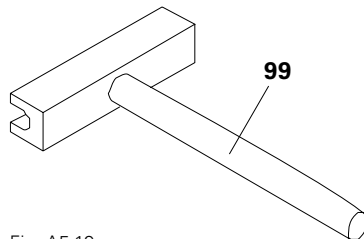


Fig. A5.19

Tie Rod Wrench 20 (99) for tie point operations – requiring only one site worker positioned on one side of the formwork.
(Fig. A5.19)

Inclined ties



- The conical tie hole allows inclined anchoring of up to 4° on all sides. (Fig. A5.20 + A5.24)
- Inclined anchoring is possible with both vertically and horizontally-positioned panels.
- Secure panels against lifting!

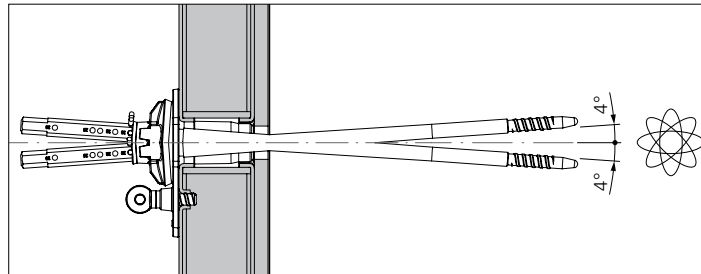


Fig. A5.20

For Tie MX 15 and Tie Rod DW 20, there are other areas of application:

Tie MX 15

Inclined on one side: max. 4°.
(Fig. A5.21)

Inclined on both sides: max. 2x 4°.
(Fig. A5.22)

Height offset: max. 1 cm per 10 cm
wall thickness.
(Fig. A5.23)

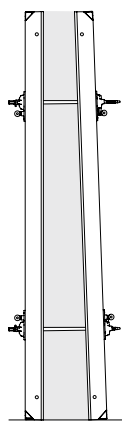


Fig. A5.21

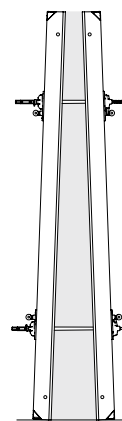


Fig. A5.22

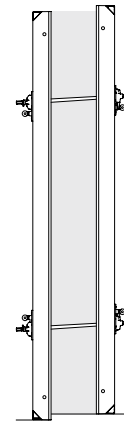


Fig. A5.23

Tie Rod DW 20

Inclined on one side: max. 4°.
(Fig. A5.25)

Inclined on both sides: max. 2x 4°.
(Fig. A5.26)

Height offset: max. 1 cm per 10 cm
wall thickness.
(Fig. A5.27)

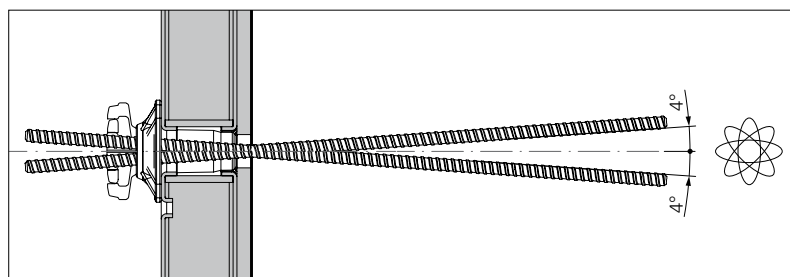


Fig. A5.24

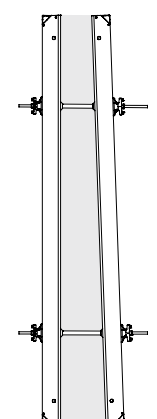


Fig. A5.25

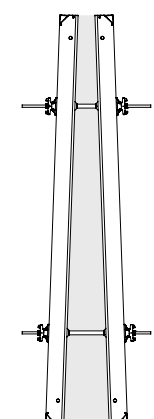


Fig. A5.26

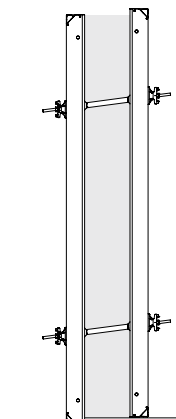


Fig. A5.27

Closing tie points

Sealing against pressing water and non-pressing water for waterproof tie points as well as fire and soundproof tie points.



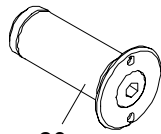
- Installation is only required on the pressing water side.
- Stoppers are not suitable for use in aggressive water or similar, e.g. sewage treatment plants!

There are four types of plugs:

1. Stopper MX 15-50 MF LS (90) (Fig. A5.28a)
2. Stopper MX 15-75 MF-S (92) Stopper MX 15-75 MF-L (93) (Fig. A5.28b)
3. Stopper MX 15-50 OF LS (91) (Fig. A5.28c)
4. Stopper MX 15-75 OF-S (94) Stopper MX 15-75 OF-L (95) (Fig. A5.28d)

* = waterproof

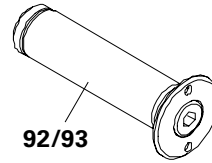
MX 15-50 MF LS



90

Fig. A5.28a

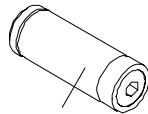
MX 15-75 MF-S
MX 15-75 MF-L



92/93

Fig. A5.28b

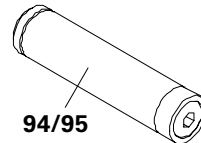
MX 15-50 OF LS



91

Fig. A5.28c

MX 15-75 OF-S
MX 15-75 OF-L



94/95

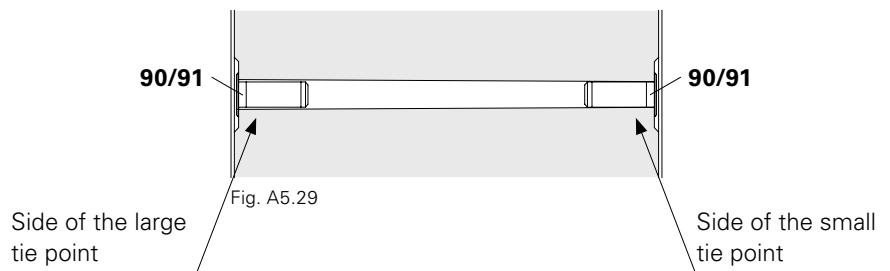
Fig. A5.28d

Possible uses of the Stopper MX 15 for tie points with special requirements

Pos.	Stopper	Item no.	Sealing against water	Fire-resistance	Soundproofing
90	MX 15-50 MF LS	127064	Sealing against non-pressing water. Stopper fitted on the water side.	Walls with Fire Resistance F90. Test report available. Stoppers on both sides.	Walls with sound protection function. Test report available. Stoppers on one side or both sides.
91	MX 15-50 OF LS	127065	Sealing against non-pressing water. Stopper fitted on the water side.	Walls with Fire Resistance F90. Test report available. Stoppers on both sides.	Walls with sound protection function. Test report available. Stoppers on one side or both sides.
92 93	MX 15-75 MF-S MX 15-75 MF-L	126991 126988	For waterproof components Test report available. Stoppers on one side – water side.	Walls with Fire Resistance F90. Test report available. Stoppers on both sides.	Walls with sound protection function. Test report available. Stoppers on one side or both sides.
94 95	MX 15-75 OF-S MX 15-75 OF-L	126997 126995	For waterproof components Test report available. Stoppers on one side – water side.	Walls with Fire Resistance F90. Test report available. Stoppers on both sides.	Walls with sound protection function. Test report available. Stoppers on one side or both sides.

Stopper MX 15-50

Stopper MX 15-50 MF LS (90) or MX 15-50 OF LS (91) can be installed in both small and large tie point diameters. (Fig. A5.29)



Stopper MX 15-75

Always install Stopper MX 15-75 MF-S (black) (92/94) in tie holes with small diameters, and Stopper MX 15-75 MF-L (grey) (93/95) in tie holes with large diameters. (Fig. A5.30)

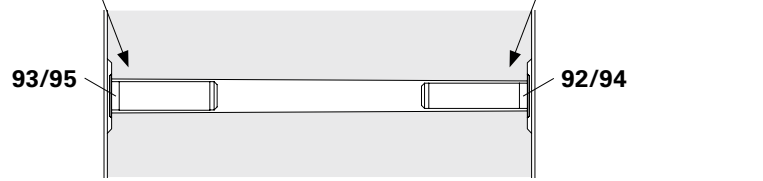
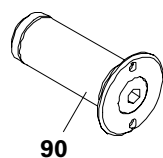


Fig. A5.30

Assembly of Stoppers with flange

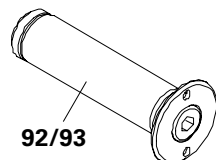
1. If necessary, pre-tension Stopper (90/92/93) with 5 mm Allen key.
2. Insert Stopper into the tie opening up to the level of the flange.
3. Attach Stud Spanner MX 15.
4. Tension the Stopper with 10 Nm. (Fig. A5.31)

MX 15-50 MF LS (black)



90

MX 15-75 MF-S (black)
MX 15-75 MF-L (grey)



92/93

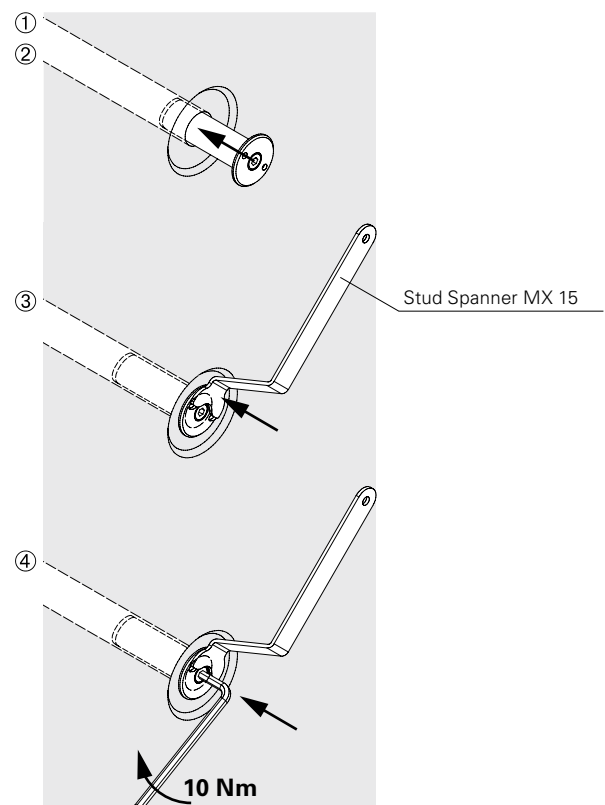
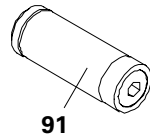


Fig. A5.31

Assembly of Stoppers without flange

1. Pre-tension Stopper (91/94/95) with 5 mm Allen key in order that it can be pushed into the tie opening.
2. Insert Stopper with Allen key up to length of stopper.
3. When tensioning, make sure the Allen key is at an angle.
→ This prevents overtightening of the Stopper.
4. Tension the Stopper with 10 Nm.
(Fig. A5.32)

MX 15-50 OF LS (black)



MX 15-75 OF-S (black)
MX 15-75 OF-L (grey)

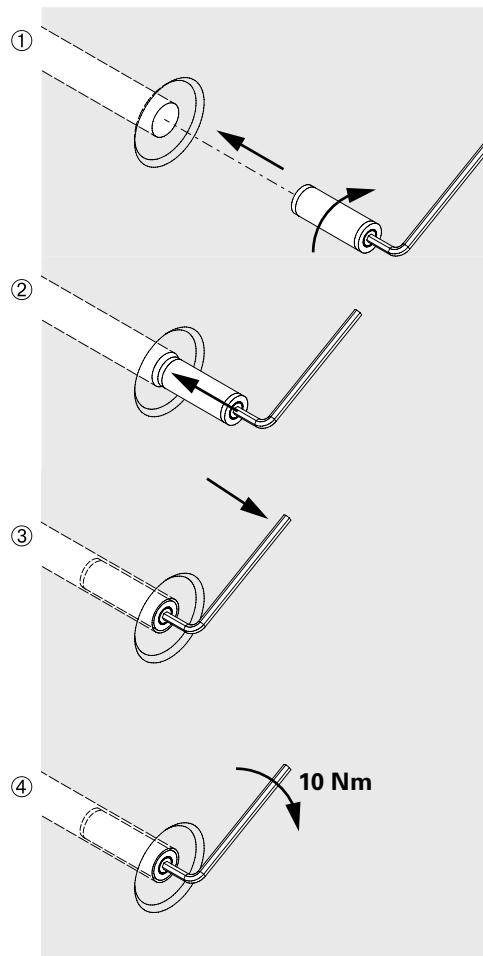
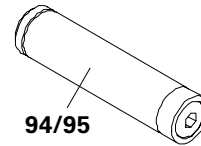


Fig. A5.32

Brace Connector



The Brace Connector is the connection between Push-Pull Prop or Kicker and Panel MX. (Fig. A6.01)

Push-Pull Props and Kickers are attached to the panel with the Brace Connector (45). The connection is possible on:

- horizontal panel struts
- vertical panel struts

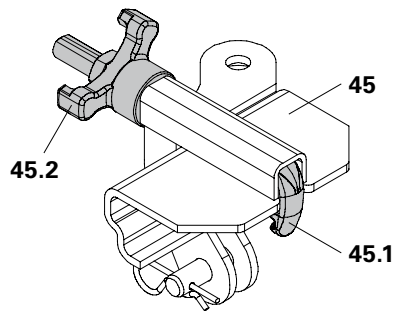


Fig. A6.01

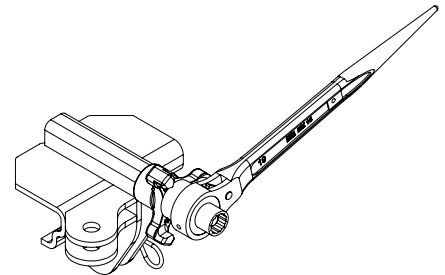


Fig. A6.01a

Pos.	Components	Item no.
45	Brace Connector TRIO	023660
45.1	Hook Tie	
45.2	Triple Wingnut	

Assembly

1. Attach the Brace Connector (45) to the panel strut so that the Hook Tie (45.1) is securely fixed in a connecting hole.
2. Tighten Brace Connector by means of a Triple Wingnut (45.2).

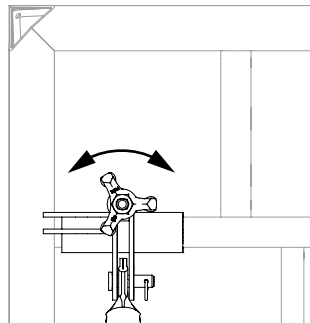


Fig. A6.02

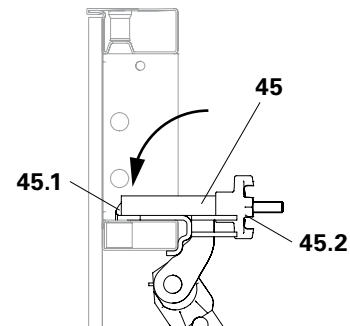


Fig. A6.02a

Connecting to horizontal panel struts

(Fig. A6.02 + A6.02a)

Connecting to vertical panel struts

(Fig. A6.03 + A6.03a)



For assembly, the Ratchet MX 15 can be used. (Fig. A6.01a)

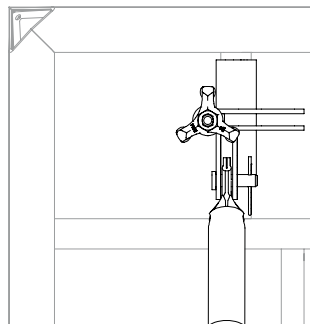


Fig. A6.03

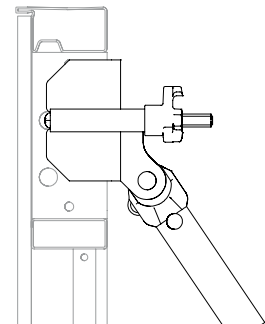


Fig. A6.03a

Base Plate RS

Pos.	Component	Item no.
41	Push-Pull Prop RS	according to size
47	Base Plate-3 for RS 210 – 1400	126666

Assembly

1. Fix the bottom part of the Push-Pull Prop (41a) – here as Kicker – with Bolts (47.1) and Cotter Pins (47.2) to the back of the Base Plate (47).
 2. Fix the bottom part of another Push-Pull Prop (41b) – here as Push-Pull Prop – with Bolts (47.3) and Cotter Pins (47.2) to the Base Plate (47).
- (Fig. A6.04)

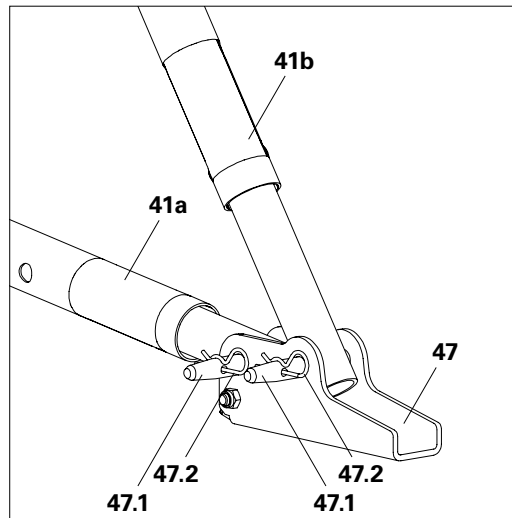


Fig. A6.04

Push-Pull Props and Kickers



- Follow Instructions for Assembly and Use for RS and RSS Push-Pull Props
 - When using PERI Anchor Bolt 14/20x130, take into account the Technical Data Sheet.
 - Number of Push-Pull Props
 - on the first panel: 2 Push-Pull Props
 - second and subsequent panels: 1 Push-Pull Prop
- (Fig. A6.05 + A6.06)

Pos.	Components	Item no.
8	PERI Anchor Bolt 14/20x130	124777
41a	Push-Pull Prop RS according to size	
41b	Push-Pull Prop RS (as Kicker) according to size	
45	Brace Connector	023660
47	Base Plate-3 for RS 210 – 1400	126666

Assembly on Brace Connector

1. Fix Push-Pull Prop (41a) and Kicker (41b) to the connection lugs of the Brace Connector by means of bolts and cotter pins.
- (Fig. A6.05 + A6.05a)

„A-A“

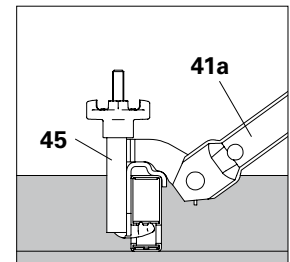


Fig. A6.05a

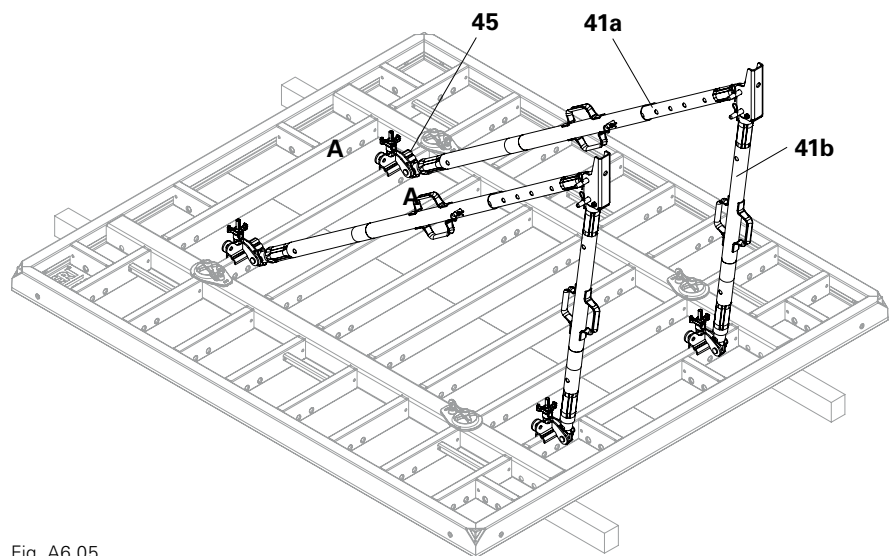


Fig. A6.05

Assembly of the Base Plate

1. Mount Base Plate (47) on a flat and sufficiently load-bearing surface area, e.g. using PERI Anchor Bolt 14/20x130 (8). (Fig. A6.06a)

→ Push-Pull Prop has now been securely fixed in position.

(Fig. A6.06 – concreting platform not shown)



- If it is not possible to assemble or adjust the Kicker on the lowest panel strut, the connection can also be made up to the height of the second strut.
- Instead of Push-Pull Props RS, the Push-Pull Props RSS and Kickers AV can also be used.

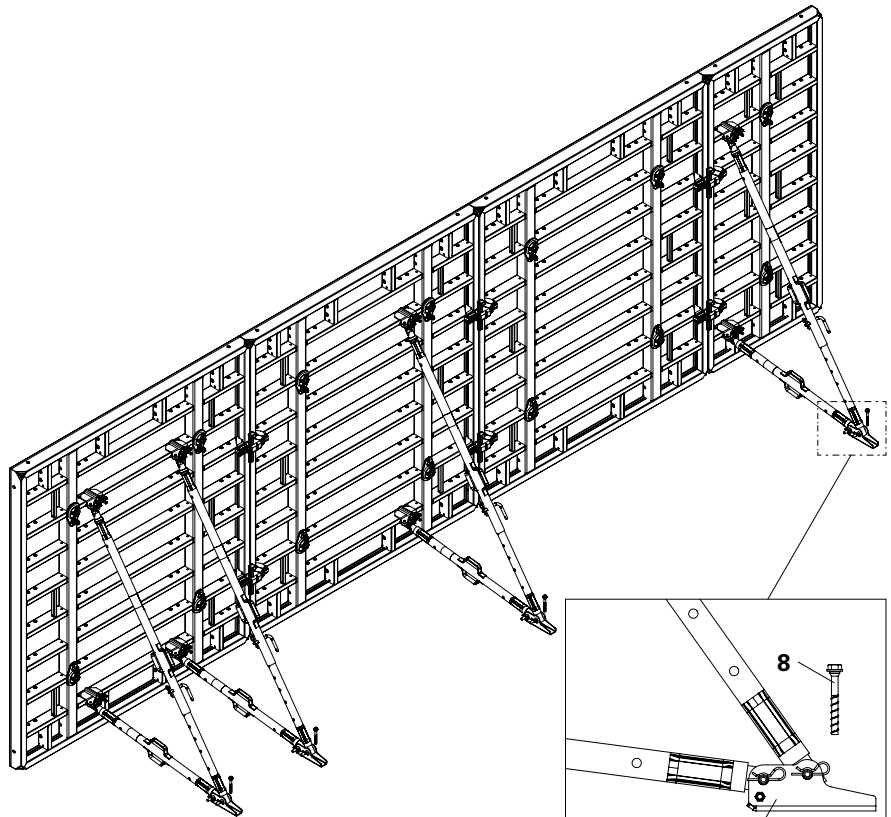


Fig. A6.06

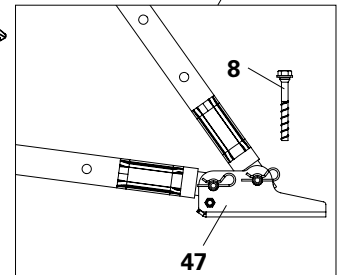


Fig. A6.06a

Standard application

		Formwork height h [m] System 1						Formwork height h [m] System 2			
		3.00	4.00	5.00	6.00	7.00	8.00	9.00	10.00	11.00	12.00
Perm. width of influence [m]	EB_{ref}	5.20	4.04	2.74	2.26	2.05	1.74	2.45	2.04	1.80	1.50
Actual Push-Pull Prop load [kN]	F_{RS1}	11.5	11.5	11.5	11.5	11.5	11.5	11.5	11.0	11.5	11.5
	F_{RS2}							10.9	11.5	11.2	10.5
Actual Kicker load [kN]	F_{AV}	2.7	2.9	2.8	2.7	3.2	3.5	4.2	3.6	3.4	3.1
Base Plate Resulting force [kN]	①	13.7	13.7	13.5	13.4	13.7	13.9	11.5	11.0	11.5	11.5
	②							14.2	14.3	13.7	12.8
Resulting angle of attack [°]	①	52.4	51.1	51.1	51.1	49.4	48.2	60.0	60.0	60.0	60.0
	②							47.9	49.8	49.9	49.8
Lifting force V _{Wind} [kN/m]		2.1	2.6	3.8	4.6	5.1	5.9	8.4	10.0	11.4	13.2
x = Distance of Base Plate from rear edge of formwork [m]	x₁	1.2	1.6	2.0	2.4	3.0	3.6	4.2	4.7	5.1	5.5
	x₂							2.6	2.6	2.8	3.0
y = Top connection point from top edge of formwork [m]	y₁	1.0	1.2	1.5	1.8	1.8	1.8	1.5	1.8	2.1	2.4
	y₂							4.5	5.5	6.2	6.9
q(z=h) = q _h [kN/m ²]		0.50	0.50	0.58	0.58	0.58	0.61	0.64	0.67	0.69	0.71

Assumptions:

- Wind loads according to DIN EN 1991-1-4 $w = q(z) \times c_p \times \kappa$ [kN/m²]
- Wind Zone 2, Terrain Category III
- Applied pressure coefficient $c_p = 1.8$ (see graphic, below)
- Formwork in vertical position on ground
- Service life factor $\kappa = 0.6$
- $q(z)$ = peak velocity pressure
- Inclination of the Push-Pull Props to the horizontal 60°
- Values are characteristic values

Note:

Anti-lift off protection is provided if the lifting force

$$F_{A,d} = 1.5 \times V_{Wind} - 0.9 \times G \times h > 0$$

G = surface area weight of the formwork including platforms.

In the end area LE, the following c_p values or wind loads are assumed:

$$L/h \leq 3: c_{p,End} = 2.3^*$$

$$L/h = 5: c_{p,End} = 2.9^*$$

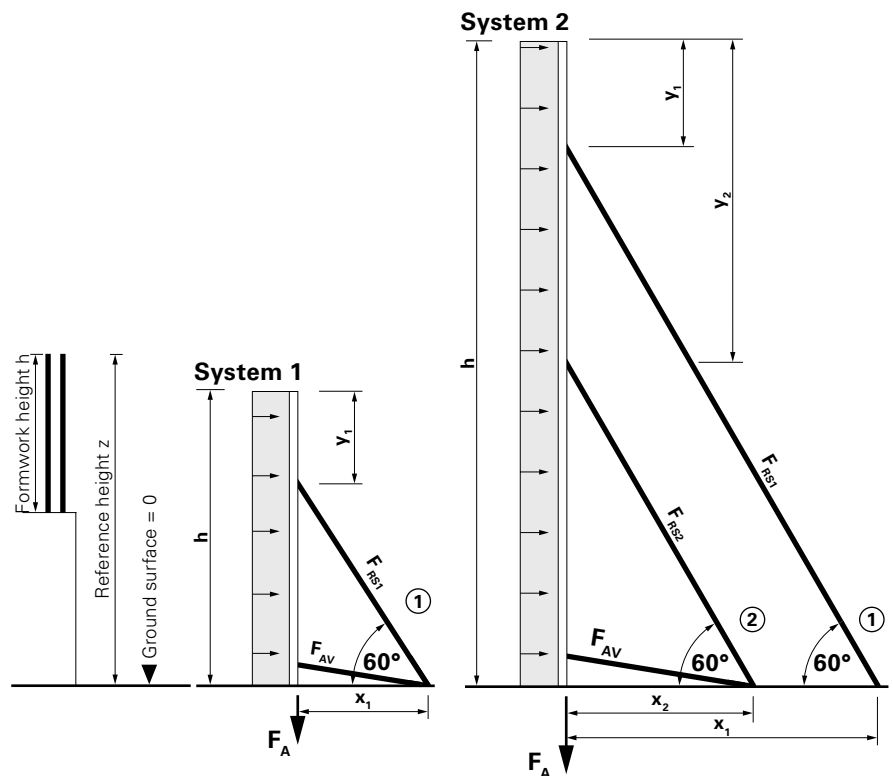
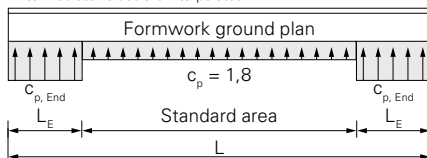
$$L/h \geq 10: c_{p,End} = 3.4^*$$

L_E = length of end area (0.3 x h)

h = formwork height

L = formwork length

*intermediate values are interpolated





- The following systems are described:
 - Bracket System – MAXIMO MXK
 - Scaffold Bracket TRIO
 - Concreting Platform MX
 - Concreting Platform TRIO
 - Handrail Post Holder MX
 - Guardrails with boards
- Working platforms are mounted as part of the pre-assembly process.

Bracket System – MAXIMO MXK

A concreting platform is installed on the formwork using the Scaffold Bracket MXK (60).

Technical data

- Perm. load: 150 kg/m² Load Class 2 according to DIN EN 12811-1



Warning

Risk of injury!

- ⇒ Secure planking.
- ⇒ Decking components and guardrails must be positioned so that any movement is prevented.
- ⇒ Follow Instructions for Assembly and Use for the MAXIMO MXK Bracket System.



Assembly: see Instructions for Assembly and Use for the MAXIMO MXK Bracket System.

Pos.	Components	Item no.
60	Scaffold Bracket MXK	126356
61	Guardrail Post MXK	126360

Shown: height 2.70 m
(Fig. A7.01)

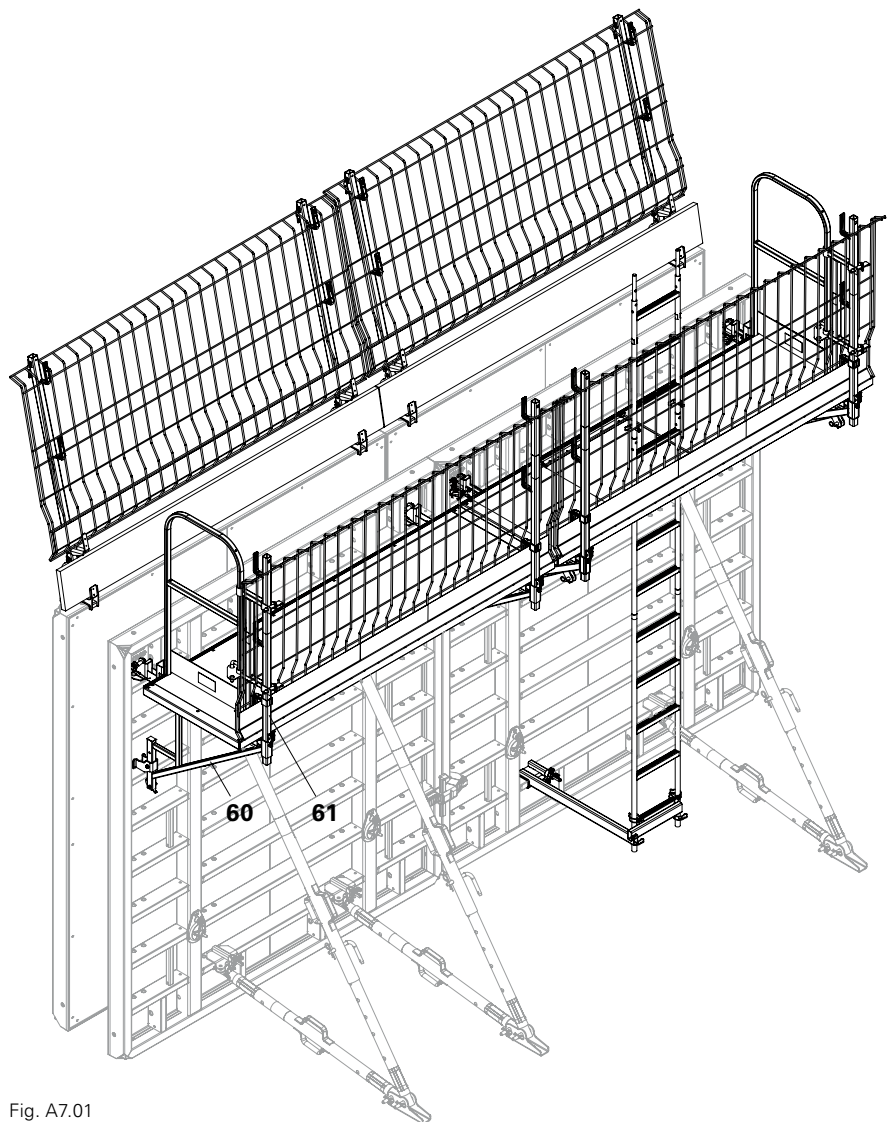


Fig. A7.01

Scaffold Bracket TRG 80 or TRG 120

Technical data

- Perm. load: 150 kg/m² Load Class 2 according to DIN EN 12811-1
- Max. width of influence 1.35 m

A concreting scaffold is erected on the formwork by means of the Scaffold Brackets (88/264). (Fig. A7.02)

There are two connecting possibilities:

- Horizontal Locking Pins for holes in the vertical panel strut* (88.1).
- Vertical Locking Pins for holes in the horizontal panel strut* (88.2).

(Fig. A7.02a)

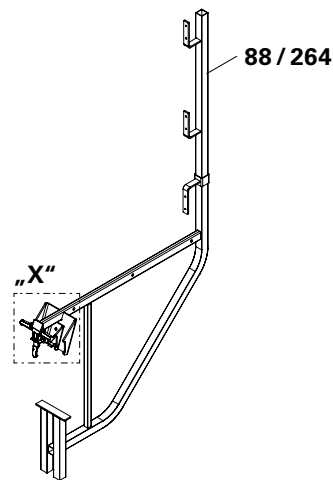


Fig. A7.02

Detail "X"

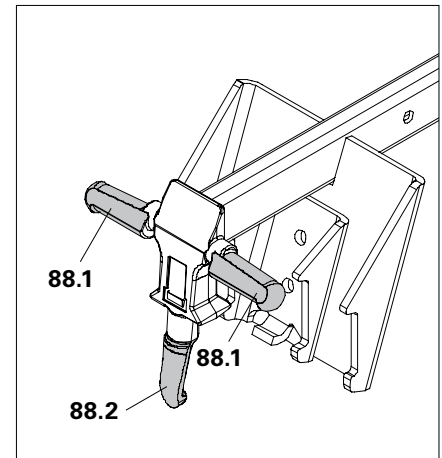


Fig. A7.02a



Warning

Risk of injury!

- ⇒ Always mount the Scaffold Bracket TRG from a safe working position, e.g. a mobile scaffold.
- ⇒ Secure planking.
- ⇒ Decking components and guardrails must be positioned so that any movement is prevented.



There are two possibilities available for suspending the Scaffold Bracket on the panel struts:

- Horizontal panel struts (Fig. A7.03)
- Vertical panel struts (Fig. A7.04)

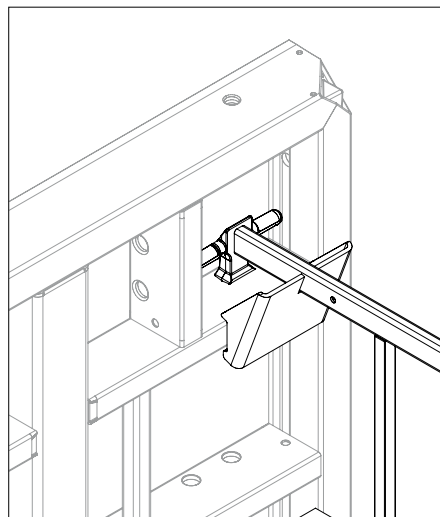


Fig. A7.03

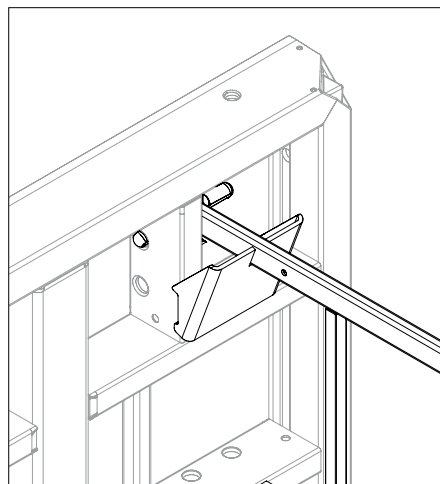


Fig. A7.04

Pos.	Components	Item no.
88	Scaffold Bracket TRG 80	023670
88.1	Horizontal Locking Pins for holes in the vertical* panel strut	
88.2	Vertical Locking Pins for holes in the horizontal* panel strut	
264	Scaffold Bracket TRG 120	023680
265	End Guardrail Frame 55	065066

* vertically-positioned panel

Assembly

1. Suspend Scaffold Bracket (88 / 264) on right using the connecting holes on the panel. (Fig. A7.05a + A7.05b)
2. Suspend Scaffold Bracket (88 / 264) on left using the connecting holes on the panel.



Horizontal panel strut or vertical panel strut:
Have all Locking Pins been completely inserted into the holes?

3. Install planking from below over the complete width of the brackets and secure in position.
4. Install guardrails and secure with nails.
5. Attach side protection, e.g. End Guardrail Frame 55 (265). (Fig. A7.06)

Shown:
Height 270 cm – without Push-Pull Props
(Fig. A7.05a + A7.05b and A7.06)



With extended formwork units, the working scaffolds are mounted on horizontally-positioned panels as part of the pre-assembly process.

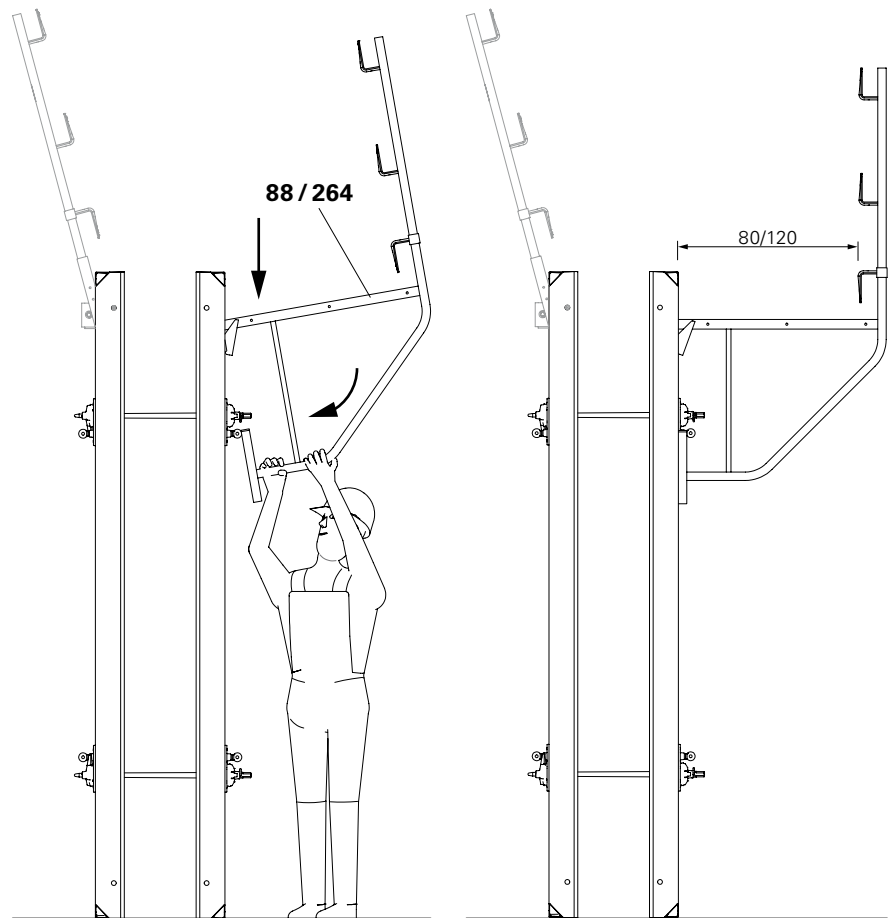


Fig. A7.05a

Fig. A7.05b

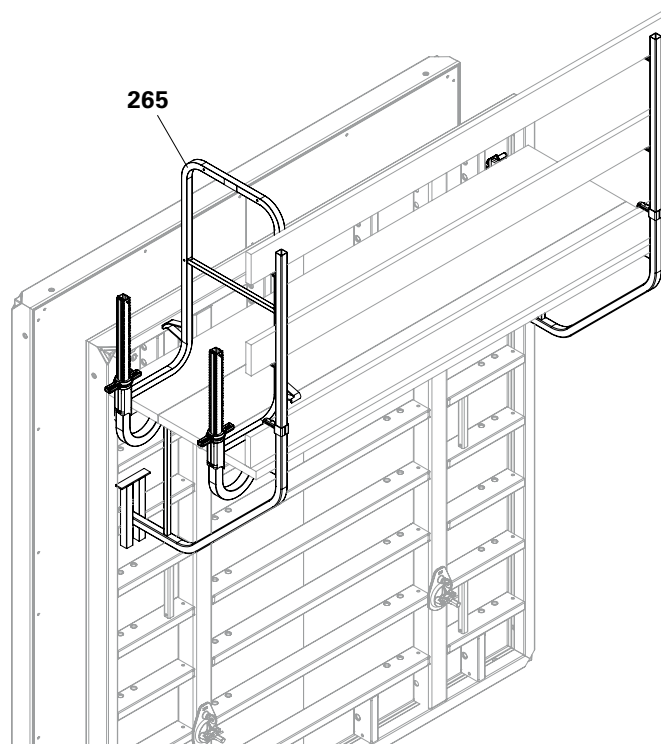


Fig. A7.06

Concreting Platform MX



Warning

- Risk of injury!
⇒ The Concreting Platform MX must be dismantled during temporary storage of the panel.
- Risk of falling!
⇒ If gaps arise between the individual concreting platforms, these are to be regarded as potential cause of falling! When closing gaps arising between the concreting platforms, use PPE at all times!

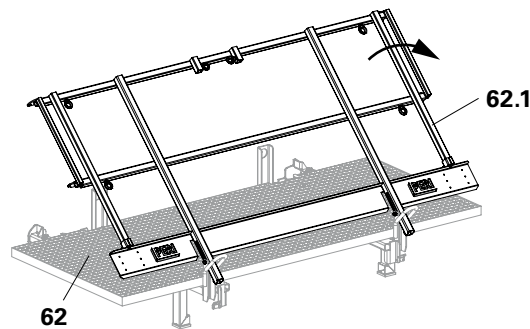


Fig. A7.07

Perm. load: 150 kg/m²

Load Class 2 according to DIN EN 12811-1.

Concreting Platform MX 100 x 240

Pos.	Components	Item no.
62	Concreting Platform MX 100 x 240	127273
62.1	Guardrail	
62.2	Suspension Beam	
62.3	Sliding Sleeve	
62.4	Ring Bolt	
62.5	Guardrail Extension	
62.6	Retaining Claw	
62.7	Lug	
69	End Guardrail MXP	
	right	115946
	left	115945
69.1	Bolts	

Preparing the Concreting Platform MX 100 x 240

1. Pull out guardrail (62.1) horizontally. (Fig. A7.07a)
2. Fold guardrail (62.1) upwards until the guardrail is at right-angles to the decking. (Fig. A7.07b + A7.07c)
3. Push guardrail (62.1) downwards. → Guardrail is now secured. (Fig. A7.07d)

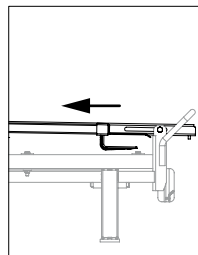


Fig. A7.07a

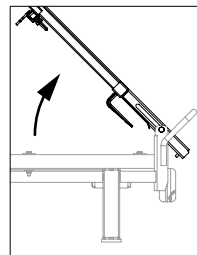


Fig. A7.07b

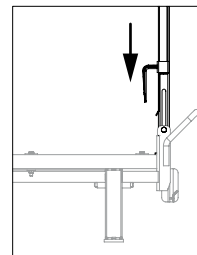


Fig. A7.07c

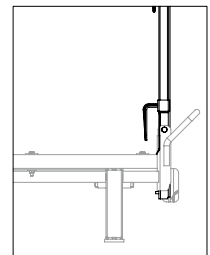


Fig. A7.07d

4. Fold up suspension beam (62.2).
Ensure that the sliding sleeve (62.3) is at the top.
(Fig. A7.08 + A7.08a + A7.08b)
5. Push the sliding sleeve (62.3) downwards.
→ The suspension beam is now engaged. (Fig. A7.08c + A7.08d)

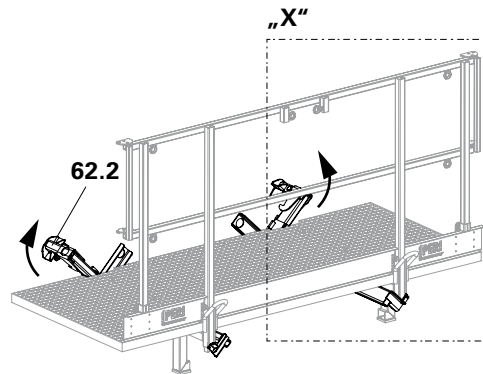


Fig. A7.08

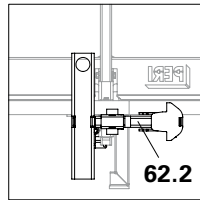


Fig. A7.08a

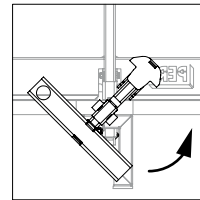


Fig. A7.08b

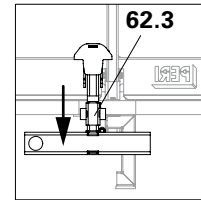


Fig. A7.08c

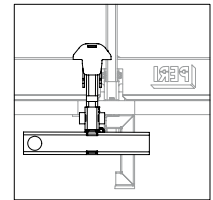


Fig. A7.08d



- In order to position the extension of the guardrail (62.5), pull out the extension sideways, turn it 90° and then insert into the sleeves on the top guardrail and secure with the ring bolt (62.4) – right and left is possible. (Fig. A7.08e)
- Gaps between the concreting platforms: max. 50 cm.
 - In order to close any gaps, pull out the guardrail extensions (62.5) sideways and secure using ring bolts (62.4). (not shown)
 - Fix Toeboard with nails.
 - Install scaffold boards and secure.

Detail "X"

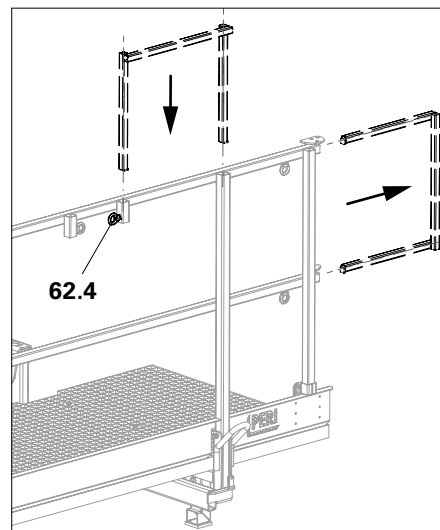


Fig. A7.08e

Guardrail installation



- Mount End Guardrail Frames (69) on all leading edges. (Fig. A7.09)
- Position guardrail extension of the concreting platform, see Fig. A7.08e.

Assembly

1. Pull bolt (69.1) upwards and hold. (Fig. A7.09a)
2. Install End Guardrail Frame. (Fig. A7.09)
3. Release bolt.
 - Bolt pivots back and engages thus securing the guardrail in position.



Is the bolt engaged? (Fig. A7.09b)

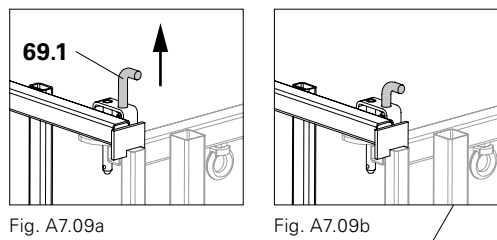


Fig. A7.09a

Fig. A7.09b

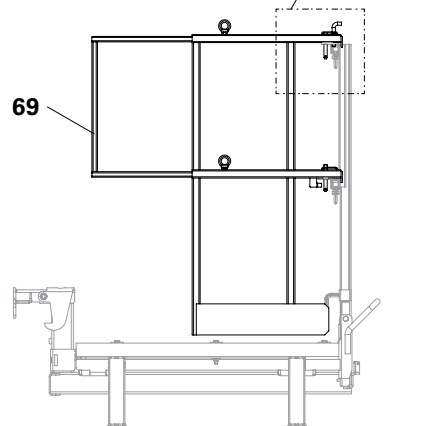


Fig. A7.09

Attaching the Concreting Platform MX 100 x 240

Attach the concreting platform to the four load-bearing points (62.6 + 62.7 – 2x each) using the 4-sling lifting gear. Ensure that the two chains which are attached to the lugs (62.7) are outside of the guardrail. (Fig. A7.10 + A7.10a + A7.10b)

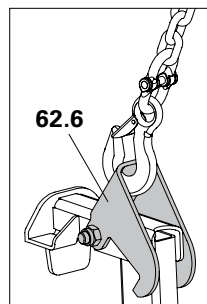


Fig. A7.10a

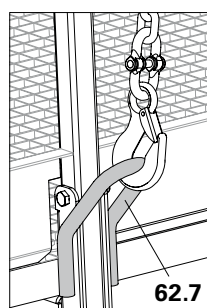


Fig. A7.10b

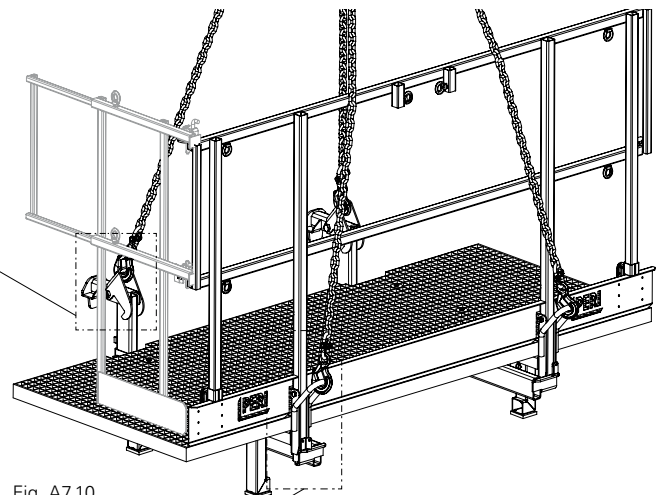


Fig. A7.10

Mounting the Concreting Platform MX 100 x 240 on the panels



Warning

Risk of injury!

⇒ Do not stand under suspended loads.

Pos.	Components	Item no.
10	Panel MX Height x width according to size	
10.7	Frame Profile	
62	Concreting Platform MX 100 x 240	127273
62.2	Suspension Beam	
62.6	Retaining Claw	
69	End Guardrail MXP	
	right	115946
	left	115945

Assembly

1. Attach the concreting platform (62) with the suspension beams (62.2) to the top frame profile of the panel.
Guide from below using guide rope.
2. Remove 4-sling lifting gear.
→ The retaining claw (62.6) grips the frame profile and the concreting platform is secured. (Fig. A7.11a + A7.11b)



Does the hook of the retaining claw (62.6) grip the frame profile (10.7) of the panel? (Fig. A7.11a)

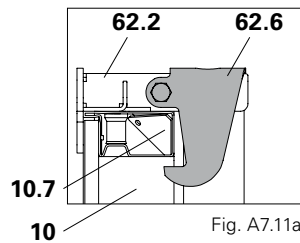


Fig. A7.11a

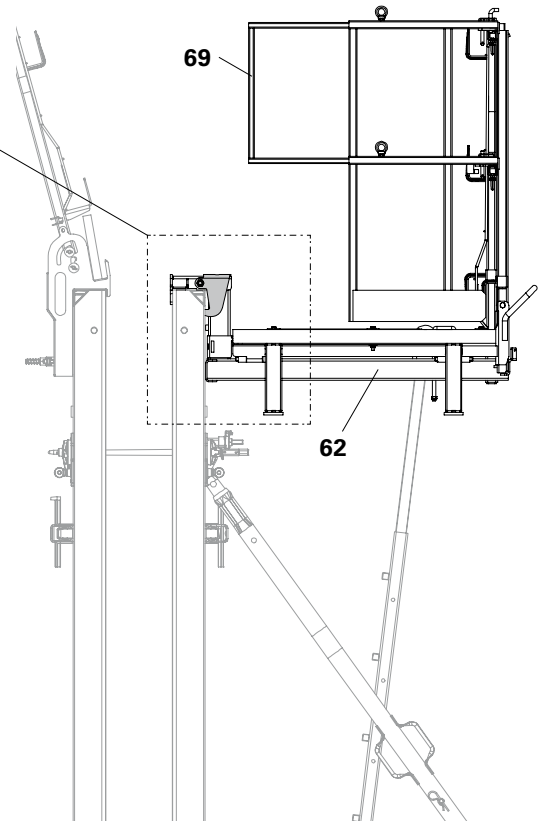


Fig. A7.11b

Concreting Platform Hatch MX 100 x 100

Pos.	Components	Item no.
63	Concreting Platform Hatch MX 100 x 100	127885
63.1	Suspension Beam	
63.2	Sliding Sleeve	
63.3	Retaining Claw	
63.4	Post Holder	
63.5	Suspension Bracket	
64	Ladder 240 – 360	107738
64.1	Hook	
67	Side Mesh Barrier PMB 90	126381
61	Guardrail Post MXK	126360

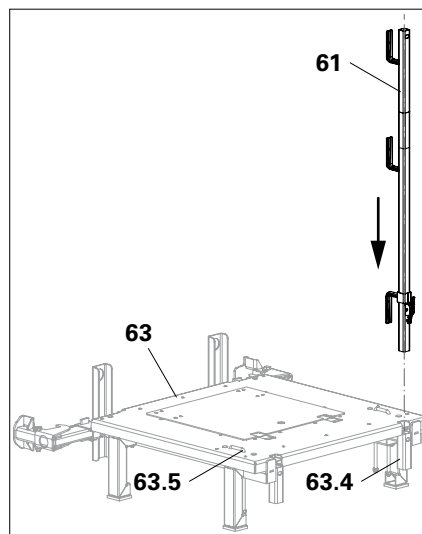


Fig. A7.12

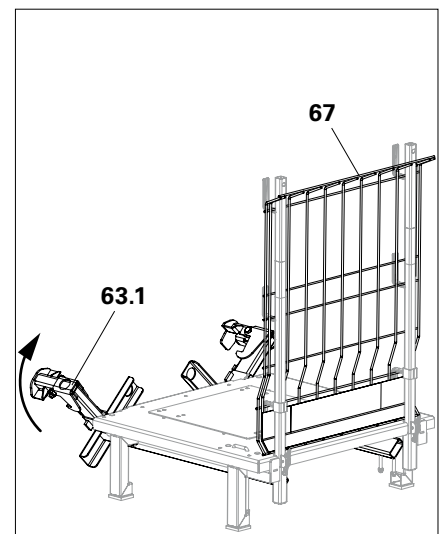


Fig. A7.13

Preparation of the Concreting Platform with Hatch

1. Insert Guardrail Post (61) in the post holder (63.4) – 2x. (Fig. A7.12)
2. Mount the Side Mesh Barrier (67). (Fig. A7.13)
3. Fold Suspension Beam (63.1) upwards. Ensure that the sliding sleeve (63.2) is at the top. (Fig. A7.13 + A7.13a + A7.13b)
4. Push the sliding sleeve downwards. (Fig. A7.13c)
→ The suspension beam is now engaged. (Fig. A7.13d)

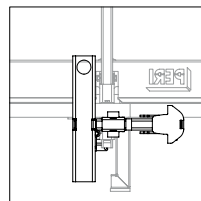


Fig. A7.13a

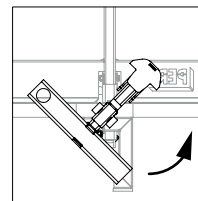


Fig. A7.13b

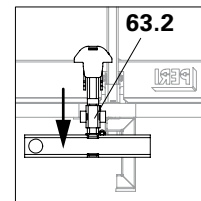


Fig. A7.13c

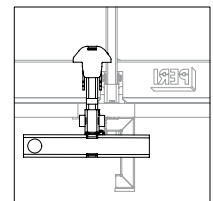


Fig. A7.13d

Attaching the Concreting Platform with Hatch

1. Take hold of the suspension bracket, pull upwards and attach to the crane hook of the 4-sling lifting gear – 2x.
2. Attach crane hook of the 4-sling lifting gear to the suspension beam (63.3) – 2x. (Fig. A7.14 + A7.14a + A7.14b)

→ The chains are positioned inside of the Side Mesh Barrier.

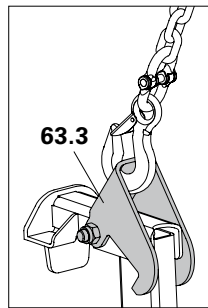


Fig. A7.14a

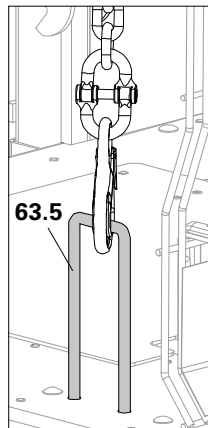


Fig. A7.14b

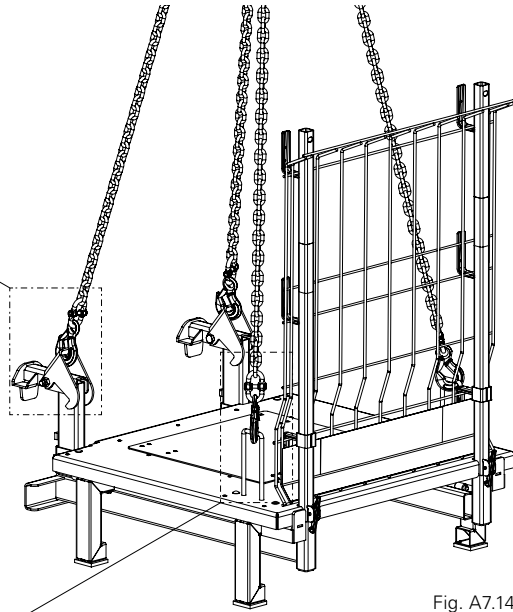


Fig. A7.14

Mounting the Concreting Platform with Hatch on the panels



Warning

Risk of injury!

⇒ Do not stand under suspended loads.

Assembly

1. Guide from below using guide rope. (Along the same lines as the Concreting Platform MX 100 x 240).
2. Remove 4-sling lifting gear.
 - The retaining claw (63.3) grips the frame profile and the concreting platform is secured. (Fig. A7.17)

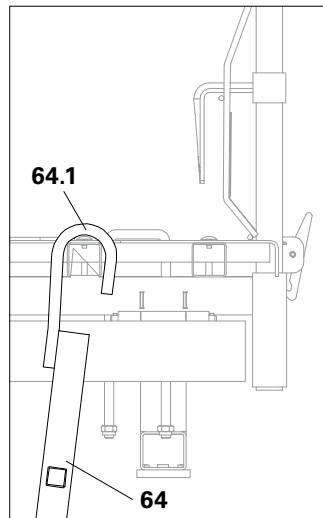


Fig. A7.15

Assembly of Ladder 240-360

1. Adjust Ladder to the required length and secure using a linch pin.
2. If the Ladder is too long, remove the base.
3. From below, push the Ladder with the hooks (64.1) through the openings of the hatch cover.
 - Cover of the hatch opens.
4. Push the hooks (64.1) of the Ladder over the cross beam of the concreting platform. (Fig. A7.15)
 - Ladder is now securely attached. (Fig. A7.16)

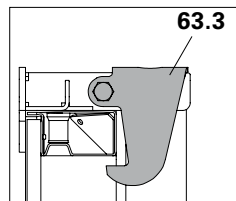


Fig. A7.17

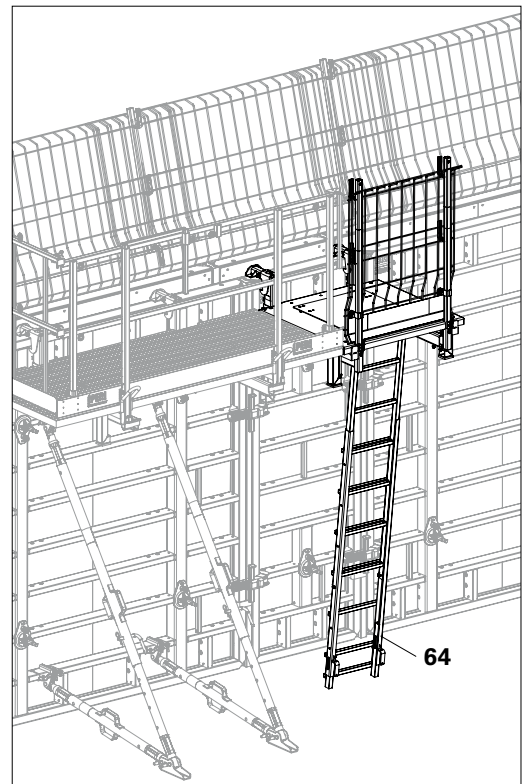


Fig. A7.16



Does the hook of the retaining claw (63.3) grip the frame profile of the panel (10.7)? (Fig. A7.17)

Installing the Concreting Platform with Hatch at 90° inside corners

Use the Concreting Platform Hatch MX 100 x 100 (63) for 90° corners on the internal formwork. Subsequently, mount the Concreting Platform MX 100 x 240 (62) in both directions.

(Fig. A7.18)

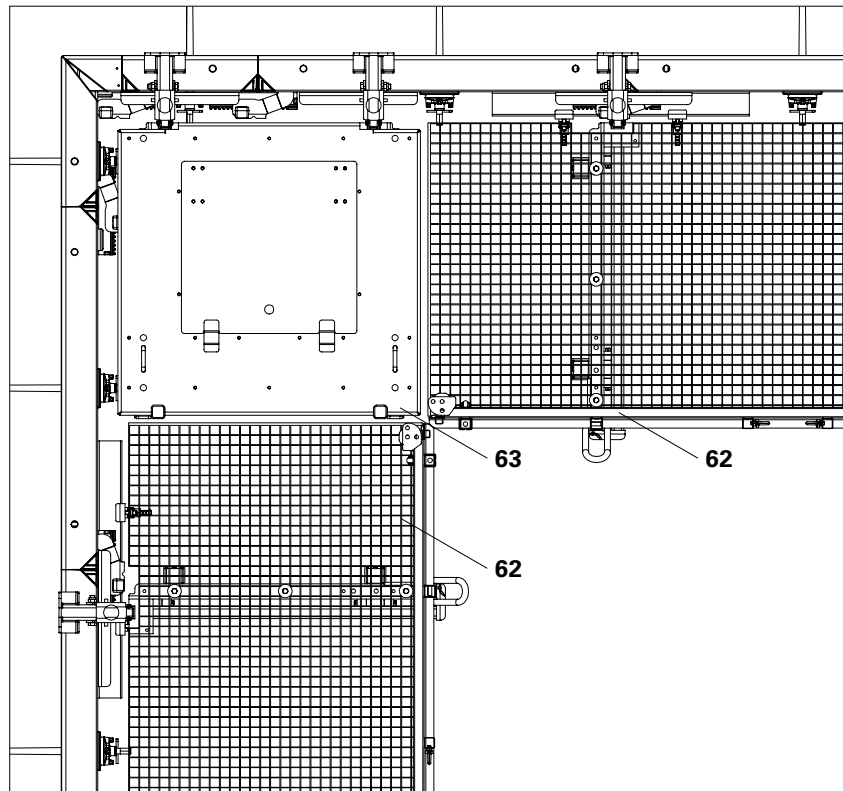


Fig. A7.18

Concreting Platform TRIO 120 x 270



Warning

Risk of injury!

⇒ The Concreting Platform TRIO 120 x 270 must be dismantled during temporary storage of the panels.

Perm. load: 150 kg/m²

Load Class 2 according to DIN EN 12811-1.



The load-bearing points of the Concreting Platform TRIO 120 x 270 are coloured yellow.

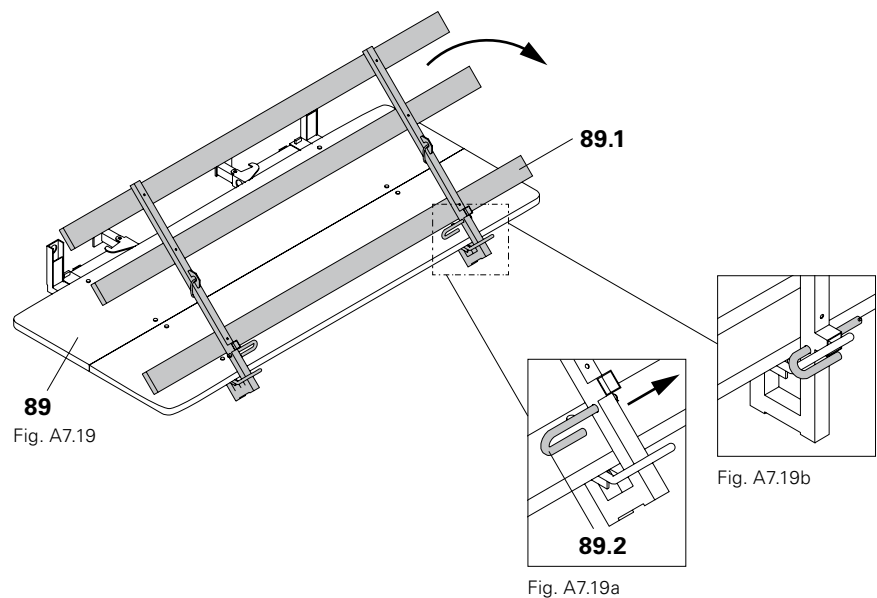
Pos.	Components	Item no.
10	MAXIMO Panel according to size	
10.7	Frame Profile	
89	Concreting Platform TRIO 120 x 270	022950
89.1	Guardrail	
89.2	Bolt	
89.3	Suspension Beam	
89.4	Sliding Sleeve	
89.5	Retaining Claw	

Perm. load: 150 kg/m

Load Class 2 according to DIN EN 12811-1.

Preparation

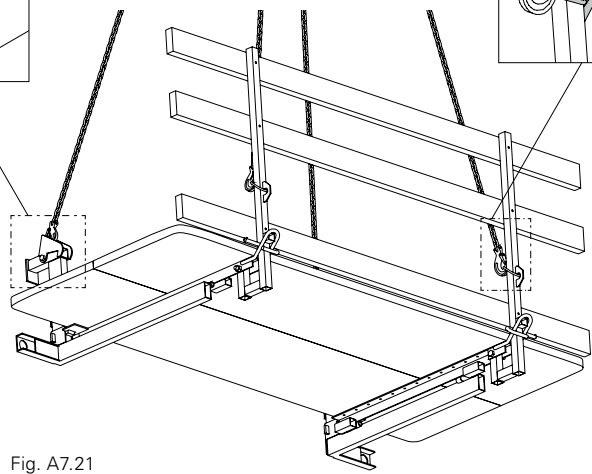
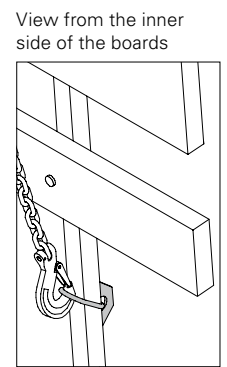
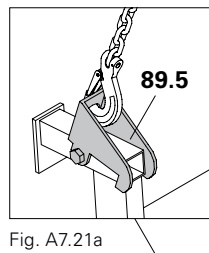
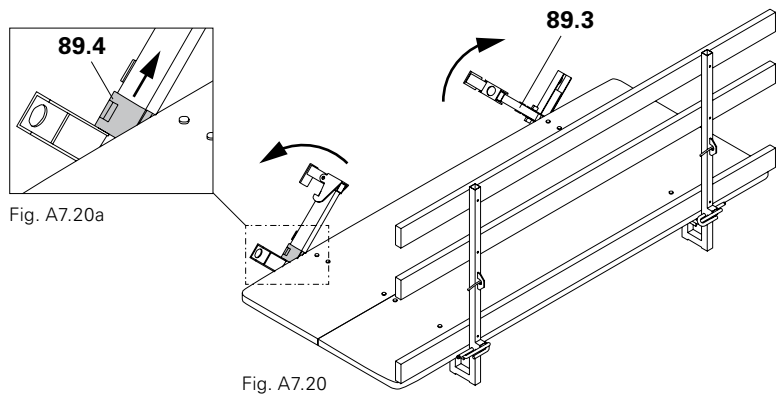
1. Fold up guardrail (89.1). (Fig. A7.19)
2. Secure guardrail with bolts (89.2). (Fig. A7.19a + A7.19b)





Is the sliding sleeve (89.4) in position above?
(Fig. A7.20 + Fig. A7.20a)

3. Fold up suspension beam (89.3) until it engages.
4. Attach 4-sling lifting gear to the TRIO Concreting Platform.
(Fig. A7.21 + A7.21a + A7.21b)



Warning

Risk of injury!

⇒ Do not stand under suspended loads.

Assembly on panel

1. Attach the TRIO Concreting Platform with the suspension beams to the top frame profile. Guide from below using guide rope. (Fig. A7.22)
2. Remove 4-sling lifting gear.
 - The retaining claw (89.5) grips the frame profile (10.7) and secures. (Fig. A7.23 + Fig. A7.23a)



Does the hook of the retaining claw grip the frame profile (10.7)? (Fig. A7.23a)

3. Attach side protection, e.g. End Guardrail Frame 55.

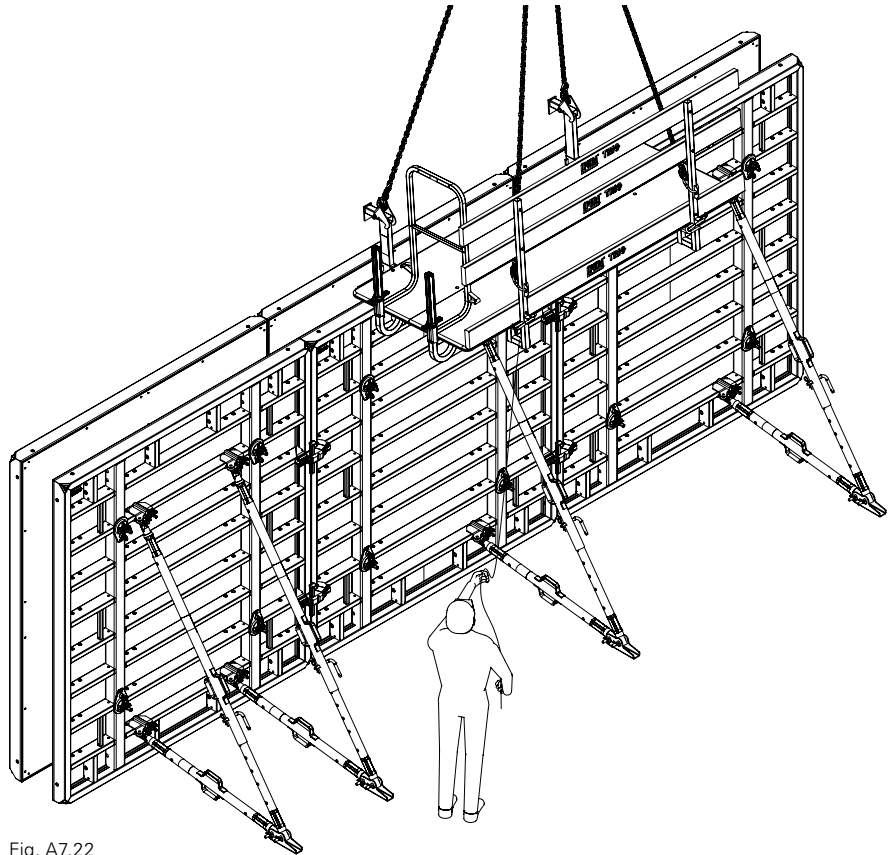


Fig. A7.22

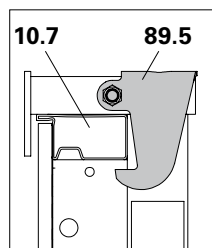


Fig. A7.23a

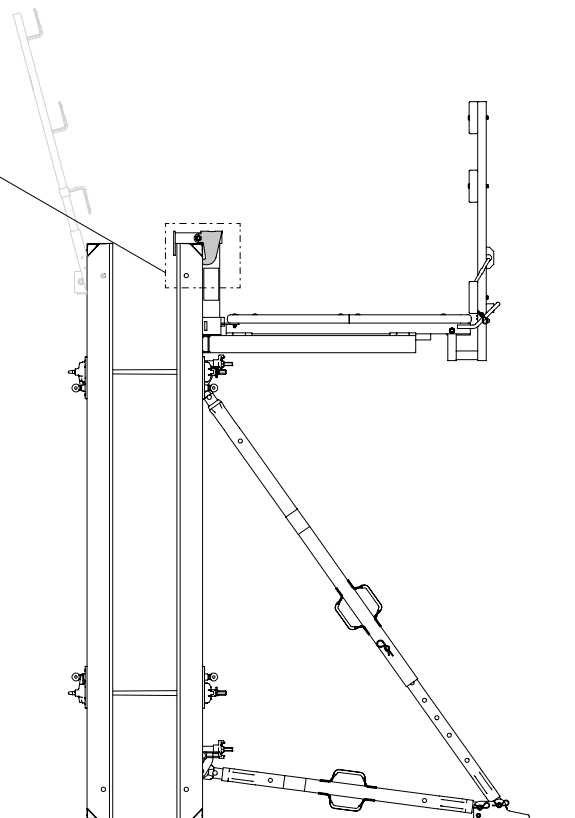


Fig. A7.23

Place guardrail in an inclined position



Always place guardrail in an inclined position before moving with the crane.

Pos.	Components	Item no.
89	Concreting Platform TRIO 120 x 270	022950
89.1	Guardrail	
89.2	Bolt	

Assembly

1. Remove securing pin and cotter pin (89.2). (Fig. A7.24a + A7.24b)
2. Incline the guardrail (89.1) backwards, max. 15°. (Fig. A7.24c)
3. Install securing pins and secure with cotter pin.
→ Guardrail is now in an inclined position. (Fig. A7.24d)

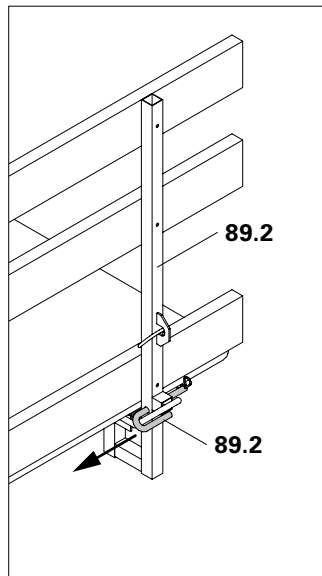


Fig. A7.24a

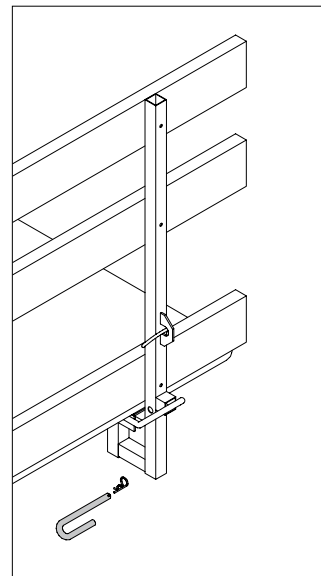


Fig. A7.24b

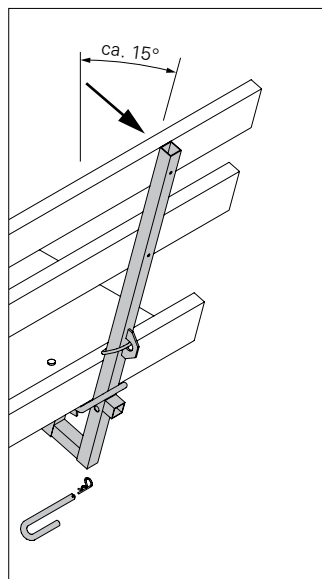


Fig. A7.24c

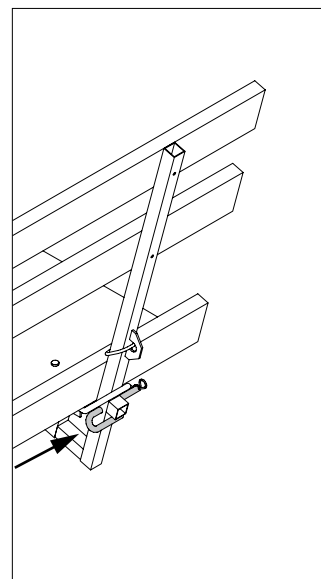


Fig. A7.24d

Handrail Post Holder MX



- The Handrail Post Holder MX is fitted to the top frame profile of a Panel MX and used as anti-fall protection.
- Mount the Handrail Post Holder MX and Side Mesh Barrier PMB on the ground.
- Follow Instructions for Use for the Lifting Hook MAXIMO 1.5 t.

Technical data

Max. width of influence 1.80 m

Pos.	Components	Item no.
10	Panel MX Height x width	acc. to size
10.7	Top Frame Profile	
13	Lifting Hook MAXIMO 1.5 t	115168
66	Handrail Post Holder MX	129960
66.1	Mounting Shoe	
66.2	Double Hook	
66.3	Wingnut DW 15	
66.4	Handrail Post	
66.5	L-Angle – 3x	
66.6	Safety Hook	
66.7	Linch Pin	
67	Side Mesh Barrier	
	PMB 90	126381
	PMB 120	126376
	PMB 240	126371

Mounting the Handrail Post Holder MX

1. Slide mounting shoe (66.1) of the Handrail Post Holder MX over the top frame profile (10.7).
2. Insert double hooks (66.2) of the Handrail Post Holder (66) into the connecting holes of the panel.
 - Horizontal strut (Fig. A7.25a + A7.25b)
 - Vertical strut (Fig. A7.25c + A7.25d)
3. Tighten wingnut (66.3). (Fig. A7.26b)

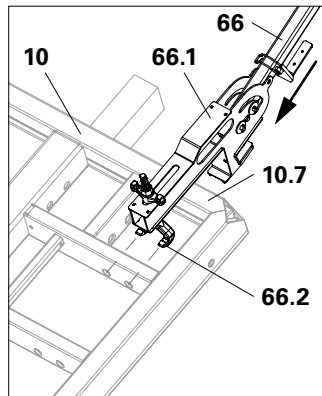


Fig. A7.25a

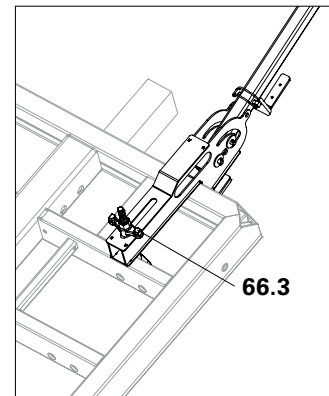


Fig. A7.25b



- Is the double hook completely engaged in the connecting holes?
- Has the wingnut been securely tightened?
→ Handrail Post Holder is therefore prevented from falling out.



For assembly, the Ratchet MX 15 can be used. (Fig. A7.25e)

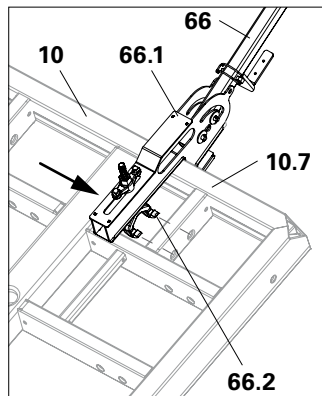


Fig. A7.25c

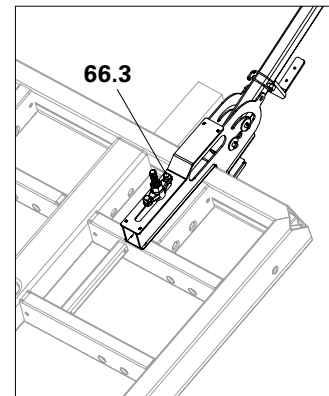


Fig. A7.25d

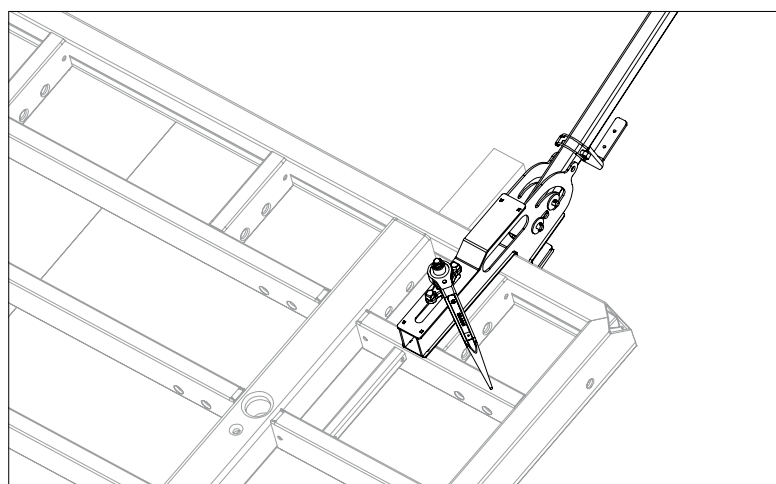


Fig. A7.25e

Mounting the Side Mesh Barrier



- Overlap of the Side Mesh Barrier: max. 60 cm
- Total length of the pre-assembled side mesh barrier unit when overlapped: max. 6.00 m
- Lateral cantilever of the Side Mesh Barrier: max. 30 cm

Assembly

1. Guardrail Post (66.4)
 - 1- raise horizontally,
 - 2- pull out (Fig. A7.26a + b + c) and
 - 3- position (Fig. A7.26b).
 - Guardrail Post is now in its designated position. (Fig. A7.26d)
2. Mount the Side Mesh Barrier (67) in the L-Angles (66.5). (Fig. A7.27)
3. Secure top horizontal member of the Side Mesh Barrier (67.1) in the recess with the help of the securing hook (66.6). (Fig. A7.27a)
4. Position Guardrail Post including Side Mesh Barrier face downwards. (Fig. A7.27 + A7.28)
5. Lift Guradrail Post with Side Mesh Barrier in a horizontal position and press in the direction of the formwork panel.
 - Bolts are at the rear, see Fig. A7.28a.



Are the bolts in the position as shown in Fig. A7.28a?

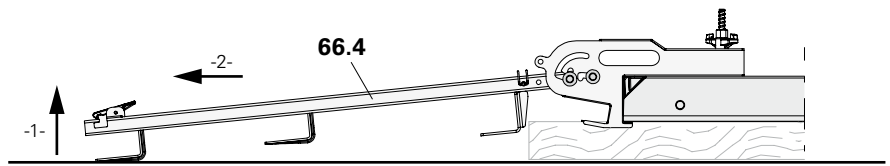


Fig. A7.26a

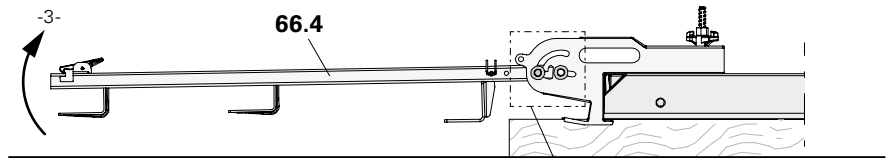


Fig. A7.26b

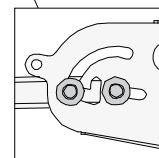


Fig. A7.26c

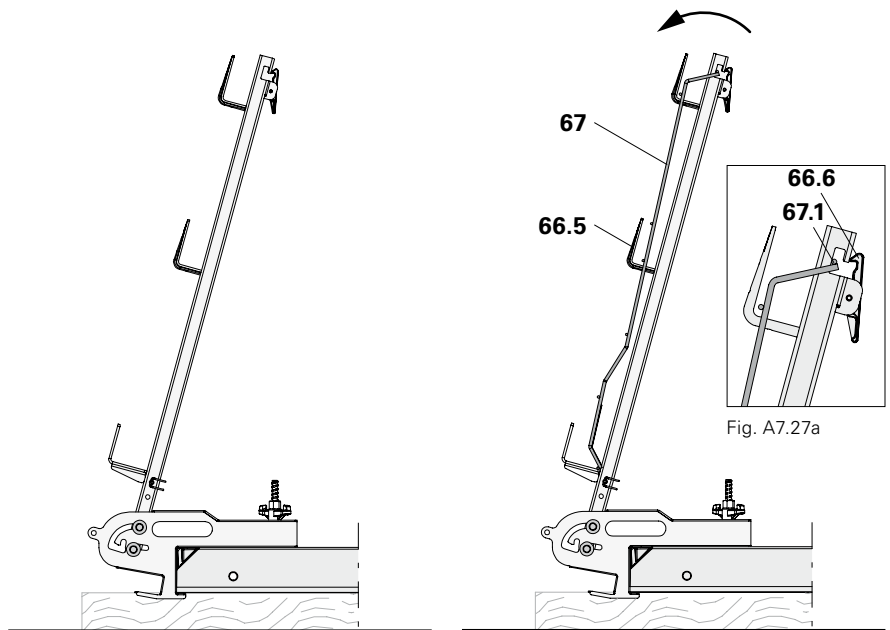


Fig. A7.26d

Fig. A7.27

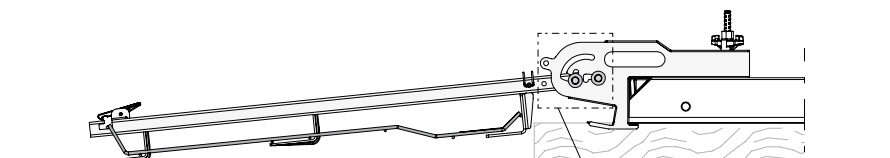


Fig. A7.28

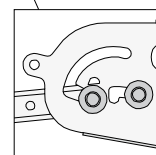


Fig. A7.28a

Erecting and securing the panel

1. Mount Lifting Hook (13). Ensure that the crane lifting chains are in front of the Side Mesh Barrier. (Fig. A7.29a)
2. Erect panel (10). (Fig. A7.29a + A7.29b)
3. When the panel is positioned securely, remove the Lifting Hook from a safe working position, e.g. working platform.
4. Fold back the Guardrail Post with the Side Mesh Barrier. (Fig. A7.29b + A7.30)
5. Remove linch pin (66.7) from Position A. (Fig. A7.30a)
6. Install linch pin in Position B. (Fig. A7.31a)
→ Guardrail Post is now secured against tipping. (Fig. A7.31)

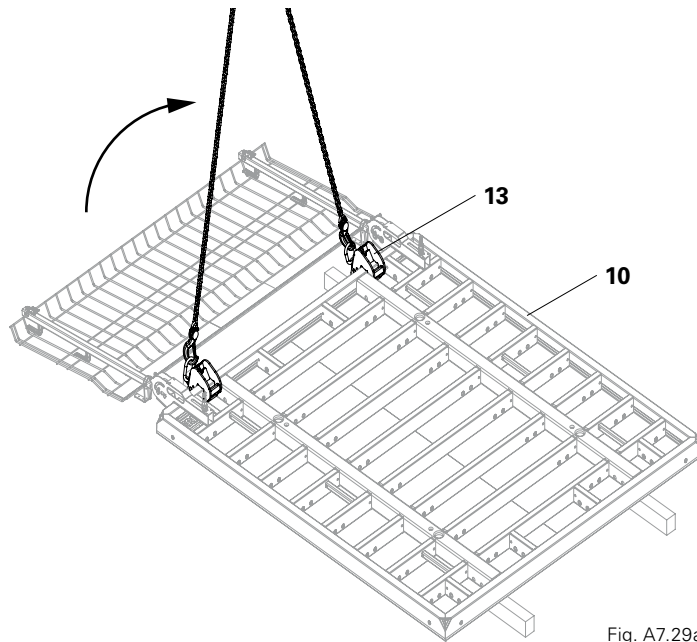


Fig. A7.29a



Instead of the Side Mesh Barrier PMB, three wooden boards can be placed in the L-angles as guardrails, and secured using nails. (not shown)

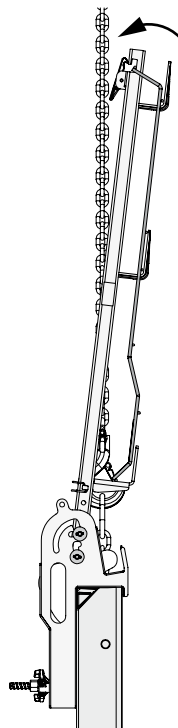


Fig. A7.29b

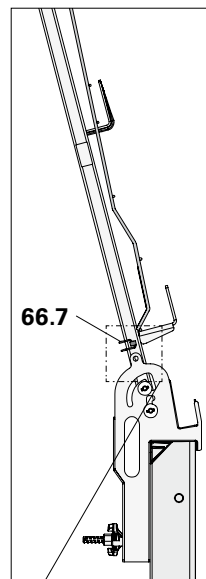


Fig. A7.30

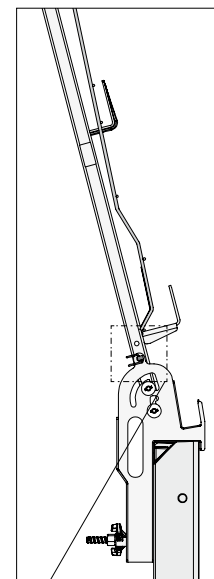


Fig. A7.31

A - placing position
B - secured position

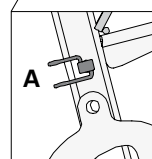


Fig. A7.30a

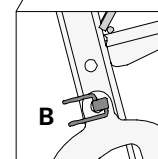


Fig. A7.31a

Laying down, cleaning, erecting and securing the panel

1. Mount Lifting Hook. Ensure that the crane lifting chains are in front of the Side Mesh Barrier. (On the formlining side.) (Fig. A7.32)
2. Remove linch pin (66.7) from Position B. (Fig. A7.34a)
3. Install linch pin (66.7) in Position A. (Fig. A7.33a)
4. Place panel on the frame side.
5. Clean and oil panel.
6. Erect panel (10). When the panel is positioned securely, remove the Lifting Hook from a safe working position, e.g. working platform.
7. Fold back Guardrail Posts including Side Mesh Barrier. (Fig. A7.33)
8. Remove linch pin (66.7) from Position A. (Fig. A7.33a)
9. Install linch pin in Position B. (Fig. A7.34a)
 - Guardrail Post is now secured against tipping. (Fig. A7.34)

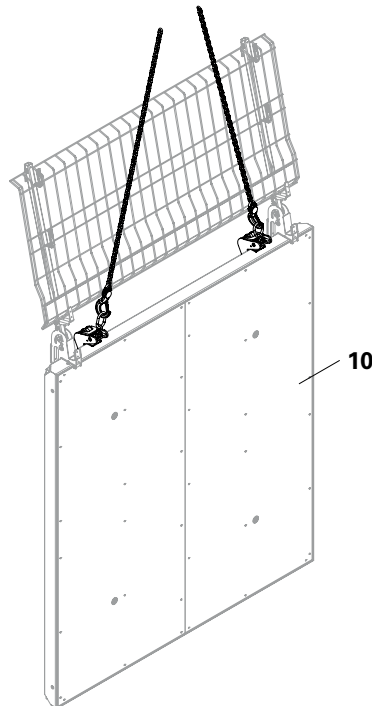


Fig. A7.32

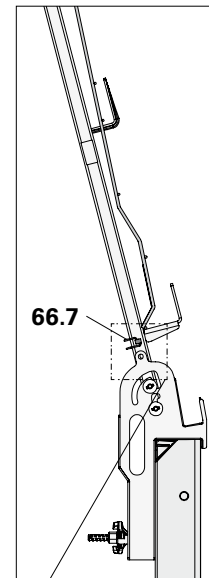


Abb. A7.33

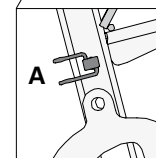


Fig. A7.33a

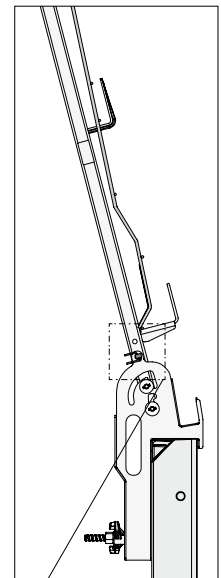


Fig. A7.34

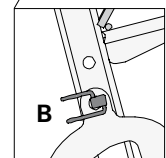
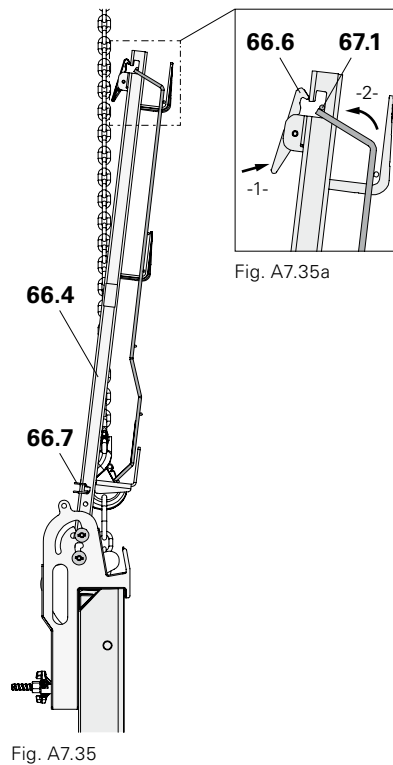


Fig. A7.34a

Dismantling opposing guardrails

1. Remove linch pin (66.7) from Position B. (Fig. A7.34a)
→ Opposing guardrail can move freely.
2. Install linch pin (66.7) in Position A. (Fig. A7.33a)
→ Linch pin is in the placing position.
3. Fold forward Guardrail Posts with Side Mesh Barrier.
4. Mount Lifting Hook. Ensure that the crane lifting chains are behind the Side Mesh Barrier. (On the frame side) (Fig. A7.35)
5. Lay down panel on the formlining side.
6. Lift Guardrail Posts (66.4) with Side Mesh Barrier in a horizontal position then pull out and erect.
→ Guardrail Post is now in its designated position.
7. Press securing hook – 1 – and – 2 – remove top horizontal member of the Side Mesh Barrier (67.1) from the recess (Fig. A7.35a).
8. Remove Side Mesh Barrier upwards from the L-angles.



Guardrails with boards

Technical data

Max. width of influence 1.80 m



Warning

Risk of injury!

⇒ Secure boards with nails.



Assembly is only possible on vertical panel struts.

Pos.	Components	Item no.
257	Guardrail Post Holder TRIO	101592
258	Guardrail Post HSGP-2	116292

(Fig. A7.36 + A7.36a)

Assembly

1. Hook in Guardrail Post Holder (257) into the connecting holes of the panels.
2. Secure with cotter pin.
3. Insert Guardrail Posts (258). (Fig. A7.36)
4. Install guardrail boards and secure with nails. (Fig. A7.37 + A7.38)

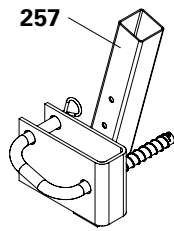


Fig. A7.36a

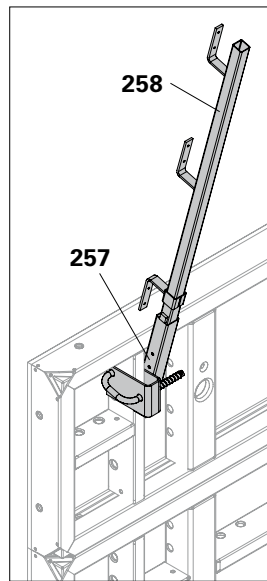


Fig. A7.36

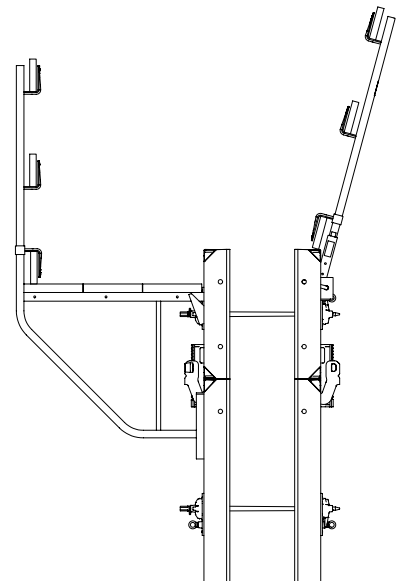


Fig. A7.37



- When erecting, make sure that the guardrails are not damaged by the lifting gear.
- With extended formwork units, guardrails are mounted on horizontally-positioned panels as part of the pre-assembly process.
- When dismantling Panel MX, do not lay on the Guardrail Post Holder.
- Shown without Push-Pull Props.



The Side Mesh Barrier PMB can be installed instead of boards.

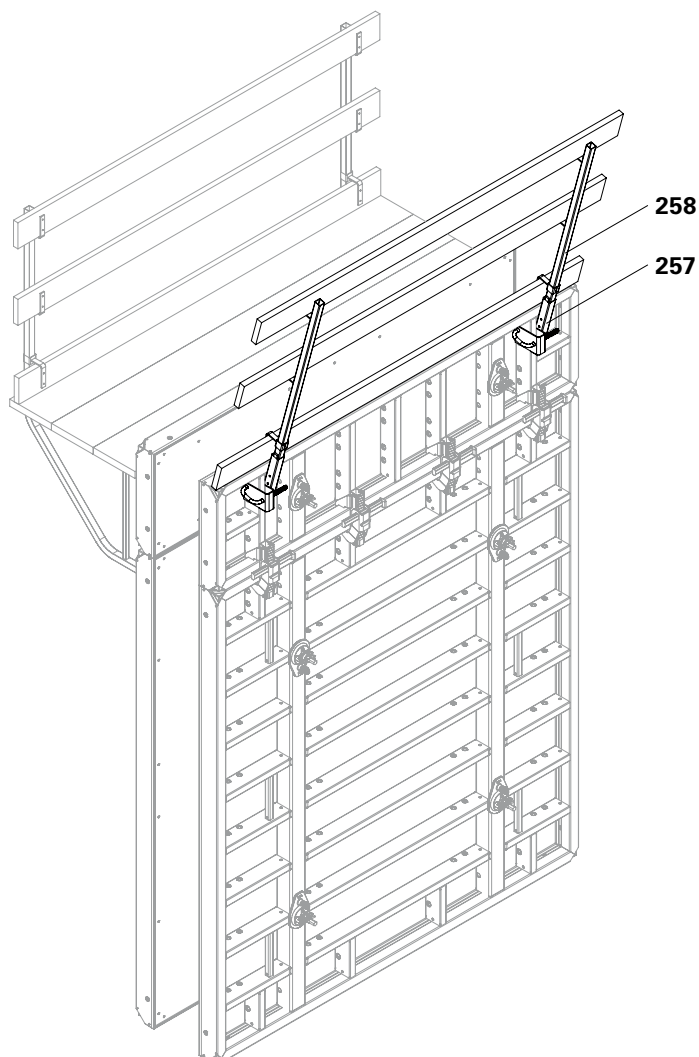


Fig. A7.38

Downward extension panels Horizontal downward extension panels up to 2.10 m high

MX...30

(Fig. A8.01)

Pos. Components

- 20** Alignment Coupler BFD
- 21** Compensation Waler MAR 85-3



Install 6 Alignment Couplers BFD as panel connections with Downward Extension Panel MX...30.
(Fig. A8.01)

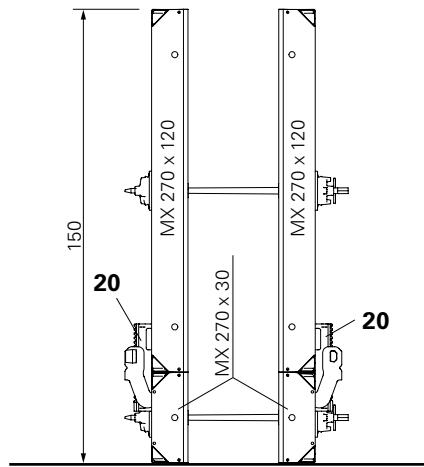


Fig. A8.01

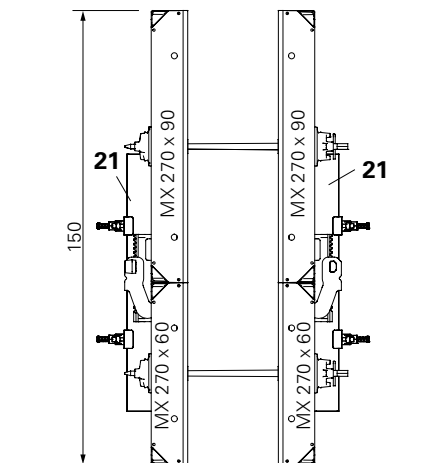


Fig. A8.02

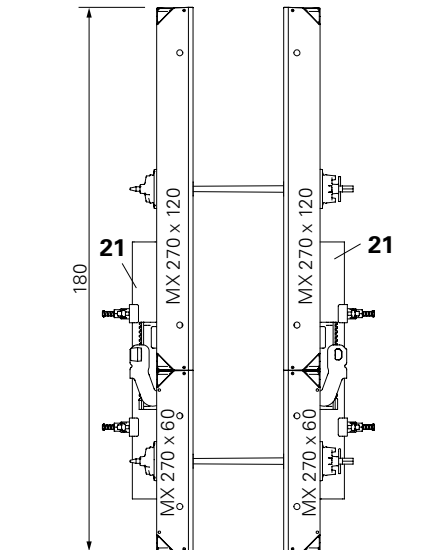


Fig. A8.03

MX...90

(Fig. A8.04 + A8.05)

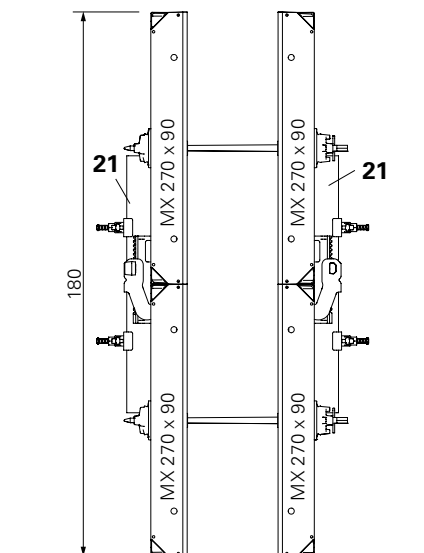


Fig. A8.04

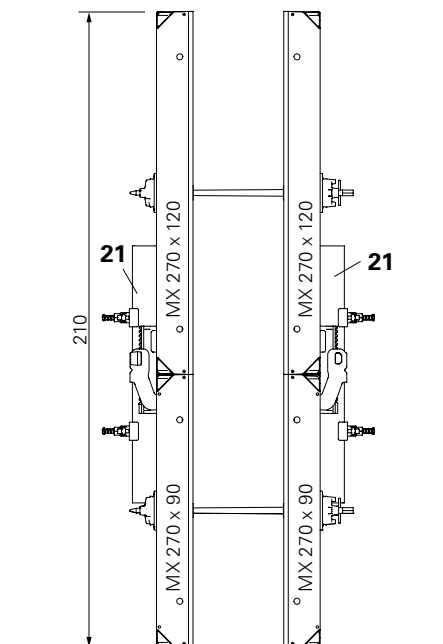


Fig. A8.05

A8 Downward extensions

Arrangement of panel connections

Pos.	Components	Qty.
20	Alignment Coupler BFD	2x
21	Compensation Waler MAR 85-3	2x

Example:
 MAXIMO Panel MX 270 x 60 and
 MAXIMO Panel MX 270 x 90
 (Fig. A8.06)

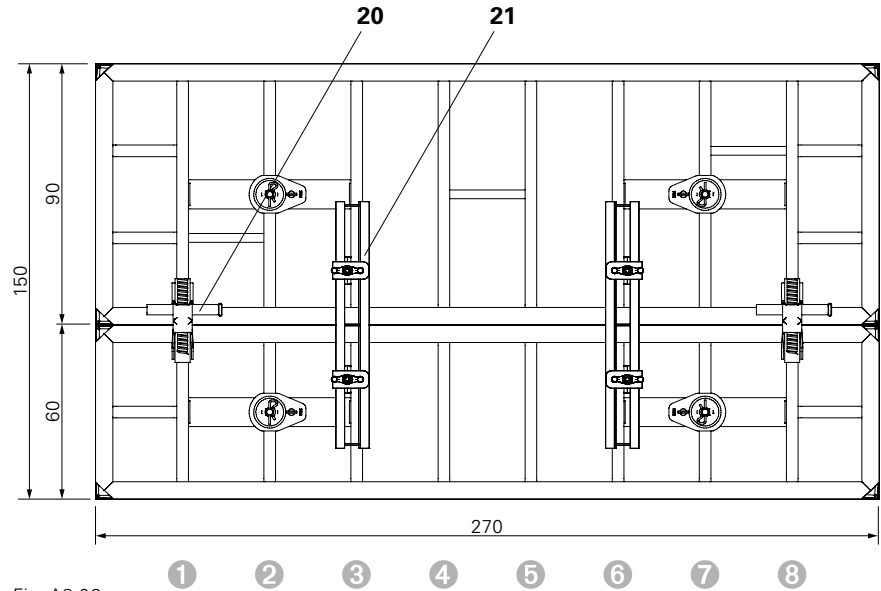


Fig. A8.06

Panel connection	Panel strut
BFD (20)	1 8
MAR 85 (21)	3 6

Tension and Compression Brace MX 15-40 and MX 15-100

Depending on the wall thickness, the table shows which Tension and Compression Braces and anchor fastenings can be used.

Wall thickness	Tension and Compression Brace		Tie MX 15	Tie Rod DW 15
	MX 15-40	MX 15-100		
≤ 40 cm	X	X	X	X
≤ 60 cm	-	X	-	X
≤ 100 cm	-	X	-	X

Perm. tension and compression force = 9 kN.

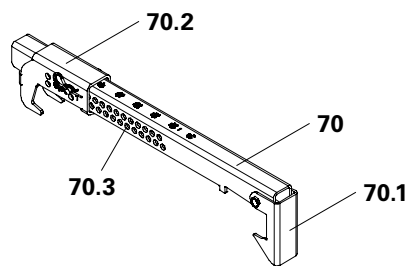
For max. height 1.20 m, e.g. parapets.



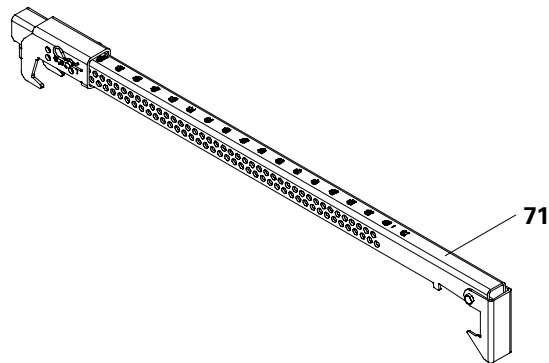
Adjust Tension and Compression Brace to: setting dimension = wall thickness + 5 mm.

Wall thickness

- Wall thickness ≤ 40 cm: MX 15-40 (Fig. A9.01)
- Wall thickness ≤ 100 cm: MX 15-100 (Fig. A9.02)

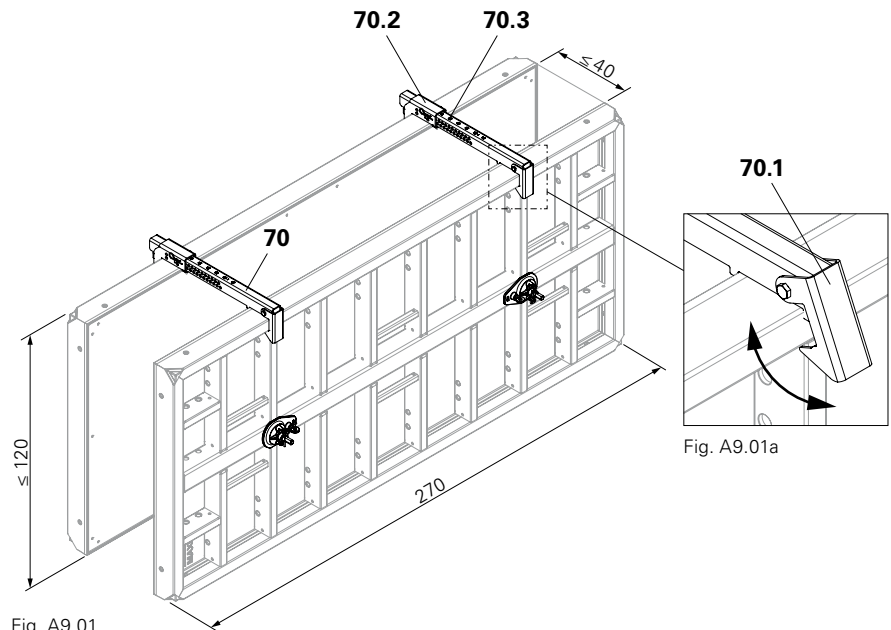


Pos.	Components	Item no.
70	Tension and Compression Brace MX 15-40	115350
70.1	Safety Hook	
70.2	Mounting Shoe	
70.3	Spacer Rack	
71	Tension and Compression Brace MX 15-100	123842



Preparation

- Adjust mounting shoe (70.2) of the Tension and Compression Brace to required setting dimension:
 - Remove cotter pin from bolt.
 - Pull bolt out of spacer rack.
 - Slide holes of the mounting shoe (70.2) and spacer rack (70.3) on top of each other according to the setting dimension.
 - Insert bolts through holes.
 - Insert cotter pin into the hole of the bolt.
- Pivot safety hook (70.1) of the Tension and Compression Brace upwards. (Fig. A9.01a)
 - Tension and Compression Brace is now opened for positioning.
- Oil spacer rack (70.3).

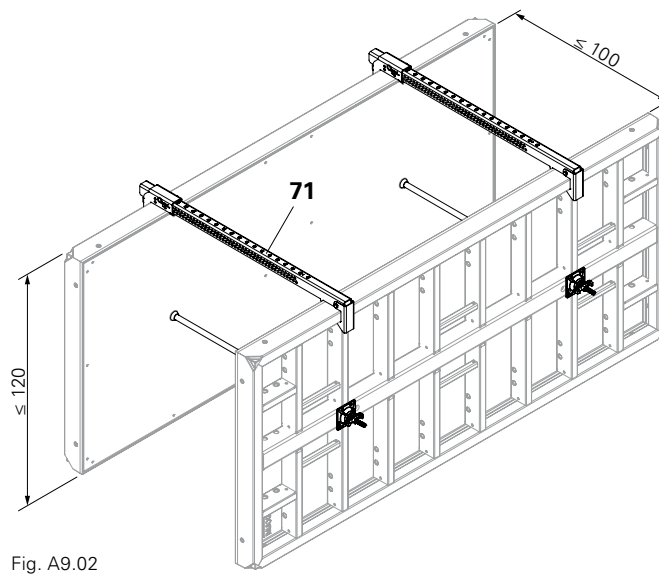


Assembly

- Place Tension and Compression Brace on the panel in the area of the tie point; at the same time, mount the mounting shoe (70.2) in the edge profile of the formwork.
- Press the safety hook (70.1) downwards over the edge profile and panel strut of the formwork.
 - Tension and Compression Brace is now locked in position.



Clean the spacer rack of the Tension and Compression Brace after concreting.



Panel MX 270 x 240 horizontal
(Fig. A9.03)



- Perm. fresh concrete pressure 60 kN/m²
- Perm. tension and compression force = 9 kN
- Adjust Tension and Compression Brace to: setting dimension = wall thickness + 5 mm.

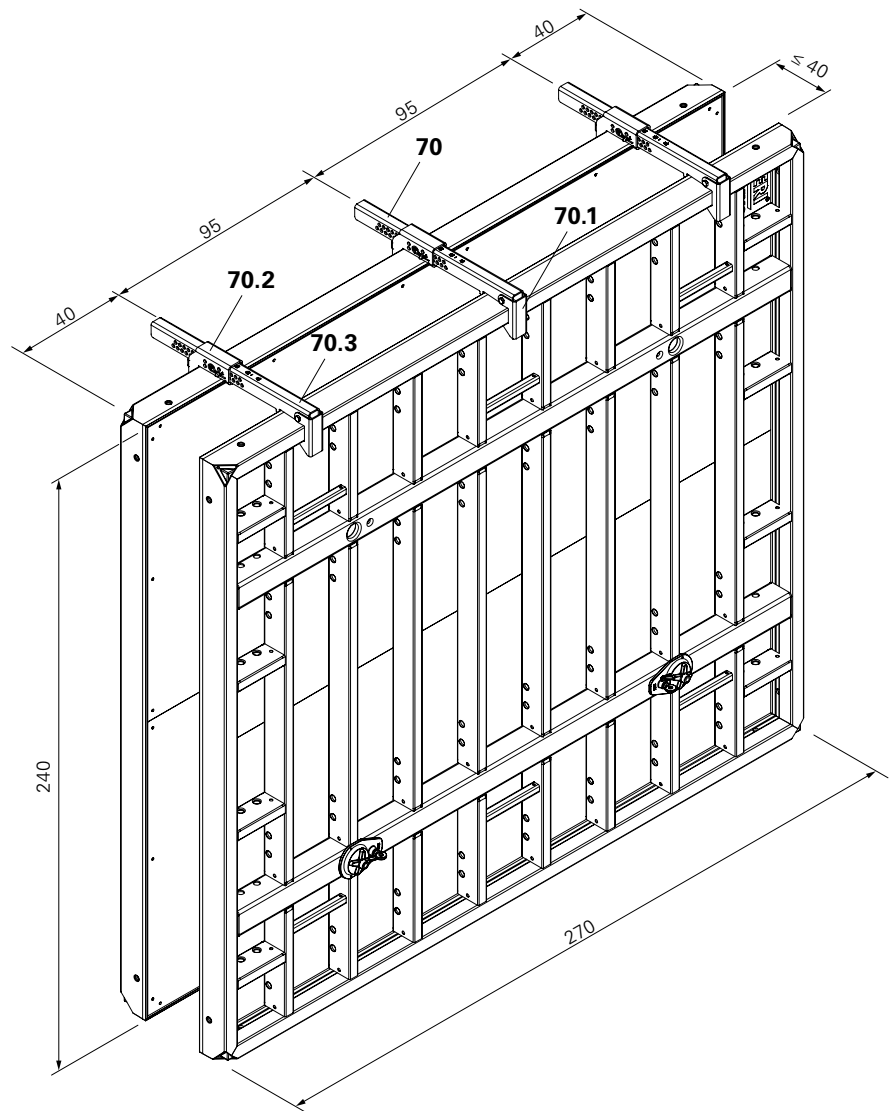


Fig. A9.03



Tension and Compression Brace on Panel MX 330 x 240, see Section C11.

Tie System DW 15

(Alternative)

Pos.	Components	Qty.
10	Panel MX height x width	2x
25	Tie Rod DW 15	2x
27	Top Tie Bracket-2 AH	4x
44	Wingnut DW 15	4x
73	Foundation Tie Clamp TRIO	4x
74	Plug MXM 15, Ø 18.3	4x
78	Perforated Foundation Tie	2x

Assembly

1. Mount Top Tie Bracket-2 AH (27) and Foundation Tie Clamp TRIO (73).
(Fig. A9.04 + Fig. A9.04a)
2. Close all open tie holes on the form-lining side with Plugs MXM 15 (74),
Item no. 124895.

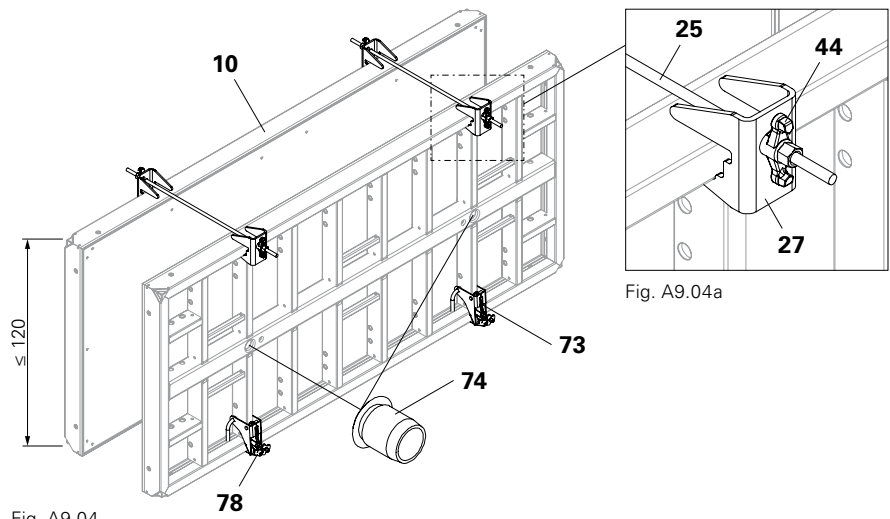


Fig. A9.04

Fig. A9.04a

Foundation Strap TRIO

Item no. 023800

The Foundation Strap (75) is used for forming individual foundations using the "windmill configuration". (Fig. A9.05)

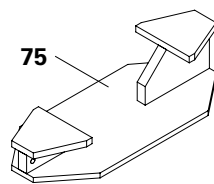


Fig. A9.05

Pos.	Components	Qty.
10	Panel MX height x width	4x
75	Foundation Strap TRIO	8x
76	Locating Board	4x

H [cm]	perm. B [cm]
60	255
90	200



$$L = H - 10 \text{ cm}$$

L = length of locating board

H = height of the panel

Example: with a panel height of 60 cm,
the length of the locating board is 50 cm.

Assembly

1. Place two panels (10) at right angles to each other on the ground in a Foundation Strap (75).
2. Nail locating board (76) to formlining
 - with spacing $B + 12$ cm as well as
 - 5 cm from the edge of the panel at the top and bottom.
3. Place the Foundation Strap (75) on the edge of the panel on the protruding panel.
4. Slide Foundation Strap as far as possible on the offset panel.
 - Upper web rests against the panel.
 - (Fig. A9.06a)
5. Install additional panels, locating boards and Foundation Straps. (Fig. A9.06)

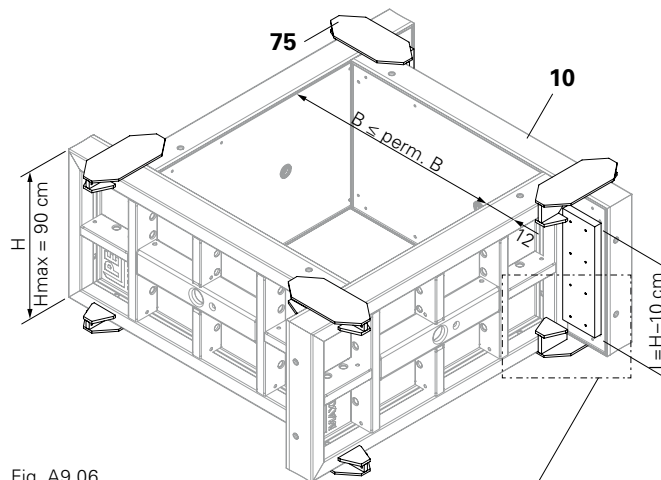


Fig. A9.06



Are the Foundation Straps lying flat on the panels - 4x above and 4x bottom? (Fig. A9.06a)

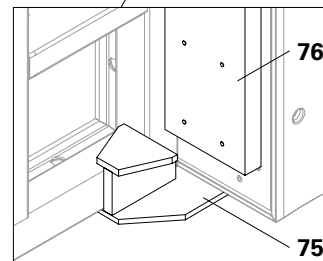


Fig. A9.06a

A10 Height offsets

With height offsets, depending on the offset, mount the Alignment Coupler BFD as much as possible alternately on the panel struts (10.2) of the right and left panels. (Fig. A10.01)

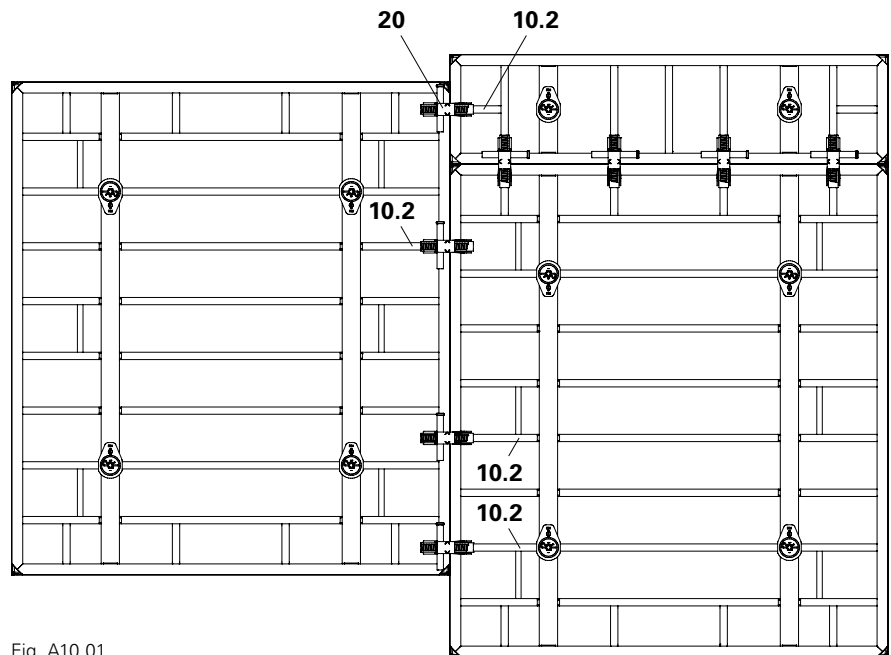


Fig. A10.01



Not permissible for other formwork systems.

Panel heights

Different panel heights allow fast striking and moving of the shaft formwork.

- 1.20 m (Fig. A11.01a)
- 2.70 m (Fig. A11.01b)
- 3.30 m (Fig. A11.01c)

Pos.	Components	Item no.
80	Shaft Corner MXSE, height	
80.1	Tie Point	
80.2	Load-bearing point 2 t	
80.3	Bolt and cotter pin	
80.4	Openings for shuttering and striking	
80.5	Positioning Water MXSE	
80.6	Hole of the lug	
81	Shaft Corner MXSE 120	117915
82	Shaft Corner MXSE 270	117914
84	Shaft Corner MXSE 330	117913

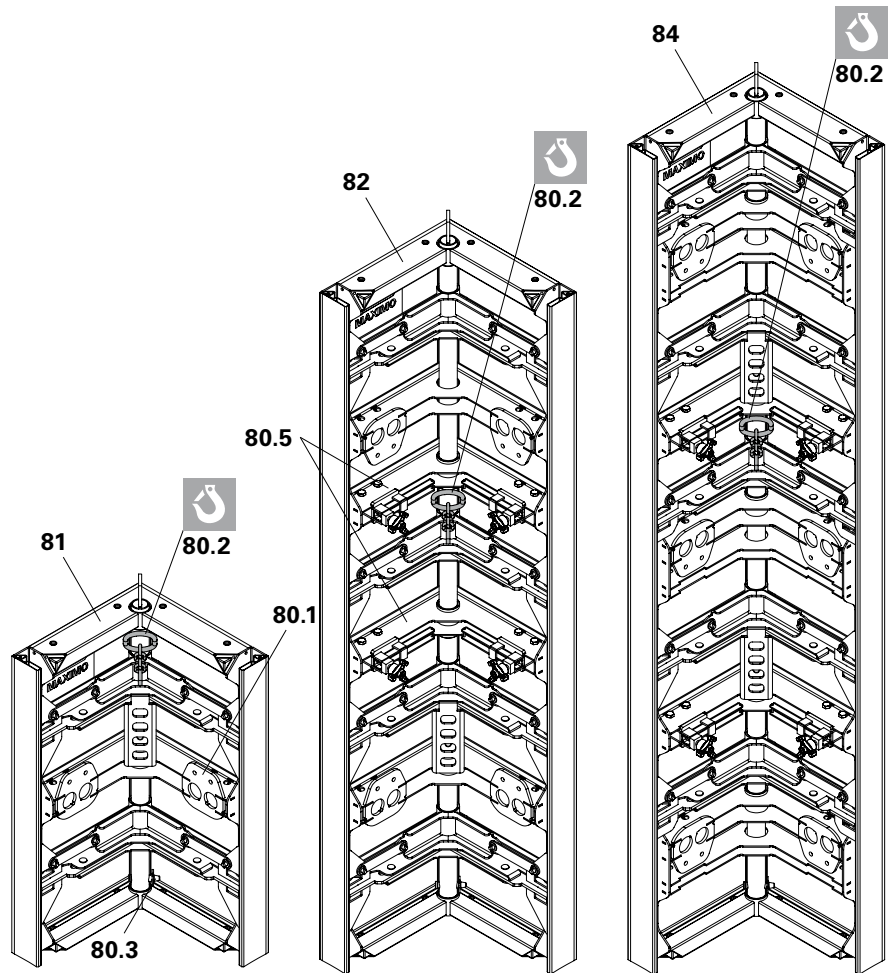


Fig. A11.01a

Fig. A11.01b

Fig. A11.01c



Horizontally pre-assemble the shaft formwork. (Fig. A11.02a)



Do not attach the crane hook into the lug hole (80.6)! (Fig. A11.01d)

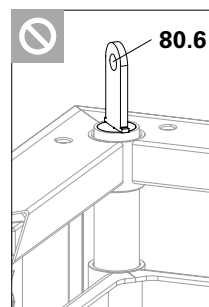


Fig. A11.01d

Crane suspension



Warning

Risk of injury!

- ⇒ Perm. load-bearing capacity of the lifting hook: 1.5 t.
- ⇒ Follow Instructions for Use for the Lifting Hook MAXIMO 1.5 t.

Lifting Hook MAXIMO 1.5 t

For use with:

- two Shaft Corners MXSE, height 270/330 (82/84) and
- two Inside Corners MXI, height 270/330 x 50/20 (153/161).

(Fig. A11.02a + A11.02b)

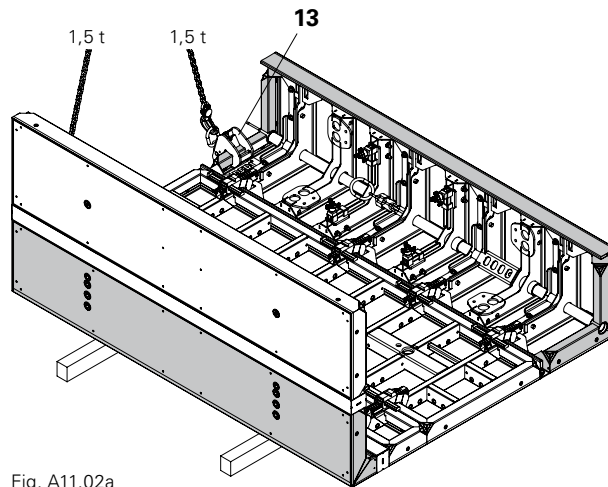


Fig. A11.02a

Pos.	Components	Qty.
13	Lifting Hook MAXIMO 1.5 t	2x
	with	
82	Shaft Corner MXSE 270	2x
153	Inside Corner MXI 270 x 50/20	2x
	or	
84	Shaft Corner MXSE 330	2x
161	Inside Corner MXI 330 x 50/20	2x

For use with:

four Shaft Corners MXSE, height 270/330 (82/84). (not shown)

Pos.	Components	Qty.
11	Lifting Gear Combi MX	1x
	with	
82	Shaft Corner MXSE 270/330	4x
	or	
84	Shaft Corner MXSE 270/330	4x

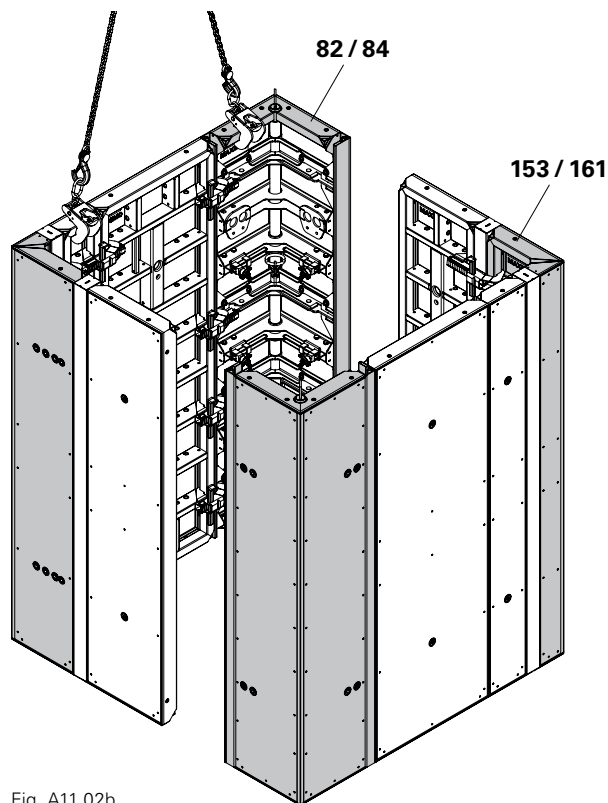


Fig. A11.02b

Shuttering

1. Insert formwork lever into the opening (80.4) and press upwards. (Fig. A11.03b)
→ The tube slides downwards.
2. Push the slider of the positioning waler (80.5) over the profile until there is a flush fit - 4x. (Fig. A11.03 + A11.03a)
3. Tighten wingnut - 4x.
4. Press movable edge strut outwards using the formwork lever.
→ The transition from shaft corner and following panel is flush and tight.



For tightening and loosening, the Ratchet MX 15 can also be used. (Fig. A11.03c)

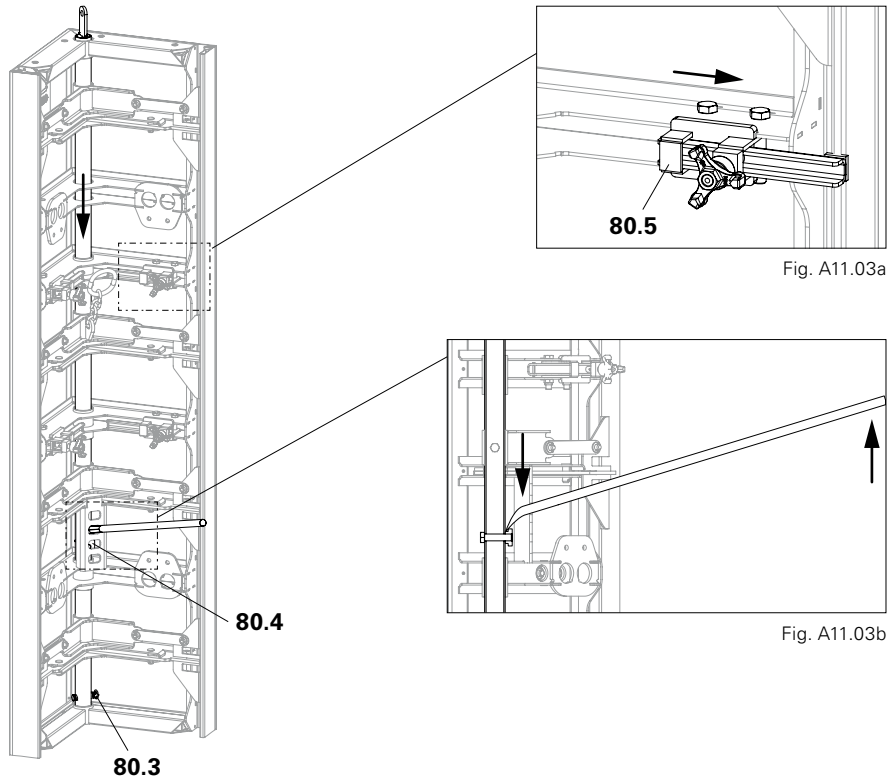


Fig. A11.03

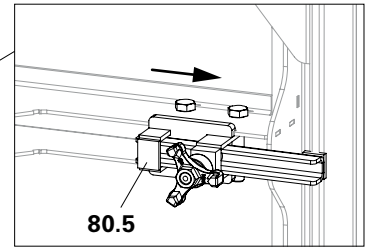


Fig. A11.03a

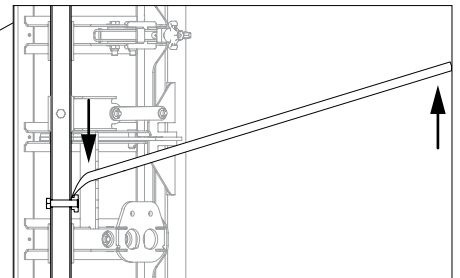


Fig. A11.03b

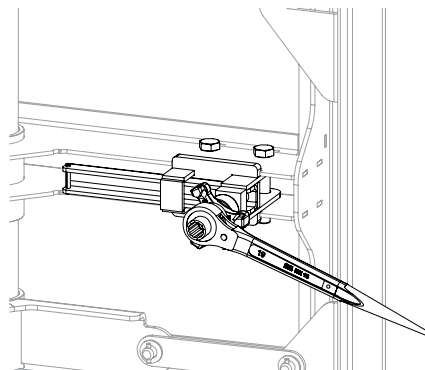


Fig. A11.03c

Striking



Warning

Risk of injury!

- ⇒ Perm. load capacity of 2 t per load-bearing point.
- ⇒ Do not exceed the crane capacity.
- ⇒ Follow Instructions for Use for Lifting Gear Combi MX.

1. Remove tie rods of the closing formwork (1).
2. Loosen wingnut on the positioning waler and push the slider back - 4x. (Fig. A11.04 + A11.04a)
3. Tighten wingnut - 4x.
4. Attach crane lifting gear to the load-bearing point: (Fig. A11.04)
 - with 4 shaft corners, use 4 load-bearing points,
 - with 2 shaft corners, use 2 load-bearing points.
5. Tension crane slings.
6. Press formwork lever downwards. The tube slides upwards and the striking position has been adjusted. (Fig. A11.04 + A11.04b + A11.04c)
7. Pull the complete internal formwork upwards and move.

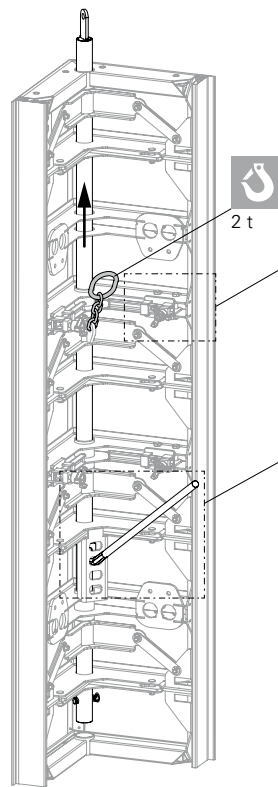


Fig. A11.04

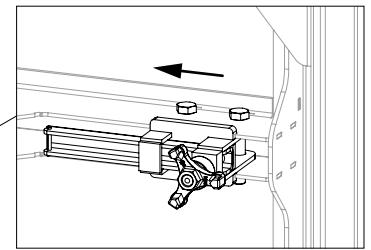


Fig. A11.04a

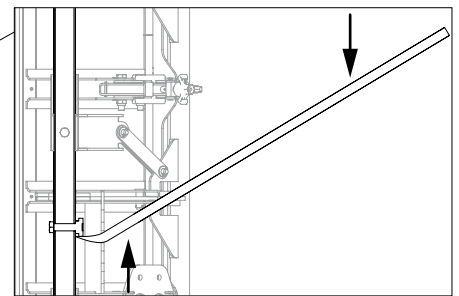


Fig. A11.04b

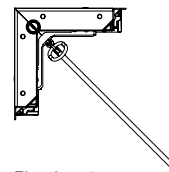


Fig. A11.04c

¹⁾ Closing formwork is the external formwork of the shaft.



There are two possibilities for constructing a shaft:

- With two Shaft Corners MXSE
- With four Shaft Corners MXSE

The option used is project-specifically determined. It depends on:

- the striking clearance,
- the weight per shaft and
- the number of nails for box-outs of individual components, e.g. for windows and doors.

Shaft with two Shaft Corners MXSE

The striking dimensions are reduced by 17.5 mm on each side of the shaft. (Fig. A11.05)



Vertical arrangement of the Alignment Couplers, see:

- Height 270 cm: see Section B12
- Height 330 cm: see Section C13

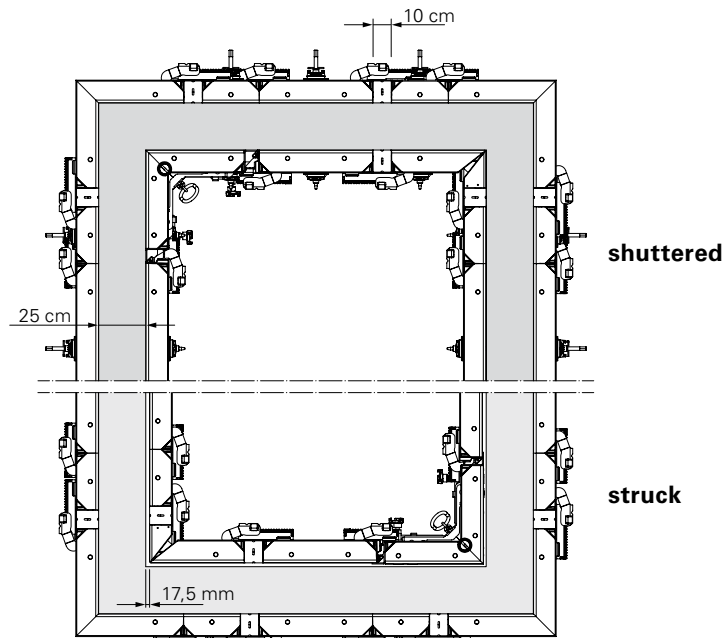


Fig. A11.05

Shaft with four Shaft Corners MXSE

The striking dimensions are reduced by 35 mm on each side of the shaft.
(Fig. A11.06)



Vertical arrangement of the Alignment Couplers, see:

- Height 270 cm: see Section B12
- Height 330 cm: see Section C13

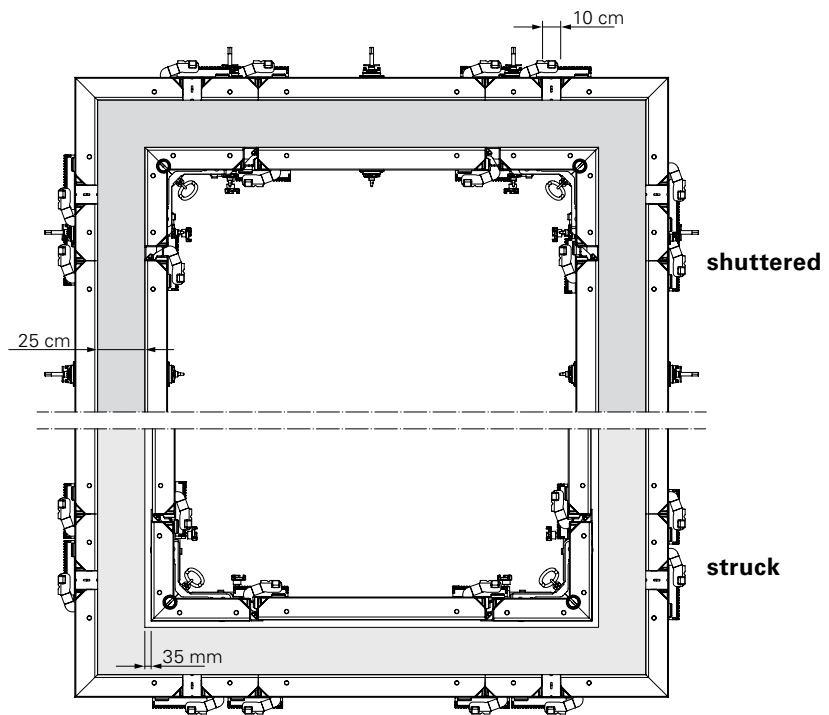


Fig. A11.06

Wall thicknesses



- Dimensions in the illustrations of the wall thicknesses (WD) are given in mm.
- Vertical arrangement of the Alignment Couplers, see:
 - height 270 cm: see Section B12
 - height 330 cm: see Section C13

Wall thickness 150

(Fig. A11.07a + A11.07b)

Shaft with two Shaft Corners MXSE

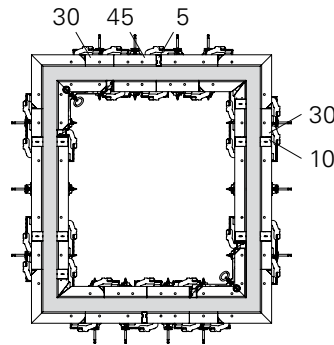


Fig. A11.07a

Shaft with four Shaft Corners MXSE

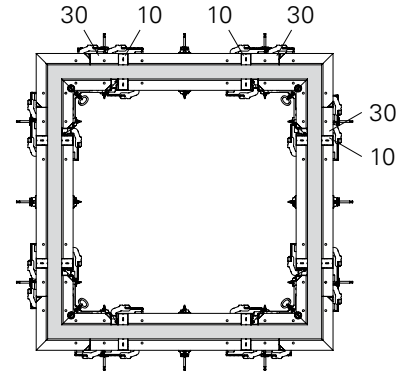


Fig. A11.07b

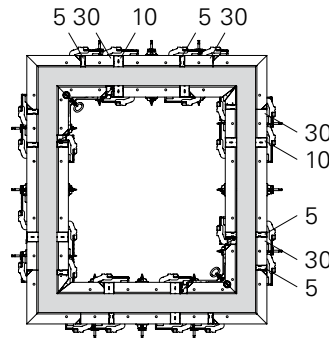


Fig. A11.08a

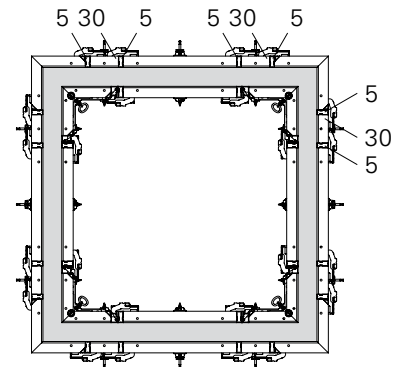


Fig. A11.08b

Wall thickness 200

(Fig. A11.08a + A11.08b)

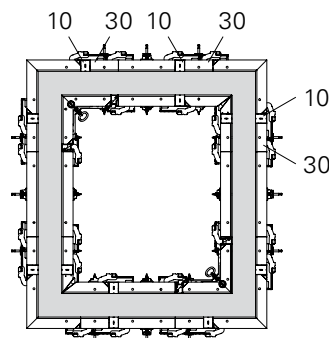


Fig. A11.09a

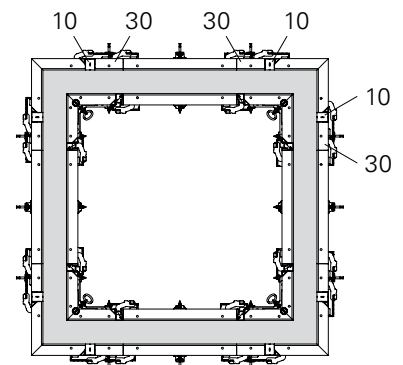


Fig. A11.09b

Wall thickness 250

(Fig. A11.09a + A11.09b)

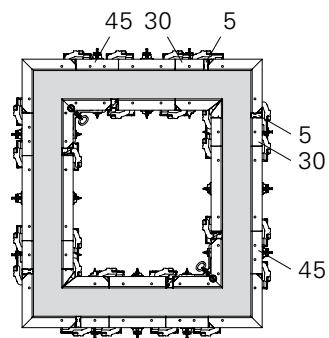


Fig. A11.10a

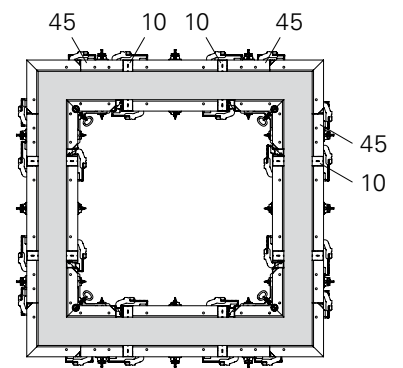


Fig. A11.10b

Wall thickness 300

(Fig. A11.10a + A11.10b)

Height extensions

Shown: height 270 cm

Assembly

1. Remove cotter pins and bolts (80.3). (Fig. A11.11a)
2. Position shaft corners on top of each other. (Fig. A11.11 + A11.11b) Thereby, push the tension strap of the bottom panel into the tube of the top panel.
→ The holes are congruent.
3. Insert bolts (80.3) through the congruent holes and secure with cotter pins. (Fig. A11.11 – A11.11c)
4. Connect shaft corners with two Alignment Couplers BFD (20). (Fig. A11.11c)

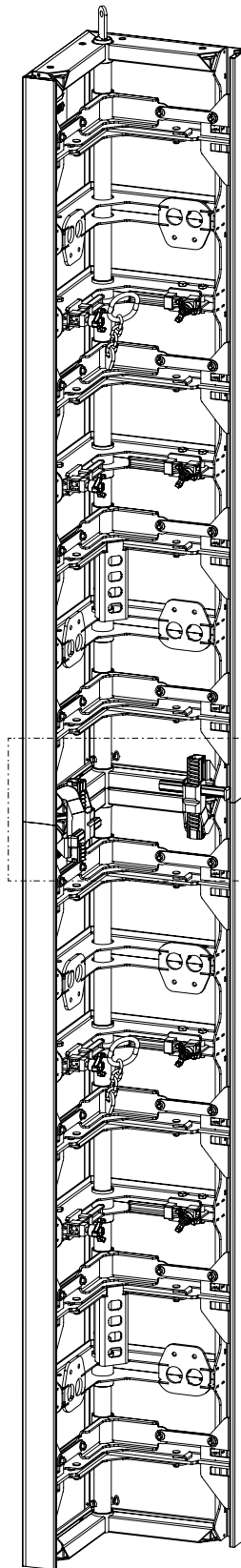


Fig. A11.11

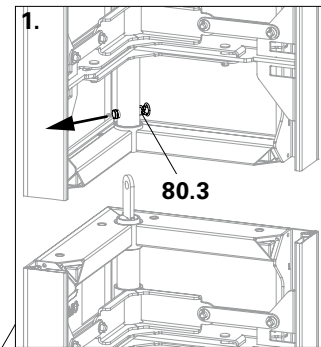


Fig. A11.11a

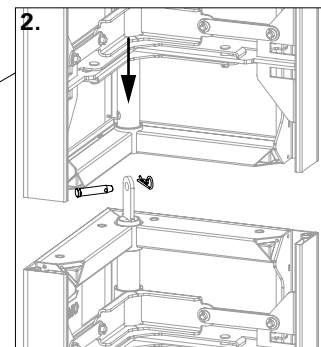


Fig. A11.11b

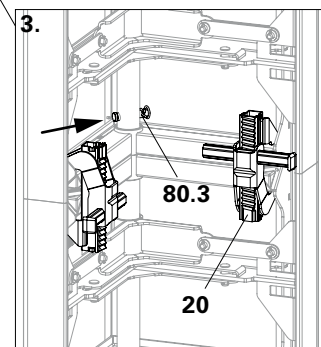


Fig. A11.11c

Obtuse wall connections

Connection with Panel MX 270 x 240.
(Fig. A12.01a)

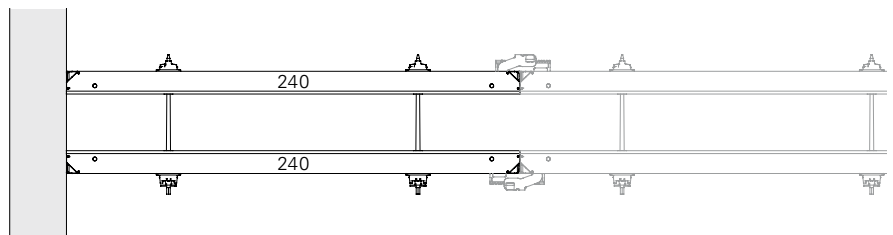


Fig. A12.01a

Connection with Panel MX width > 60.
(Fig. A12.01b)

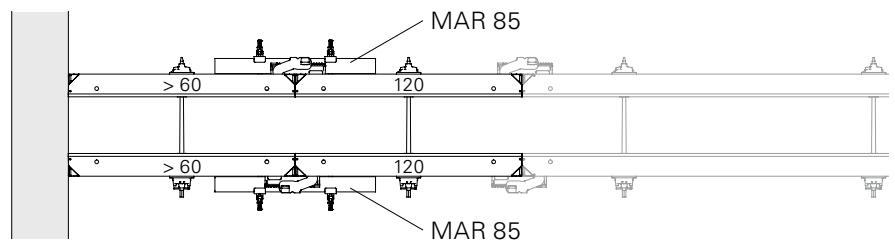


Fig. A12.01b

Connection with Panel MX width ≤ 60.
(Fig. A12.01c)

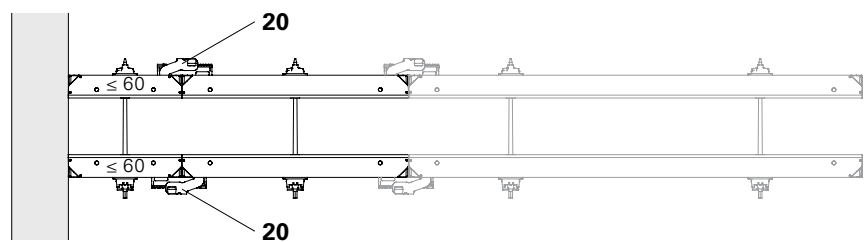


Fig. A12.01c

Vertical wall connections

(Fig. A12.02)



Warning

Risk of injury!

⇒ For vertical wall connections, the Tie MX 15 must be tightly installed (tension and compression-proof) towards the wall connection in the specified order.

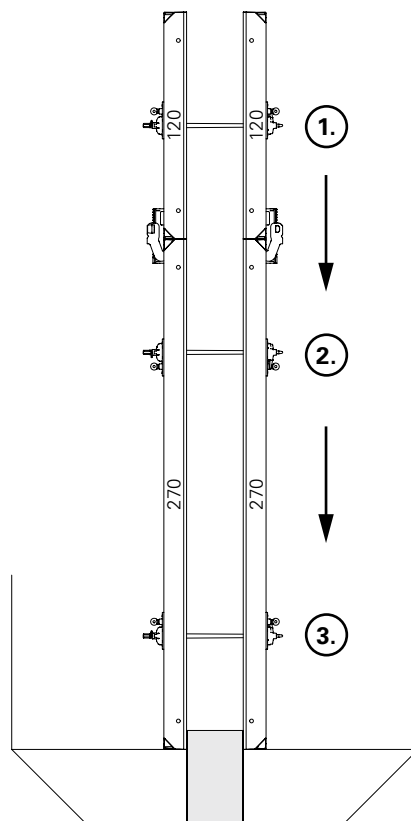


Fig. A12.02

Horizontal wall connections

(Fig. A12.03a + A12.03b)



Warning

Risk of injury!

⇒ For horizontal wall connections, the Tie MX 15 must be tightly installed (tension and compression-proof) towards the wall connection in the specified order.



On the first panel joint, a Compensation Waler MAR 85 (21) must always be mounted in the bottom area.
Exception: Panel B > 120 cm.

Section view (Fig. A12.03c)

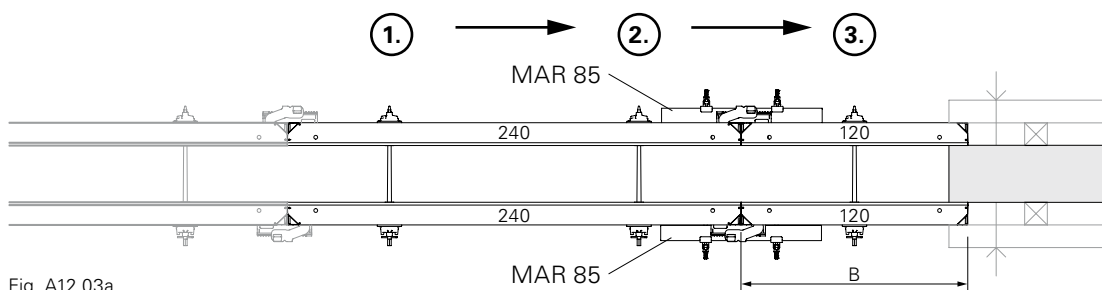


Fig. A12.03a

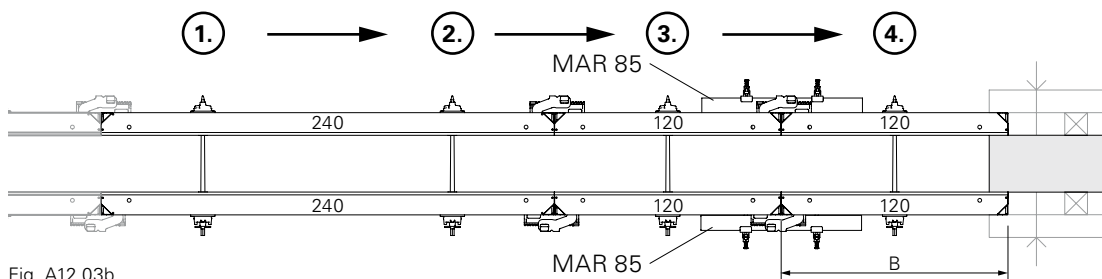


Fig. A12.03b

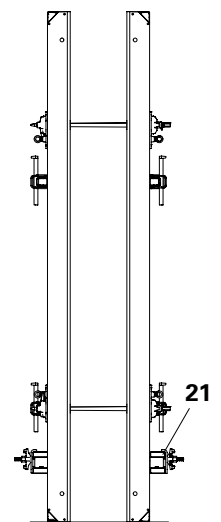


Fig. A12.03c

Installation



When using the Magnet Cone MX 15, the inclined position of the tie is reduced to 2.5°.

Before installing the Magnet Cone MX 15, ensure that

- the Magnet Cones have been completely submerged in a release agent and have been allowed to drain off.
- the contact surfaces of the magnets are clean.

The Magnet Cone MX 15 (42)

- can be used on one or both sides and without a spacer tube.
- is held in position at the tie point with magnets.

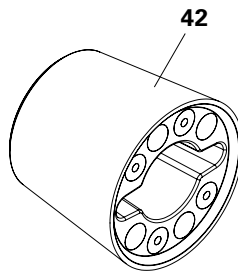


Fig. A13.01

Pos.	Components	Item no.
31	Tie MX 15 acc. to wall thickness	
42	Magnet Cone MX 15	112937
43	Magnet Cone Spanner MX 15 / MX 18	126696
43.1	Spanner lug	
43.2	Retaining lug	

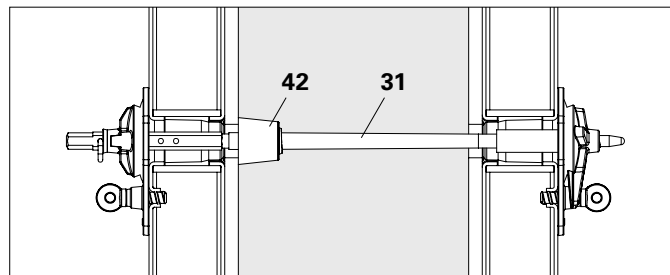


Fig. A13.02a

Magnet Cone MX 15

(Fig. A13.01)

Installation on one side

(Fig. A13.02a)

Installation on both sides

(Fig. A13.02b)

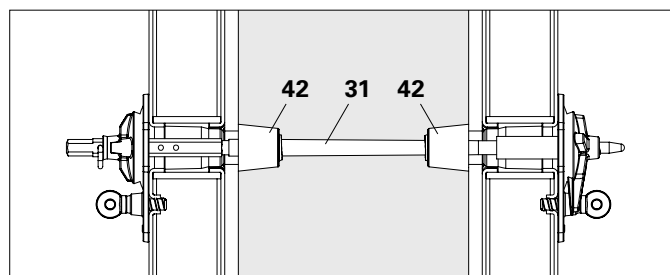


Fig. A13.02b

Magnet Cone Spanner MX 15 / MX 18

The Magnet Cone Spanner MX 15/MX 18 (43) is used for dismantling Magnet Cones. (Fig. A13.03)

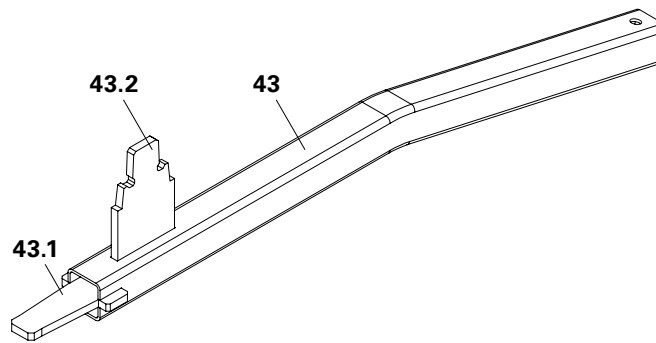


Fig. A13.03

Removal



Remove concrete slurry in the Magnet Cones - shortly after striking.

1. Insert spanner lug (43.1) as straight as possible and turn when in the hole.
→ Hole is cleaned.
2. Insert spanner lug (43.1) into the guide groove of the Magnet Cone from the right, and clean the slot. (Fig. A13.04a)
3. Insert spanner lug (43.1) into the guide groove of the Magnet Cone from the left, and clean the slot. (Fig. A13.04b)
→ Hole and guide grooves of the Magnet Cone are free of concrete slurry.
4. Insert retaining lugs (43.2) into the cleaned openings. (Fig. A13.04c)
5. Turn the Magnet Cone Spanner. (Fig. A13.04d)
→ Magnet Cone MX 15 is screwed out.

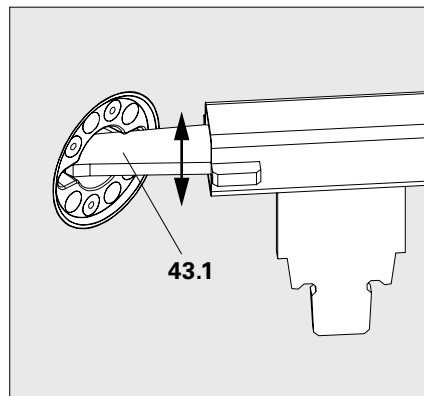


Fig. A13.04a

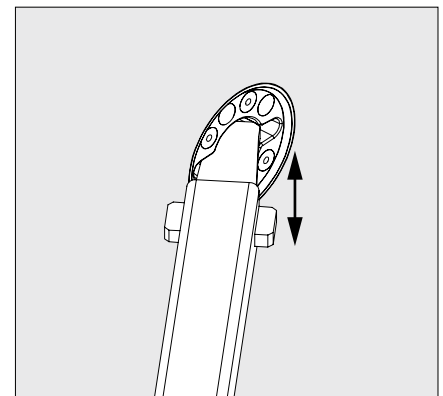


Fig. A13.04b

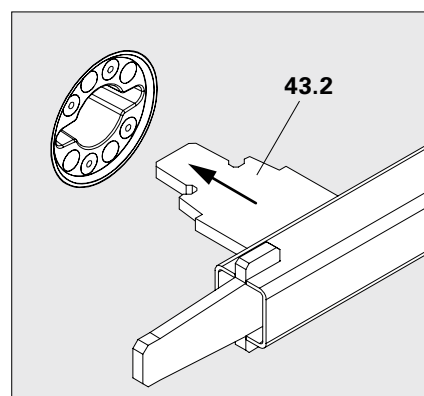


Fig. A13.04c

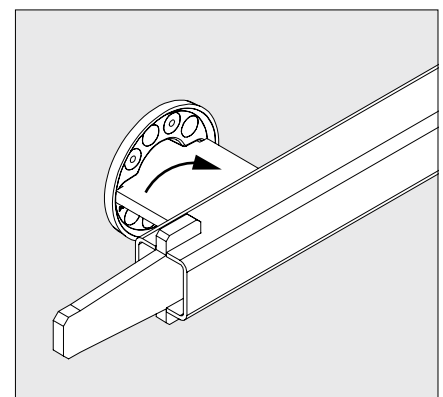


Fig. A13.04d

Closing the cone openings

PERI "DK/SK System" Tie Technology can be used for special requirements such as architectural concrete or water-proof walls - see "PERI Tie Technology" brochure.



- Observe User Information for Concrete Cones with Sealing Compound-3.
- Follow the Safety Data Sheet for the sealing compound.

Assembly

1. Spread prepared sealing compound or Repoxal on front conical part of the Concrete Cone.
2. Insert Concrete Cone into the tie point.
→ Tie point is closed.

Examples

- Smooth surface with DK Concrete Cone UNI 58/52, Item no. 031643.
 - Sealing Compound-3, Item no. 131709.
- (Fig. A13.05)

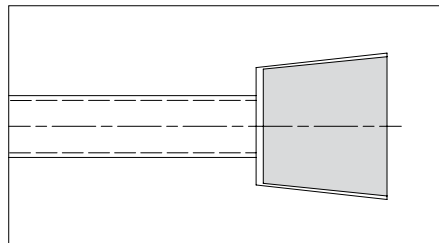


Fig. A13.05

- Recessed surface with DK Concrete Cone DW 15/58-30, Item No. 031642.
 - Repoxal, Item no. 031550.
- (Fig. A13.06)

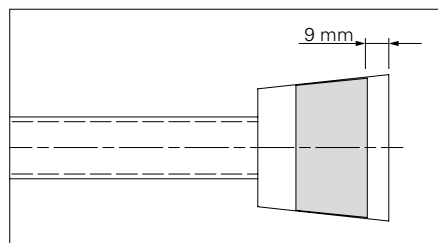


Fig. A13.06

- Shadow joint with DK Concrete Cone Architectural Concrete/01 DW 15/58-52, Item no. 031641.
 - Sealing Compound-3, Item no. 131709.
- (Fig. A13.07)

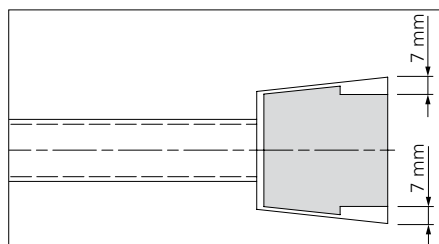


Fig. A13.07

Removing the sealing

Pos.	Components	Item no.
10	Panel MX Height x width according to size	
10.1	Tie point with sealing	
96	Removable Tool MX Sealing	125337
96.1	Extraction head	
96.2	Extractor bell	

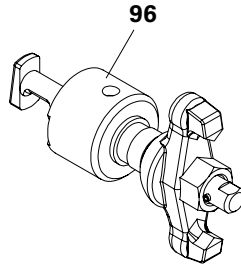


Fig. A14.01a

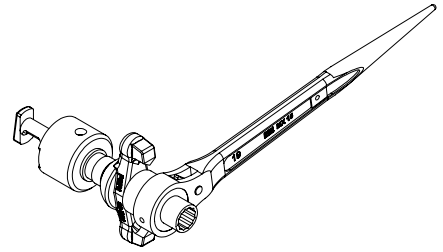


Fig. A14.01b

Preparing the Removable Tool MX

Turn back the Removable Tool MX (96).
(Fig. A14.01a)

Starting position on the panel

Replacement of Sealing MX 15 or modification to Sealing MX 18 (10.1).
(Fig. A14.02)

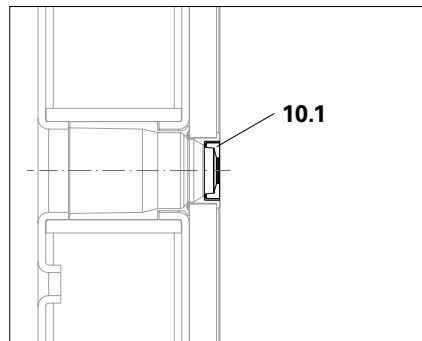


Fig. A14.02

Using the Removable Tool MX

1. Screw in the extraction head (96.1) with the thick end at an angle into the sealing until the extraction head is positioned inside the sealing. (Fig. A14.03a + A14.03b)
2. Turn the Removable Tool MX towards the panel until the extractor bell (96.2) rests against it. (Fig. A14.04a)
3. Secure the extractor bell and continue turning until the sealing is released.
4. Screw out the extraction head from the sealing. (Fig. A14.04b)

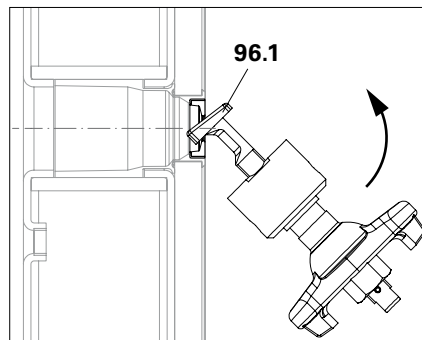


Fig. A14.03a

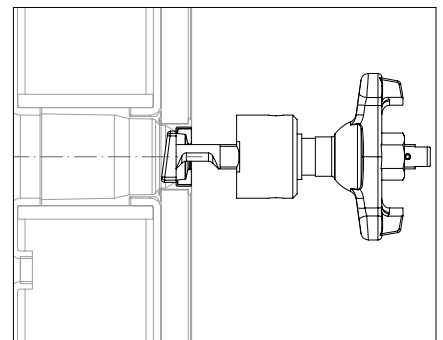


Fig. A14.03b



For loosening, the Ratchet MX 15 can also be used. (Fig. A14.01b)

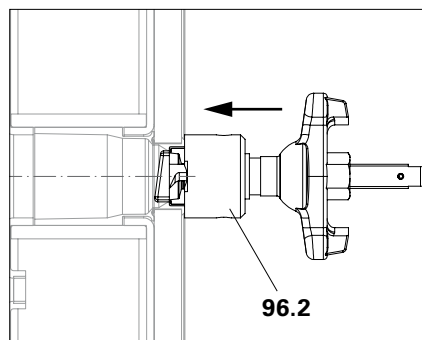


Fig. A14.04a

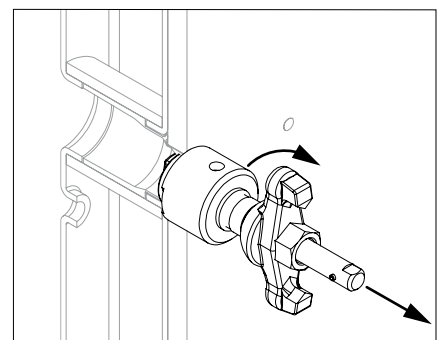


Fig. A14.04b

Inserting the sealing

Inner side of panel

1. Place new sealing on the opening.
(Fig. A14.05a)
2. Install sealing using hammer and plate until flush fit is achieved.
(Fig. A14.05b)
→ The sealing has now been replaced.
(Fig. A14.06)

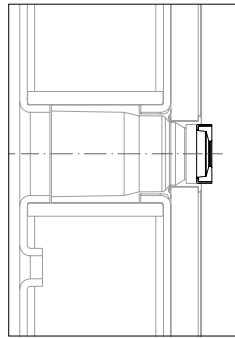


Fig. A14.05a

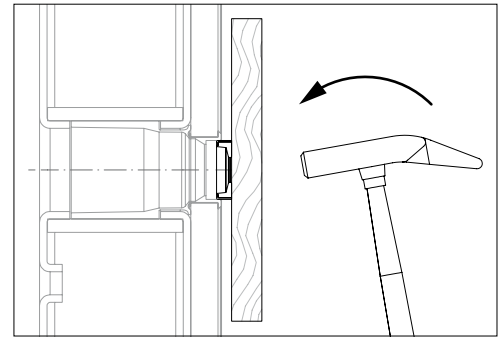


Fig. A14.05b

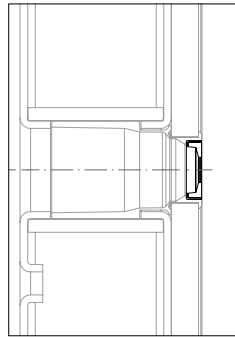


Fig. A14.06

Wall thicknesses 15 – 40 cm Outside Corner 270 x 45



Perm. fresh concrete pressure: 60 kN/m²

Pos. Components

- 20** Alignment Coupler BFD
- 100** Multi Panel MXM 270 x 60
- 101** Panel MX 270 x 30
- 102** Panel MX 270 x 45
- 106** Panel MX 270 x 240
- 140** Wall Thickness Compensator WDA MX 270 x width or filler timber
- 151** Outside Corner MXA 270 x 45
- 153** Inside Corner MXI 270 x 50/20

Examples

- WD* 15: Fig. B1.01
- WD 17.5: Fig. B1.02
- WD 20: Fig. B1.03
- WD 24/25: Fig. B1.04
- WD 30: Fig. B1.05
- WD 35/36: Fig. B1.06
- WD 40: Fig. B1.07

Compensations

- WD 25 + 40: without compensation
- WD 15 + 17.5: internal and external compensation
- WD 20 + 24: internal compensation
- WD 30 + 35/36: external compensation

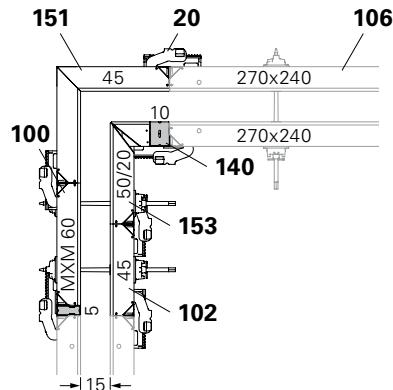


Fig. B1.01

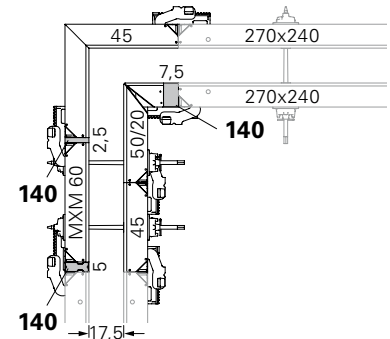


Fig. B1.02

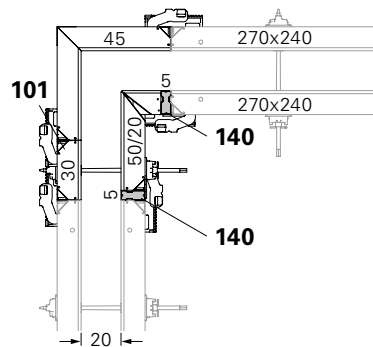


Fig. B1.03

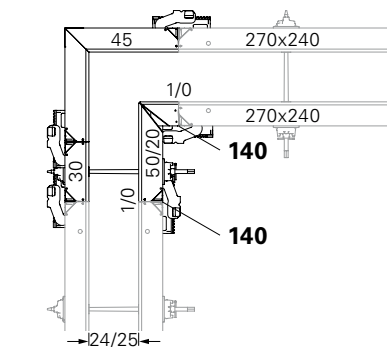


Fig. B1.04

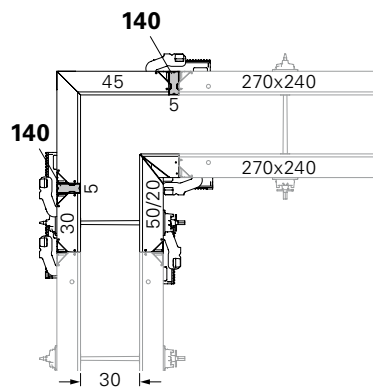


Fig. B1.05

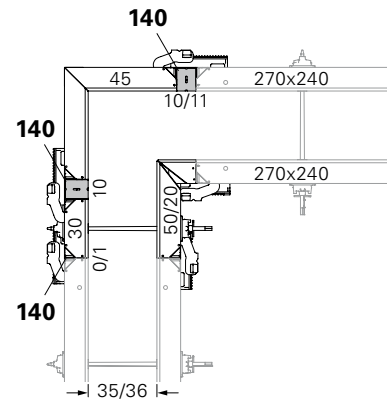


Fig. B1.06



Max. panel width between corner and subsequent panel is 45 cm – Panel MX 270 x 45 (102). (Fig. B1.08)

*WD = wall thickness



Fig. B1.07

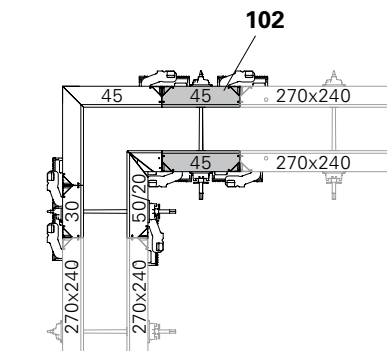


Fig. B1.08

Arrangement of the Alignment Couplers

Valid for wall thicknesses 15 – 40 cm

View of Inside Corner MXI 270 x 50/20
(Fig. B1.09)

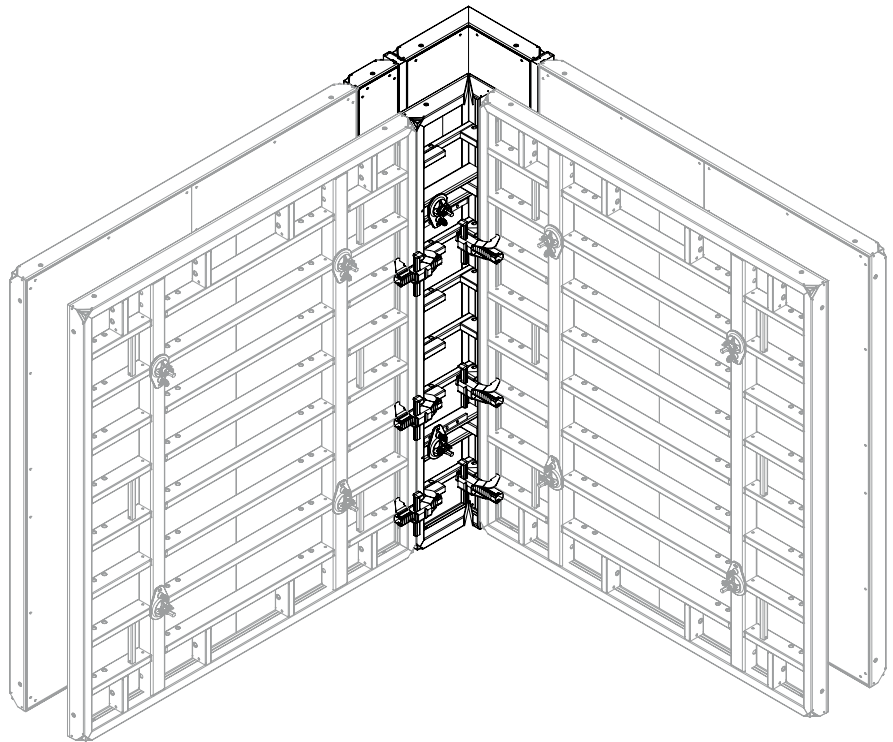


Fig. B1.09

View of Outside Corner MXA 270 x 45
(Fig. B1.10)

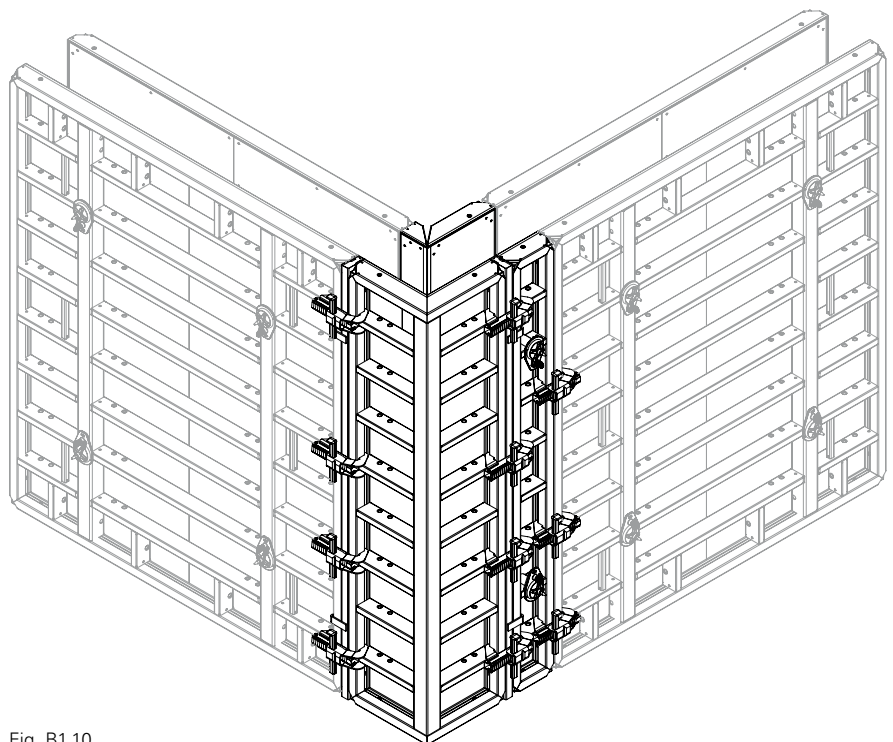


Fig. B1.10

Wall thickness 60 cm
Outside Corner 270 x 45



Perm. fresh concrete pressure: 60 kN/m²

Pos. Components

- 20** Alignment Coupler BFD
- 21** Compensation Waler MAR 85-3
- 22** Compensation Waler MAR 170-3
- 23** Wingnut Pivot Plate DW 15
- 25** Tie Rod DW 15
- 26** Spacer Tube Rough 22
- 100** Multi Panel MXM 270 x 60
- 101** Panel MX 270 x 30
- 140** Wall Thickness Compensator WDA MX 270 x width
- 151** Outside Corner MXA 270 x 45
- 153** Inside Corner MXI 270 x 50/20
- 249** Cone MX DR 22/2

Example

View from the top (Fig. B1.11 + B1.11a)

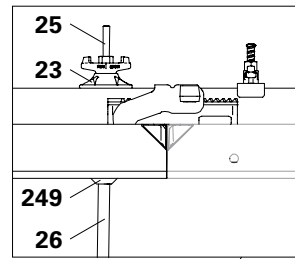


Fig. B1.11a

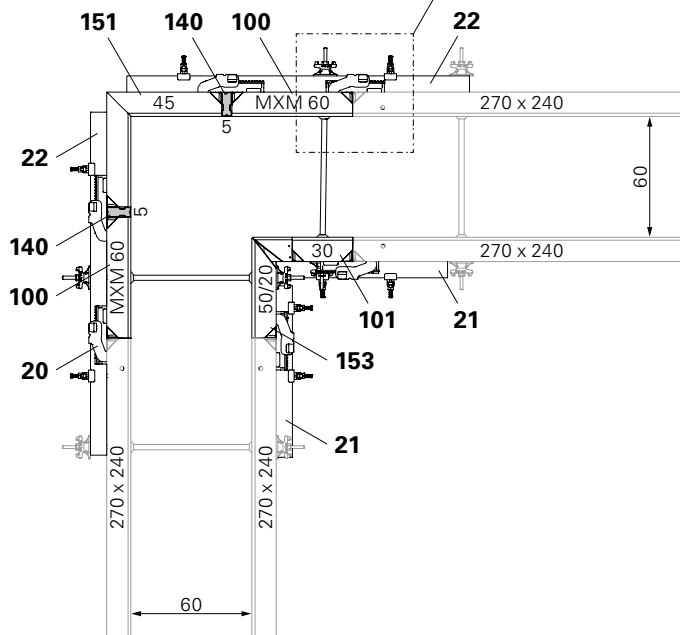


Fig. B1.11

Arrangement of the Alignment Couplers and Steel Walers

View of Inside Corner MXI 270 x 50/20
(Fig. B1.12)

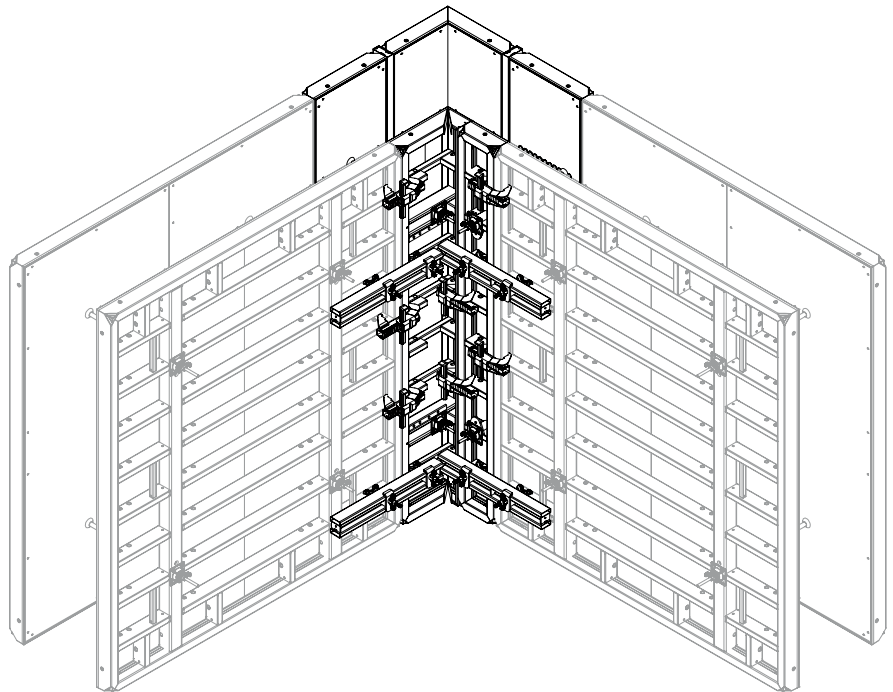


Fig. B1.12

View of Outside Corner MXA 270 x 45
(Fig. B1.13)

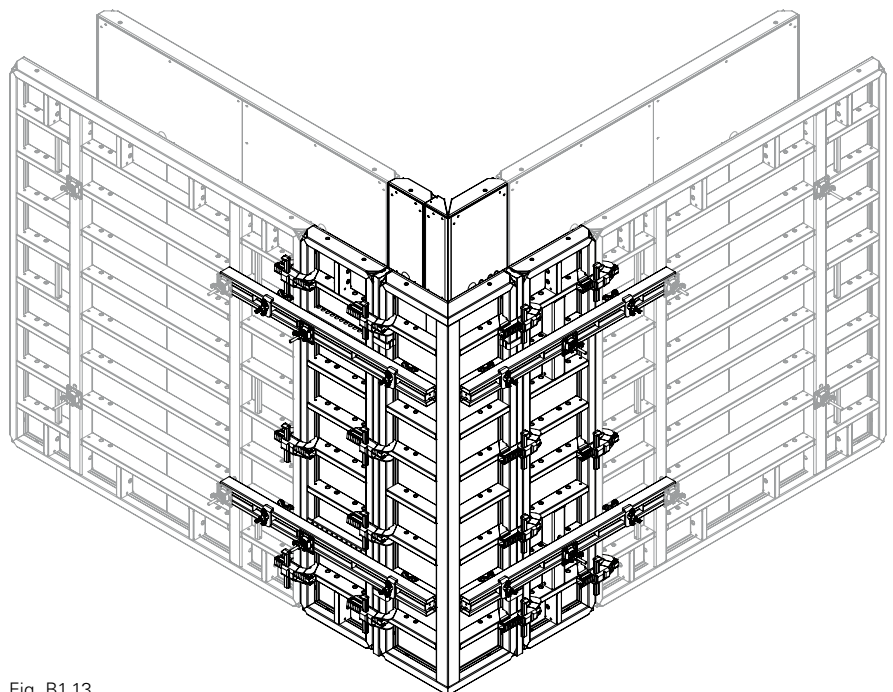


Fig. B1.13

Wall thickness 80 cm

Outside Corner MXA 270 x 45



Perm. fresh concrete pressure: 60 kN/m²

Pos. Components

- 19** Waler Stop
- 20** Alignment Coupler BFD
- 23** Wingnut Pivot Plate DW 15
- 24** Hook Tie DW 15, L = 400
- 25** Tie Rod DW 15
- 29** Steel Waler Universal SRU U120, L = 2.47 m
- 36** Tie Rod DW 20
- 37** Spacer Tube Rough 28
- 38** DK Sealing Cone DW 20/55
- 39** Wingnut Pivot Plate DW 20
- 44** Wingnut DW 15
- 49** Tie Yoke SW
- 101** Panel MX 270 x 30
- 103** Panel MX 270 x 60
- 140** Wall Thickness Compensator WDA MX 270 x width or filler timber
- 151** Outside Corner MXA 270 x 45
- 153** Inside Corner MXI 270 x 50/20

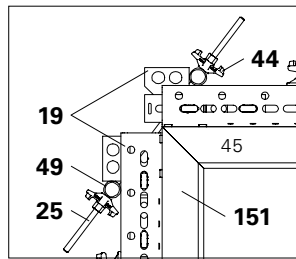


Fig. B1.14a

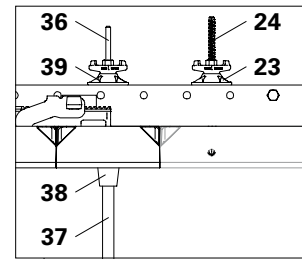


Fig. B1.14b

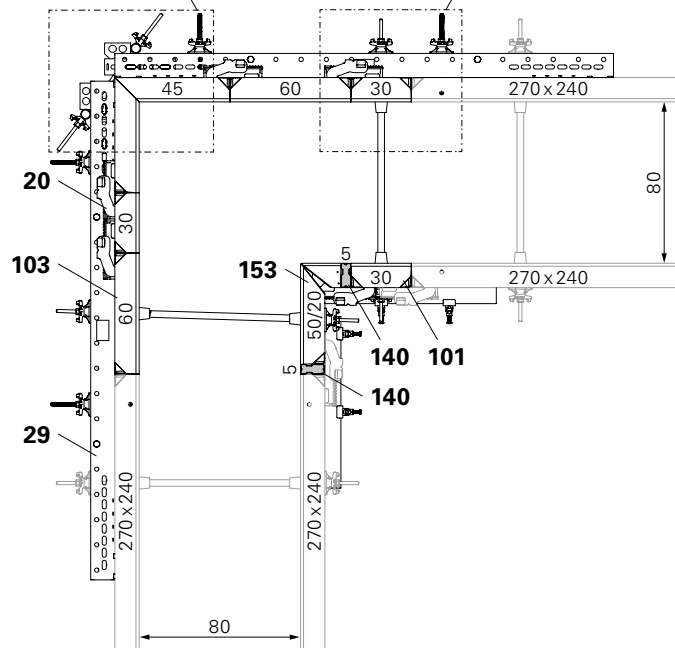


Fig. B1.14

Example

View from above
(Fig. B1.14 + B1.14a + B1.14b)

Arrangement of the Alignment Couplers and Steel Walers

View of Inside Corner MXI 270 x 50/20
(Fig. B1.15)

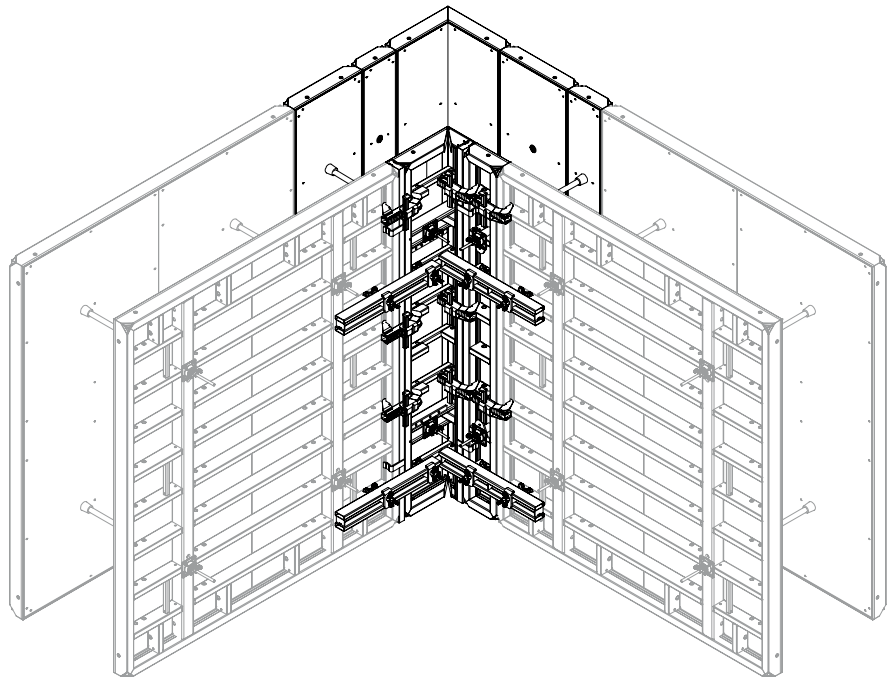


Fig. B1.15

View of Outside Corner MXA 270 x 45
(Fig. B1.16)

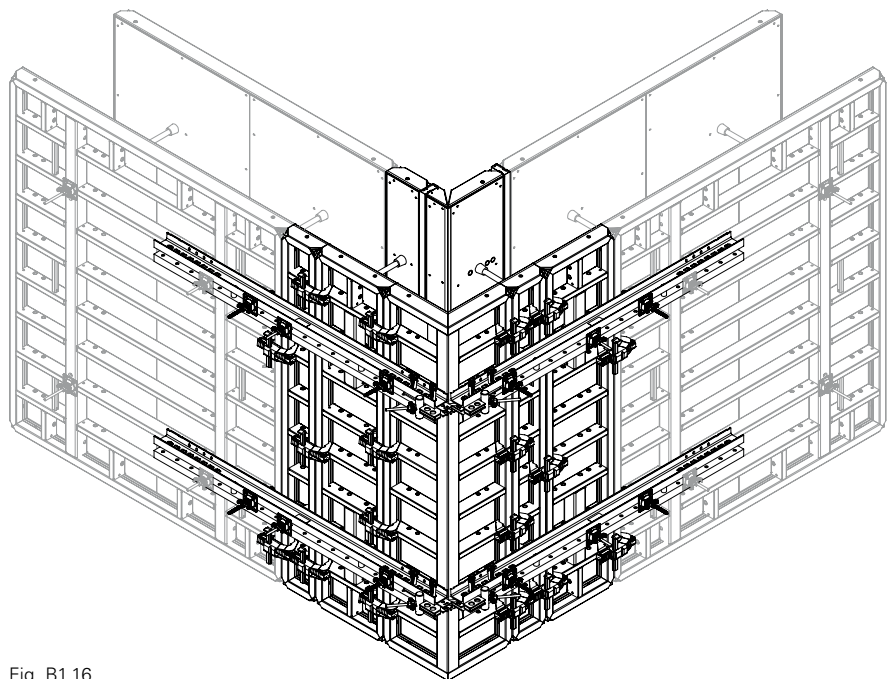


Fig. B1.16

Wall thicknesses 15 – 30 cm Outside Corner MXA 270 x 35



Perm. fresh concrete pressure: 60 kN/m²

Pos. Components

- 20** Alignment Coupler BFD
- 101** Panel MX 270 x 30
- 102** Panel MX 270 x 45
- 140** Wall Thickness Compensator WDA
MX 270 x width or filler timber
- 150** Outside Corner MXA 270 x 35
- 152** Inside Corner MXI 270 x 60

Examples

- WD 15: Fig. B2.01
- WD 17.5: Fig. B2.02
- WD 20: Fig. B2.03
- WD 24/25: Fig. B2.04
- WD 30: Fig. B2.05

Compensations

- Wall thickness 15 + 17.5 cm:
external compensation
- Wall thickness 20 cm: without
compensation
- Wall thickness 24/25 + 30 cm:
external compensation

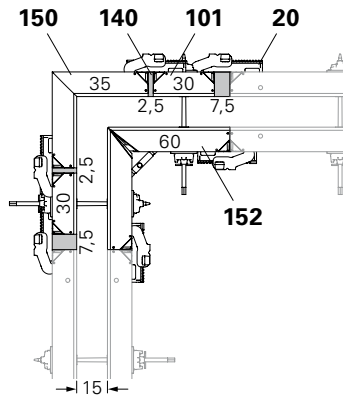


Fig. B2.01

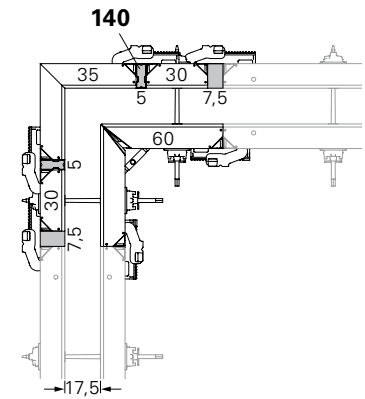


Fig. B2.02

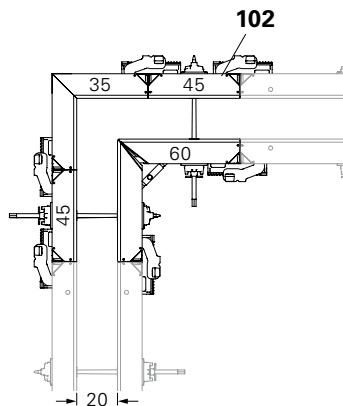


Fig. B2.03

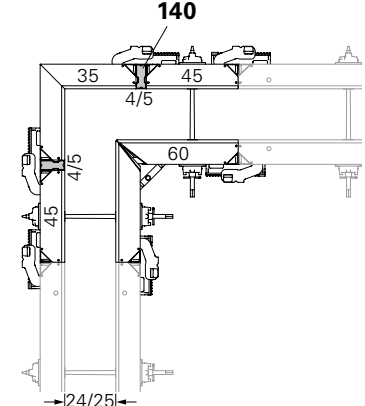


Fig. B2.04

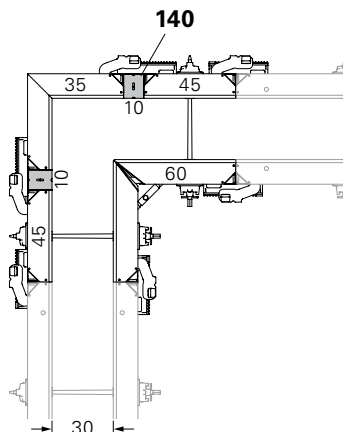


Fig. B2.05

Wall thicknesses 30 – 40 cm Outside Corner MXA 270 x 45



Perm. fresh concrete pressure: 60 kN/m²

Pos. Components

- 20** Alignment Coupler BFD
- 102** Panel MX 270 x 45
- 140** Wall Thickness Compensator WDA
MX 270 x width or filler timber
- 151** Outside Corner MXA 270 x 45
- 152** Inside Corner MXI 270 x 60

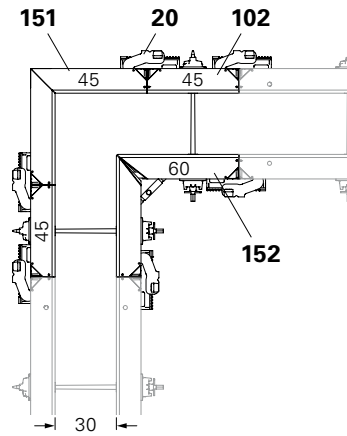


Fig. B2.06

Examples

- Wall thickness 30: Fig. B2.06
- Wall thickness 35/36: Fig. B2.07
- Wall thickness 40: Fig. B2.08

Compensations

- Wall thickness 30 cm: without compensation
- Wall thickness 35/36 + 40 cm: external compensation

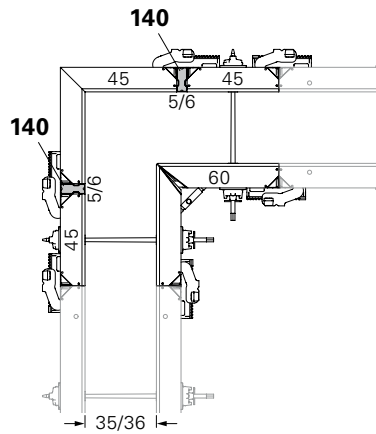


Fig. B2.07

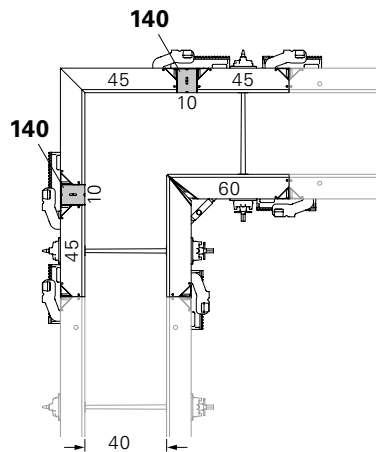


Fig. B2.08

Arrangement of the Alignment Couplers and Steel Walers

Valid for wall thicknesses 15 - 40 cm

View of Inside Corner MXI 270 x 60
(Fig. B2.09)

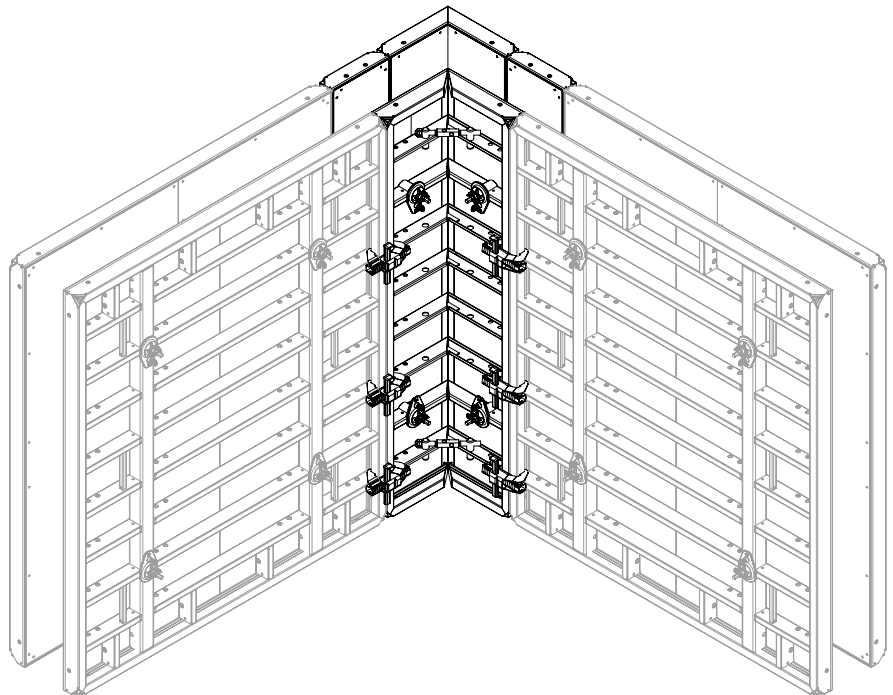


Fig. B2.09

View of Outside Corner MXA 270 x 45 /
270 x 35 (Fig. B2.10)

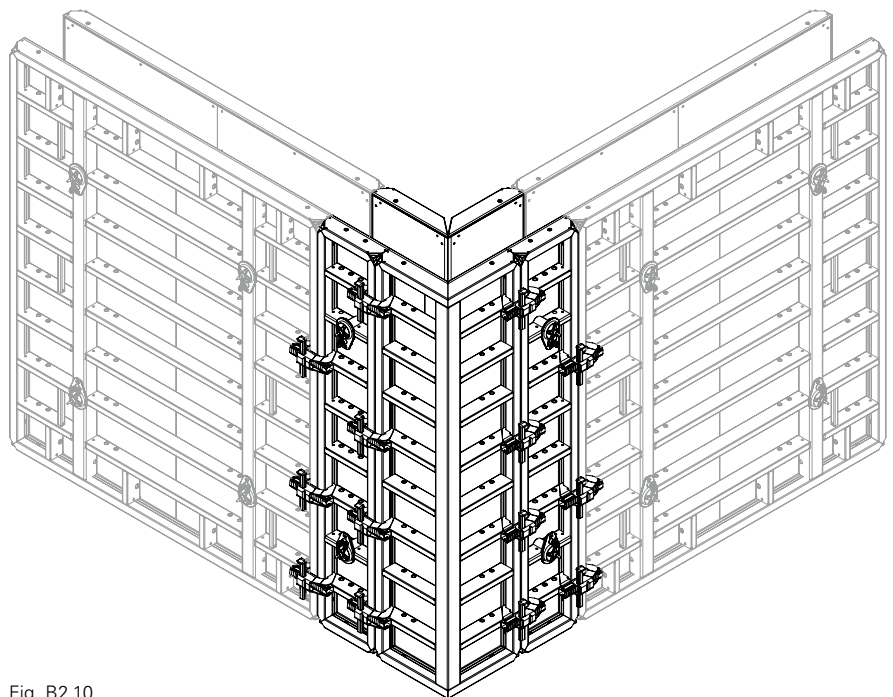


Fig. B2.10

B2 90° Corners with Inside Corner MXI 270 x 60

Wall thickness 60 cm

Outside Corner MXA 270 x 45



Perm. fresh concrete pressure: 60 kN/m²

Pos. Components

- 20** Alignment Coupler BFD
- 22** Compensation Waler MAR 170-3
- 23** Wingnut Pivot Plate DW 15
- 25** Tie Rod DW 15
- 26** Spacer Tube Rough 22
- 101** Panel MX 270 x 30
- 102** Panel MX 270 x 45
- 151** Outside Corner MXA 270 x 45
- 152** Inside Corner MXI 270 x 60
- 249** Cone MX DR 22/2

Example

View from the top (Fig. B2.11 + B2.11a)

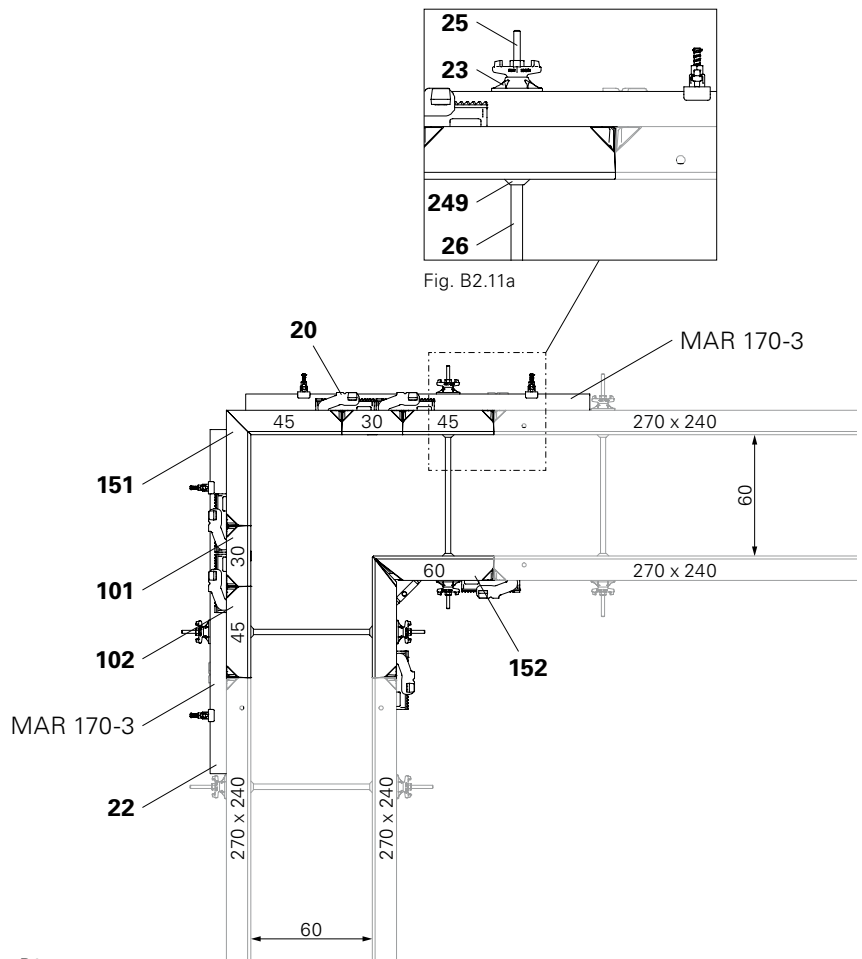


Fig. B2.11

Arrangement of the Alignment Couplers and Steel Walers

View of Inside Corner MXI 270 x 60
(Fig. B2.12)

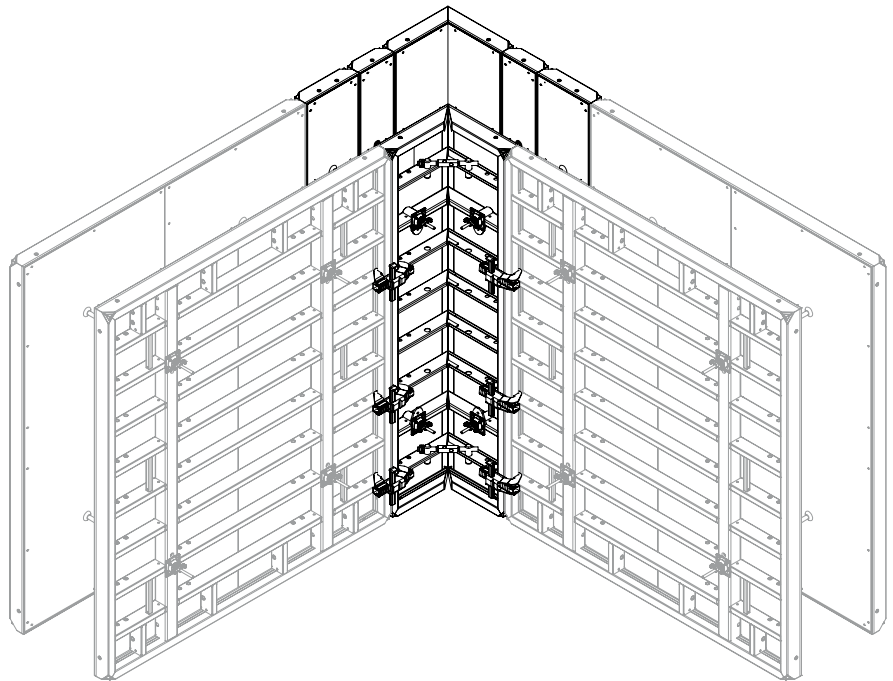


Fig. B2.12

View of Outside Corner MXA 270 x 45
(Fig. B2.13)

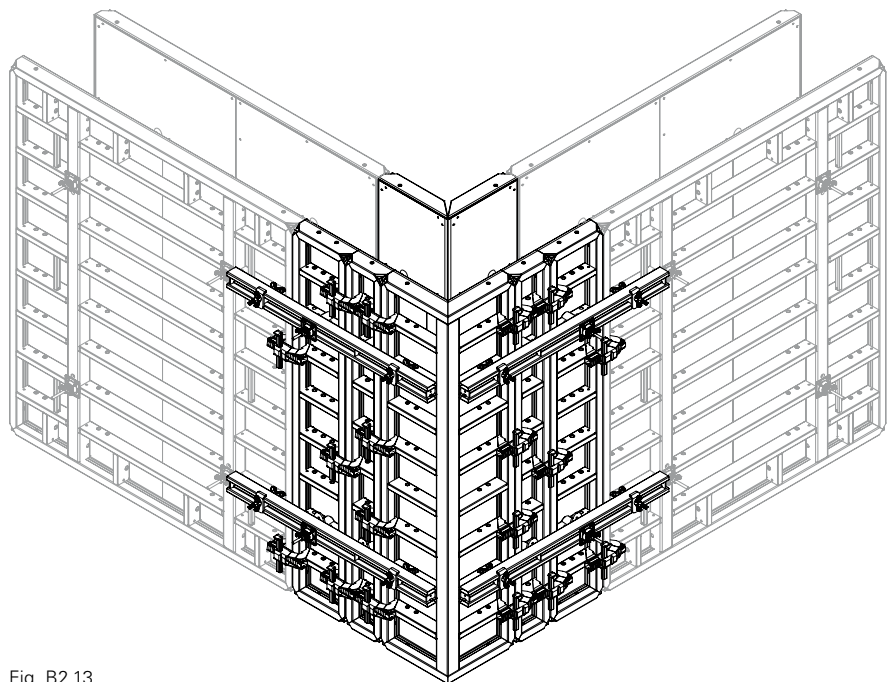


Fig. B2.13

Wall thickness 80 cm

Outside Corner MXA 270 x 45



Perm. fresh concrete pressure: 60 kN/m²

Pos. Components

- 19** Waler Stop
- 20** Alignment Coupler BFD
- 23** Wingnut Pivot Plate DW 15
- 24** Hook Tie DW 15, L = 400
- 25** Tie Rod DW 15
- 29** Steel Waler Universal SRU U120, L = 2.47 m
- 36** Tie Rod DW 20
- 37** Spacer Tube Rough 28
- 38** DK Sealing Cone DW 20/55
- 39** Wingnut Pivot Plate DW 20
- 44** Wingnut DW 15
- 49** Tie Yoke SW
- 102** Panel MX 270 x 45
- 140** Wall Thickness Compensator WDA MX 270 x width or filler timber
- 151** Outside Corner MXA 270 x 45
- 152** Inside Corner MXI 270 x 60

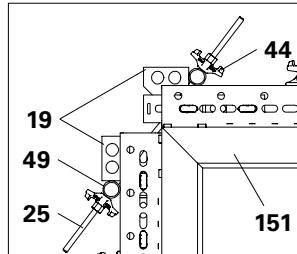


Fig. B2.14a

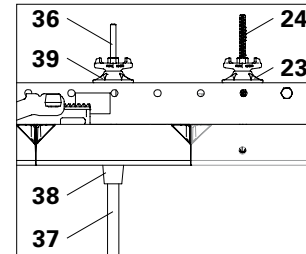


Fig. B2.14b

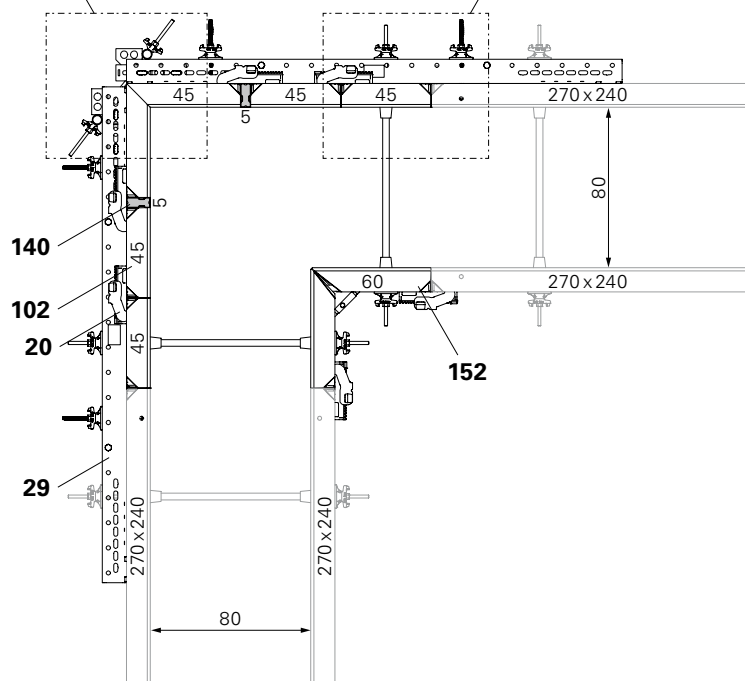


Fig. B2.14

Example

View from above
(Fig. B2.14 + B2.14a + B2.14b)

Arrangement of the Alignment Couplers and Steel Walers

View of Inside Corner MXI 270 x 60
(Fig. B2.15)

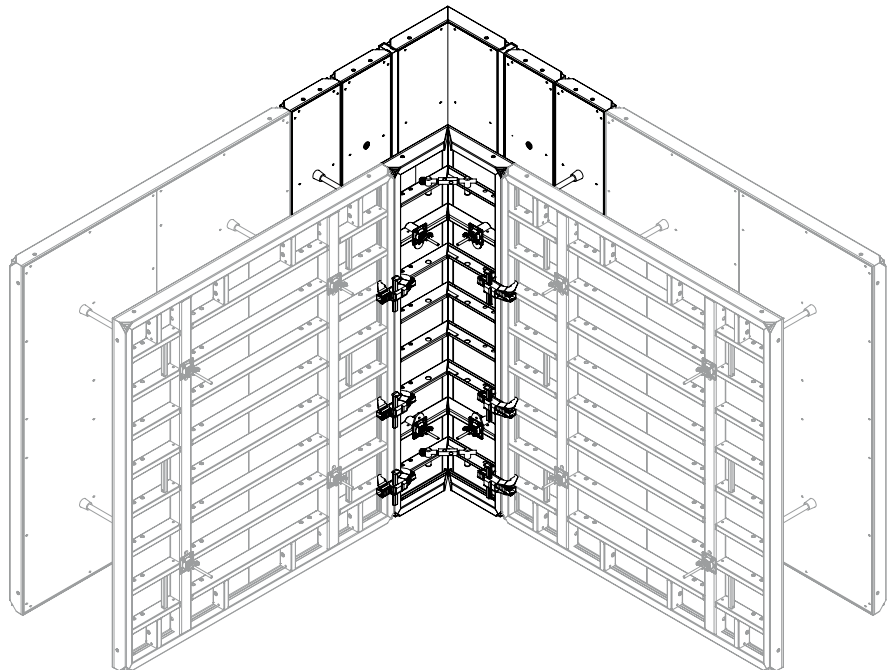


Fig. B2.15

View of Outside Corner MXA 270 x 45
(Fig. B2.16)

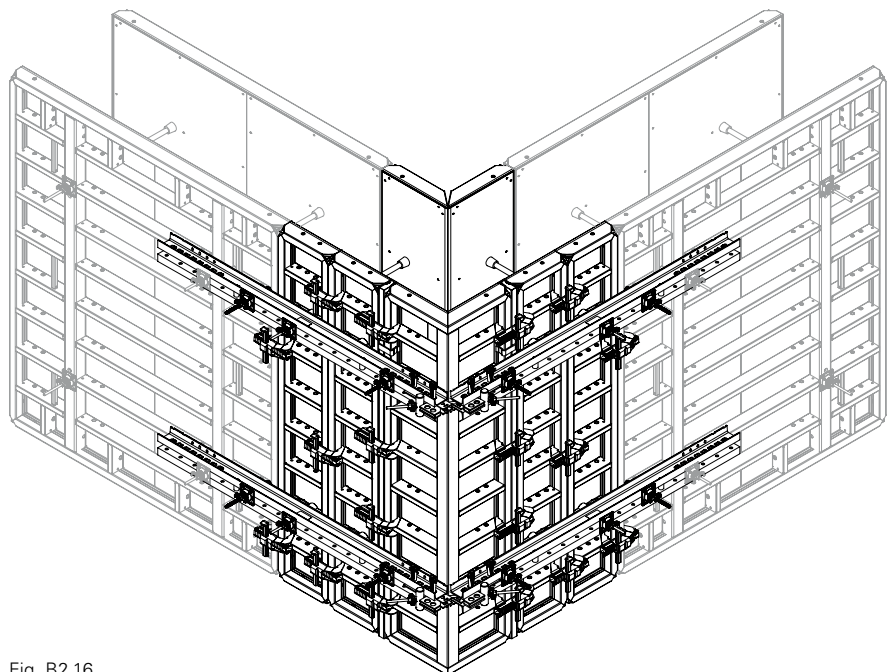


Fig. B2.16

B3 Panel connections following 90° corners

Panel connections

For panels with widths $b \leq 120$ following 90° corners, these must be strengthened at the next panel joint by means of a Compensation Waler MAR 85 (21).

With extensions, a second Compensation Waler MAR 85 (21) is required on the panel joint (shown as a dotted line). (Fig. B3.02 + B3.03)

Pos.	Components	Item no.
20	Alignment Coupler BFD 023500	
21	Compensation Waler MAR 85-3	124941

Example

View from above (Fig. B3.01)

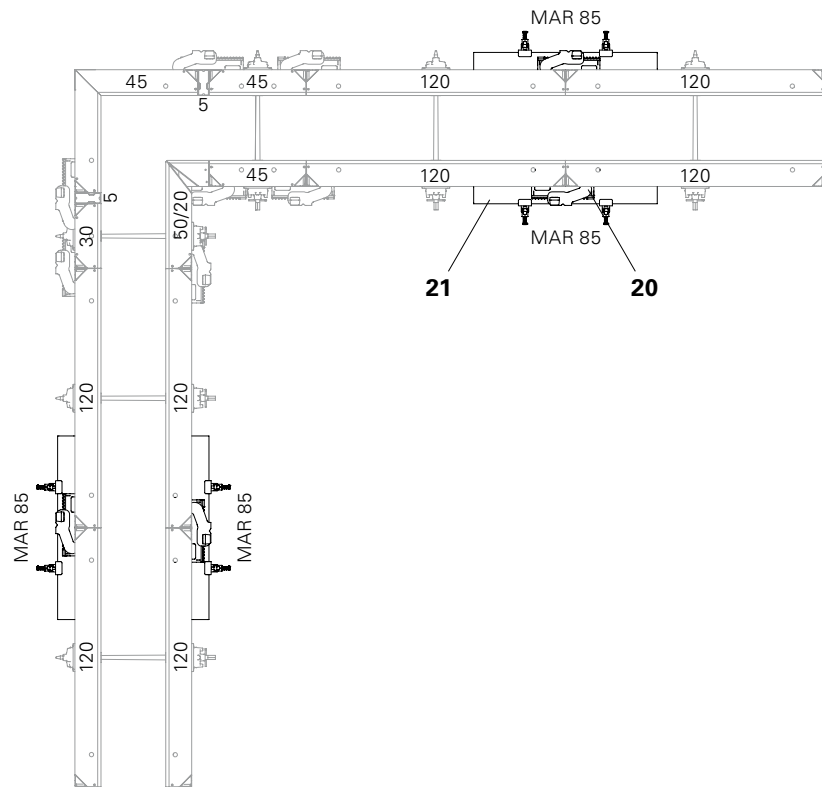


Fig. B3.01

B3 Panel connections following 90° corners

Arrangement of the Alignment Couplers and Steel Walers

View of Inside Corner MXI 270 x 50/20
(Fig. B3.02)

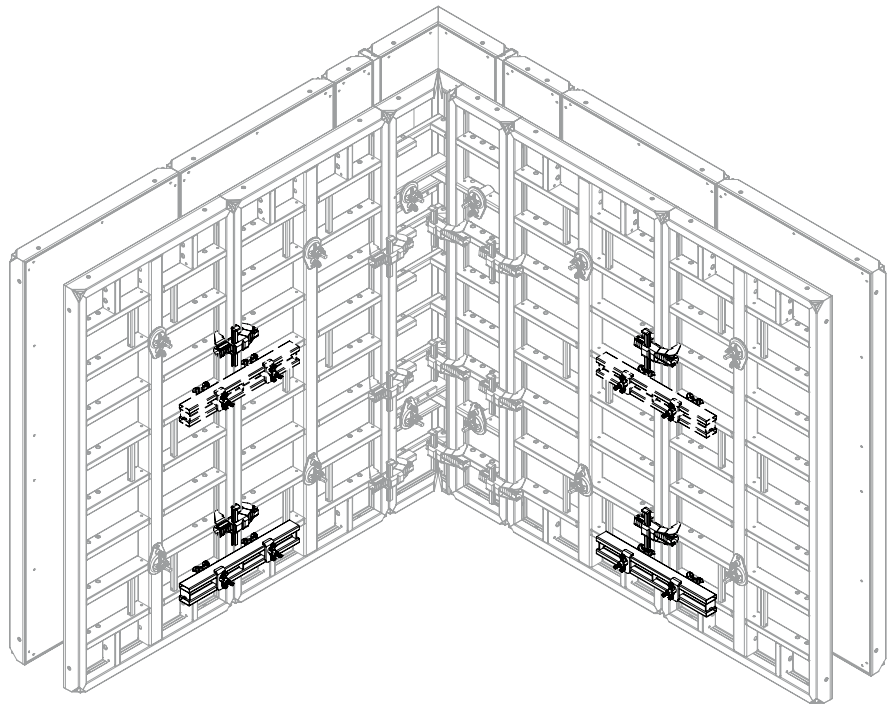


Fig. B3.02

View of Outside Corner MXA 270 x 45
(Fig. B3.03)

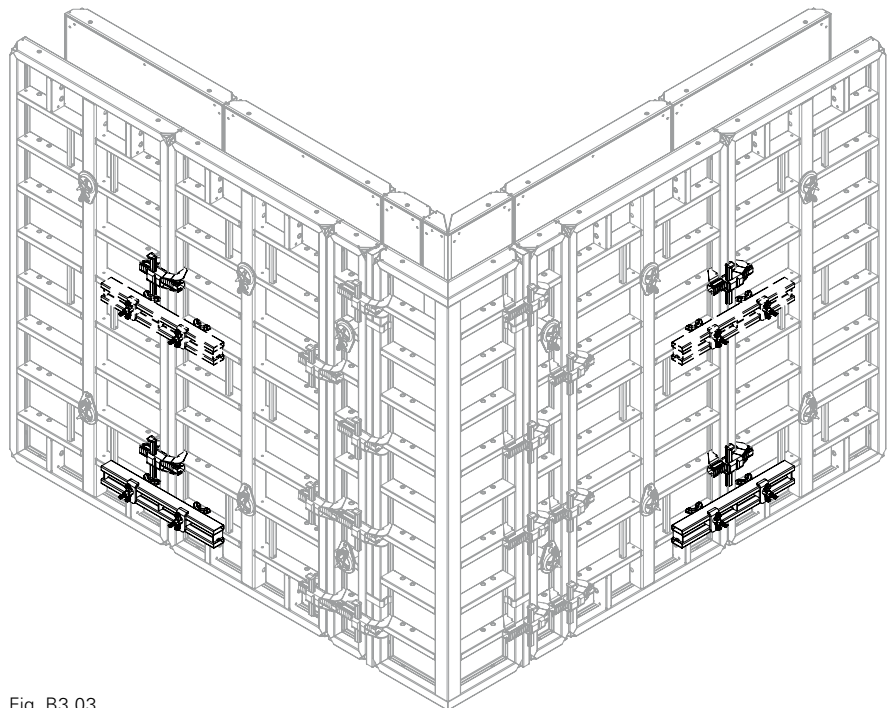


Fig. B3.03

B4 90° T-junctions with Inside Corner MXI 270 x 50/20

Wall thicknesses 15 – 40 cm



Perm. fresh concrete pressure: 60 kN/m²

Pos. Components

- 20** Alignment Coupler BFD
- 100** Multi Panel
MXM 270 x 60
- 102** Panel MX 270 x 45
- 103** Panel MX 270 x 60
- 140** Wall Thickness Compensator
WDA MX 270 x width or filler
timber
- 153** Inside Corner MXI 270 x 50/20

Assembly

1. Form the T-junction with Inside Corner MXI 270 50/20 (153).
2. Form the opposite straight wall with Panels MX 45 (102), MX 60 (103), or MXM 60 (100) – according to the wall thickness.
3. Install Wall Thickness Compensator (140) – according to the wall thickness.

Examples

- Wall thickness 15: Fig. B4.01
- Wall thickness 17.5: Fig. B4.02
- Wall thickness 20: Fig. B4.03
- Wall thickness 24/25: Fig. B4.04
- Wall thickness 30: Fig. B4.05
- Wall thickness 35/36: Fig. B4.06
- Wall thickness 40: Fig. B4.07

Compensations

- Wall thickness 15 + 17.5 + 24/25 + 30 + 35/36 + 40 cm: external compensation
- Wall thickness 20: without compensation



Max. panel width at the T-junction between corner and subsequent panel is 45 cm – MX 270 x 45 (102). (Fig. B4.08)

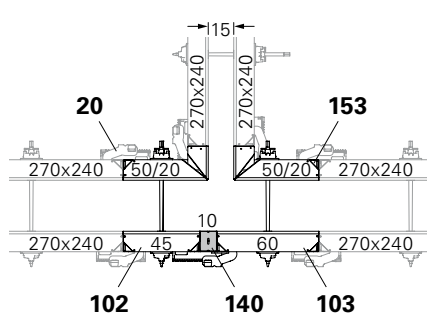


Fig. B4.01

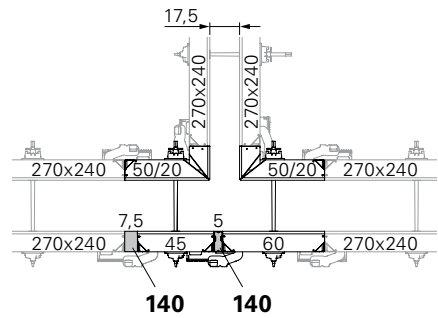


Fig. B4.02

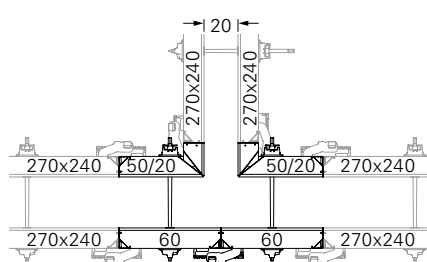


Fig. B4.03

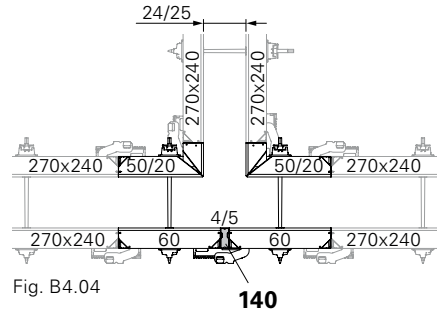


Fig. B4.04

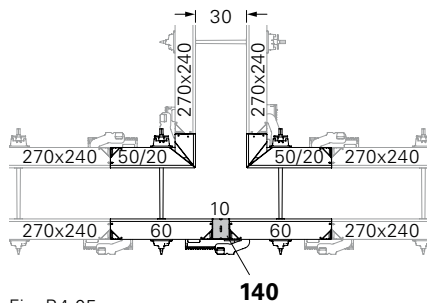


Fig. B4.05

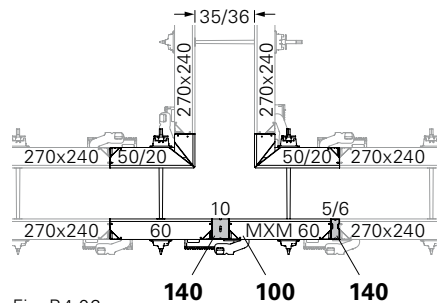


Fig. B4.06

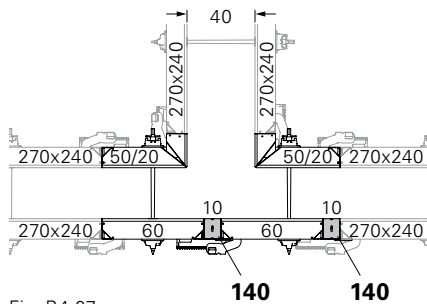


Fig. B4.07

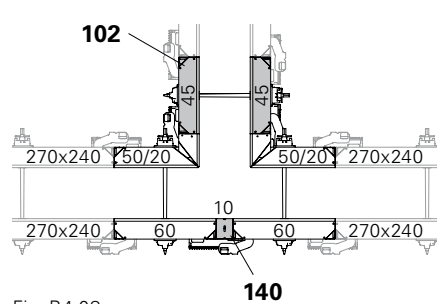


Fig. B4.08

B4 90° T-junctions with Inside Corner MXI 270 x 50/20

Arrangement of the Alignment Couplers

Valid for wall thicknesses 15 – 40 cm
(Fig. B4.09 + B4.10)

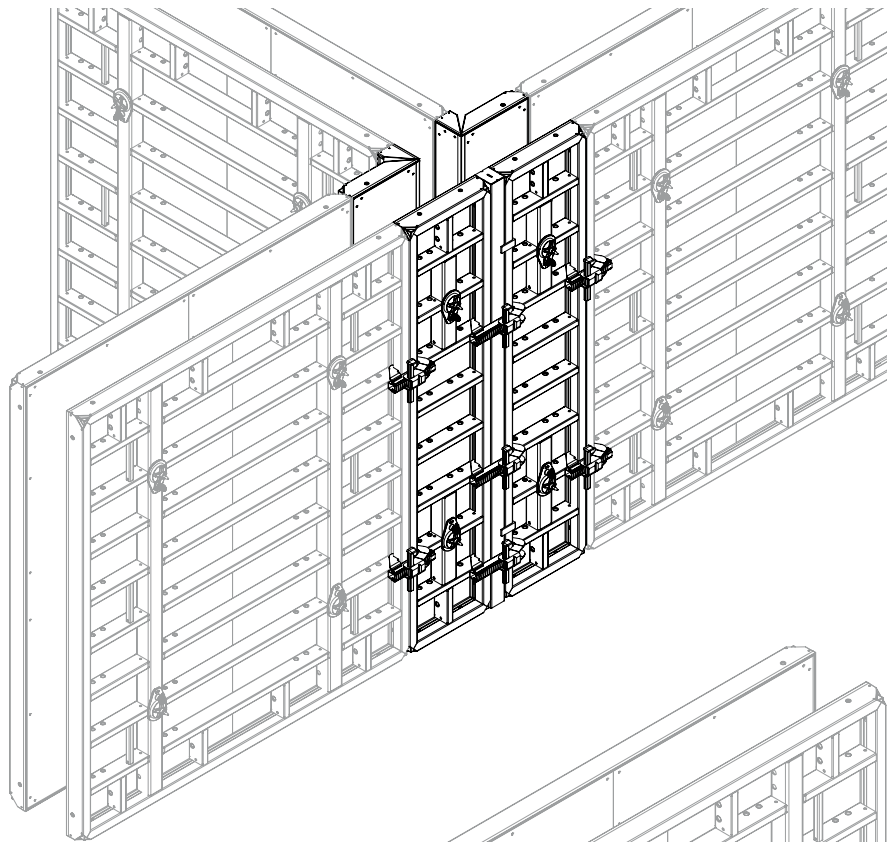


Fig. B4.09

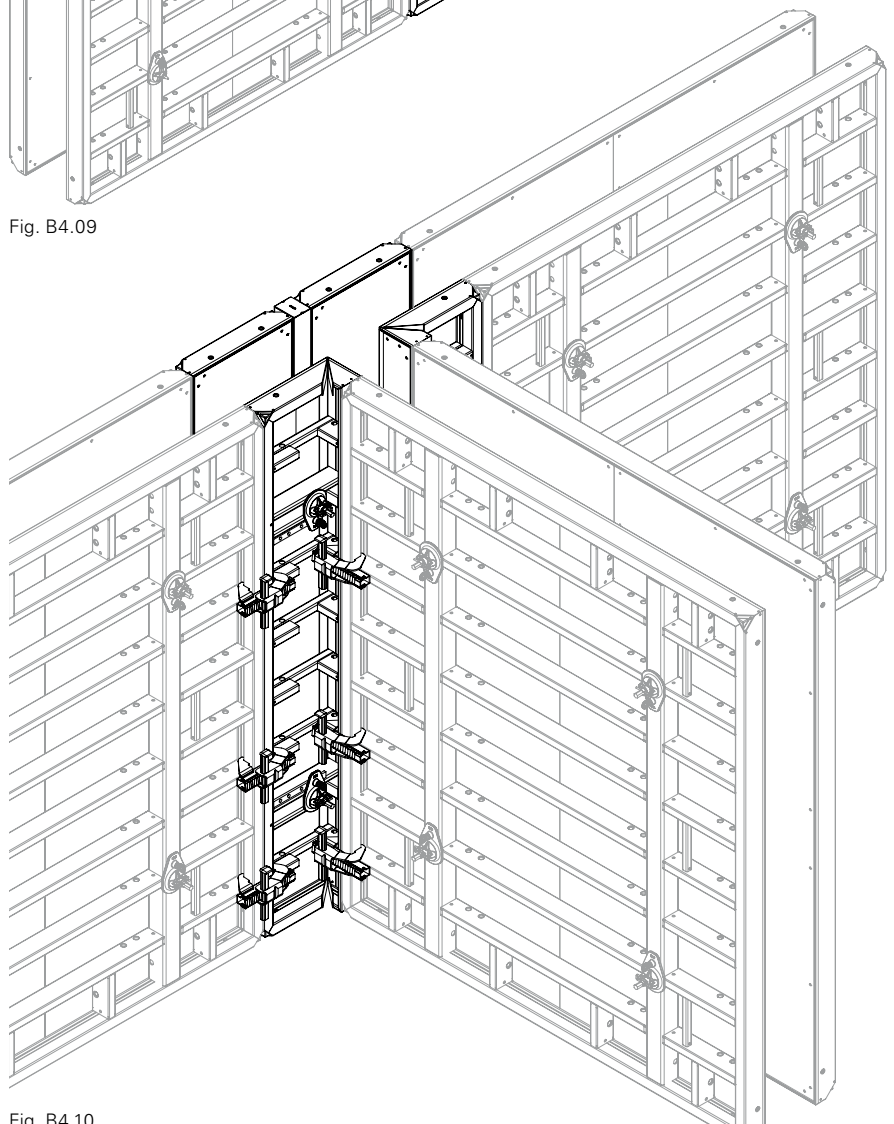


Fig. B4.10

Wall thicknesses 15 – 40 cm



Perm. fresh concrete pressure: 60 kN/m²

Pos. Components

- 20** Alignment Coupler BFD
- 22** Compensation Waler MAR 170-3
- 102** Panel MX 270 x 45
- 103** Panel MX 270 x 60
- 140** Wall Thickness Compensator WDA MX 270 x width or filler timber
- 152** Inside Corner MXI 270 x 60

Assembly

1. Form the T-junction with Inside Corner MXI 270 x 60 (152).
2. Form the opposite straight wall with Panel MX 270 x 45 (102) or MX 270 x 60 (103).
3. Install one Panel MX 270 x 45 (102) on the right and left respectively.
4. Install Wall Thickness Compensator (140) according to the wall thickness.
5. On the straight wall, install Compensation Waler MAR 170 (22) centrally to the outgoing wall.

Examples

- Wall thickness 15: Fig. B5.01
- Wall thickness 17.5: Fig. B5.02
- Wall thickness 20: Fig. B5.03
- Wall thickness 24/25: Fig. B5.04
- Wall thickness 30: Fig. B5.05
- Wall thickness 35/36: Fig. B5.06
- Wall thickness 40: Fig. B5.07

Compensations

- Wall thickness 15 + 30 cm: without compensation
- Wall thickness 17.5 + 20 + 24/25 + 35/36 + 40 cm: external compensation

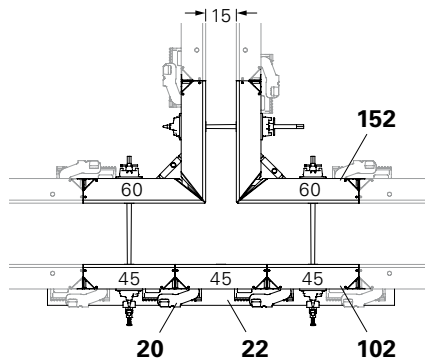


Fig. B5.01

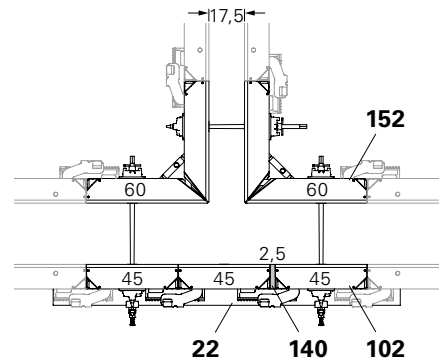


Fig. B5.02

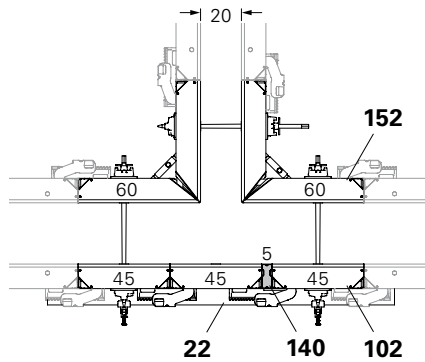


Fig. B5.03

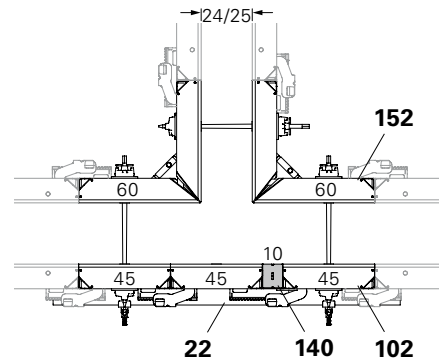


Fig. B5.04

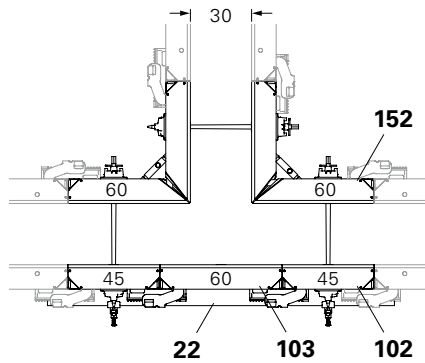


Fig. B5.05

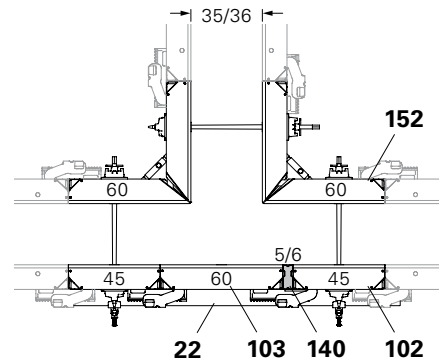


Fig. B5.06

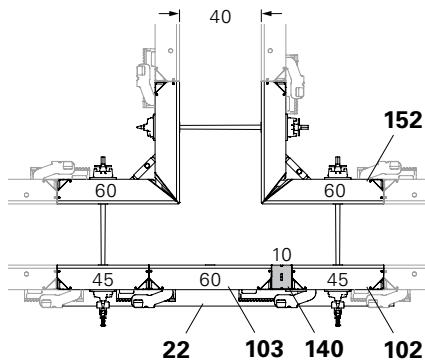


Fig. B5.07



With two Wall Thickness Compensators WDA MX: install one WDA MX each on the right and left of the middle panel. (not shown)

Arrangement of the Alignment Couplers and Compensation Walers

Valid for wall thicknesses 15 – 40 cm
(Fig. B5.08 + B5.09)

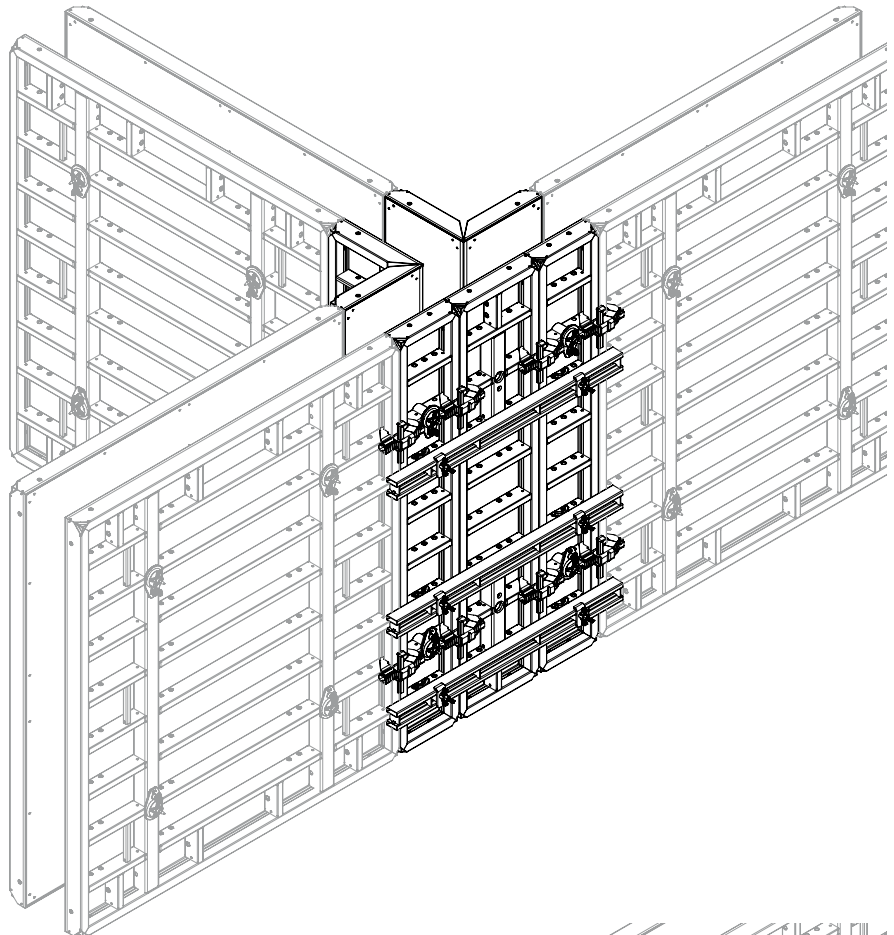


Fig. B5.08

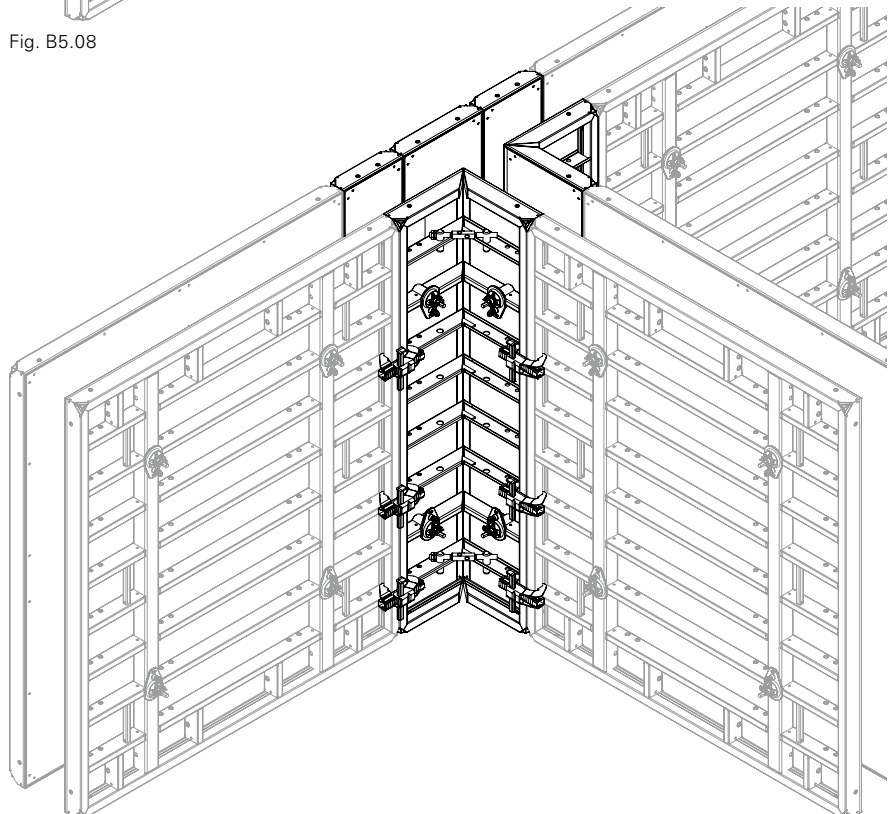


Fig. B5.09

B6 Panel connections following 90° T-junctions

Panel connections

For panels with widths $b \leq 120$ following 90° T-junctions, these must be strengthened at the next panel joint by means of a Compensation Waler MAR 85 (21). (Fig. B6.01)

Pos.	Components	Item no.
20	Alignment Coupler BFD 023500	
21	Compensation Waler MAR 85-3	124941

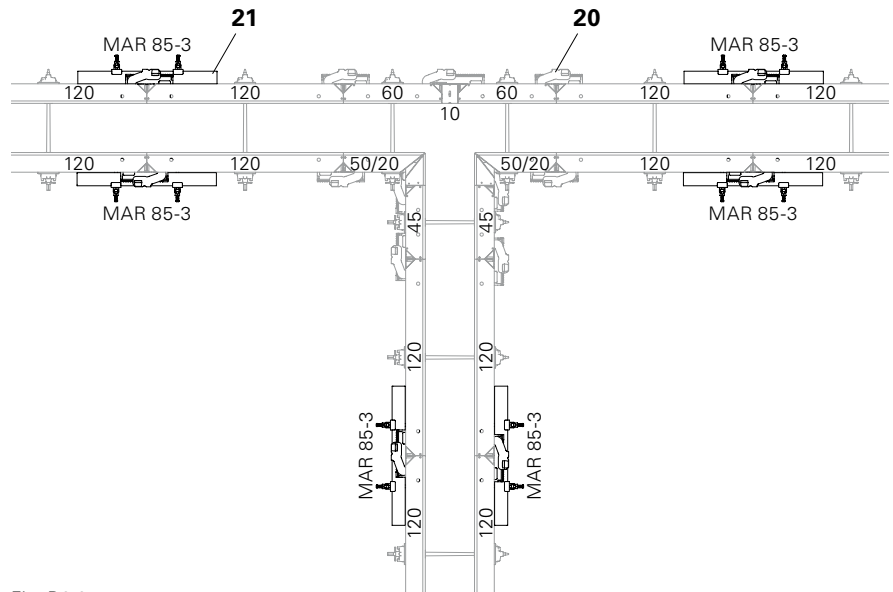


Fig. B6.01

Arrangement of the Alignment Couplers and Compensation Walers

With extensions, a second Compensation Waler MAR 85 (21) is required on the panel joint (shown as a dotted line). (Fig. B6.02 + B6.03)

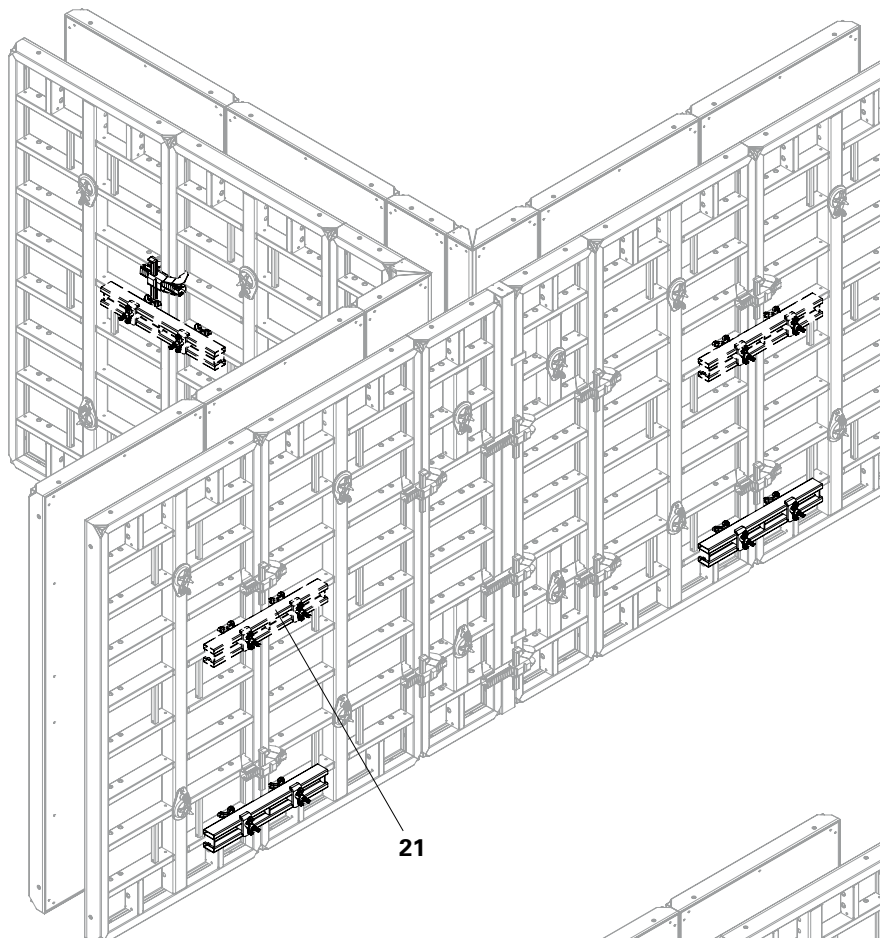


Fig. B6.02

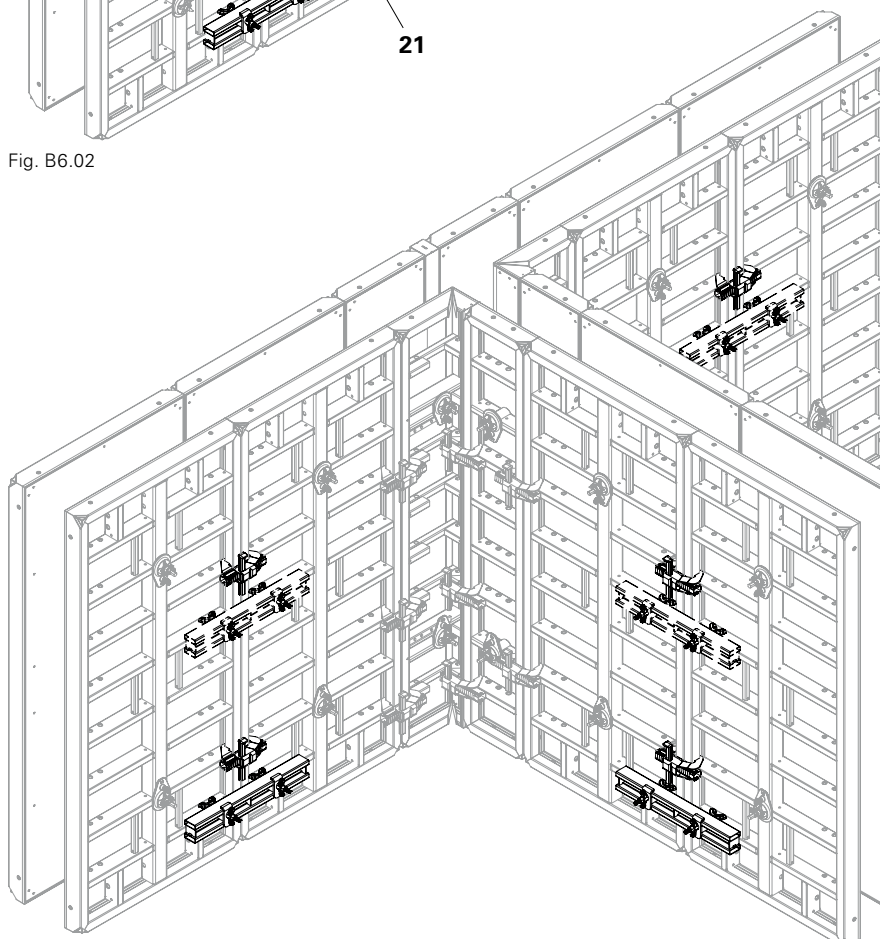


Fig. B6.03

Wall offsets ≤ 20 cm



Perm. fresh concrete pressure: 60 kN/m²

Pos. Components

- 18** Filler timber
- 20** Alignment Coupler BFD
- 22** Compensation Waler MAR 170-3
- 23** Wingnut Pivot Plate DW 15
- 24** Hook Tie DW 15, L = 400
- 100** Multi Panel
MXM 270 x 60
- 101** Panel MX 270 x 30

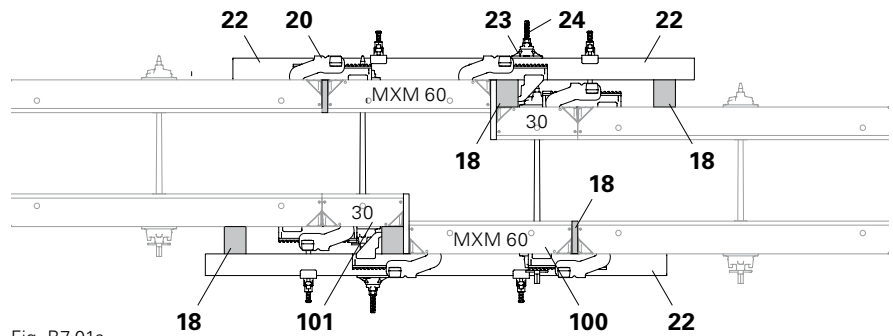


Fig. B7.01a

Shown: wall thickness 30 cm
(Fig. B7.01a + B7.01b)

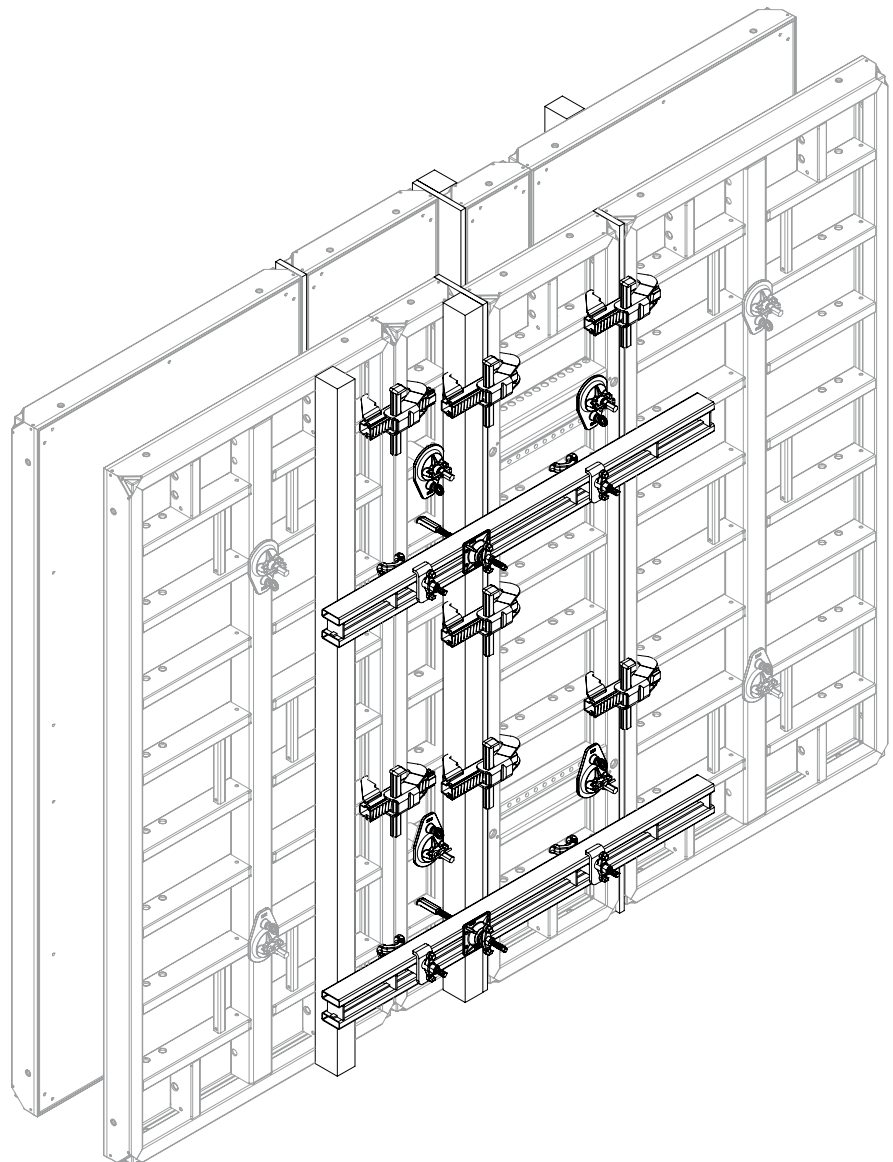


Fig. B7.01b

Wall offsets 20 – 28 cm



Perm. fresh concrete pressure: 60 kN/m²

With Inside Corner MXI 270 x 50/20

Pos. Components

- 18** Filler timber
- 20** Alignment Coupler BFD
- 21** Compensation Waler MAR 85-3
- 22** Compensation Waler MAR 170-3
- 102** Panel MX 270 x 45
- 153** Inside Corner MXI 270 x 50/20

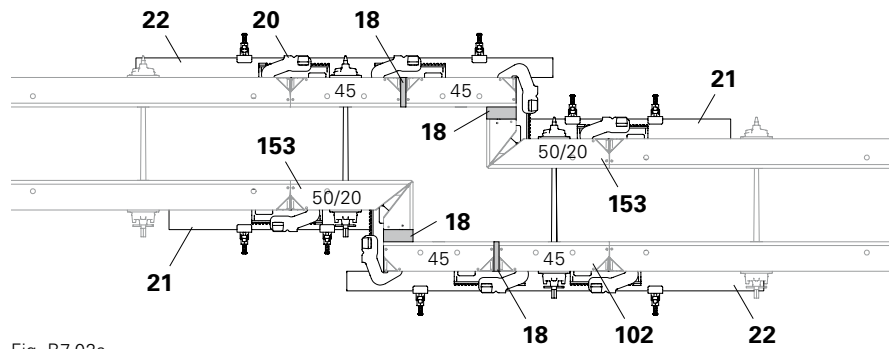


Fig. B7.02a

Shown: wall thickness 30 cm
(Fig. B7.02a + B7.02b)

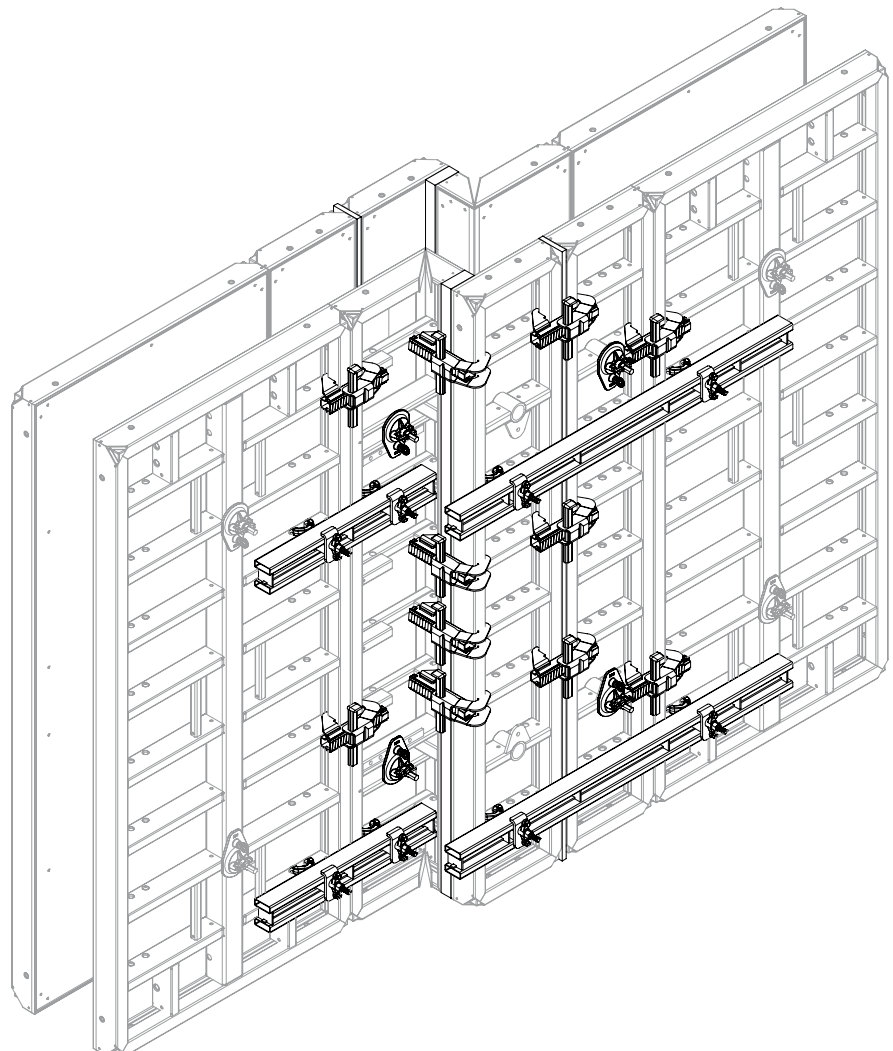


Fig. B7.02b

Wall offsets 28 – 38 cm



Perm. fresh concrete pressure: 60 kN/m²

With Inside Corner MXI 270 x 50/20

Pos. Components

- 18** Filler timber
- 20** Alignment Coupler BFD
- 21** Compensation Waler MAR 85-3
- 22** Compensation Waler MAR 170-3
- 23** Wingnut Pivot Plate DW 15
- 24** Hook Tie DW 15, L = 400
- 100** Multi Panel
MXM 270 x 60
- 101** Panel MX 270 x 30
- 102** Panel MX 270 x 45
- 153** Inside Corner MXI 270 x 50/20
- 240** Stopped Tie MX DW 20

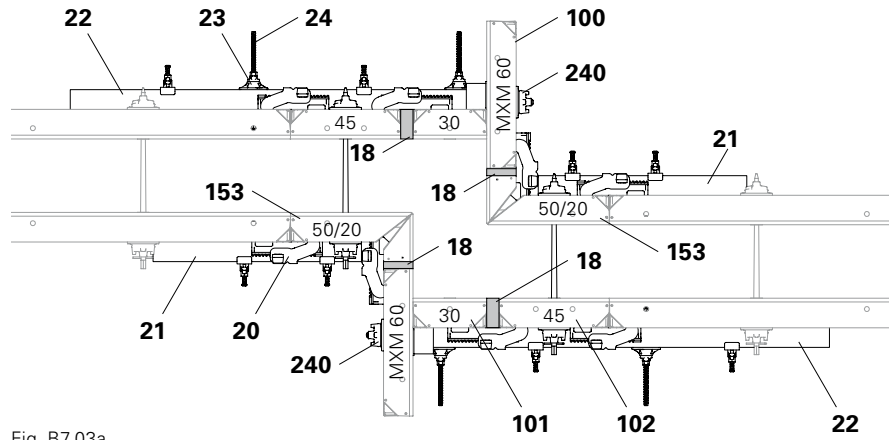


Fig. B7.03a

Shown: wall thickness 30 cm
(Fig. B7.03a to B7.03d)

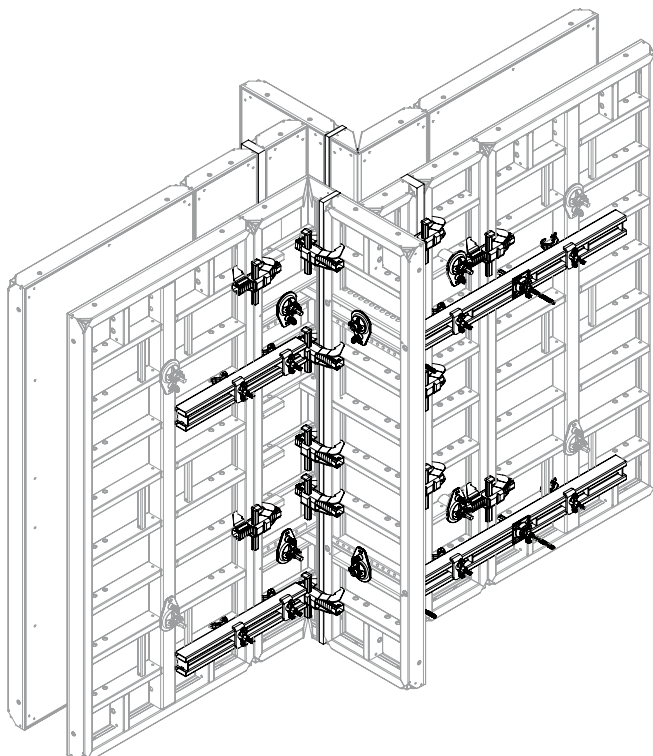


Fig. B7.03b

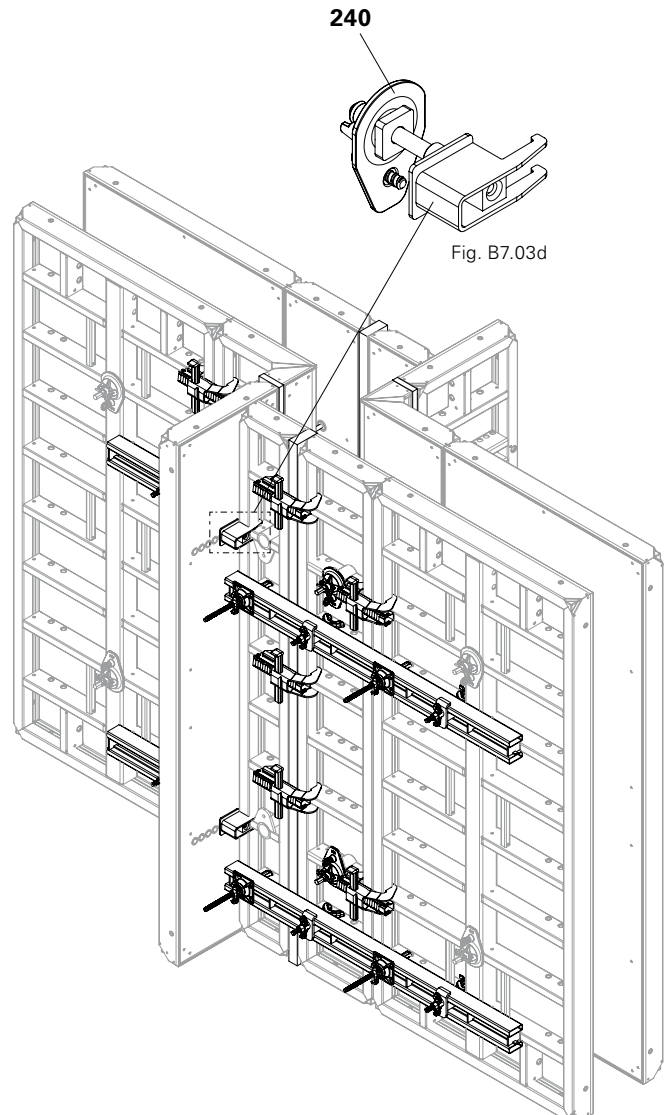


Fig. B7.03c

Wall offsets 38 – 50 cm



Perm. fresh concrete pressure: 60 kN/m²

With Inside Corner MXI 270 x 50/20

Pos. Components

- 18** Filler timber
- 20** Alignment Coupler BFD
- 21** Compensation Waler MAR 85-3
- 22** Compensation Waler MAR 170-3
- 23** Wingnut Pivot Plate DW 15
- 24** Hook Tie DW 15, L = 400
- 101** Panel MX 270 x 30
- 102** Panel MX 270 x 45
- 153** Inside Corner MXI 270 x 50/20

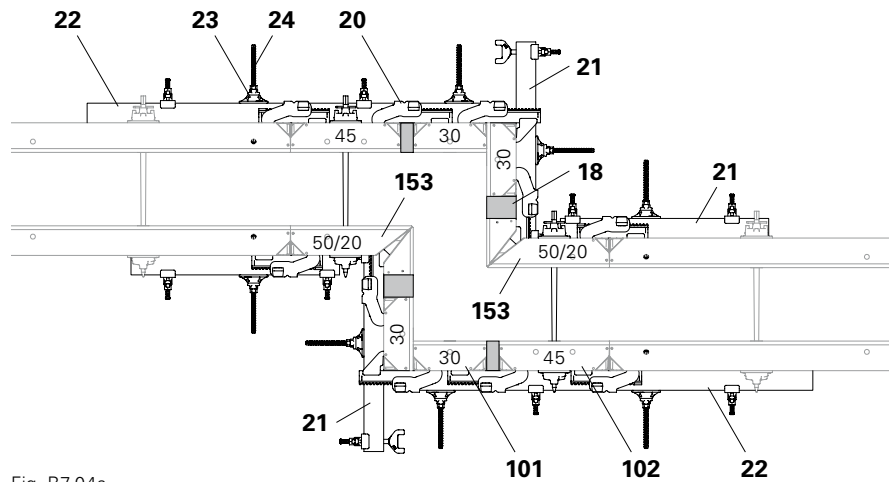


Fig. B7.04a

Shown: wall thickness 30 cm
(Fig. B7.04a + B7.04b)

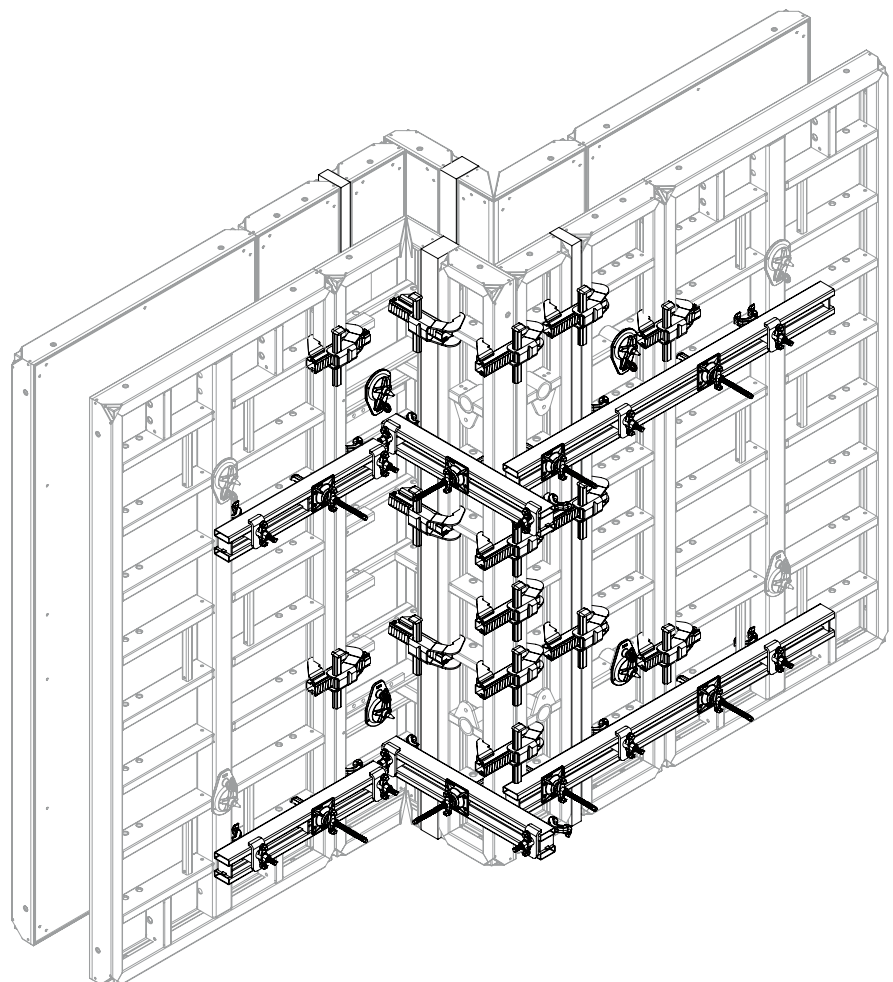


Fig. B7.04b

Wall offsets 50 – 65 cm



Perm. fresh concrete pressure: 60 kN/m²

With Inside Corner MXI 270 x 50/20

Pos. Components

- 18** Filler timber
- 20** Alignment Coupler BFD
- 21** Compensation Waler MAR 85-3
- 22** Compensation Waler MAR 170-3
- 23** Wingnut Pivot Plate DW 15
- 24** Hook Tie DW 15, L = 400
- 101** Panel MX 270 x 30
- 102** Panel MX 270 x 45
- 153** Inside Corner MXI 270 x 50/20

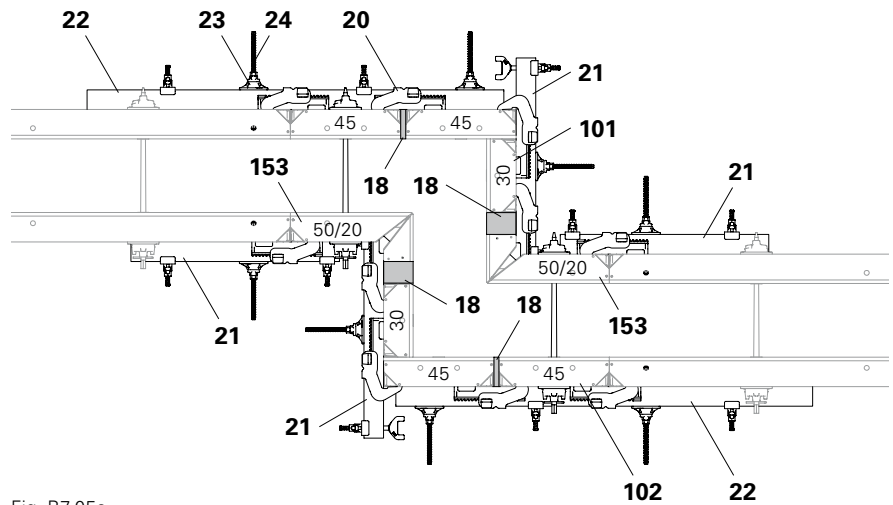


Fig. B7.05a

Shown: wall thickness 30 cm
(Fig. B7.05a + B7.05b)

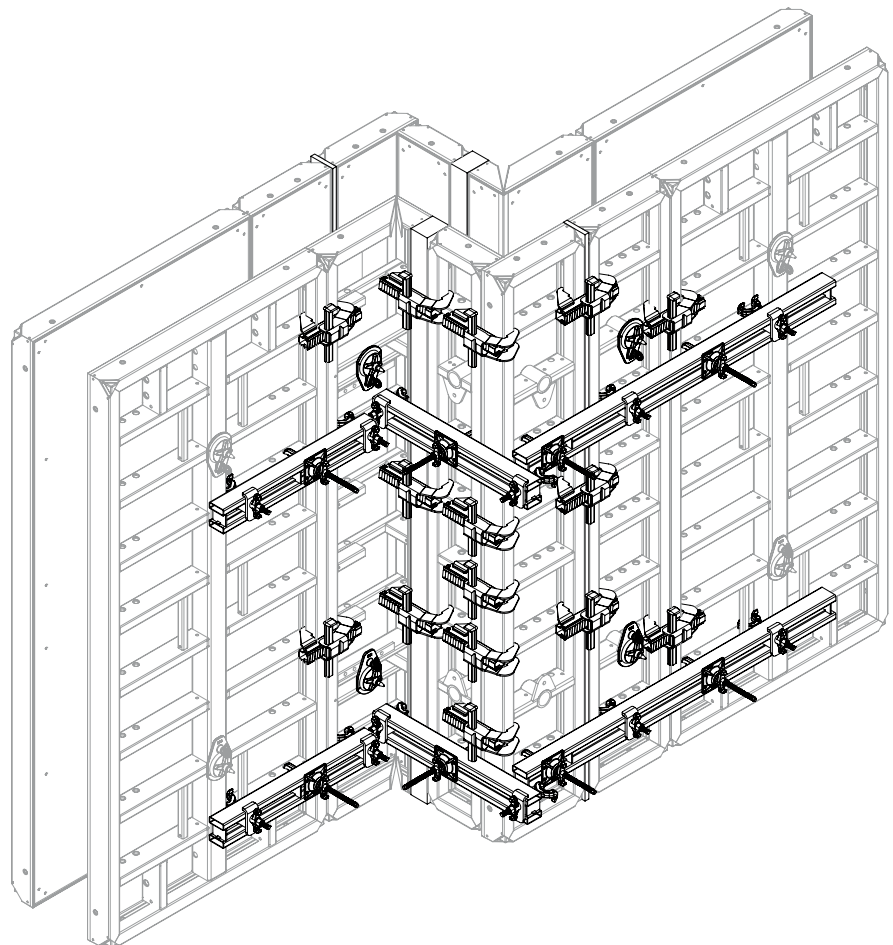


Fig. B7.05b

Wall offsets 65 – 79 cm



Perm. fresh concrete pressure: 60 kN/m²

With Inside Corner MXI 270 x 50/20
and Outside Corner MXA 270 x 45

Pos. Components

- 18** Filler timber
- 20** Alignment Coupler BFD
- 21** Compensation Waler MAR 85-3
- 22** Compensation Waler MAR 170-3
- 23** Wingnut Pivot Plate DW 15
- 24** Hook Tie DW 15, L = 400
- 101** Panel MX 270 x 30
- 151** Outside Corner MXA 270 x 45
- 153** Inside Corner MXI 270 x 50/20

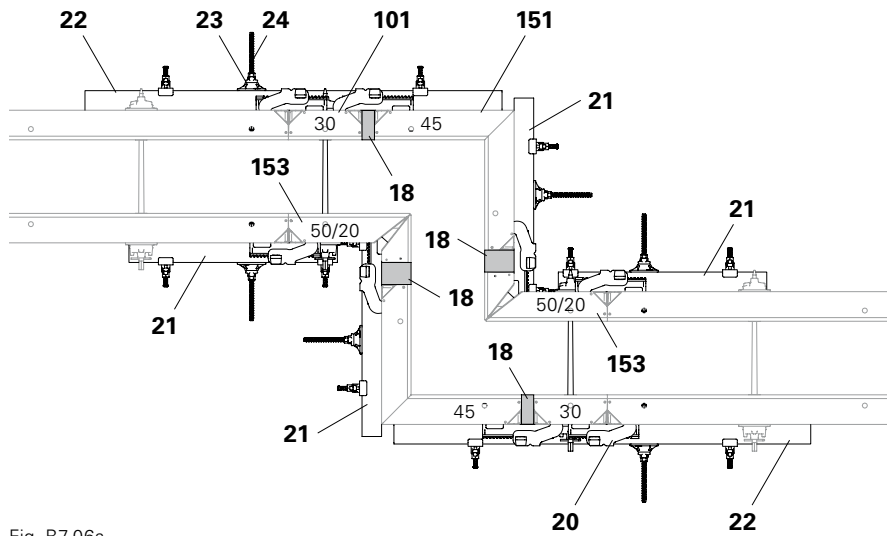


Fig. B7.06a

Shown: wall thickness 30 cm
(Fig. B7.06a + B7.06b)

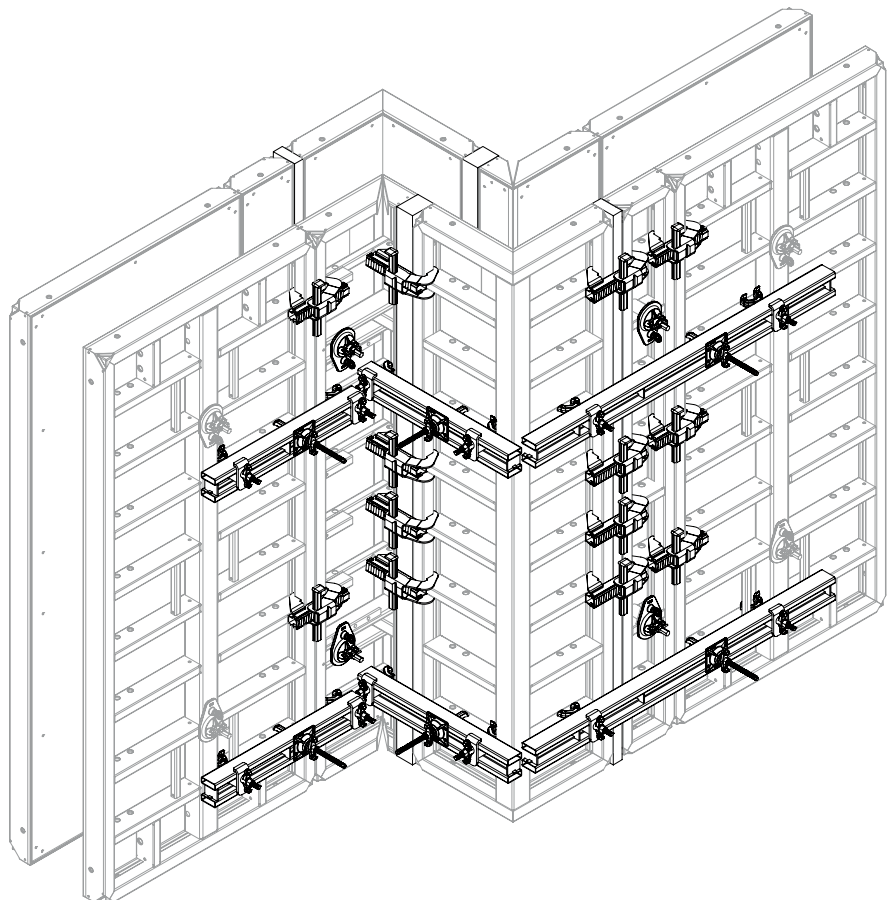


Fig. B7.06b

Wall offsets 65 – 95 cm



Perm. fresh concrete pressure: 60 kN/m²

With Inside Corner MXI 270 x 50/20

Pos. Components

- 18** Filler timber
- 20** Alignment Coupler BFD
- 21** Compensation Waler MAR 85-3
- 22** Compensation Waler MAR 170-3
- 23** Wingnut Pivot Plate DW 15
- 24** Hook Tie DW 15, L = 400
- 102** Panel MX 270 x 45
- 153** Inside Corner MXI 270 x 50/20

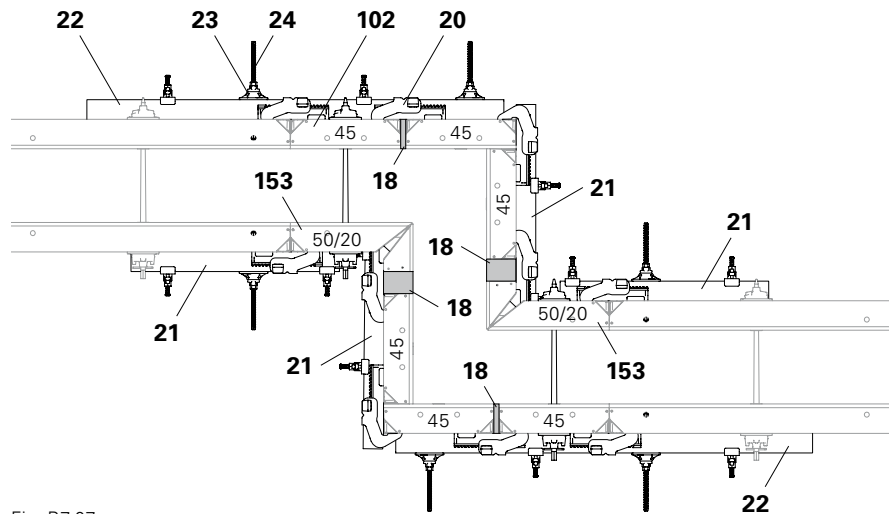


Fig. B7.07a

Shown: wall thickness 30 cm (Fig. B7.07a + B7.07b)

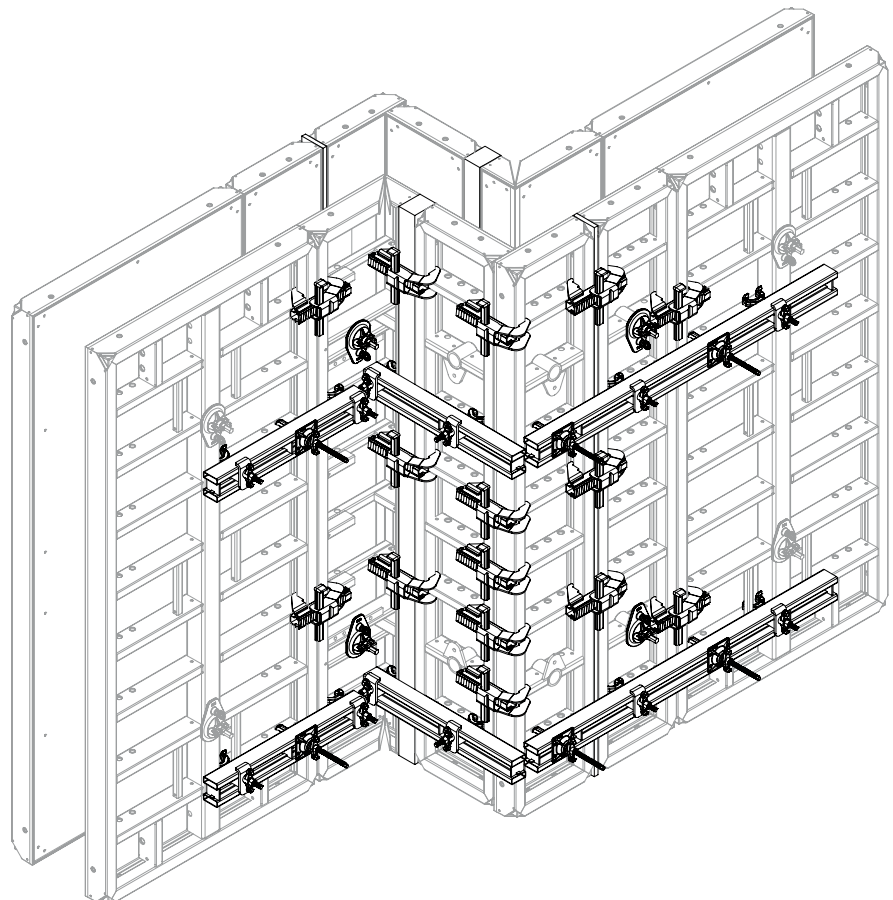


Fig. B7.07b

Wall offsets 95 – 124 cm



Perm. fresh concrete pressure: 60 kN/m²

With Inside Corner MXI 270 x 50/20 and Outside Corner MXA 270 x 45



- 95 – 109 cm: Panel MX 270 x 30
- 110 – 124 cm: Panel MX 270 x 45

Pos. Components

- 18** Filler timber
- 20** Alignment Coupler BFD
- 21** Compensation Waler MAR 85-3
- 22** Compensation Waler MAR 170-3
- 23** Wingnut Pivot Plate DW 15
- 24** Hook Tie DW 15, L = 400
- 101** Panel MX 270 x 30
for wall offsets 95 – 109 cm
- 102** Panel MX 270 x 45
for wall offsets 110 – 124 cm
- 151** Outside Corner MXA 270 x 45
- 153** Inside Corner MXI 270 x 50/20

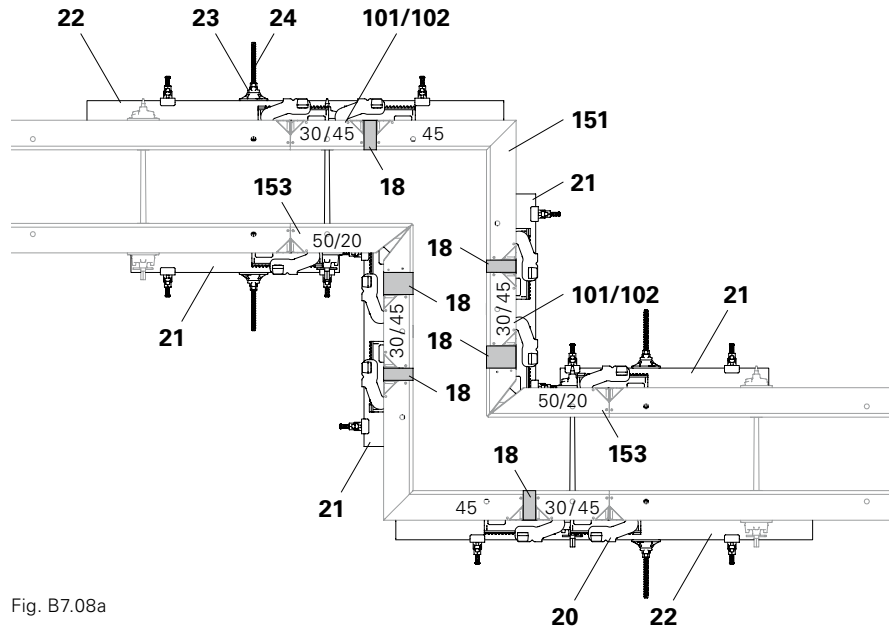


Fig. B7.08a

Shown: wall thickness 30 cm (Fig. B7.08a + B7.08b)

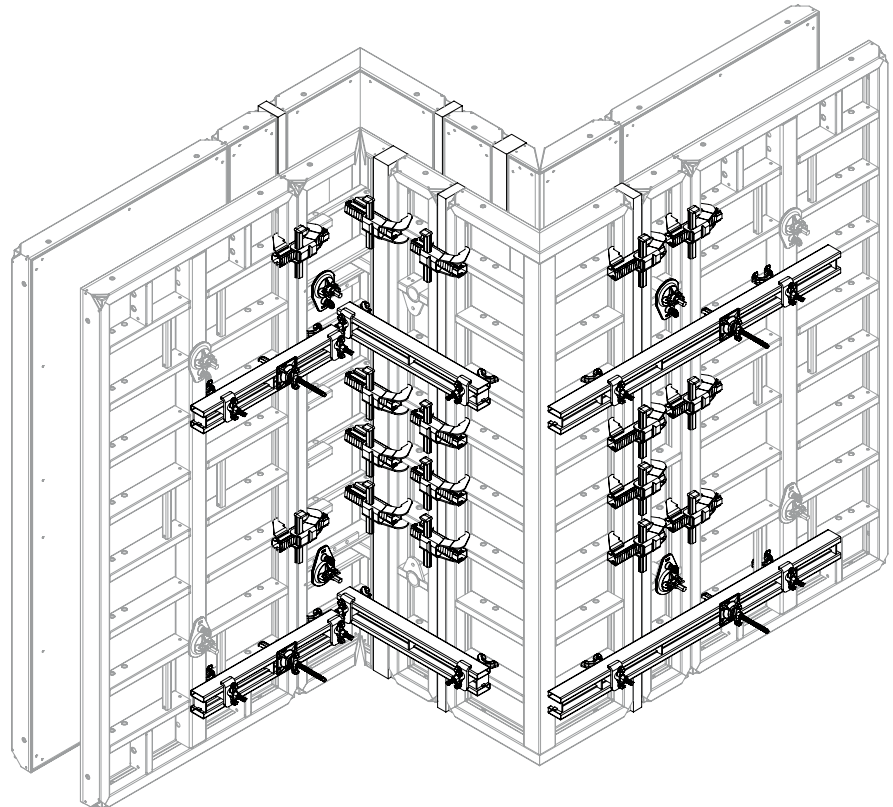


Fig. B7.08b

B8 75° to 165° corners with Articulated Corners MXGI 270 and MXGA 270



- Perm. fresh concrete pressure: 60 kN/m²
- Wall thickness 30 cm - shown. The illustrations in Fig. B8.06 + B8.07 apply to 65° to 150° corners and can also be used for 75° and 165° corners. The panel strut actually used is specified in the respective "Arrangement of panel connections" tables.

75° corners

Pos.	Components	Item no.
14	Steel Waler Universal SRU U120, L = 1.22 m	103874
15	Tie Yoke SKZ	024210
20	Alignment Coupler BFD	023500
21	Compensation Waler MAR 85-3	124941
25	Tie Rod DW 15, L = 400	030030
44	Wingnut DW 15	030100
101	Panel MX 270 x 30	112090
102	Panel MX 270 x 45	112078
140	Wall Thickness Compensation WDA MX 270 x width or filler timber ≤ 10 cm acc. to width	
175	Articulated Corner MXGI 270	113203
176	Articulated Corner MXGA 270	111872

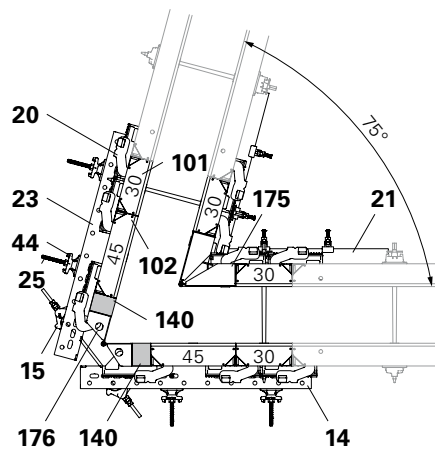


Fig. B8.01

Arrangement of panel connections

75° angles (Fig. B8.01)	Panel strut on articulated corner	
	Outside	Inside
BFD (20)	3 5 8	3 8
MAR 85 (21)	-	1 6
SRU 122 (14)**	1 6	-

* Offset arrangement of BFD

** with Tie Yoke SKZ (15), Tie Rod (25) and Wingnut (44)

B8 75° to 165° corners with Articulated Corners MXGI 270 and MXGA 270

105° to 150° corners

Pos.	Components	Item no.
20	Alignment Coupler BFD 023500	
21	Compensation Waler MAR 85-3	124941
100	Multi Panel MXM 270 x 60	112849
101	Panel MX 270 x 30 for 105° and 135° angles	112090
102	Panel MX 270 x 45 for 120° and 150° angles	112078
140	Wall Thickness Compensation WDA MX 270 x width or filler timber ≤ 10 cm acc. to width	
175	Articulated Corner MXGI 270	113203
176	Articulated Corner MXGA 270	111872



105° + 135° angles:
Offset arrangement of Alignment
Couplers (20) on the Internal Articulated
Corner (175). (Fig. B8.02 + Fig. B8.04)

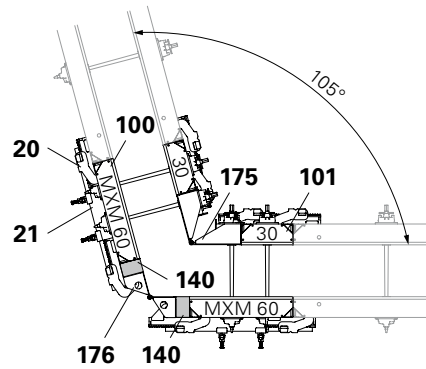


Fig. B8.02

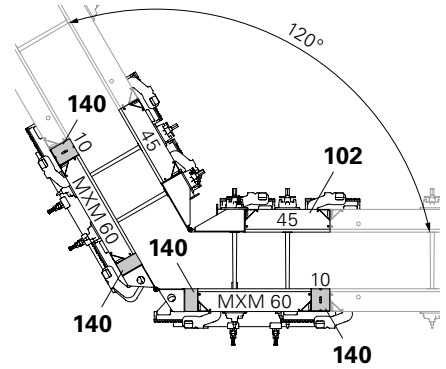


Fig. B8.03

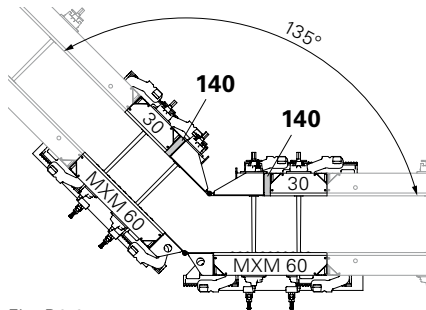


Fig. B8.04

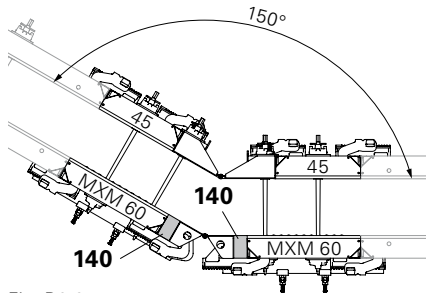


Fig. B8.05

Arrangement of panel connections

Angle *	Panel strut on Articulated Corner	
	Outside	Inside
105° to 150°		
BFD (20)	3 5 8	1 6
MAR 85 (21)	1 6	-

* Angle
 105° – Fig. B8.02 + B8.06 + B8.07
 120° – Fig. B8.03 + B8.06 + B8.07
 135° – Fig. B8.04 + B8.06 + B8.07
 150° – Fig. B8.05 + B8.06 + B8.07

Outside

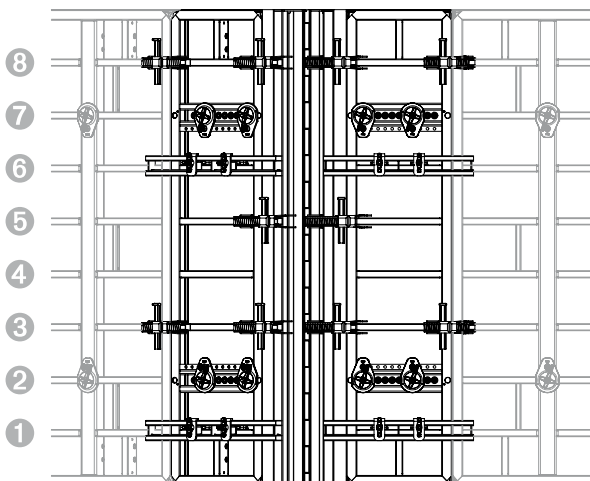


Fig. B8.06

Inside

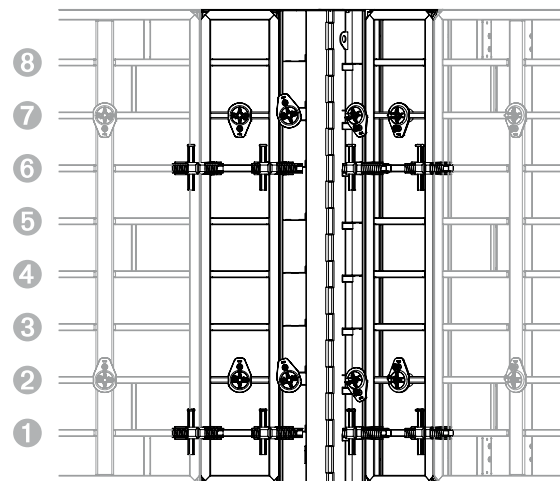


Fig. B8.07

B8 75° to 165° corners with Articulated Corners MXGI 270 and MXGA 270

165° corners

Pos.	Components	Item no.
20	Alignment Coupler BFD 023500	
21	Compensation Waler MAR 85-3	124941
100	Multi Panel MXM 270 x 60	112849
102	Panel MX 270 x 45	112078
140	Wall Thickness Compensation WDA MX 270 x width or filler timber ≤ 10 cm acc. to width	
175	Articulated Corner MXGI 270	113203
176	Articulated Corner MXGA 270	111872

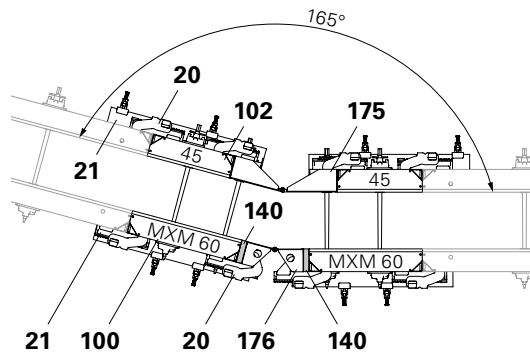


Fig. B8.08

Arrangement of panel connections

Angle 165° (Fig. B8.08)	Panel strut on Articulated Corner	
	Outside	Inside
BFD (20)	3 8	3 8
MAR 85 (21)	1 4 6	1 6

Wall Thickness Compensator WDA MX 270

Length compensation up to 10 cm

Pos.	Components	Qty.
20	Alignment Coupler BFD	3x
140	Wall Thickness Compensation WDA MX 270 x width or filler timber	1x



No additional anchors required!

Length compensation takes place with Wall Thickness Compensator WDA MX 270 x width or using timber which has been cut to size (140).

Note: number and arrangement of the Alignment Couplers BFD (20).
(Fig. B9.01)

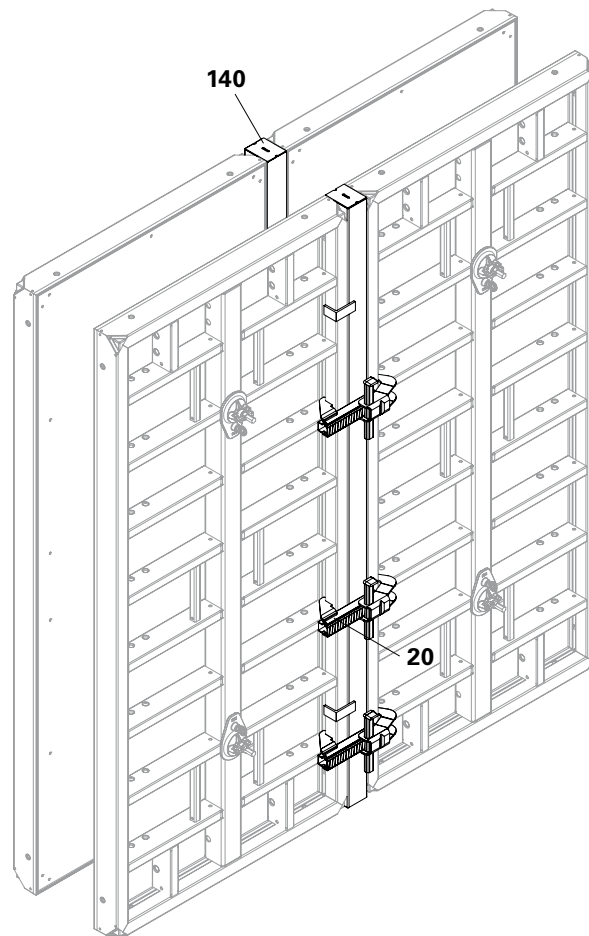


Fig. B9.01

Filler Profile TPP

Length compensation from 10 to 36 cm



- Perm. fresh concrete pressure
80 kN/m² for: $b \geq 10$ and $b < 30$ cm
- Perm. fresh concrete pressure:
60 kN/m² for: $b \geq 30$ and $b \leq 36$ cm

Pos.	Components	Qty.
20	Alignment Coupler BFD	4x
21	Compensation Waler MAR 85-3	2x
51	Plywood filler 21 mm	1x
52	Filler Profile TPP 270	2x
18	Filler timber (alternative)	2x

When anchoring, ensure that the tie forces are transferred centrally through the Compensation Waler MAR 85 (21) to the adjacent panels.
(Fig. B9.02b)

Installation (Fig. B9.02 + B9.02a)



The Filler Profile is only available in a length of 330 cm. As an alternative to the Filler Profile TPP, timber (2x) can be used (not shown).

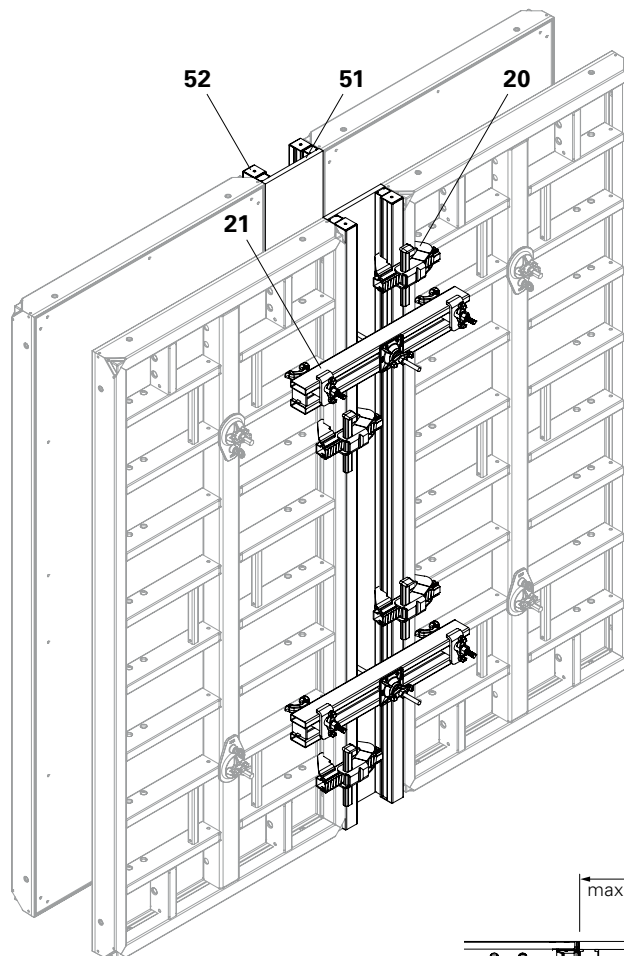


Fig. B9.02

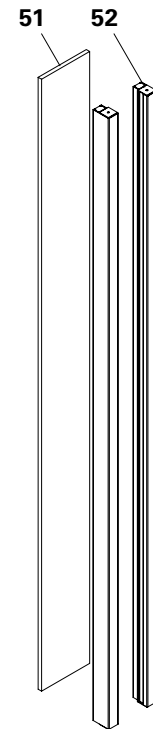


Fig. B9.02a

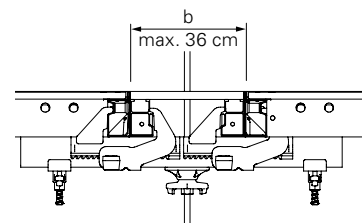


Fig. B9.02b

Stopend Waler



The fresh concrete pressure of the stopend formwork is transferred to the MAXIMO Panels by means of the Stopend Walers.

Wall end with Panels MX 270 x width

Valid for MAXIMO Panels MX:
270 x 30/45/60/90/120/240
Shown: 270 x 120

Wall thickness ≤ 30 cm

- Perm. fresh concrete pressure 80 kN/m² (Fig. B10.01 + B10.01b)
- Perm. fresh concrete pressure 60 kN/m² (Fig. B10.02 + B10.01b)

Pos.	Components	Item no.
18	Filler timber	
50	Stopend Waler MX 15 – 40	127732
51	Plywood filler 21 mm	



Fix 3 or 2 Stopend Walers with 2 nails each thus ensuring that the filler timber does not slide inwards. (Fig. B10.01a)
Section A-A
Wall thickness 15 to wall thickness 30 (Fig. B10.01b)

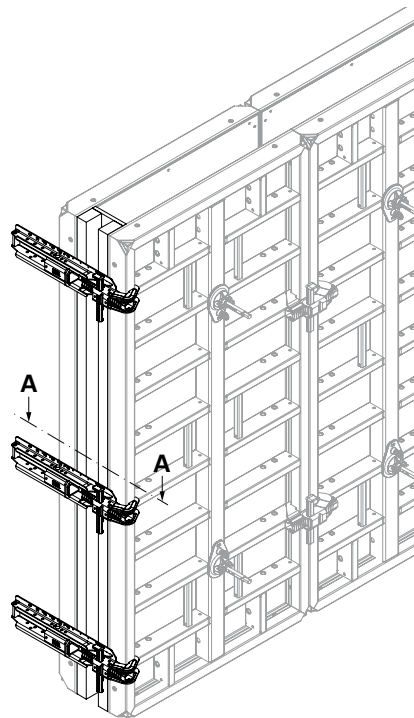


Fig. B10.01

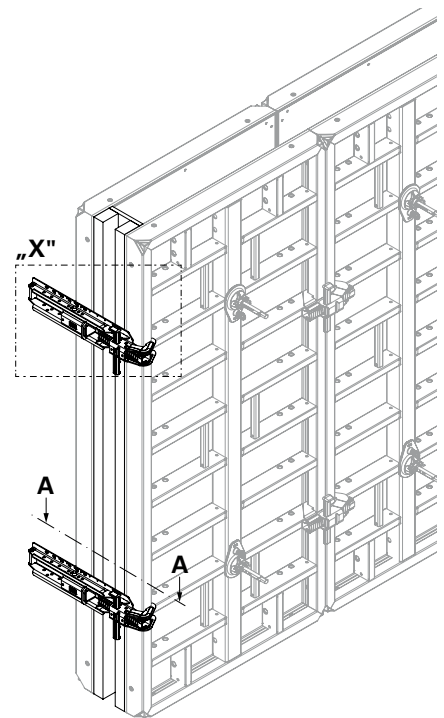


Fig. B10.02

Detail "X"

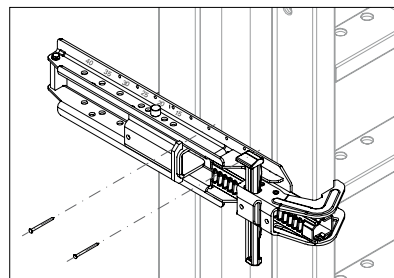


Fig. B10.01a

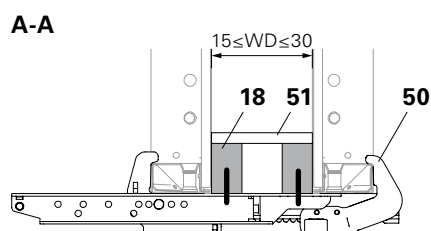


Fig. B10.01b

B10 Stopend formwork

Wall thickness > 30 cm

- Perm. fresh concrete pressure 80 kN/m² (Fig. B10.03)
- Perm. fresh concrete pressure 60 kN/m² (Fig. B10.04)

Pos.	Components	Item no.
18	Filler timber	
50	Stopend Waler	127732
51	Plywood filler 21 mm	



Fix 3x Stopend Walers with 2 nails each thus ensuring that the filler timber does not slide inwards. (Fig. B10.01a)

Section B-B
Wall thickness > 30 to wall thickness 40 (Fig. B10.03a)

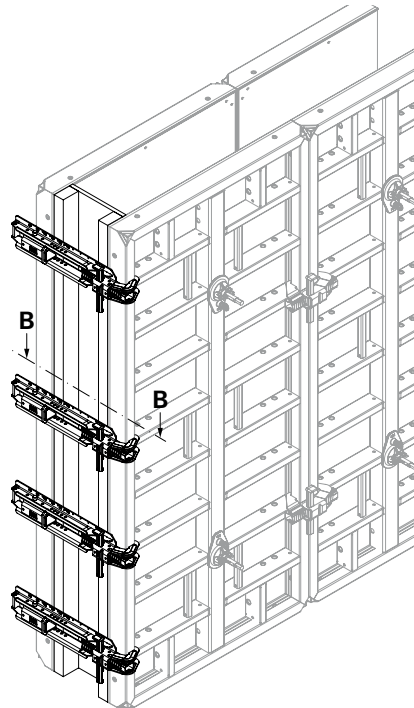


Fig. B10.03

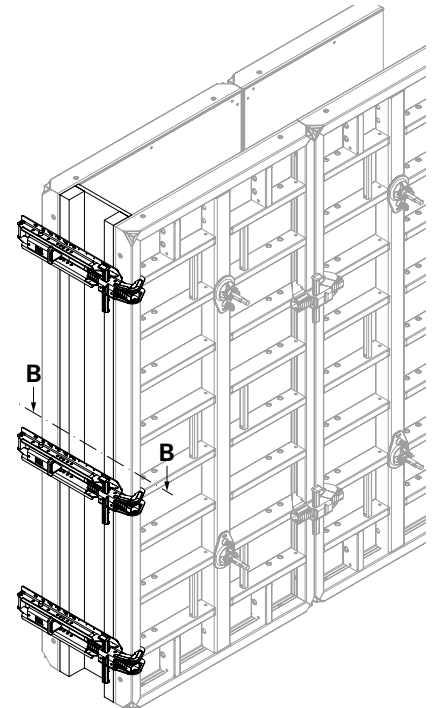


Fig. B10.04

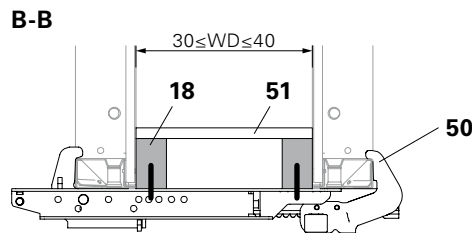


Fig. B10.03a

Stopend Tie and Compensation Waler

For wall thickness ≤ 40 cm



The fresh concrete pressure of the stopend formwork is transferred to the MAXIMO Panels via the Stopend Ties and Walers 85.

Wall end with Panels MX 270 x width

Valid for MAXIMO Panels:
MX 270 x 30/45/60/120/90
Shown: MX 270 x 120
(Fig. B10.05 + B10.06)

Pos.	Components	Qty.
18	Filler timber	2x
23	Wingnut Pivot Plate DW 15	10x
25	Tie Rod DW 15	2x
27	Top Tie Bracket-2 AH	4x
28	Stopend Tie TS	6x
51	Plywood filler 21 mm	1x
241	Waler 85	3x

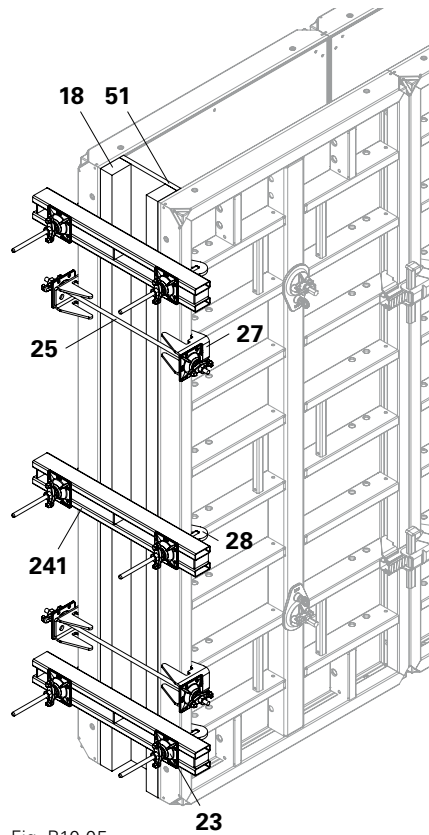


Fig. B10.05

Sectional views:

- Top Tie Bracket-2 AH (27) with Tie Rod (25) and Wingnut Pivot Plate (23). (Fig. B10.06a)
- Waler 85 (241) with Stopend Tie TS (28) and Wingnut Pivot Plate (23). (Fig. B10.06b)



As an alternative to Waler 85 (241), the Compensation Waler MAR 85-3 can also be used.

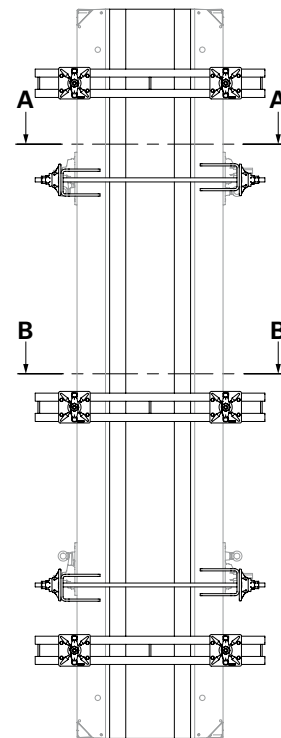


Fig. B10.06

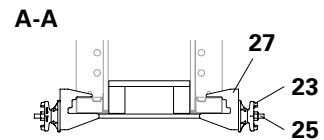


Fig. B10.06a

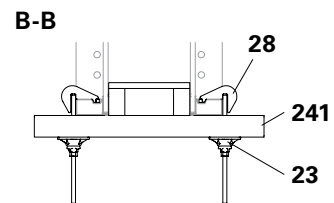


Fig. B10.06b

Wall end with Panel MX 270 x 240

(Not shown)

Pos.	Components	Qty.
18	Filler timber	2x
23	Wingnut Pivot Plate DW 15	8x
28	Stopend Tie TS	8x
51	Plywood filler 21 mm	1x
241	Waler 85	4x

Waler 85 (241) with Stopend Tie TS (28) and Wingnut Pivot Plate (23).



As an alternative to Waler 85 (241), the Compensation Waler MAR 85-3 can also be used.

Alignment Coupler BFD

Use Panel MX 270 x 30 (101) as stopend panel for 30 cm wall thicknesses. (Fig. B10.07)

Pos. Components

20	Alignment Coupler BFD
101	Panel MX 270 x 30



Alternatively, it is possible to use Panel TRIO 270 x 24 as a stopend panel.

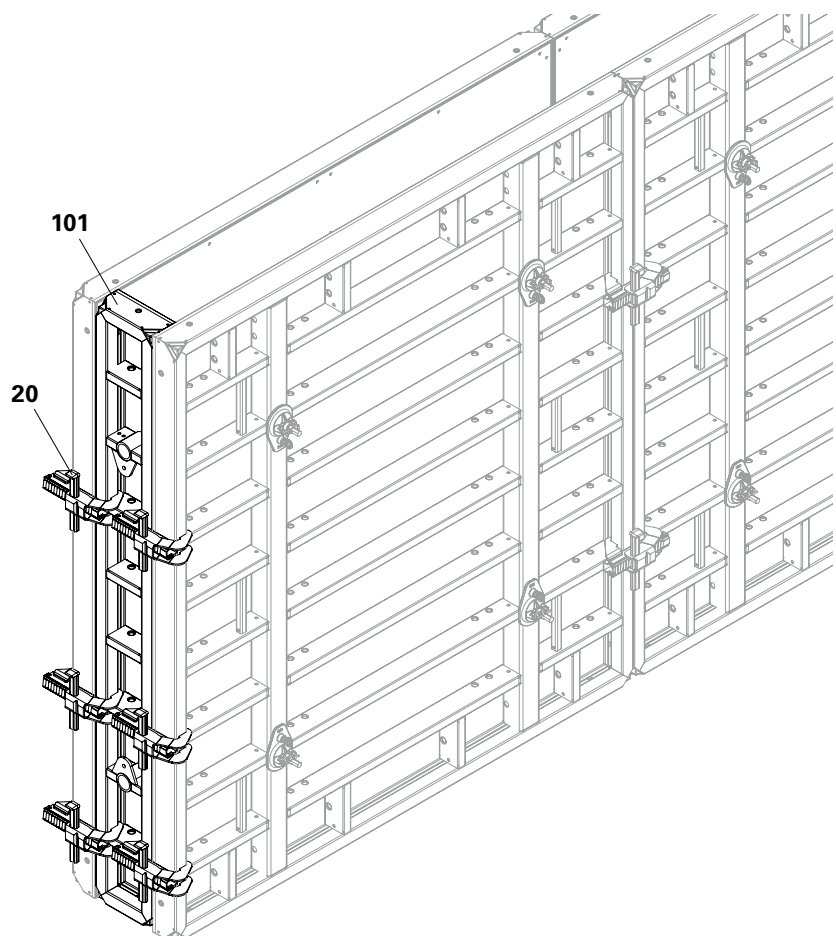


Fig. B10.07

Stopend panel reinforcement without Water Bar Installation MT

Height 270 cm (Fig. B10.08a)

Height 120 cm (Fig. B10.08b)

Consisting of:

- 2x Outside Pieces AT 3 (55) for approx. 2.5 cm concrete cover or 2x Outside Pieces AT 5 for approx. 5 cm concrete cover
- 1x Centre Piece MT (56) (Fig. B10.09)



- Perm. fresh concrete pressure dependent on the wall thickness
67.5 kN/m² for wall thickness ≤ 30 cm and < 35 cm
60.0 kN/m² for wall thickness ≥ 35 cm and ≤ 40 cm
- The rubber lip (55.1) allows a continuous reinforcement thickness of max. 16 mm.

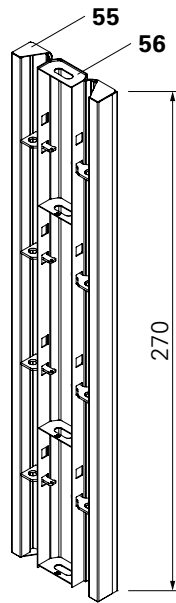


Fig. B10.08a

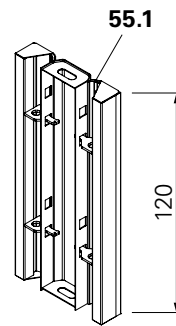


Fig. B10.08b

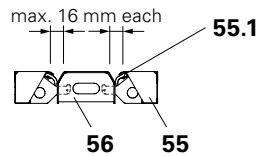


Fig. B10.09

Concrete cover c:

$$c = \frac{d - b}{2} - \varnothing \text{ reinforcement}$$

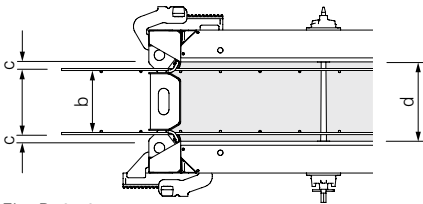


Fig. B10.10

Assembly

1. Position primary formwork.
2. Fix Outside Piece AT (55) to the primary formwork by means of the Alignment Coupler BFD (20).
3. Install first row of reinforcement.
4. Position Centre Piece MT (56).
5. Install second row of reinforcement.
6. Fix Outside Piece AT to the primary formwork with Alignment Coupler BFD.
7. Position closing formwork, and insert Outer Piece AT into the Centre Piece MT.

(Fig. B10.10 + B10.11)

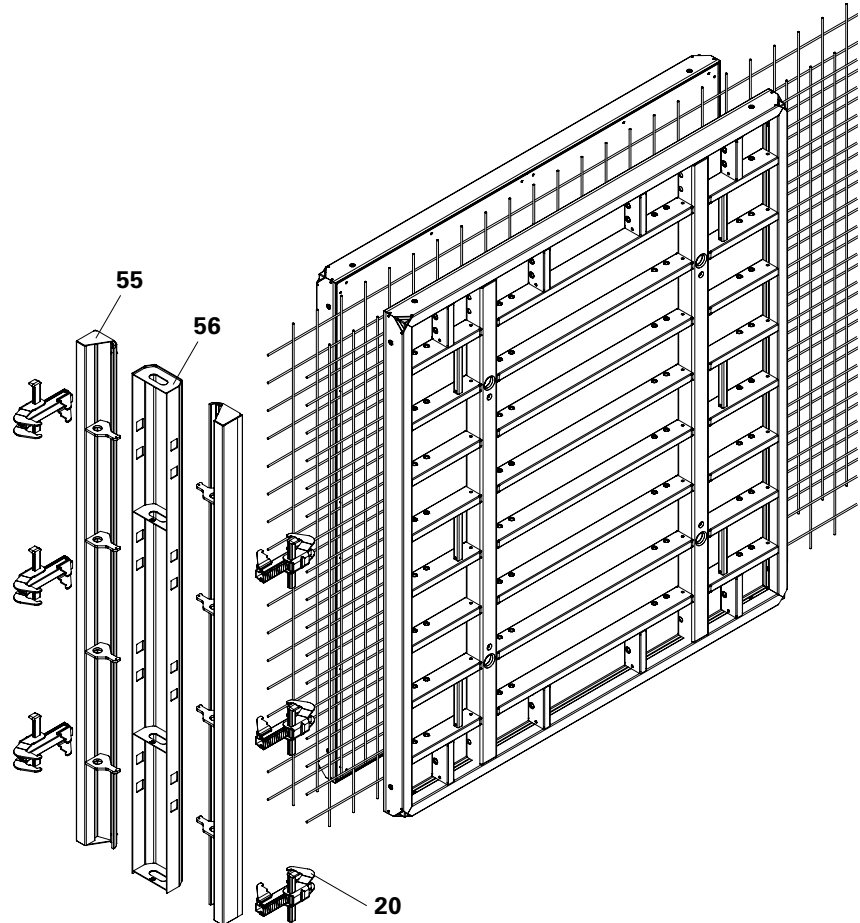


Fig. B10.11

Stopend panel reinforcement with Water Bar Installation MTF

Height 270 cm (Fig. B10.12a)
 Height 120 cm (Fig. B10.12b)

Consisting of:

- 2x Outside Pieces AT (55) for concrete cover
 - AT 3 for approx. 2.5 cm or
 - AT 5 for approx. 5 cm
- 1x Centre Piece MTF (57) (Fig. B10.13)



The rubber lip (55.1) allows a continuous reinforcement thickness of max. 16 mm.

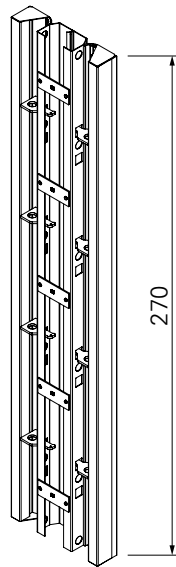


Fig. B10.12a

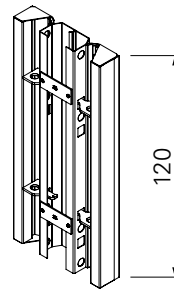


Fig. B10.12b

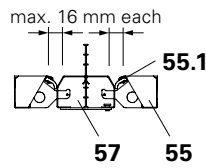


Fig. B10.13

Concrete cover c:

$$c = \frac{d - b}{2} - \varnothing \text{ reinforcement}$$

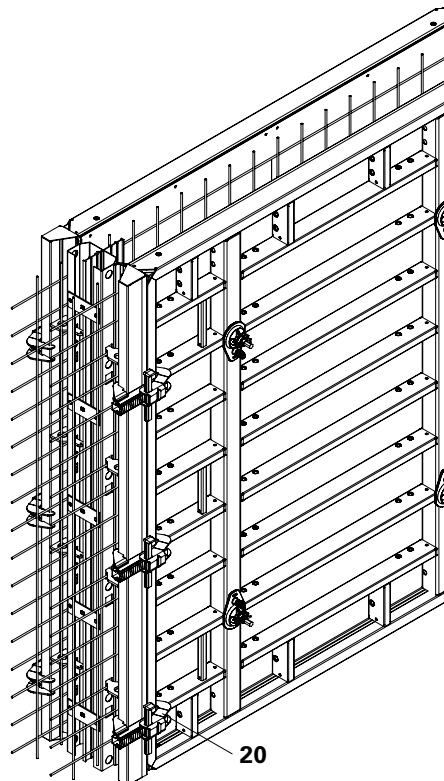


Fig. B10.14

Assembly

1. Position primary formwork.
 2. Fix Outside Piece AT (55) to the primary formwork by means of the Alignment Coupler BFD (20).
 3. Install first row of reinforcement.
 4. Position Centre Piece MTF (57) and install water bar (57.1).
 5. Install second row of reinforcement.
 6. Fix Outside Piece AT to the closing formwork with Alignment Coupler BFD.
 7. Position closing formwork and insert Outer Piece AT into the Centre Piece MTF.
- (Fig. B10.14)

Stopend panel reinforcement with expandable water bar

Consisting of:

- 2x Outside Pieces AT (55)
- Centre Piece MTF (57)
- filler plates (51) supplied by the contractor

(Fig. B10.15 + B10.16)

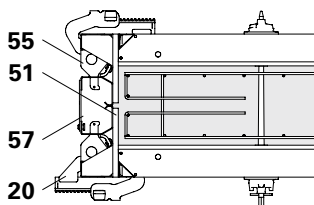


Fig. B10.16

	b [mm]	Wall thickness d [cm]							
		Concrete cover approx. 25 mm				Concrete cover approx. 50 mm			
		20	24/25	30	35	24/25	30	35	40
H = 2,70 m									
AT 270x3	-	2	2	2	2				
AT 270x5	-					2	2	2	2
		without water bar				without water bar			
MT 270x20	118	1				1			
MT 270x24/25	158		1				1		
MT 270x30	218			1				1	
MT 270x35/36	268				1				1
		with water bar				with water bar			
MTF 270x20	118	1				1			
MTF 270x24/25	158		1				1		
MTF 270x30	218			1				1	
MTF 270x35/36	268				1				1

H = 1,20 m									
	b [mm]	Concrete cover approx. 25 mm				Concrete cover approx. 50 mm			
		20	24/25	30	35	24/25	30	35	40
AT 120x3	-	2	2	2	2				
AT 120x5	-					2	2	2	2
		without water bar				without water bar			
MT 120x20	118	1				1			
MT 120x24/25	158		1				1		
MT 120x30	218			1				1	
MT 120x35/36	268				1				1
		with water bar				with water bar			
MTF 120x20	118	1				1			
MTF 120x24/25	158		1				1		
MTF 120x30	218			1				1	
MTF 120x35/36	268				1				1

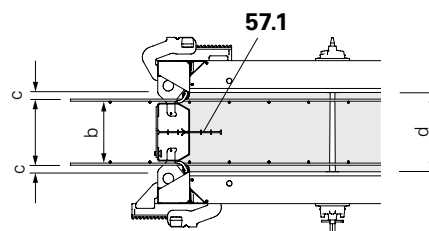


Fig. B10.15

Extension guidelines

Horizontal pre-assembly
up to H 5.40 m



Warning

Risk of injury!

⇒ Swivel nuts of the tie points must be mounted on the primary formwork!

Panel connections

For height extension units

- H = 5.40 m, mount Alignment Couplers BFD (20) on the panel joints 270 – 270. (Fig. B11.01a + B11.01b + B11.01c)
- H ≤ 4.80 m, mount Alignment Couplers BFD (20) on panel joints 270 – 120 and 120 – 90. (Fig. B11.01d)

Assembly information

- The assembly surface must be level.
- Place timbers or planks in position as support.
- Pre-assemble extension units in a horizontal position, with the formlining facing downwards.



For additional extension possibilities, number and arrangement of Alignment Coupler BFD, Compensation Waler MAR 85-3 as well Tie MX 15 – see MAXIMO poster.

Erection with the crane

(Fig. B10.02)



Warning

Risk of injury!

- ⇒ Do not exceed the permissible load-bearing capacity of the Lifting Hook MAXIMO and the crane capacity!
- ⇒ Observe the Instructions for Use for the Lifting Hook MAXIMO 1.5 t!

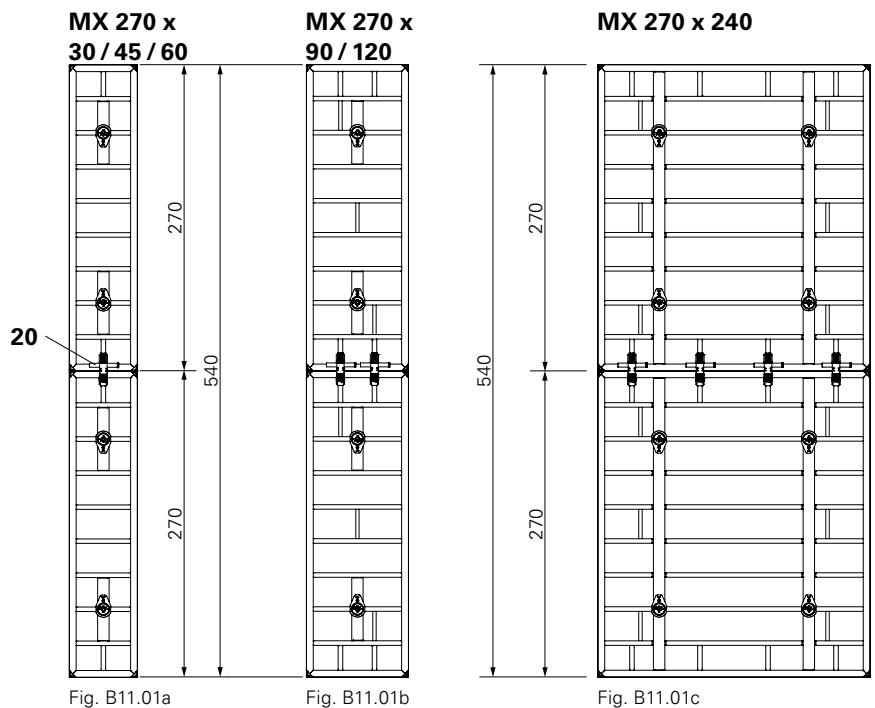


Fig. B11.01a

Fig. B11.01b

Fig. B11.01c

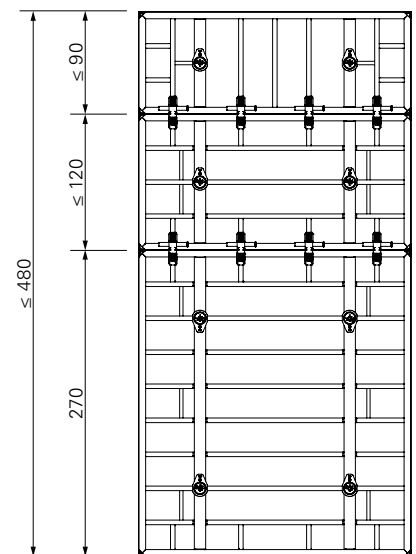


Fig. B11.01d

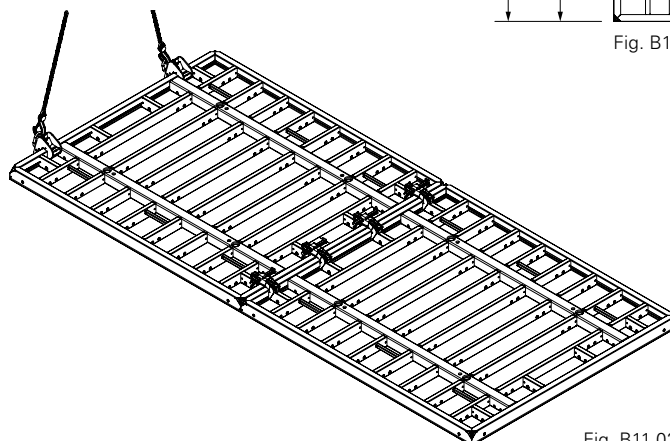


Fig. B11.02

Horizontal pre-assembly up to H 8.10 m



Warning

Risk of injury!

⇒ Swivel nuts of the tie points must be mounted on the primary formwork!

Panel connections

For height extension units

- H = 8.10 m (Fig. B11.03a + B11.03b)
 - On panel joint 270 – 270, install Alignment Coupler BFD (20) and Compensation Waler MAR 85 (21).
 - On panel joint 270 – 60, install Alignment Coupler BFD (20).
- H ≤ 6.60 m
 - On panel joints 240 – 240 and 240 – 120, install Alignment Couplers BFD (20) and Compensation Walers MAR 85 (21),
 - On panel joint 120 – 60, install Alignment Coupler BFD (20). (Fig. B11.03c)

Assembly information

- The assembly surface must be level.
- Place timbers or planks in position as support.
- Pre-assemble extension units in a horizontal position, with the formlining facing downwards.

MX 270 x 60 / 90 / 120

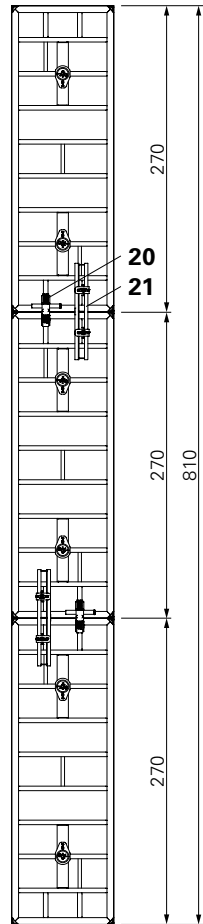


Fig. B11.03a

MX 270 x 240

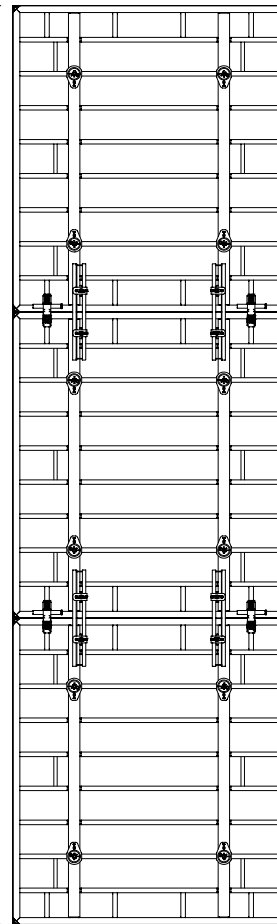


Fig. B11.03b

**MX 270 x 240
Horizontal panels**

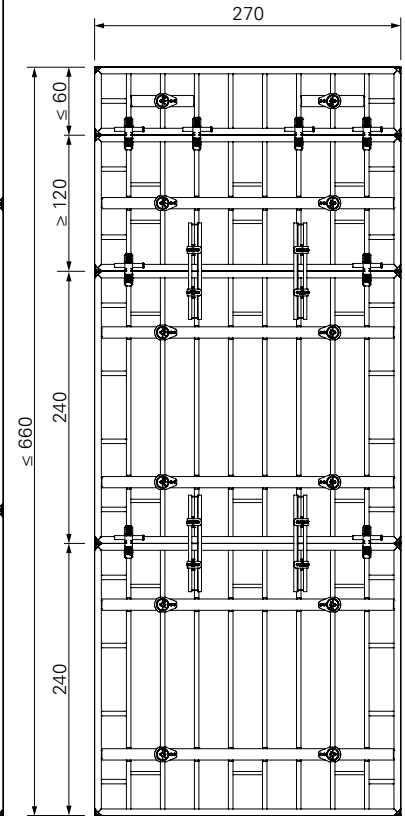


Fig. B11.03c

Erection with the crane

(Fig. B10.04)



Warning

Risk of injury!

- ⇒ Do not exceed the permissible load-bearing capacity of the Lifting Hook MAXIMO and the crane capacity!
- ⇒ Observe the Instructions for Use for the Lifting Hook MAXIMO 1.5 t!

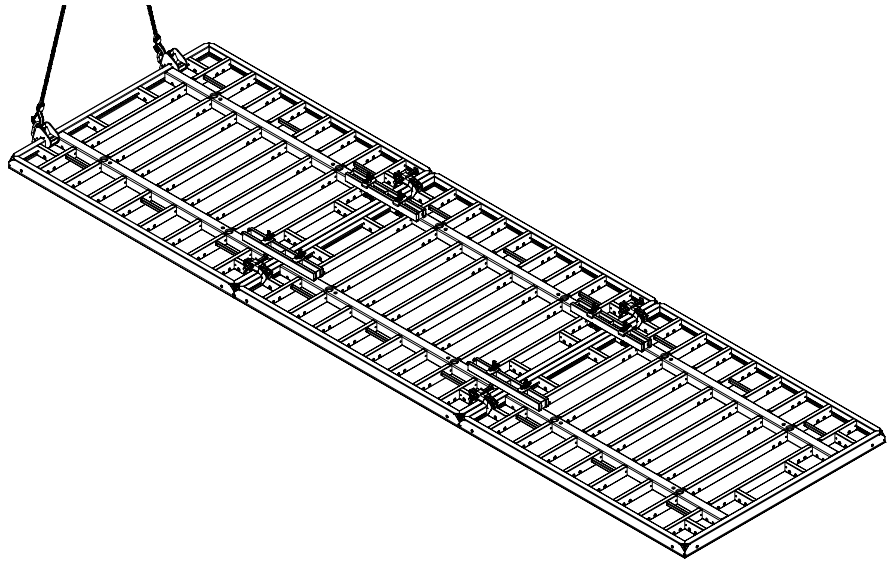


Fig. B11.04

Shaft Corner MXSE 270

Two Shaft Corners MXSE 270 and two Inside Corners MXI 270 x 50/20

Internal shaft wall

Pos. Components

20	Alignment Coupler BFD
82	Shaft Corner MXSE 270
101	Panel MX 270 x 30
103	Panel MX 270 x 60
104	Panel MX 270 x 90
140	Wall Thickness Compensator WDA 270 x width
153	Inside Corner MXI 270 x 50/20

Arrangement of the Alignment Couplers BFD

Shown:

- Shaft dimensions: 2.30 m x 2.60 m
 - Wall thickness 25 cm
- (Fig. B12.01)

Shaft Corner MXSE 270 (82)
(Fig. B12.01a)

Inside Corner MXI 270 x 50/20 (153)
(Fig. B12.01b)

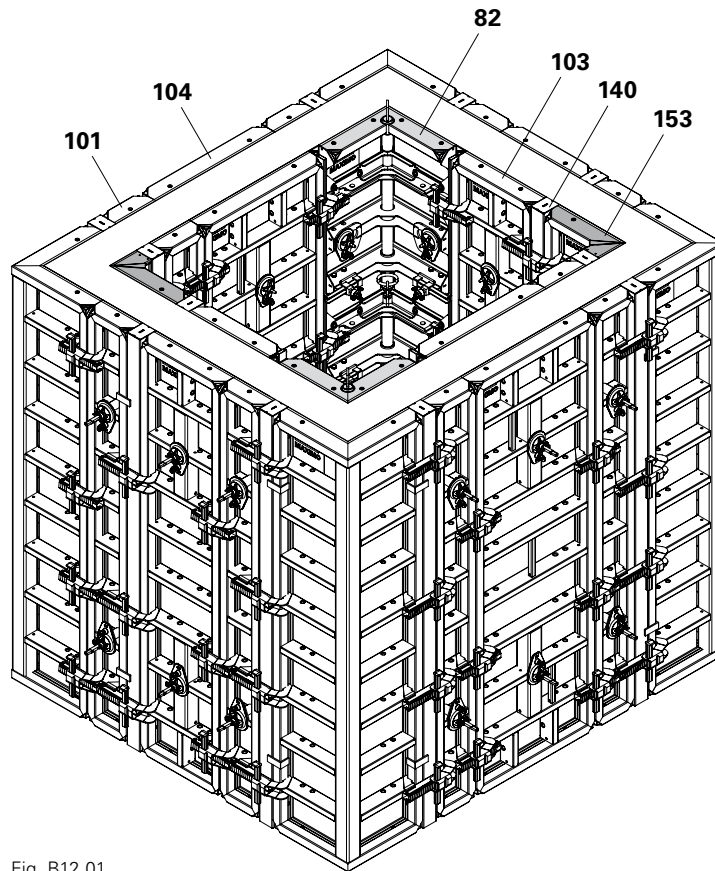


Fig. B12.01

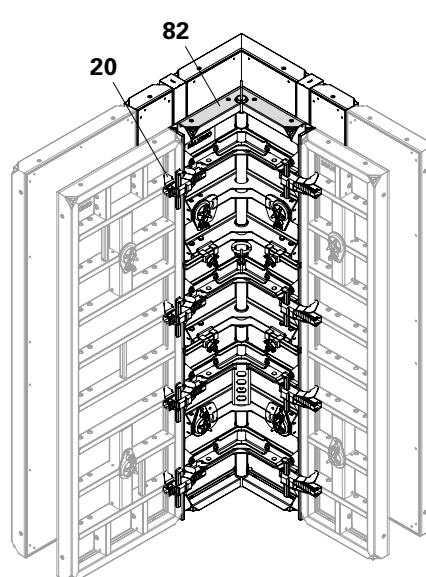


Fig. B12.01a

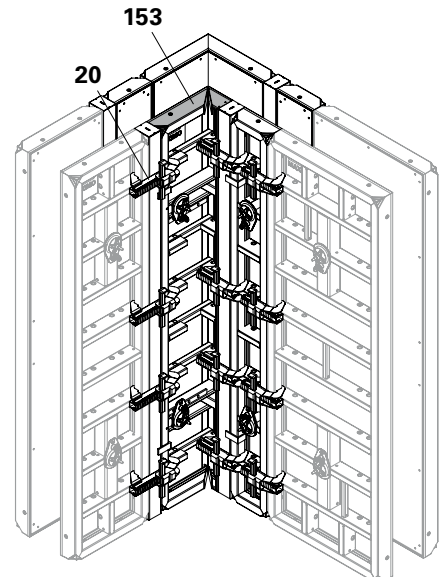


Fig. B12.01b

Four Shaft Corners MXSE 270

Internal shaft wall

Pos. Components

20	Alignment Coupler BFD
82	Shaft Corner MXSE 270
105	Panel MX 270 x 120

Arrangement of the Alignment Couplers BFD

Shown:

- Shaft dimensions: 2.90 x 2.90 m
 - Wall thickness 25 cm
- (Fig. B12.02)

Shaft Corner MXSE 270 (82)
(Fig. B12.02a)

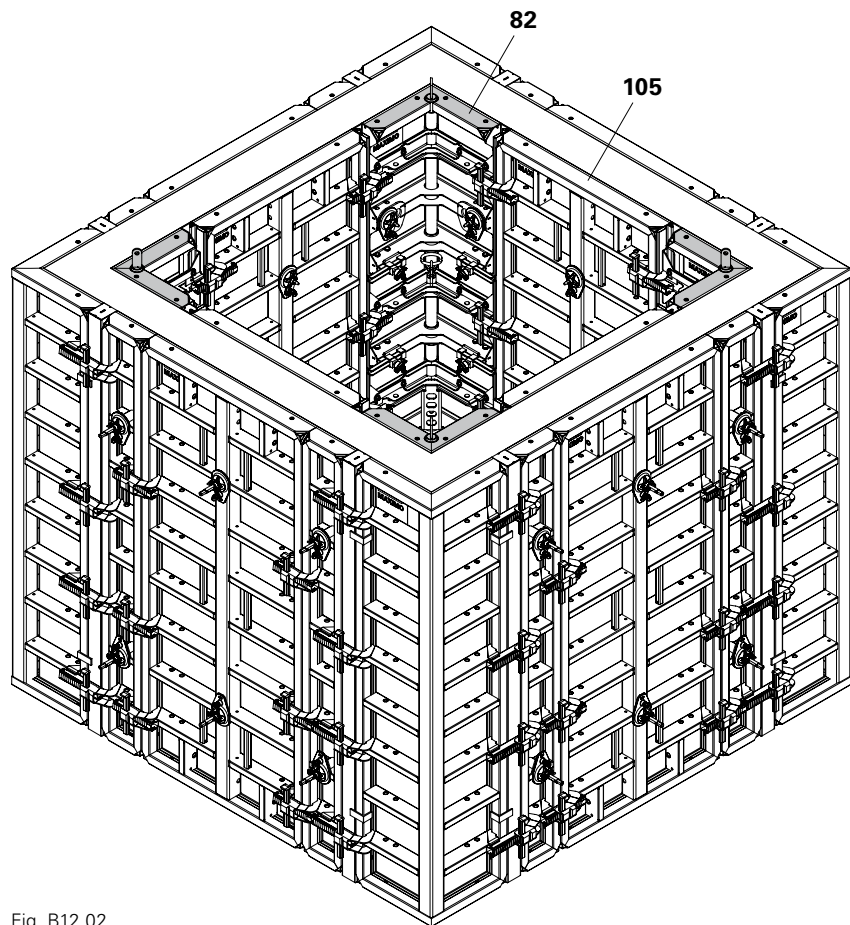


Fig. B12.02

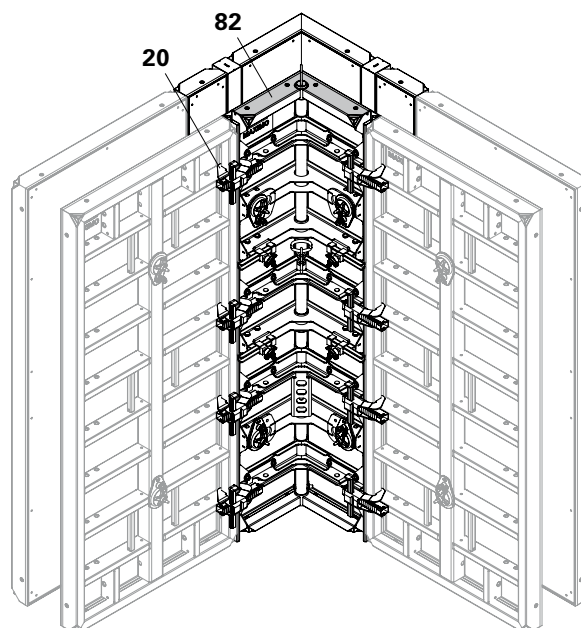


Fig. B12.02a

Wall thicknesses 15 – 40 cm Outside Corner MXA 330 x 45



Perm. fresh concrete pressure 80 kN/m²

Pos. Components

- 20** Alignment Coupler BFD
- 120** Multi Panel
MXM 330 x 60
- 121** Panel MX 330 x 30
- 122** Panel MX 330 x 45
- 142** Wall Thickness Compensator
WDA MX 330 x width or filler
timber
- 159** Outside Corner MXA 330 x 45
- 161** Inside Corner MXI 330 x 50/20

Examples

- WD* 15 cm: Fig. C1.01
- WD 17.5 cm: Fig. C1.02
- WD 20 cm: Fig. C1.03
- WD 24/25 cm: Fig. C1.04
- WD 30 cm: Fig. C1.05
- WD 35/36 cm: Fig. C1.06
- WD 40 cm: Fig. C1.07

Compensations

- Wall thickness 25 + 40 cm: without compensation
- Wall thickness 15 + 17.5 + 24 cm: internal and external compensation
- Wall thickness 20 cm: internal compensation
- Wall thickness 30 + 35/36 cm: external compensation

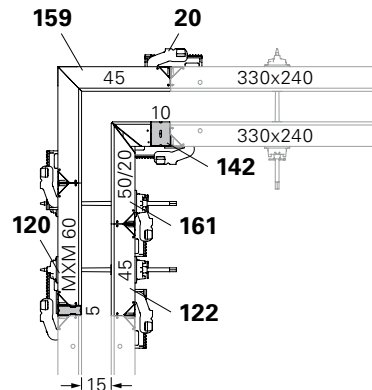


Fig. C1.01

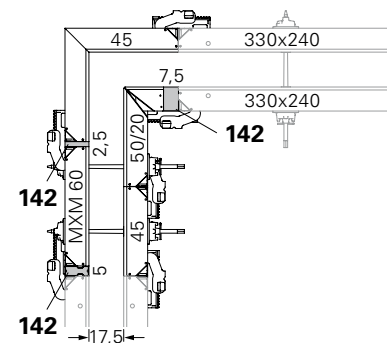


Fig. C1.02

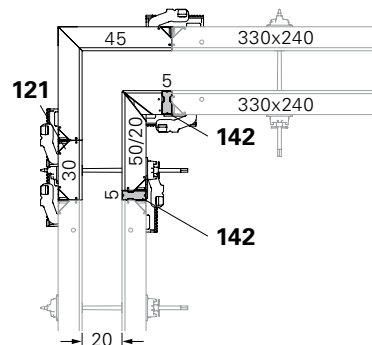


Fig. C1.03

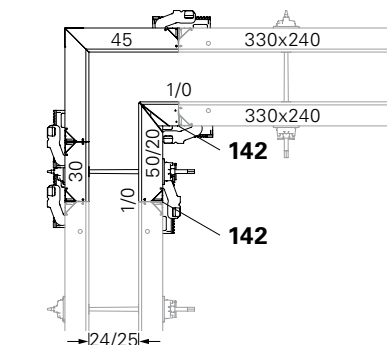


Fig. C1.04

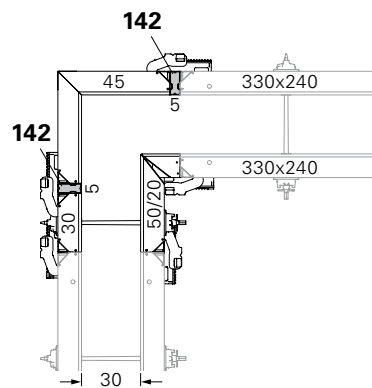


Fig. C1.05

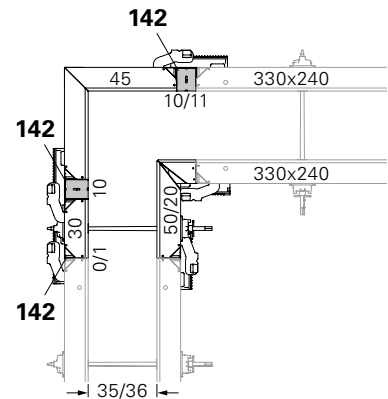


Fig. C1.06



Max. panel width between corner and subsequent panel is 45 cm – Panel MX 330 x 45 (102). (Fig. C1.08)

*WD = wall thickness

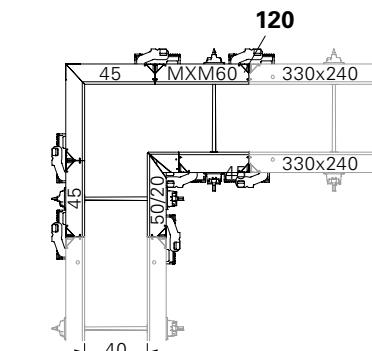


Fig. C1.07

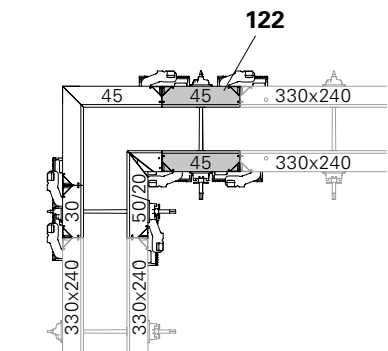


Fig. C1.08

Arrangement of the Alignment Couplers

Valid for wall thicknesses 15 – 40 cm

View of Inside Corner MXI 330 x 50/20
(Fig. C1.09)

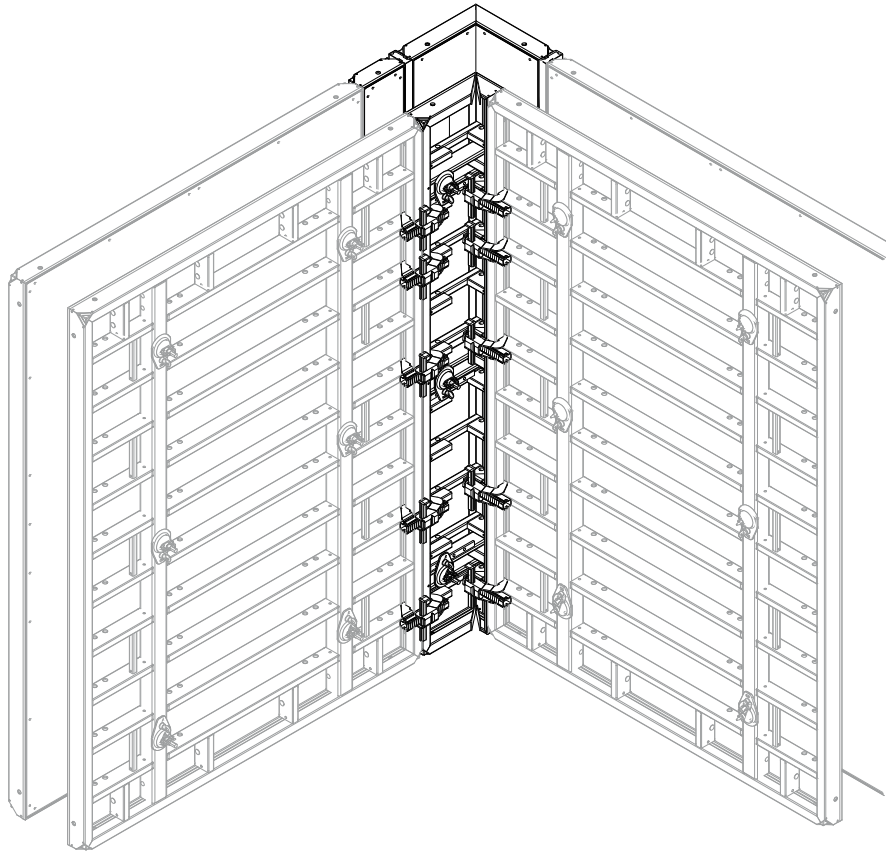


Fig. C1.09

View of Outside Corner MXA 330 x 45
(Fig. C1.10)

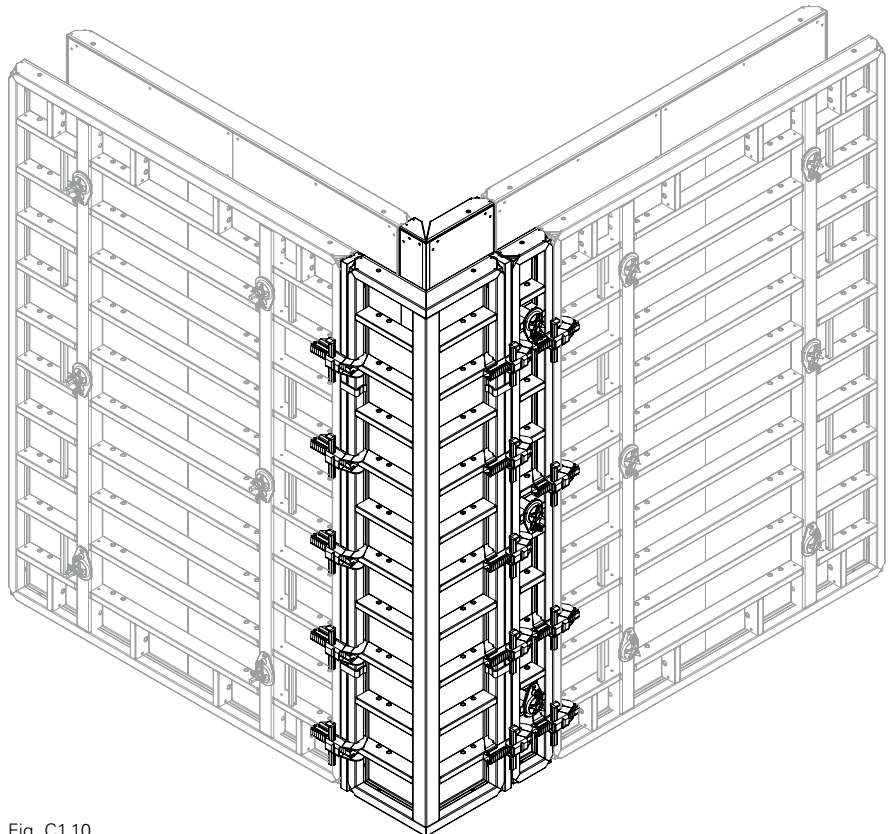


Fig. C1.10

Wall thickness 60 cm

Outside Corner MXA 330 x 45



Perm. fresh concrete pressure: 60 kN/m²

Pos. Components

- 20** Alignment Coupler BFD
- 21** Compensation Waler MAR 85-3
- 22** Compensation Waler MAR 170-3
- 23** Wingnut Pivot Plate DW 15
- 25** Tie Rod DW 15
- 26** Spacer Tube Rough 22
- 120** Multi Panel
MXM 330 x 60
- 121** Panel MX 330 x 30
- 142** Wall Thickness Compensator
WDA MX 330 x width
- 159** Outside Corner MXA 330 x 45
- 161** Inside Corner MXI 330 x 50/20
- 249** Cone MX DR 22/2

Example

View from above (Fig. C1.11 + C1.11a)

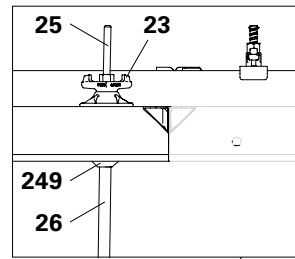


Fig. B1.11a

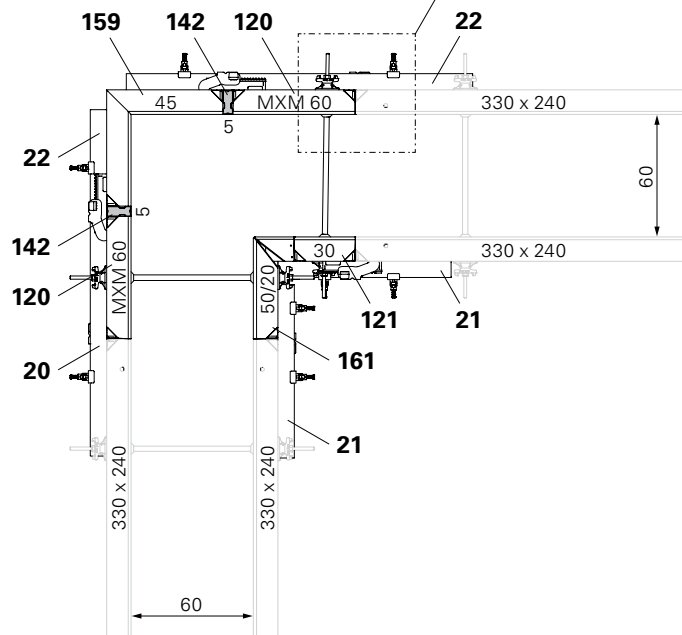


Fig. C1.11

Arrangement of the Alignment Couplers and Steel Walers

View of Inside Corner MXI 330 x 50/20
(Fig. C1.12)

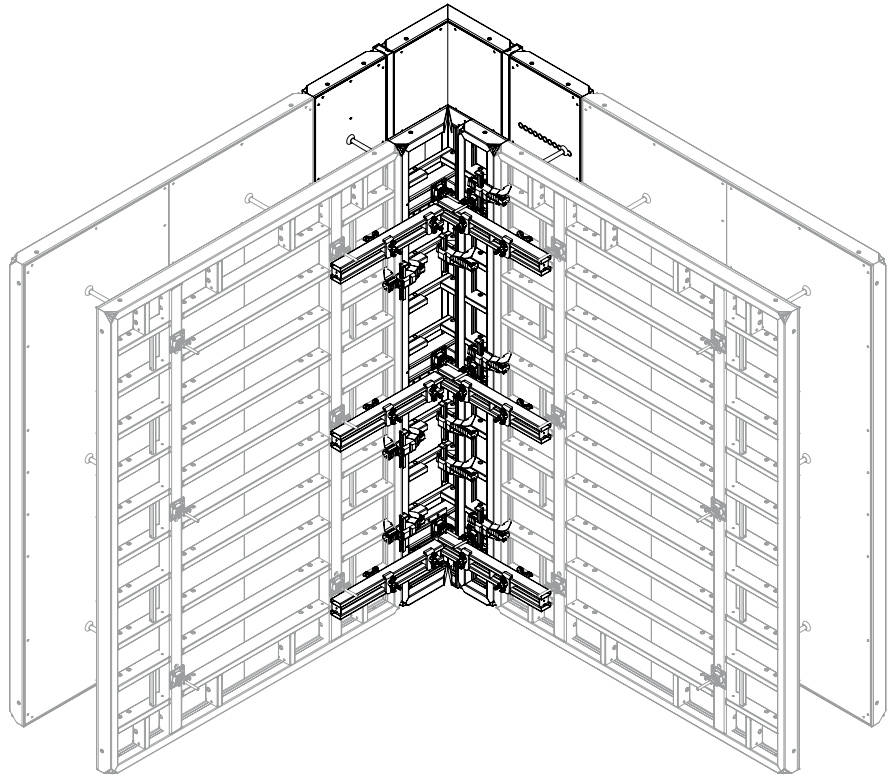


Fig. C1.12

View of Outside Corner MXA 330 x 45
(Fig. C1.13)

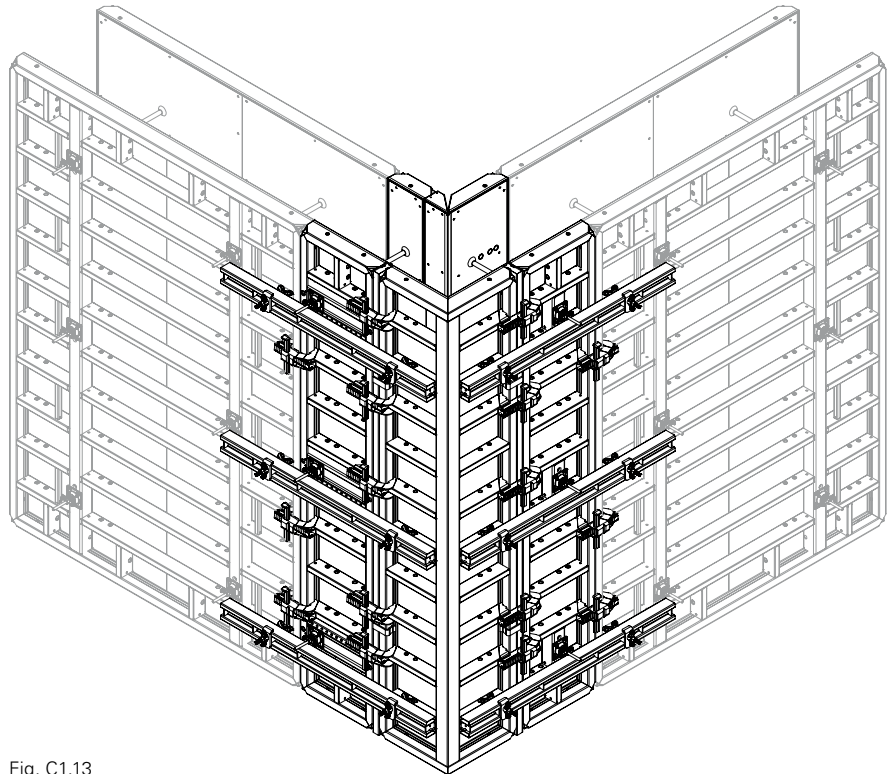


Fig. C1.13

C1 90° corners with Inside Corner MXI 330 x 50/20

Wall thickness 80 cm
Outside Corner MXA 330 x 45



Perm. fresh concrete pressure: 60 kN/m²

Pos. Components

- 19** Waler Stop
- 20** Alignment Coupler BFD
- 21** Compensation Waler MAR 85-3
- 23** Wingnut Pivot Plate DW 15
- 24** Hook Tie DW 15/400
- 25** Tie Rod DW 15
- 29** Steel Waler Universal SRU U120, L = 2.47 m
- 36** Tie Rod DW 20
- 37** Spacer Tube Rough DR 28
- 38** DK Sealing Cone DW 20/55
- 39** Wingnut Pivot Plate DW 20
- 44** Wingnut DW 15
- 49** Tie Yoke SW
- 121** Panel MX 330 x 30
- 123** Panel MX 330 x 60
- 142** Wall Thickness Compensator WDA MX 330 x width or filler timber
- 159** Outside Corner MXA 330 x 45
- 161** Inside Corner MXI 330 x 50/20

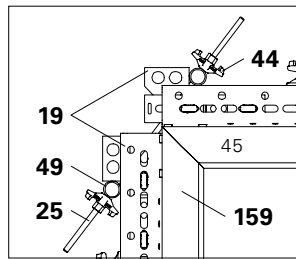


Fig. C1.14a

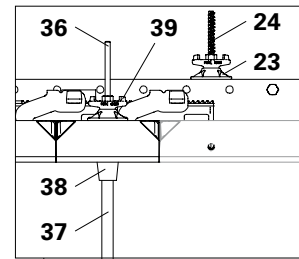


Fig. C1.14b

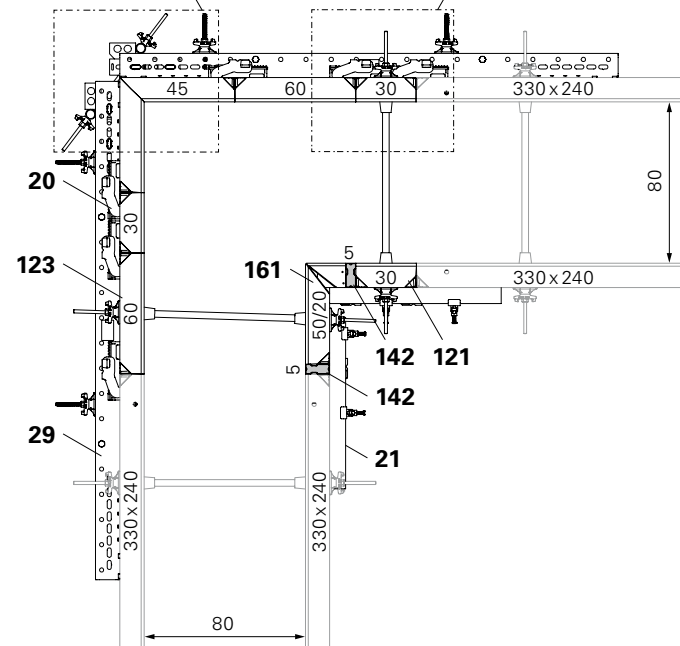


Fig. C1.14

Example

View from above
 (Fig. C1.14 + C1.14a + C1.14b)

Arrangement of the Alignment Couplers and Steel Walers

View of Inside Corner MXI 330 x 50/20
(Fig. C1.15)

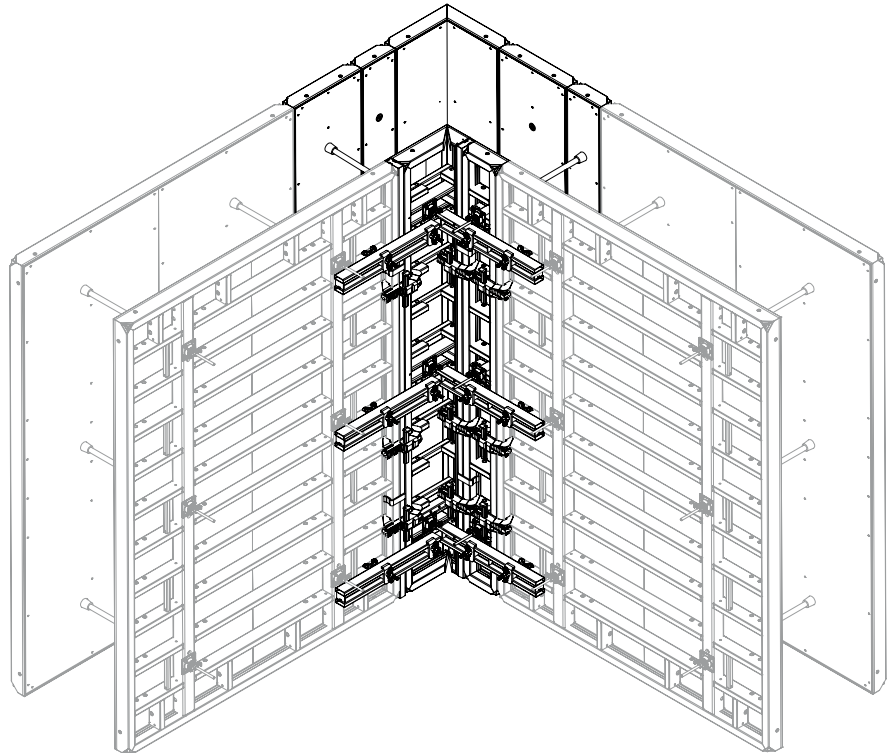


Fig. C1.15

View of Outside Corner MXA 330 x 45
(Fig. C1.16)

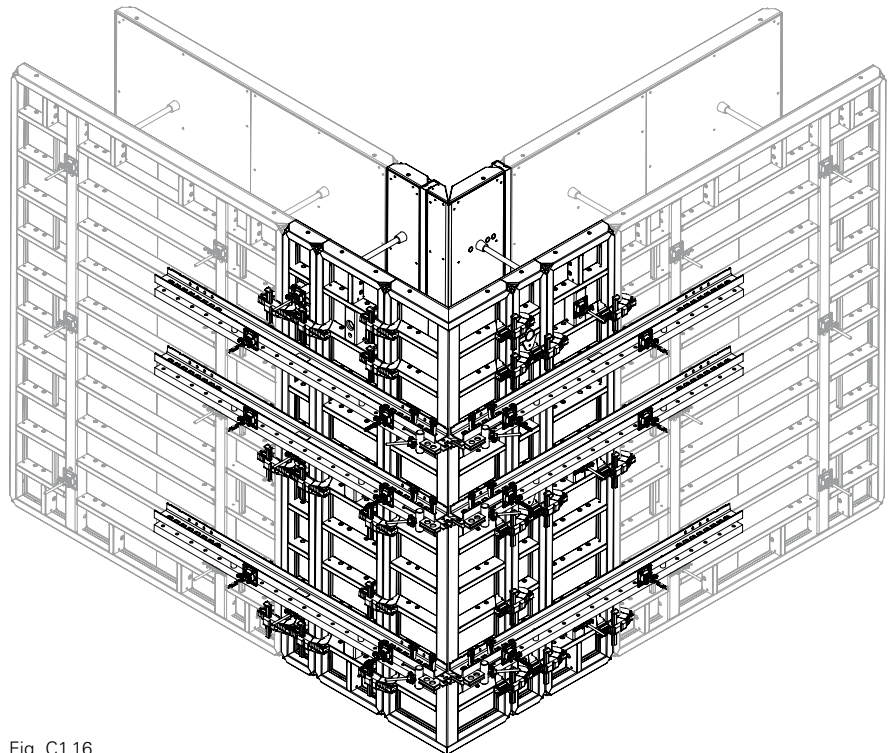


Fig. C1.16

Wall thicknesses 15 – 30 cm External Corner MXA 330 x 35



Perm. fresh concrete pressure: 80 kN/m²

Pos. Components

- 20** Alignment Coupler BFD
- 121** Panel MX 330 x 30
- 122** Panel MX 330 x 45
- 142** Wall Thickness Compensator WDA MX 330 x width or filler timber
- 158** External Corner MXA 330 x 35
- 160** Inside Corner MXI 330 x 60

Examples

- Wall thickness 15: Fig. C2.01
- Wall thickness 17.5: Fig. C2.02
- Wall thickness 20: Fig. C2.03
- Wall thickness 24/25: Fig. C2.04
- Wall thickness 30: Fig. C2.05

Compensations

- Wall thickness 15 + 17.5 cm: external compensation
- Wall thickness 20: without compensation
- Wall thickness 24/25 + 30: external compensation

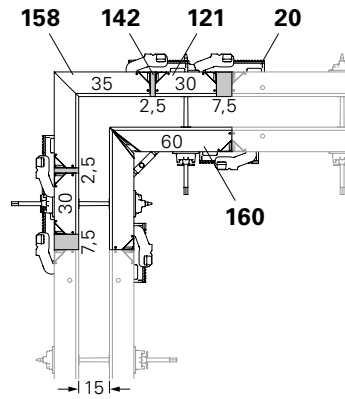


Fig. C2.01

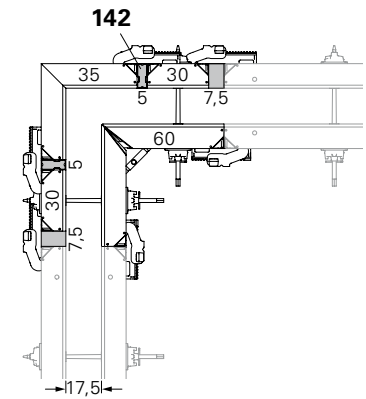


Fig. C2.02

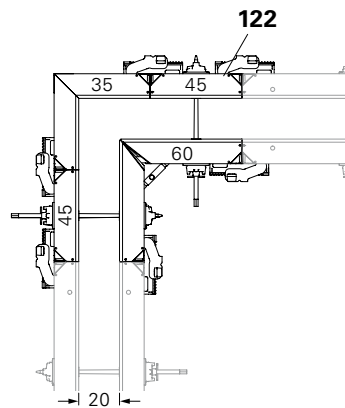


Fig. C2.03

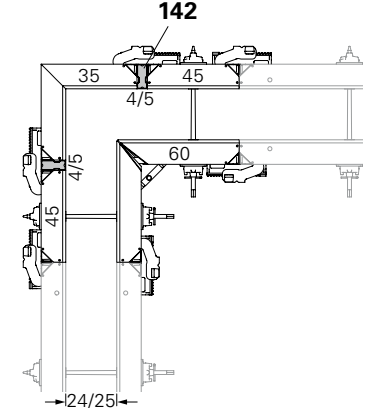


Fig. C2.04

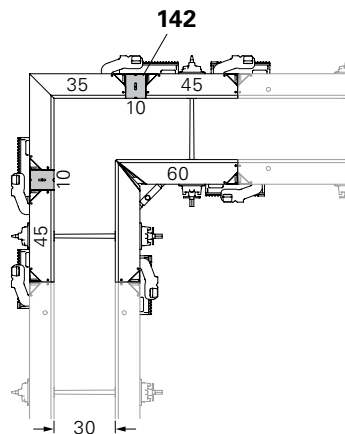


Fig. C2.05

Wall thicknesses 30 – 40 cm Outside Corner MXA 330 x 45



Perm. fresh concrete pressure: 80 kN/m²

Pos. Components

- 20** Alignment Coupler BFD
- 122** Panel MX 330 x 45
- 142** Wall Thickness Compensator
WDA MX 330 x width or filler
timber
- 159** Outside Corner MXA 330 x 45
- 160** Inside Corner MXI 330 x 60

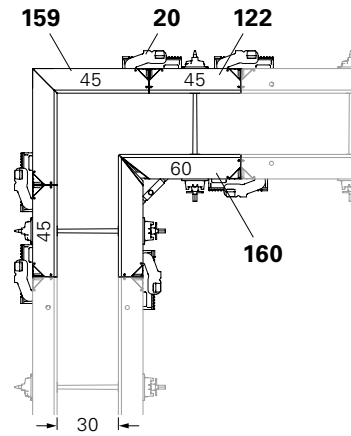


Fig. C2.06

Examples

- Wall thickness 30 cm: Fig. C2.06
- Wall thickness 35 + 36 cm: Fig. C2.07
- Wall thickness 40 cm: Fig. C2.08

Compensations

- Wall thickness 30 cm: without compensation
- Wall thickness 35/36 + 40 cm: external compensation

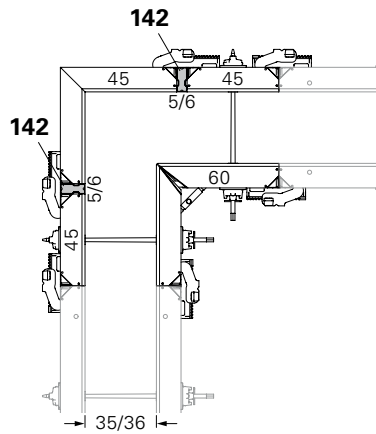


Fig. C2.07

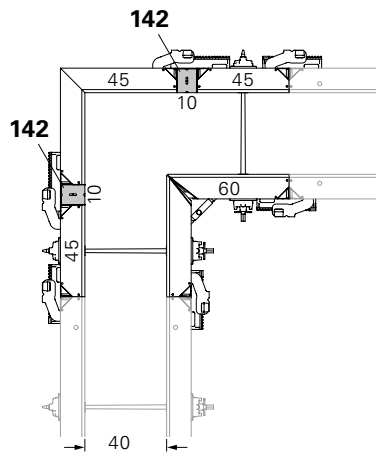


Fig. C2.08

Arrangement of the Alignment Couplers

Valid for wall thicknesses 15 – 40 cm

View of Inside Corner MXI 330 x 60
(Fig. C2.09)

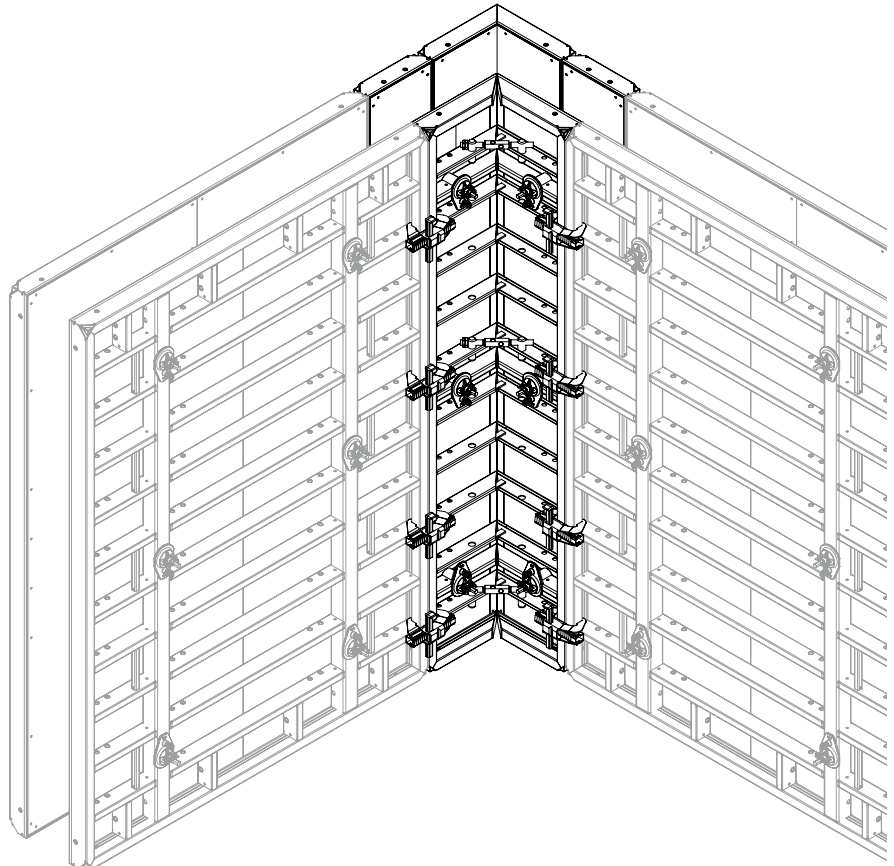


Fig. C2.09

View of Outside Corner MXA 330 x 35
or MXA 330 x 45 (Fig. C2.10)

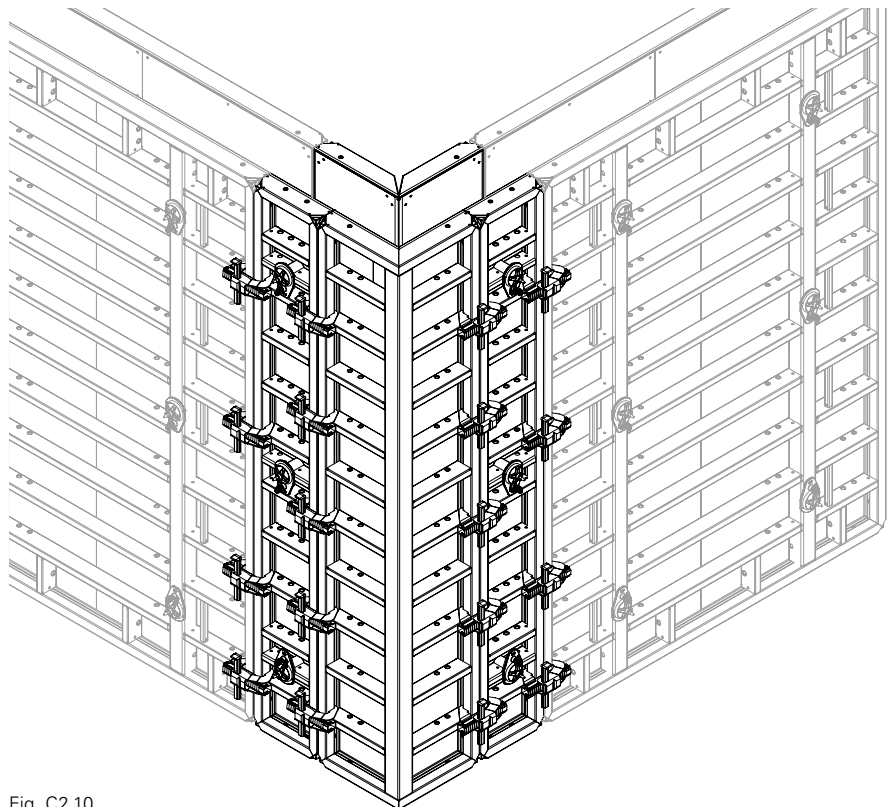


Fig. C2.10

C2 90° corners with Inside Corner MXI 330 x 60

Wall thickness 60 cm

Outside Corner MXA 330 x 45



Perm. fresh concrete pressure: 60 kN/m²

Pos. Components

- 20** Alignment Coupler BFD
- 22** Compensation Waler MAR 170-3
- 23** Wingnut Pivot Plate DW 15
- 25** Tie Rod DW 15
- 26** Spacer Tube Rough 22
- 121** Panel MX 330 x 30
- 122** Panel MX 330 x 45
- 159** Outside Corner MXA 330 x 45
- 160** Inside Corner MXI 330 x 60
- 249** Cone MX DR 22/2

Example

View from above (Fig. C2.11 + C2.11a)

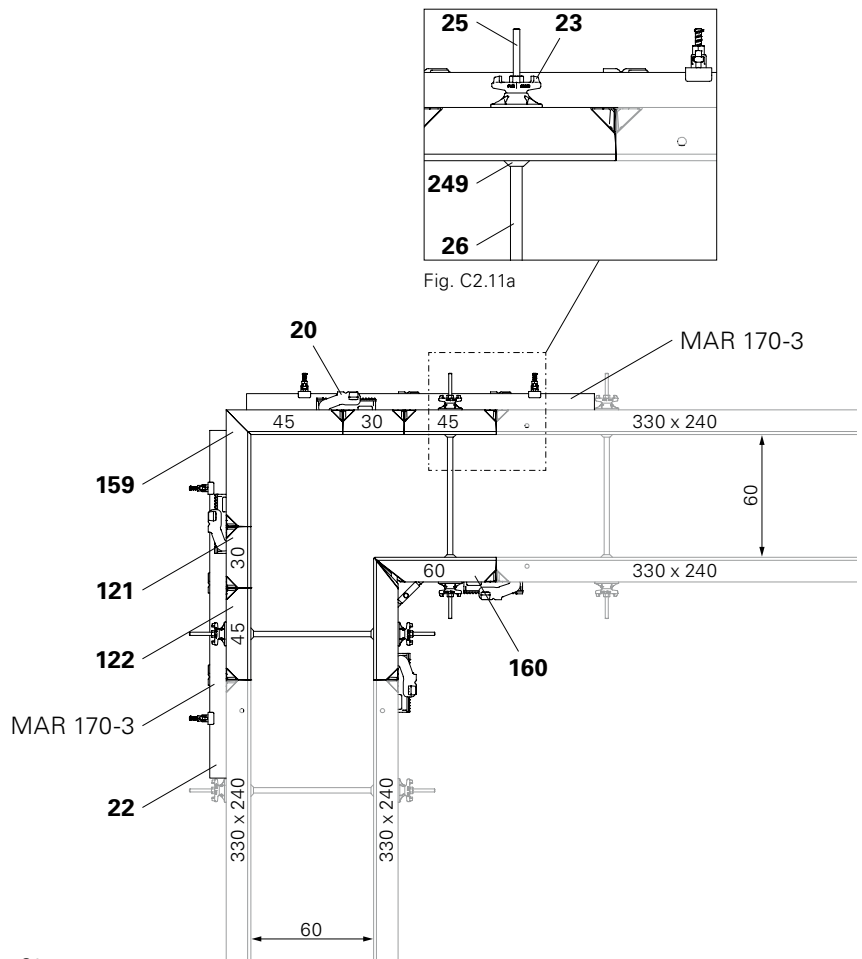


Fig. C2.11

Arrangement of the Alignment Couplers and Steel Walers

View of Inside Corner MXI 330 x 60
(Fig. C2.12)

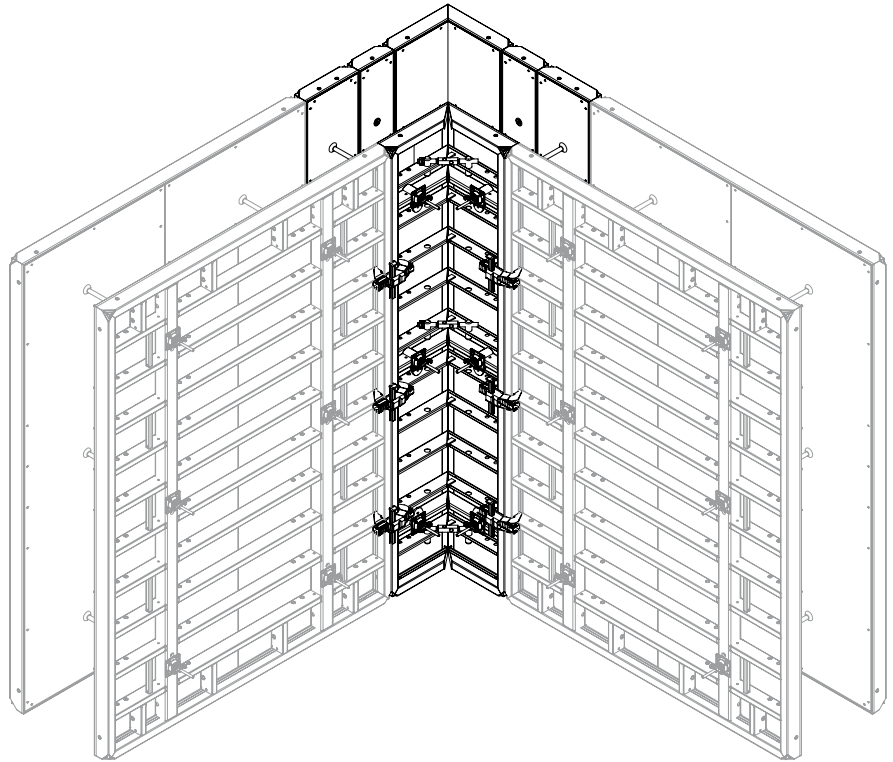


Fig. C2.12

View of Outside Corner MXA 330 x 45
(Fig. C2.13)

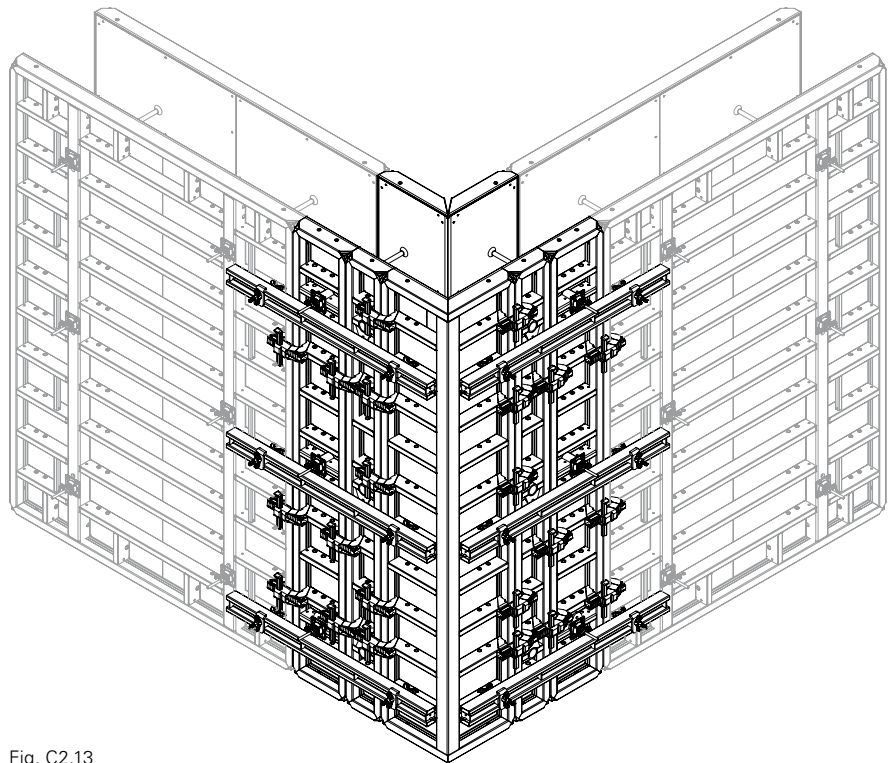


Fig. C2.13

C2 90° corners with Inside Corner MXI 330 x 60

Wall thickness 80 cm

Outside Corner MXA 330 x 45



Perm. fresh concrete pressure: 60 kN/m²

Pos. Components

- 19 Waler Stop
- 20 Alignment Coupler BFD
- 23 Wingnut Pivot Plate DW 15
- 24 Hook Tie DW 15/400
- 25 Tie Rod DW 15
- 29 Steel Waler Universal SRU U120, L = 2.47 m
- 36 Tie Rod DW 20
- 37 Spacer Tube Rough 28
- 38 DK Sealing Cone DW 30/55
- 39 Wingnut Pivot Plate DW 20
- 44 Wingnut DW 15
- 49 Tie Yoke SW
- 122 Panel MX 330 x 45
- 142 Wall Thickness Compensator WDA MX 330 x width or filler timber
- 159 Outside Corner MXA 330 x 45
- 160 Inside Corner MXI 330 x 60

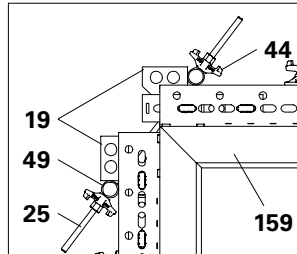


Fig. C2.14a

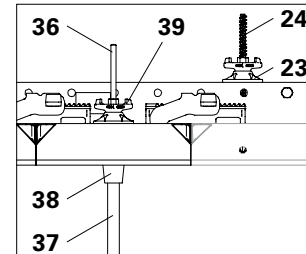


Fig. C2.14b

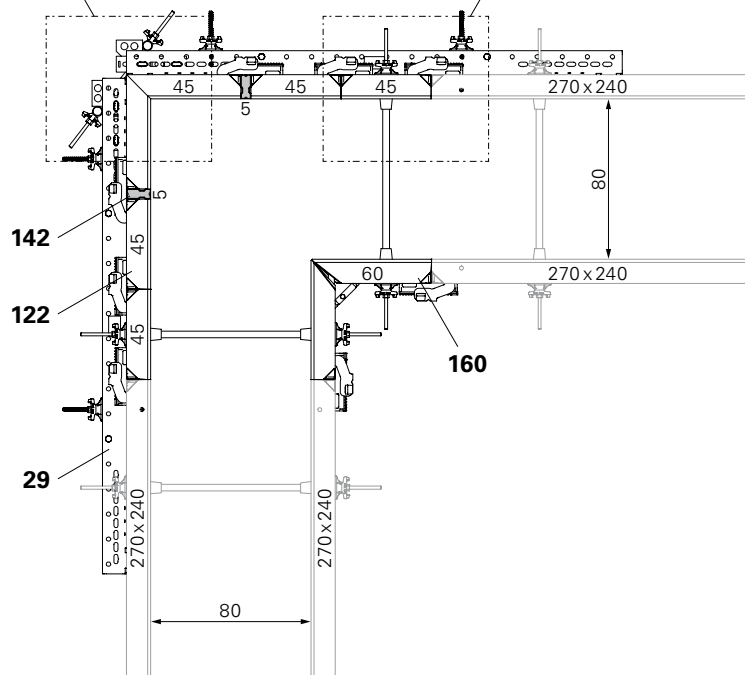


Fig. C2.14

Example

View from above
(Fig. C2.14 + C2.14a + C2.14b)

Arrangement of the Alignment Couplers and Steel Walers

View of Inside Corner MXI 330 x 60
(Fig. C2.15)

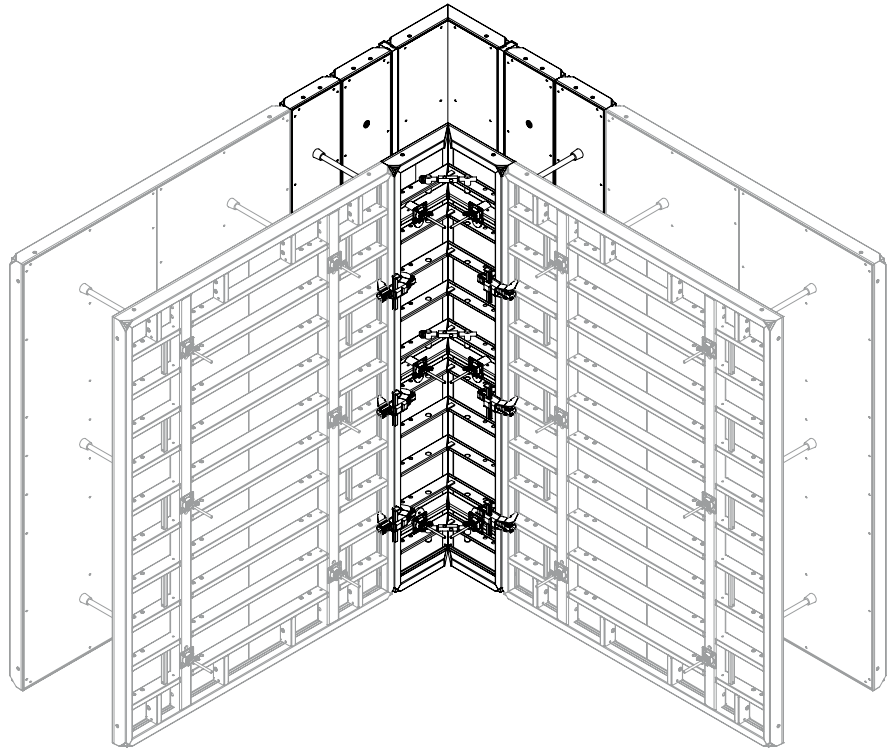


Fig. C2.15

View of Outside Corner MXA 330 x 45
(Fig. C2.16)

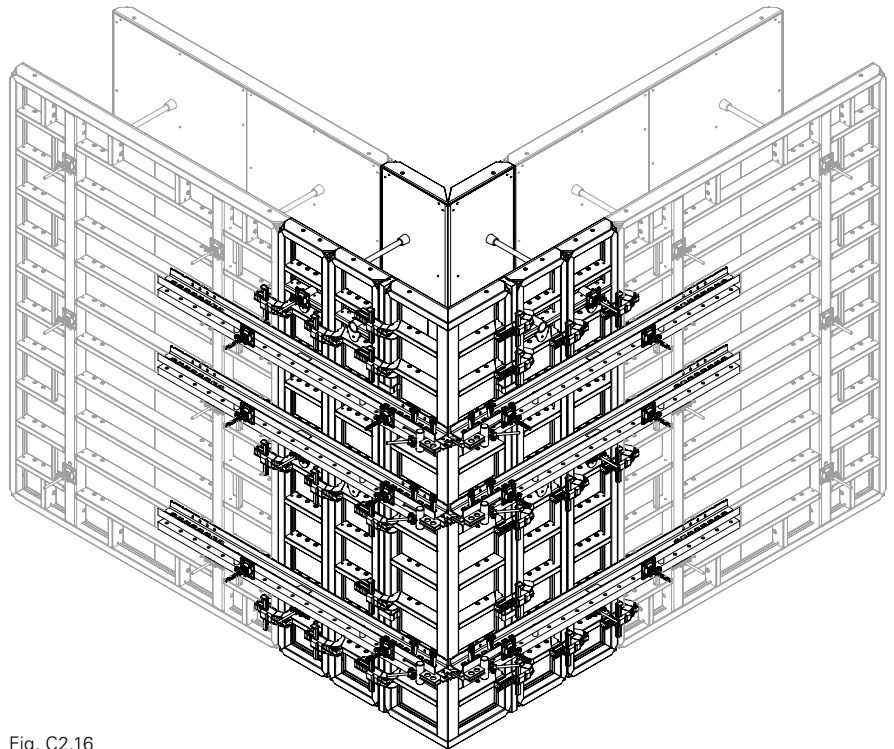


Fig. C2.16

C3 Panel connections following 90° corners

Panel connections

With 90° corners, these must be strengthened at the next panel joint by means of a Compensation Waler MAR 85 (21).

This applies to panels with widths $b \leq 120$.

With extensions, a second Compensation Waler MAR 85 (21) is required on the panel joint (shown as a dotted line). (Fig. C3.02 + C3.03)

Pos.	Components	Item no.
20	Alignment Coupler BFD	023500
21	Compensation Waler MAR 85-3	124941

Example

View from above (Fig. C3.01)

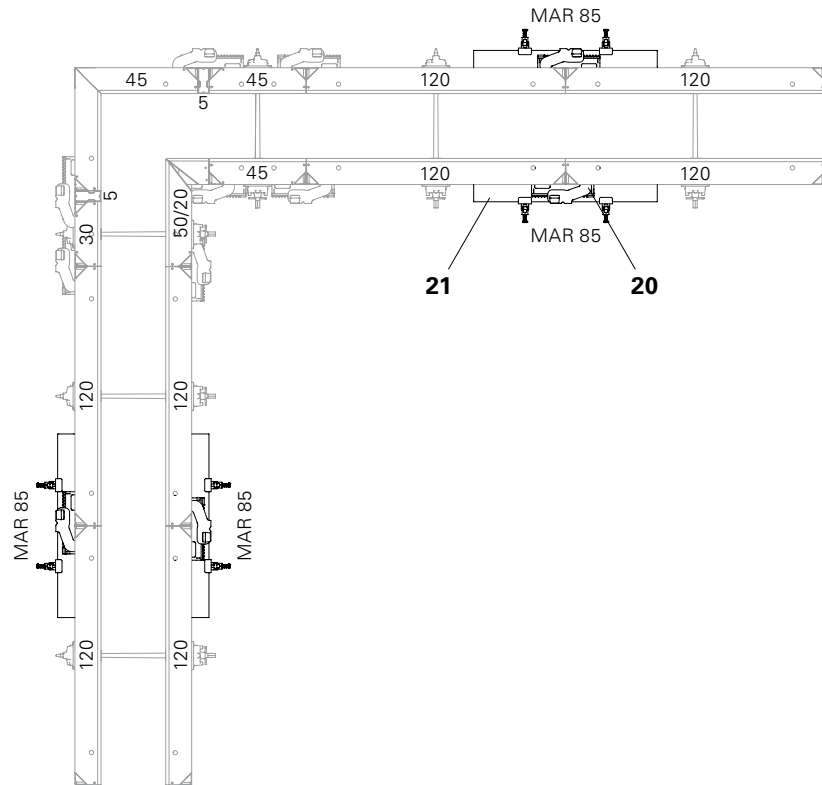


Fig. C3.01

C3 Panel connections following 90° corners

Arrangement of the Alignment Couplers and Steel Walers

View of Inside Corner MXI 330 x 60
(Fig. C3.02)

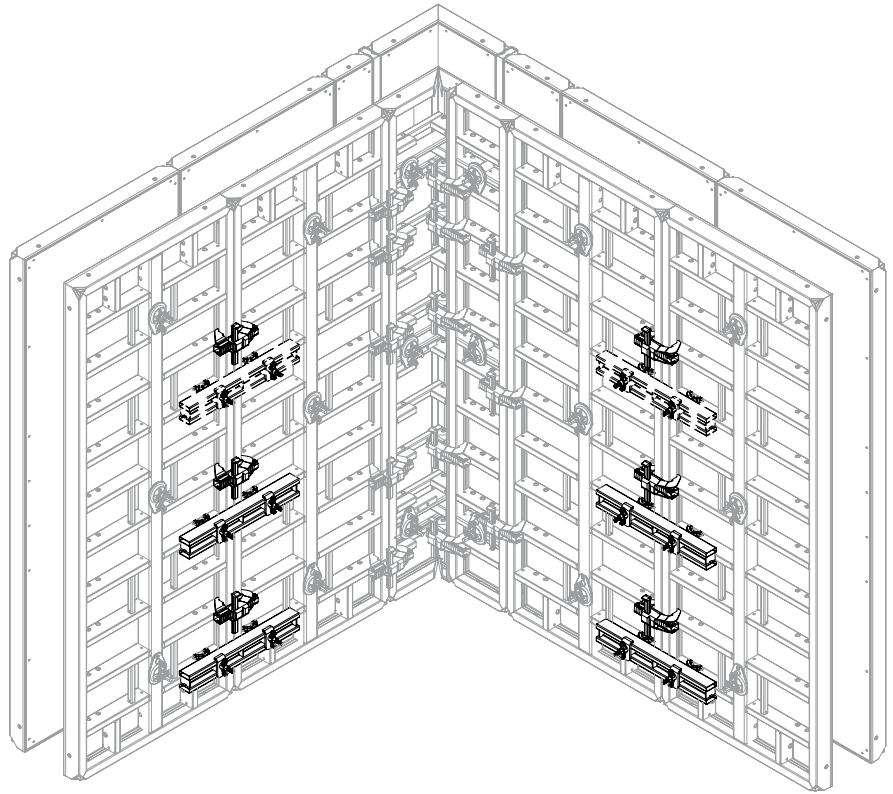


Fig. C3.02

View of Outside Corner MXA 330 x 45
(Fig. C3.03)

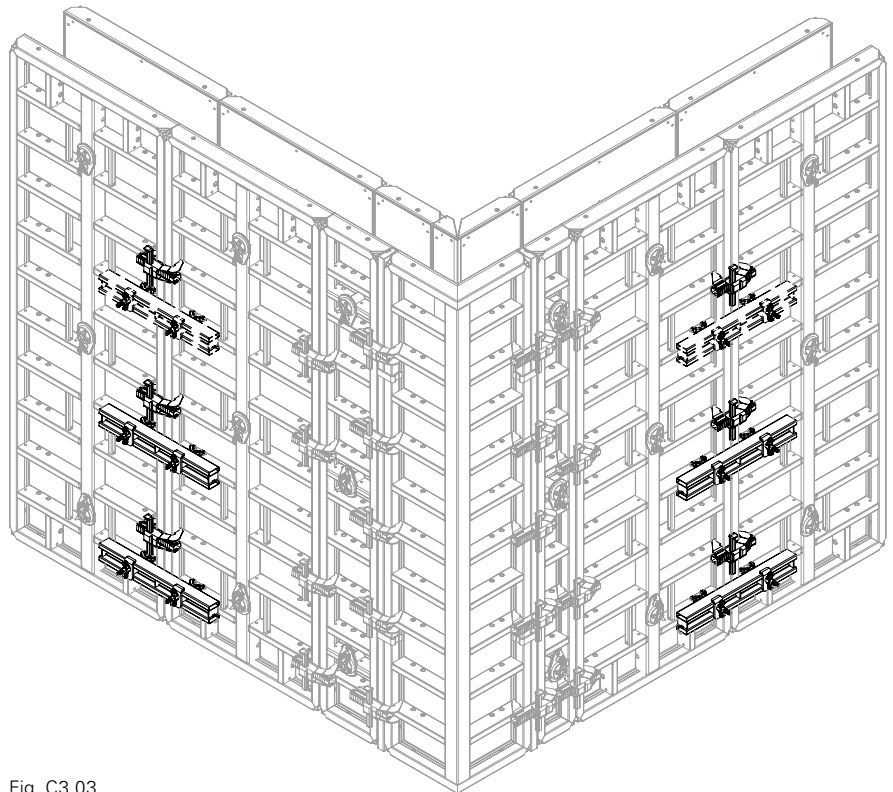


Fig. C3.03

C4 90° T-junctions with Inside Corner MXI 330 x 50/20

Wall thicknesses 15 – 40 cm



Perm. fresh concrete pressure 80 kN/m²

Pos. Components

- 20** Alignment Coupler BFD
- 120** Multi Panel
MXM 330 x 60
- 122** Panel MX 330 x 45
- 123** Panel MX 330 x 60
- 142** Wall Thickness Compensator
WDA MX 330 x width or filler
timber
- 161** Inside Corner MXI 330 x 50/20

Assembly

1. Form the T-junction with Inside Corner MXI 330 x 50/20 (161).
2. Form the opposing straight wall with Panel MX 330 x 45 (122), MX 330 x 60 (123) or MXM 330 x 60 (120) depending on the wall thickness.
3. Install Wall Thickness Compensator WDA (142) – according to the wall thickness.

Examples

- Wall thickness 15: Fig. C4.01
- Wall thickness 17.5: Fig. C4.02
- Wall thickness 20: Fig. C4.03
- Wall thickness 24/25: Fig. C4.04
- Wall thickness 30: Fig. C4.05
- Wall thickness 35/36: Fig. C4.06
- Wall thickness 40: Fig. C4.07

Compensations

- Wall thickness 15 + 17.5 + 24/25 cm: external compensation
- Wall thickness 30 + 35/36 + 40 cm: external compensation
- Wall thickness 20: without compensation



Max. panel width at T-junction between the corner and subsequent panel is 45 cm – MX 330 x 45 (122). (Fig. B4.08)

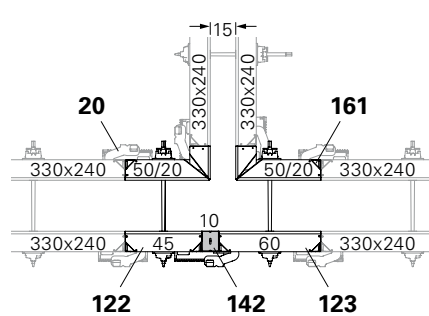


Fig. C4.01

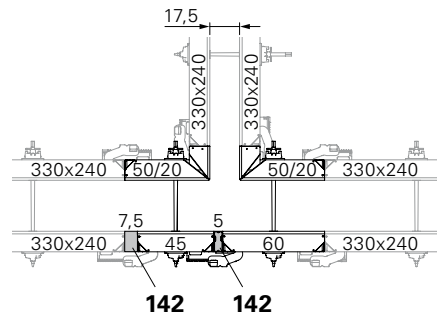


Fig. C4.02

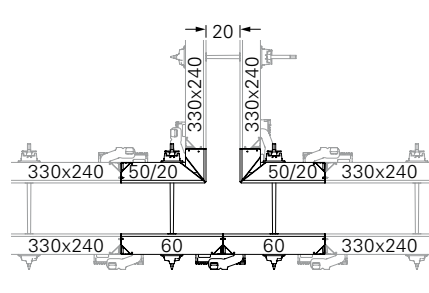


Fig. C4.03

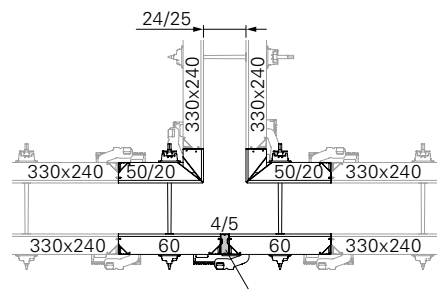


Fig. C4.04

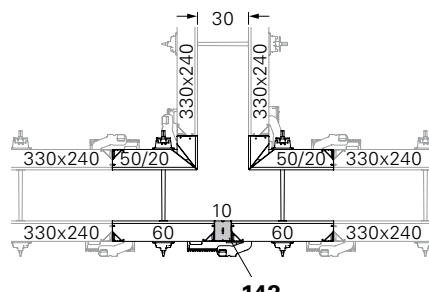


Fig. C4.05

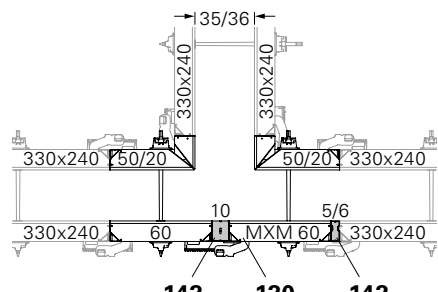


Fig. C4.06

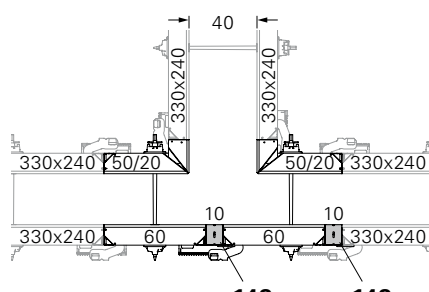


Fig. C4.07

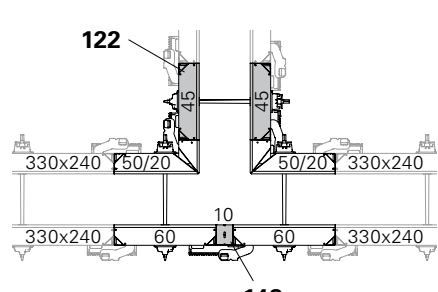


Fig. C4.08

C4 90° T-junctions with Inside Corner MXI 330 x 50/20

Arrangement of the Alignment Couplers

Valid for wall thicknesses 15 – 40 cm
(Fig. C4.09 + C4.10)

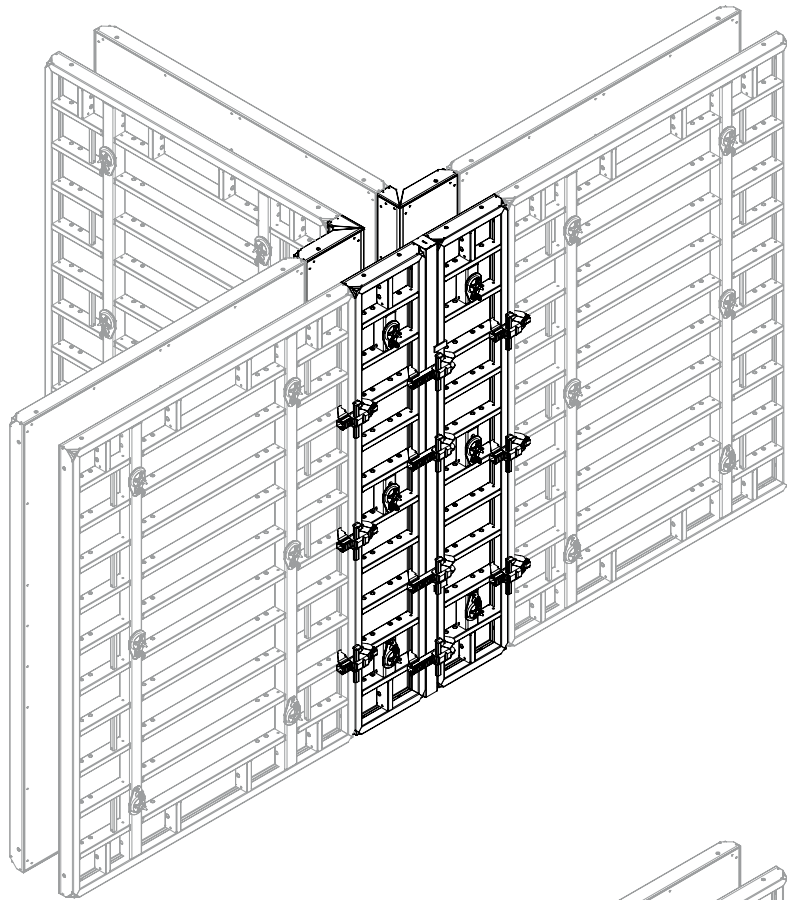


Fig. C4.09

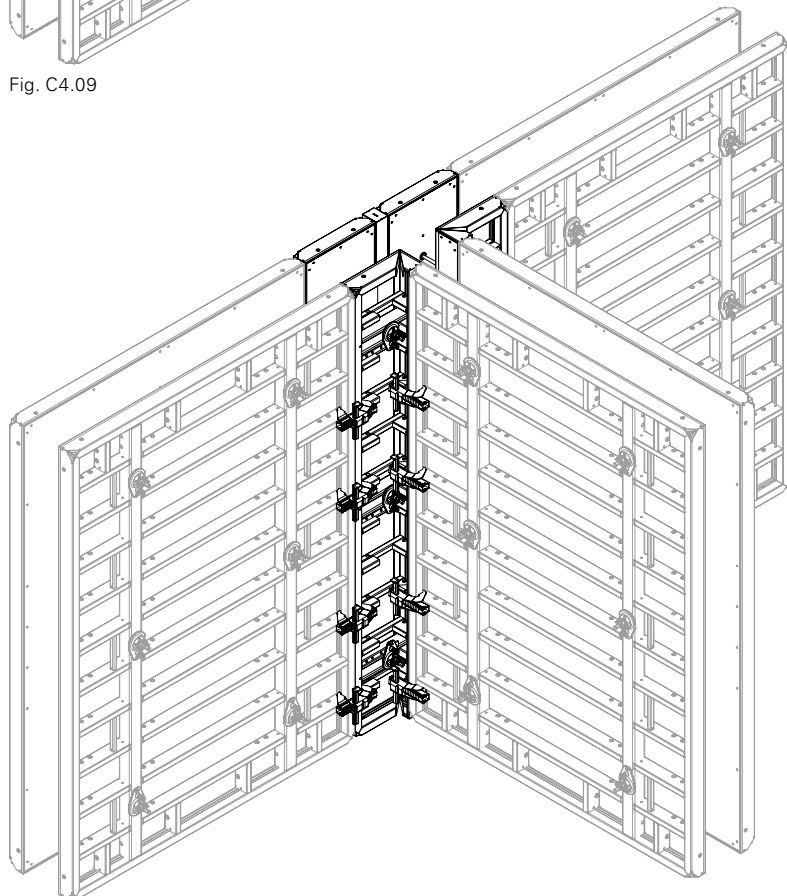


Fig. C4.10

Wall thicknesses 15 – 40 cm



Perm. fresh concrete pressure 80 kN/m²

Pos. Components

- 20** Alignment Coupler BFD
- 22** Compensation Waler MAR 170-3
- 122** Panel MX 330 x 45
- 123** Panel MX 330 x 60
- 142** Wall Thickness Compensator WDA MX 330 x width or filler timber
- 160** Inside Corner MXI 330 x 60

Assembly

1. Form the T-junction with Inside Corner MXI 330 x 60 (160).
2. Form the opposing straight wall with Panel MX 330 x 45 (122) or MX 330 x 60 (123).
3. Install one Panel MX 330 x 45 (122) each on the right and left.
4. Install Wall Thickness Compensator (142) – according to the wall thickness.
5. On the straight wall, install Compensation Waler MAR 170 (22) centrally to the outgoing wall.

Examples

- Wall thickness 15: Fig. C5.01
- Wall thickness 17.5: Fig. C5.02
- Wall thickness 20: Fig. C5.03
- Wall thickness 24/25: A Fig. C5.04
- Wall thickness 30: Fig. C5.05
- Wall thickness 35/36: Fig. C5.06
- Wall thickness 40: Fig. C5.07

Compensations

- Wall thickness 15 + 30: without compensation
- Wall thickness 17.5 + 20 + 24/25 + 35/36 + 40 cm: external compensation

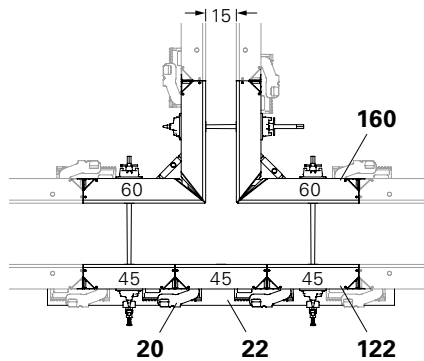


Fig. C5.01

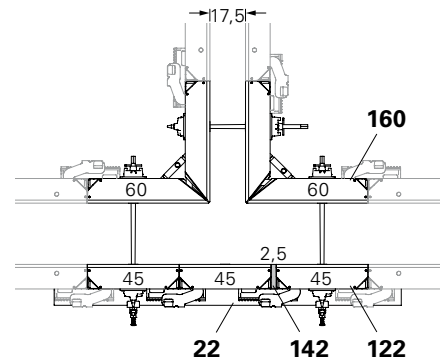


Fig. C5.02

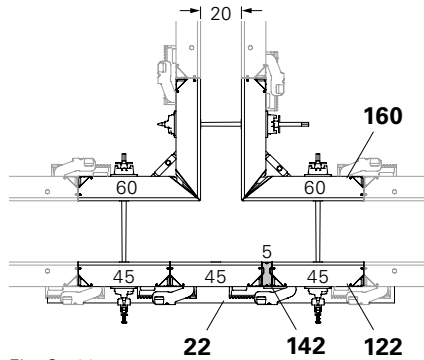


Fig. C5.03

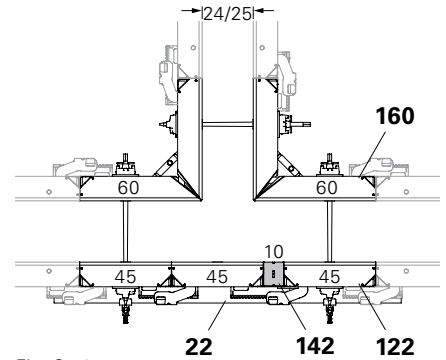


Fig. C5.04

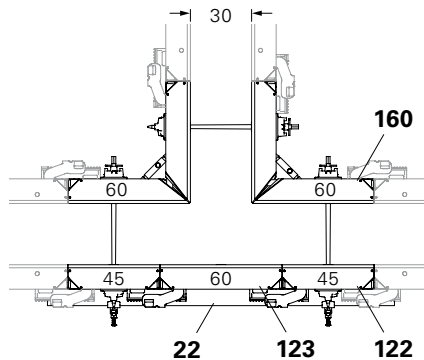


Fig. C5.05

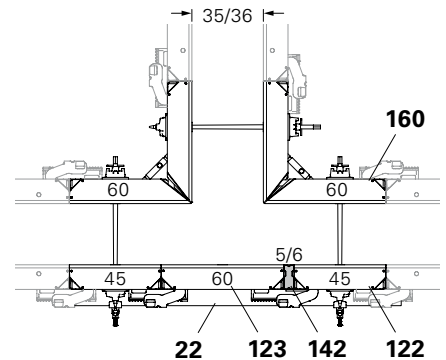


Fig. C5.06

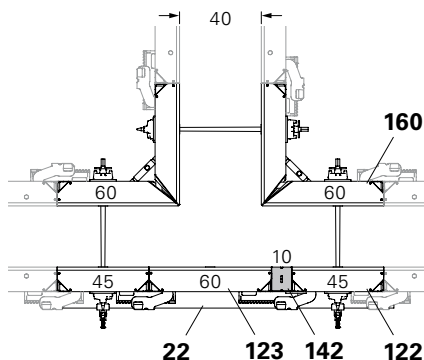


Fig. C5.07



With two Wall Thickness Compensators WDA MX (not shown): install one WDA MX each on the right and left of the middle panel.

Arrangement of the Alignment Couplers and Compensation Walers

Valid for wall thicknesses 15 – 40 cm
(Fig. C5.08 + C5.09)

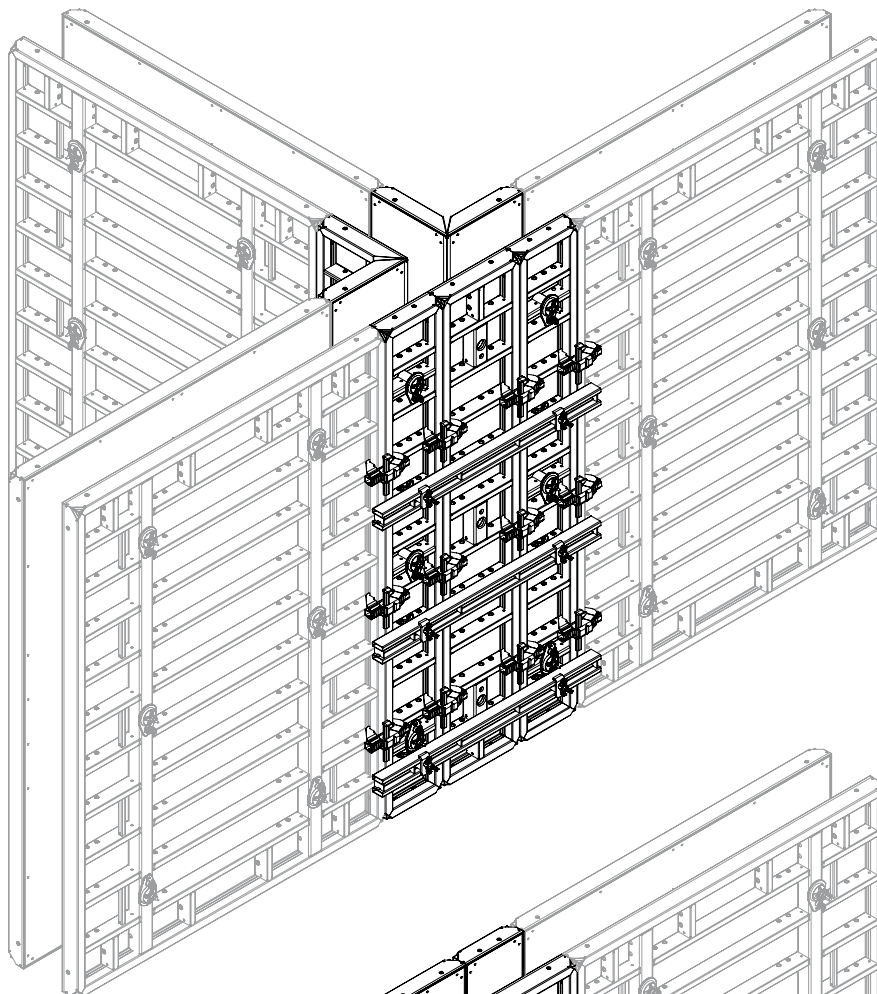


Fig. C5.08

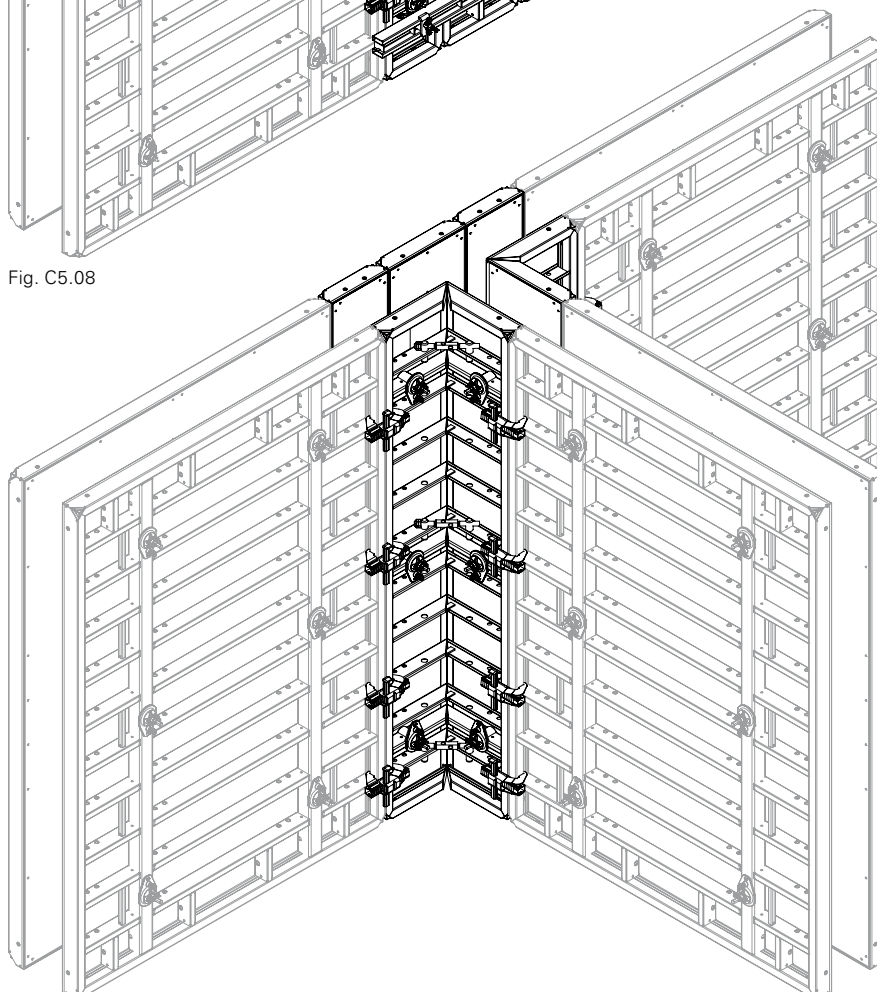


Fig. C5.09

C6 Panel connections following 90° T-junctions

Panel connections

For panels with widths $b \leq 120$ following 90° T-junctions, these must be strengthened at the next panel joint by means of a Compensation Waler MAR 85 (21). (Fig. C6.01)

With extensions, a second Compensation Waler MAR 85 (21) is required on the panel joint (shown as a dotted line). (Fig. C6.02 + C6.03)

Pos.	Components	Item no.
20	Alignment Coupler BFD 023500	
21	Compensation Waler MAR 85-3	124941

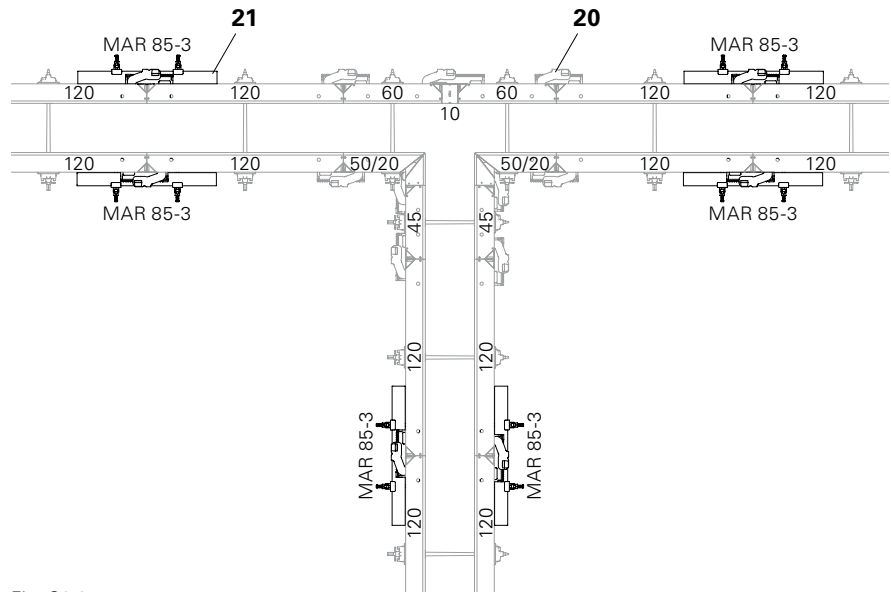


Fig. C6.01

C6 Panel connections following 90° T-junctions

Arrangement of the Alignment Couplers and Compensation Walers

(Fig. C6.02 + C6.03)

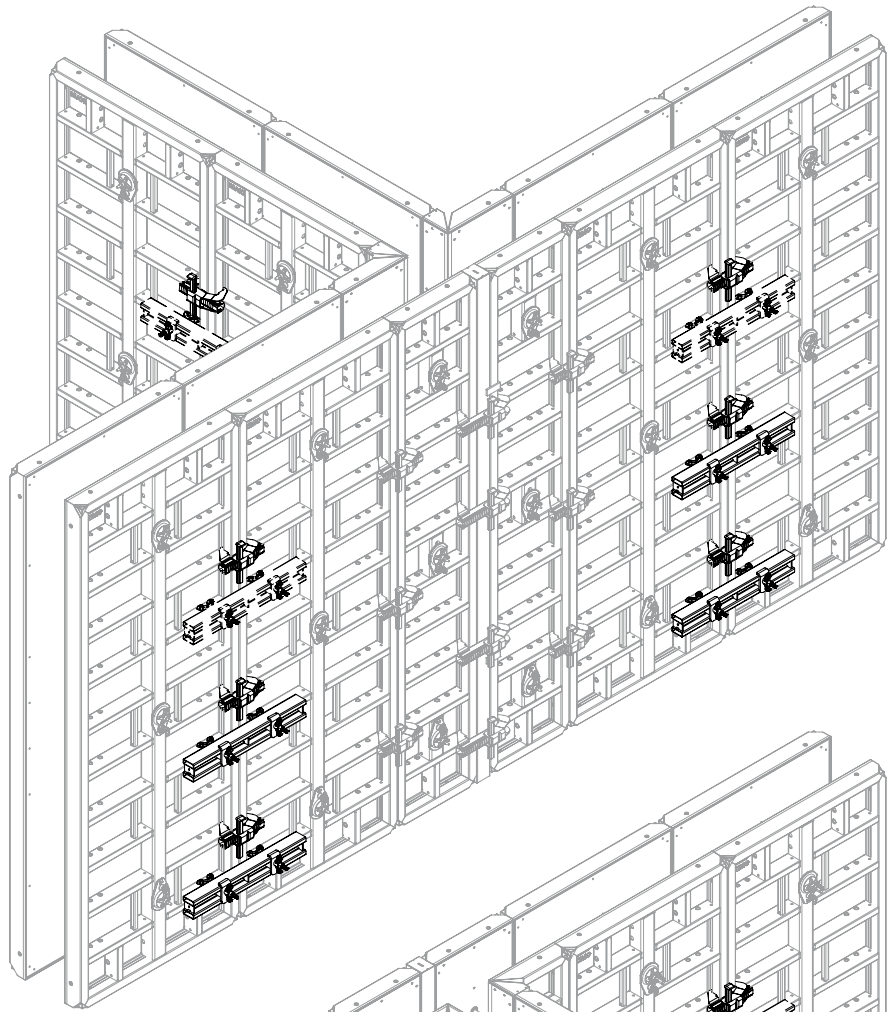


Fig. C6.02

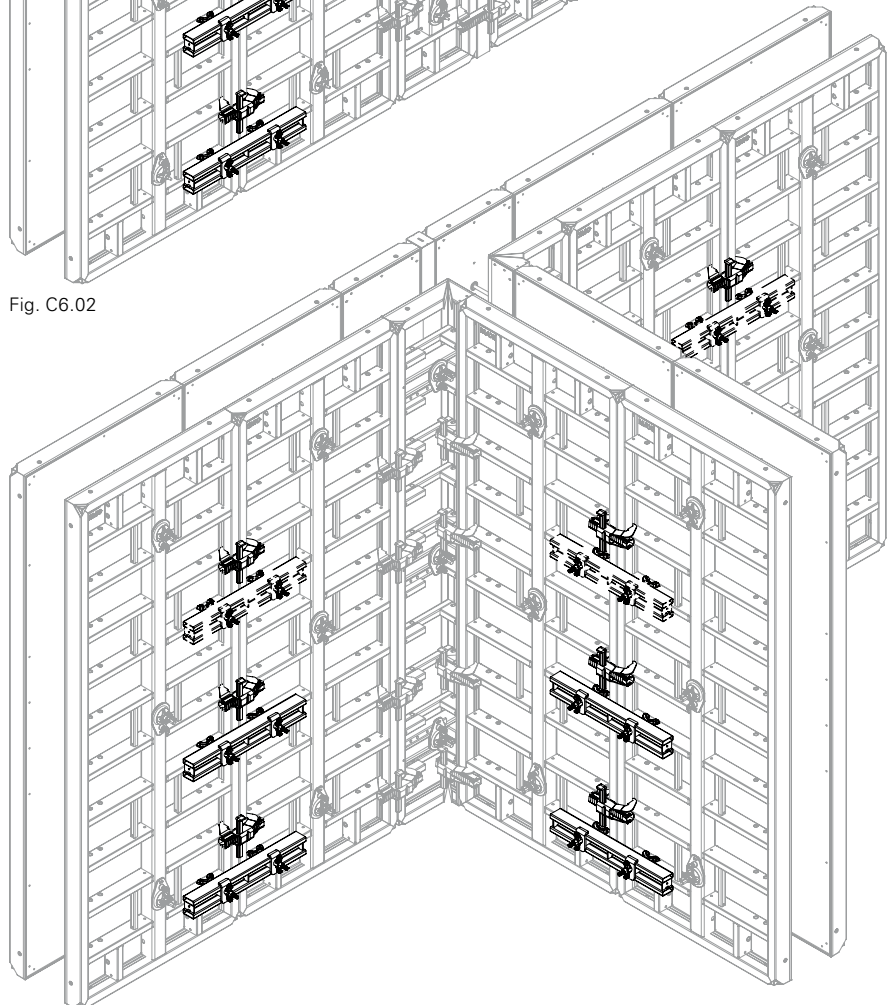


Fig. C6.03

Wall offsets ≤ 20 cm



Perm. fresh concrete pressure: 60 kN/m²

Pos. Components

- 18** Filler timber
- 20** Alignment Coupler BFD
- 22** Compensation Waler MAR 170-3
- 23** Wingnut Pivot Plate DW 15
- 24** Hook Tie DW 15, L = 400
- 120** Multi Panel
MXM 330 x 60
- 121** Panel MX 330 x 30

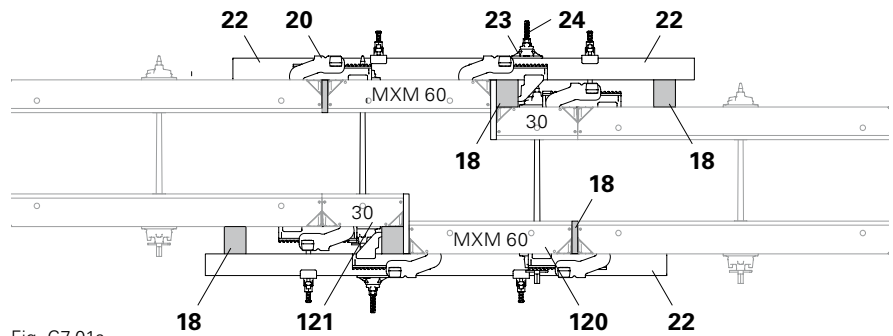


Fig. C7.01a

Shown: wall thickness 30 cm
(Fig. C7.01a + C7.01b)

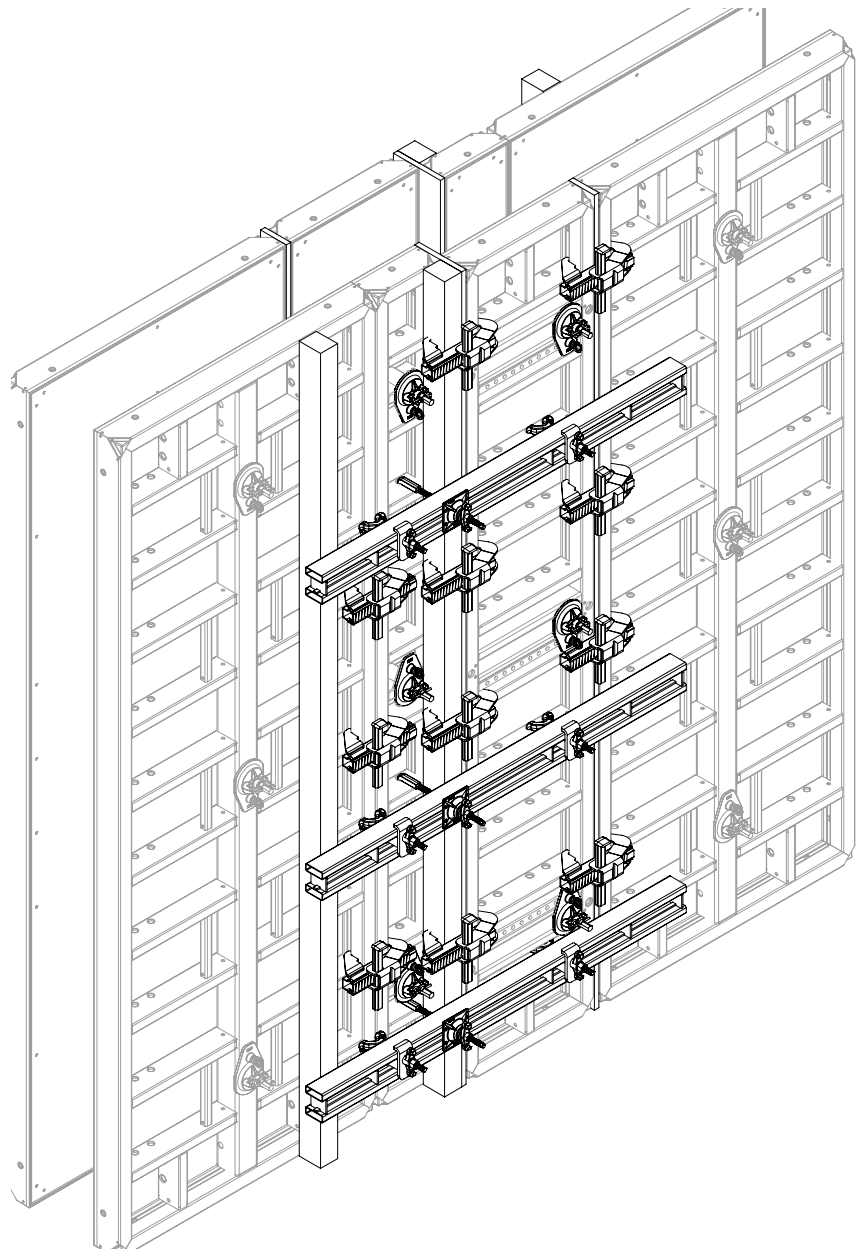


Fig. C7.01b

C7 Wall offsets

Wall offsets 20 – 28 cm



Perm. fresh concrete pressure: 60 kN/m²
With Inside Corner MXI 330 x 50/20

Pos. Components

- 18** Filler timber
- 20** Alignment Coupler BFD
- 21** Compensation Waler MAR 85-3
- 22** Compensation Waler MAR 170-3
- 122** Panel MX 330 x 45
- 161** Inside Corner MXI 330 x 50/20

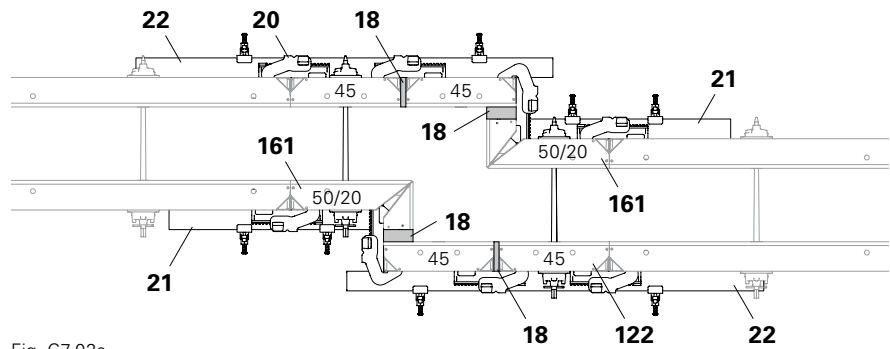


Fig. C7.02a

Shown: wall thickness 30 cm
 (Fig. C7.02a + C7.02b)

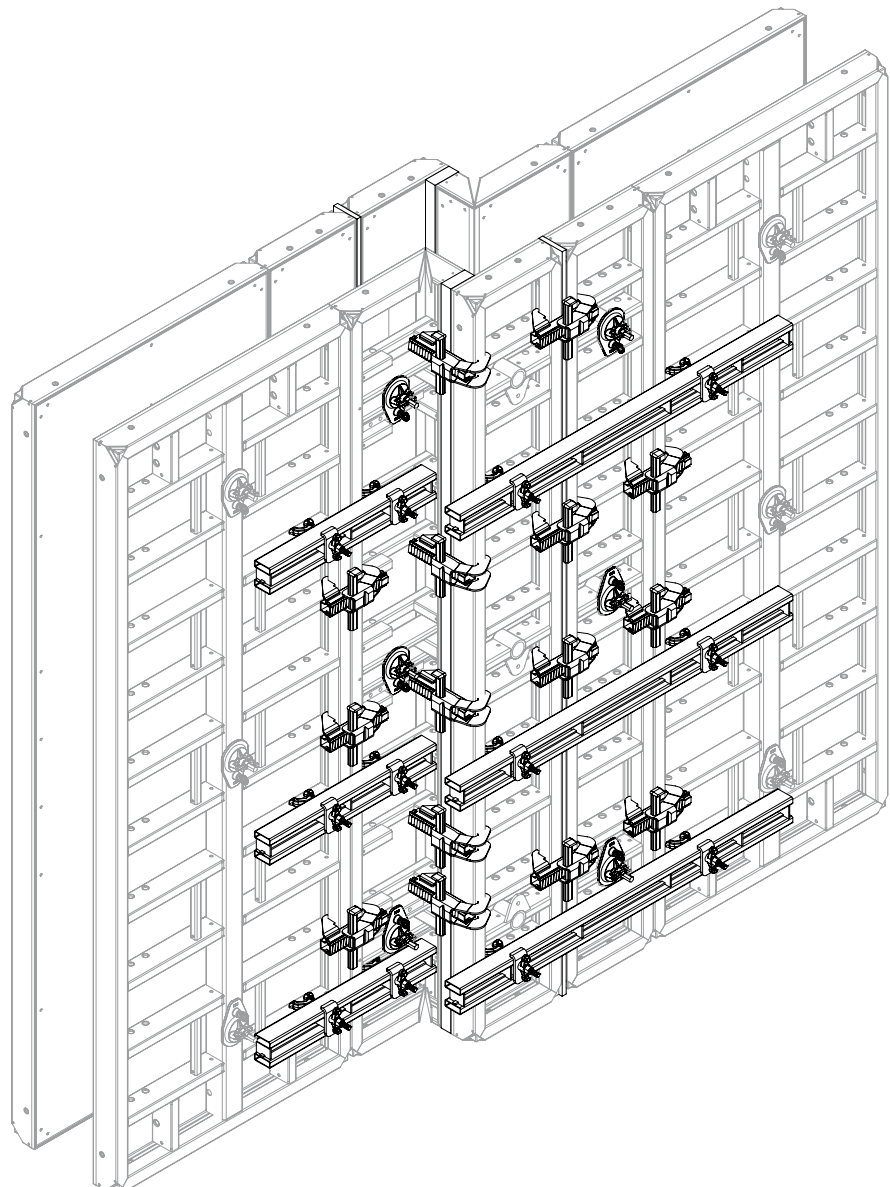


Fig. C7.02b

Wall offsets 28 – 38 cm



Perm. fresh concrete pressure: 60 kN/m²

With Inside Corner MXI 330 x 50/20

Pos. Components

- 18** Filler timber
- 20** Alignment Coupler BFD
- 21** Compensation Waler MAR 85-3
- 22** Compensation Waler MAR 170-3
- 23** Wingnut Pivot Plate DW 15
- 24** Hook Tie DW 15, L = 400
- 120** Multi Panel
MXM 330 x 60
- 121** Panel MX 330 x 30
- 122** Panel MX 330 x 45
- 161** Inside Corner MXI 330 x 50/20
- 240** Stopped Tie MX DW 20

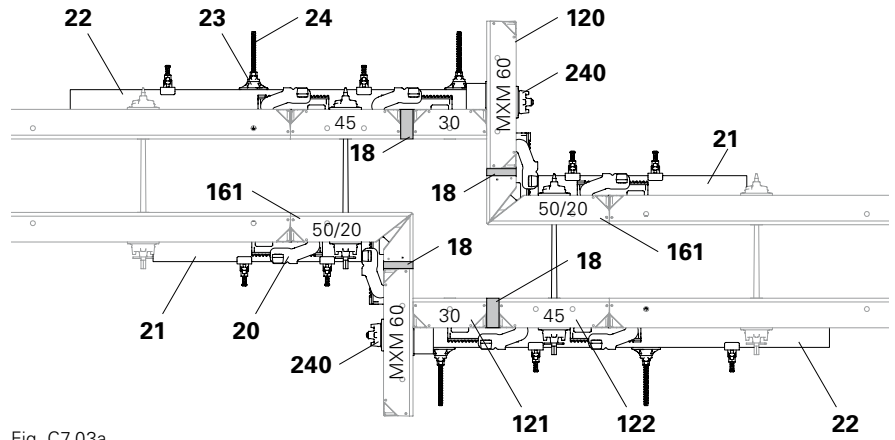


Fig. C7.03a

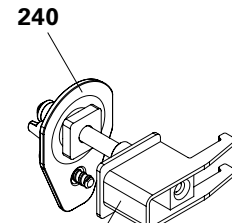


Fig. C7.03d

Shown: wall thickness 30 cm
(Fig. C7.03a to C7.03d)

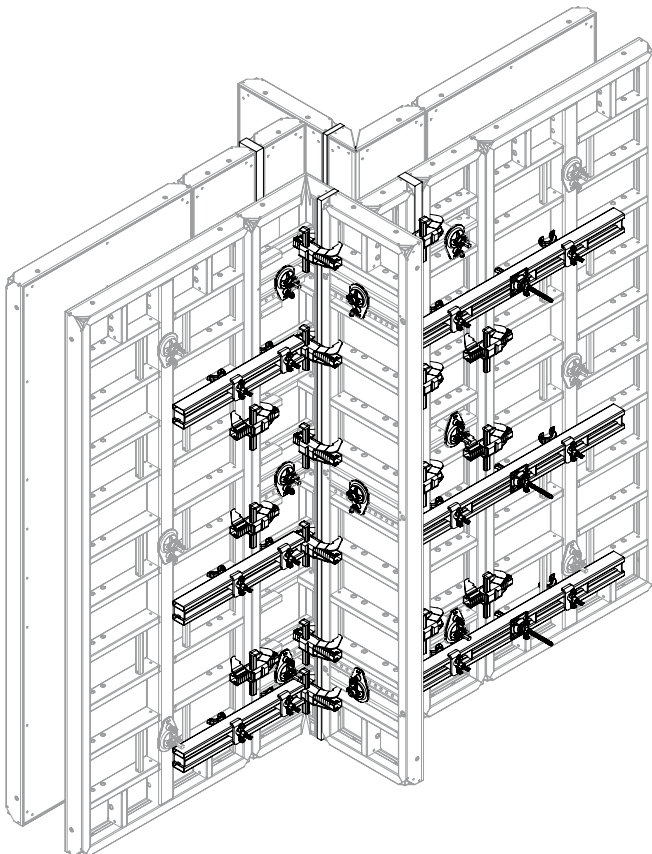


Fig. C7.03b

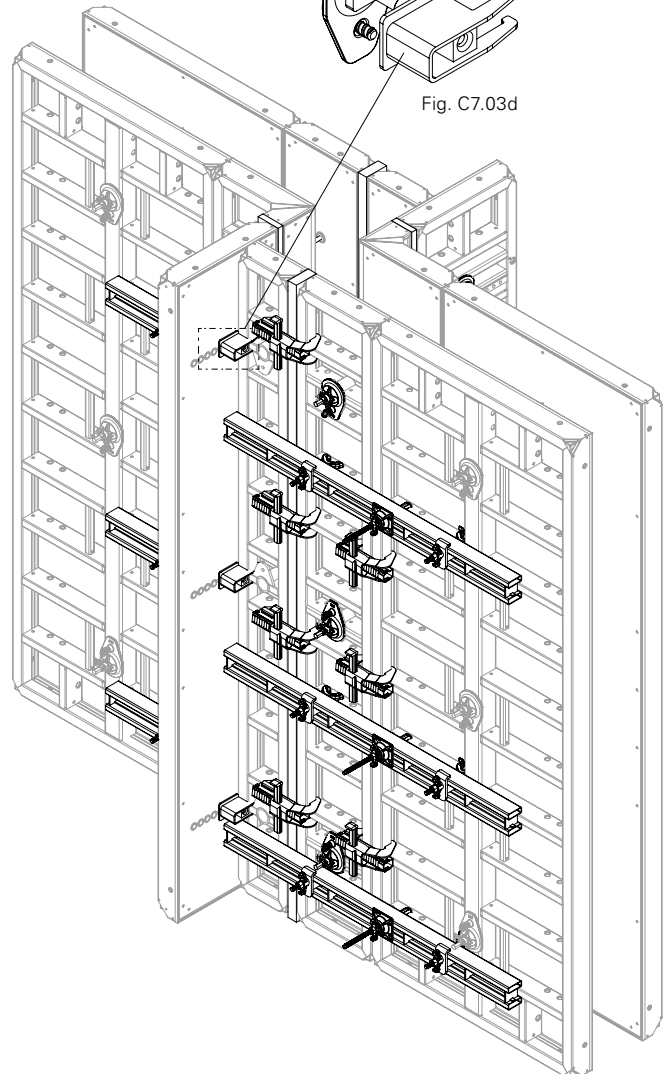


Fig. C7.03c

Wall offsets 38 – 50 cm



Perm. fresh concrete pressure: 60 kN/m²

With Inside Corner MXI 330 x 50/20

Pos. Components

- 18** Filler timber
- 20** Alignment Coupler BFD
- 21** Compensation Waler MAR 85-3
- 22** Compensation Waler MAR 170-3
- 23** Wingnut Pivot Plate DW 15
- 24** Hook Tie DW 15, L = 400
- 121** Panel MX 330 x 30
- 122** Panel MX 330 x 45
- 161** Inside Corner MXI 330 x 50/20

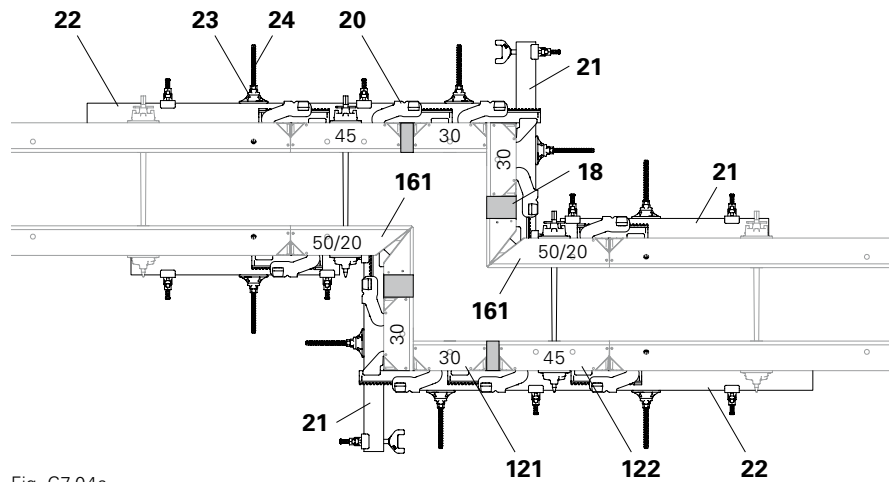


Fig. C7.04a

Shown: wall thickness 30 cm
(Fig. C7.04a + C7.04b)

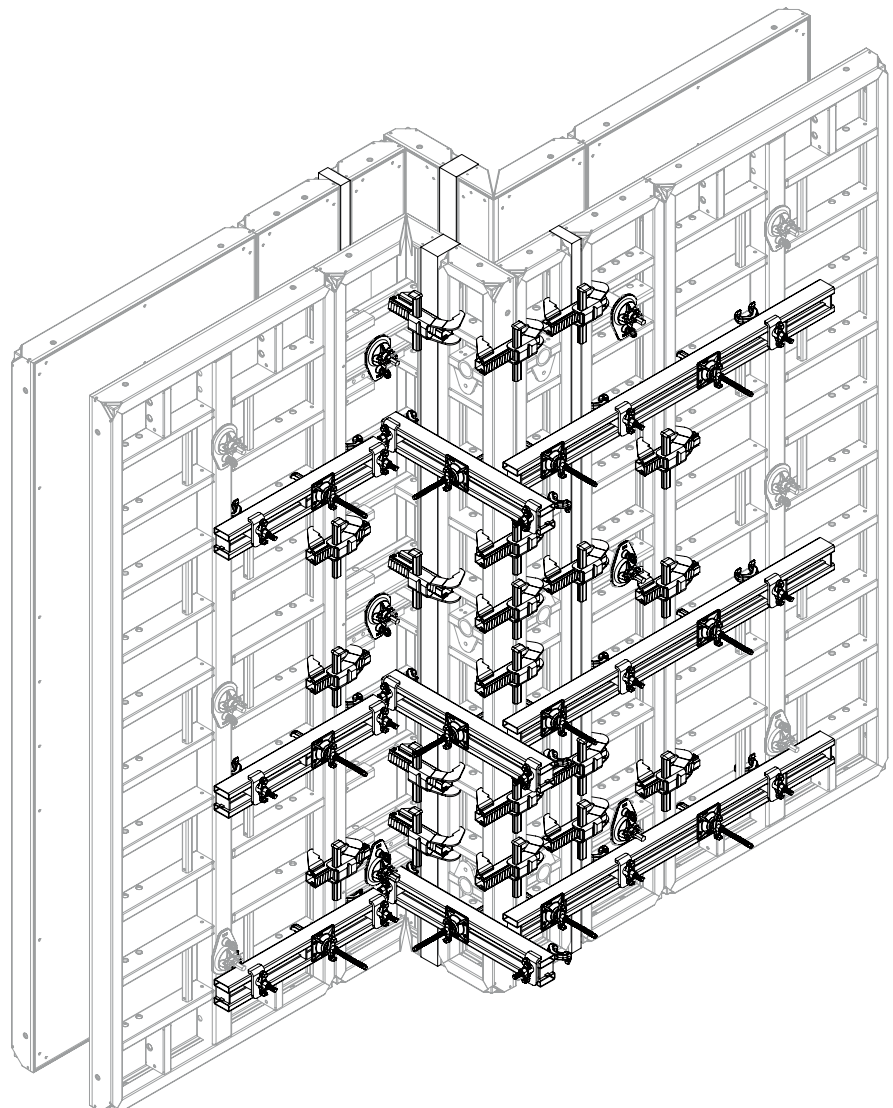


Fig. C7.04b

Wall offsets 50 – 65 cm



Perm. fresh concrete pressure: 60 kN/m²

With Inside Corner MXI 330 x 50/20

Pos. Components

- 18** Filler timber
- 20** Alignment Coupler BFD
- 21** Compensation Waler MAR 85-3
- 22** Compensation Waler MAR 170-3
- 23** Wingnut Pivot Plate DW 15
- 24** Hook Tie DW 15, L = 400
- 121** Panel MX 330 x 30
- 122** Panel MX 330 x 45
- 161** Inside Corner MXI 330 x 50/20

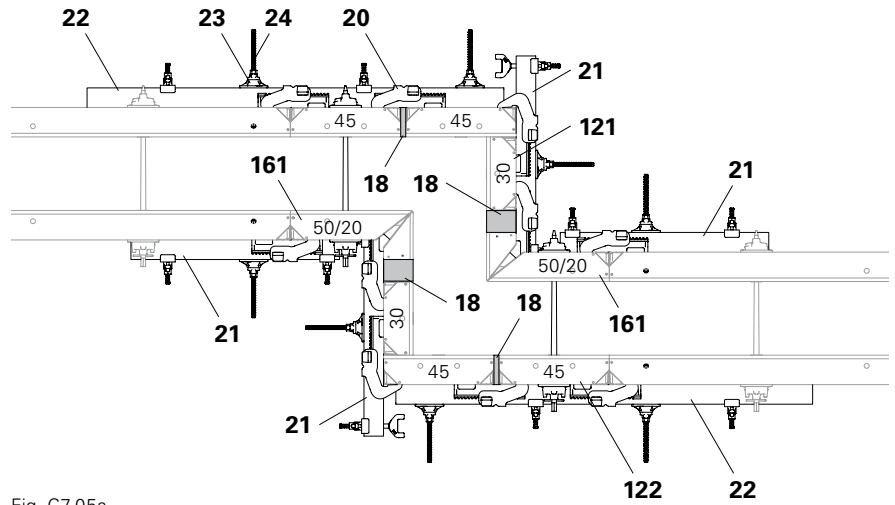


Fig. C7.05a

Shown: wall thickness 30 cm
(Fig. C7.05a + C7.05b)

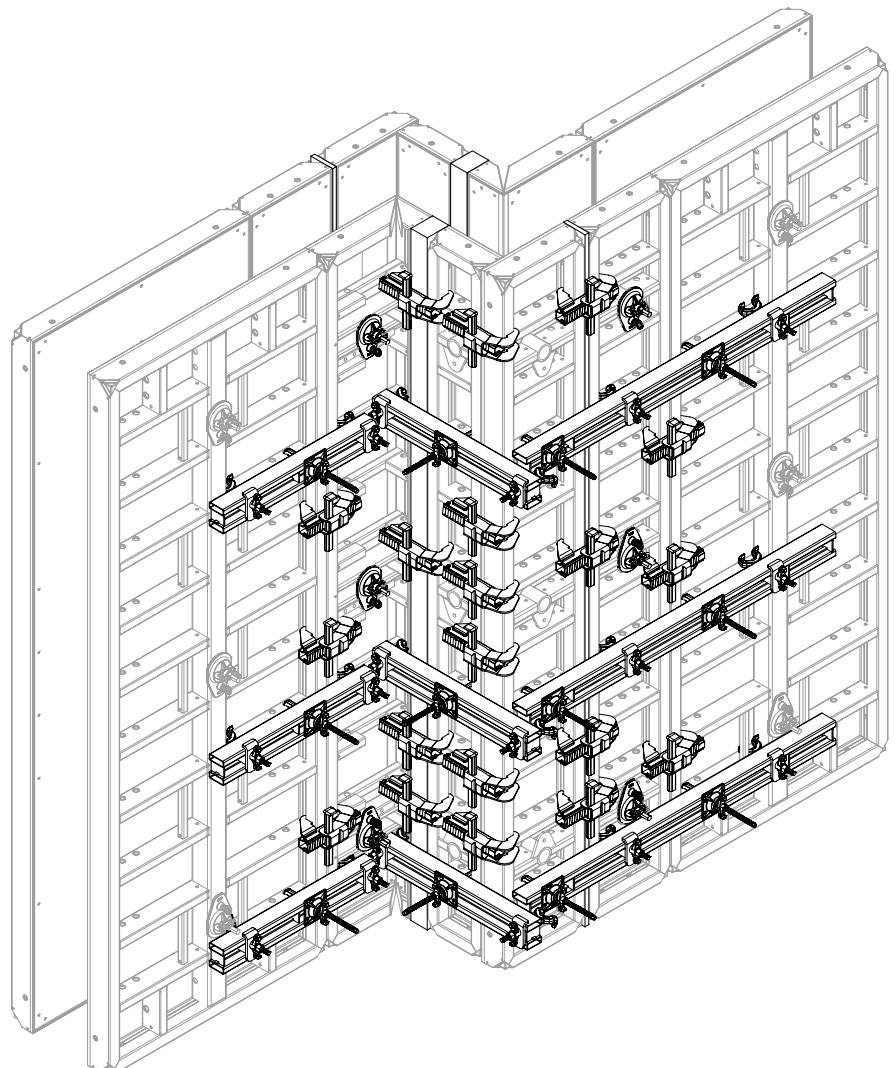


Fig. C7.05b

Wall offsets 65 – 79 cm



Perm. fresh concrete pressure: 60 kN/m²

With Inside Corner MXI 330 x 50/20
and Outside Corner MXA 330 x 45

Pos. Components

- 18** Filler timber
- 20** Alignment Coupler BFD
- 21** Compensation Waler MAR 85-3
- 22** Compensation Waler MAR 170-3
- 23** Wingnut Pivot Plate DW 15
- 24** Hook Tie DW 15, L = 400
- 121** Panel MX 330 x 30
- 159** Outside Corner MXA 330 x 45
- 161** Inside Corner MXI 330 x 50/20

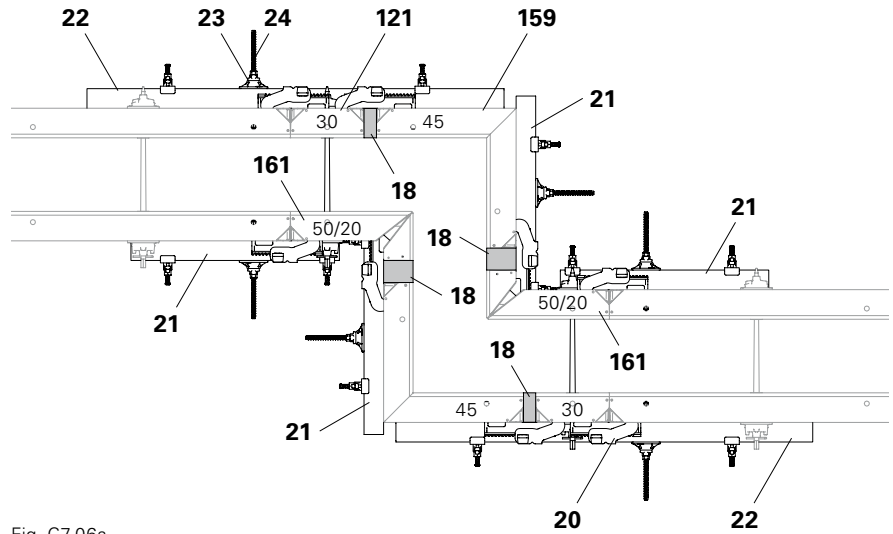


Fig. C7.06a

Shown: wall thickness 30 cm
(Fig. C7.06a + C7.06b)

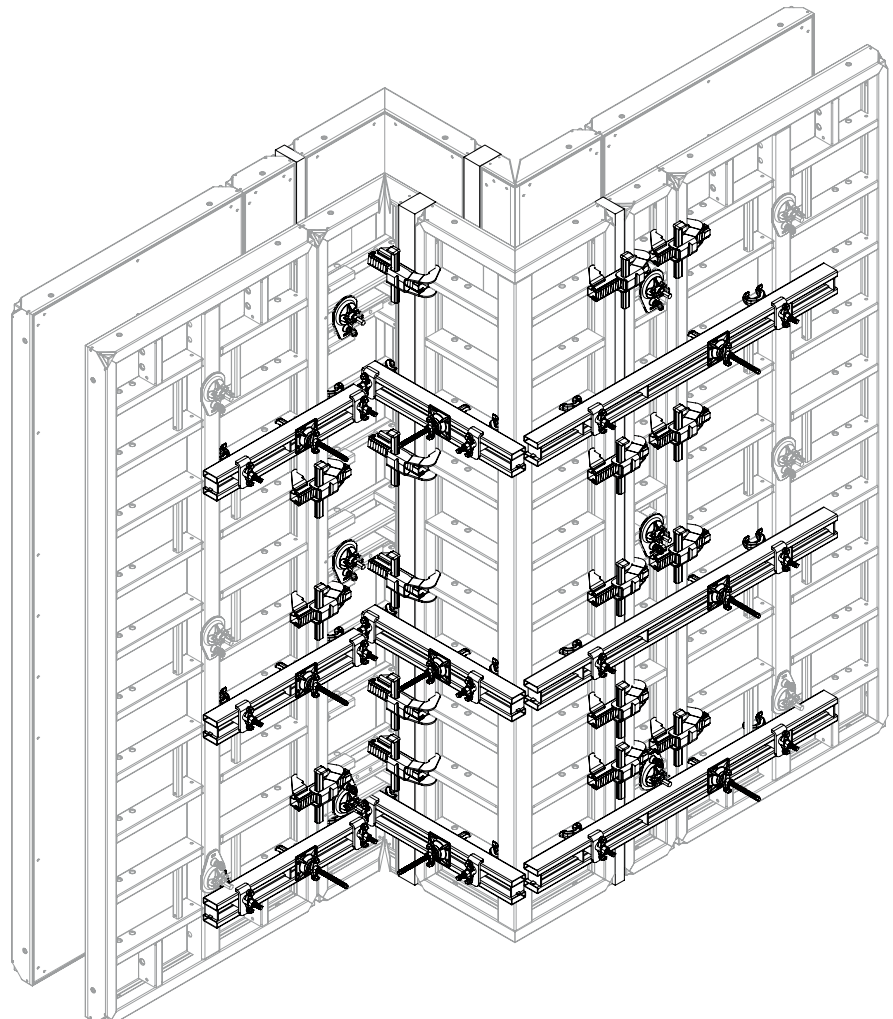


Fig. C7.06b

Wall offsets 65 – 95 cm



Perm. fresh concrete pressure: 60 kN/m²

With Inside Corner MXI 330 x 50/20

Pos. Components

- 18** Filler timber
- 20** Alignment Coupler BFD
- 21** Compensation Waler MAR 85-3
- 22** Compensation Waler MAR 170-3
- 23** Wingnut Pivot Plate DW 15
- 24** Hook Tie DW 15, L = 400
- 122** Panel MX 330 x 45
- 161** Inside Corner MXI 330 x 50/20

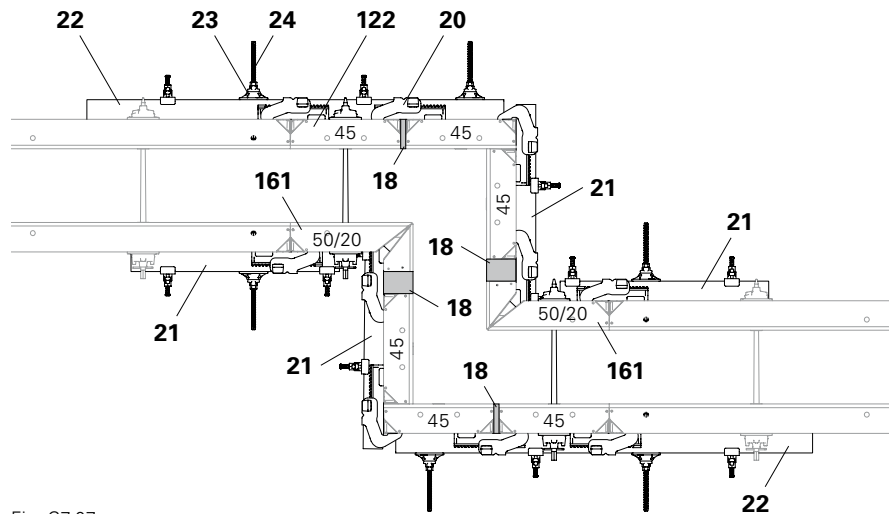


Fig. C7.07a

Shown: wall thickness 30 cm
(Fig. C7.07a + C7.07b)

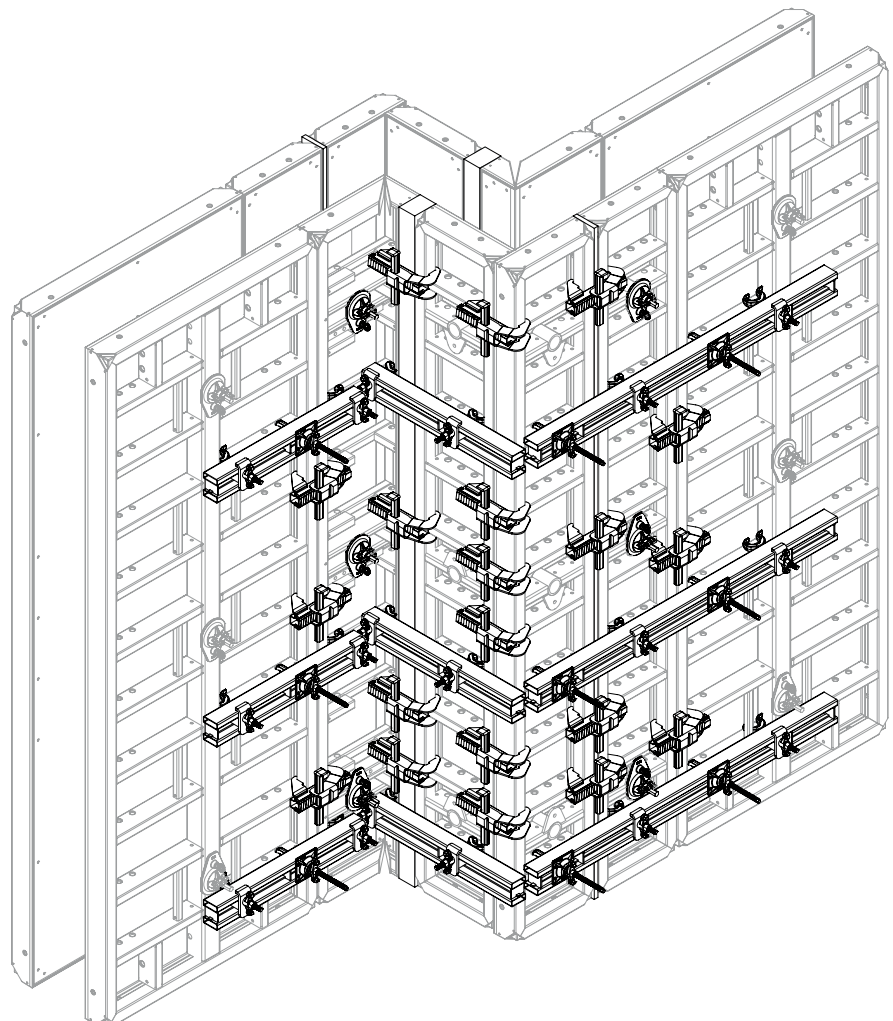


Fig. C7.07b

Wall offsets 95 – 124 cm



Perm. fresh concrete pressure: 60 kN/m²

With Inside Corner MXI 330 x 50/20
and Outside Corner MXA 330 x 45



- 95 – 109 cm: Panel MX 330 x 30
- 110 – 124 cm: Panel MX 330 x 45

Pos. Components

- 18** Filler timber
- 20** Alignment Coupler BFD
- 21** Compensation Waler MAR 85-3
- 22** Compensation Waler MAR 170-3
- 23** Wingnut Pivot Plate DW 15
- 24** Hook Tie DW 15, L = 400
- 121** Panel MX 330 x 30
- 122** Panel MX 330 x 45
- 159** Outside Corner MXA 330 x 45
- 161** Inside Corner MXI 330 x 50/20

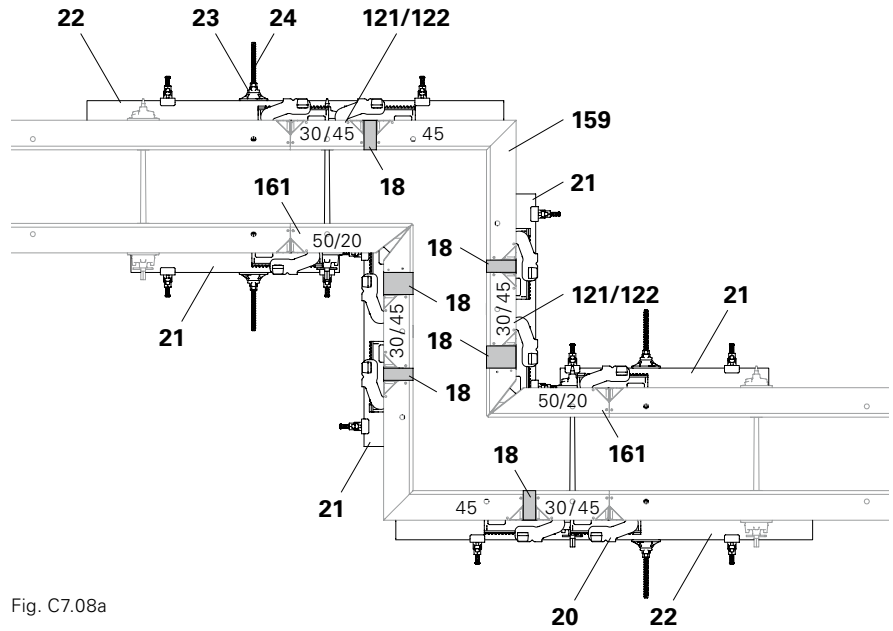


Fig. C7.08a

Shown: wall thickness 30 cm
(Fig. C7.08a + C7.08b)

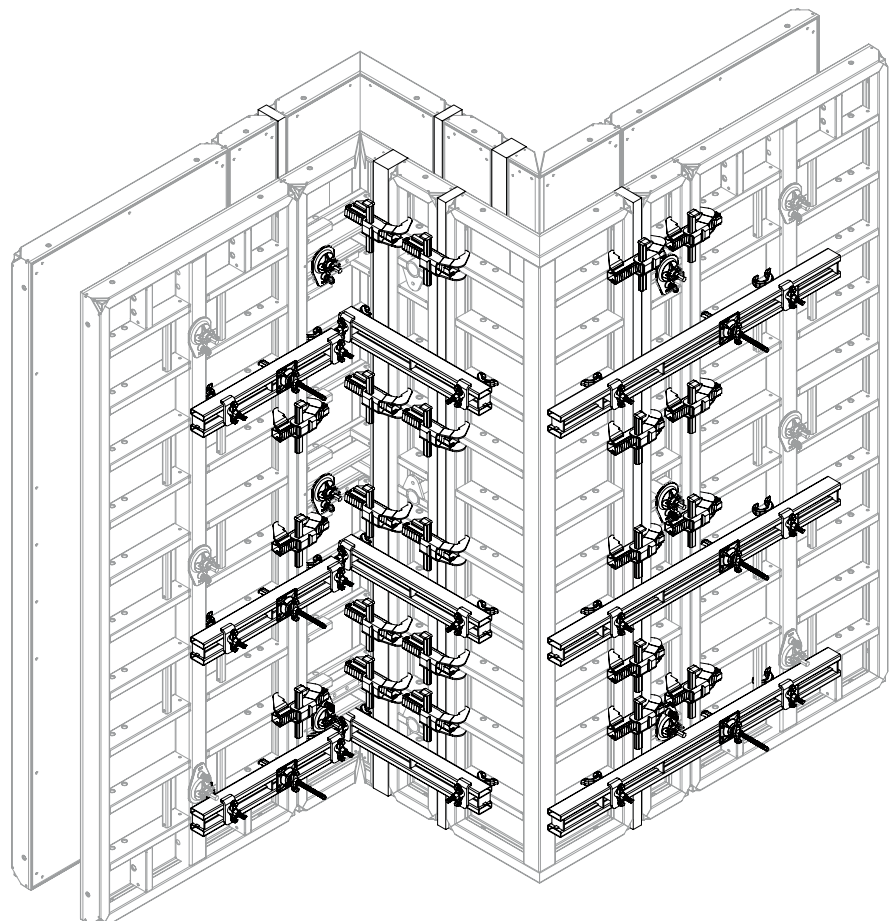


Fig. C7.08b

C8 75° to 165° corners with Articulated Corners MXGI 330 and MXGA 330



- Wall thickness 30 cm – all corners shown.
- The illustrations in Fig. C7.06 + C7.07 apply to 65° to 150° corners and can also be used for 75° and 165° corners. The panel strut actually used is specified in the respective "Arrangement of panel connections" tables.

75° corners

Pos.	Components	Item no.
14	Steel Waler SRU 122	103874
15	Tie Yoke SKZ	024210
20	Alignment Coupler BFD	023500
21	Compensation Waler MAR 85-3	124941
25	Tie Rod DW 15	030030
44	Wingnut DW 15	030100
121	Panel MX 330 x 30	114457
122	Panel MX 330 x 45	114452
142	Wall Thickness Compensation WDA MX 330 x width or filler timber ≤ 10 cm	acc. to width
185	Articulated Corner MXGI 330	114583
186	Articulated Corner MXGA 330	114607

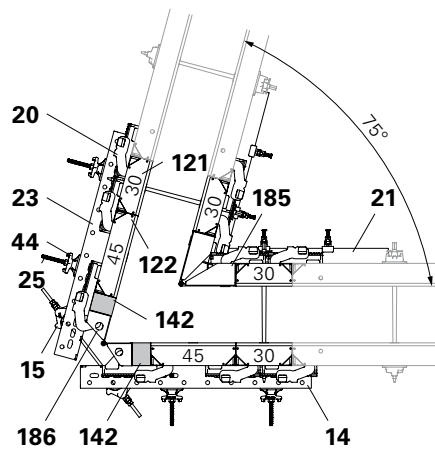


Fig. C8.01

Arrangement of panel connections

75° angles (Fig. C8.01)	Panel strut on Articulated Corner	
	Outside	Inside
BFD (20)	2 5 7 9	2 5 7
MAR 85 (21)	-	1 4 8
SRU 122 (14)**	1 4 8	-

* BFD – offset arrangement

** with Tie Yoke SKZ (15), Tie Rod (25) and Wingnut (44)

C8 75° to 165° corners with Articulated Corners MXGI 330 and MXGA 330

105° to 150° corners

Pos.	Components	Item no.
20	Alignment Coupler BFD 023500	
21	Compensation Waler MAR 85-3	124941
120	Multi Panel MXM 330 x 60	114464
121	Panel MX 330 x 30 for 105° and 135° angles	114457
122	Panel MX 330 x 45 for 120° and 150° angles	114452
142	Wall Thickness Compensation WDA MX 330 x width or filler timber ≤ 10 cm acc. to width	
185	Articulated Corner MXGI 330	114583
186	Articulated Corner MXGA 330	114607

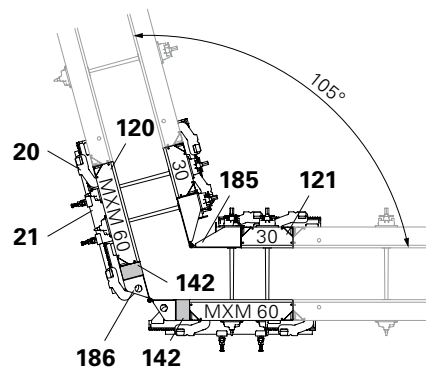


Fig. C8.02

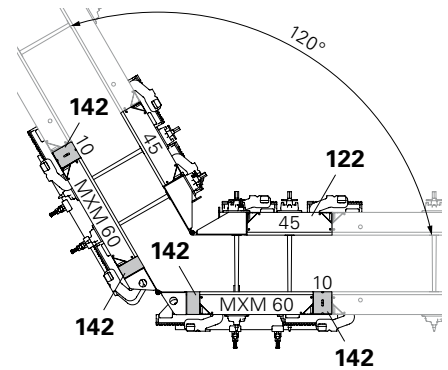


Fig. C8.03

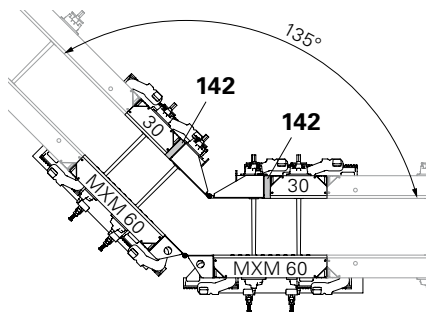


Fig. C8.04

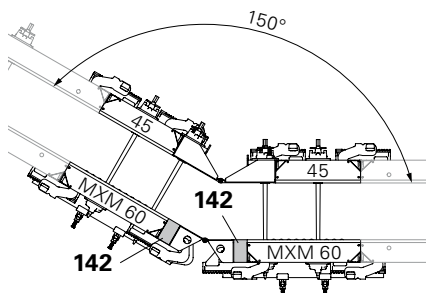


Fig. C8.05

Arrangement of panel connections

105° to 150° angles *	Panel strut on Articulated Corner	
	Outside	Inside
BFD (20)	2 5 7 9	2 5 7
MAR 85 (21)	1 4 8	-

* Angle
 105° – Fig. C8.02 + C8.06 + C8.07
 120° – Fig. C8.03 + C8.06 + C8.07
 135° – Fig. C8.04 + C8.06 + C8.07
 150° – Fig. C8.05 + C8.06 + C8.07



- External panel strut (9) :
No Alignment Coupler BFD required on following panel.
- 105° + 135° angles:
Offset arrangement of Alignment Couplers (20) on Articulated Corner MXGI (185). (Fig. C8.02 + Fig. C8.04)

Outside

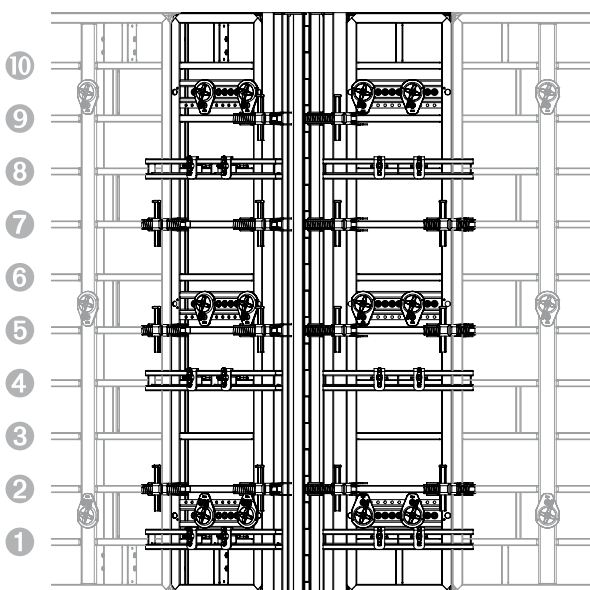


Fig. C8.06

Inside

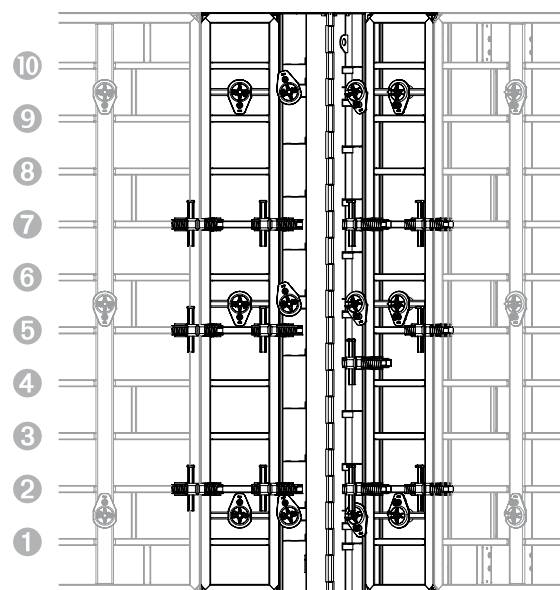


Fig. C8.07

C8 75° to 165° corners with Articulated Corners MXGI 330 and MXGA 330

165° corners

Pos.	Components	Item no.
20	Alignment Coupler BFD 023500	
21	Compensation Waler MAR 85-3	124941
120	Multi Panel MXM 330 x 60	114464
122	Panel MX 330 x 45	114452
142	Wall Thickness Compensation WDA MX 330 x width or filler timber ≤ 10 cm according to width	
185	Articulated Corner MXGI 330	114583
186	Articulated Corner MXGA 330	114607

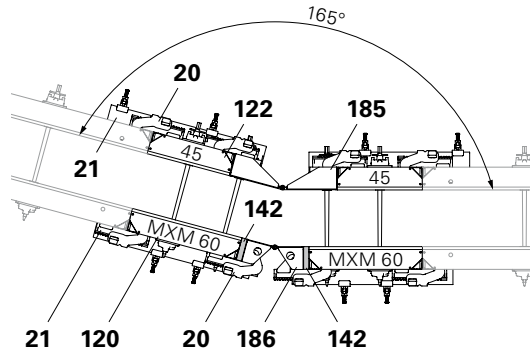


Fig. C8.08



External panel strut ⁹ :
No Alignment Coupler BFD required on
following panel.

Arrangement of panel connections

Angle 165° (Fig. C8.08)	Panel strut on Articulated Corner	
	Outside	Inside
BFD (20)	2 5 7 9	2 5 7
MAR 85 (21)	1 4 8	1 4 8

C9 Length compensations

WDA MX 330

Length compensation up to 10 cm

Pos.	Components	Qty.
20	Alignment Coupler BFD	4x
142	Wall Thickness Compensation WDA MX 330 x width or filler timber	1x



No additional ties required!

Length compensation takes place with Wall Thickness Compensation WDA MX (142) or using timber which has been cut to size.

Note: number and arrangement of the BFD Alignment Couplers (20).

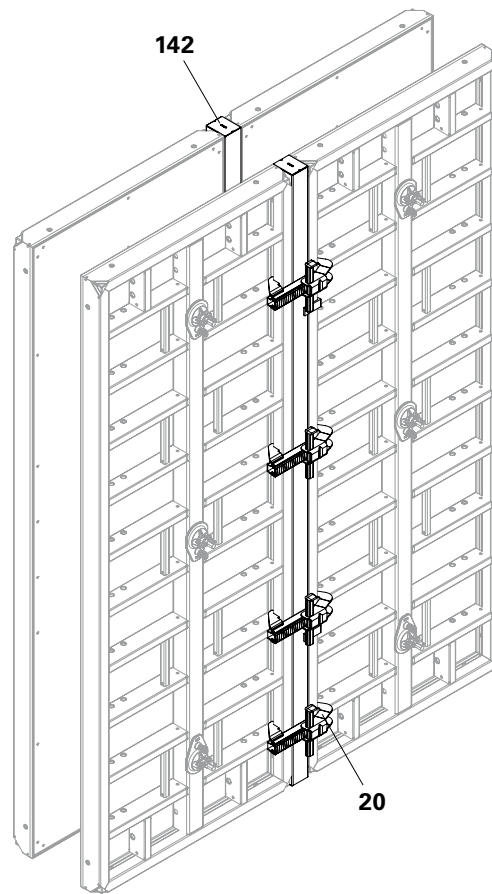


Fig. C9.01

Filler Profile TPP

Length compensation from 20 to 36 cm



- Perm. fresh concrete pressure
80 kN/m² for: $b \geq 20$ and $b < 30$ cm
- Perm. fresh concrete pressure
60 kN/m² for: $b \geq 30$ and $b \leq 36$ cm

Pos.	Components	Qty.
20	Alignment Coupler BFD	6x
21	Compensation Waler MAR 85-3	3x
51	Plywood filler 21 mm	1x
53	Filler Profile TPP 330 or filler timber	4x (2x)

When anchoring, ensure that the tie forces are transferred centrally through the Compensation Waler MAR 85 (21) to the adjacent panels.
(Fig. C9.02b)

Installation (Fig. C9.02 + C9.02a)



Here, the filler profile is only available in lengths of 270 and 120 cm. As an alternative to the Filler Profile TPP, timber (2x) can be used. (Not shown)

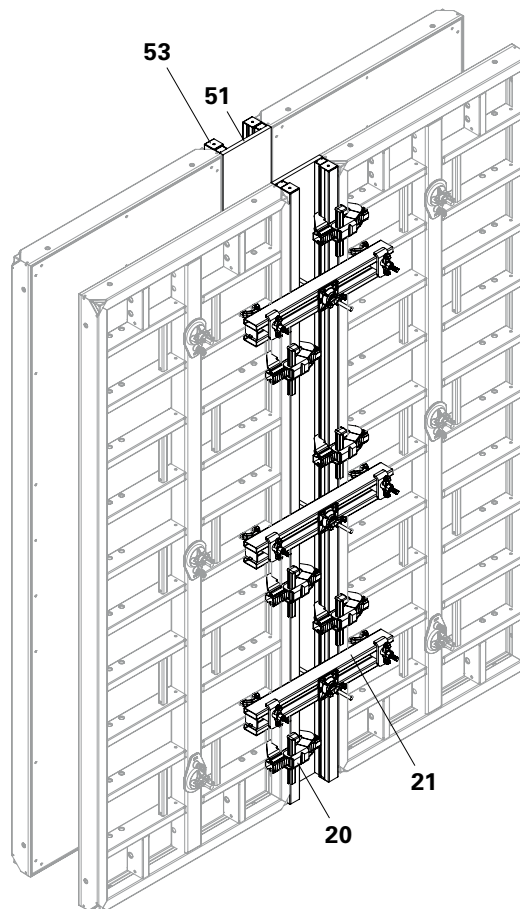


Fig. C9.02

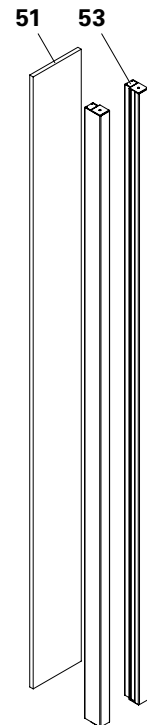


Fig. C9.02a

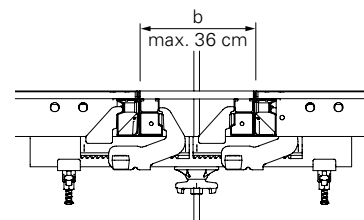


Fig. C9.02b

Stopend Waler



The fresh concrete pressure of the stopend formwork is transferred to the MAXIMO Panels by means of the Stopend Walers.

Wall end with Panels

MX 330 x width

Valid for MAXIMO Panels MX:

330 x 30/45/60/90/120/240

Shown: 330 x 120

Wall thickness ≤ 30 cm

Perm. fresh concrete pressure 80 kN/m²

(Fig. C10.01 + C10.01a)

Pos.	Components	Item no.
18	Filler timber	
50	Stopend Waler MX 15-40	127732
51	Plywood filler 21 mm	

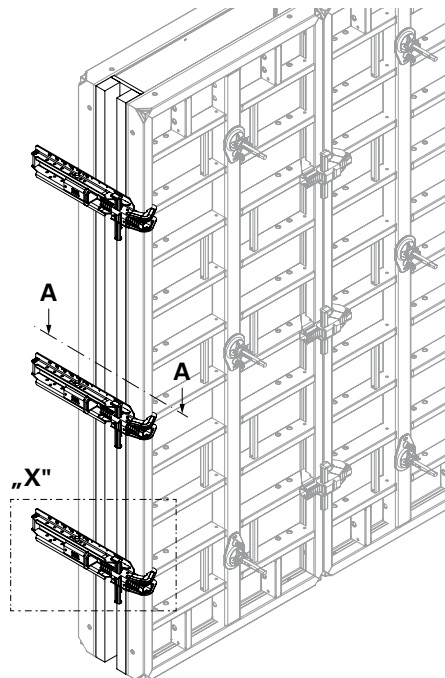


Fig. C10.01

Detail "X"

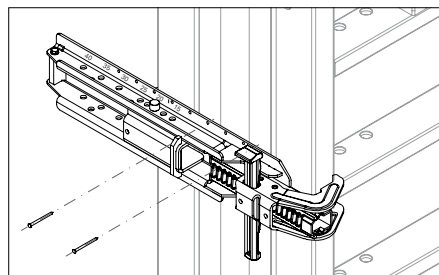


Fig. C10.01a



Fix 3x Stopend Walers with 2 nails each thus ensuring that the filler timber does not slide inwards. (Fig. C10.01a)

Section A-A

WD 15 to WD 30

(Fig. C10.01b)

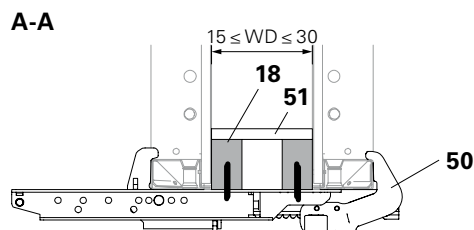


Fig. C10.01b

C10 Stopend formwork

Wall thickness > 30 cm

- Perm. fresh concrete pressure
80 kN/m² (Fig. C10.02 + C10.02a)
- Perm. fresh concrete pressure
60 kN/m² (Fig. C10.03 + C10.02a)

Pos.	Components	Item no.
18	Filler timber	
50	Stopend Waler MX 15-40	127732
51	Plywood filler 21 mm	



Fix 3x Stopend Walers with 2 nails each thus ensuring that the filler timber does not slide inwards. (Fig. C10.01a)

Section B-B
WD > 30 to WD 40
(Fig. C10.02a)

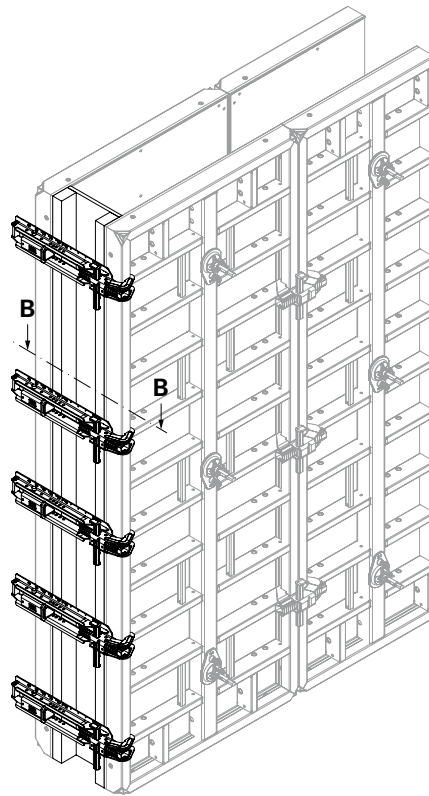


Fig. C10.02

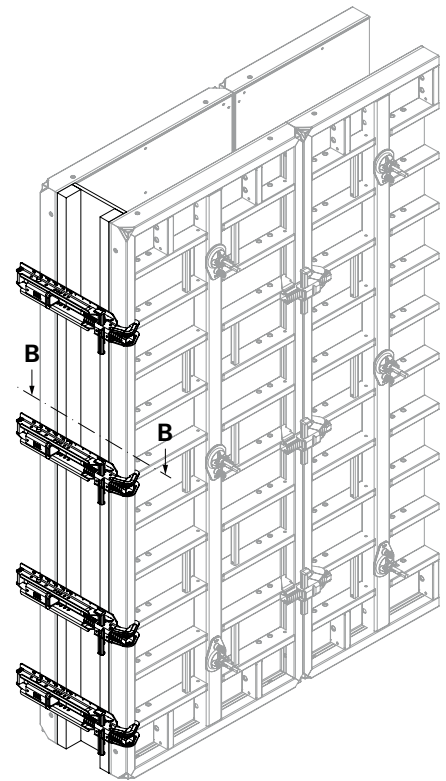


Fig. C10.03

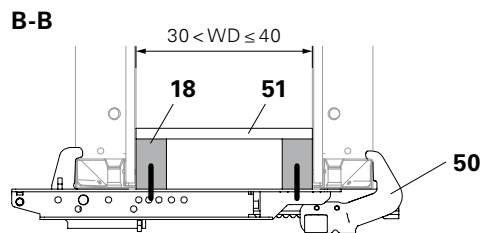


Fig. C10.02a

Stopend Tie and Compensation Waler

For wall thickness ≤ 40 cm



The fresh concrete pressure of the stopend formwork is transferred to the MAXIMO Panels via the Stopend Ties and Walers 85.

Wall end with Panels MX 330 x width

Valid for MAXIMO Panels:
MX 330 x 30/45/60/120/90
Shown: MX 330 x 120
(Fig. C10.07 + C10.08)

Pos.	Components	Qty.
18	Filler timber	2x
23	Wingnut Pivot Plate DW 15	14x
25	Tie Rod DW 15	3x
27	Top Tie Bracket-2 AH	6x
28	Stopend Tie TS	8x
51	Plywood filler 21 mm	1x
241	Waler 85	4x

Waler 85 (241) with Stopend Tie (28) and Wingnut Pivot Plate (23).
(Fig. C10.08b)

– Top Tie Bracket-2 AH with Tie Rod (25) and Wingnut Pivot Plate (23).
(Fig. C10.08a)



As an alternative to Waler 85 (241), the Compensation Waler MAR 85-3 can also be used.

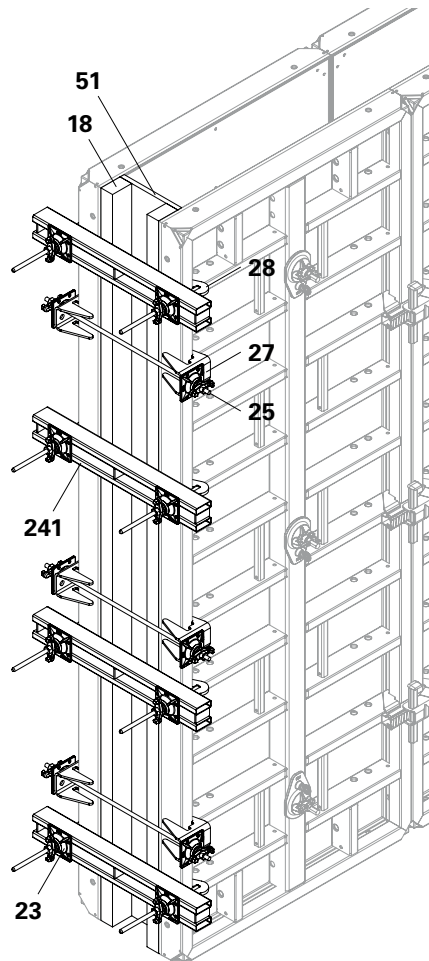


Fig. C10.07

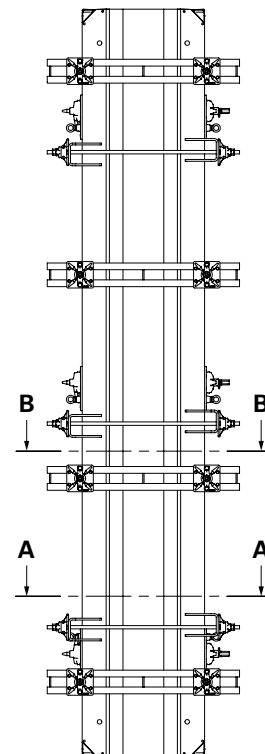


Fig. C10.08

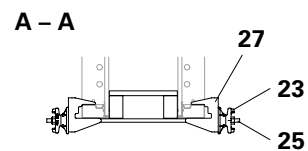


Fig. C10.08a

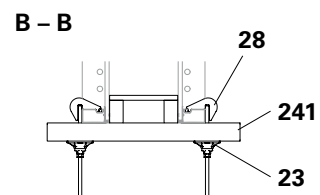


Fig. C10.08b

With Panel MX 330 x 240 at the end of the wall

(not shown)

Pos.	Components	Qty.
18	Filler timber	2x
23	Wingnut Pivot Plate DW 15	8x
28	Stopend Tie TS	8x
51	Plywood filler 21 mm	1x
241	Waler 85	4x

Waler 85 (241) with Stopend Tie (28) and Wingnut Pivot Plate (23).

Alignment Coupler BFD

Use Panel MX 330 x 30 (121) as a Stopend Panel for 30 cm wall thicknesses. (Fig. C10.06)

Pos.	Components
20	Alignment Coupler BFD
121	Panel MX 330 x 30



Alternatively, it is possible to use Panel TRIO 330 x 24 as a Stopend Panel.

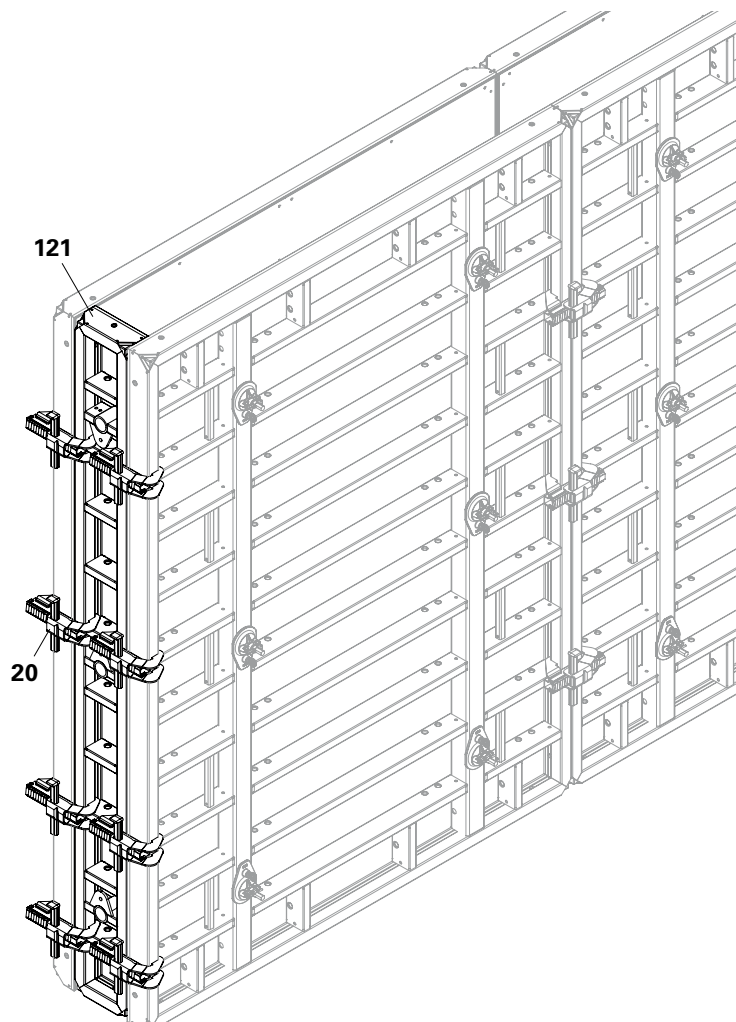


Fig. C10.06

MX 15-40 / MX 15-100

With a concreting height of 3.30 m, the top tie is not required if a Tension and Compression Brace MX 15-40 or MX 15-100 is used.

The panel is braced through the use of two Tension and Compression Braces (70). (Fig. C11.01)

Pos.	Components	Item no.
10	Panel MX height x width	
10.9	Extension strut	
70	Tension and Compression Brace MX 15 – 40	115350
70.1	Safety Hook	
71	Tension and Compression Brace MX 15 – 100	123842



- Setting dimension = wall thickness
- Preparation and assembly of the Tension and Compression Brace, see Section A9.
- Mount the two outside Tension and Compression Braces exactly over the outside extension struts (10.9). (Fig. C11.01a)
- Close open tie holes on the formlining by means of Plug MXM 15, Item no. 124895, see Closures in Section A5.
- Always mount platforms and brackets on the side of the securing hook (70.1) – here the closing formwork. (Not shown)

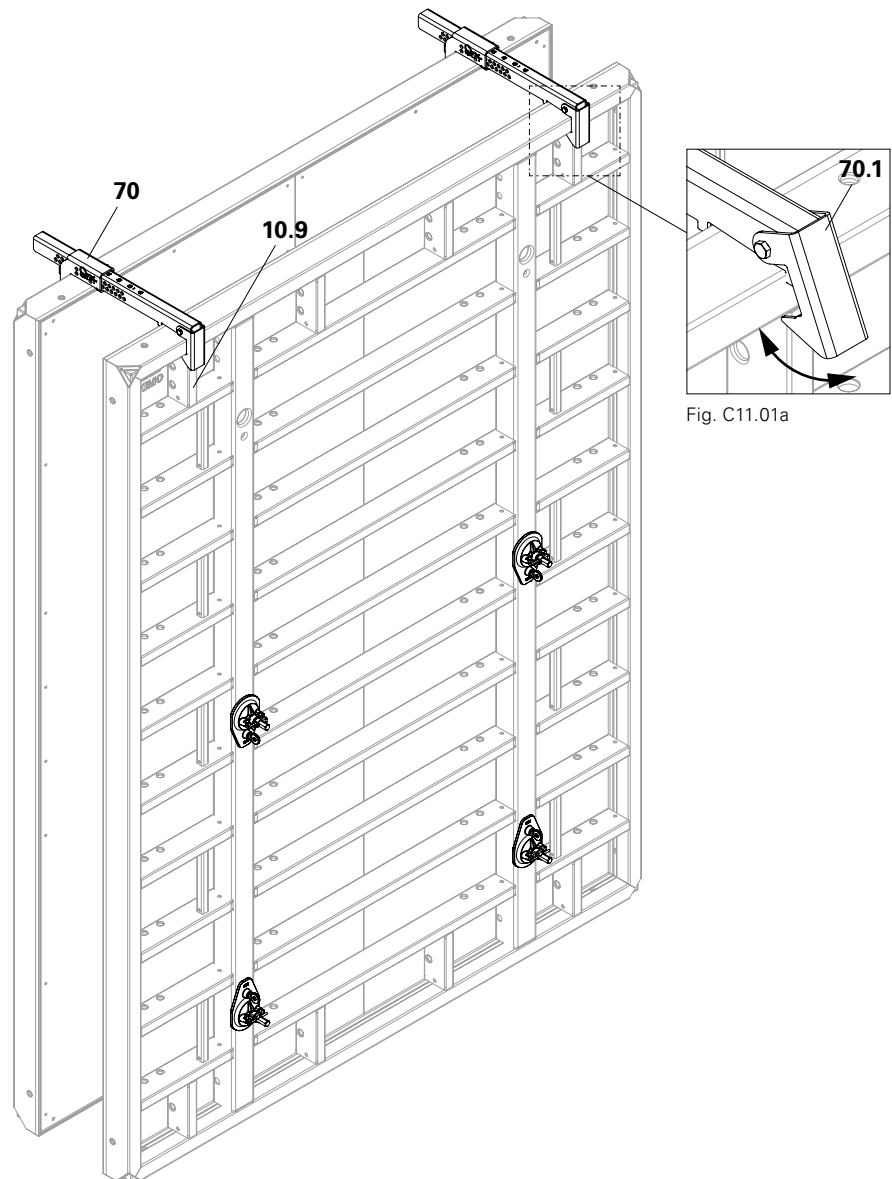


Fig. C11.01

Extension guidelines

Horizontal pre-assembly up to
H = 6.60 m



Warning

Risk of injury!

⇒ Swivel nuts of the tie points must be mounted on the primary formwork!

Pos.	Components	Item no.
20	Alignment Coupler BFD 023500	
21	Compensation Waler MAR 85-3	124941

Panel connections

For height extension units

- For extension units H = 7.20 m, Alignment Couplers BFD (20) and Compensation Walers MAR 85 (21) are to be used on the panel joints. (Fig. C12.01a + C12.01b)
- H ≤ 5.70 m (Fig. C12.01c)
 - on panel joint 330 – 120, install Alignment Coupler BFD (20) and Compensation Waler MAR 85 (21),
 - on panel joint 120 – 90, install Alignment Coupler BFD (20).

Assembly

- The assembly surface must be level.
- Place timbers or planks in position as support.
- Pre-assemble extension units in a horizontal position, with the formlining facing downwards.



For additional extension possibilities, number and arrangement of Alignment Coupler BFD, Compensation Waler MAR 85-3 as well Tie MX 15 – see MAXIMO poster.

MX 330 x
60 / 90 / 120

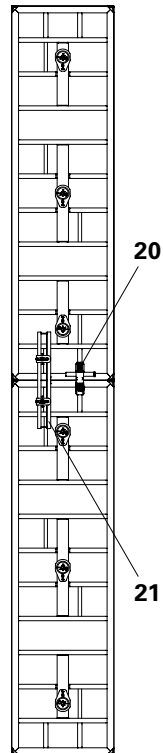


Fig. C12.01a

MX 330 x 240

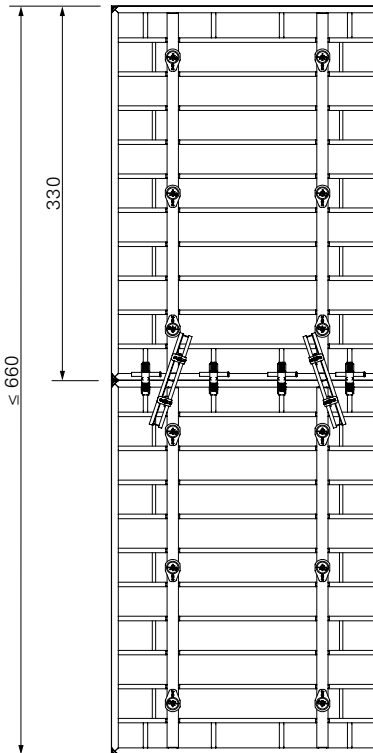


Fig. C12.01b

MX 330 x 240

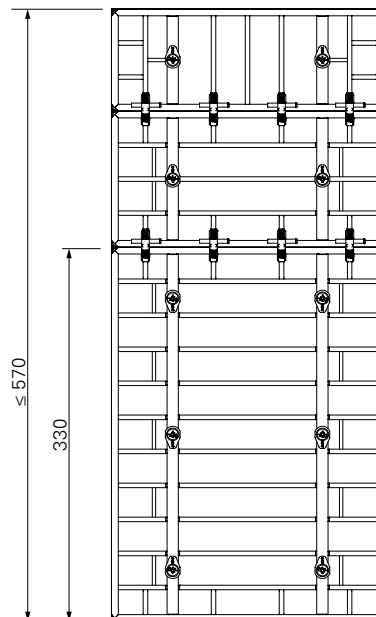


Fig. C12.01c

Erection with the crane

(Fig. C12.02)



Warning

Risk of injury!

- ⇒ Do not exceed the permissible load-bearing capacity of the Lifting Hook MAXIMO and the crane capacity!
- ⇒ Observe the Instructions for Use for the Lifting Hook MAXIMO 1.5 t!



Extension units can be erected with the crane up to a height $H = 8.10$ m with additional bracing.

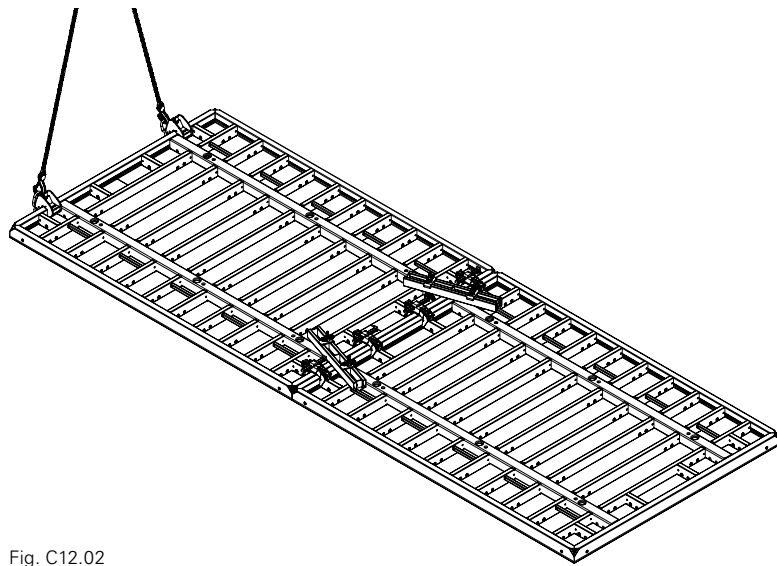


Fig. C12.02

Horizontal pre-assembly up to $H = 7.20$ m



Warning

Risk of injury!

⇒ Swivel nuts of the tie points must be mounted on the primary formwork!

Pos.	Components	Item no.
20	Alignment Coupler BFD	023500
21	Compensation Waler MAR 85-3	124941

Panel connections

For height extension units

- $H = 7.20$ m (Fig. C12.03a)
 - on panel joint 330 – 330, install Alignment Coupler BFD (20) and Compensation Waler MAR 85 (21),
 - on panel joint 330 – 60, install Alignment Coupler BFD (20).
- For extension units $H \leq 6.00$ m, Alignment Couplers BFD (20) and Compensation Walers MAR 85 (21) are to be used on the panel joints. (Fig. C12.03b)

MX 330 x 240

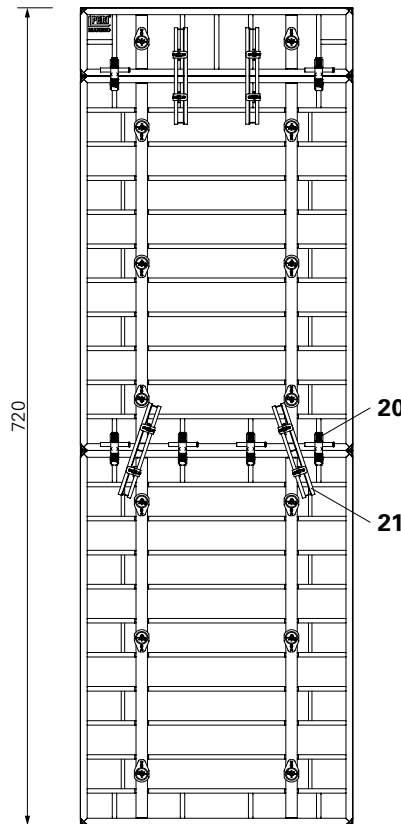


Fig. C12.03a

MX 15, 330 x 240
Horizontal panels

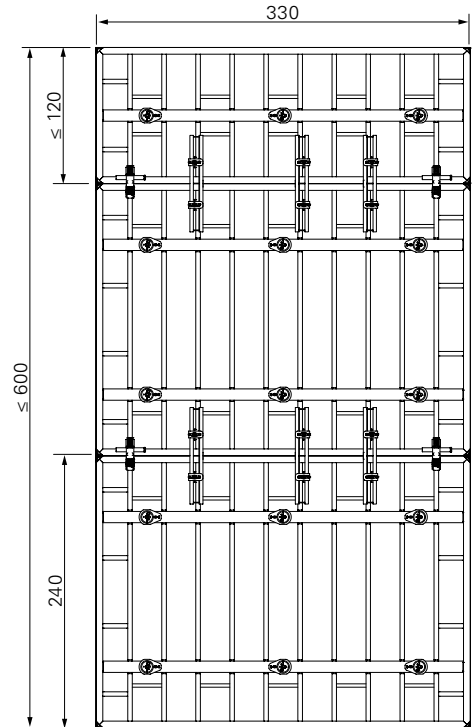


Fig. C12.03b

Assembly

- The assembly surface must be level.
- Place timbers or planks in position as support.
- Pre-assemble extension units in a horizontal position, with the formlining facing downwards.



For additional extension possibilities, number and arrangement of Alignment Coupler BFD, Compensation Waler MAR 85-3 as well Tie MX 15 – see MAXIMO poster.

Erection with the crane (Fig. C12.04)



Warning

Risk of injury!

- ⇒ Do not exceed the permissible load-bearing capacity of the Lifting Hook MAXIMO and the crane capacity!
- ⇒ Observe the Instructions for Use for the Lifting Hook MAXIMO 1.5 t!

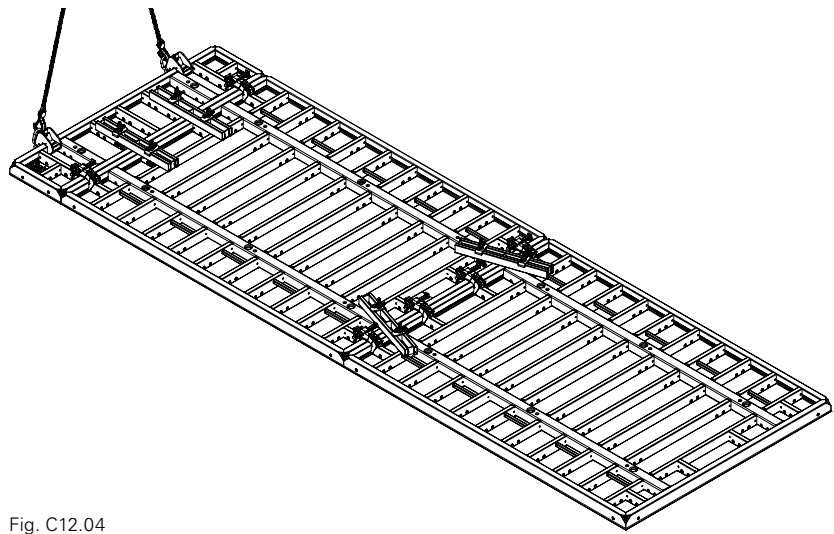


Fig. C12.04

Shaft Corner MXSE 330

Two Shaft Corners MXSE 330 and
two Inside Corners MXI 330 x 50/20

Internal shaft wall

Pos. Components

20	Alignment Coupler BFD
84	Shaft Corner MXSE 330
121	Panel MX 330 x 30
123	Panel MX 330 x 60
124	Panel MX 330 x 90
142	Wall Thickness Compensation WDA MX 330 x width
161	Inside Corner MXI 330 x 50/20

Arrangement of the Alignment Couplers BFD

Shown:

- Shaft dimensions: 2.30 m x 2.60 m
 - Wall thickness 25 cm
- (Fig. C13.01)

Shaft Corner MXSE 330 (84)
(Fig. C13.01a)

Inside Corner MXI 330 x 50/20 (161)
(Fig. C13.01b)

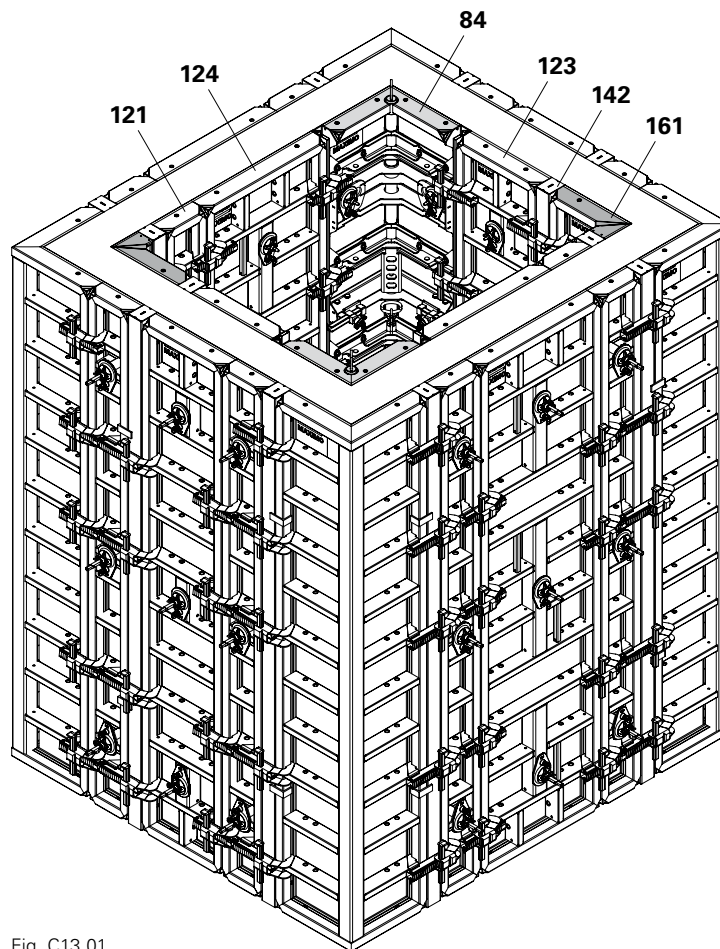


Fig. C13.01

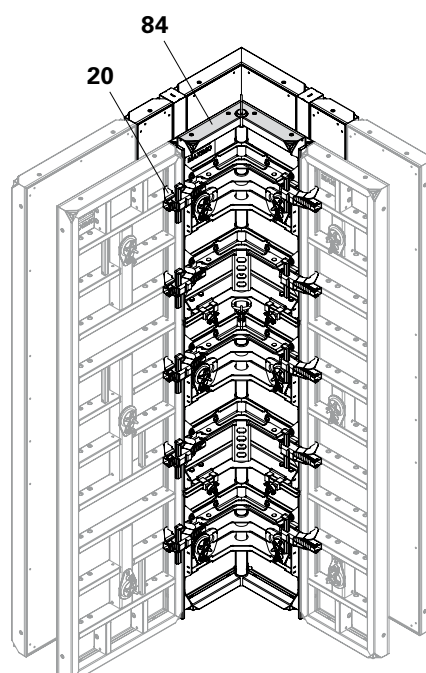


Fig. C13.01a

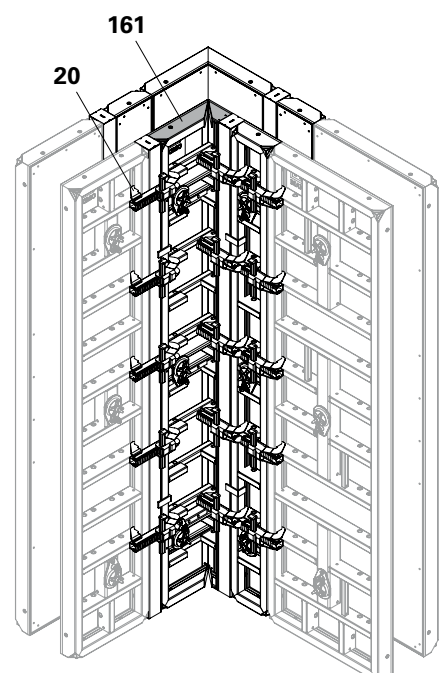


Fig. C13.01b

Four Shaft Corners MXSE 330

Internal shaft wall

Pos. Components

20	Alignment Coupler BFD
84	Shaft Corner MXSE 330
125	Panel MX 330 x 120

Arrangement of the Alignment Couplers BFD

Shown:

- Shaft dimensions: 2.90 x 2.90 m
 - Wall thickness 25 cm
- (Fig. C13.02)

Shaft Corner MXSE 330 (84)
(Fig. C13.02a)

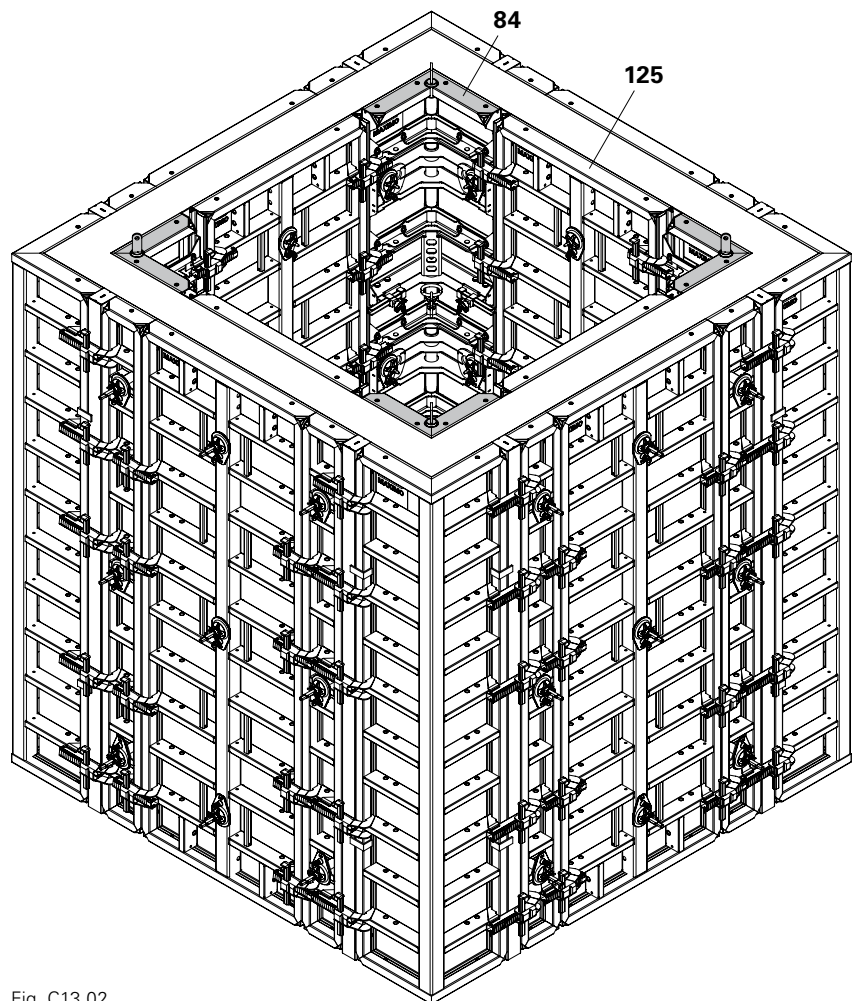


Fig. C13.02

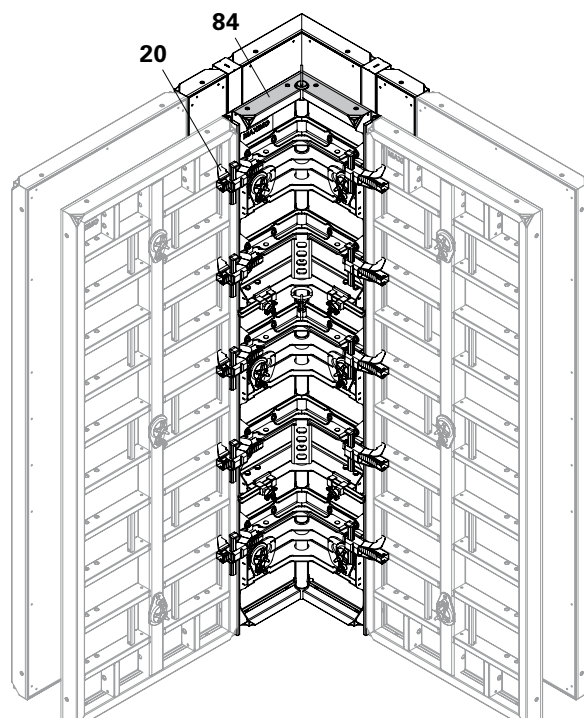


Fig. C13.02a

MAXIMO MX 15 Panel Formwork

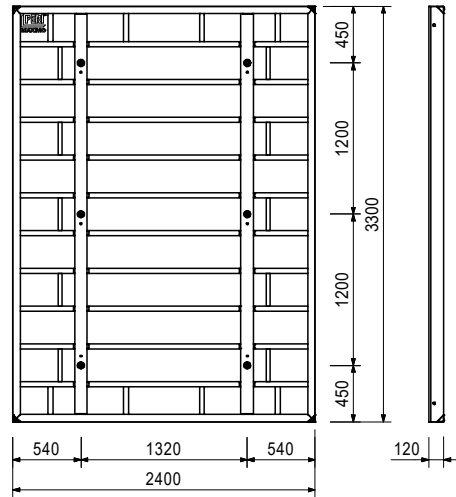
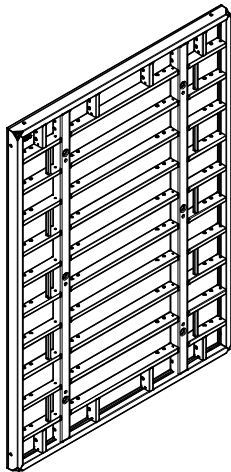


Item no. Weight kg

114426 408.000

Panel MX 330 x 240

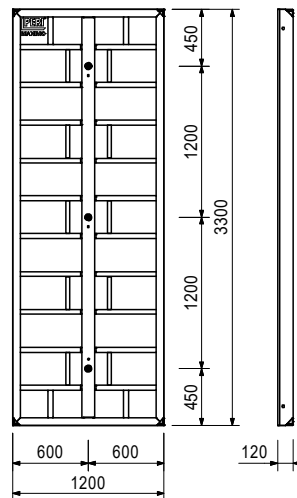
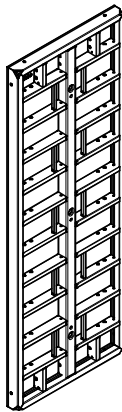
7.920 m². Panel with 18 mm plywood.



114248 226.000

Panel MX 330 x 120

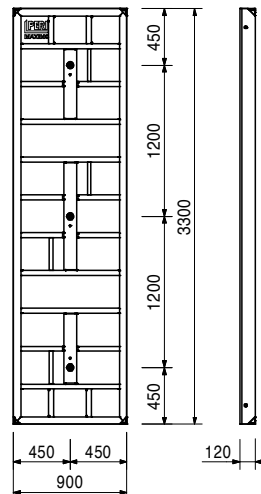
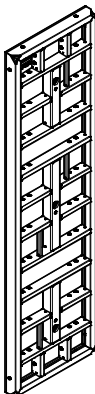
3.960 m². Panel with 18 mm plywood.



114258 171.000

Panel MX 330 x 90

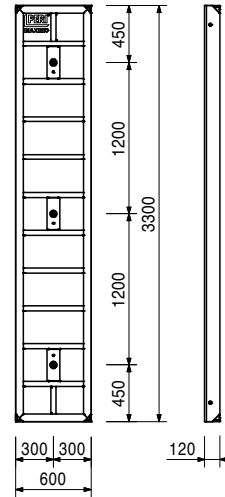
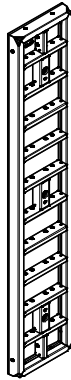
2.970 m². Panel with 18 mm plywood.



MAXIMO MX 15 Panel Formwork

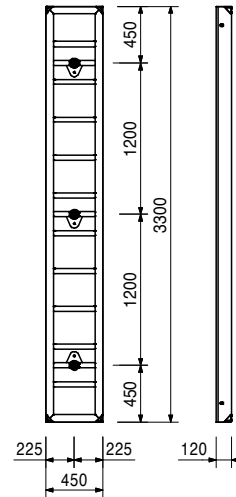
Item no.	Weight kg
114445	118.000

Panel MX 330 x 60
1.980 m². Panel with 18 mm plywood.



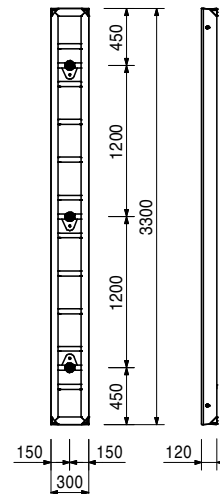
114452	99.800
--------	--------

Panel MX 330 x 45
1.485 m². Panel with 18 mm plywood.



114457	78.600
--------	--------

Panel MX 330 x 30
0.990 m². Panel with 18 mm plywood.



MAXIMO MX 15 Panel Formwork



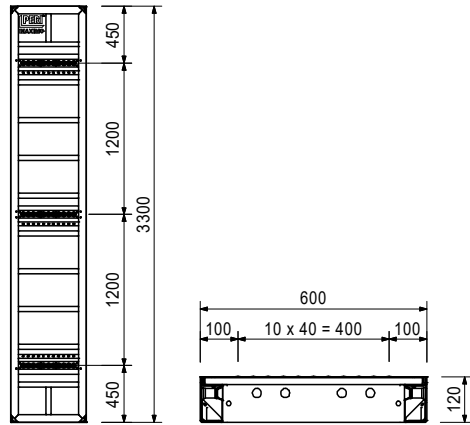
Item no.	Weight kg
114464	141.000

Multi Panel MXM 330 x 60

1.980 m². Panel with 18 mm plywood.
For oblique angles, wall connections etc.

Complete with

33 pc. 124895 PVC Plug MXM 15 Ø 18.3



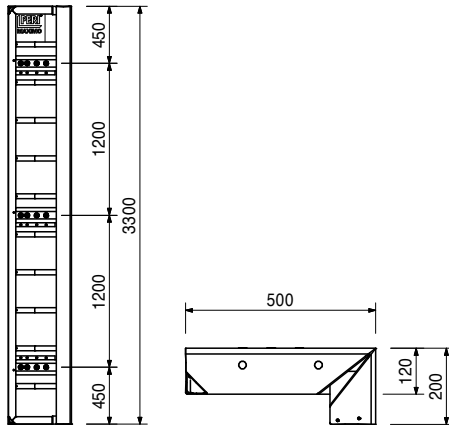
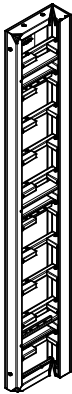
115338	136.000
--------	---------

Inside Corner MXI 330 x 50/20

2.310 m². Panel with 18 mm plywood.
For 90° internal corners.

Complete with

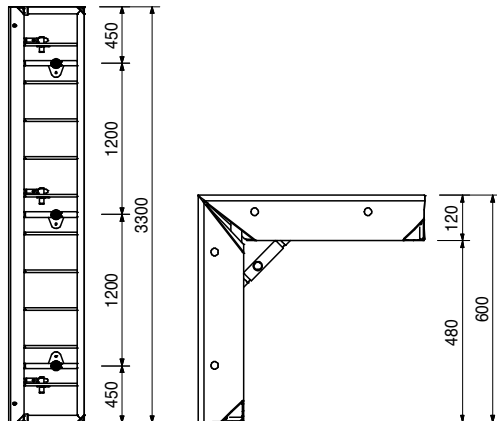
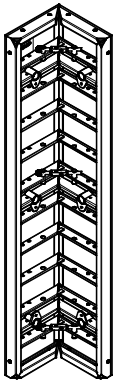
12 pc. 124895 PVC Plug MXM 15 Ø 18.3



114470	199.000
--------	---------

Inside Corner MXI 330 x 60

3.960 m². Panel with 18 mm plywood.
For 90° internal corners.



MAXIMO MX 15 Panel Formwork

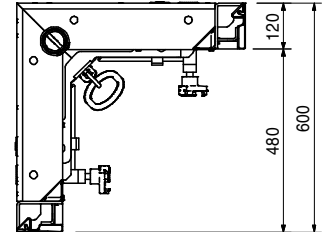
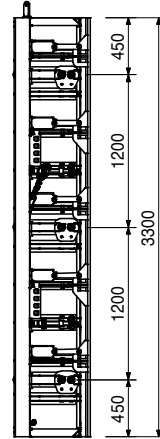
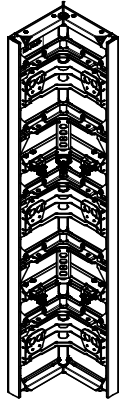
Item no.	Weight kg
117913	401.000

Shaft Corner MXSE 330

Panel for forming 90° inside corners along with striking and moving complete internal shaft formwork units.

Technical Data

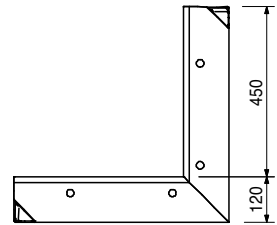
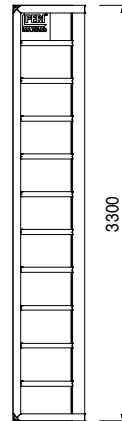
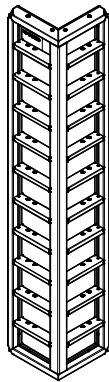
Permissible load-bearing point capacity 2.0 t.



114478	190.000
--------	---------

Outside Corner MXA 330 x 45

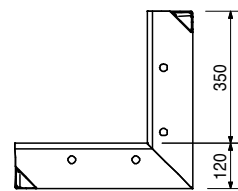
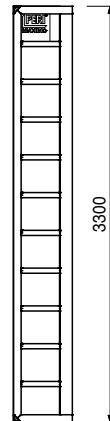
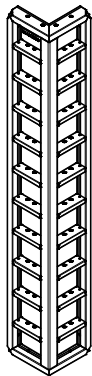
2.970 m². Panel with 18 mm plywood. For 90° external corners.



114486	168.000
--------	---------

Outside Corner MXA 330 x 35

2.310 m². Panel with 18 mm plywood. For 90° external corners.



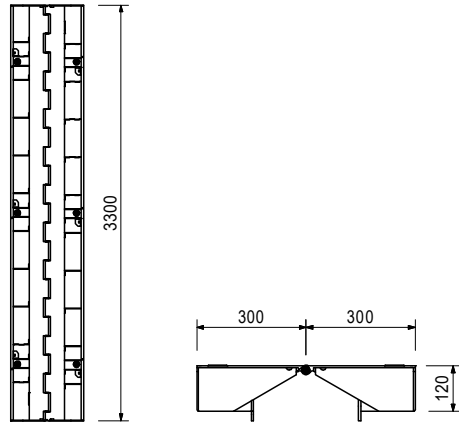
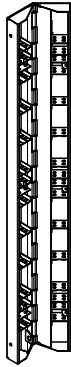
MAXIMO MX 15 Panel Formwork



Item no.	Weight kg
114583	88.800

Articulated Corner MXGI 330

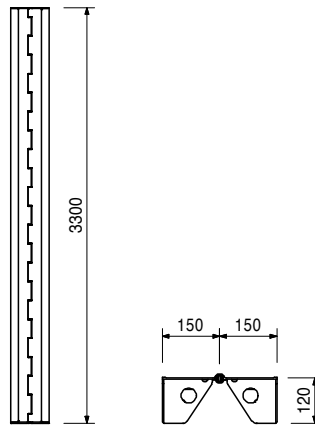
1.980 m². Made of aluminium, for oblique angles from 75° upwards, internal.



114607	51.100
--------	--------

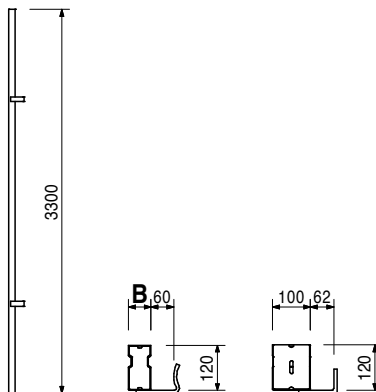
Articulated Corner MXGA 330

0.990 m². Made of aluminium, for oblique angles from 75° upwards, external.



Wall Thickness Compensations WDA MX 330		B
114842	17.800	40
114826	18.900	50
114846	20.200	60
114394	12.100	100

For adjusting to wall thicknesses.

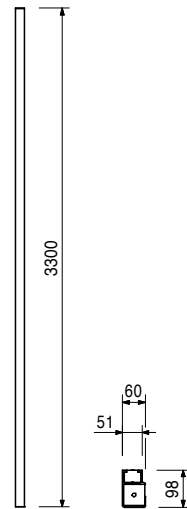


MAXIMO MX 15 Panel Formwork



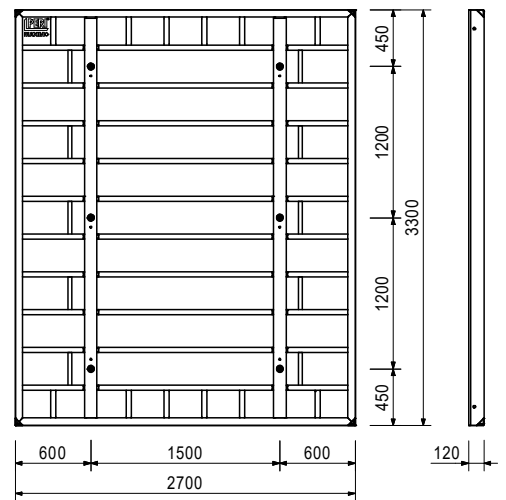
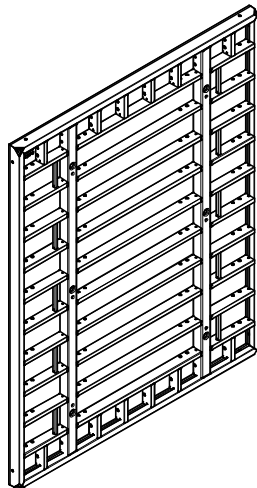
Item no.	Weight kg
101829	9.820

Filler Profile TPP 330, Alu
For compensation with 21 mm filler plates.



116454	446.000
--------	---------

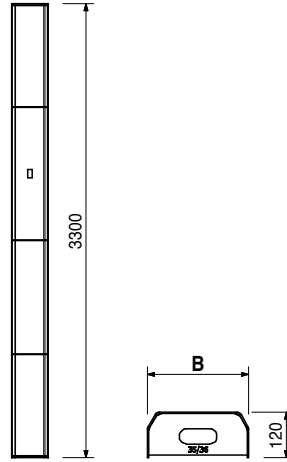
Panel MX 330 x 270
8.910 m². Panel with 18 mm plywood.



MAXIMO MX 15 Panel Formwork

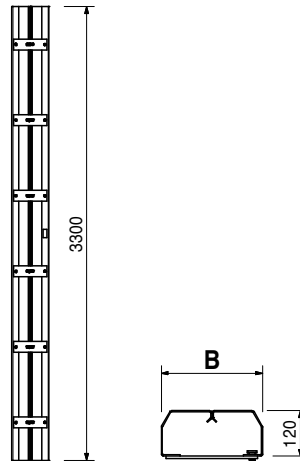
Item no.	Weight kg		B
131152	32.400	Stopend Panel TRIO MT without waterstop	118
131155	37.200	Stopend Panel TRIO MT 330 x 20	158
131158	44.500	Stopend Panel TRIO MT 330 x 30	218
131161	50.500	Stopend Panel TRIO MT 330 x 35/36	268

Without waterstop bar installation for stopend formwork.



Item no.	Weight kg		B
131165	35.600	Stopend Panel TRIO MT with waterstop	118
131169	40.900	Stopend Panel TRIO MTF 330 x 20	158
131173	46.900	Stopend Panel TRIO MTF 330 x 30	218
131177	52.000	Stopend Panel TRIO MTF 330 x 35/36	268

Centre piece with waterstop bar installation for stopend formwork.



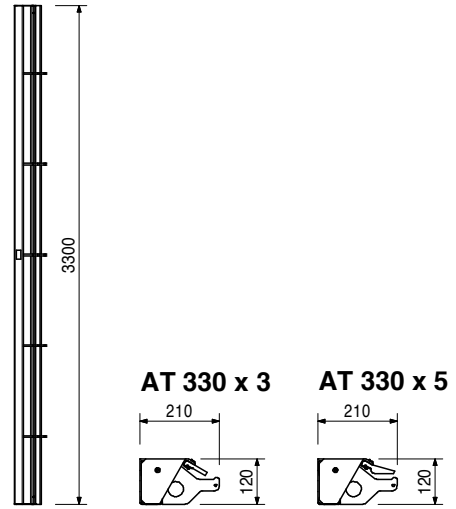
MAXIMO MX 15 Panel Formwork



Item no.	Weight kg
131147	21.000
131149	23.200

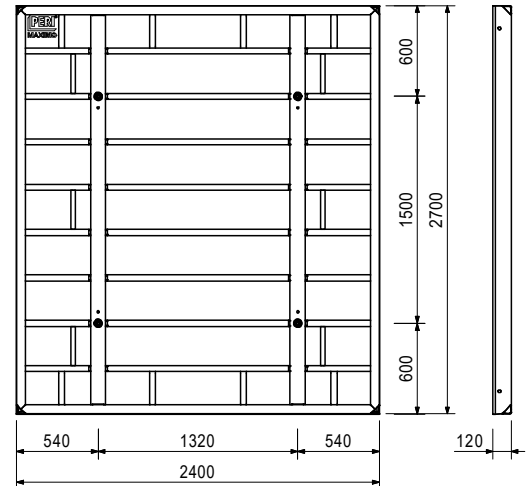
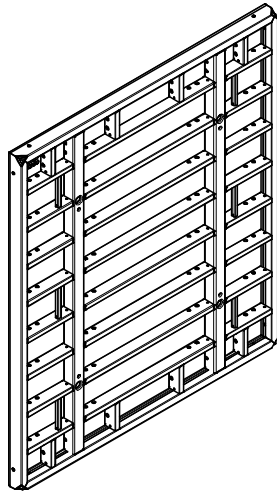
Stopend Panel TRIO AT
Stopend Panel TRIO AT 330 x 3
Stopend Panel TRIO AT 330 x 5
 External piece for stopend formwork.

Note
 Concrete cover approx. 30 or 50 mm.



112006	336.000
--------	---------

Panel MX 270 x 240
 6.480 m². Panel with 18 mm plywood.



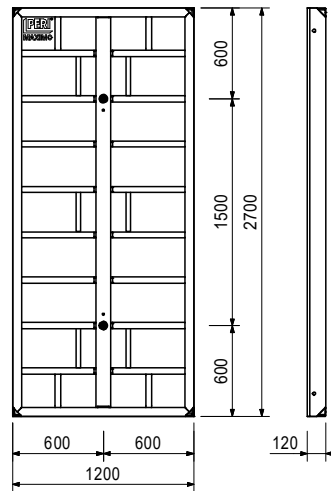
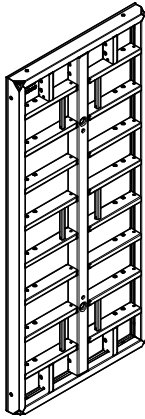
MAXIMO MX 15 Panel Formwork

Item no. Weight kg

112022 186.000

Panel MX 270 x 120

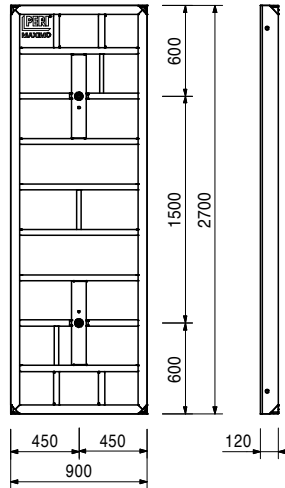
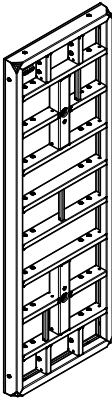
3.240 m². Panel with 18 mm plywood.



112045 134.000

Panel MX 270 x 90

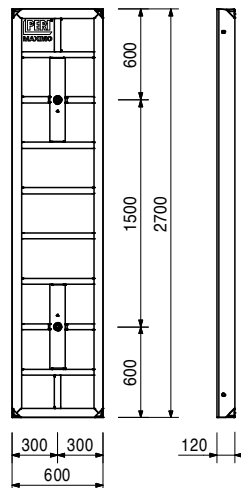
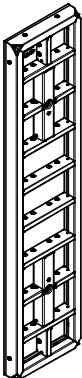
2.430 m². Panel with 18 mm plywood.



112200 104.000

Panel MX 270 x 60

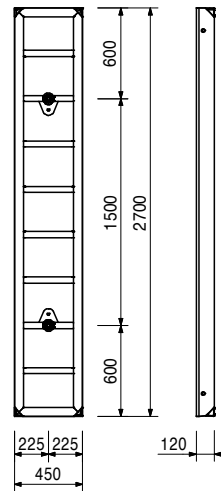
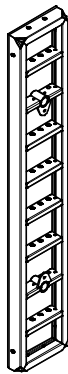
1.620 m². Panel with 18 mm plywood.



MAXIMO MX 15 Panel Formwork

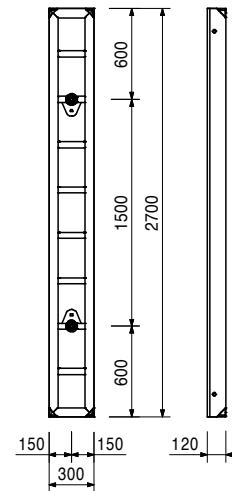
Item no.	Weight kg
112078	77.500

Panel MX 270 x 45
1.215 m². Panel with 18 mm plywood.



112090	61.800
--------	--------

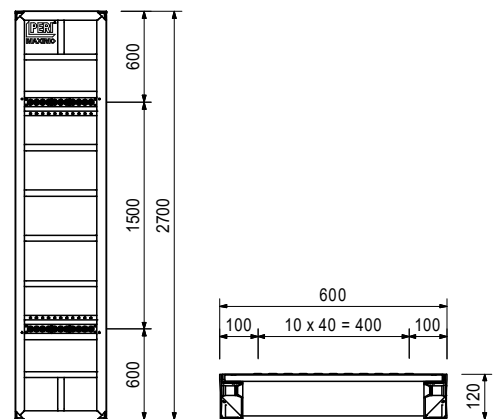
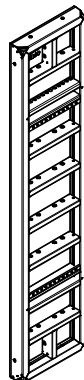
Panel MX 270 x 30
0.810 m². Panel with 18 mm plywood.



112849	108.000
--------	---------

Multi Panel MXM 270 x 60
1.620 m². Panel with 18 mm plywood.
For oblique angles, wall connections etc.

Complete with
22 pc. 124895 PVC Plug MXM 15 Ø 18.3



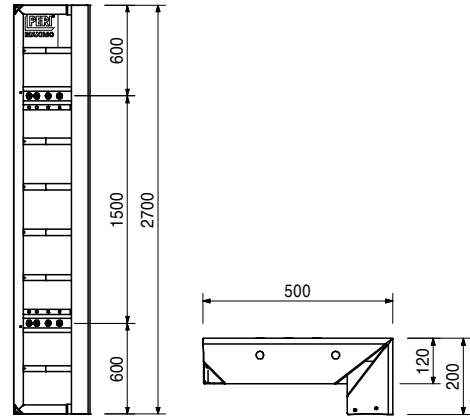
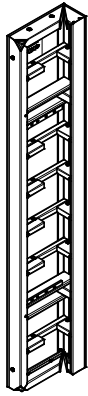
MAXIMO MX 15 Panel Formwork



Item no.	Weight kg
115255	103.000

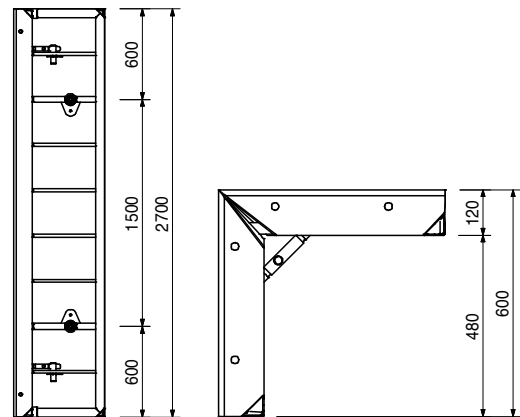
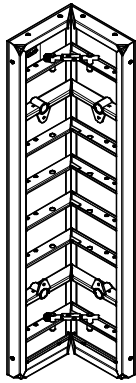
Inside Corner MXI 270 x 50/20
 1.890 m². Panel with 18 mm plywood.
 For 90° internal corners.

Complete with
 8 pc. 124895 PVC Plug MXM 15 Ø 18.3



112419	150.000
--------	---------

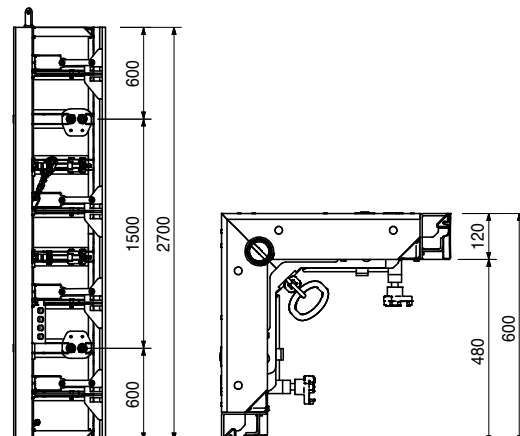
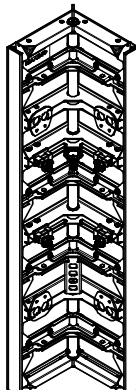
Inside Corner MXI 270 x 60
 3.240 m². Panel with 18 mm plywood.
 For 90° internal corners.



117914	305.000
--------	---------

Shaft Corner MXSE 270
 Panel for forming 90° inside corners along with striking and moving complete internal shaft formwork units.

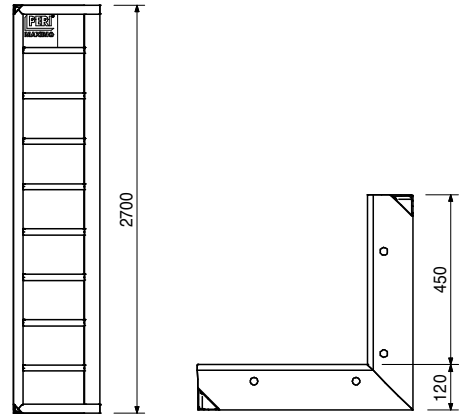
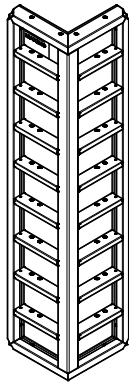
Technical Data
 Permissible load-bearing point capacity 2.0 t.



MAXIMO MX 15 Panel Formwork

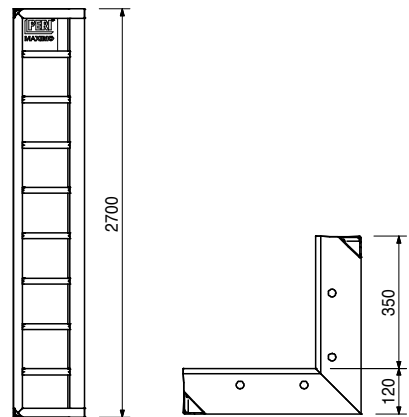
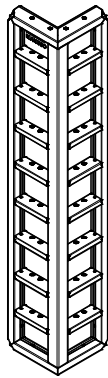
Item no.	Weight kg
112806	157.000

Outside Corner MXA 270 x 45
 2.430 m². Panel with 18 mm plywood.
 For 90° external corners.



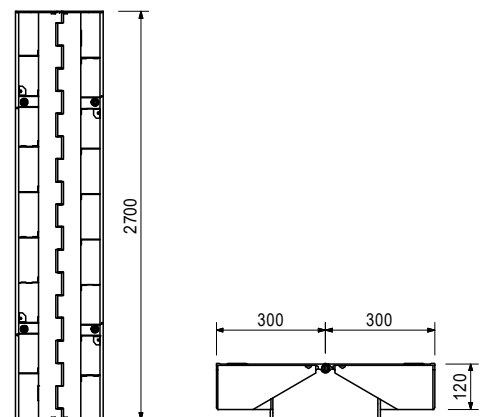
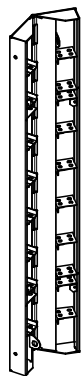
112667	139.000
--------	---------

Outside Corner MXA 270 x 35
 1.890 m². Panel with 18 mm plywood.
 For 90° external corners.



113203	69.400
--------	--------

Articulated Corner MXGI 270
 1.620 m². Made of aluminium, for oblique angles
 from 75° upwards, internal.

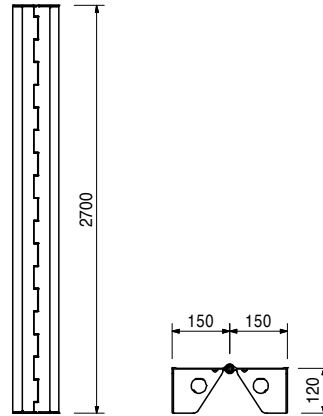


MAXIMO MX 15 Panel Formwork

Item no.	Weight kg
111872	41.800

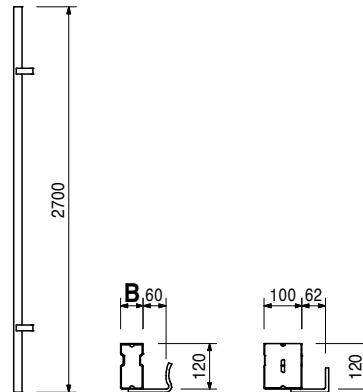
Articulated Corner MXGA 270

0.810 m². Made of aluminium, for oblique angles from 75° upwards, external.



		Wall Thickness Compensations WDA MX 270	B
114165	14.700	Wall Thickness Comp. WDA MX 270 x 4	40
114186	15.700	Wall Thickness Comp. WDA MX 270 x 5	50
114174	16.800	Wall Thickness Comp. WDA MX 270 x 6	60
114128	10.000	Wall Thickness Comp. WDA MX 270 x 10, Alu	100

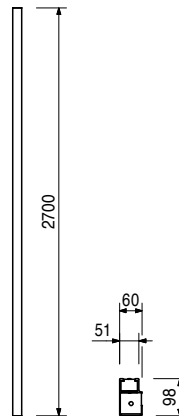
For adjusting to wall thicknesses.



101813	8.040
--------	-------

Filler Profile TPP 270, Alu

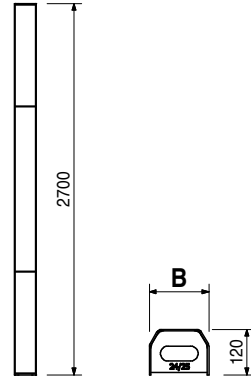
For compensation with 21 mm filler plates.



MAXIMO MX 15 Panel Formwork

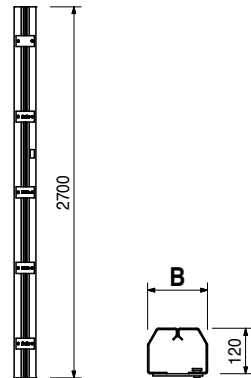
Item no.	Weight kg		B
023061	26.500	Stopend Panels TRIO MT without waterstop	118
023062	30.400	Stopend Panel TRIO MT 270 x 20	158
023064	36.300	Stopend Panel TRIO MT 270 x 24/25	218
023065	41.300	Stopend Panel TRIO MT 270 x 30	268

Centre piece without waterstop bar installation for stopend formwork.



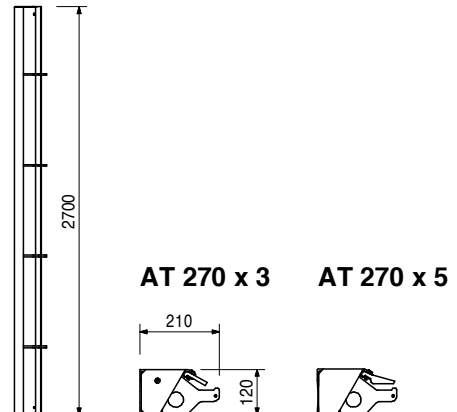
Item no.	Weight kg		B
023074	29.200	Stopend Panels TRIO MTF with waterstop	118
023075	33.400	Stopend Panel TRIO MTF 270 x 20	158
023077	38.600	Stopend Panel TRIO MTF 270 x 30	218
023076	42.500	Stopend Panel TRIO MTF 270 x 35/36	268

Centre piece with waterstop bar installation for stopend formwork.



023060	17.200	Stopend Panels TRIO AT	Note Concrete cover approx. 30 or 50 mm.
105953	19.000	Stopend Panel TRIO AT 270 x 3	
		Stopend Panel TRIO AT 270 x 5	

External piece for stopend formwork.



MAXIMO MX 15 Panel Formwork

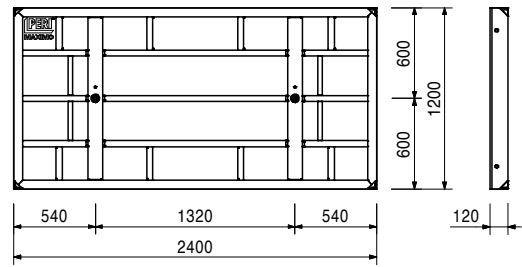
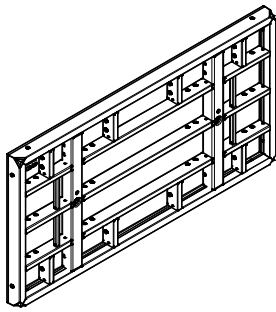


Item no. Weight kg

112104 165.000

Panel MX 120 x 240

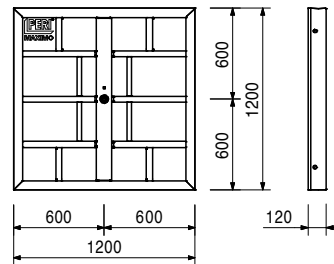
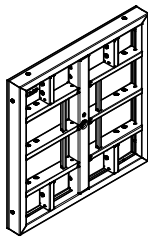
2.880 m². Panel with 18 mm plywood.



112143 90.800

Panel MX 120 x 120

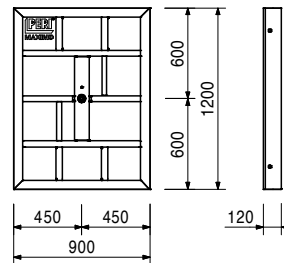
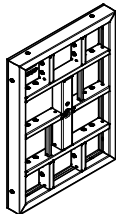
1.440 m². Panel with 18 mm plywood.



112152 67.700

Panel MX 120 x 90

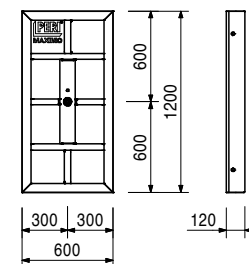
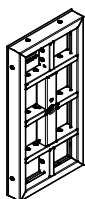
1.080 m². Panel with 18 mm plywood.



112221 51.200

Panel MX 120 x 60

0.720 m². Panel with 18 mm plywood.

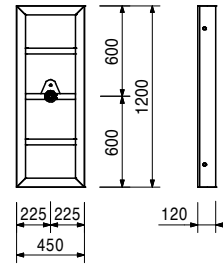
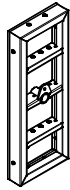


MAXIMO MX 15 Panel Formwork



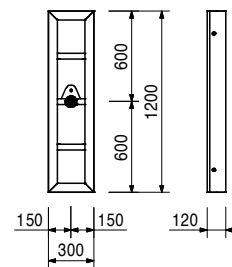
Item no.	Weight kg
112232	37.100

Panel MX 120 x 45
0.540 m². Panel with 18 mm plywood.



112239	28.900
--------	--------

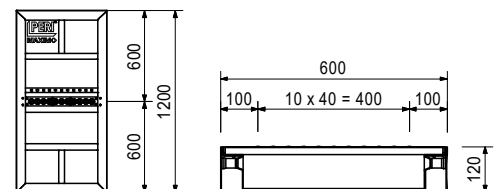
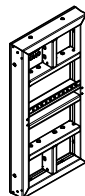
Panel MX 120 x 30
0.360 m². Panel with 18 mm plywood.



112850	53.400
--------	--------

Multi Panel MXM 120 x 60
0.720 m². Panel with 18 mm plywood.
For oblique angles, wall connections etc.

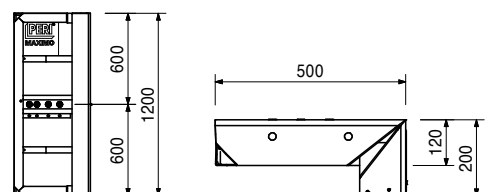
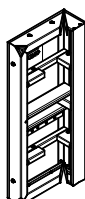
Complete with
11 pc. 124895 PVC Plug MXM 15 Ø 18.3



115299	48.800
--------	--------

Inside Corner MXI 120 x 50/20
0.840 m². Panel with 18 mm plywood.
For 90° internal corners.

Complete with
4 pc. 124895 PVC Plug MXM 15 Ø 18.3

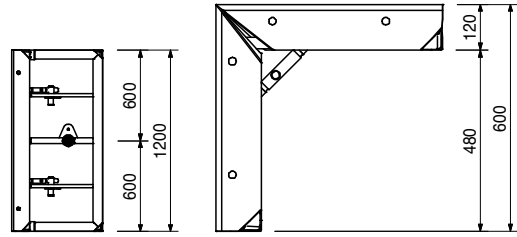
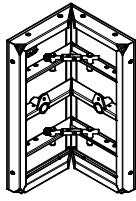


MAXIMO MX 15 Panel Formwork



Item no.	Weight kg
112689	79.500

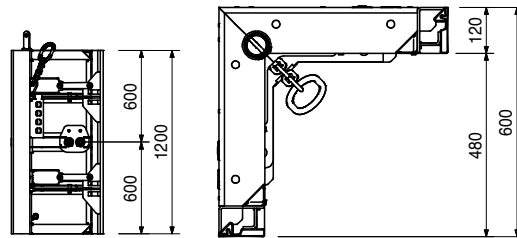
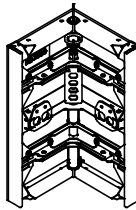
Inside Corner MXI 120 x 60
 1.440 m². Panel with 18 mm plywood.
 For 90° internal corners.



117915	139.000
--------	---------

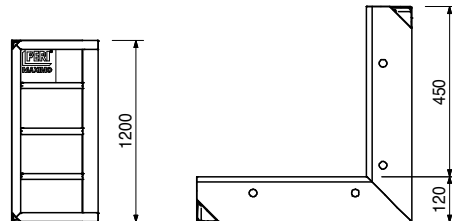
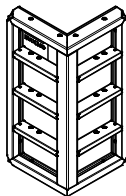
Shaft Corner MXSE 120
 Panel for forming 90° inside corners along with striking and moving complete internal shaft formwork units.

Technical Data
 Permissible load-bearing point capacity 2.0 t.



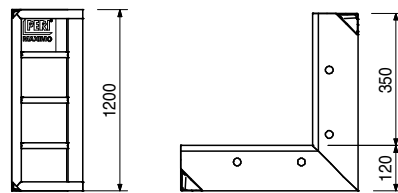
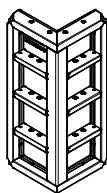
112830	74.500
--------	--------

Outside Corner MXA 120 x 45
 1.080 m². Panel with 18 mm plywood.
 For 90° external corners.



112761	65.600
--------	--------

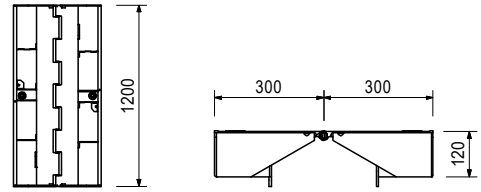
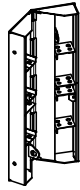
Outside Corner MXA 120 x 35
 0.840 m². Panel with 18 mm plywood.
 For 90° external corners.



Item no.	Weight kg
113246	31.200

Articulated Corner MXGI 120

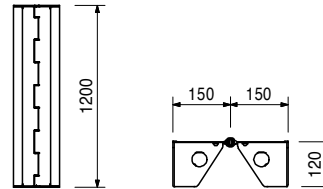
0.720 m². Made of aluminium, for oblique angles from 75° upwards, internal.



111850	19.000
--------	--------

Articulated Corner MXGA 120

0.360 m². Made of aluminium, for oblique angles from 75° upwards, external.



114212	6.420
114191	6.980
114181	7.480
114142	4.510

Wall Thickness Compensations MX 120

Wall Thickness Comp. MX 120 x 4

Wall Thickness Comp. MX 120 x 5

Wall Thickness Comp. MX 120 x 6

Wall Thickness Comp. MX 120 x 10, Alu

For adjusting to wall thicknesses.

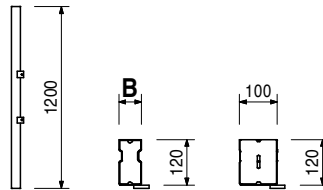
B

40

50

60

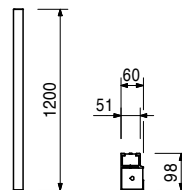
100



101823	3.590
--------	-------

Filler Profile TPP 120, Alu

For compensation with 21 mm filler plates.



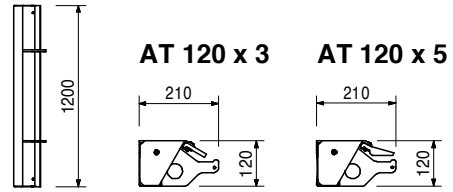
MAXIMO MX 15 Panel Formwork



Item no.	Weight kg
023067	7.790
105978	8.590

Stopend Panels TRIO AT
Stopend Panel TRIO AT 120 x 3
Stopend Panel TRIO AT 120 x 5
 External piece for stopend formwork.

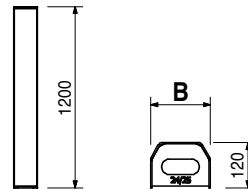
Note
 Concrete cover approx. 30 mm.



023068	11.800
023069	13.500
023071	16.300
023072	18.500

Stopend Panels TRIO MT
Stopend Panel TRIO MT 120 x 20
Stopend Panel TRIO MT 120 x 24/25
Stopend Panel TRIO MT 120 x 30
Stopend Panel TRIO MT 120 x 35/36
 Centre piece without waterstop bar installation for stopend formwork.

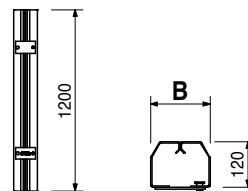
B
 118
 158
 218
 268



023081	12.800
023080	14.700
023078	16.800
023079	18.600

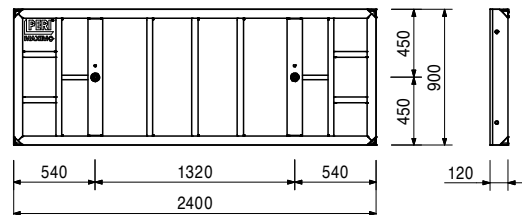
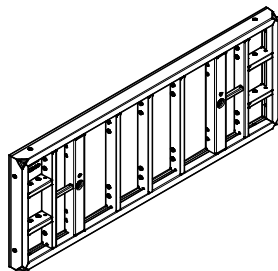
Stopend Panels TRIO MTF
Stopend Panel TRIO MTF 120 x 20
Stopend Panel TRIO MTF 120 x 24/25
Stopend Panel TRIO MTF 120 x 30
Stopend Panel TRIO MTF 120 x 35/36
 Centre piece with waterstop bar installation for stopend formwork.

B
 118
 158
 218
 268



112115	120.000
--------	---------

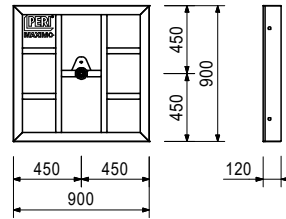
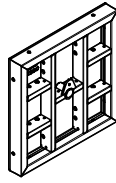
Panel MX 90 x 240
 2.160 m². Panel with 18 mm plywood.



MAXIMO MX 15 Panel Formwork

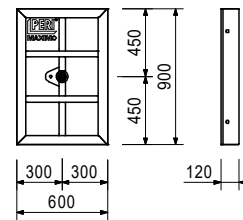
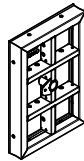
Item no.	Weight kg
112252	48.900

Panel MX 90 x 90
0.810 m². Panel with 18 mm plywood.



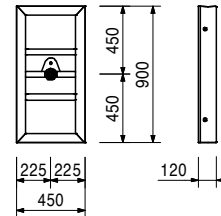
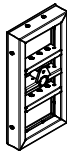
112259	36.600
--------	--------

Panel MX 90 x 60
0.540 m². Panel with 18 mm plywood.



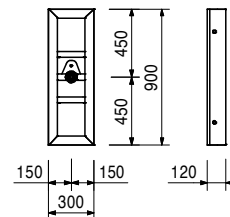
112265	31.100
--------	--------

Panel MX 90 x 45
0.405 m². Panel with 18 mm plywood.



112271	23.400
--------	--------

Panel MX 90 x 30
0.270 m². Panel with 18 mm plywood.



MAXIMO MX 15 Panel Formwork



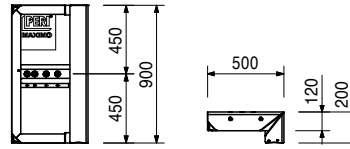
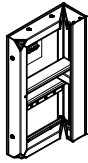
Item no.	Weight kg
115307	36.400

Inside Corner MXI 90 x 50/20

0.630 m². Panel with 18 mm plywood.
For 90° internal corners.

Complete with

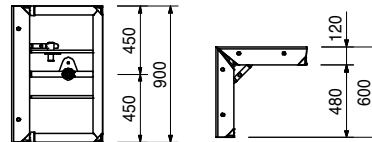
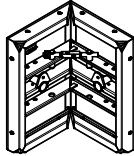
4 pc. 124895 PVC Plug MXM 15 Ø 18.3



112715	64.600
--------	--------

Inside Corner MXI 90 x 60

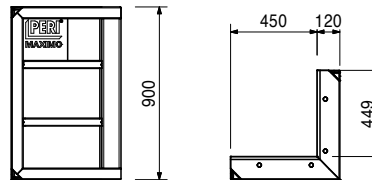
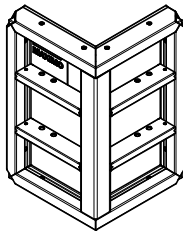
1.080 m². Panel with 18 mm plywood.
For 90° internal corners.



126923	58.000
--------	--------

Outside Corner MXA 90 x 45

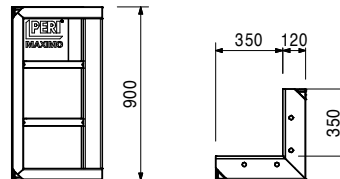
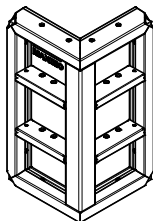
0.808 m². Panel with 18 mm plywood. For 90°
external corners.



126917	50.800
--------	--------

Outside Corner MXA 90 x 35

0.630 m². Panel with 18 mm plywood. For 90°
external corners.



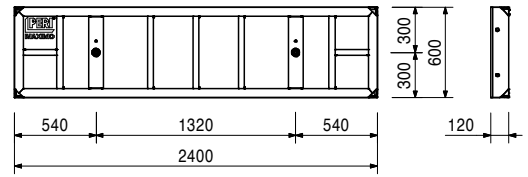
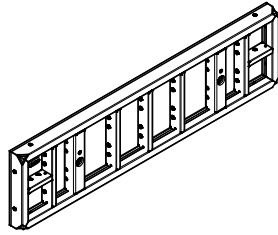
MAXIMO MX 15 Panel Formwork



Item no.	Weight kg
112126	89.100

Panel MX 60 x 240

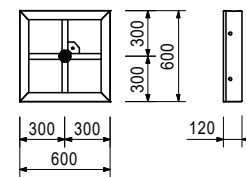
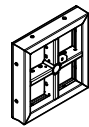
1.440 m². Panel with 18 mm plywood.



112280	28.400
--------	--------

Panel MX 60 x 60

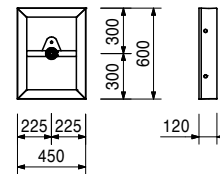
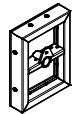
0.360 m². Panel with 18 mm plywood.



112286	21.900
--------	--------

Panel MX 60 x 45

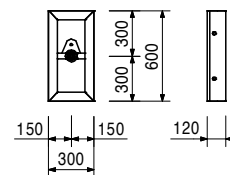
0.270 m². Panel with 18 mm plywood.



112292	16.200
--------	--------

Panel MX 60 x 30

0.180 m². Panel with 18 mm plywood.



115315	29.600
--------	--------

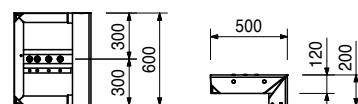
Inside Corner MXI 60 x 50/20

0.420 m². Panel with 18 mm plywood.
For 90° internal corners.



Complete with

4 pc. 124895 PVC Plug MXM 15 Ø 18.3

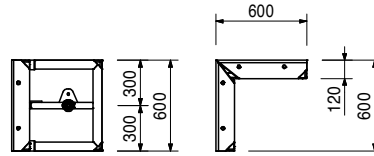
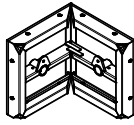


MAXIMO MX 15 Panel Formwork



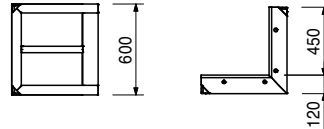
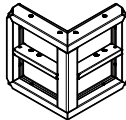
Item no.	Weight kg
112726	44.000

Inside Corner MXI 60 x 60
 0.720 m². Panel with 18 mm plywood.
 For 90° internal corners.



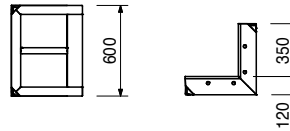
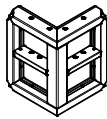
112837	41.300
--------	--------

Outside Corner MXA 60 x 45
 0.540 m². Panel with 18 mm plywood.
 For 90° external corners.



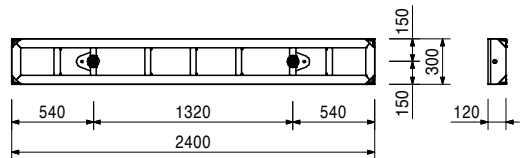
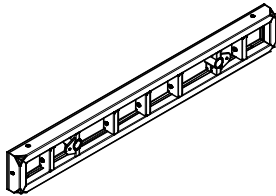
112778	36.000
--------	--------

Outside Corner MXA 60 x 35
 0.420 m². Panel with 18 mm plywood.
 For 90° external corners.



112133	55.700
--------	--------

Panel MX 30 x 240
 0.720 m². Panel with 18 mm plywood.

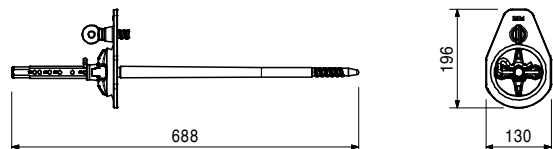
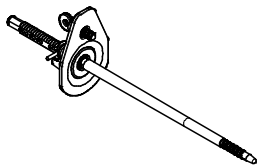


113847	4.030
--------	-------

Tie MX 15, 15 – 25
 For wall thicknesses 15 – 25 cm.

Note
 Spray with release agent before every use to ensure easier striking.

Technical Data
 Permissible tension force 100 kN.



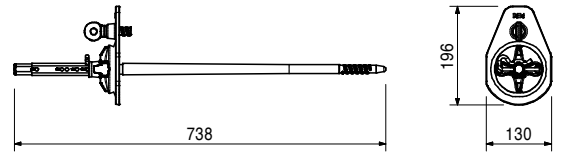
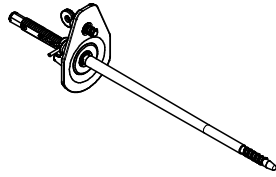
MAXIMO MX 15 Panel Formwork

Item no.	Weight kg
112387	4.170

Tie MX 15, 20 – 30
For wall thicknesses 20 – 30 cm.

Note
Spray with release agent before every use to ensure easier striking.

Technical Data
Permissible tension force 100 kN.

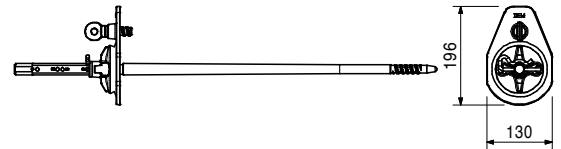
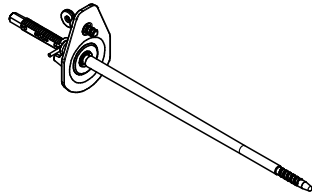


112464	4.430
--------	-------

Tie MX 15, 30 – 40
For wall thicknesses 30 – 40 cm.

Note
Spray with release agent before every use to ensure easier striking.

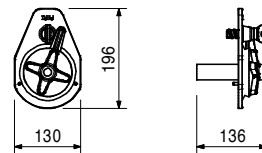
Technical Data
Permissible tension force 100 kN.



112386	2.580
--------	-------

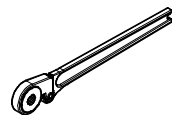
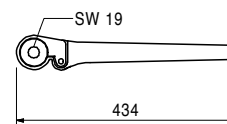
Wingnut MX 15
Counter nut for Tie MX.

Technical Data
Permissible tension force 100 kN.



116841	1.450
--------	-------

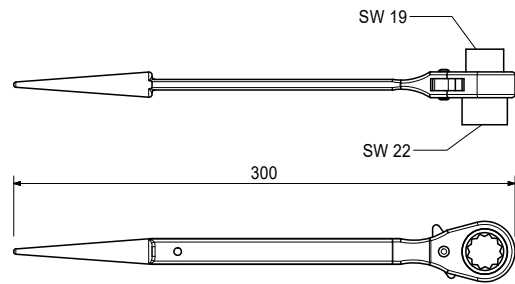
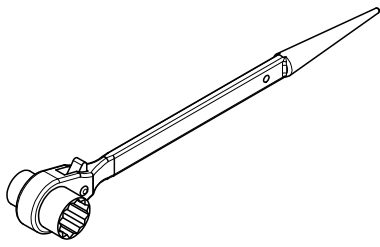
Tie Spanner MX 15
For easy release of the MX Tie.



Item no. Weight kg

796061 0.450

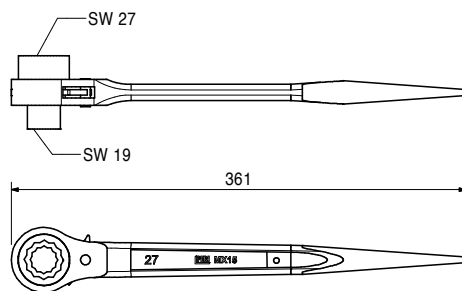
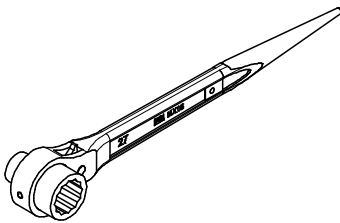
Scaffold Builders Ratchet



130798

0.800

Ratchet MX 15



023020

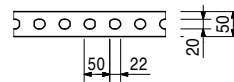
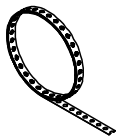
0.676

Perforated Foundation Tie, 25 m

For use with Foundation Tie Clamp TRIO, DOMINO, LIWA and HANDSET.

Technical Data

Permissible tension force 12.9 kN.

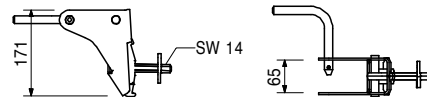
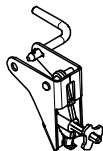


023010

2.330

Foundation Tie Clamp TRIO TLS

For anchoring foundation formwork in combination with the Perforated Foundation Tie.

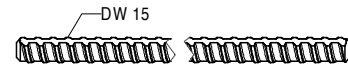
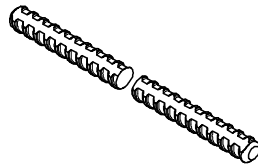


Item no. Weight kg

201002	1.440	Tie Rod DW 15 Tie Rod DW 15, l = 6.00 m
--------	-------	--

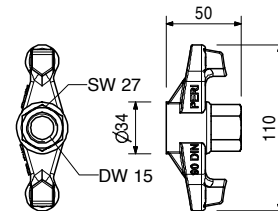
Note
Non-weldable! Take official Approval into consideration!

Technical Data
Permissible tension force 100 kN.



201001	0.439	DW 15 Wingnut, galv. For anchoring with Tie Rod DW 15 and B 15.
--------	-------	---

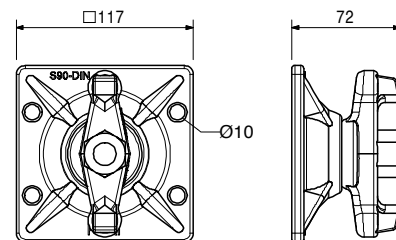
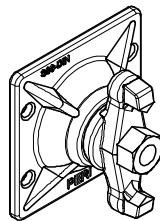
Technical Data
Permissible load 100 kN.



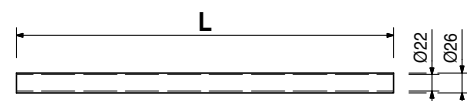
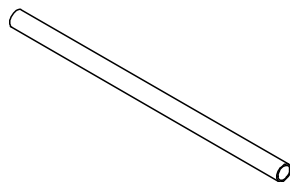
201004	1.660	DW 15 Wingnut Pivot Plate, galv. For anchoring with Tie Rod DW 15 and B 15. With pivoting captive nut. Maximum angle of tilting 8°.
--------	-------	---

Note
Wrench size SW 27.

Technical Data
Permissible load 100 kN.



065027	0.359	Spacer Tube rough DR 22, l = 2.00 m Plastic Spacer Tube for DW 15, B 15.
--------	-------	--

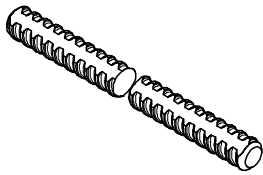


Item no.	Weight kg
030700	2.560
030050	0.000

Tie Rod DW 20
Tie Rod DW 20, spec. length
Cutting Cost Tie Rod DW 15, B 15

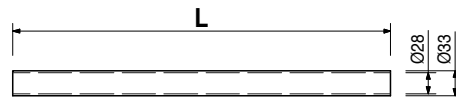
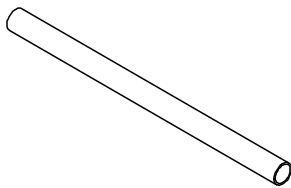
Note
 Non-weldable! Take official Approval into consideration!

Technical Data
 Permissible tension force 150 kN.



031626	0.886
--------	-------

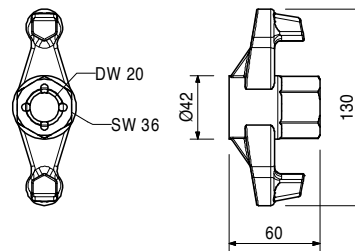
Spacer Tube rough DR 28, l = 3.00 m
 Plastic Spacer Tube for DW 20, B 20.



030990	0.786
--------	-------

Wingnut DW 20, galv.
 For anchoring with Tie Rod DW 20 and B 20.

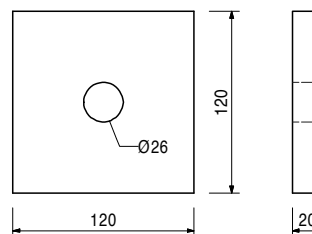
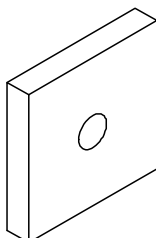
Technical Data
 Permissible load 150 kN.



030830	2.180
--------	-------

Counterplate DW 20, 120 x 120 x 20
 For anchoring with Tie Rod DW 20 and B 20.

Technical Data
 Permissible load 150 kN.

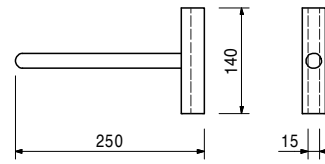
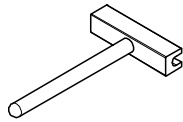


MAXIMO MX 15 Panel Formwork



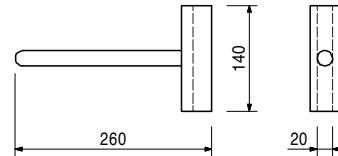
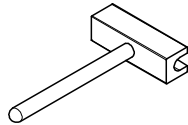
Item no.	Weight kg
031070	1.260

Tie Rod Wrench 15, galv.
For easy handling of Tie Rod DW 15.



031050	1.780
--------	-------

Tie Rod Wrench 20, galv.
For easy handling of Tie Rod DW 20.

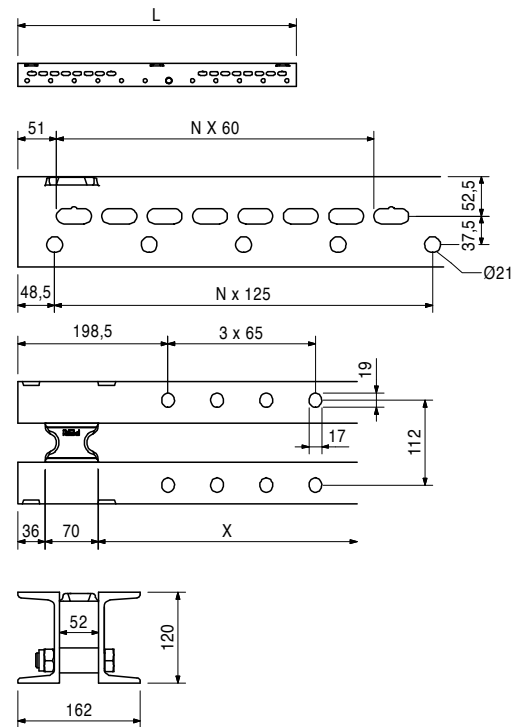
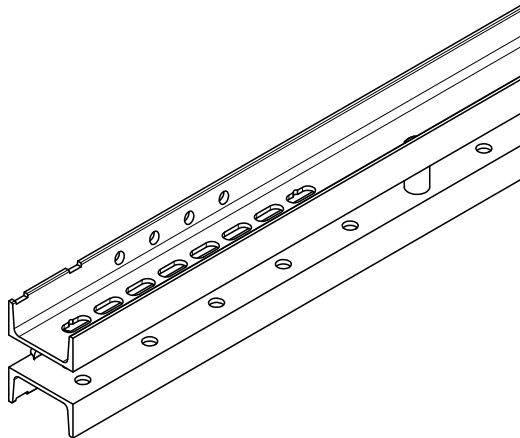


103874	30.900
103892	65.600

Steel Waler Universal SRU U120
Steel Waler Universal SRU U120, l = 1.22 m
Steel Waler Universal SRU U120, l = 2.47 m
Universal steel waler profiles with profile U120 used as waling for girder wall formwork and for diverse special applications. With adjustable spacers.

L
1222
2472

Note
Permissible load: see PERI Design Tables.



MAXIMO MX 15 Panel Formwork



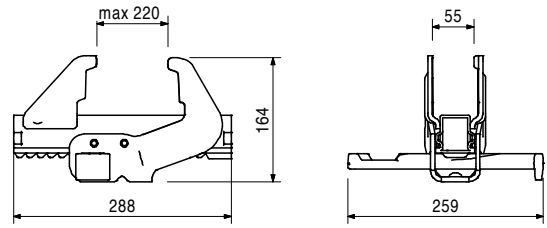
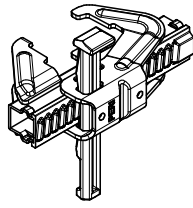
Item no.	Weight kg
023500	4.580

Alignment Coupler BFD, galv.

For all panel connections for MAXIMO, TRIO and RUNDFLEX. Fillers up to 10 cm.

Technical Data

Permissible tension force 20.0 kN.



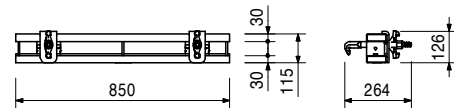
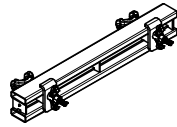
124941	14.100
--------	--------

Waler MAR 85-3

For longitudinal compensation, height extensions, stopend formwork and special applications with MAXIMO. With captive connecting components.

Technical Data

Permissible bending moment 3.9 kNm.



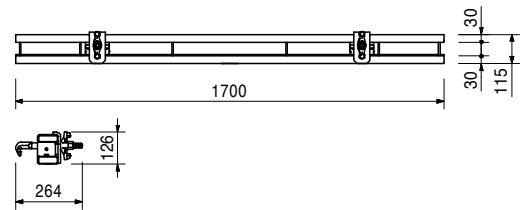
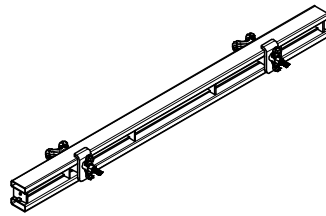
124942	23.400
--------	--------

Waler MAR 170-3

For longitudinal compensation, height extensions, stopend formwork and special applications with MAXIMO. With captive connecting components.

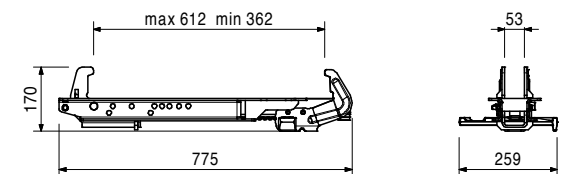
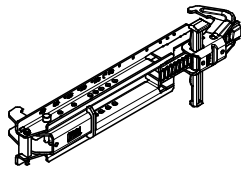
Technical Data

Permissible bending moment 3.9 kNm.



127732	11.000
--------	--------

Stopend Waler MX 15 - 40



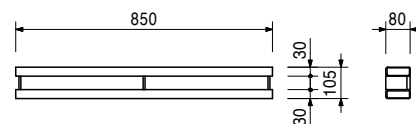
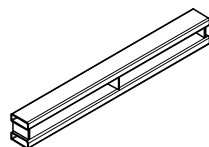
023551	8.520
--------	-------

Waler 85

Corresponds to Compensation Waler TAR 85 but without mounting hooks.

Technical Data

Permissible bending moment 4.4 kNm.



MAXIMO MX 15 Panel Formwork

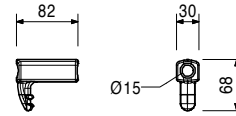
Item no.	Weight kg
023820	0.375

Hook Tie Head DW 15, galv.

For connecting accessories to MAXIMO and TRIO Panels. DW 15 thread.

Technical Data

Permissible tension force 20.0 kN.



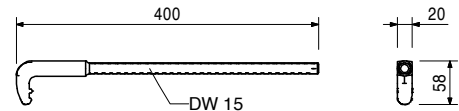
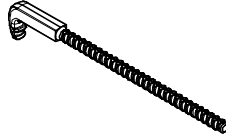
023650	0.769
--------	-------

Hook Tie DW 15, l = 400 mm, galv.

For connecting accessories to MAXIMO and TRIO Panels. DW 15 thread.

Technical Data

Permissible tension force 20.0 kN.



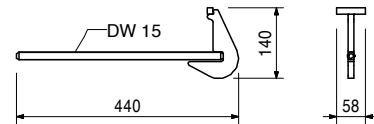
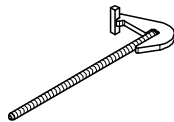
023640	1.140
--------	-------

Bulkhead Tie TS, galv.

For force application from the stopend formwork in MAXIMO and TRIO panels. DW 15 thread.

Technical Data

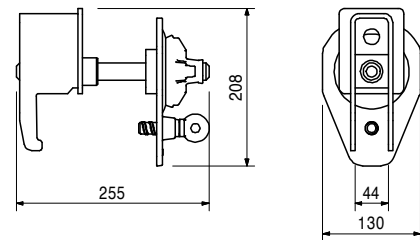
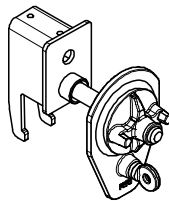
Permissible tension force 20.0 kN.



115640	5.980
--------	-------

Bulkhead Tie MX DW 20

For forming wall offsets with MAXIMO in connection with the Multi Panel MXM.



MAXIMO MX 15 Panel Formwork



Item no. Weight kg

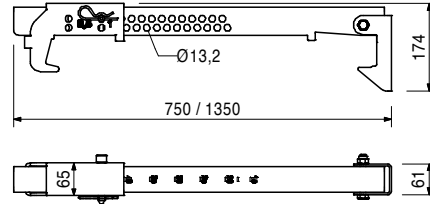
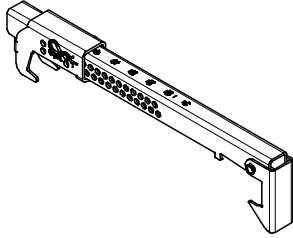
115350 6.310
123842 9.070

Tension and Compression Braces MX
Tension and Compression Brace MX 15 – 40
Tension and Compression Brace MX 15 – 100
 For use with MAXIMO and TRIO.

Complete with
 1 pc. 115331 Bolt Ø 12 x 96, galv.
 1 pc. 018060 Cotter Pin 4/1, galv.

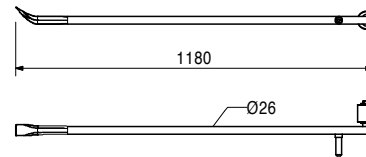
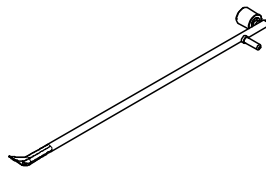
Note
 Adjustable in 0.5-cm-increments from 15 to 40 cm
 and in 0.5-cm-increments from 15 to 100 cm.

Technical Data
 Permissible tension and compressive force 9 kN.



112588 5.520

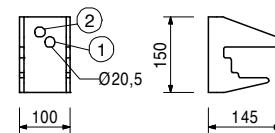
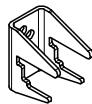
Stripping Bar TRIO



023630 2.080

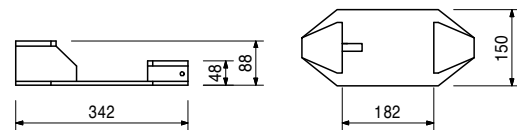
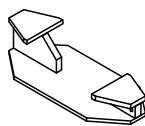
Top Tie Bracket-2 AH, galv.
 For grid-independent anchoring outside of the panel, especially for foundations and height extensions.

Technical Data
 Permissible anchor tension force:
 Hole 1 = 30 kN
 Hole 2 = 15 kN



023800 4.840

Foundation Strap TRIO
 For connecting TRIO Panels with 6 cm wide edge profiles, assembled in a "windmill" configuration.

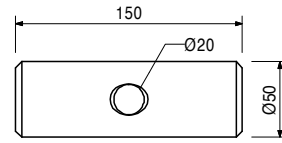
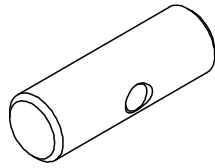


MAXIMO MX 15 Panel Formwork

Item no.	Weight kg
022030	2.170

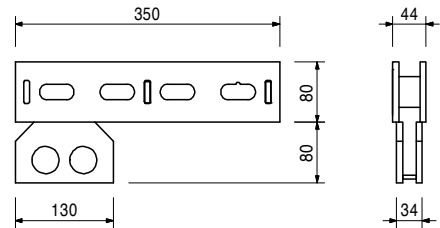
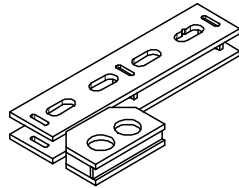
Tie Yoke, galv.
For anchoring with Tie Rod DW 15 and B 15.

Technical Data
Permissible load 90 kN.



023930	4.100
--------	-------

Waler Stop
For use with the Universal Waler 245.



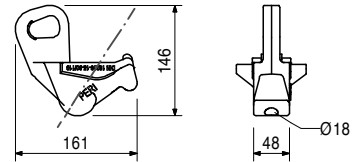
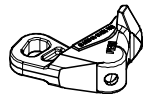
Accessories

024240	0.805
022030	2.170

Wedge KZ, galv.
Tie Yoke, galv.

024210	2.180
--------	-------

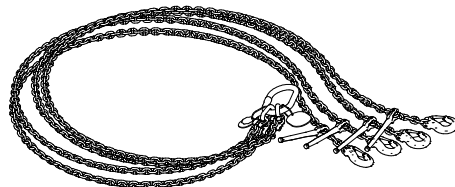
Tie Yoke SKZ
For tensioning on external corners with Steel Waler SRZ, SRU, U100 – U140 and VARIO couplings.



117321	31.000
--------	--------

Lifting Gear Combi MX
For transporting stacks of MAXIMO and TRIO Panels. For attaching Lifting Hook MAXIMO 1.5 t and Stacking Device MAXIMO.

Note
Follow Instructions for Use!



MAXIMO MX 15 Panel Formwork

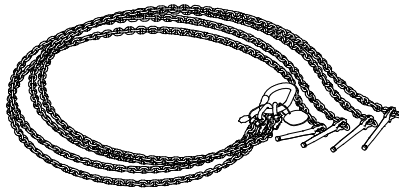
Item no.	Weight kg
117322	25.000

Lifting Gear MX

For transporting stacks of MAXIMO and TRIO Panels.

Note

Follow Instructions for Use!



Item no.	Weight kg
115168	7.460

Lifting Hook MAXIMO 1.5 t

For transporting MAXIMO and TRIO Panels.

Note

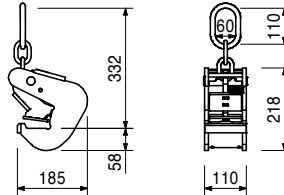
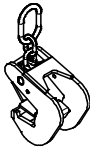
Follow Instructions for Use!

Technical Data

Permissible load-bearing capacity:

Steel elements 1.5 t

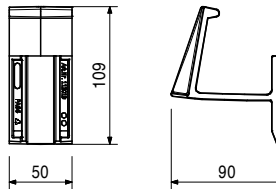
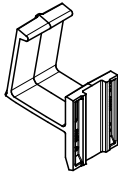
Alu elements 750 kg



Item no.	Weight kg
113019	0.062

Stacking Device MX

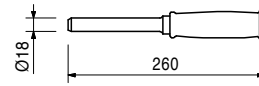
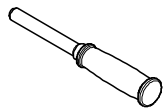
For easy stacking of MAXIMO Panels.



MAXIMO MX 15 Panel Formwork

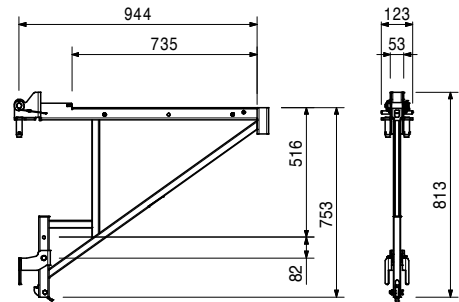
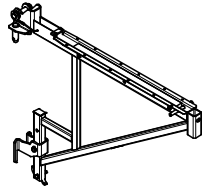
Item no.	Weight kg
023440	0.312

Lifting Pin TRIO
For easy carrying of TRIO Panels.



126356	10.200
--------	--------

Scaffold Bracket MXK
For assembly of a working and concreting scaffold with MAXIMO and TRIO.



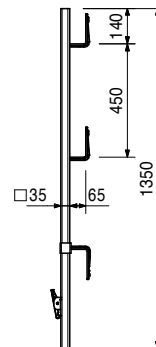
Accessories

126360	4.920
--------	-------

Guardrail Post MXK

126360	4.920
--------	-------

Guardrail Post MXK
As guardrail for MAXIMO and TRIO.



MAXIMO MX 15 Panel Formwork



Item no. Weight kg

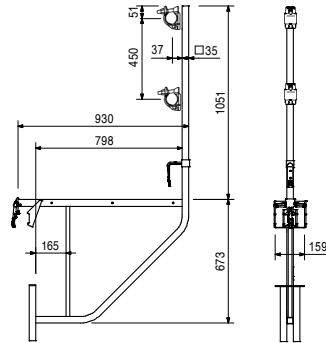
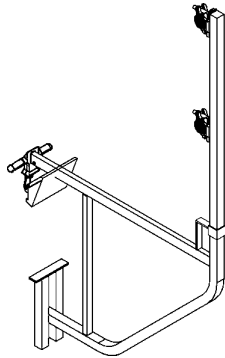
102923 12.600

Scaffold Brackets TRG Scaffold Bracket TRG 80

For assembly of a working and concreting scaffold with MAXIMO and TRIO. Mounted on horizontal and vertical struts.

Technical Data

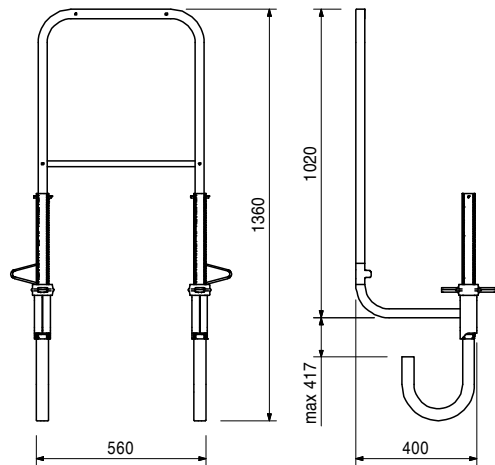
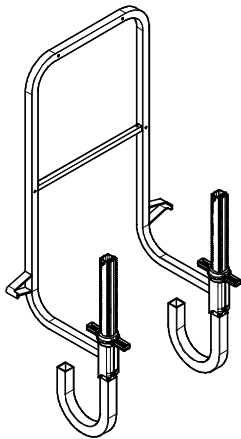
Permissible load 150 kg/m²
with maximum width of influence 1.35 m.



065066 15.100

End Guardrail Frame 55

Clampable end guardrail for all PERI Scaffold Platforms and Climbing Systems.

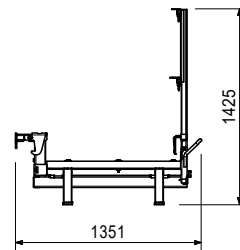
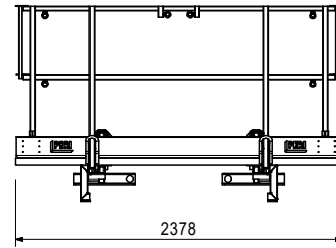
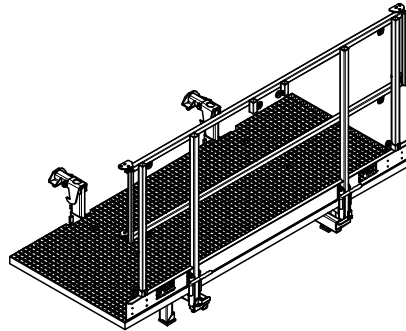


MAXIMO MX 15 Panel Formwork

Item no.	Weight kg
127273	192.000

Concreting Platform MX 100 x 240

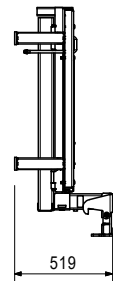
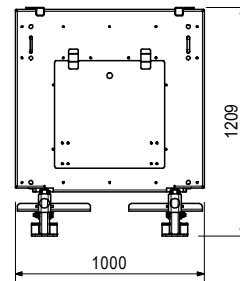
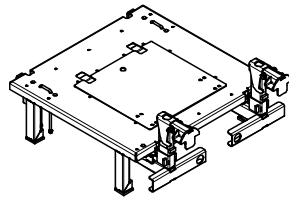
Working and concreting platform for MAXIMO and TRIO. Attached from above to the panel, selfsecuring.



127885	71.600
--------	--------

Concreting Platform Hatch MX 100 x 100

Working and concreting platform for MAXIMO and TRIO. Attached from above to the panel, selfsecuring.



115945	10.700
115946	10.700

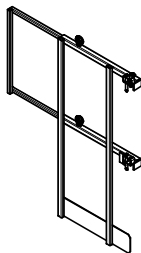
End Guardrails MXP

End Guardrail MXP left

End Guardrail MXP right

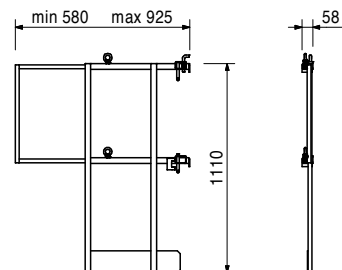
For MAXIMO Platforms MXP.

Drawing shows End Guardrail MXP left.



Complete with

2 pc. 722802 Eye Bolt M10 DIN 580, galv.



MAXIMO MX 15 Panel Formwork



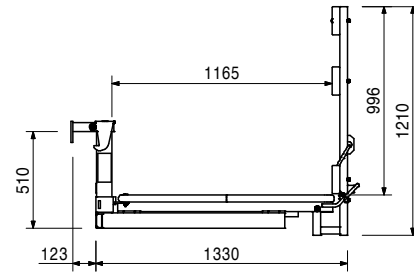
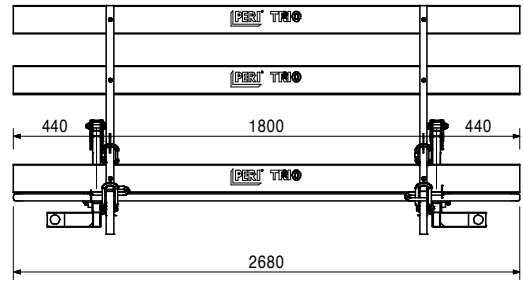
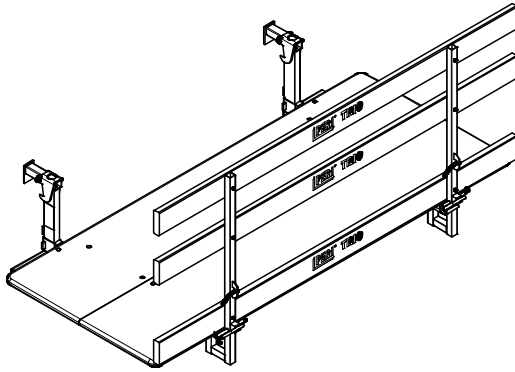
Item no.	Weight kg
022950	129.000

Concreting Platform TRIO 120 x 270

Working and concreting platform for MAXIMO and TRIO. Attached from above to the panel, self-securing.

Technical Data

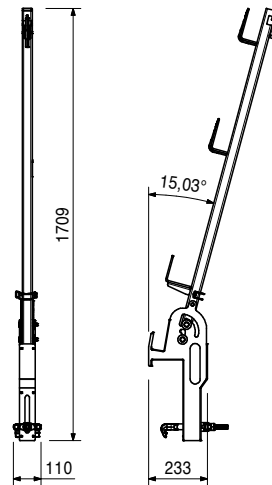
Permissible load 150 kg/m².



129960	12.100
--------	--------

Opposite Guardrail Holder MX

As guardrail for MAXIMO and TRIO.



126381	7.140
126376	9.260
126371	17.700

Side Mesh Barriers PMB

Side Mesh Barrier PMB 90

Side Mesh Barrier PMB 120

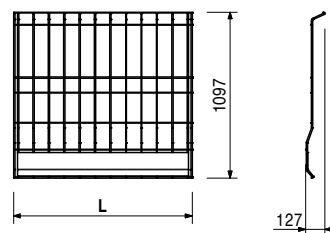
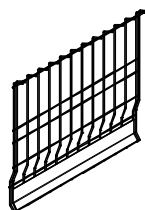
Side Mesh Barrier PMB 240

L

900

1180

2400

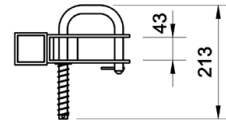
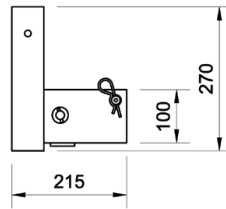
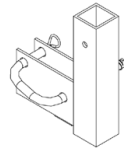


MAXIMO MX 15 Panel Formwork

Item no.	Weight kg
201592	2.810

Handrail Post Holder TRIO GB
For assembling of a guardrail to TRIO Panels.

Complete with
1 pc. 018060 Cotter Pin 4/1, galv.

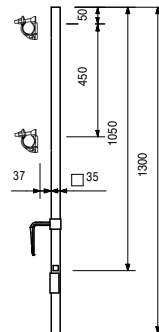


Accessories
Guardrail Post HSGP-2

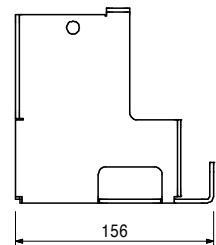
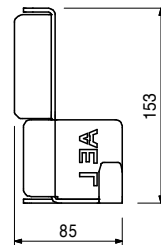
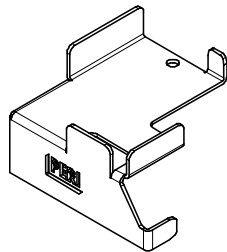
116292	4.730
--------	-------

Guardrail Post HSGP-2
As guardrail for different systems.

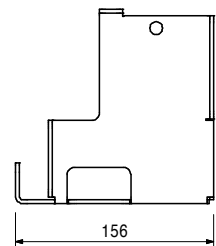
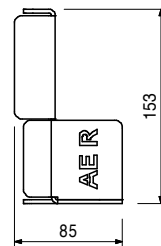
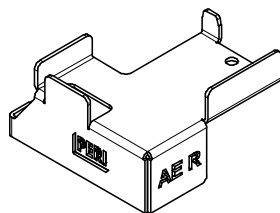
103996	4.730
--------	-------



118103 0.700 **Stacking Device L MXA**



118105 0.699 **Stacking Device R MXA**



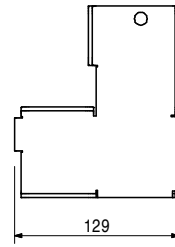
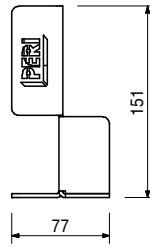
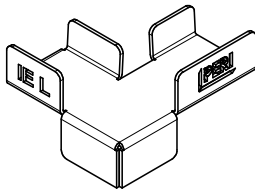
MAXIMO MX 15 Panel Formwork



Item no. Weight kg

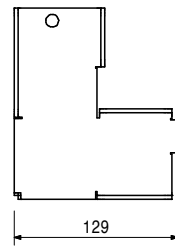
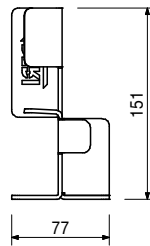
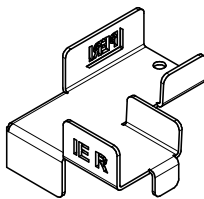
118110 0.614

Stacking Device L MXI



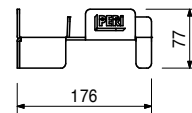
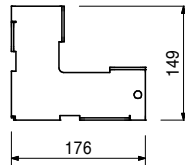
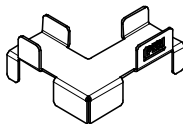
118112 0.613

Stacking Device R MXI



118100 0.652

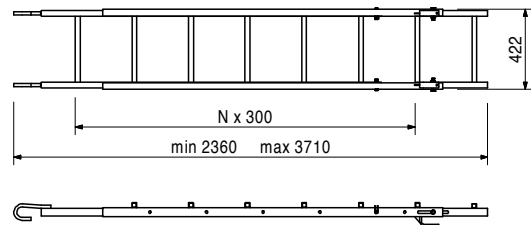
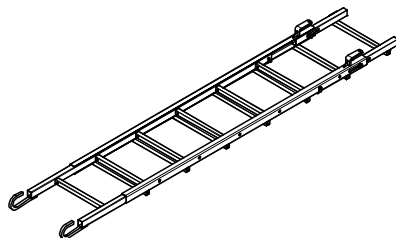
Stacking Device MX Flat for Shaft Corner MXSE



107738 24.100

Ladder 240 – 360

Adjustable from 2.40 m to 3.60 m.

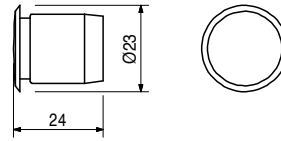
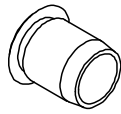


MAXIMO MX 15 Panel Formwork

Item no.	Weight kg
124895	0.002

PVC Plug MXM 15 Ø 18.3

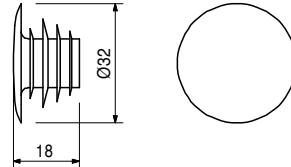
For MAXIMO Multi Panel MXM, Internal Corners 50/20 and standard panels for single faced use.



114300	0.002
--------	-------

PVC Plug MX 15 Ø 17,5 – 22

For closing MX Tie Holes in the concrete.



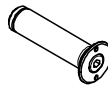
126991	0.066
126988	0.077

Stoppers MX 15

Stopper MX 15 - 75 MF-S

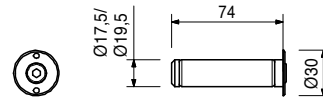
Stopper MX 15 - 75 MF-L

For closing MX Tie Holes in the concrete.



Note

For use with pressing water (waterproof concrete). Test report available!



127064	0.050
--------	-------

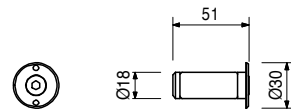
Stopper MX 15 – 50 MF-LS

For closing MX Tie Holes in the concrete.



Note

For use with non-pressing water.



127065	0.046
--------	-------

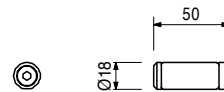
Stopper MX 15 – 50 OF-LS

For closing MX Tie Holes in the concrete if the flange should not be visible.



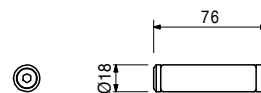
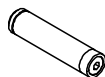
Note

For use with non-pressing water.

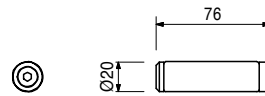
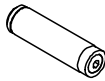


126997	0.062
--------	-------

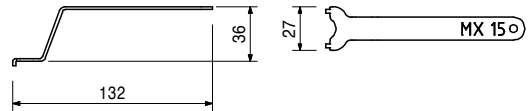
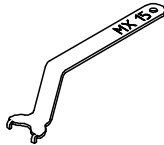
Stopper MX 15 – 75 OF-S



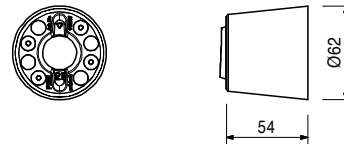
Item no.	Weight kg	
126995	0.073	Stopper MX 15 – 75 OF-L



126999	0.037	Stud Spanner MX 15-2 Packaging units contain Stoppers MX 15.
--------	-------	--

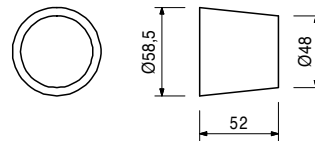
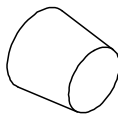


112937	0.173	Sealing Cone MX 15 For use with MAXIMO. Use with Anchor MX.	Note For use with waterproofed concrete or architectural concrete.
--------	-------	---	--



126696	1.220	Accessories Magnet Cone Spanner MX 15 / MX 18
--------	-------	---

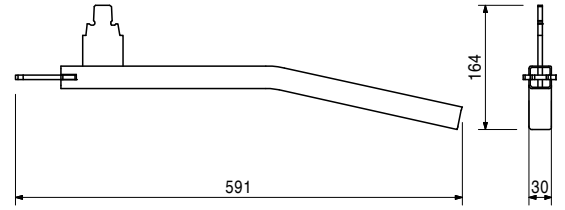
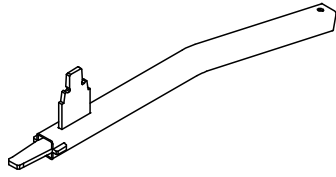
031643	0.241	DK Concrete Cone UNI 58/52 For closing anchor points with DK Sealing Cone DW 15/55, DW 20/55, DW 26/55, SK Anchor Cone DW 15, Magnet Cone MX 15 - 55, Magnet Cone MX 18 - 55, Arch. Leading Cone M24.	Note Delivery unit 50 pieces.
--------	-------	---	---



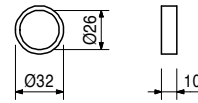
MAXIMO MX 15 Panel Formwork

Item no.	Weight kg
126696	1.220

Magnet Cone Spanner MX 15 / MX 18
 For dismantling of Magnet Cone MX 15 and MX 18.



114592	0.021	Spacer MX 15 – 10 mm
--------	-------	-----------------------------

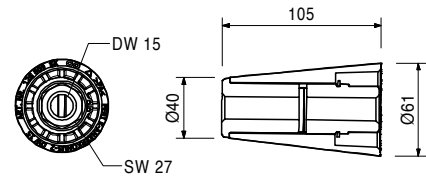
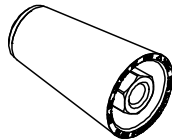


126609	0.593	SK Anchor Cone DW 15 / 2
--------	-------	---------------------------------

For waterproof, fire-resistant, soundproof and radiation-proof anchor points with Tie Rod DW 15. Suitable for vaults and strongrooms.

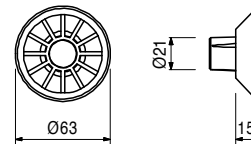
Technical Data

Permissible tension force 100 kN.
 Tie rod length = wall thickness - 2 x 55 mm



125299	0.013	Cone MX DR 22/2
--------	-------	------------------------

For the use of DW 15 Tie Rods. Fits for Spacer Tubes DR 22.

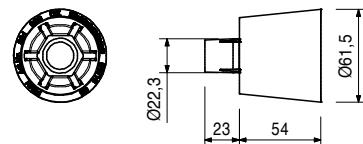
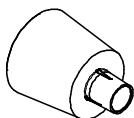


031636	0.063	DK Cone DW 15/55
--------	-------	-------------------------

For waterproof, fire-resistant and soundproof anchor points with Tie Rod DW 15. Used with Spacer Tube rough 22.

Note

Delivery unit 50 pieces.



MAXIMO MX 15 Panel Formwork



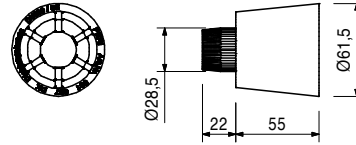
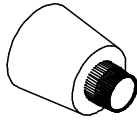
Item no.	Weight kg
031637	0.055

DK Cone DW 20/55

For waterproof, fire-resistant and soundproof anchor points with Tie Rod DW 20. Use with Spacer Tube rough 28.

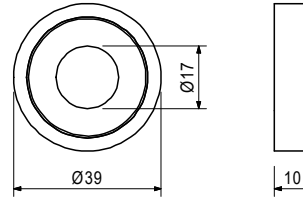
Note

Delivery unit 50 pieces.



123603	0.016
--------	-------

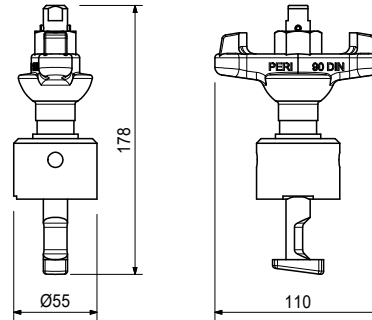
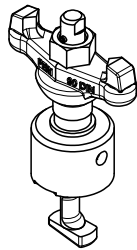
Sealing MX 15



125337	1.390
--------	-------

Extraction Tool MX Sealing

For remove of the Sealing Sleeve.



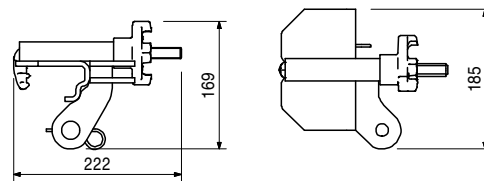
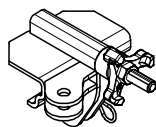
023660	3.300
--------	-------

Brace Connector TRIO, galv.

For connecting push-pull props and kicker braces to MAXIMO and TRIO Panels. Mounted on vertical and horizontal struts.

Complete with

- 1 pc. 027170 Pin Ø 16 x 42, galv.
- 1 pc. 018060 Cotter Pin 4/1, galv.



MAXIMO MX 15 Panel Formwork



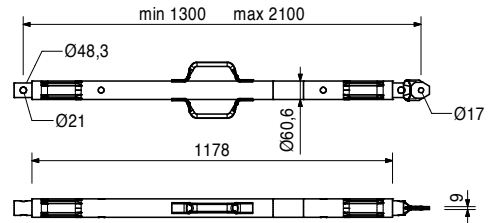
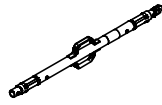
Item no.	Weight kg
117466	10.600

Push-Pull Prop RS 210, galv.

Extension length $l = 1.30 - 2.10$ m.
For aligning PERI Formwork Systems and precast concrete elements.

Note

Permissible load see PERI Design Tables.



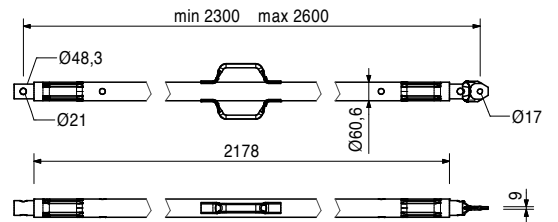
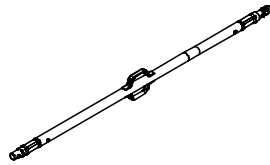
118238	12.100
--------	--------

Push-Pull Prop RS 260, galv.

Extension length $l = 2.30 - 2.60$ m.
For aligning PERI Formwork Systems and precast concrete elements.

Note

Permissible load see PERI Design Tables.



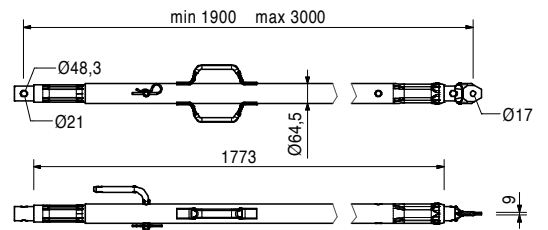
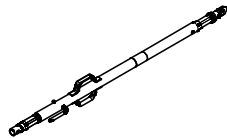
117467	15.500
--------	--------

Push-Pull Prop RS 300, galv.

Extension length $l = 1.90 - 3.00$ m.
For aligning PERI Formwork Systems and precast concrete elements.

Note

Permissible load see PERI Design Tables.



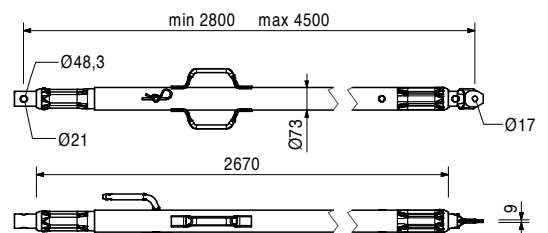
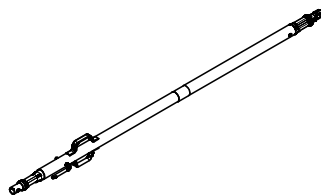
117468	23.000
--------	--------

Push-Pull Prop RS 450, galv.

Extension length $l = 2.80 - 4.50$ m.
For aligning PERI Formwork Systems and precast concrete elements.

Note

Permissible load see PERI Design Tables.



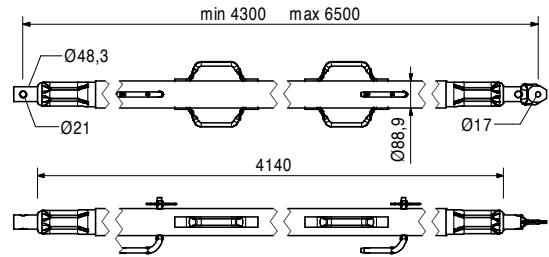
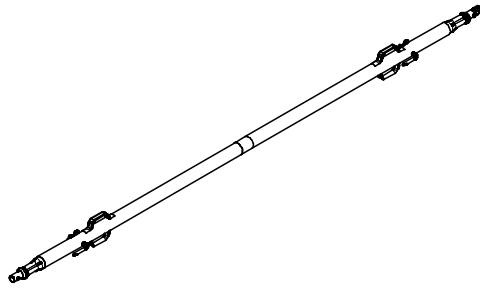
MAXIMO MX 15 Panel Formwork



Item no.	Weight kg
117469	39.900

Push-Pull Prop RS 650, galv.
 Extension length $l = 4.30 - 6.50$ m.
 For aligning PERI Formwork Systems and precast concrete elements.

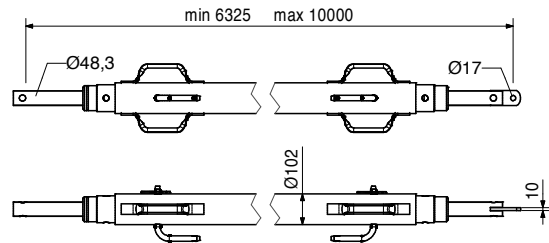
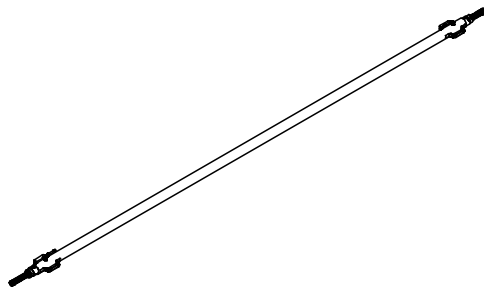
Note
 Permissible load see PERI Design Tables.



028990	115.000
--------	---------

Push-Pull Prop RS 1000, galv.
 Extension length $l = 6.40 - 10.00$ m.
 For aligning PERI Formwork Systems.

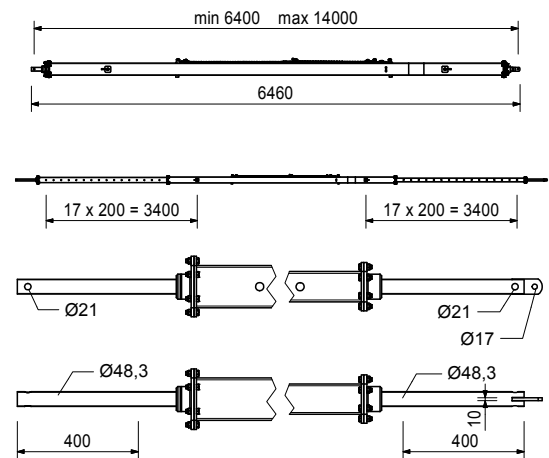
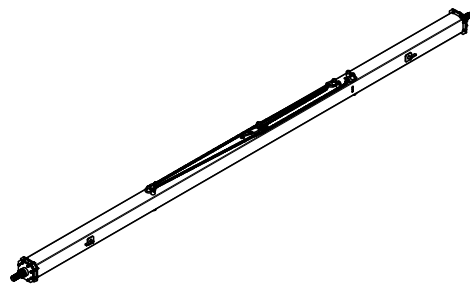
Note
 Permissible load see PERI Design Tables.



103800	271.000
--------	---------

Push-Pull Prop RS 1400, galv.
 Extension length $l = 6.40 - 14.00$ m.
 For aligning PERI Formwork Systems.

Note
 Permissible load see PERI Design Tables.
 Chain can be operated from bottom.



MAXIMO MX 15 Panel Formwork

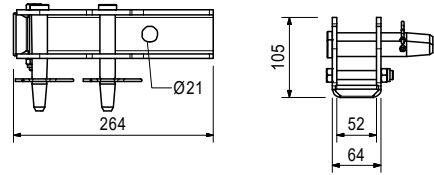
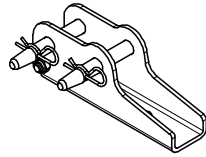
Item no.	Weight kg
126666	3.070

Base Plate-3 for RS 210 - 1400

For assembly of Push-Pull Props RS 210, 260, 300, 450, 650, 1000 and 1400.

Complete with

- 2 pc. 105400 Pin \varnothing 20 x 140, galv.
- 2 pc. 018060 Cotter Pin 4/1, galv.
- 1 pc. 113063 Bolt ISO 4014 M12 x 80-8.8, galv.
- 1 pc. 113064 Hex Nut ISO7042-M12-8-G, galv.



Accessories

124777	0.210
--------	-------

Anchor Bolt PERI 14/20 x 130

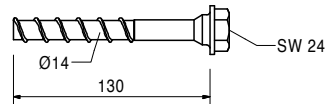
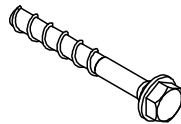
124777	0.210
--------	-------

Anchor Bolt PERI 14/20 x 130

For temporary fixation to reinforced concrete structures.

Note

See PERI Data Sheet!
Drilling \varnothing 14 mm.



**The optimal System
for every Project and
every Requirement**



Wall Formwork



Column Formwork



Slab Formwork



Climbing Systems



Bridge Formwork



Tunnel Formwork



Shoring Systems



Construction Scaffold



Facade Scaffold



Industrial Scaffold



Access



Protection Scaffold



Safety Systems



**System-Independent
Accessories**



Services



PERI Ltd
Formwork Scaffolding Engineering
 Market Harborough Road
 Clifton upon Dunsmore
 Rugby
 CV23 0AN
 +44 (0)1788 861600
 info@peri.ltd.uk
 www.peri.ltd.uk