

PERI UP Flex Heavy-Duty Prop HD

Instructions for Assembly and Use – standard configuration – Version 3.0

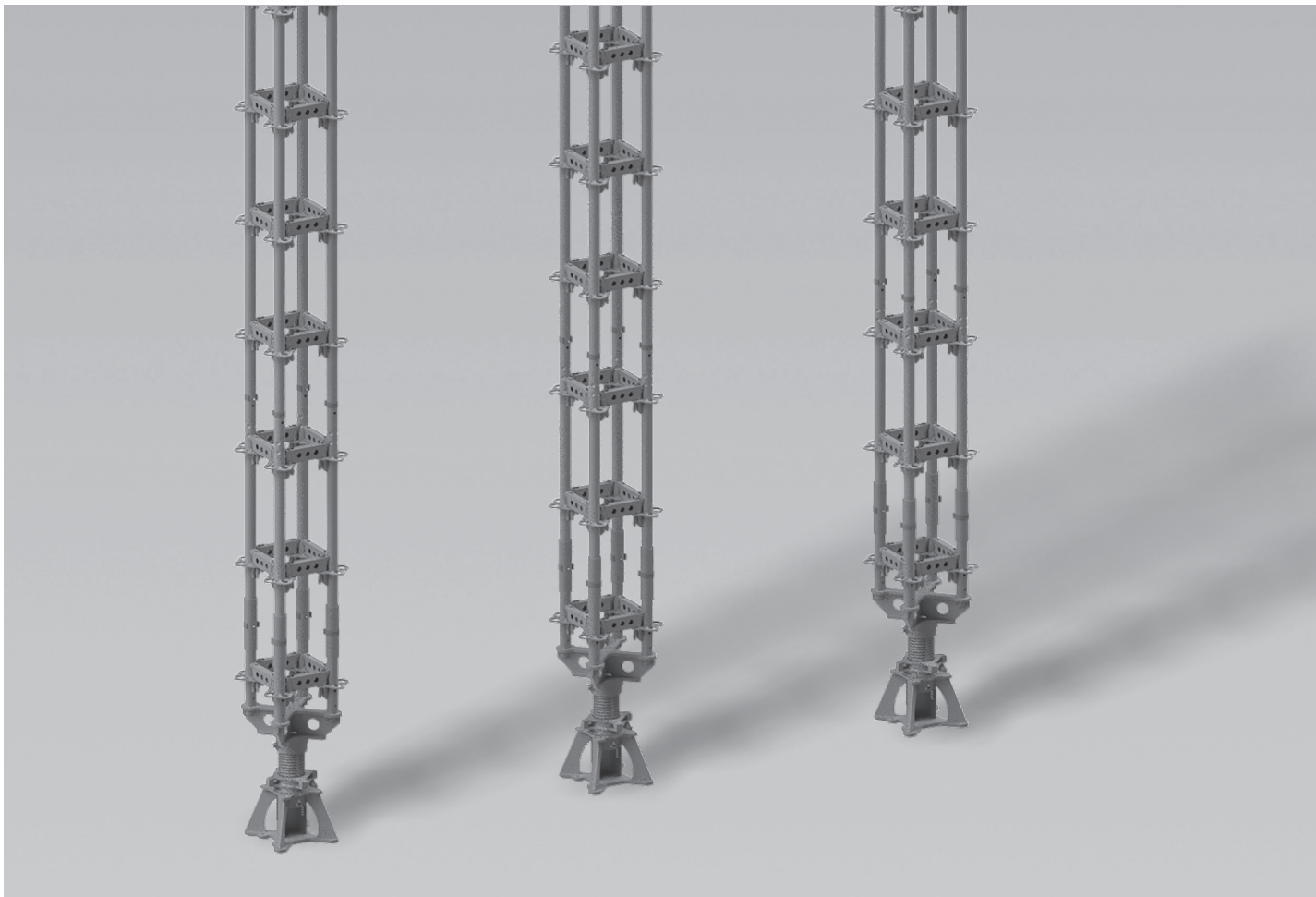

Overview

Main components	4
Key	5

Introduction

Target groups	6
Product description	7
Cleaning and maintenance instructions	8
Disposal	8
Additional technical documentation	9
Instructions for Use	9

Safety instructions

Cross-system	10
System-specific	12
Storage and transportation	12

Application

A1 Vertical assembly of individual props	14
Lowering Jack HD	14
Connection Plate UJC	15
Pre-assembly of props	16
Head Spindle TR 110-80/55	18
A2 Horizontal assembly of individual props	20
Pre-assembly of props	20
Prop erection	22
A3 Bracing individual props	24
Bracing	24
Bracing with Push-Pull Props	24
Bracing additional props using horizontal ledgers	25
A4 Dismantling individual props	26
Heavy-Duty Prop HD	26
A5 Hydraulic Lowering Unit HD	28
Load-controlled pre-loading	28
Load-controlled lowering	30
Displacement-controlled lowering	32

A6 Vertical assembly of the main beam frame	34
Overview	34
Ladder access	35
Main Beam HDT as base beam	38
Lowering Jacks	39
First Prop	40
Additional props	41
Work platform	43
Forming recesses in the decks	44
Top beam	46
Diagonal bracing	47
A7 Dismantling the main beam frame vertically	48
General information	48
Positioning free of any load	49
Lowering	50
Removing the cross girders	51
Removing the top beam	53
Removing the main beam frame	53

Variants and Tables

B1 Loads and bracing	56
Load transfer	56
Horizontal Loads	56
B2 Variants	60
Free-standing Main Beam Frames	60
Individual props without main beam	61
Main beam frames without lower	
Main Beam HDT	61
B3 Load-bearing capacities	62
B4 Materials list	64

Logistics

C1 Storage and transportation	66
-------------------------------	----

Program overview

PERI UP Flex Heavy-Duty Prop HD	68
---------------------------------	----



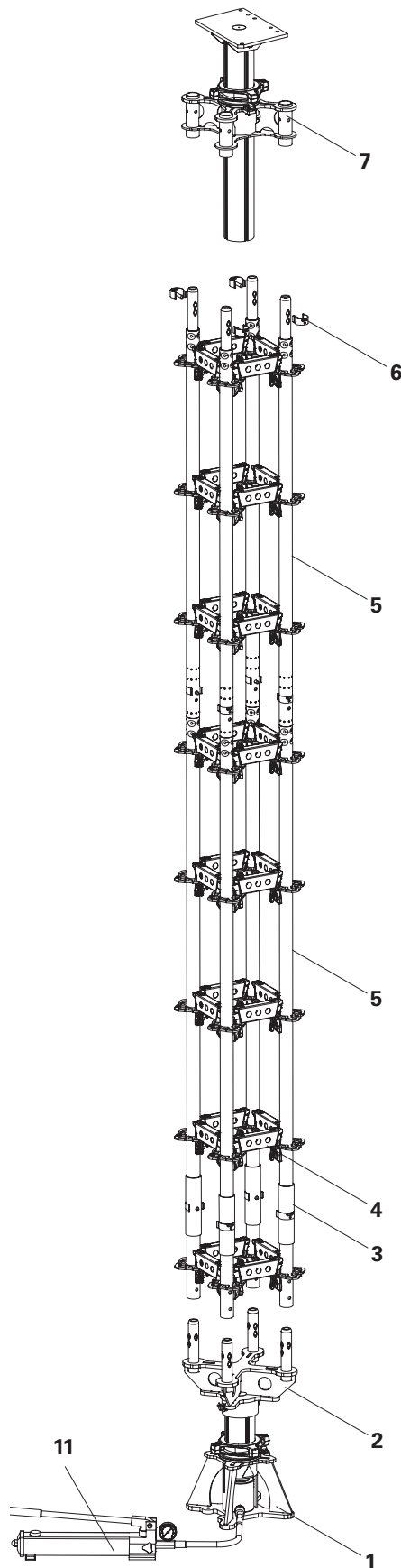









Main components





- 1 Lowering Jack HD
- 2 Connection Plate UJC
- 3 Base Standard UVB 25
- 4 Horizontal Ledger UH-2
- 5 Standard UVR-2
- 6 Locking Pin Ø 48/57 or Bolt M10 x 70, Mu
- 7 Head Spindle TR 110-80/55
- 11 Hydraulic Unit HD

Key

Pictogram | Definition

-  Danger/Warning/Caution
-  Note
-  To be complied with
-  Load-bearing point
-  Visual inspection
-  Tip
-  Incorrect use
-  Safety helmet
-  Safety shoes
-  Safety gloves
-  Safety goggles
-  Personal protective equipment to prevent falling from a height (PPE)
-  Observe additional documentation

Arrows

-  Arrow representing an action
-  Arrow representing a reaction of an action*
-  Arrow representing forces

* If not identical to the action arrow.

Safety instruction categories

The safety instructions alert site personnel to the risks involved and provide information on how to avoid these risks. Safety instructions can be found at the beginning of the section or before instructions for action and are highlighted as follows:

Danger

This sign indicates an extremely hazardous situation that could result in death or serious, irreversible injury if the safety instructions are not followed.

Warning

This sign indicates a hazardous situation that could result in death or serious irreversible injury if the safety instructions are not followed.

Caution

This sign indicates a hazardous situation that could result in minor or moderate injury if the safety instructions are not followed.

Note

This sign indicates situations in which failure to observe the information can result in material damage.

Format of the safety instructions

Signal word

Type and source of hazard!
Consequences of non-compliance.
⇒ Preventative measures.

Dimensions

Dimensions are usually given in cm. Other measurement units, e.g. m, are shown in the illustrations.

Conventions

- Instructions are numbered with: 1. ..., 2. ..., 3. ...
- The result of an instruction is shown by: →
- Position numbers are clearly provided for the individual components and are given in the drawing, e.g. **1**, in the text in brackets, for example **(1)**.
- Multiple position numbers, i.e. alternative components, are represented with a slash: e.g. **1/2**.

Notes on illustrations

The illustration on the front cover of these instructions is understood to be a system representation only. The assembly steps presented in these Instructions for Assembly and Use are shown in the form of examples with only one component size. They are valid for all component sizes contained in the standard configuration.

To facilitate understanding, detailed illustrations are sometimes incomplete. The safety equipment that might not be shown in these detailed illustrations must nevertheless be available.

Target groups

Contractors

These Instructions for Assembly and Use are designed for contractors who either

- assemble, modify and dismantle PERI systems, or
- use them, e.g. for concreting, or
- allow them to be used for other operations, e.g. carpentry or electrical work.

The contractors procedures for the control of temporary works must ensure that suitably competent persons are appointed to manage the planning and use of PERI formwork systems.

The appointed person(s):

- must identify potential hazards during the planning phase,
- determines measures that provide protection against risks,
- creates a safety and health protection plan,
- coordinates the protective measures for the contractor and site personnel so that they do not endanger each other,
- monitors compliance with the protective measures.
- must be on site for all system operations,
- prepares and updates the plan for assembly, modification and dismantling,
- prepares and updates the plan for use of the system by the user,
- supervises the assembly, modification and dismantling work (supervisor).

Competent persons qualified to carry out inspections

Due to the specialist knowledge gained from professional training, professional experience and recent professional activity, the competent person qualified to carry out inspections has a reliable understanding of safety-related issues and can carry out inspections correctly. Depending on the complexity of the inspection to be undertaken, e.g. scope of testing, type of testing or the use of certain measuring devices, a range of specialist knowledge is necessary.

Qualified personnel

PERI systems may only be assembled, modified or dismantled by personnel who are suitably qualified to do so. Qualified personnel must have completed a course of training* in the work to be performed, covering the following points at least:

- Explanation of the plan for the assembly, modification or dismantling of the system in an understandable form and language.
- Description of the measures for safely assembling, modifying or dismantling the system.
- Naming of the preventive measures to be taken to avoid the risk of persons and objects falling.

- Designation of the safety precautions in the event of changing weather conditions that could adversely affect the safety of the system, as well as the personnel concerned.
- Details regarding permissible loads.
- Description of all other risks and dangers associated with assembly, modification or dismantling operations.



- **In other countries, ensure that the relevant national guidelines and regulations in the respective current version are complied with!**

* Instructions are given by the contractor themselves or a competent person selected by them.

Product description

Regular assembly

Ground plan of the standard configuration
25 x 25 cm.

Permissible load-bearing capacities

All components listed in the program overview may be used for assembly. Other components are named, or must be planned and verified on a project-specific basis.

Features

- The height is always adjusted using the head spindle.
- The preloading and load release of the Heavy-Duty Spindle is carried out using the lowering jack with the aid of the Hydraulic Lowering Unit HD.
- The force is transmitted in a non-operating mode mechanically via the adjusting nut; the Hydraulic Lowering Unit HD is thus load-free and is removed.
- Horizontal Ledgers UH 25 Plus or UH-2 25 must be used for the Heavy-Duty Props HD.
- The Heavy-Duty Props HD in the form of shoring assemblies facilitate a wide range of project-specific applications.

Component Variants

The permissible loading tables are not valid for the use of Horizontal Ledgers UH. They require a separate static analysis.

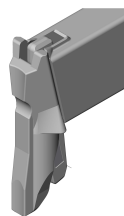

Ledger UH



Ledger UH-2
Ledger UH Plus

Ledger UH Plus may be used in substitution for Ledger UH-2.
Standards UVR may be used in substitution for UVR-2.

Technical details

- Assembly height ≤ 8.65 m.
- Permissible prop load up to 200 kN.
- Correspond to design class B1 according to DIN EN 12812.
- For leg loads, see Section B

Intended use

PERI products have been designed for exclusive use in the industrial and commercial sectors by suitably trained personnel only.

The four-legged Heavy-Duty Prop HD made of standard PERI UP System components is used for the vertical transfer of concentrated individual loads of up to 200 kN.

These occur both in shoring and in building redevelopment. The hydraulic cylinder in the base section allows displacement and force-controlled lowering of the prop under load as well as scheduled force-controlled prestressing, which is required for shoring in existing structures. However, it is not intended for lifting loads or lowering loads!

For the construction of the HD Heavy-Duty Prop, individual standards are connected with PERI UP Horizontal Ledgers UH-Plus or UH-2, which are particularly easy to assemble due to their wedge connections.

By combining standards of different lengths, all heights can be continuously achieved.

Cleaning and maintenance instructions

In order to maintain the value and operational readiness of the formwork materials over the long term, clean the panels after each use.

Some repair work may also be inevitable due to the tough working conditions.



The contractor must ensure that the personal protective equipment required for cleaning, maintenance and repair work such as

- Safety helmet,
- Safety shoes,
- Safety gloves,
- Safety goggles,

is available and used as intended.

The following instructions should help to keep cleaning and maintenance costs as low as possible.

Cleaning tools must be adapted to the respective surfaces of the components so that they are not damaged.

Mechanical components, e.g. spindles or gear mechanisms, must be cleaned of dirt or concrete residue before and after use, and then greased with a suitable lubricant.

Provide suitable support for the components during cleaning so that no unintentional change in their position is possible.

For maintenance and cleaning of the hydraulic unit, observe the Instructions for Use of the hydraulic unit.

Do not use plastic components if fibre reinforcements are exposed.

Provide suitable support for the components during cleaning so that no unintentional change in their position is possible.

Do not clean components suspended on crane lifting gear.

Components with wood parts are to be stored in well-ventilated and dry conditions.

Any repairs to PERI products are to be carried out by PERI qualified personnel only.

Disposal

Carry out disposal in accordance with the relevant national regulations.

Additional technical documentation

- Approvals
 - Approval – Z-8.22-863 PERI UP Flex Module System
 - Approval – Z-8.34-873 Girder Clamp HD
- Instructions for Use
 - Hydraulic Lowering Unit HD
- Instructions for Assembly and Use
 - Push-Pull Props RS and RSS
 - PERI UP Scaffolding Kit core components
- User information
 - Pallets and stacking devices
- Data sheet – Anchor bolt PERI 14/20 x 130
- Design tables PERI UP/Edition 2021

Instructions for Use

Use in a way not intended, deviating from the standard configuration or the intended use according to the Instructions for Assembly and Use, represents an application with a potential safety risk, e.g. risk of falling.

Deviations from the standard configuration must be verified for the application by means of separate strength and stability calculations and explicitly reflected in the assembly instructions.

All components listed in the program overview may be used for assembly. Other components are not permitted. Exceptions are named or must be planned and verified on a project-specific basis.

Additional wind attack surfaces due to icing are not taken into account. Snow and ice loads are not taken into account.

The use of other products and spare parts is not allowed.

Changes to PERI components are not permitted.

The system described in these Instructions for Assembly and Use may contain patent-protected components.

Cross-system



Safety instructions apply to all service life phases of the system.

General information

The contractor must ensure that the Instructions for Assembly and Use supplied by PERI are available at all times and understood by the site personnel.

These Instructions for Assembly and Use can be used as a basis for the site based Risk Assessment and Method Statement (RAMS) compiled by the contractor. They are not to be considered as a substitute for the RAMS.

Observe and comply with the safety instructions and permissible loads.

For the application and inspection of PERI products, observe the current laws and regulations in force in the respective countries.

Materials and working areas are to be inspected before each use and assembly for:

- damage,
- stability and
- functional correctness.

Damaged components must be exchanged immediately on site and may no longer be used.

Safety components are to be removed only when they are no longer required.

When on slab formwork, scaffolds and working platforms:

- do not jump,
- do not run,
- do not drop anything from or onto it.

Components provided by the contractor must comply with the characteristics stipulated in these Instructions for Assembly and Use and all applicable laws and standards. Unless otherwise indicated, the following applies in particular:

- Timber components:
Strength class C24 for solid wood according to EN 338.
- Scaffolding tubes:
Galvanised steel tubes with minimum dimension \varnothing 48.3 x 3.2 mm according to EN 12811-1:2003 4.2.1.2.
- Scaffolding tube couplings:
according to EN 74-1 and EN 74-2.

Deviations from the standard configuration are only permitted after a further risk assessment has been carried out by the contractor.

Appropriate measures for working and operational safety, as well as stability, are defined on the basis of this risk assessment.

Corresponding proof of stability can be provided by PERI on request if the risk assessment and resulting measures to be implemented are made available.

Nails and wood screws must not protrude. Only allow other connecting components to protrude to the extent that is necessary.

If necessary, mark protruding components or fit them with protective material.

Secure all pins with cotter pins and all bolts with nuts

Before and after exceptional occurrences that may have an adverse effect on the safety of the scaffolding system, the contractor must immediately

- produce another risk assessment and make use of its results to take suitable steps to guarantee the stability of the scaffolding system,
- arrange for an extraordinary inspection to be carried out by a competent person qualified to do so. The aim of this inspection is to identify and rectify any damage in good time in order to guarantee safe use of the scaffolding system.

Exceptional events could be:

- accidents, fire, explosions, collisions,
- long periods of non-use,
- natural events, e.g. heavy rainfall, heavy snowfall, significant icing, storms or earthquakes.

Suitable measures could be:

- removing nets/tarpaulin,
- clearing snow and ice,
- reducing live loads,
- securing loose materials.

Assembly, modification and dismantling work

PERI systems may only be assembled, modified or dismantled under the supervision of a person qualified to do so and by technically suitable employees. The qualified personnel must have received appropriate training for the work to be carried out with regard to specific risks and dangers.

On the basis of the risk assessment and Instructions for Assembly and Use, the contractor must create installation instructions, in order to guarantee safe assembly, modification and dismantling of the climbing unit.

Before initial use, the safe functioning of the scaffold must be checked by a person qualified to carry out the inspection. The results of the inspection must be documented in an inspection log.



The contractor must ensure that the personal protective equipment required for the assembly, modification or dismantling of the climbing formwork, e.g.

- Safety helmet,
- Safety shoes,
- Safety gloves,
- Safety goggles,

is available and used as intended.

For work at a higher level, use an approved ladder or platform system, or an assembly scaffold.



If personal protective equipment against falling from a height (PPE) is required or specified in local regulations, the contractor must determine appropriate attachment points on the basis of the risk assessment.

The PPE to be used to prevent falling is determined by the contractor.

The contractor must

- provide safe working areas for site personnel, which are to be reached through the provision of safe access ways. cordon off and clearly mark danger zones.
- guarantee stability during all stages of construction, in particular during assembly, modification and dismantling operations.
- ensure and demonstrate that all loads that occur are safely transferred.

Use

Every contractor who uses or allows the PERI systems to be used, is responsible for ensuring that the equipment is in good condition.

If the system is used successively or at the same time by several contractors, the health and safety coordinator must point out any possible mutual hazards and all work must then be coordinated.

When systems are used in publicly accessible areas,

- measures to prevent unauthorised use, e.g. enclosure of access areas, must be taken.
- Measures are taken against injuries caused by bumping against protruding components, e.g. assembly of protective components.

Always keep the contact surfaces of the system free of dirt, objects, snow and ice.

Close off the system in extreme weather conditions.

System-specific



Warning

Risk of confusion with other components.

Only the components specified have been structurally verified for this application.

⇒ To identify the correct components, use the assembly instructions for PERI UP Scaffolding Kit core components.

Only position Heavy-Duty Props HD free of any load if the person in charge has requested this.

The load-distributing support used, such as planking, must match the respective substrate. If multiple layers are required, planks are to be arranged crosswise.

It must be ensured that the scaffolding cannot shift in a horizontal direction, irrespective of what substrate is being used.

Couplings with bolt closures must be tightened with 50 Nm. This corresponds to a force of 20 kg using a lever arm length of 25 cm.

Secure all wedges with a jarring blow using a 500 g hammer.

Storage and transportation

General information

- Store and transport components in such a way that no unintentional change in their position is possible. Detach load lifting accessories and lifting gear from the lowered components only if they are in a stable position and no unintentional change is possible.
- Do not drop the components.
- Only ever use approved and inspected means of transportation from PERI incl. lashing, lifting gear and slings.
- Only attach the means of transport to the intended attachment points using suitable lifting gear and slings.

During the relocation procedure

- ensure that components are picked up and set down in such a way that unintentional falling over, falling apart, sliding, falling down or rolling is avoided.
- always use ropes to guide components or assemblies that are susceptible to wind when moving them with a crane.
- no one is allowed to remain under the suspended load.
- The access areas on the construction site must be free of obstacles and tripping hazards, and must also be slip-resistant.
- For transportation, the substrate must have sufficient load-bearing capacity.
- Use original PERI storage and transport systems, e.g. Crate Pallets, pallets or stacking devices.

Lowering Jack HD



Warning

Mechanically moving components. During operations, there is a risk of pinching and crushing hands and feet.
 ⇒ Wear safety shoes and safety gloves and do not grasp or reach into the cylinder in the lowering jack during operations. Keep feet away from the lowering jack.

Permissible load-bearing capacity up to 200 kN.

Components

- 1 Lowering Jack HD



- The height of the prop is adjusted exclusively via the adjusting nut on the head spindle.
- Slot 9 is recommended as a basic setting if component activation is carried out later.
Use slot 3 if component pretensioning is required.
- Set up the lowering jack on a level and sufficiently load-bearing substrate, e.g. for load distribution: steel plate 350 x 350 x 15 mm on concrete of grade C 12/15.

Preparation

Unscrew the spindle tube (1.1) until the red pressure piece is visible in the "Slot 9".

(Fig. A1.01 + A1.01a)

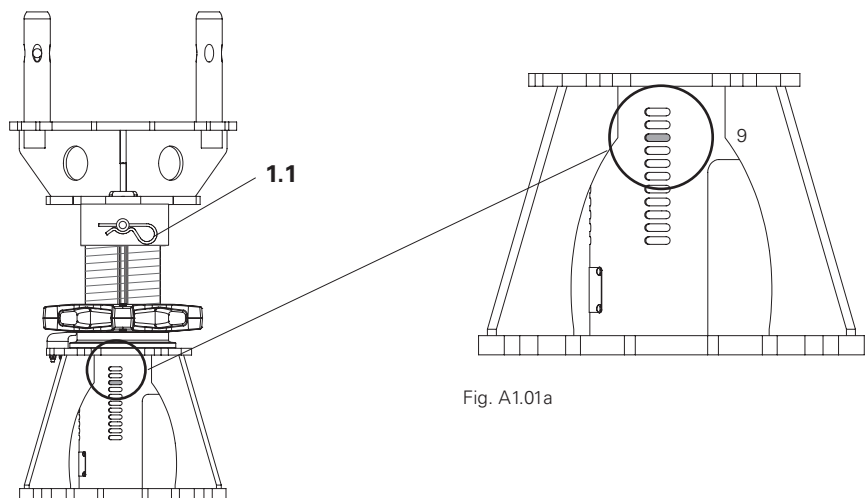

Fig. A1.01

Fig. A1.01a

Connection Plate UJC

Components

- 2** Connection Plate UJC



- The connecting bolt secures the inner spherical piece.
- The system height (H_S) of the Lowering Jack HD and Connection Plate UJC is adjustable from 45.5 to 56.5 cm. The height when using the basic setting "slot 9" is 54.5 cm.

Assembly

1. Place the connection plate (**2**) with connecting bolt (**2.2**) on the spindle tube. (Fig. A1.02a)
2. Loosen the cotter pin and remove the plate.
3. Remove the connecting bolt (**2.2**). Connection plate slides down and spherical piece (**2.1**) is positioned on the spindle tube. (Fig. A1.02b)
4. Insert connecting bolts into the connection plate.
5. Fit the plate and secure it with a cotter pin. (Fig. A1.02c)

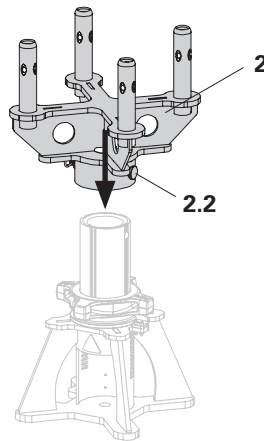

Fig. A1.02a

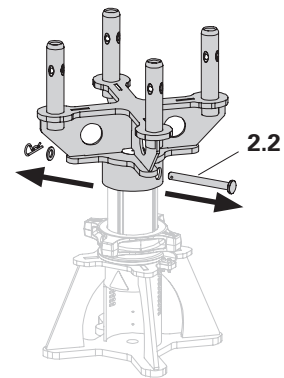

Fig. A1.02b

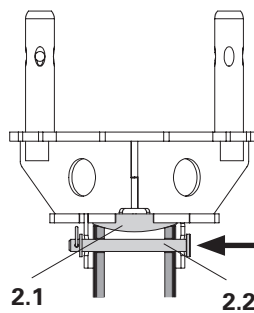

Fig. A1.02c

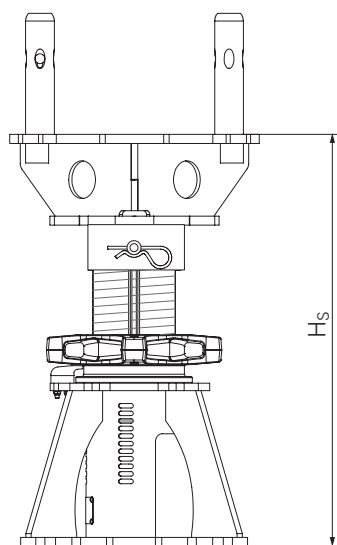

Fig. A1.02d

Pre-assembly of props



Warning

Risk of confusion with other components.

Only the components specified have been structurally verified for this application.

⇒ To identify the correct components, use the assembly instructions for PERI UP Scaffolding Kit core components.

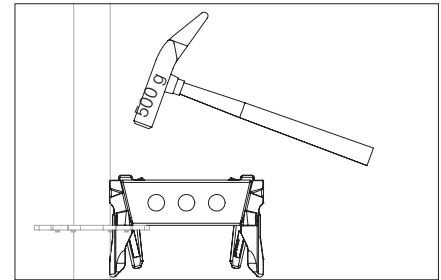
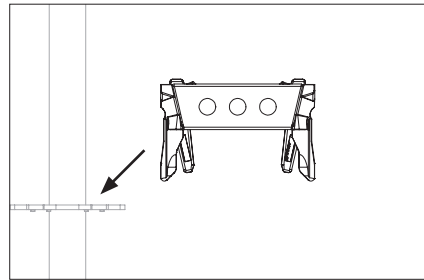

Components

- 3 Base Standard UVB 25
- 4 Horizontal Ledger UH-2 25
- 5 Standard UVR-2
- 6 Locking pin Ø 48/57
Bolt M10 x 70, Mu (alternatively)



- For props with a structure height $h > 6$ m, the Standard UVR-2 300 must be installed centrally in the leg arrangement.
- When assembling, keep the symmetrical arrangement of the standard joints, see Section "B4 Materials list" on page 64.
- The prop can be pre-assembled in units or full length, e.g. from a working scaffold.
- The prop can be tilted up to 2° via the connection plate.
- Align all the holes of the standards in one direction.
- Spacing of horizontal ledgers one above the other: 50 cm.

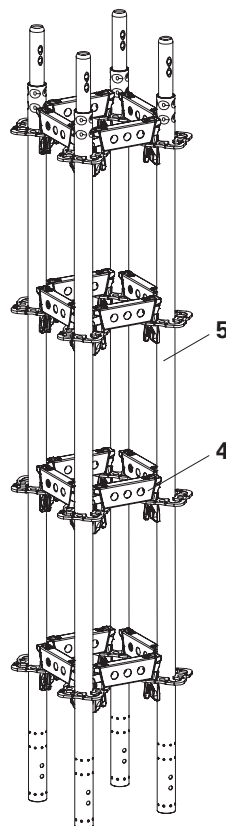

Fig. A1.03

Assembly

1. Assemble Standards UVR-2 (5) and Horizontal Ledgers UH-2 25 (4) to the required height to form a prop or unit. Use a 500 g hammer to secure all wedges with a jarring blow (Fig. A1.03).

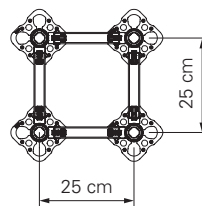

Fig. A1.03a

A1 Vertical assembly of individual props

2. Push the Base Standards UVB-25 (3) onto the pins of the Connection Plate UJC (2) (Fig. A1.04a + A1.04b).
3. Connect Base Standards UVB (3) to Horizontal Ledgers UH-2 25 (4). Secure the wedges. (Fig. A1.04b)
4. Insert pre-assembled standard arrangement, see Section "B4 Materials list" on page 64, into Base Standards UVB and secure with locking pins. (Fig. A1.05)
5. Secure the prop against tipping, see Section "A3 Bracing individual props" on page 24.

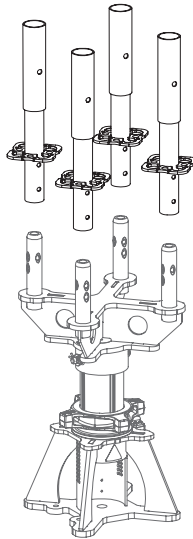

Fig. A1.04a

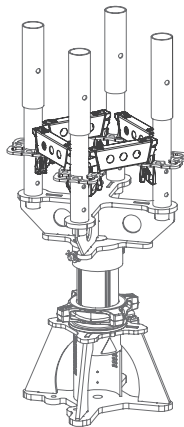

Fig. A1.04b

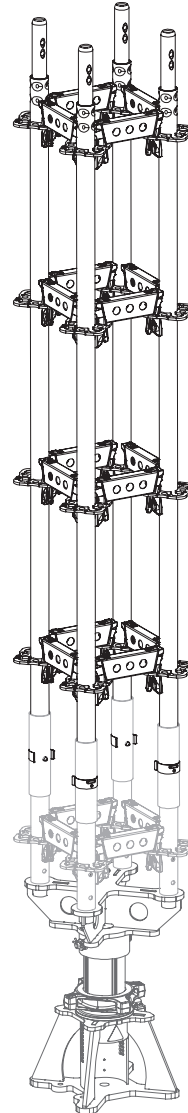

Fig. A1.05

Head Spindle TR 110-80/55

Components

7	Head Spindle TR 110-80/55	1x
6	Locking Pin \varnothing 48/57	4x



- The height of the prop is adjusted exclusively via the adjusting nut on the head spindle.
- The system height (H_s) of the Head Spindle TR is adjustable from 28.6 to 83.6 cm.
- Usable spindle length 55 cm.
- The head spindle can be tilted uniaxially up to 3° .
- Assembly is carried out in a safe working area, e.g. working scaffold.

Assembly

1. Fit the head spindle (**7**) onto the pins of the Standards UVR-2.
2. Tightly connect the Standards UVR-2 and the head spindle with locking pins \varnothing 48/57 (**6**). (Fig. A1.06)
Alternatively: Use bolt M10 x 70 with nut.

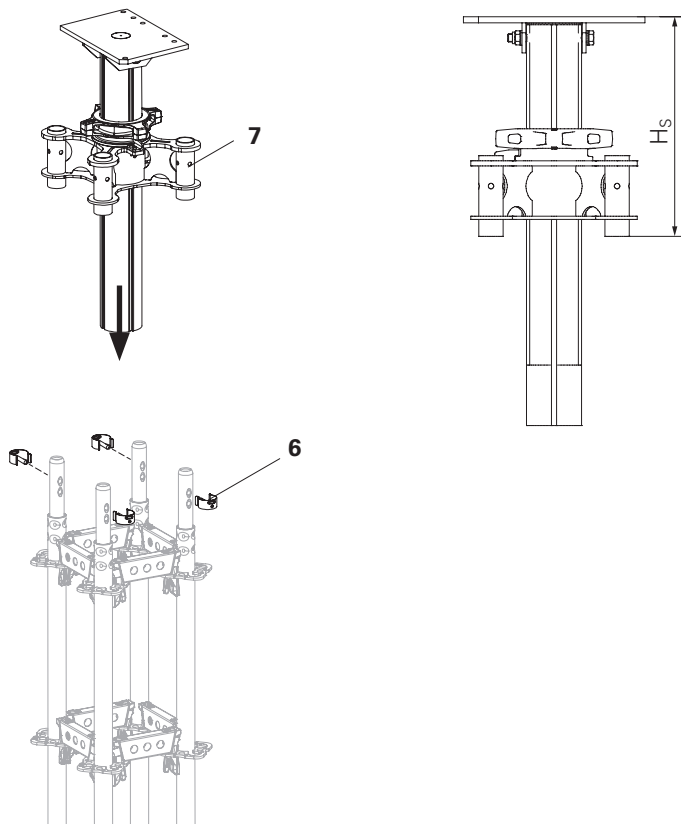

Fig. A1.06



Building redevelopment

If there is not enough free space to mount the head spindle from above during vertical assembly, the head spindle can be mounted from the side.

Assembly

1. Remove the horizontal ledger (4) up to the joint of the standard on three sides of the prop.
2. Remove the $\varnothing 48/57$ locking pins (6) from two adjacent standards.
3. Turn both free Standards UVR-2 by 45°. (Fig. A1.07a)
 - Head spindle (not spindled out) can be installed from the side.
4. Push the spindle tube (7.1) between the rosettes of the turned standards and put the head spindle on the standards. (Fig. A1.07)
5. Turn back the standards.
6. Connect the standard joints and the head spindle with locking pins so that they are tension-proof.
7. Install the remaining horizontal ledgers.

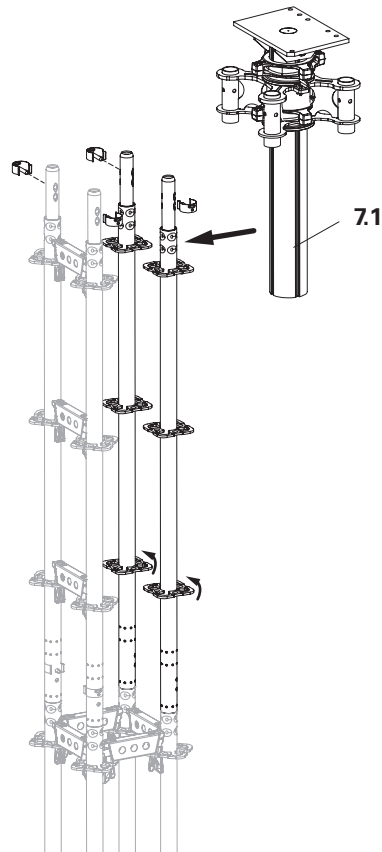

Fig. A1.07

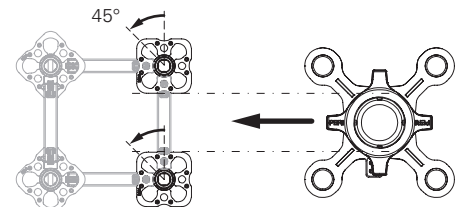

Fig. A1.07a

Pre-assembly of props

The prop can be pre-assembled in units or full length.

Components

-
- 2** Connection Plate HD
 - 3** Base Standard UVB 25
 - 4** Horizontal Ledger UH-2 25
 - 5** Standard UVR-2
 - 6** Locking pin \varnothing 48/57
Bolt M10 x 70, Mu (alternatively)
 - 7** Head Spindle TR 110-80/55
-



- For props with a structure height $h > 6$ m, the Standard UVR-2 300 must be installed centrally in the leg arrangement.
- When assembling, keep the symmetrical arrangement of the standard joints. Align all the holes of the standards in one direction.
- Spacing of horizontal ledgers one above the other: 50 cm.
- Use a 500 g hammer to secure all wedges with a jarring blow.

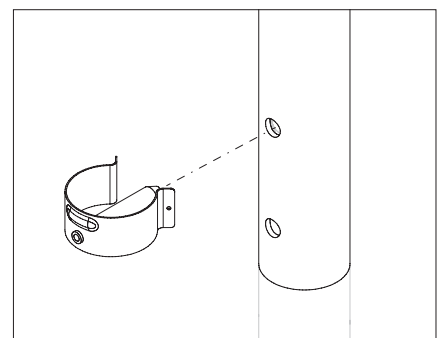
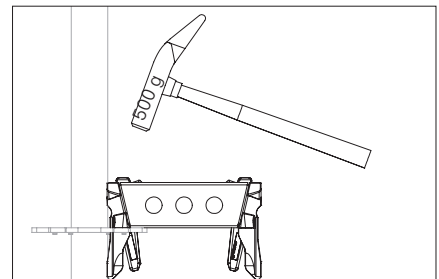
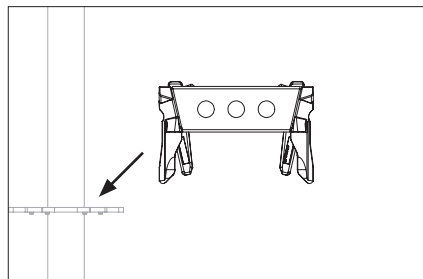

A2 Horizontal assembly of individual props

Assembly

1. Assemble Standards UVR-2 (5) and Horizontal Ledgers UH-2 (4) to form a prop up to the required height.
2. Place the Base Standards UVB-25 (3) on the standards and connect them with the locking pins (6). (Fig. A2.01)
3. Connect Base Standards UVB (3) to Horizontal Ledgers UH-2 25 (4). Secure the wedges. (Fig. A2.02)
4. Fit the Head Spindle TR 110-80/55 (7) onto the pins of the standards and tightly connect using the locking pins (6). (Fig. A2.03)

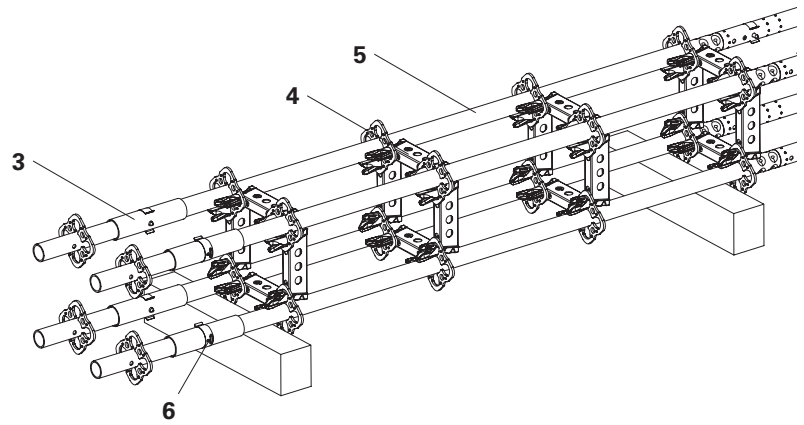

Fig. A2.01

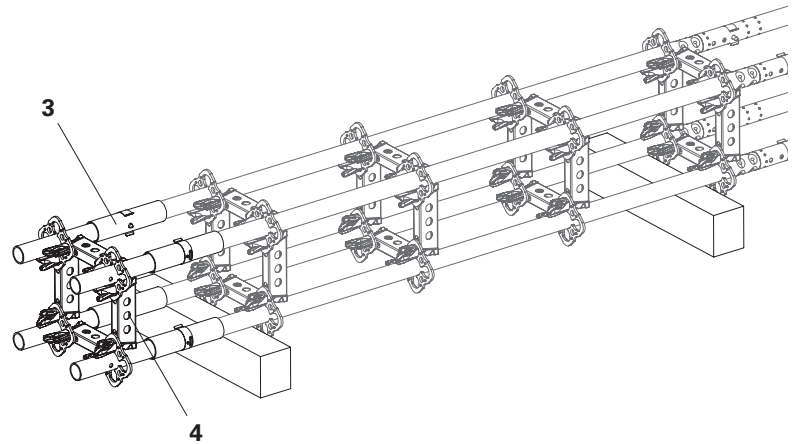

Fig. A2.02

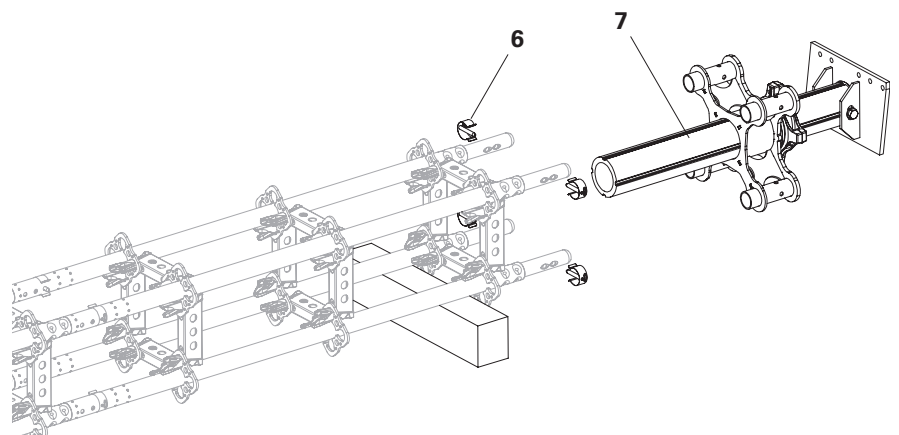

Fig. A2.03

Prop erection

Components

-
- 1 Lowering Jack HD
 - 2 Connection Plate UJC
-



- The height of the prop is adjusted via the adjusting nut on the head spindle.
- Set up the lowering jack on a level and sufficiently load-bearing substrate, e.g. for load distribution: steel plate 350 x 350 x 15 mm on concrete of grade C 12/15.



Are all connections tight?
Are all horizontal ledgers secured in position?

Preparation

- Unscrew the spindle tube (1.1) until the red pressure piece is visible in the "Slot 9". (Fig. A2.04a)

Erection

1. Attach the Heavy-Duty Prop HD around the standard supports (7.2) of the head plate with a textile sling and carefully lift the prop. (Fig. A2.04)

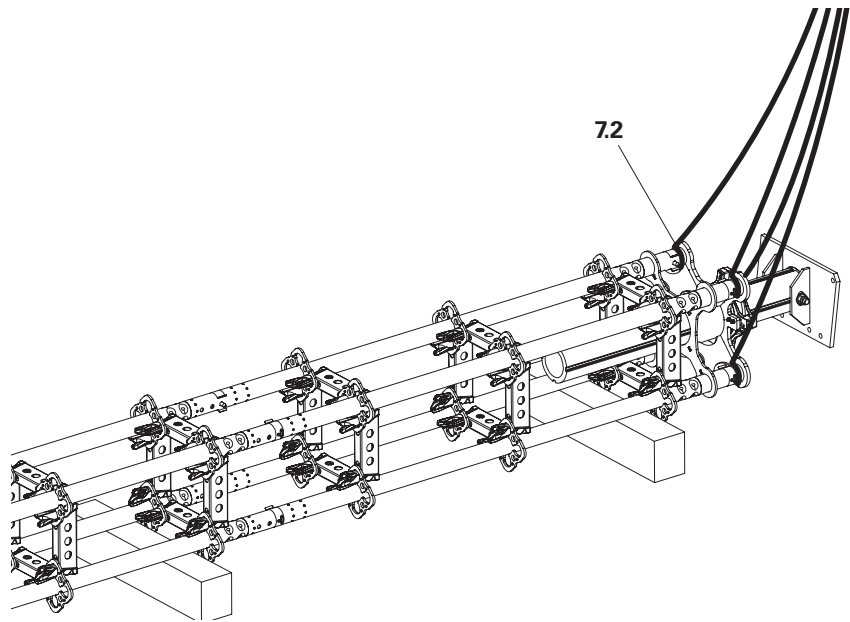

Fig. A2.04

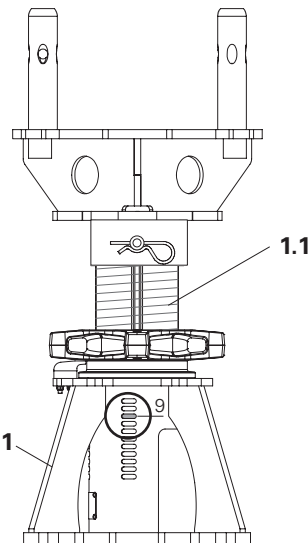

Fig. A2.04a

2. Place the standard set with base standards on the connection plate (2) and lower it. (Fig. A2.05)
4. Secure the prop against tipping, see Section "A3 Bracing individual props" on page 24
5. Release the prop from the crane.

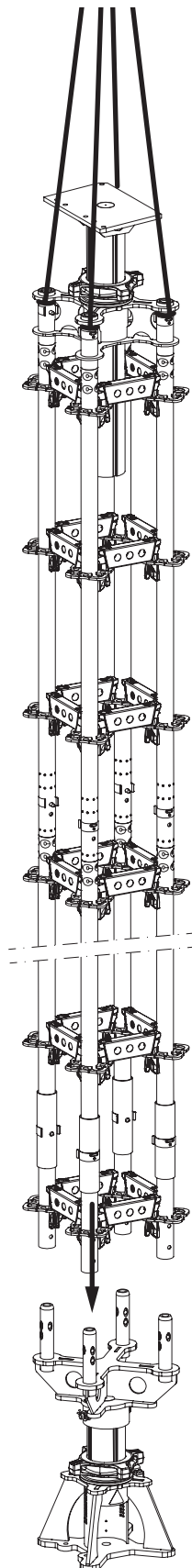

Fig. A2.05

Bracing



During assembly or disassembly, the Heavy-Duty Props HD are held in a secure position with a crane until temporary assembly aids are fitted to prevent tipping.

For longer Heavy-Duty Props HD, additional support holders are required at higher positions.

Bracing with Push-Pull Props

Components

12 Push-pull prop	3x
13 Brace Connector HDR-2	3x
14 Base Plate-2 for RS	3x
15 Tie Bolt 14/20 x 130	3x



Mount 3 push-pull props as assembly aids to ensure stability!

Assembly

1. Connect the half-coupler of the Brace Connector HDR-2 (**13**) to the Standard UVR-2.
(Fig. A3.01)
2. Fasten push-pull prop (**12**) with bolt and cotter pin.
(Fig. A3.01a)
3. Fasten the base plate (**10**) to the foundation with the tie bolt (**11**).
(Fig. A3.01b)
4. Fix push-pull prop to the base plate with bolts and cotter pins.
(Fig. A3.01b)
5. Detach the Heavy-Duty Prop HD from the crane.
(Fig. A3.01)

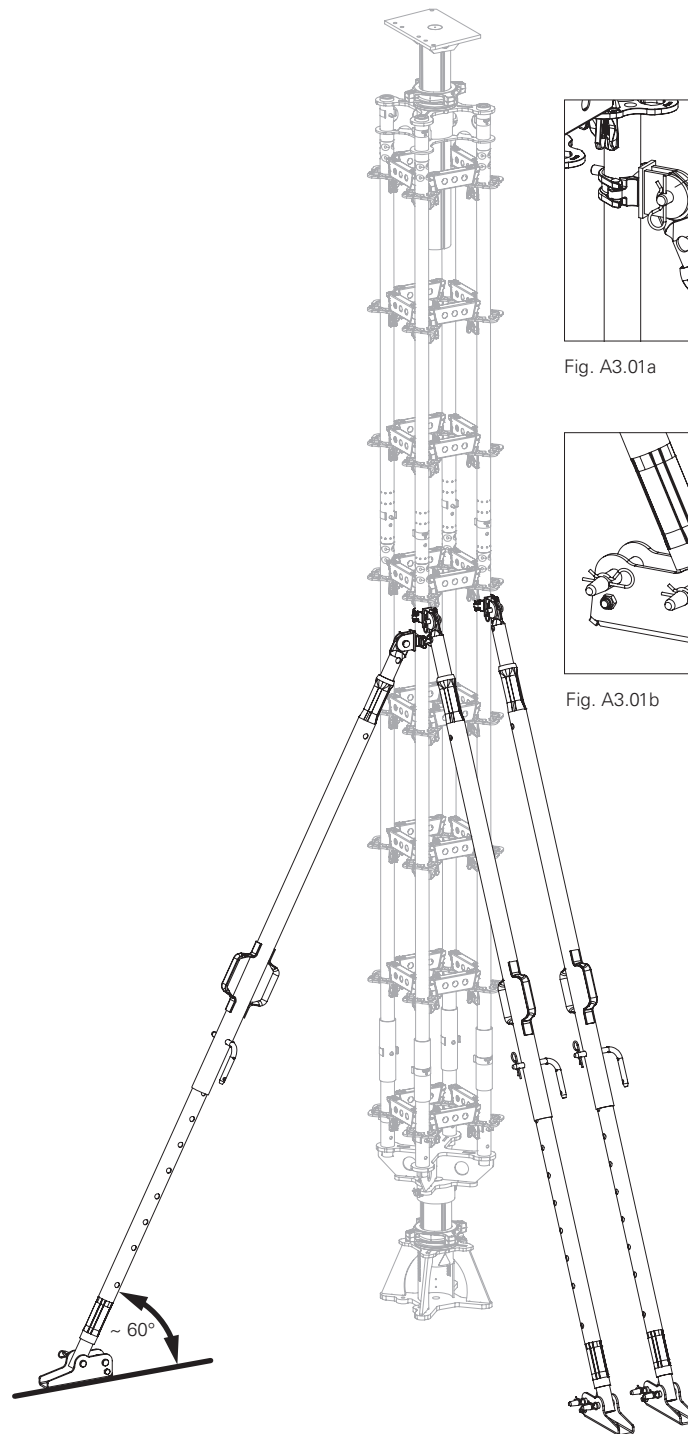

Fig. A3.01

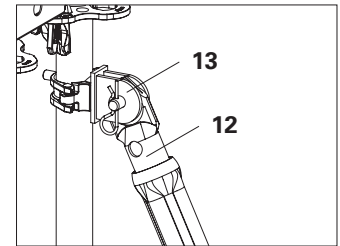

Fig. A3.01a

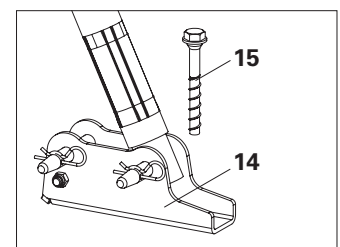

Fig. A3.01b

Bracing additional props using horizontal ledgers

Components

16 Horizontal Ledger UH-2	2x
---------------------------	----



Install push-pull props and horizontal ledgers for stability!

Assembly

1. Fit push-pull props.
2. Attach the horizontal ledger (16) to the rosettes and secure with a hammer blow.
(Fig. A3.02)



Alternatively, the props can also be secured to existing structural parts, e.g. walls, in the assembly state to prevent them from falling over or shifting horizontally.

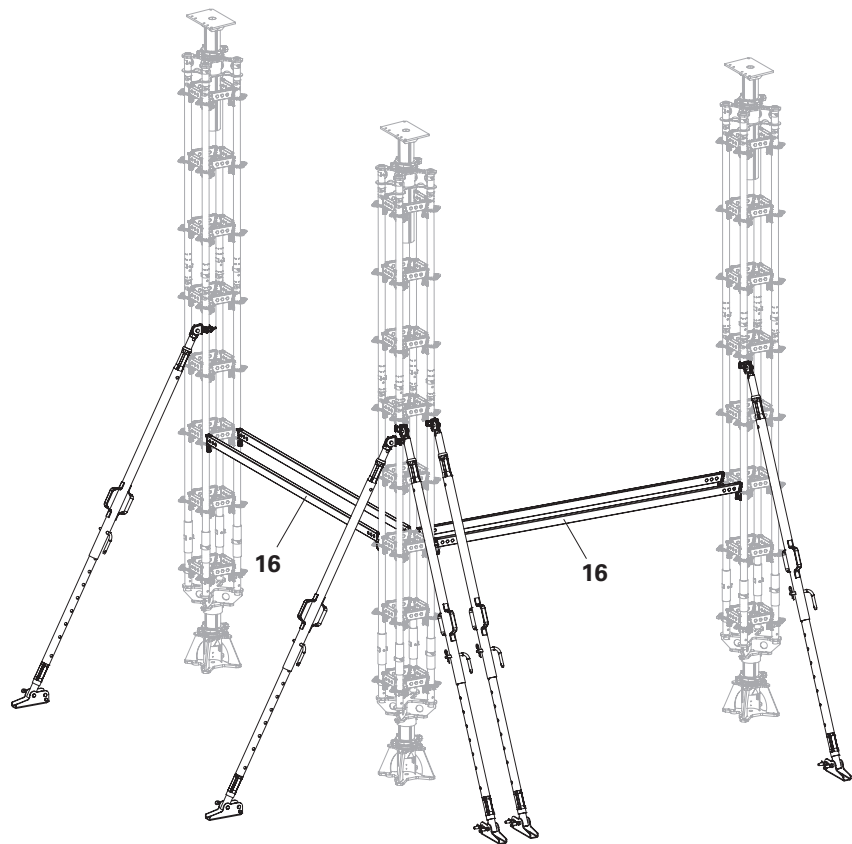

Fig. A3.02

Heavy-Duty Prop HD



Warning

Individual props may fall over during moving procedures, strike people and seriously injure them.

- ⇒ Never move individual props horizontally!
- ⇒ If individual props are dismantled when in a vertical position, secure them against falling over.

Dismantling

The prop can be dismantled when in a vertical or horizontal position.

Horizontal dismantling:

1. Attach the prop to the crane lifting gear.
2. Remove the push-pull props (**12**).
3. Lift out the prop with a crane and lay it on squared timbers.
4. Remove the Brace Connectors HDR (**13**)
5. Remove the locking pin (**6**) from the Head Spindle TR (**7**) and remove the head spindle.
6. Release the horizontal ledger (**4**) with a hammer and remove it.
7. Remove locking pins (**6a**) on standards and dismantle the standards (**5**).
8. Place the components in transport containers in an orderly manner.

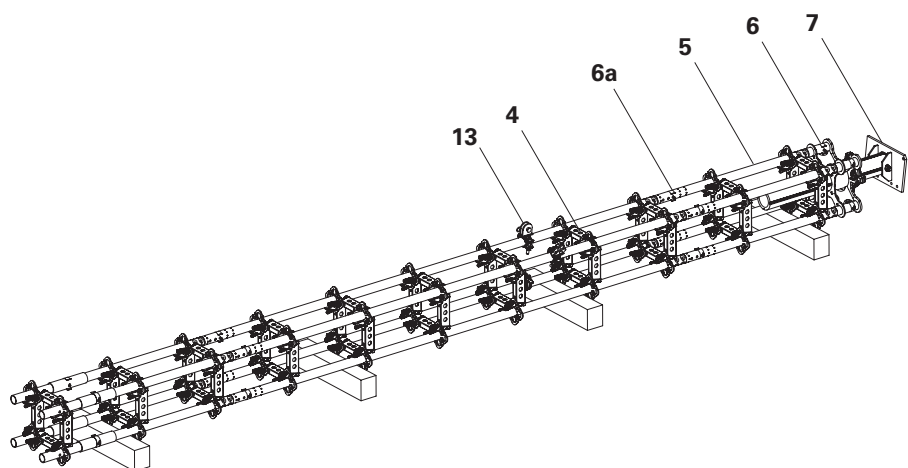

Fig. A4.01

Vertical dismantling:

Dismantling is carried out from top to bottom in a secure working area, e.g. from a working scaffold.



If there is not enough free space to remove the head spindle from above during vertical disassembly, the head spindle can be removed from the side.

Removing the head spindle

1. Lower the head spindle (7).
2. Remove the horizontal ledger (4) up to the joint of the standard on three sides of the prop.
3. Remove the $\varnothing 48/57$ locking pins (6) from two adjacent standards.
4. Turn both free Standards UVR-2 by 45° .
→ The head spindle can be removed from the side.
5. Lift the head spindle and remove the spindle tube (7.1) from the side between the rosettes of the turned standards.
6. Remove other horizontal ledgers, locking pins and Standards UVR.

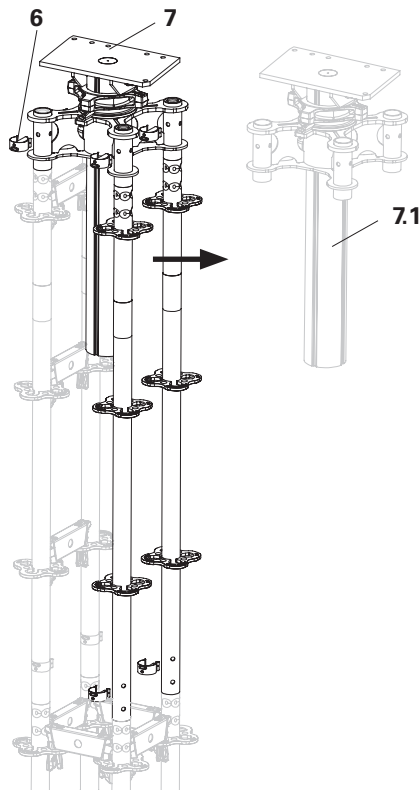

Fig. A4.01a

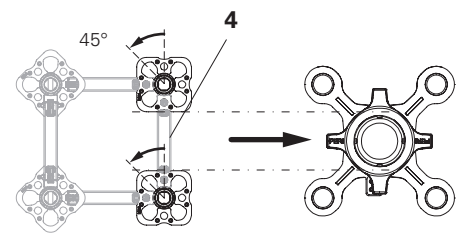

Fig. A4.01b

Connection Plate HD

1. Remove the connection plate (2) from the spindle tube. (Fig. A4.02a)
2. Remove the spherical piece (2.1).
3. Turn the connection plate over and insert the spherical piece.
4. Secure connecting bolts (2.2) with plate and cotter pins. (Fig. A4.02b)

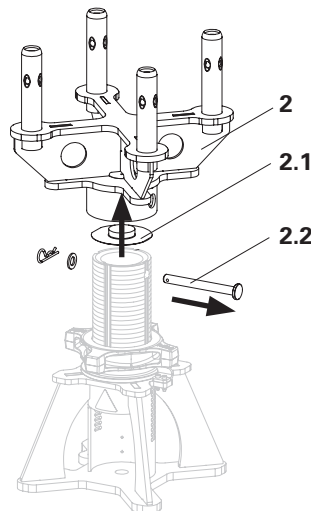

Fig. A4.02a

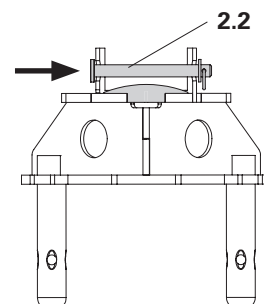

Fig. A4.02b

Load-controlled pre-loading



- Follow the Instructions for Use for the Hydraulic Lowering Unit HD!
- Permissible load-bearing capacity of up to 200 kN!
- Follow the prestressing plan!
- Remove assembly aids!
- Pre-tension groups of heavy-duty props evenly in small steps.
 - Monitor the load distribution on the manometer.
 - The cylinder stroke is limited to max. 10 mm by the adjusting nut and hold-down device.
- Illustrations are without the connection plate and Heavy-Duty Prop HD.

Requirement

- Prop or main beam frame with lowering jack is perpendicular beneath the component to be supported and the red pressure piece is visible in slot 3.
- The pump (11.1) is connected to the hydraulic cylinder (11.2). The cylinder is retracted.
- The pump valve (11.3) is closed. (Fig. A5.01 + A5.02)

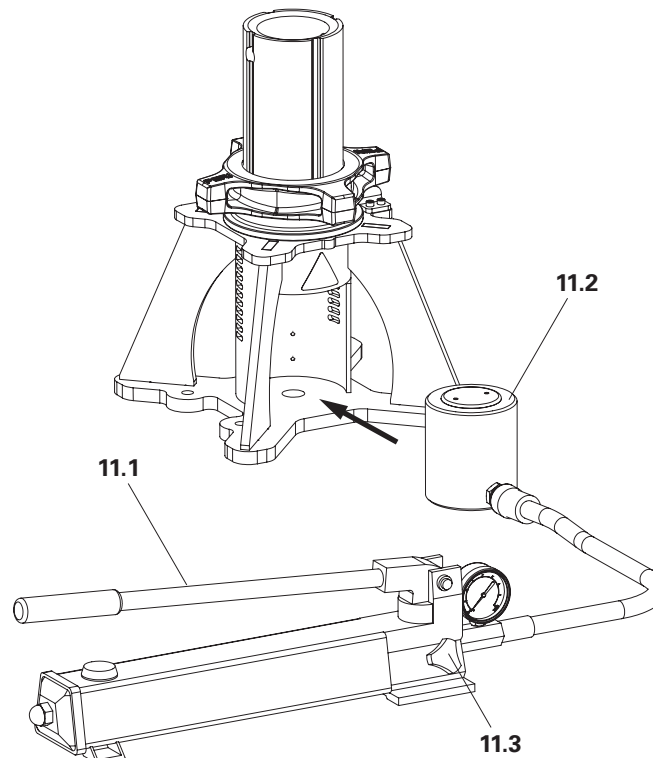

Fig. A5.01

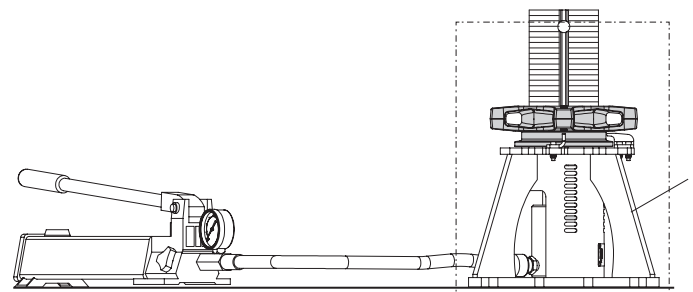
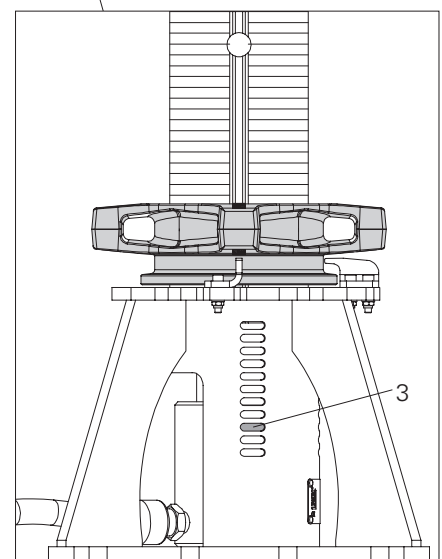

Fig. A5.02



Prestressing the prop

1. Insert the hydraulic cylinder (11.2) into lowering jack (1).
2. Operate the pump lever until the cylinder is resting on the red pressure piece (1.1) of the spindle tube. (Fig. A5.03 - A5.03b)
3. Build up pressure with the pump lever until the specified force is displayed on the manometer or the spindle is resting on the hold-down device, see static and pre-stressing plan. Monitor the free travel at the hold-down device (1.3) and the pressure on the manometer. (Fig. A5.03)
4. Rotate the adjusting nut (1.2) downwards in a clockwise direction by hand until it is resting on the plate. (Fig. A5.04)
5. Repeat steps 3 and 4 until the required force is reached.
6. Open the pump valve (11.3).
→ The hydraulic cylinder retracts and the load is transferred via the adjusting nut.

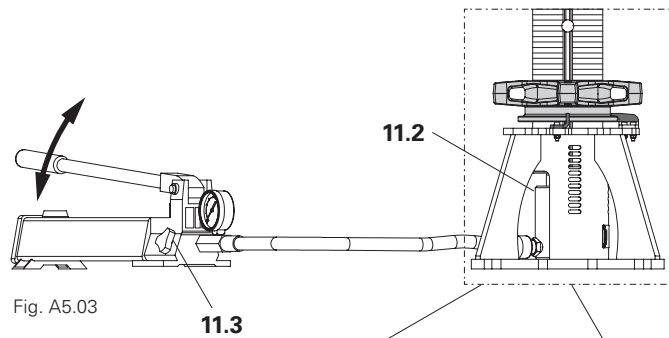

Fig. A5.03

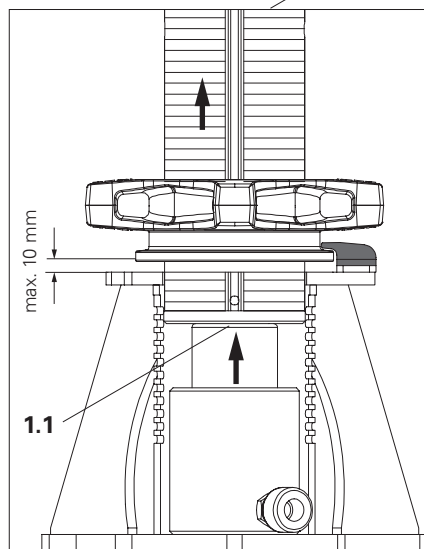

Fig. A5.03a

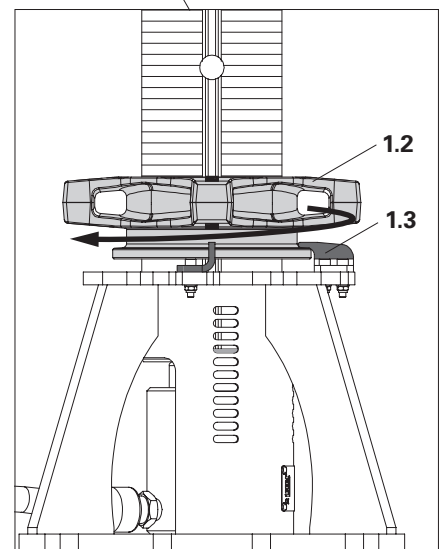

Fig. A5.03b

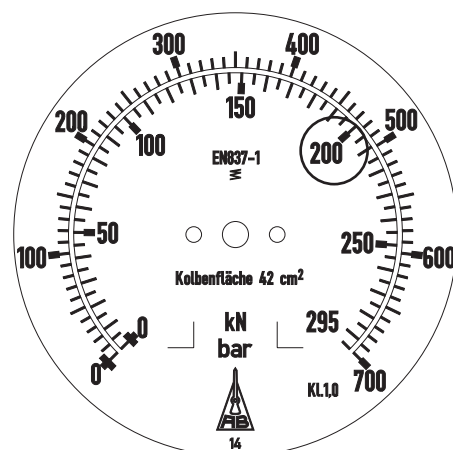

Fig. A5.04

Load-controlled lowering



- Follow the Instructions for Use for the Hydraulic Lowering Unit HD!
- Permissible load-bearing capacity of up to 200 kN!
- Follow the lowering plan!
- Remove assembly aids!
- Lower groups of heavy-duty props evenly in small steps.
 - Monitor the load distribution on the manometer.
 - The cylinder stroke is limited to max. 10 mm by the adjusting nut and hold-down device.
- Illustrations are without the connection plate and Heavy-Duty Prop HD.

Requirement

- The pump (11.1) is connected to the hydraulic cylinder (11.2). The cylinder is retracted.
- The pump valve (11.3) is closed. (Fig. A5.05)

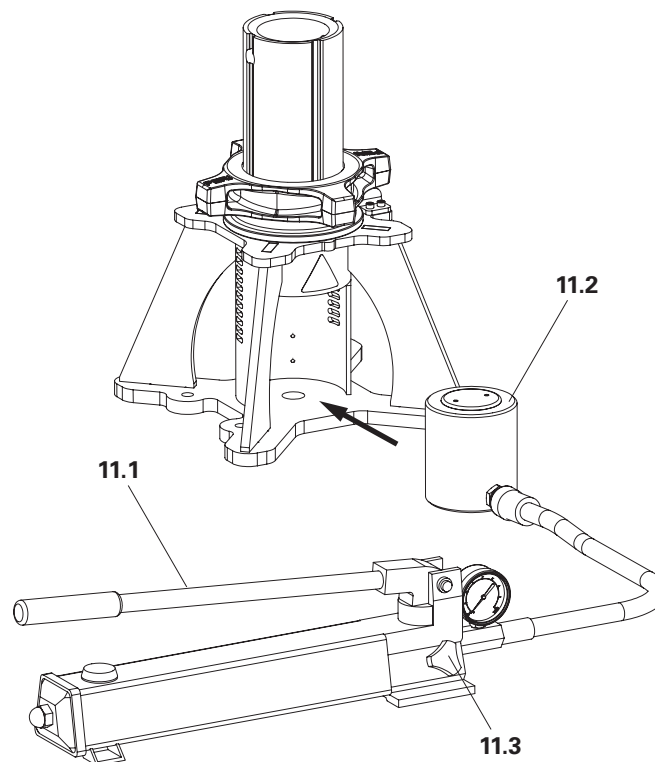

Fig. A5.05

Lowering the prop

1. Insert the hydraulic cylinder (**11.2**) into lowering jack (**1**).
2. Operate the pump lever until the cylinder is resting on the red pressure piece (**1.1**) of the spindle tube. (Fig. A5.06)
3. Continue pumping until the adjusting nut (**1.2**) is free of load (approx. ½ pump stroke).
→ Monitor manometer: max. 200 kN. (Fig. A5.06a)
4. Turn the adjusting nut upwards by hand in an anticlockwise direction until the adjusting nut is resting against the hold-down device (**1.3**). (Fig. A5.06b)
5. Carefully open the pump valve (**11.3**) on the pump and monitor the load indication on the manometer. Cylinder retracts and is lowered with the adjusting nut and prop by max. 10 mm. (Fig. A5.07 + A5.07a)
6. When the desired load is reached, close the pump valve.
7. Turn the adjusting nut downwards in a clockwise direction by hand until it is seated.
8. Open the pump valve (**11.3**), thereby relieving the hydraulics.
9. If the desired load is not reached within the 10 mm lowering distance, repeat steps 1-8, see structural analysis and lowering plan.

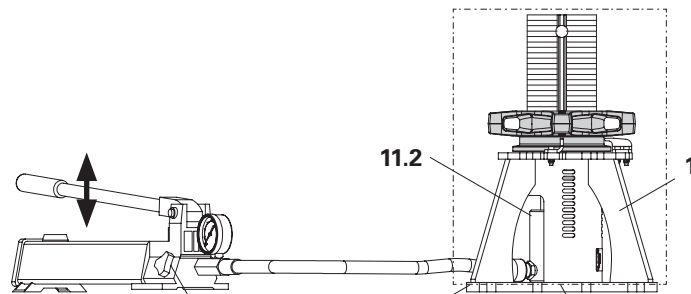

Fig. A5.06

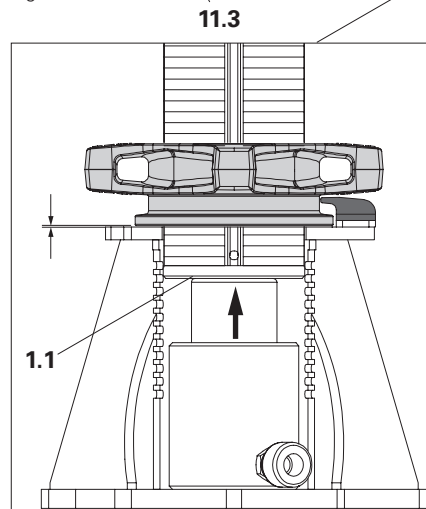

Fig. A5.06a

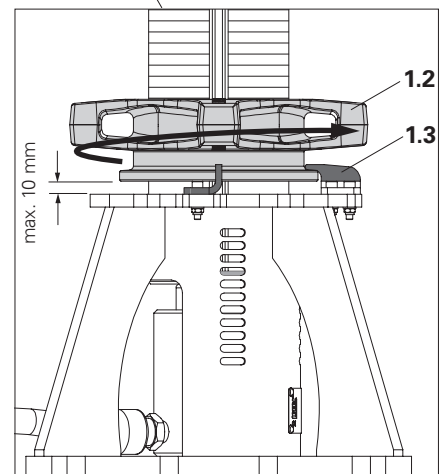

Fig. A5.06b

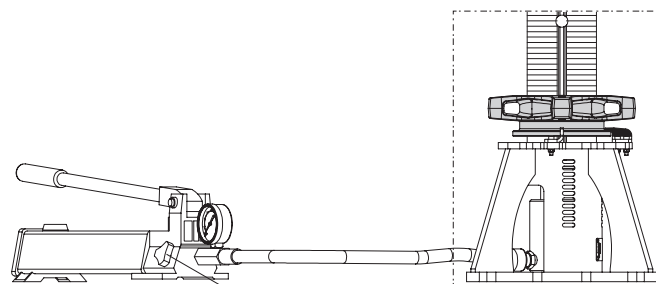

Fig. A5.07

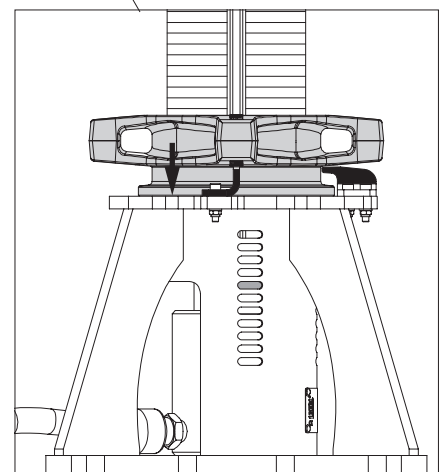

Fig. A5.07a

Displacement-controlled lowering

Hydraulic lowering



- Follow the Instructions for Use for the Hydraulic Lowering Unit HD!
- Lower groups of heavy-duty props evenly in small steps.
 - The cylinder stroke is limited to max. 10 mm by the adjusting nut and hold-down device.
 - This corresponds to the spacing of the slots in the lowering jack. (Fig. A5.08)
- Follow the lowering plan!
- Remove assembly aids!

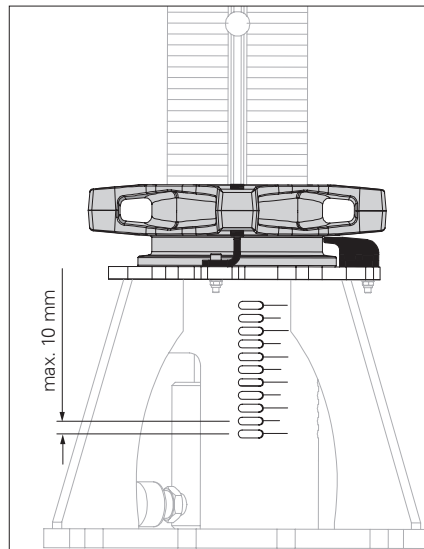

Fig. A5.08

Requirement

Load-controlled as in the lowering procedure.

Hydraulic lowering

1. Operate the pump lever until the cylinder is resting on the red pressure piece (1.1) of the spindle tube.
2. Continue pumping until the adjusting nut (1.2) is free of load (approx. ½ pump stroke).
3. Turn the adjusting nut upwards by hand in an anticlockwise direction until the adjusting nut is resting against the hold-down device.
4. Carefully open the pump valve (11.3) on the pump and monitor the slots on the lowering jack.
5. If the red pressure piece (1.1) of the spindle tube appears in the next slot, close the pump valve. (Fig. A5.09)
6. Repeat steps 3 and 4 until the prop or main beam frame is lowered by the specified amount.

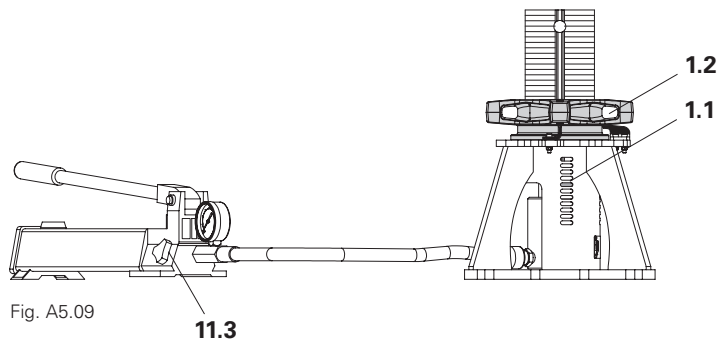

Fig. A5.09

Displacement-controlled lowering

Lowering with the Wingnut Spanner HD with low loads



- The lowering range via the lowering jack is 100 mm (starting position "slot 11").
- With a load ≤ 50 kN, lowering can be carried out using the Wingnut Spanner HD (8) without the use of hydraulics.
- The lowering range for extending the formwork superstructure is provided by the adjusting nut of the head spindle.

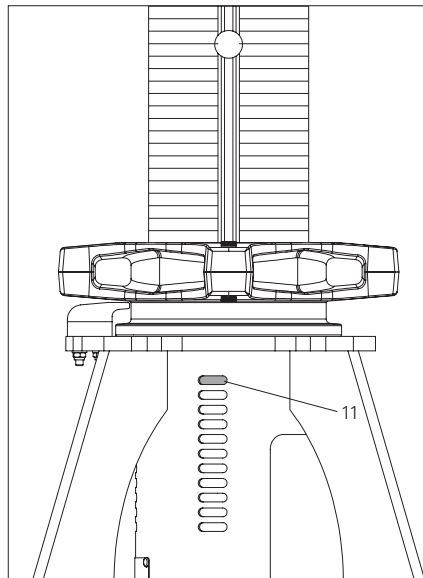

Fig. A5.10

Lowering

1. Turn adjusting nut (1.2) upwards with Wingnut Spanner HD (8). (Fig. A5.10a)
2. Spindle off the head spindle. (Fig. A5.10b)

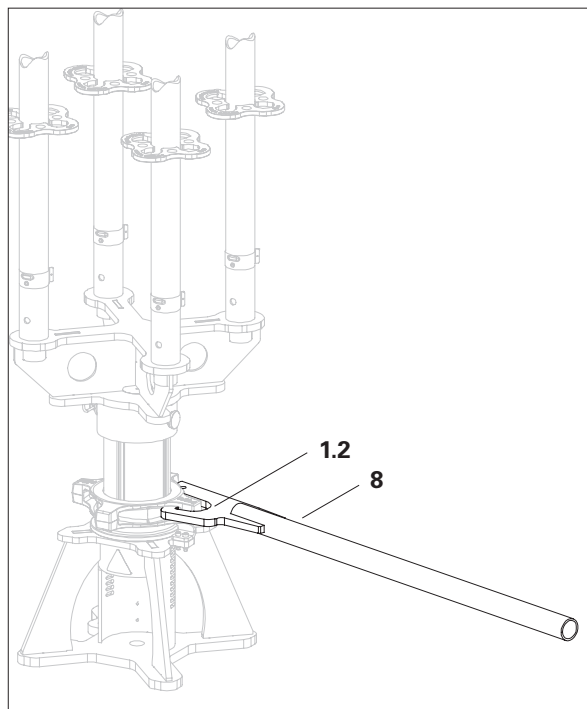

Fig. A5.10a

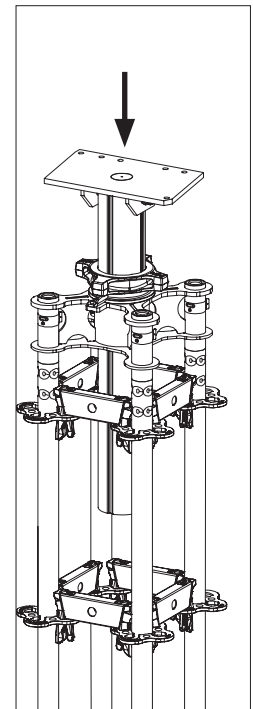

Fig. A5.10b

Warning

There is no safe working area during assembly!

Risk of falling!

⇒ Use personal protective equipment to prevent falling!

⇒ Use a working scaffold or cherry picker to assemble the components.



The load transfer of the Main Beam HDT as base and top beams must be verified on a project-specific basis in each case.

Overview

This section shows the assembly of a vertical Main Beam Frame with PERI UP Flex Heavy-Duty Props HD. In addition to the components of the PERI UP Flex Heavy-Duty Prop HD, the following components are required.

Additional components

- | | |
|-----------|---|
| 6 | Locking pin Ø 48/57 |
| 20 | Main Beam HDT 880 |
| 23 | Girder Clamp HD 70 |
| 30 | Ladder Cage 150 |
| 31 | Ladder Connector UAC-2 |
| 32 | Access Ladder 180/2 |
| 33 | Ladder 180/6 |
| 34 | Ladder base |
| 35 | Ladder hook |
| 40 | Console Bracket UCM 75 |
| 41 | Top Standard UVH-2 100 |
| 42 | Horizontal Ledger UH-2 (as connecting ledger) |
| 43 | Steel Deck UDG |
| 44 | Steel Toe Board UPY |
| 47 | Connector ULT 32 |
| 50 | Double Tie Yoke HDD |
| 51 | Tie Rod DW 15 |
| 52 | Wing Nut DW 15 |
| 53 | Cam Nut DW 15 |

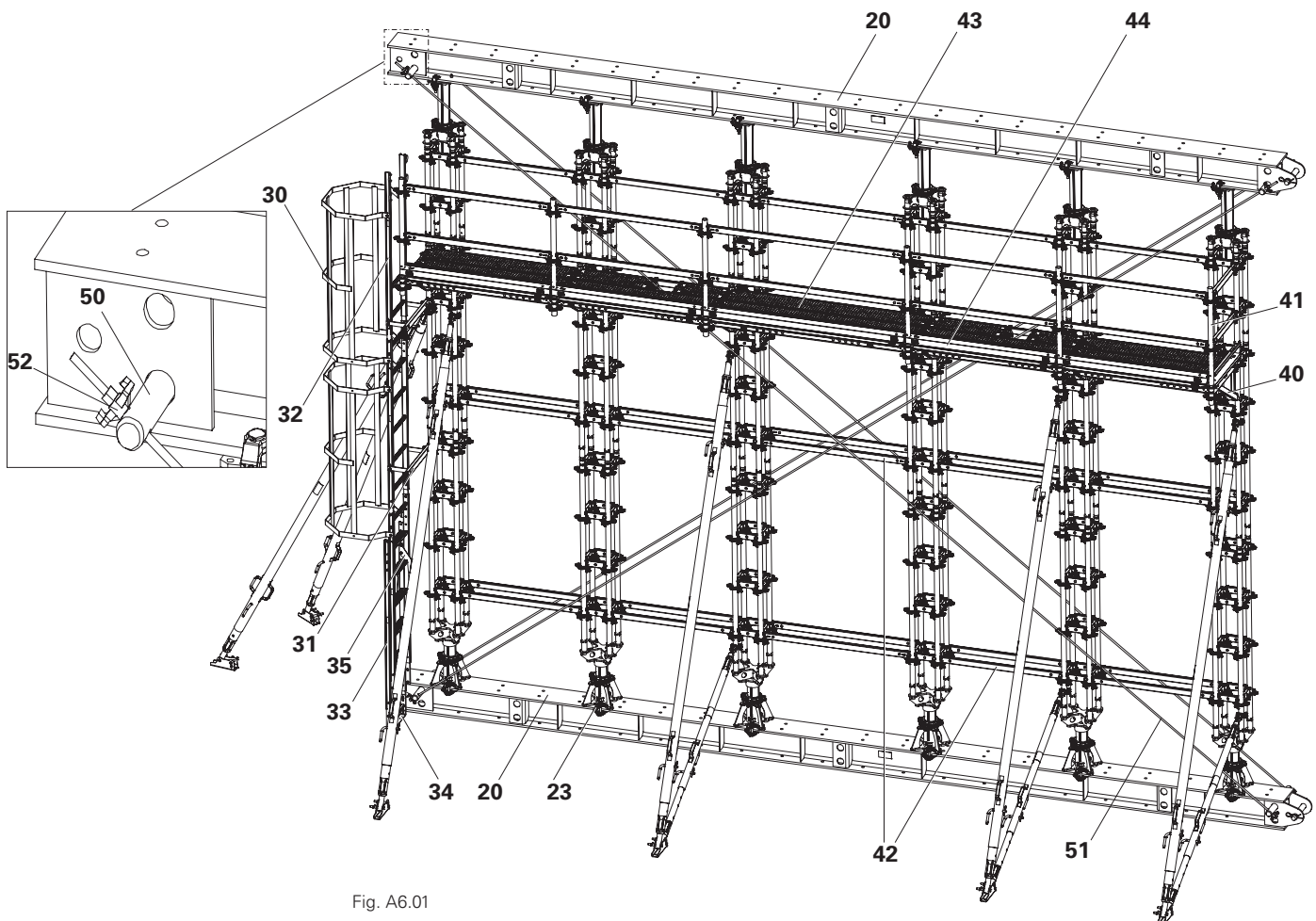

Fig. A6.01

Ladder access

Pre-assembly

Assemble the Heavy-Duty Prop HD as an individual prop, as in Section A2.

Assembly

1. Fit Connector ULT 32 (47) into Console Bracket UCM 75 (40) with locking pin \varnothing 48/57 (6). (Fig. A6.02)
2. Fit Console Bracket UCM 75 (40) in the required position. (Fig. A6.03 + A6.04)

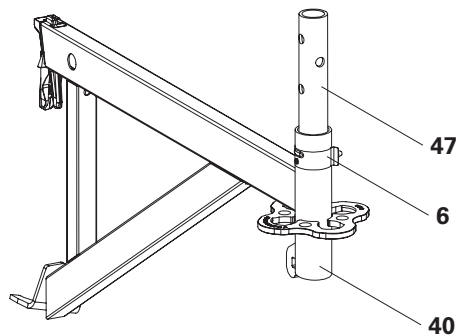

Fig. A6.02



- The assembly positions of the console brackets must be determined on a project-specific basis. Fit the first Console Bracket UCM 75 on the right leg of the first Heavy-Duty Prop HD.
- Fit additional Console Brackets UCM 75 on a project-specific basis, depending on the length of the decks on the respective left or right leg of the next Heavy-Duty Prop HD.

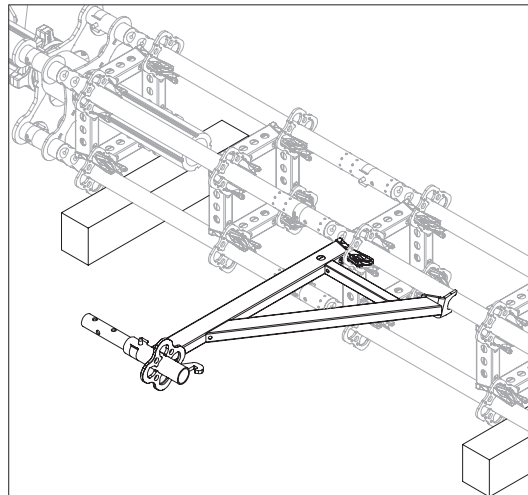

Fig. A6.03



For assembly details, see the PERI UP Scaffolding Kit assembly instructions.

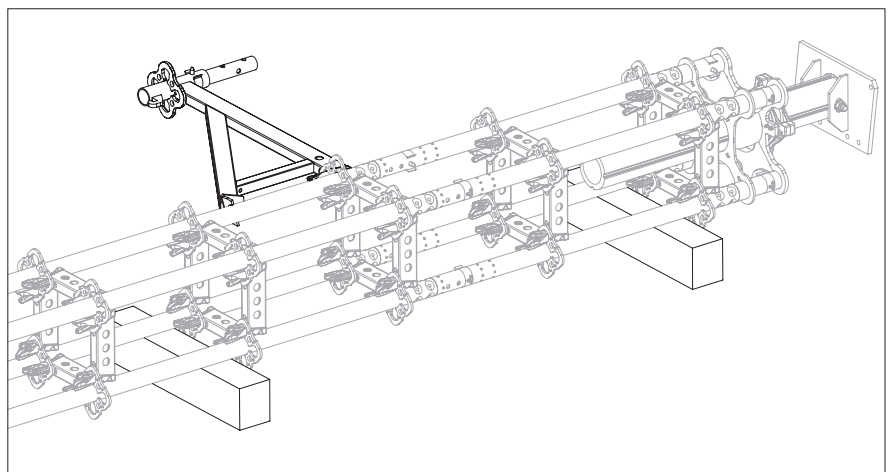

Fig. A6.04

A6 Vertical assembly of the main beam frame

3. Insert the Top Standard UVH-2 100 (**41**) as a guardrail post into the Console Bracket UCM 75 (**40**) and secure it with locking pins $\varnothing 48/57$ (**6**). (Fig. A6.05)
4. Hammer the Ladder Connectors UAC-2 (**31**) into the rosettes of the standards. (Fig. A6.06 + A6.06a)



The assembly positions of the ladder connectors must be determined on a project-specific basis.

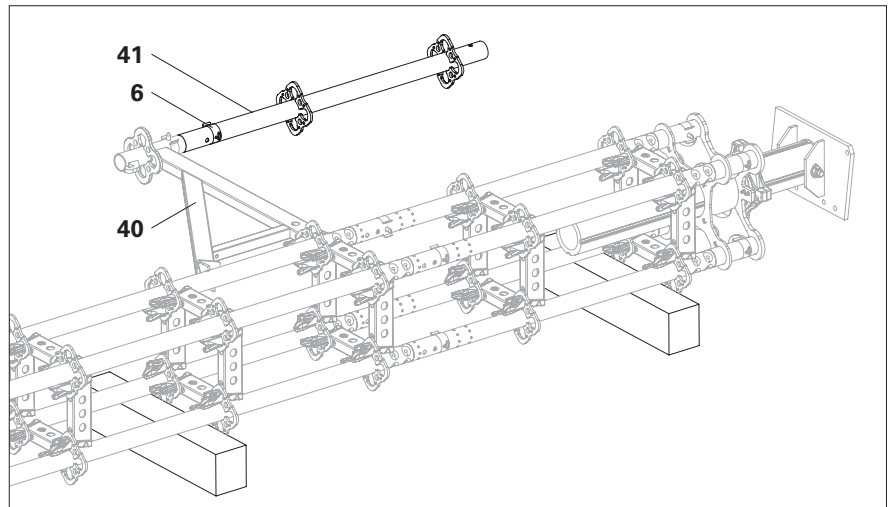

Fig. A6.05

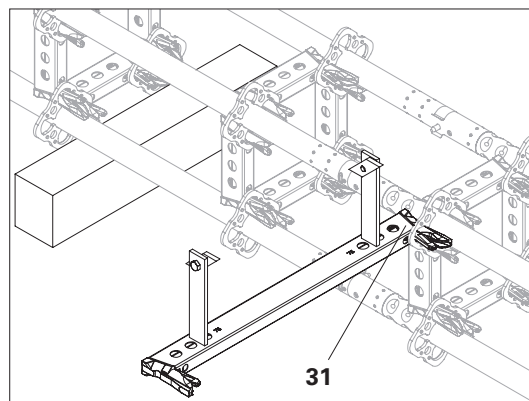

Fig. A6.06a

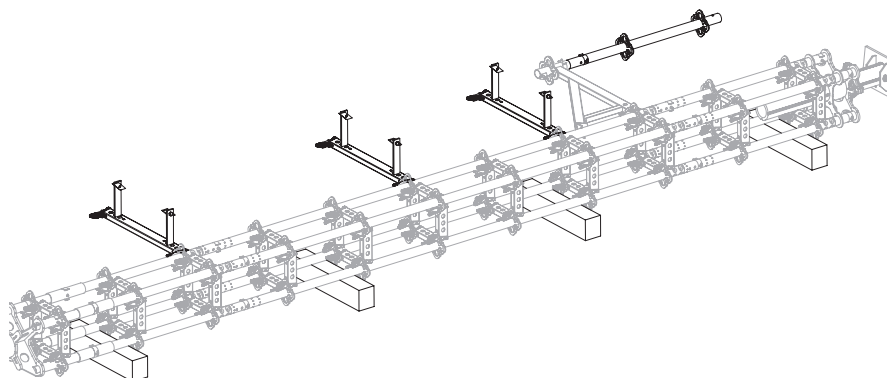

Fig. A6.06

A6 Vertical assembly of the main beam frame

5. Pre-assemble the ladder from access ladder 180/2 (**32**) and ladder 180/6 (**33**) to required length. (Fig. A6.07)
6. Attach the ladder base (**34**) and ladder hook (**35**). (Fig. A6.08)
7. Secure the ladder to ladder connectors with the clamping plates (**33.1**). (Fig. A6.09a)
8. Attach the ladder cage (**30**) to the ladder with the clamping plates. (Fig. A6.09 and A6.09a)

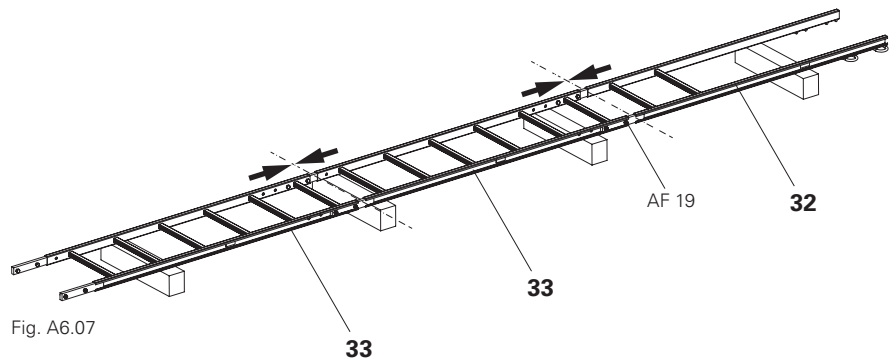

Fig. A6.07

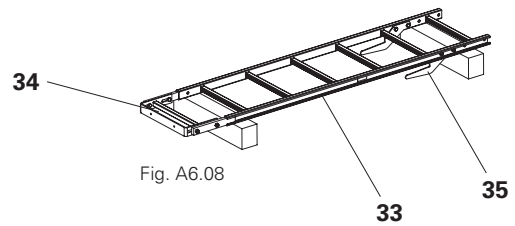

Fig. A6.08



- Do not attach the ladder cage in the area of the ladder joint.



- Is the contact surface of the clamping plates (**30.1/33.1**) in contact with the ladder profile? (Fig. A6.09a)
- Are the Top Standard UVH-2 100 (**41**) and the Console Bracket UCM 75 (**40**) tightly connected with the locking pin \varnothing 48/57 (**6**)? (Fig. A6.05)

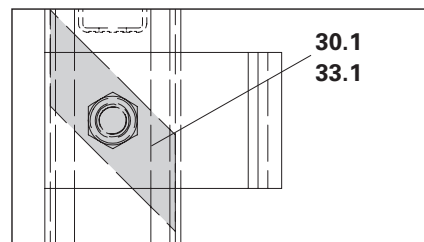

Fig. A6.09a



For assembly details, see the PERI UP Scaffolding Kit assembly instructions.

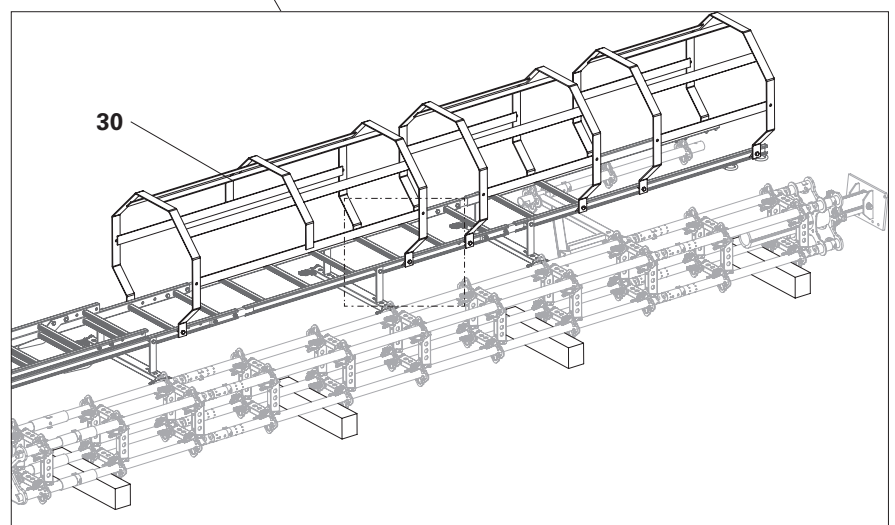

Fig. A6.09

Main Beam HDT as base beam



- Secure lifting gear, e.g. chains or textile strapping, against slipping.
- The load transfer of the Main Beam HDT as base and top beams must be verified on a project-specific basis in each case.

Assembly

1. Before positioning the Main Beam HDT as a base beam, remove the bolts (**20.1**) (observe distance to existing components).
2. Place the base beam (**20**) on the place of use (foundation). The beam must rest fully on a level and load-bearing substrate.
3. Depending on the length, connect and secure base beam with bolts and cotter pins (**20.1 + 20.2**). (Fig. A6.10)

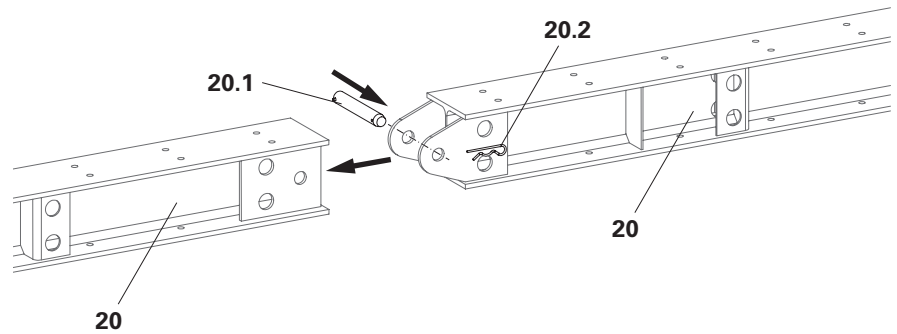

Fig. A6.10

Pre-assembly

Pre-assemble the required number of individual props for the required height according to the instructions in Section A2.

Lowering Jacks

Assembly

1. Place the required number of Lowering jacks (**1**) on the Main Beam HDT (**20**). (Fig. A6.11)
 2. Fix the first lowering jack with centring bolts (**21**) in the holes of the main beam and additionally secure with two opposing girder clamps (**23**). (Fig. A6.11a + A6.11b)
 3. Secure further lowering jacks with diagonally opposing girder clamps.
- At a distance of 1 m, it is possible to centre in holes of the main beam. To do this, fit the lowering jacks, each rotated by 180°, and then secure them with two opposing girder clamps (**23**). (Fig. A6.12)



Measure the dimension e at the straight base edges of the lowering jack (Fig. A6.12)

The horizontal ledgers to be used determine the distance between the lowering jacks. See table. The maximum horizontal ledger length is 1.50 m. (Tab. A6.01)

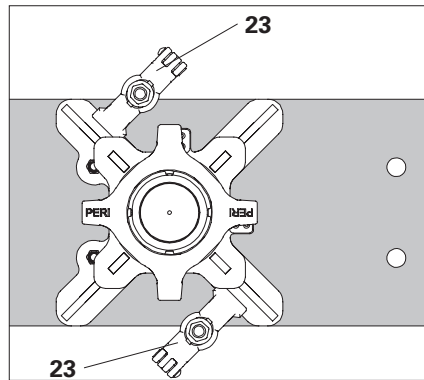

Fig. A6.11a

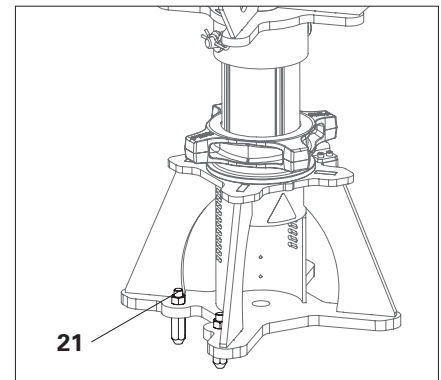

Fig. A6.11b

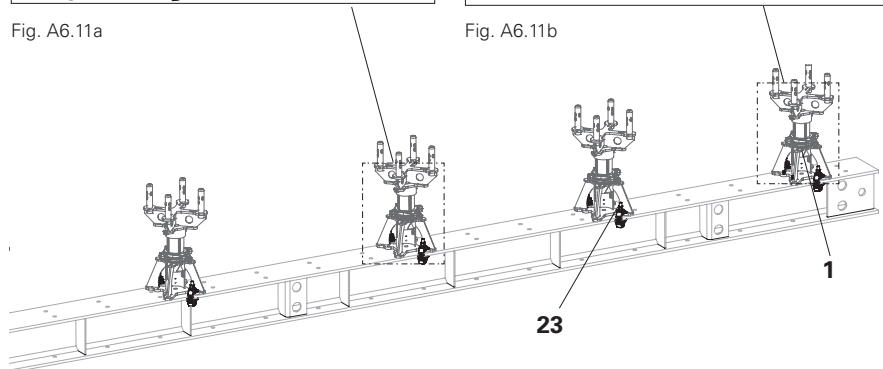

Fig. A6.11

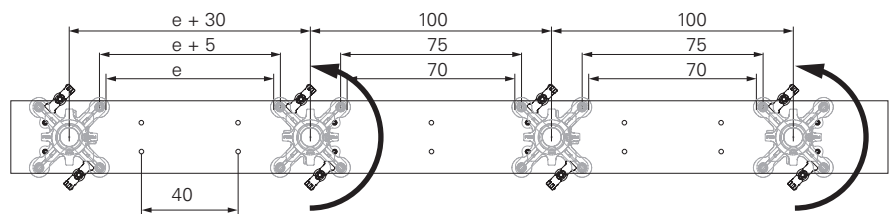

Fig. A6.12

Spacing table	
Horizontal Ledger UH-2 (= $e + 5$)	Spacing "e" between the lowering jacks [cm]
25	20.0
50	45.0
75	70.0
100	95.0
125	120.0
150	145.0

Tab. A6.01

First Prop

1. For pre-assembly of the Heavy-Duty Prop HD, see Section A2 "Horizontal assembly of individual props"
2. Lift and position the first Heavy-Duty Prop HD with mounted ladder, Console Bracket UCM 75 and Top Standard UVH-2 100 as guardrail posts onto the first lowering jack using a crane. (Fig. A6.13)
3. Support the Heavy-Duty Prop HD with three Push-Pull Props for the assembly. (Fig. A6.14 + A6.14a) See Section A3 "Bracing with push-pull props"



Fit Push-Pull Props RS at the nearest possible position on the Heavy-Duty Prop HD below the Console Bracket UCM 75.

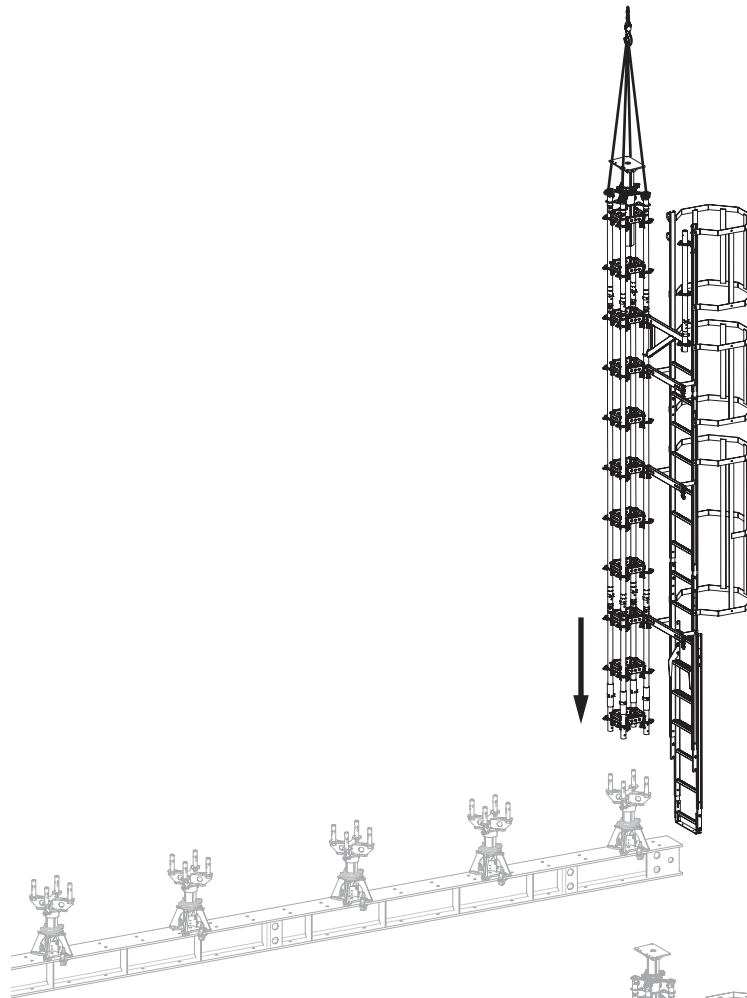

Fig. A6.13

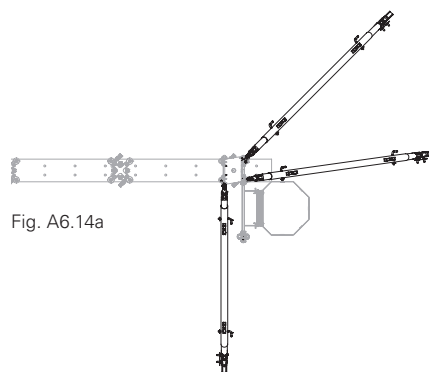

Fig. A6.14a

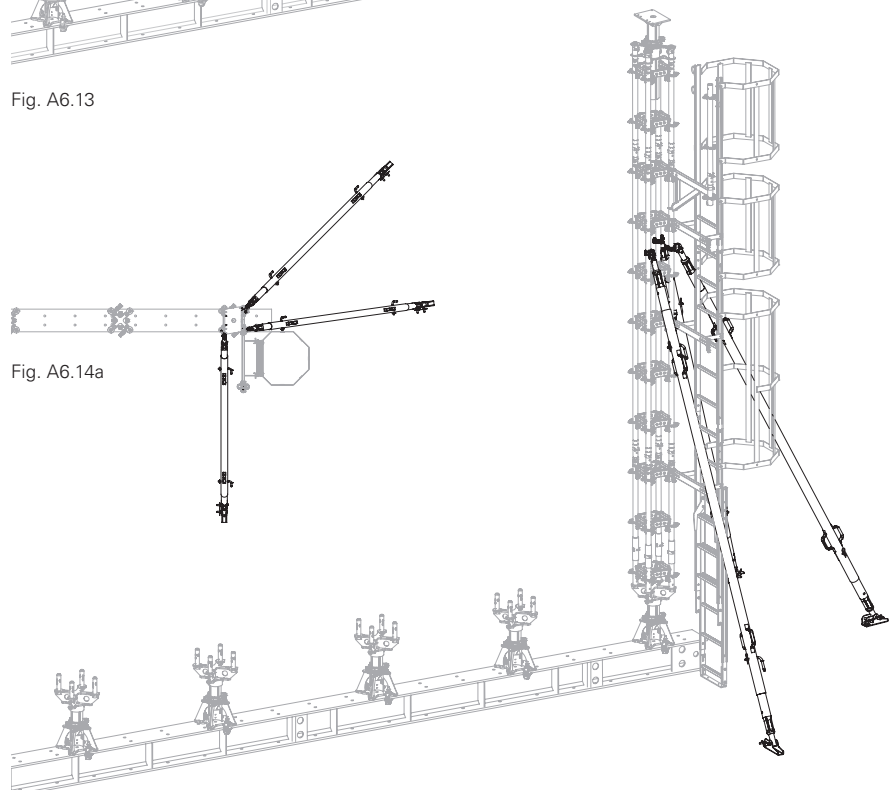

Fig. A6.14

Additional props

-
- 16** Horizontal Ledger UH-2
(as connecting ledger)
 - 12** Push-Pull Prop RS
-

Assembly

1. Lift and position the second Heavy-Duty Prop HD with mounted Console Bracket UCM 75 (**40**) and guardrail posts onto the second Lowering Jack with a crane. Leave the Heavy-Duty Prop HD suspended on the crane lifting gear.
2. First install horizontal ledgers (**16**) in the rosettes of the second level as an assembly aid (max. 1.50 m). Subsequently, the spacing of the horizontal ledgers (**16a**) at the top must not exceed 2.50 m. (Fig. A6.15) For more information see Section A6 "Work Platform".

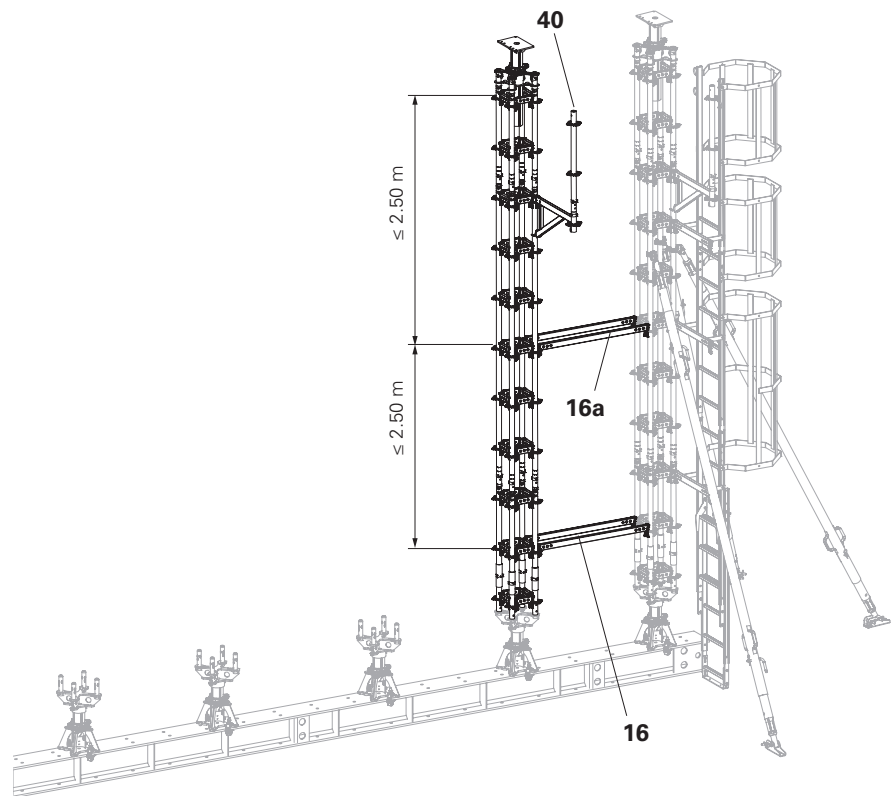

Fig. A6.15

A6 Vertical assembly of the main beam frame

3. Erect the third Heavy-Duty Prop HD. Fit a Push-Pull Prop RS (**12a**) to this and every second subsequent Heavy-Duty Prop HD. Fit Push-Pull Props RS at the nearest possible position on the Heavy-Duty Prop HD below the Console Bracket UCM.
4. Repeat steps 1. to 3. until the desired number of Heavy-Duty Props HD are installed on the main beam frame.
5. Always fit the final Heavy-Duty Prop HD in the main beam frame with push-pull props. (Fig. A6.16)



If Heavy-Duty Props HD are not fitted with centring pins, they must be supported with push-pull props (**12a**) and kicker braces (**12b**).

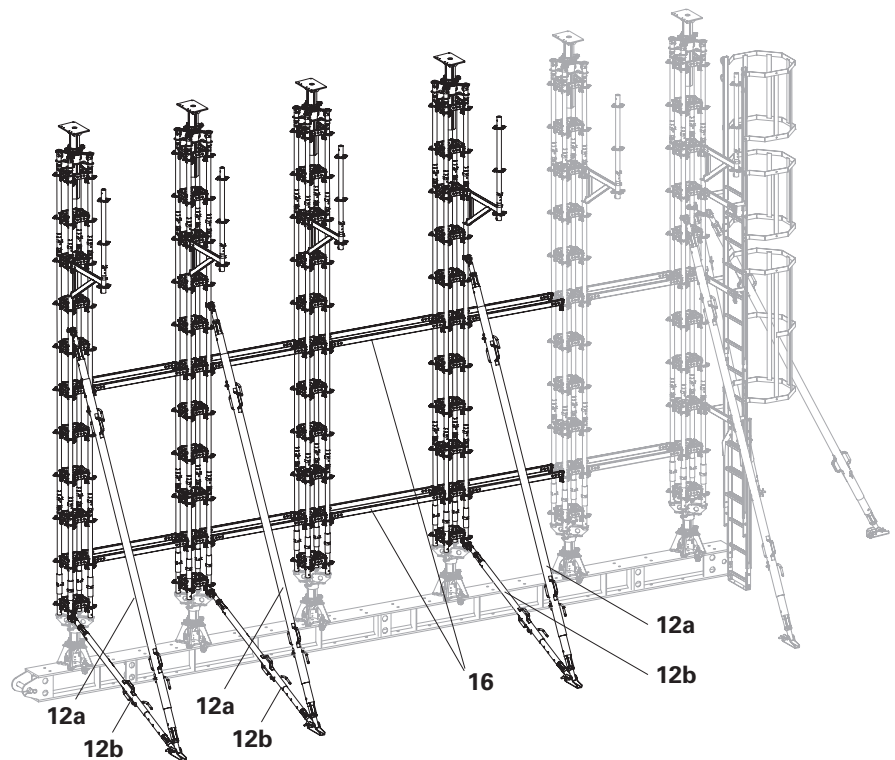

Fig. A6.16

Work platform

Components

- 16** Horizontal Ledger UH-2
- 43** Steel Deck UDG-2
- 44** Steel Toe Board UPY

Attachment points for PPE

The rosettes (**5.1**) of the standards that are on the level of the work platform and only the Heavy-Duty Props HD that are held with at least one Push-Pull Prop RS. (Fig. A6.17 and Fig. A6.18)

Assembly

1. Attach the Steel Decks UDG-2 (**43**) to the pre-assembled Console Bracket UCM 75 (**40**).
2. Mount the horizontal ledgers (**16**) on the guardrail posts as anti-fall protection and attach the Toe Board Steel UPY (**44**) (Fig. A6.17)
3. Fit additional steel decks (**43**), horizontal ledgers (**16a**) and Toe Boards UPY (**44**). (Fig. A6.18)
Leave recesses in the deck level for the diagonal bracing. Determine the position of the recesses on a project-specific basis. (Fig. A6.18a)

Alternative

- Assembly of a PERI UP Flex Working Scaffold.
- Lifting work platform.

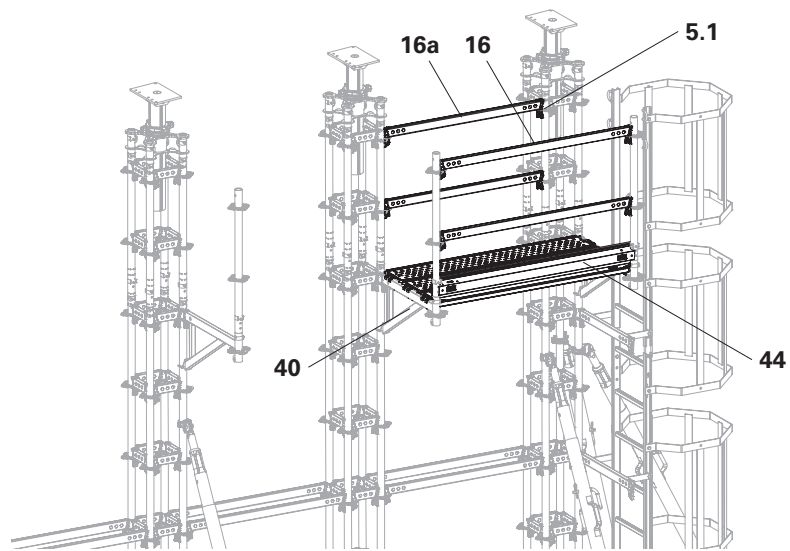

Fig. A6.17

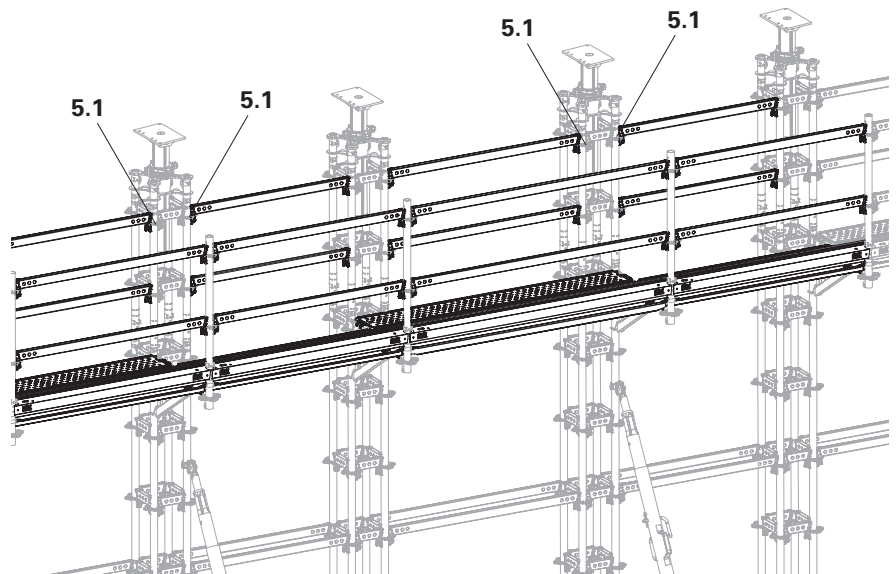

Fig. A6.18

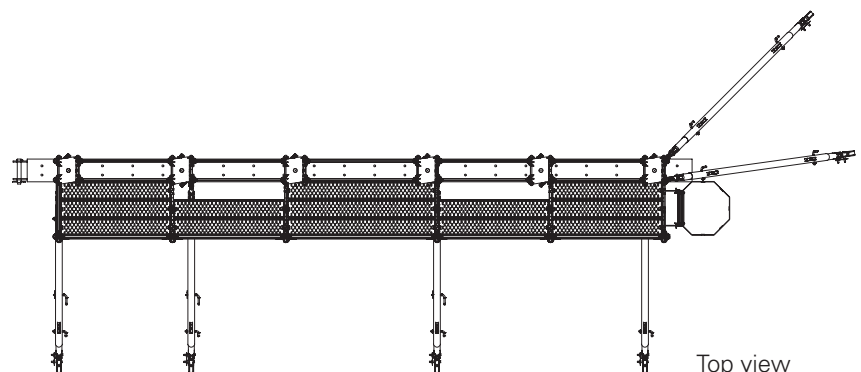

Fig. A6.18a

Forming recesses in the decks

Components

- 16** Horizontal Ledger UH-2
- 43** Steel Deck UDG-2
- 44** Steel Toe Board UPY
- 45** Deck Traverse UDT 25
- 47** Inside Corner Plate EDP

If a work platform is mounted on the main beam frame, two recesses must be made for the tie rods. The position of the recesses must be planned specifically for the project.

Assembly

1. As far as possible, line the bay concerned with Steel Decks UDG-2 (**43**).
2. Between the adjacent heavy duty props, fit a steel deck (**43a**) to existing horizontal ledgers (**4**).
3. Fit one Deck Traverse UDT 25 (**45**) to the right and one to the left of the required recess. (Fig. A6.19a)
4. Attach two steel decks (**43b**), tailored to the remaining length, to console bracket (**40**) and deck traverse (**45**). Use additional cover plates, for example Inside Corner Plate EDP (**47**), to suit the positioning.



For further options for closing gaps in the decking, see the assembly instructions for the core components of the scaffolding kit.

→ The work platform is ready.

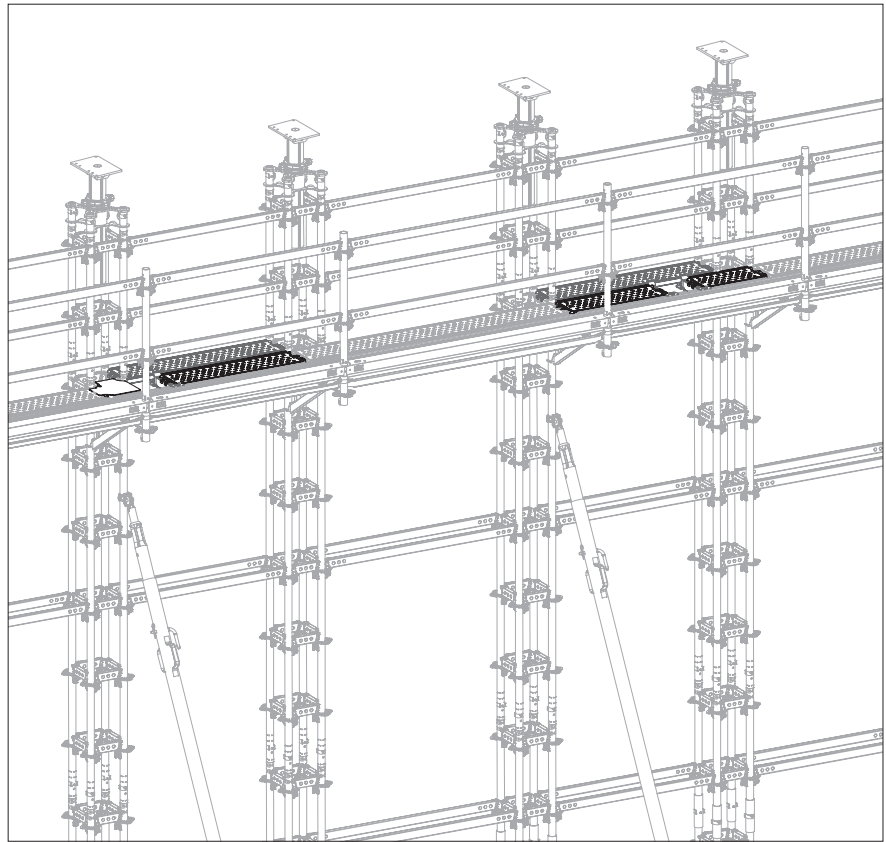

Fig. A6.19

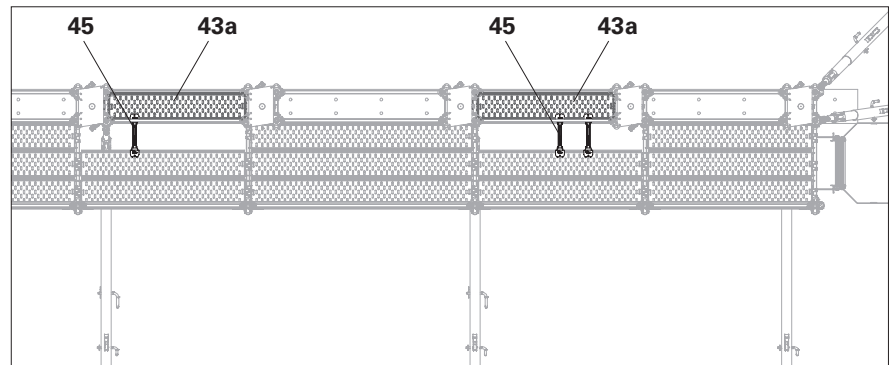

Fig. A6.19a

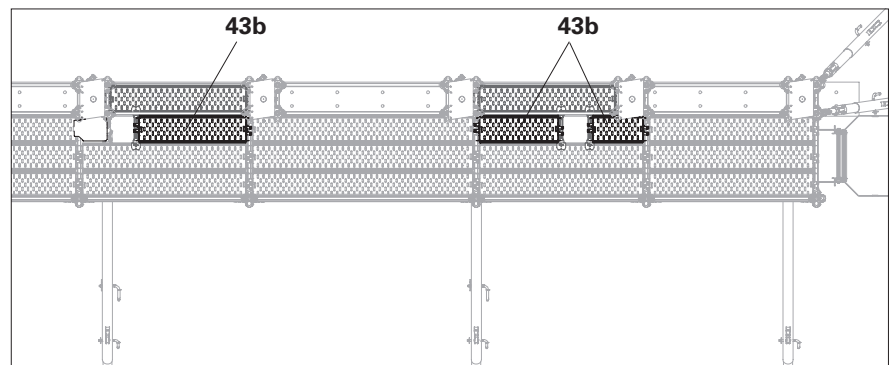

Fig. A6.19b



Head spindles

- First and last Heavy-Duty Props HD with Push-Pull Prop RS (12) as primary props: spindle out head spindle approx. 10 mm above the specified dimension. In this way, the target dimension can be conveniently set by way of spindling with the main beam resting on top.
- Other Heavy-Duty Props HD as intermediate props: head spindles remain 50 mm below specified dimension.

The Main Beam HDT is first placed on the primary props to ensure that the mounting process is secure. See Section A6 "Top beam".

Articulated head plates

To secure the position of the Main Beam HDT (20), 2 centring bolts (21) are fitted in each of the articulated head plates (7.1) of the head spindles.

If possible, use the inner holes (7.2) of the articulated head plate and centre it via the holes in the main beam (20.3). (Fig. A6.21a + A6.22a)

If the layout of the heavy-duty props does not allow this, then bolt the centring bolts into the lateral holes (7.3) of the articulated head plates and centre the main beam in this way (20.4). (Fig. A6.21 + A6.22)

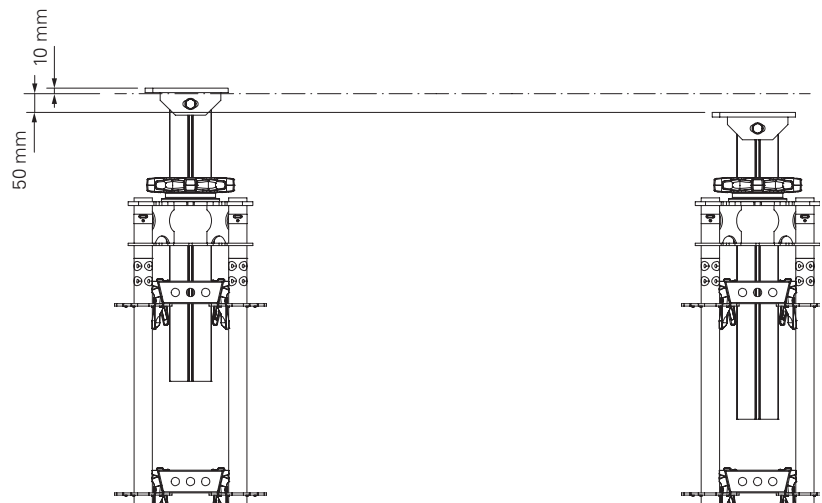

Fig. A6.20

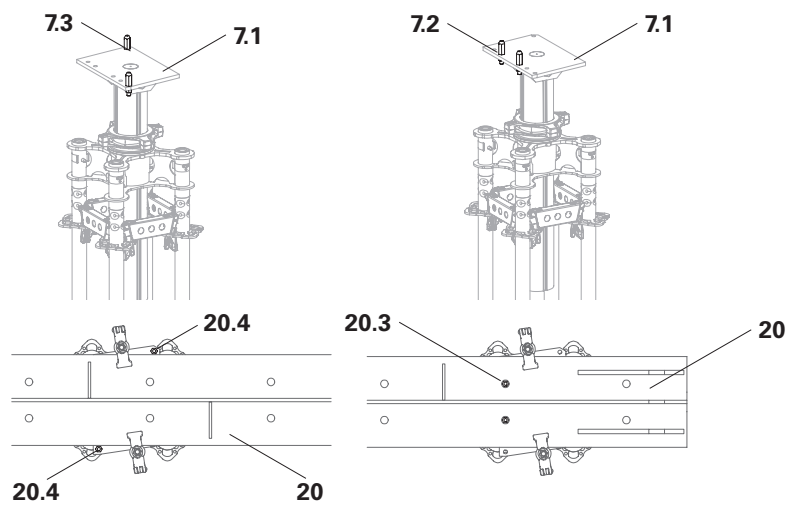

Fig. A6.21

Fig. A6.21a

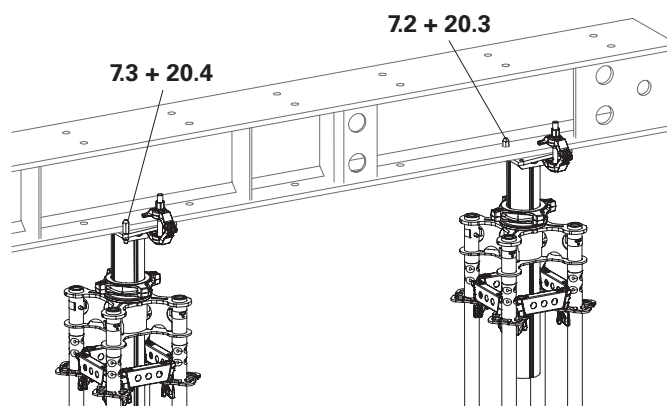

Fig. A6.22

Fig. A6.22a

Top beam

The Main Beam HDT is used as the top beam.



- The load transfer of the Main Beam HDT as base and top beams must be verified on a project-specific basis in each case.
- To fit the top beam safely, install a work platform with access point. See Section A6 "Work platform".
Alternatively:
 - Assembly of a PERI UP Flex Working Scaffold.
 - Cherry picker.

Components

10	Heavy-Duty Prop HD
20	Main Beam HDT
21	Centring bolts
23	Girder Clamp HD 70

Assembly

1. Attach the main beam (20) with a round sling to prevent it from slipping.
2. Place the Main Beam HDT on the primary props (10a). (Fig. A6.23)
3. Centre the articulated head plate with the main beam using the centring bolts (7.2).
4. Fix the main beam to the articulated head plate with girder clamps (23). (Fig. A6.23a - A6.23c)
Level the head spindles (7a) of the primary props to the target dimension.
5. Spindle the head spindles (7b) of the intermediate props up to the Main Beam HDT (20).
6. Centre the articulated head plates with the centring bolts (7.3).
7. Fix the main beam to the articulated head plate with girder clamps (23). (Fig. A6.23a - A6.23c)
→ The main beam is mounted.
8. Undo the round sling.

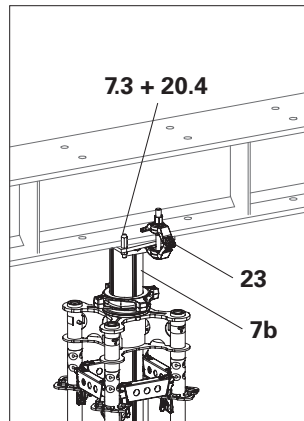

Fig. A6.23a

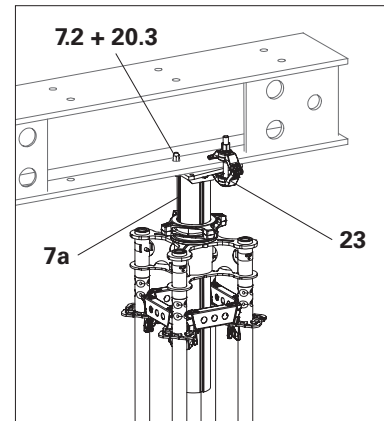

Fig. A6.23b

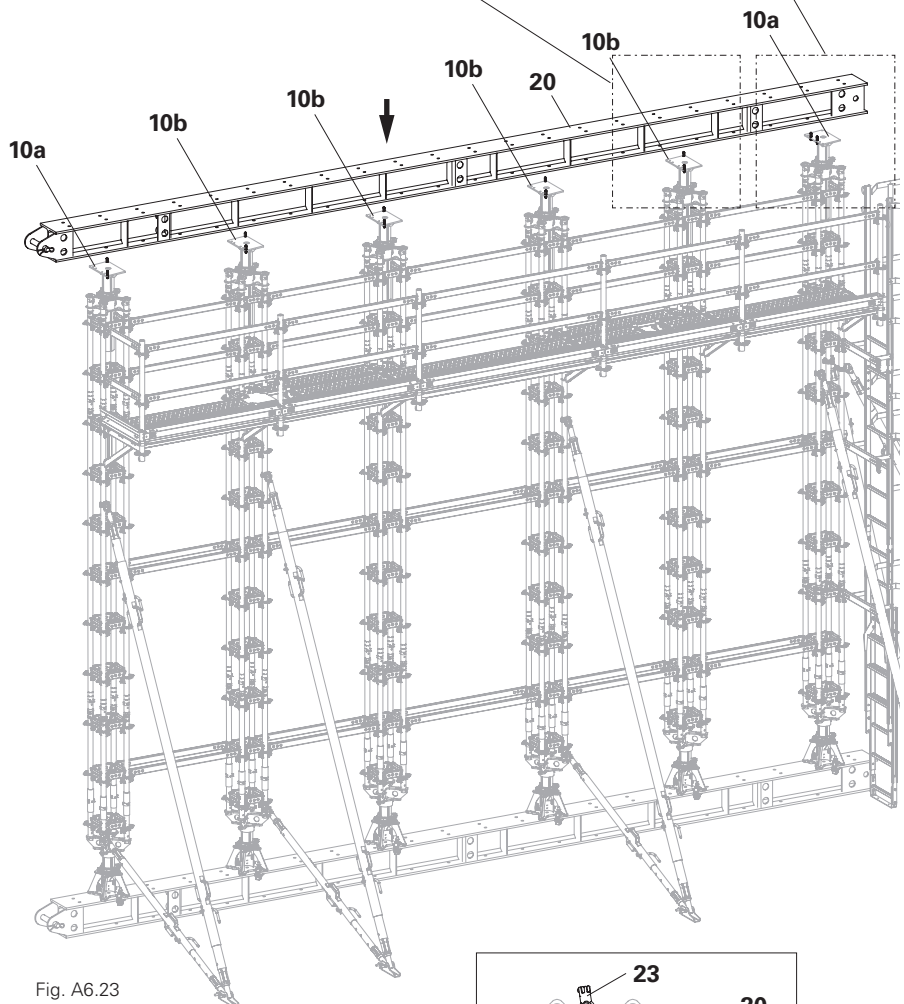

Fig. A6.23

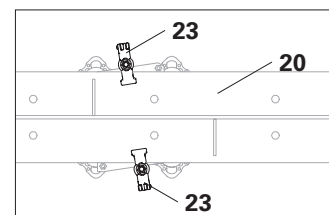

Fig. A6.23c

Diagonal bracing



Before positioning cross girders or prefabricated girders, fit horizontal bracing in the transverse direction of the main beam frame as statically required.

Mount diagonal bracing on both sides of the main beam frame to stabilise and transfer horizontal loads (Fig. A6.24)

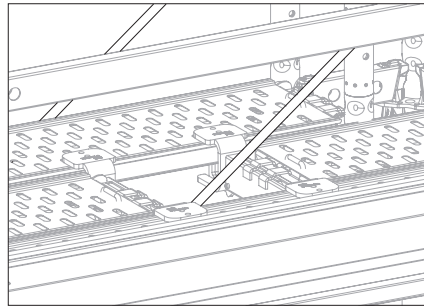

Fig. A6.24b

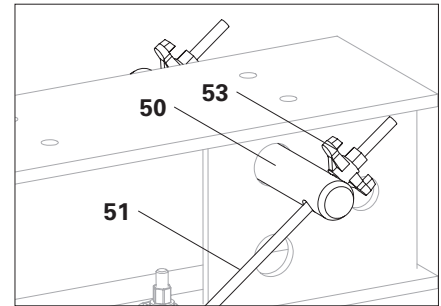

Fig. A6.24a

Components

- 50** Double Tie Yoke HDD
- 51** Tie Rod DW 15
- 52** Wing Nut DW 15
- 53** Cam Nut DW 15

Assembly

1. Insert the double tie yoke (**50**) into the main beams and ensure symmetrical overlap on both sides.
2. Insert Tie Rod DW 15 (**51**) diagonally on both sides. (Fig. A6.24a)



In each case, the change in length of the Tie Rod DW 15 must be statically checked. If necessary, use Tie Rod DW 20.

3. Ensure uniform tensioning using a wing nut or cam nut (**53**).
→ The diagonal bracing is now completed.

→ The main beam frame is ready.

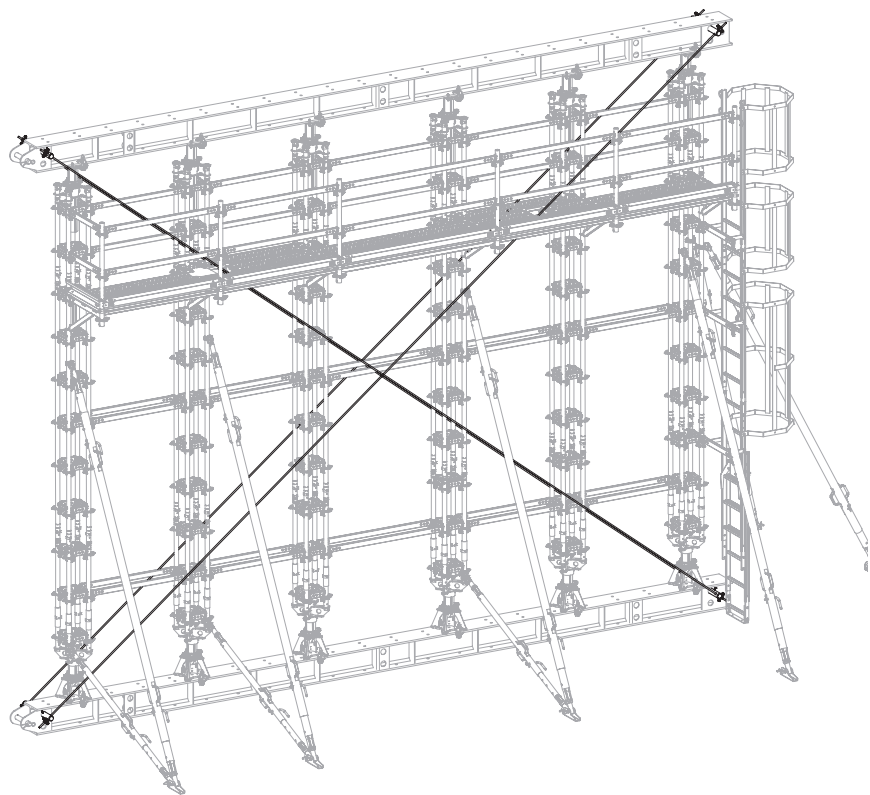

Fig. A6.24



Warning

Parts may fall off at any time in the dismantling process. These could strike people and seriously injure them.

- ⇒ Cordon off the area below the working area.
- ⇒ Dismantling is carried out from a safe working position, e.g. using the PERI UP Flex Working Scaffold.
- ⇒ Remove loose parts immediately or secure them against falling.

General information



- Lower the prop segments evenly as described in Section A5 to prevent overloading of the individual props.
- A project-specific lowering plan must be prepared for each dismantling operation. The described procedure must be followed.
- Retract the push-pull props (12) while the lowering process is being carried out in order to maintain the vertical alignment of the main beam frame.

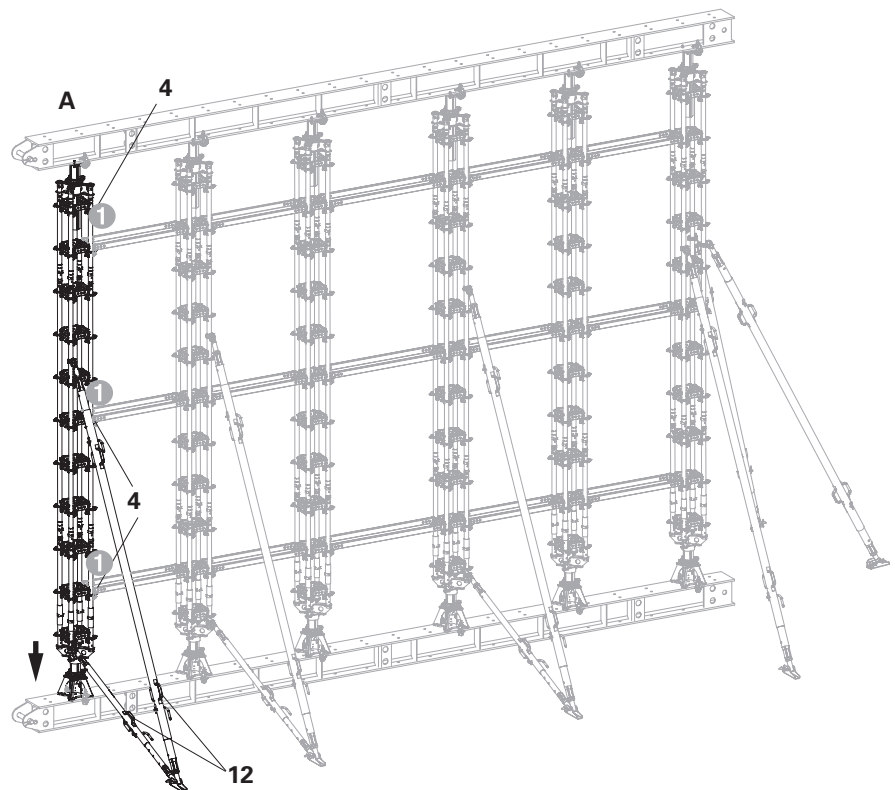

Fig. A7.01

A7 Dismantling the main beam frame vertically

Positioning free of any load



The lowering sequence described in the lowering plan must be adhered to. The sequence described is exemplary.

1. Remove the diagonal bracing.
2. Release the wedges ① of the Horizontal Ledgers UH-2 on the side of the Heavy-Duty Prop HD (A) being lowered.
Do **not** release wedges ②.
3. Lower the Heavy-Duty Prop HD (A). (Fig. A7.01)
4. Release wedges ③.
Do **not** release wedges ④.
Lower the Heavy-Duty Prop HD (B).
→ Horizontal ledger ① is lowered back onto the rosettes of Heavy-Duty Prop HD A
5. Hammer wedges ① into place. (Fig. A7.02)
6. Release wedges ⑤.
Do **not** release wedges ⑥.
Lower the Heavy-Duty Prop HD (C).
→ Horizontal ledger ③ is lowered back onto the rosettes of Heavy-Duty Prop HD B
7. Hammer wedges ③ into place.
8. Lower the other heavy-duty props in the same way.
9. Adjust the extension length of the push-pull props.
10. Repeat steps 2-8 until the main beam frame is free of any load. (Fig. A7.03)

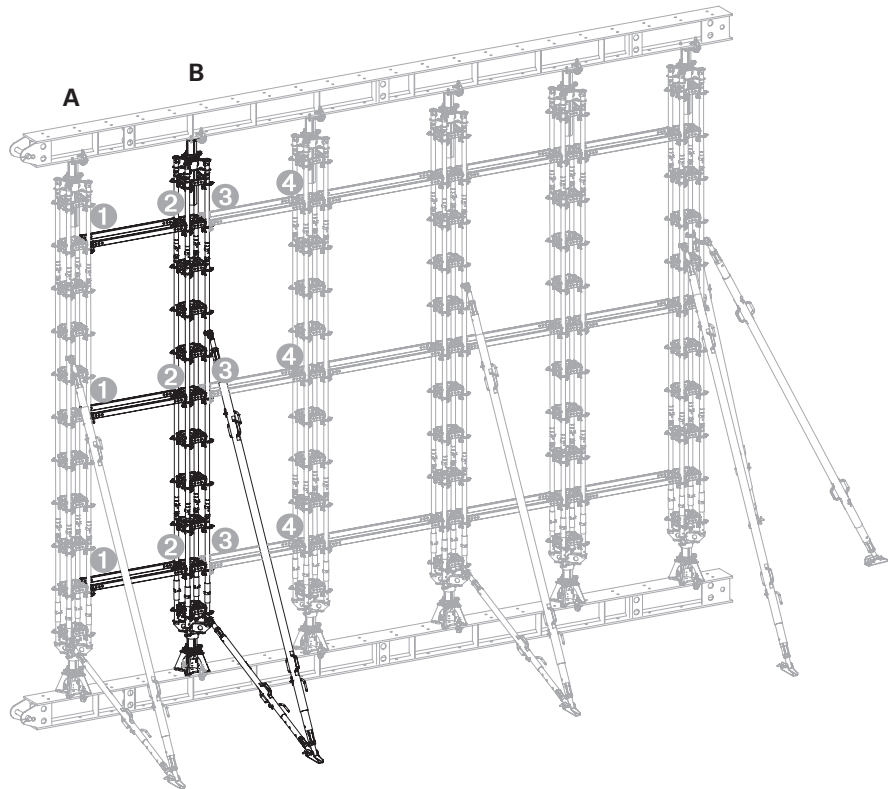

Fig. A7.02

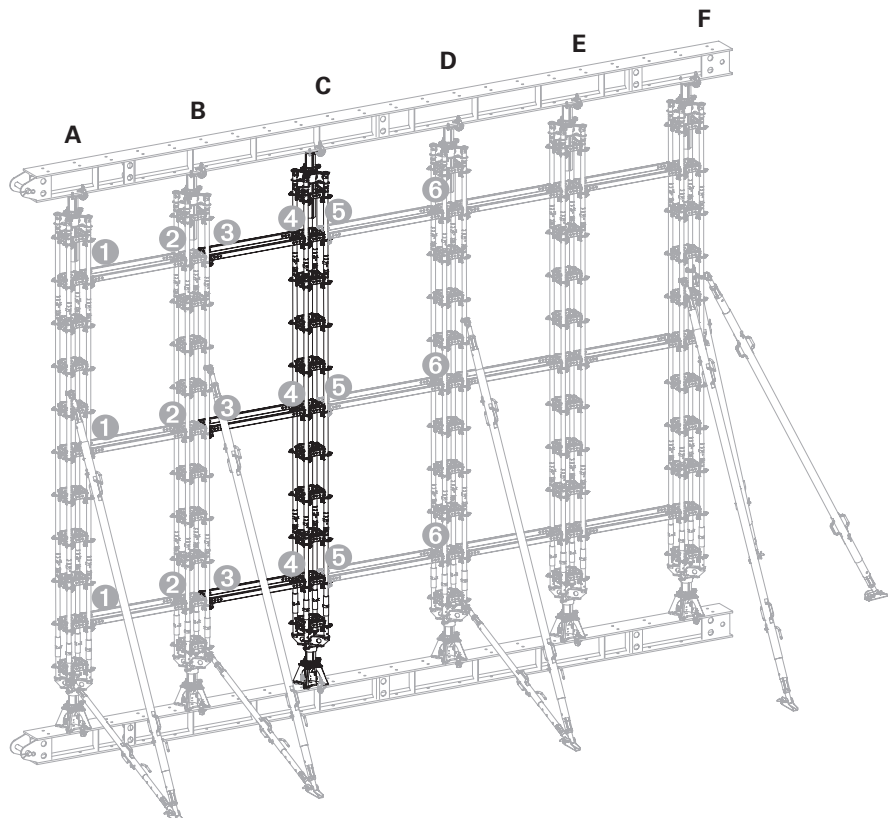

Fig. A7.03

Lowering

1. Remove the Girder Clamp HD 70 (23) from the Head Spindle TR 110-80/55 (7) of the heavy-duty props B to E.
2. Unscrew the head spindles with the spindle nut (7.1) until there is sufficient clearance for disassembly.
3. Lower heavy-duty props A and F at the head spindles. (Fig. A7.05a)

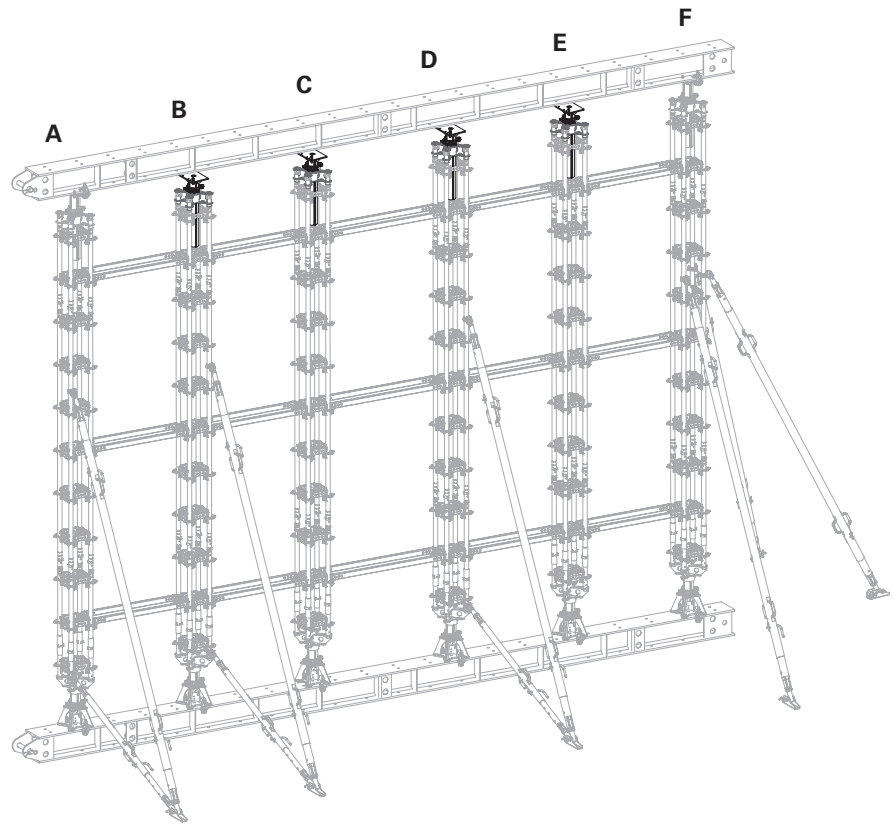

Fig. A7.05

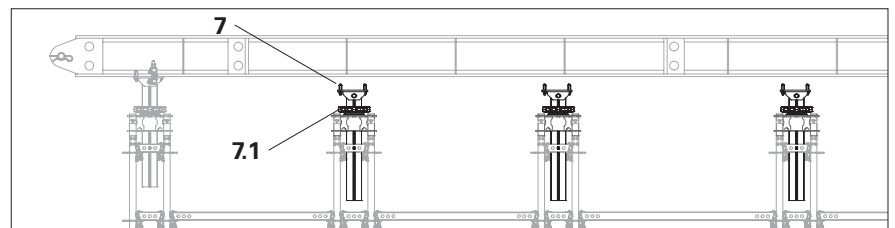

Fig. A7.05a

Removing the cross girders

Before removing the cross girders, first remove the formwork (70).

If it is not possible to remove the cross girders directly under the supporting structure, the trolley (25) can be used.

Always use two trolleys at the same time!

Components

25 The trolley consists of:

25.1 Cross tube

25.2 Longitudinal profiles

25.3 Lever

25.4 Cam nut

22 Cross girder

Assembly

1. Remove cross tube (25.1) from the trolley (25). (Fig. A7.07)
2. Push the trolley (25) under the cross girder (22) onto the Main Beam HDT (20) and fix the cross tube (25.1).
3. Tighten the cam nuts (25.4) evenly until the longitudinal profiles (25.2) are in contact with the cross girder (22). (Fig. A7.08)

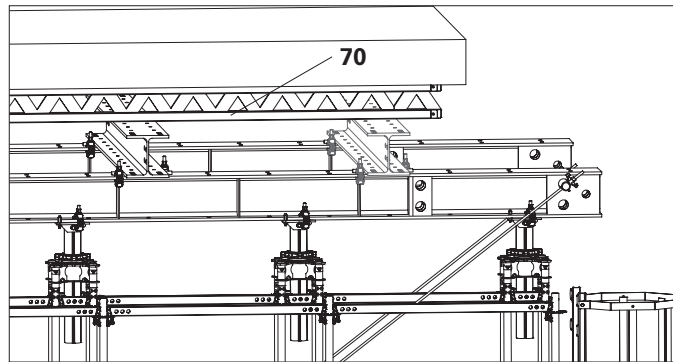

Fig. A7.06

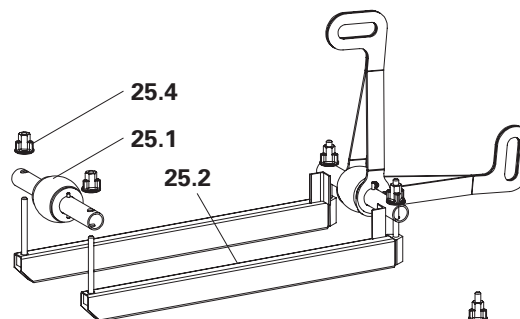

Fig. A7.07

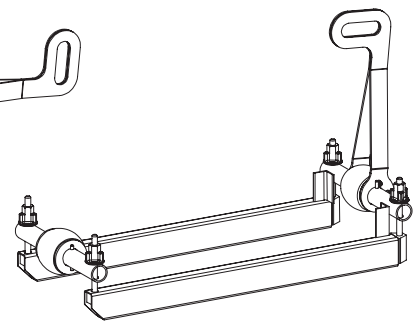

Fig. A7.07a

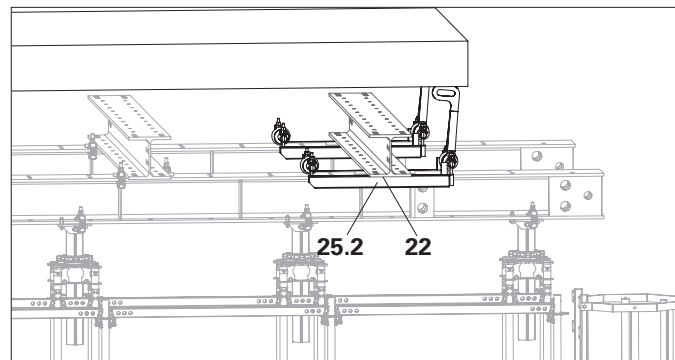

Fig. A7.08

Moving the cross girders



Warning

When the cross girders are moved out, pinch points are formed on all moving parts. Hands can get trapped, resulting in serious injuries.

- ⇒ Move the trolley by the handle only.
- ⇒ Keep your hands away from the girders and the trolley.
- ⇒ Do not reach between the main beam and the cross girder.
- ⇒ Be mindful of other people.
- ⇒ Stop the procedure by lifting the lever upwards.

1. Push the lever **(25.3)** downwards, the cross girder **(22)** is then lifted by approx. 5 mm.
2. If installed, remove centring rails **(24)**. (Fig. A7.09)
3. Extend the cross girders on the Main Beams HDT **(20)**.
4. At the end position, swivel the lever **(25.3)** upwards to lower the cross girder again. (Fig. A7.09a)
5. Remove the trolley and remove the cross girders, for example with a crane.

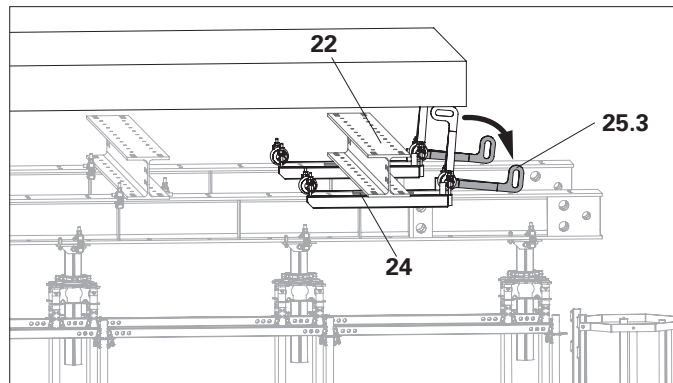

Fig. A7.09

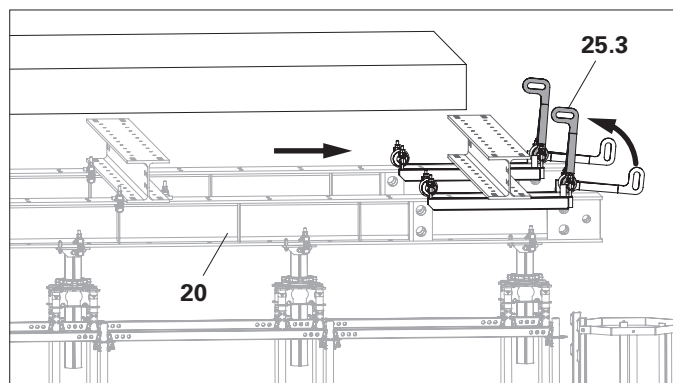

Fig. A7.09a

Removing the top beam

1. Attach the top beam (20) securely to a crane or other lifting device and take up the load with the lifting device.
2. Remove Girder Clamps HD 70 (23).
3. Lift the top beam away.

Removing the main beam frame



Warning

The main beam frame may topple over if the dismantling sequence is incorrect. This could seriously injure people or result in fatalities.

- ⇒ Follow the dismantling sequence from A to F.
- ⇒ Do not remove push-pull props until the relevant heavy-duty prop is securely attached to the crane.
- ⇒ Use the work platform as a safe access point and remove the props one by one. Ensure that there is front-side protection.

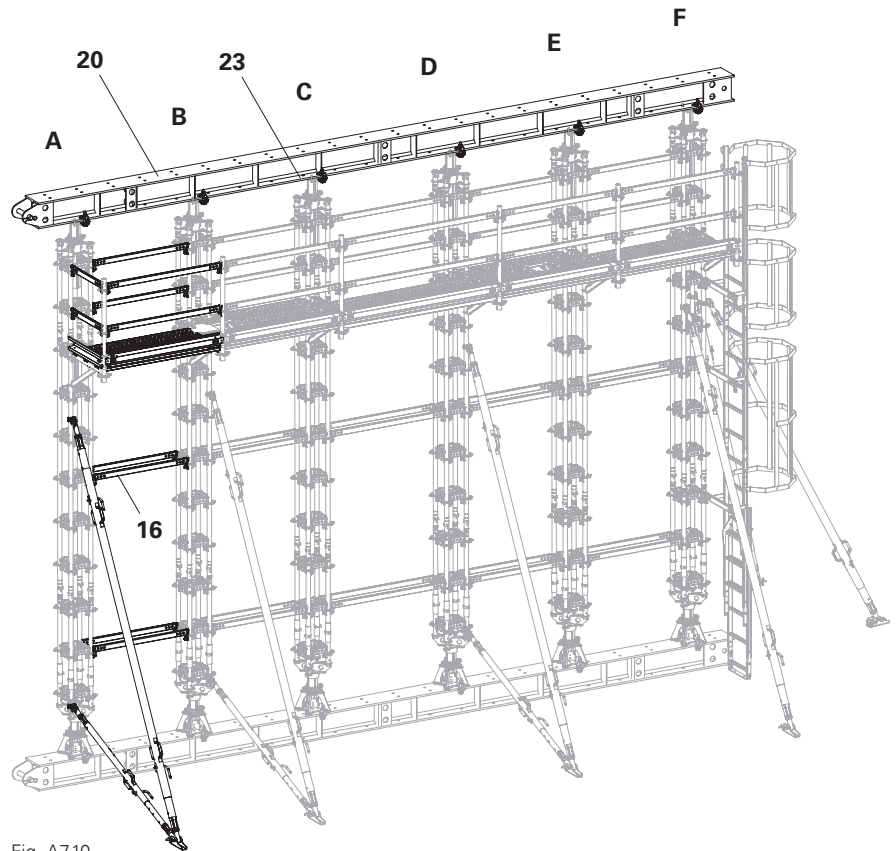

Fig. A7.10

1. Attach Heavy-Duty Props HD around Head Spindle TR (2) with round slings to prevent slipping and take up the load with the lifting device. (Fig. A7.10)
2. Remove the Push-Pull Props HD.
3. Only remove the horizontal ledgers (16) to which the heavy-duty prop being removed is directly connected.
4. Dismantle the work platform, ensuring that there is front-side protection.

A7 Dismantling the main beam frame vertically

5. Lift the Heavy-Duty Prop HD and set it down. (Fig. A7.11)
6. Remove both girder clamps (**23**) from the lower Main Beam HDT (**20**).
7. Remove each lowering jack.
8. Remove the other heavy-duty props in the same way.



The dismantling of the Heavy-Duty Props HD is described in Section A4 "Horizontal Dismantling".

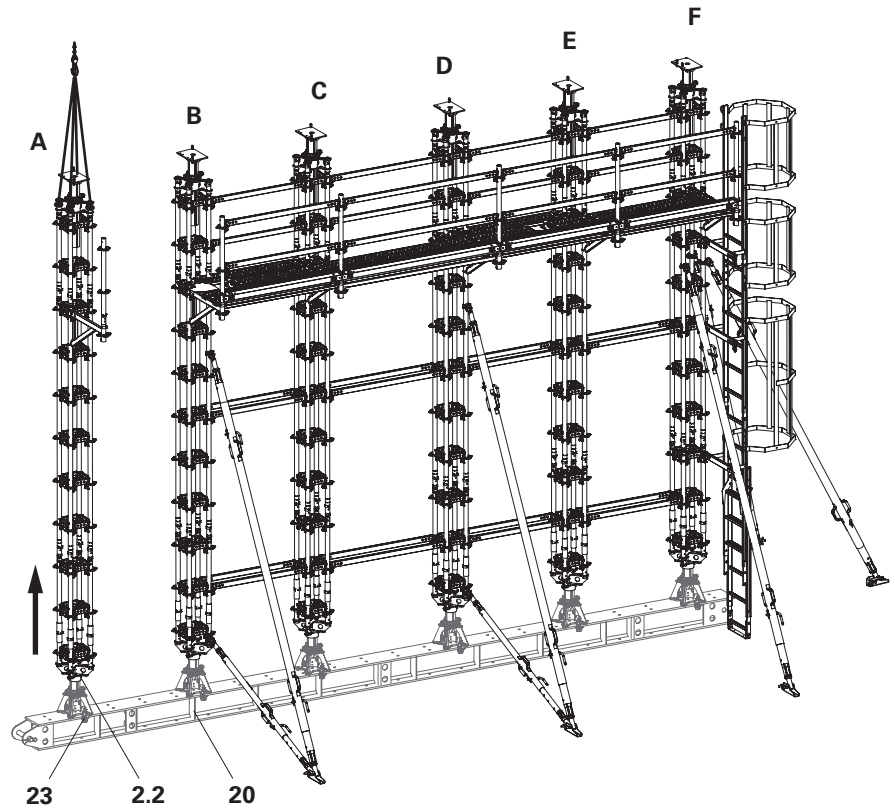

Fig. A7.11

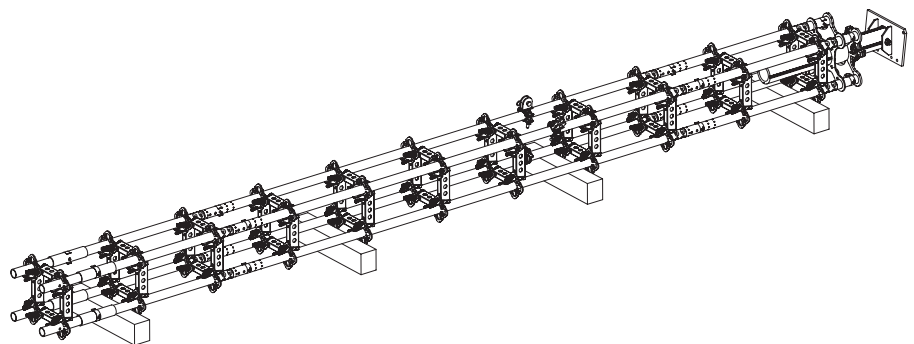

Fig. A7.11a

Load transfer



Always transfer loads centrally to the main beam!

Fit the centring rails (**24**) between the Main Beams HDT (**20**) and the cross girders (**22**). (Fig. B1.01a - B1.01d)
Check the right angle between the centring rail (**24**) and cross girder (**22**).

Horizontal Loads



- Do not transfer horizontal loads onto the Heavy-Duty Props HD! Transfer the loads from top girder level directly to suitable structural components!
- The girder clamps (**23a + 23b**) are positional restraints for the cross girder.
- Do not clamp the upper main beam flanges and lower cross girder flanges together with girder clamps (**23a + 23b**). Only ever fit clamps next to them!

(Fig. B1.01a - B1.02a)

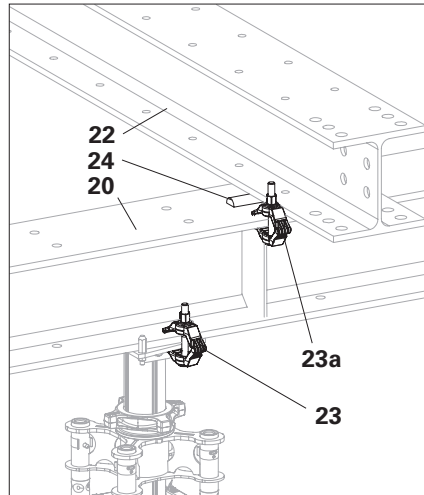

Fig. B1.01a

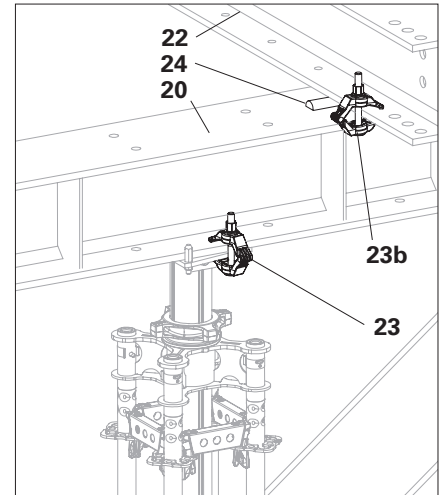

Fig. B1.01b

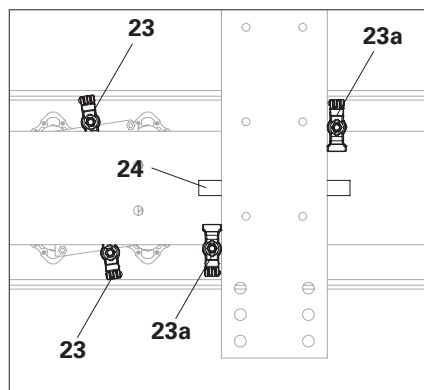

Fig. B1.01c

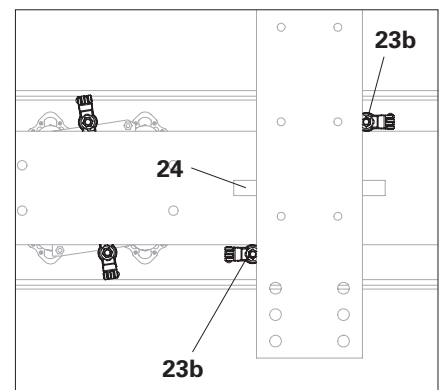

Fig. B1.01d

General information

Bracing consisting of Tie Rods DW 15 (51) is used to transfer horizontal loads to main beam frames and to stabilise Heavy-Duty Props HD.

Horizontal loads from cross girders

Transfer horizontal loads by means of friction and girder clamps (23a + 23b) onto the top beam.

Horizontal loads at the level of the main beam frame

Transfer horizontal loads from the main beam to the base beam via diagonal bracing (55) consisting of DW 15 Tie Rods (if necessary DW 20).

From here, transfer the load into the substrate via friction or built-in parts and foundations. (Fig. B1.02)

Installation of Girder Clamps

For transferring horizontal loads:

- Longitudinally to the Main Beam HDT (20).
 - Girder clamp (23a).
- Laterally to the Main Beam HDT.
 - Girder clamp (23b).

(Fig. B1.01a - B1.02a)

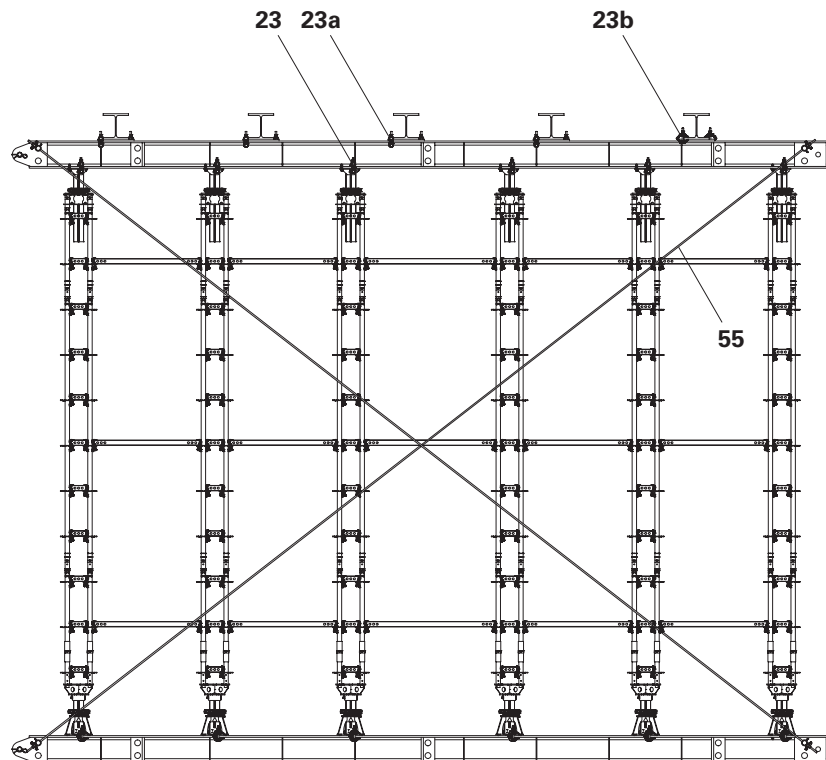

Fig. B1.02

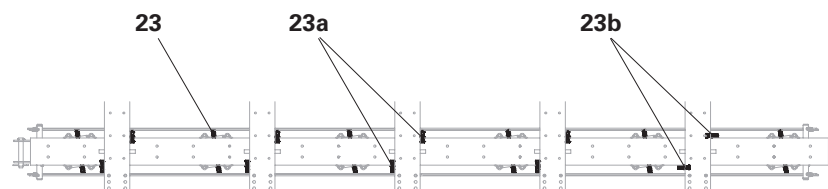

Fig. B1.02a

B1 Loads and bracing

Forces perpendicular to the level of the main beam frame are transferred directly from the Main Beam HDT (20) onto existing components, e.g. abutments. (Fig. B1.04)



Tipping risk!
Push-Pull Props do not carry horizontal loads! They are only assembly aids!



Built-in parts must be planned during the production of the abutment.

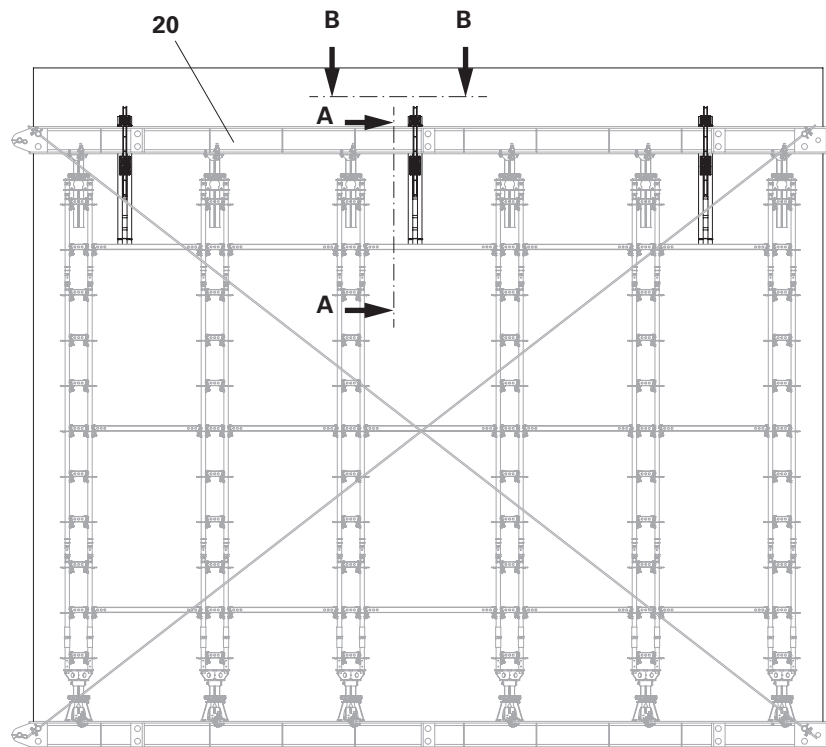

Fig. B1.03

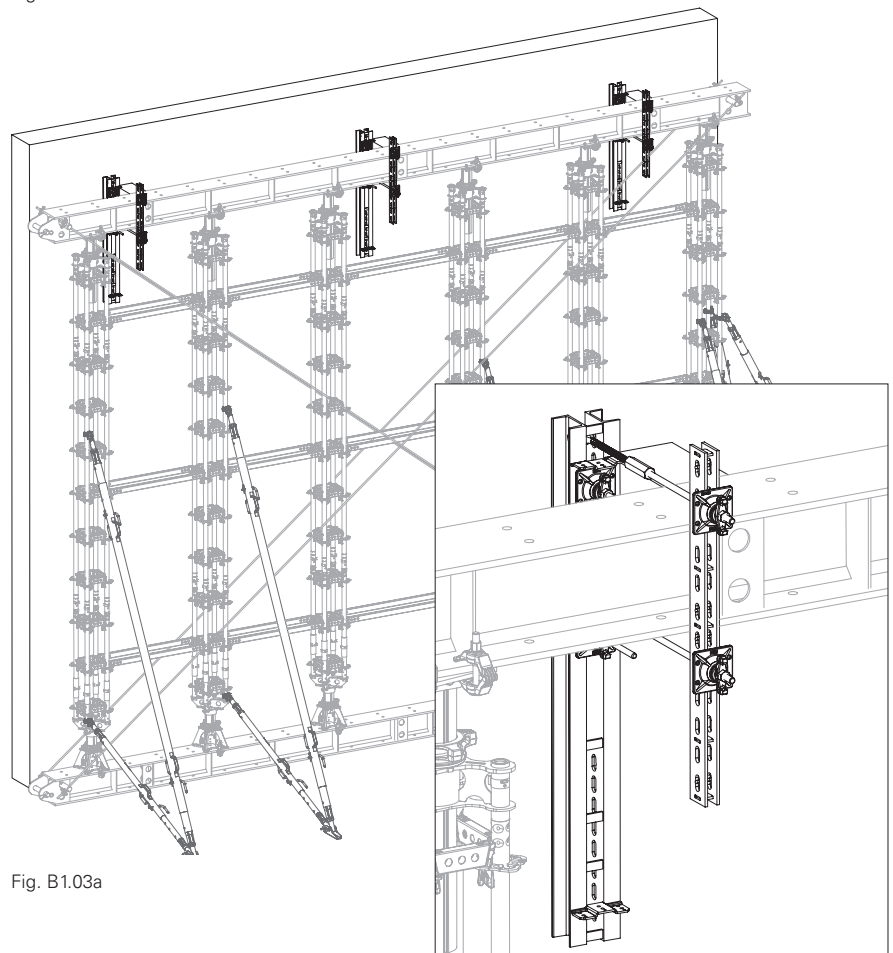

Fig. B1.03a

Examples

Tensile and compression-proof connection

According to structural analysis with Tie Rods DW 15 and, for example, Anchor Sleeve M24 (variant A) or via existing tie holes (variant B).

Components

- 60** Steel Waler SRZ U100
- 61** Column Tie Yoke DW 15
- 62** Hex Nut DW 15 AF 30/108
- 63** Tie Rod DW 15
- 64** Coupling VKZ 99
- 65** Wingnut Pivot Plate DW 15
- 66** Squared timber (on site)
- 67** Nut M20-8, galv.
- 68** Bolt M20 x 100-8.8, galv.
- 69** Anchor Sleeve DW 15

Fixing to an existing structure

See Fig. B1.03 - B1.05.

Variant A

With anchor sleeve set in concrete (**69**)

Variant B

With tie rod (**63**) through existing tie point.

Section A-A

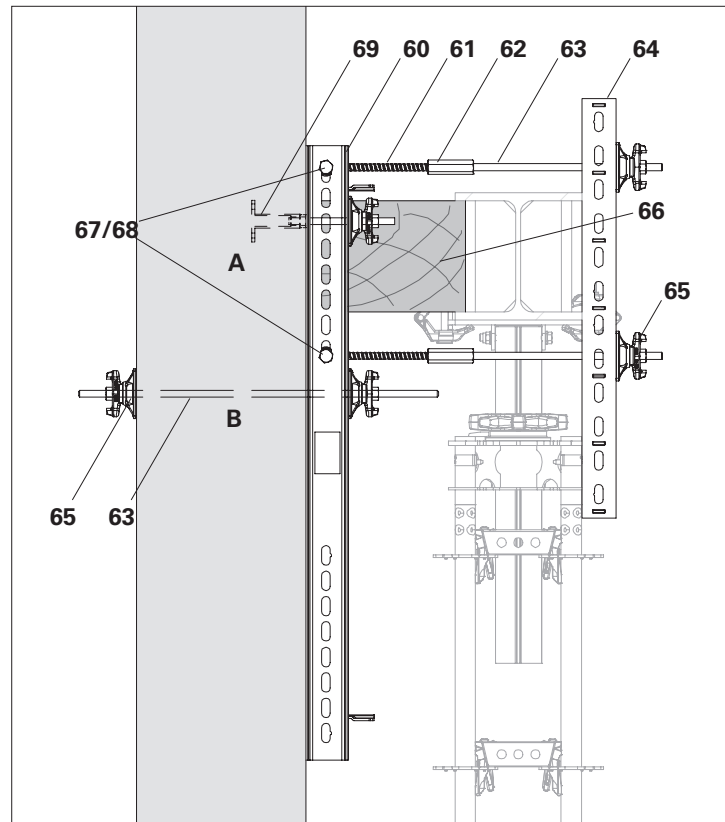

Fig. B1.04

Section B-B

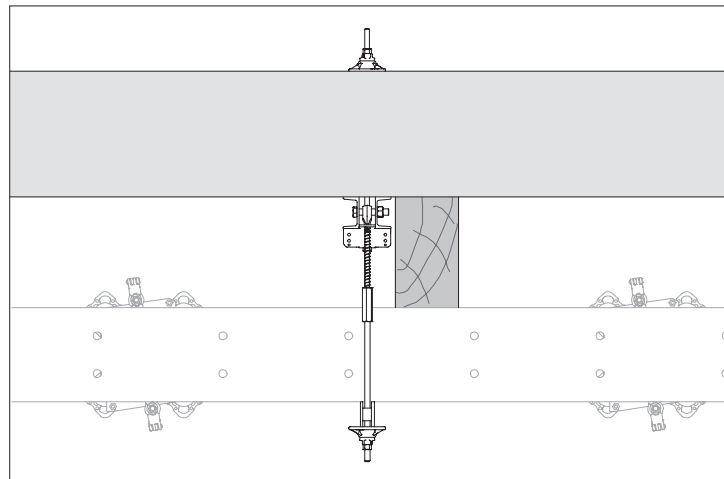

Fig. B1.05

Free-standing Main Beam Frames

1. Assemble free-standing main beam frames as described in Section A6.
2. Horizontal forces at the level of the main beam frame are transferred via diagonal bracing. (See Section A6)
3. Horizontal forces lateral to the main beam frame are transferred via push-pull props (**12**) that are fixed to auxiliary foundations by means of a Connection Plate AV (**17**) on the Main Beam HDT (**20**) and Base Plate-2 RS 210-1400 (**14**). (Fig. B2.01a - B2.01c)
4. For permissible forces, see tables below.
5. Install push-pull prop at $\alpha = 60^\circ$.
6. Secure Connection Plate AV (**17**) against slipping.
7. Fasten the Connection Plate AV on the bottom chord of the Main Beam HDT (**20.1**) by means of bolts and nuts M24 (**18 + 19**).
8. In addition, place one girder clamp (**23**) to the right and one to the left of the Connection Plate AV (**17**). (Fig. B2.01b)
9. Arrangement and installation of the girder clamp according to the approval.

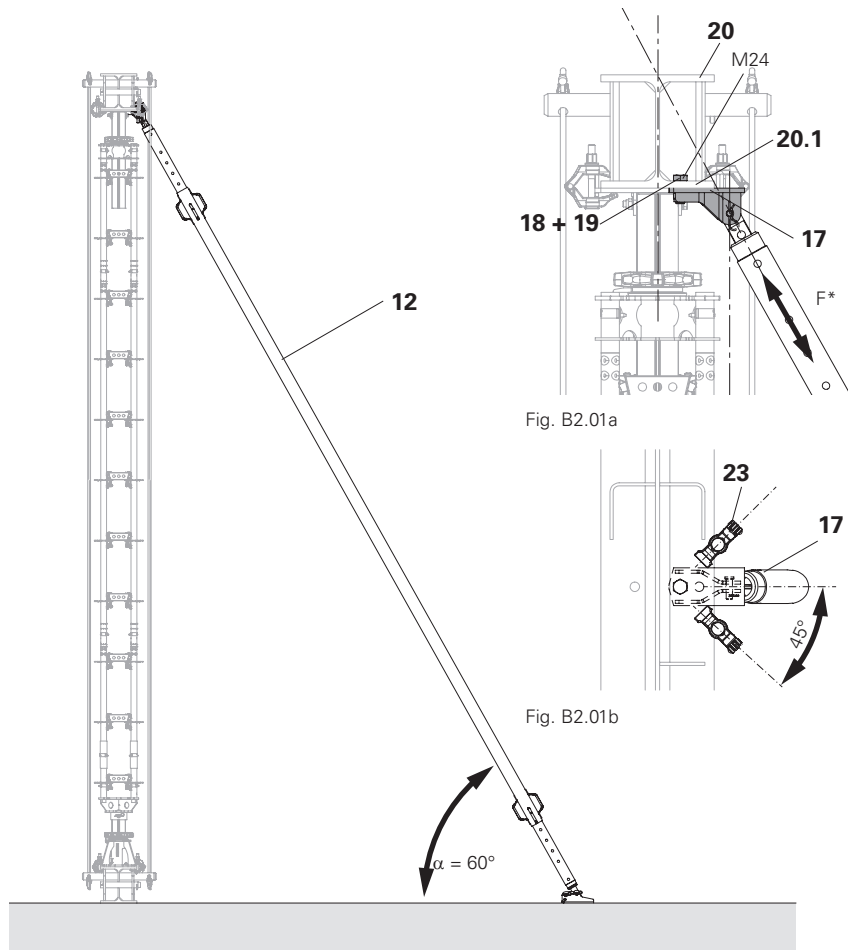

Fig. B2.01

Permissible force to be absorbed by Connection Plate AV at $\alpha = 60^\circ$

Perm. compressive force		Perm. tensile force	
F*	perm. horizontal component	F*	perm. horizontal component
[kN]	[kN]	[kN]	[kN]
70.8	35.4	24.7	12.4

The sum of the push-pull prop forces per main beam frame must not exceed the sum of all permissible push-pull prop loads of the main beam frame.

Permissible force to be carried by Base Plate-2 RS 210-1400 for $\alpha = 60^\circ$ (Fig. B2.01c)

Perm. compressive force		Perm. tensile force	
F*	result. dowel force	F*	result. dowel force
[kN]	[kN]	[kN]	[kN]
25.1	12.5	16.9	23.7

*F = push-pull prop load



The permissible load of the respective Push-Pull Prop must be considered separately.

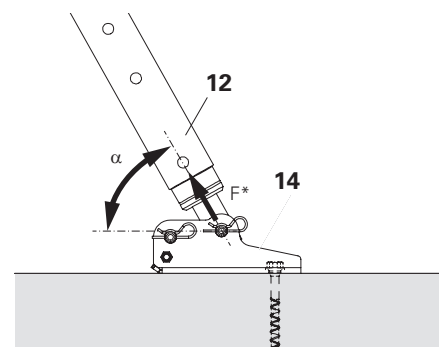

Fig. B2.01c

Individual props without main beam



- Appropriately secure Heavy-Duty Props HD (**10**) at top and bottom against lateral movement.
- Secure free-standing individual props against toppling, for example in the longitudinal direction with Horizontal Ledgers UH-2 (**16**) and in the transverse direction with Push-Pull Props RS.

Main beam frames without lower Main Beam HDT

- Forces from the diagonal strut (**51**) must be transferred directly into the foundations, e.g. via the anchoring system of the PERI Brace Frame.
- The base plates of the Lowering Jack HD (**1**) must rest fully faced on the foundations. (Fig. B2.02)

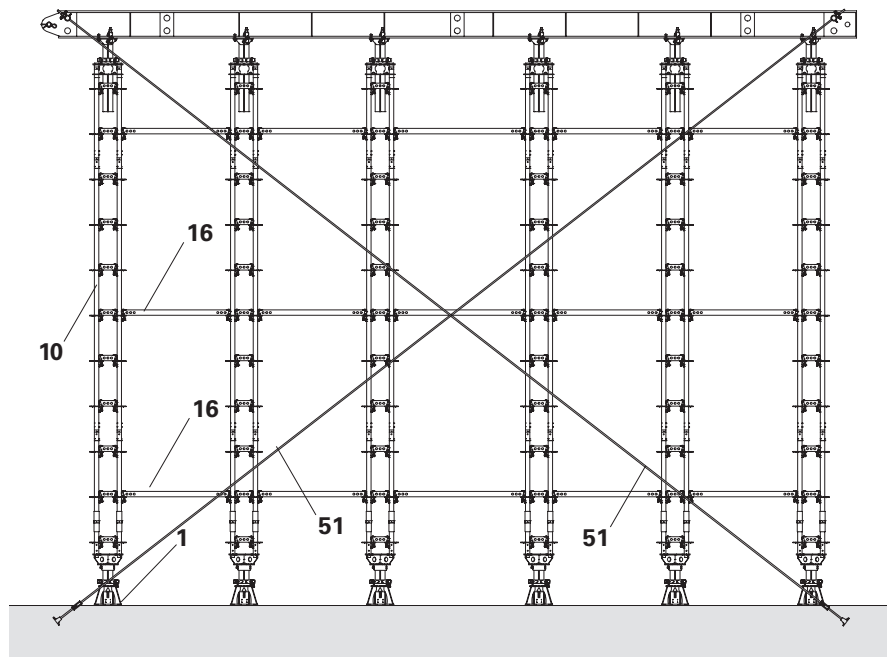
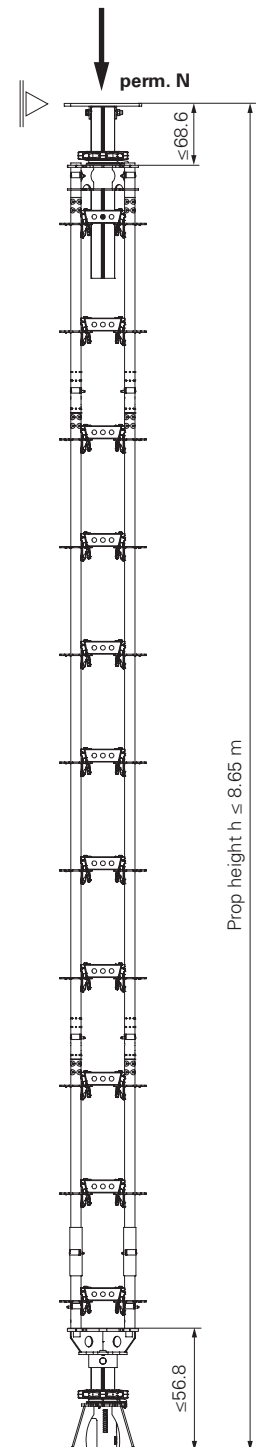

Fig. B2.02



- The values shown in the following tables only apply to configurations compiled according to Section "B4 Materials list" on page 64.
- For props with a structure height $h > 6$ m, the Standard UVR-2 300 must be installed centrally in the leg arrangement.
- When assembling, keep the symmetrical arrangement of the standard joints, see Section "B4 Materials list" on page 64.
- All tables in the PERI Design Tables or in the PERI brochures which are not separately marked feature permissible load-bearing capacities.
- The permissible load-bearing capacities can also be converted into a structural design value of the resistance R_d for the method with partial safety factors after multiplication by $\gamma_F = 1.5$.
- Intermediate values as a result of other wind loads may be determined by linear interpolation between the load-bearing capacities.



Individual props with Standards UVR/UVR-2 and Horizontal Ledgers UH-Plus/UH-2 [in kN]						
		with $q = 0.00$ kN/m ²	with $q = 0.20$ kN/m ²	with $q = 0.50$ kN/m ²	with $q = 0.90$ kN/m ²	with $q = 1.30$ kN/m ²
		perm. N	perm. N	perm. N	perm. N	perm. N
Prop height (cm)	365	201.3	200.8	199.9	198.8	197.6
	465	199.7	198.4	196.2	192.0	187.2
	565	176.1	173.2	168.8	163.5	158.3
	665	167.8	164.1	159.3	153.2	146.5
	765	155.6	151.2	144.8	136.7	129.3
	865	143.7	138.5	130.9	121.1	112.3

B3 Load-bearing capacities



- The same conditions apply as for individual supports on previous page.
- In addition, the load transfer of the Main Beam HDT as base and top beams must be verified on a project-specific basis in each case.
- The specified prop loads and prop heights also apply to the Lowering Jack HD when fully extended.

Main beam frame with Standards UVR/UVR-2 and Horizontal Ledgers UH-Plus/UH-2 [in kN]						
		with q = 0.00 kN/m ²	with q = 0.20 kN/m ²	with q = 0.50 kN/m ²	with q = 0.90 kN/m ²	with q = 1.30 kN/m ²
		perm. N	perm. N	perm. N	perm. N	perm. N
Prop height [cm]	365	173.4	172.7	171.1	168.6	166.5
	465	167.6	166.4	164.2	161.4	158.6
	565	157.7	155.3	150.8	145.9	140.9
	665	146.0	142.6	138.0	131.8	125.8
	765	138.0	134.4	128.3	120.7	113.3
	865	128.4	123.6	117.1	107.0	86.5

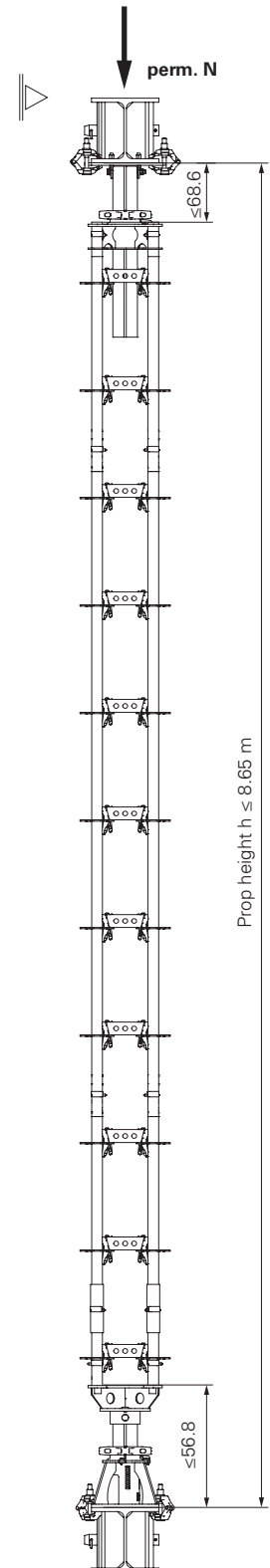

Prop heights with Material List as individual prop

Prop height [m]		Base Stand- ard UVB 25	Standards UVR-2					Ledger UH-2 25	Locking pin D 48/57
min.	max.		50	100	150	200	300		
1.58	2.13	4	4					8	12
2.08	2.63	4		4				12	12
2.58	3.13	4			4			16	12
3.08	3.63	4				4		20	12
3.58	4.13	4		4	4			24	16
4.08	4.63	4		4		4		28	16
4.58	5.13	4			4	4		32	16
5.08	5.63	4				8		36	16
5.58	6.13	4			4		4	40	16
6.08	6.63	4		8			4	44	20
6.58	7.13	4		4	4		4	48	20
7.08	7.63	4			8		4	52	20
7.58	8.13	4			4	4	4	56	20
8.08	8.63	4				8	4	60	20



- The prop heights stated relate to the settings for the Lowering Jack HD at slot 9. If the Lowering Jack HD is set to slot 3 in order to pretension the component, reduce the specified height values by 6 cm.
- For props with a structure height $h > 6$ m, the Standard UVR-2 300 must be installed centrally in the prop arrangement due to the static deformation figure.
- When assembling, keep the symmetrical arrangement of the standard joints.

	Head Spindle TR 110	Lowering Jack HD	Connection Plate UJC	Weight [kg]
	1	1	1	91.03
	1	1	1	104.11
	1	1	1	117.11
	1	1	1	130.15
	1	1	1	146.02
	1	1	1	159.06
	1	1	1	172.06
	1	1	1	185.10
	1	1	1	197.98
	1	1	1	213.90
	1	1	1	226.90
	1	1	1	239.90
	1	1	1	252.94
	1	1	1	265.98



- Refer to the user information for PERI pallets and stacking devices!
- Transportation units must be correctly stacked and secured!

Storage

PERI pallets are suitable for lifting by crane and forklift.

When using a crane, 4-sling lifting gear is used to move the pallets.

During forklift operations, the pallets can be moved either by a forklift truck or by using the pallet lifting truck.

All pallets can be picked up from the long side as well as from the front side.

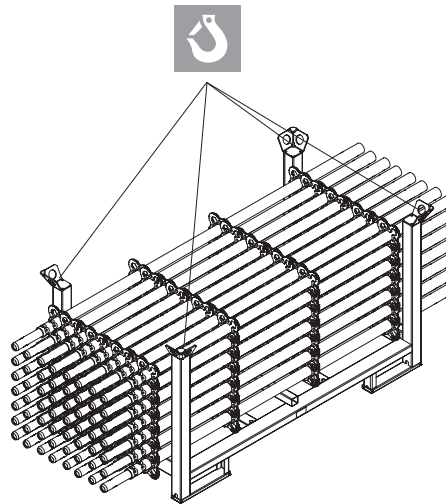

Fig. C1.01

Transportation



- Ensure loads are correctly secured during transport!
- Use tension belts or steel straps!
- Observe national transport regulations!

Hydraulic Unit HD

When transporting or placing in storage, the hydraulic components - hose, cylinder and hand pump - must be separately stored and transported in the designated aluminium case.

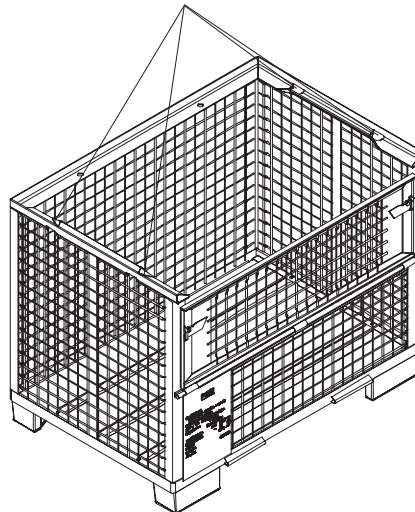

Fig. C1.02

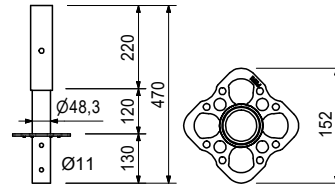
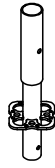

Fig. C1.03

PERI UP Flex Heavy-Duty Prop HD

Art. no.	Weight [kg]	
133499	2.260	Base Standard UVB 25

For assembling directly onto the base spindles.
Can also be used as 25 cm standard.



Art. no.	Weight [kg]	
400014	2.470	Base Standard UVB 24

For assembling directly onto the base spindles.

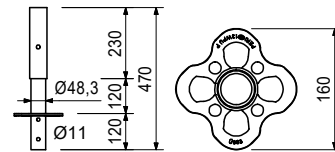
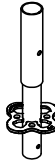

Art. no.	Weight [kg]		L [mm]
		Standards UVR-2	
132219	2.490	Standard UVR-2 50	500
132224	4.340	Standard UVR-2 100	1000
132229	6.190	Standard UVR-2 150	1500
132234	8.030	Standard UVR-2 200	2000
132239	11.700	Standard UVR-2 300	3000

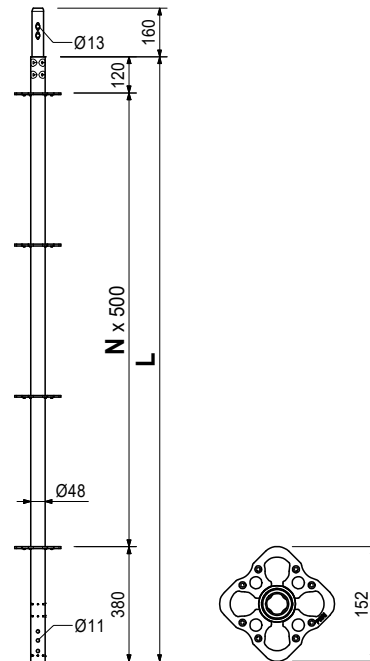
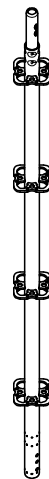

PERI UP Flex Heavy-Duty Prop HD

Art. no.	Weight [kg]		L [mm]
		Standards UVR	
402859	3.080	Standard UVR 50	500
401306	5.380	Standard UVR 100	1000
402860	7.690	Standard UVR 150	1500
400009	9.990	Standard UVR 200	2000
400012	14.700	Standard UVR 300	3000
400013	19.200	Standard UVR 400	4000

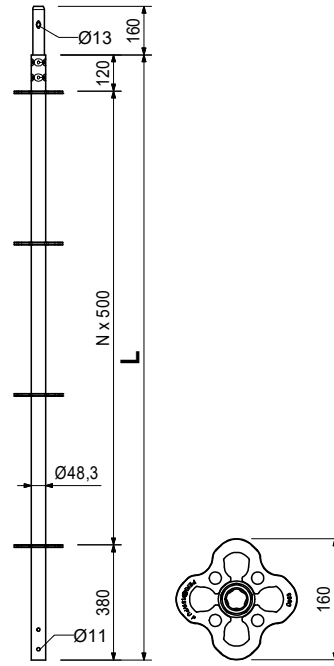

PERI UP Flex Heavy-Duty Prop HD

Art. no.	Weight [kg]		L [mm]	X [mm]
		Horizontal Ledger UH-2		
131995	1.400	Horizontal Ledger UH-2 25	204	250
133900	1.590	Horizontal Ledger UH-2 33	284	330
131998	2.030	Horizontal Ledger UH-2 50	454	500
133903	2.470	Horizontal Ledger UH-2 67	624	670
132213	2.680	Horizontal Ledger UH-2 75	704	750
132004	3.730	Horizontal Ledger UH-2 100	954	1000
132007	4.500	Horizontal Ledger UH-2 125	1204	1250
132010	4.670	Horizontal Ledger UH-2 150	1454	1500
132013	5.330	Horizontal Ledger UH-2 175	1704	1750
132016	5.990	Horizontal Ledger UH-2 200	1954	2000
132019	6.650	Horizontal Ledger UH-2 225	2204	2250
132025	7.310	Horizontal Ledger UH-2 250	2454	2500
132022	8.640	Horizontal Ledger UH-2 300	2954	3000

Note

With colour-coded length marking.

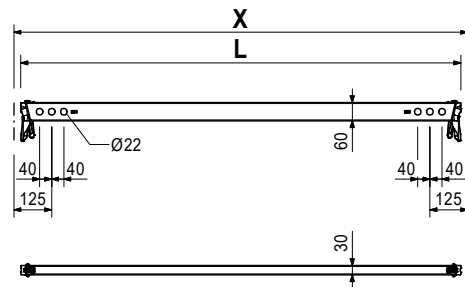
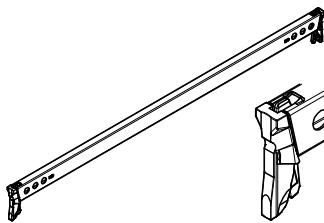

Art. no.	Weight [kg]		L [mm]	X [mm]
		Horizontal Ledger UH Plus		
414613	1.430	Horizontal Ledger UH 25 Plus	204	250
414595	2.080	Horizontal Ledger UH 50 Plus	454	500
429982	2.520	Horizontal Ledger UH 67 Plus	624	670
414629	2.740	Horizontal Ledger UH 75 Plus	704	750
414632	4.470	Horizontal Ledger UH 100 Plus	954	1000
414638	5.440	Horizontal Ledger UH 125 Plus	1204	1250
414641	4.720	Horizontal Ledger UH 150 Plus	1454	1500
417032	5.390	Horizontal Ledger UH 175 Plus	1704	1750
414645	6.050	Horizontal Ledger UH 200 Plus	1954	2000
416356	6.710	Horizontal Ledger UH 225 Plus	2204	2250
414648	7.370	Horizontal Ledger UH 250 Plus	2454	2500
414651	8.690	Horizontal Ledger UH 300 Plus	2954	3000

Note

With length marking for easier identification.

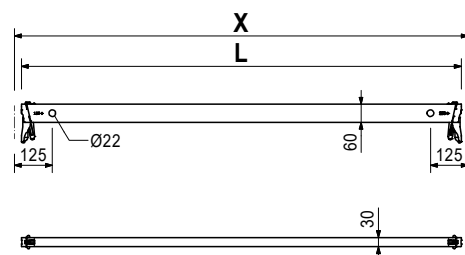
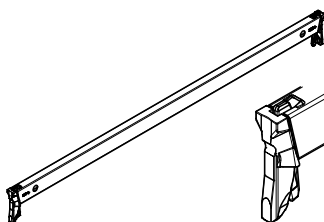

PERI UP Flex Heavy-Duty Prop HD

Art. no.	Weight [kg]	
111053	0.059	Locking Pin Ø48/Ø57

As tension-proof connection of standards with a diameter of 48 up to 57 mm.

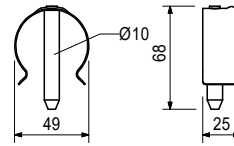

Art. no.	Weight [kg]	
100719	0.060	Bolt ISO 4014 M10 x 070-8.8, galv.

As tension-proof connection of verticals at suspended scaffolds and formwork girders.

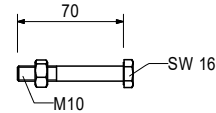
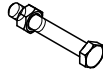

Art. no.	Weight [kg]	
126435	25.900	Head Spindle TR 110 - 80/55

Head spindle for PERI UP Heavy-Duty Prop. Can be tilted up to 3° along one axis.

Note

Loads > 50 kN are to be released with hydraulics.

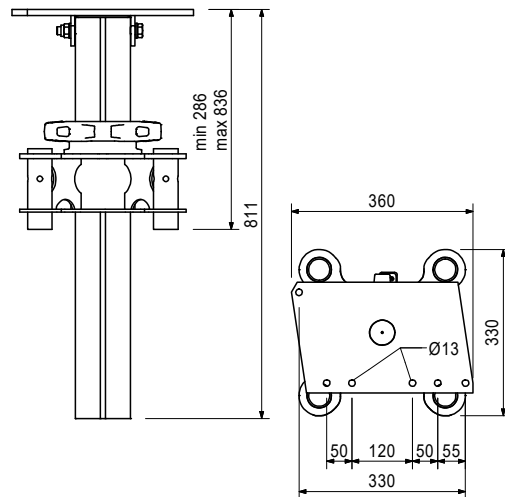
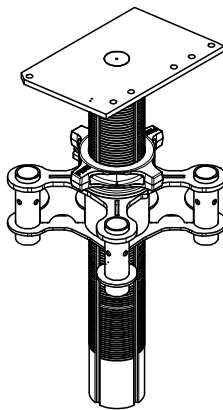

Accessories (not included)

022027	3.600	Wingnut Spanner HD
--------	-------	---------------------------

Art. no.	Weight [kg]	
022027	3.600	Wingnut Spanner HD

For easy removal of Head Spindle HDK 45, Head Spindle TR 110 - 80/55 and the MULTIPROP Slab Prop.

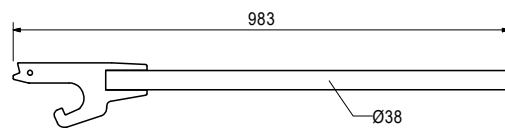
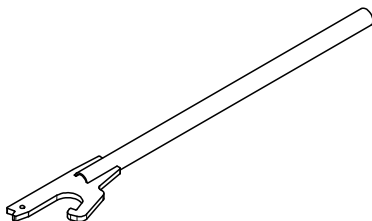

PERI UP Flex Heavy-Duty Prop HD

Art. no.	Weight [kg]	
126436	21.500	Lowering Jack HD

For releasing high loads up to 200 kN and displacement-controlled lowering as well as for systematic prestressing of supports.

Note

Loads >50 kN are to be released with hydraulics.

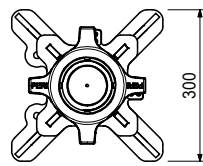
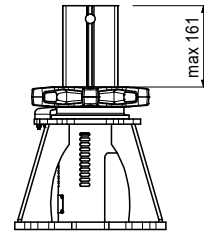
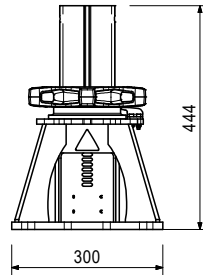
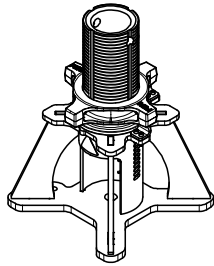

Accessories (not included)

126438	12.900	Hydraulic Unit HD
126437	12.800	Connection Plate UJC

Art. no.	Weight [kg]	
126437	12.800	Connection Plate UJC

For connecting the Standards UVR in a 25 x 25 cm grid. Tilting in any direction by 2°.

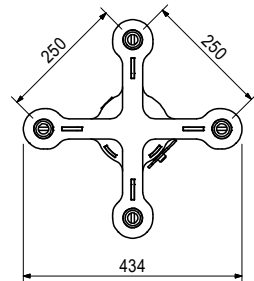
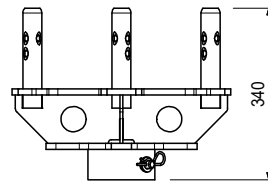
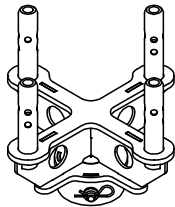

Art. no.	Weight [kg]	
126438	12.900	Hydraulic Unit HD

Permissible load-bearing capacity up to 300 kN (readable directly on the manometer). Cylinder stroke up to 62 mm.

Note

Observe Instructions for Use.

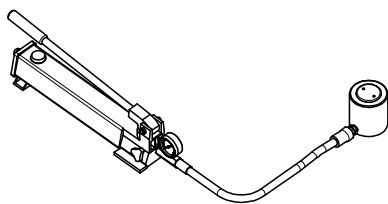

PERI UP Flex Heavy-Duty Prop HD

Art. no.	Weight [kg]	
412678	6.510	Console Bracket UCM 75 with pin

With connection for Console Bracket Brace UCM.

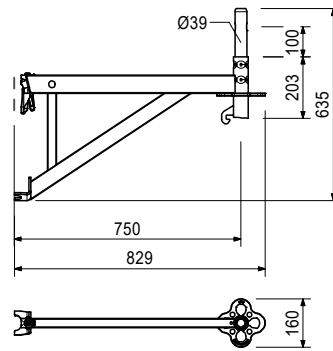
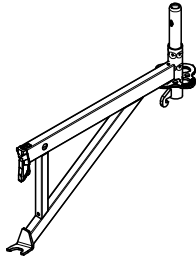

Art. no.	Weight [kg]	
111128	5.710	Console Bracket UCM 75-2

With connection for Console Bracket Brace UCM.

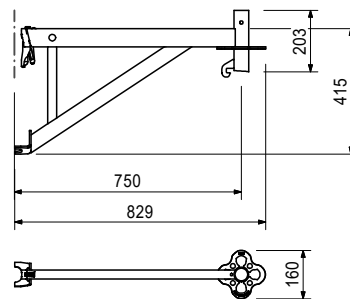
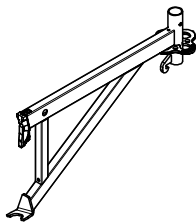

Accessories (not included)

100301	0.969	Connector ULT 32
111053	0.059	Locking Pin Ø48/Ø57

Art. no.	Weight [kg]	
100301	0.969	Connector ULT 32

Single pin for connection of tubes Ø 48.3 x 3.2 mm, e.g. formwork girders or top standards without interlock.

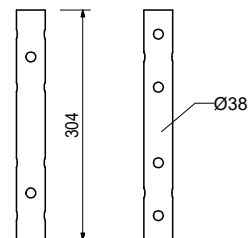

Accessories (not included)

111053	0.059	Locking pin Ø 48/57
100719	0.060	Bolt ISO 4014 M10 x 70-8.8

PERI UP Flex Heavy-Duty Prop HD

Art. no.	Weight [kg]	
022013	0.137	Centring Bolt HD M12, galv.

For the HD 200 system.

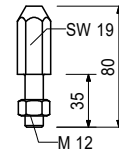

Complete with

1 pc. 710330 nut ISO 4032 M12-8, galv.

Art. no.	Weight [kg]	
022008	1,130.000	Main Beam HDT 880

System steel beam for use with HD 200 main beam frames and special constructions. Profile HEB 300.

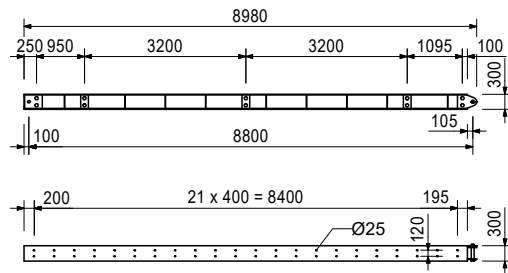
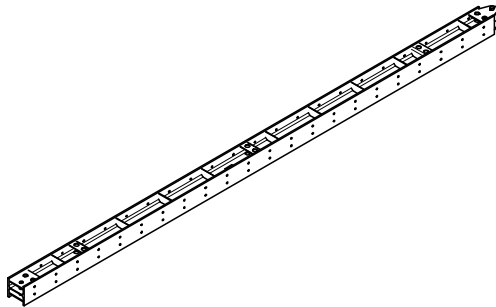

Complete with

1 pc. 105435 bolt \varnothing 50 x 330
 1 pc. 722457 sleeve ISO 8752 10 x 70, galv.
 1 pc. 710618 cotter pin 8/1, galv.

Art. no.	Weight [kg]	
022009	582.000	Main Beam HDT 440

System steel beam for use with HD 200 main beam frames and special constructions. Profile HEB 300.

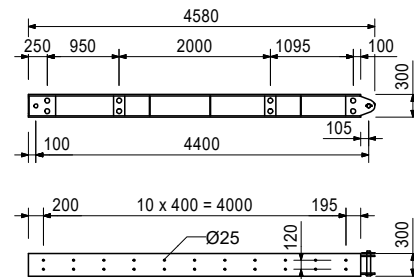
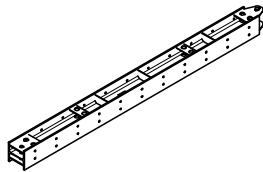

Complete with

1 pc. 105435 bolt \varnothing 50 x 330
 1 pc. 722457 sleeve ISO 8752 10 x 70, galv.
 1 pc. 710618 cotter pin 8/1, galv.

PERI UP Flex Heavy-Duty Prop HD

Art. no.	Weight [kg]	
022010	379.000	Main Beam HDT 280

System steel beam for use with HD 200 main beam frames and special constructions. Profile HEB 300.

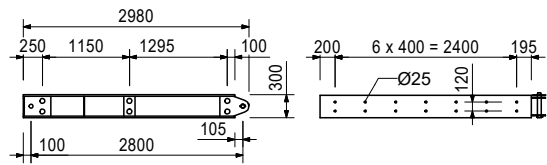
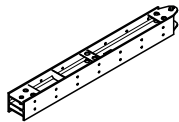

Complete with

- 1 pc. 105435 bolt $\varnothing 50 \times 330$
- 1 pc. 722457 sleeve ISO 8752 10 x 70, galv.
- 1 pc. 710618 cotter pin 8/1, galv.

Art. no.	Weight [kg]	
051460	2.180	Ladder Base, galv.

As bottom ladder connector and for securing ladders against sliding on the scaffold decks.

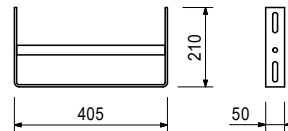
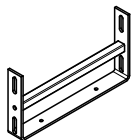

Art. no.	Weight [kg]	
103718	0.684	Ladder Hook, galv.

For adjusting the bottom ladder. Always use in pairs.

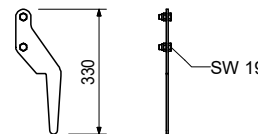

Complete with

- 2 pcs. 710266 bolt ISO 4017 M12 x 25–8.8, galv.
- 2 pcs. 710381 nut ISO 7040 M12–8, galv.

Art. no.	Weight [kg]	
		Ladder Cage, galv.
104132	15.600	Ladder Cage 75
051450	25.200	Ladder Cage 150

Ladder cage for PERI ladder access.

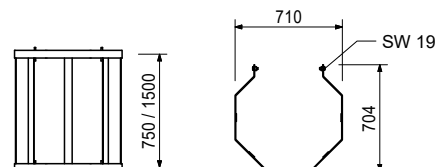
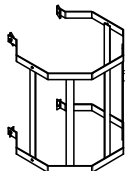

Complete with

- 4 pcs. 710266 bolt ISO 4017 M12 x 25–8.8, galv.
- 4 pcs. 701763 clamping plate FI 25 x 10 x 90

PERI UP Flex Heavy-Duty Prop HD

Art. no.	Weight [kg]	
124813	4.000	Ladder Connector UAC-2

Note

Connects Ladder 180/6 (article no. 051410) with PERI UP Standards.

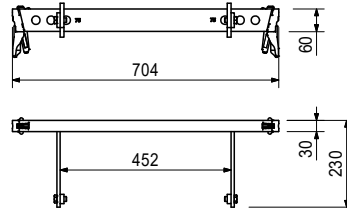
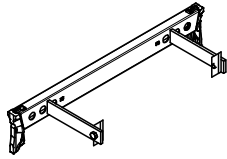

Accessories (not included)

051410	11.700	Ladder 180/6, galv.
051460	2.180	Ladder Base, galv.
103724	10.400	Access Ladder 180/2, galv.
104132	15.600	Ladder Cage 75
051450	25.200	Ladder Cage 150

Complete with

1 pc. 051410 ladder 180/6, galv.

Art. no.	Weight [kg]	
051410	11.700	Ladder 180/6, galv.

For accessing PERI formwork systems.

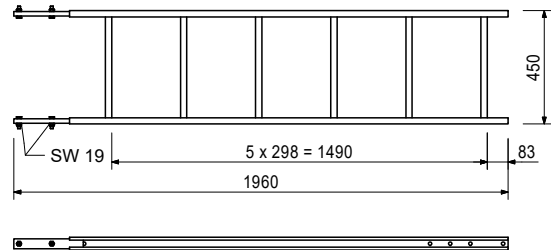
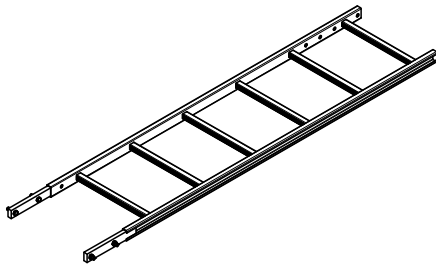

Complete with

4 pcs. 710224 bolt ISO 4017 M12 x 40-8.8, galv.
4 pcs. 710381 nut ISO 7040 M12-8, galv.

Art. no.	Weight [kg]	
103724	10.400	Access Ladder 180/2, galv.

For accessing PERI formwork systems.

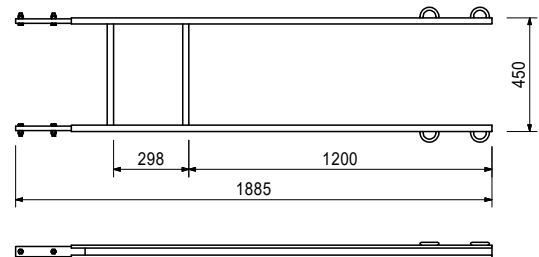
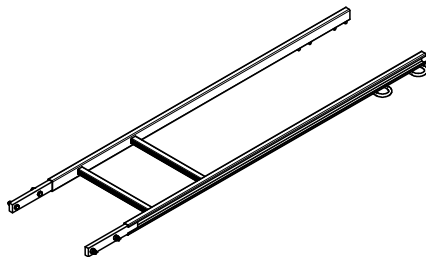

Complete with

4 pcs. 710224 bolt ISO 4017 M12 x 40-8.8, galv.
4 pcs. 710381 nut ISO 7040 M12-8, galv.

PERI UP Flex Heavy-Duty Prop HD

Art. no.	Weight [kg]	
131723	1.440	Brace Connector HDR-2

For connecting push-pull props and kicker braces to components with Ø 48 mm.

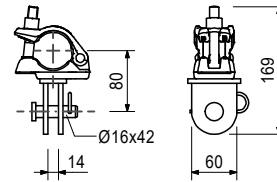
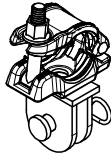

Complete with

- 1 pc. 027170 bolt Ø 16 x 42, galv.
- 1 pc. 018060 cotter pin 4/1, galv.

Art. no.	Weight [kg]	
028080	2.960	Connection Plate AV/Push-Pull Prop

For connecting push-pull props and kicker braces to the Main Beam HDT.

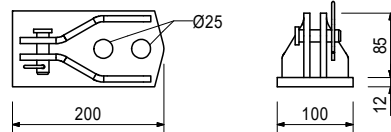
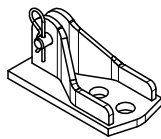

Complete with

- 1 pc. 027170 bolt Ø 16 x 42, galv.
- 1 pc. 018060 cotter pin 4/1, galv.

Art. no.	Weight [kg]		X [mm]	perm. p [kN/m ²]
Steel Decks UDG-2				
132479	3.190	Steel Deck UDG-2 25 x 50	500	6
132483	3.960	Steel Deck UDG-2 25 x 67	670	6
132488	4.320	Steel Deck UDG-2 25 x 75	750	6
132492	5.450	Steel Deck UDG-2 25 x 100	1000	6
132502	6.590	Steel Deck UDG-2 25 x 125	1250	6
132505	7.730	Steel Deck UDG-2 25 x 150	1500	6
132508	10.500	Steel Deck UDG-2 25 x 200	2000	6
132511	12.900	Steel Deck UDG-2 25 x 250	2500	4.5
132515	15.800	Steel Deck UDG-2 25 x 300	3000	3

Length X: 500 – 1.500 with H of 45 mm.
 Length X: 2000 – 2.500 with H of 60 mm.
 Length X: 3000 with H of 70 mm.

Note

Values correspond with EN 12811-1.

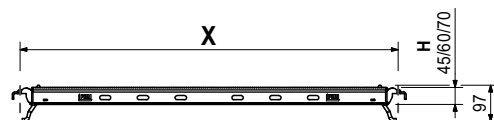
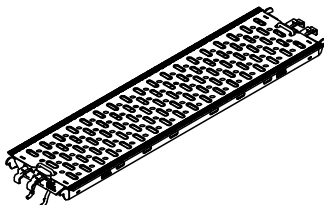

PERI UP Flex Heavy-Duty Prop HD

Art. no.	Weight [kg]		X [mm]	perm. p [kN/m ²]
		Steel Decks UDG 25		
424124	3.810	Steel Deck UDG 25 x 50	500	6
432858	4.810	Steel Deck UDG 25 x 67	670	6
424121	5.180	Steel Deck UDG 25 x 75	750	6
424118	6.550	Steel Deck UDG 25 x 100	1000	6
424115	7.940	Steel Deck UDG 25 x 125	1250	6
424112	9.330	Steel Deck UDG 25 x 150	1500	6
424109	12.200	Steel Deck UDG 25 x 200	2000	6
423771	14.900	Steel Deck UDG 25 x 250	2500	4.5
424915	17.700	Steel Deck UDG 25 x 300	3000	3

Fit onto Horizontal Ledgers UH.

Note

Values correspond with EN 12811-1.

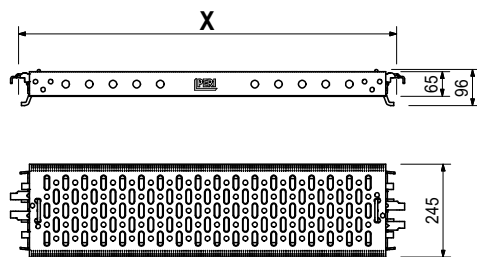
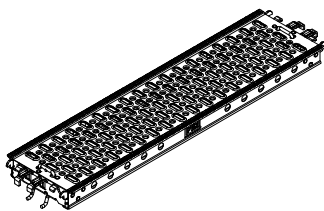

Art. no.	Weight [kg]		L [mm]	X [mm]
		Steel Toe Boards UPY		
132592	0.414	Steel Toe Board UPY 25	236	250
110213	0.929	Steel Toe Board UPY 50	486	500
110514	1.450	Steel Toe Board UPY 75	736	750
110073	1.960	Steel Toe Board UPY 100	986	1000
110160	2.990	Steel Toe Board UPY 150	1486	1500
110176	4.030	Steel Toe Board UPY 200	1986	2000
110208	5.060	Steel Toe Board UPY 250	2486	2500
110211	6.090	Steel Toe Board UPY 300	2986	3000

Note

Default surface: galvanised and painted in yellow.

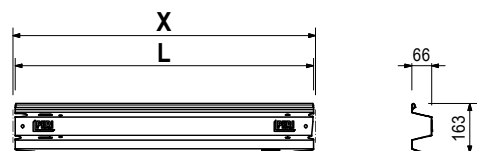
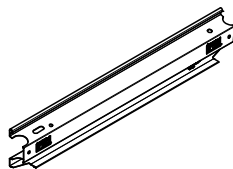

Accessories (not included)

134542	0.606	Toe Board Compensation UPY-L
--------	-------	-------------------------------------

PERI UP Flex Heavy-Duty Prop HD

Art. no.	Weight [kg]	
136582	0.831	Ledger-to-Ledger Coupler UHA-2

For connecting horizontal ledgers at right-angles.

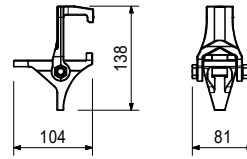
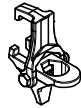

Art. no.	Weight [kg]	
201842	8.640	Tie Rod DW 15 Tie Rod DW 15, L = 6.00 m

Note

Non-weldable! Observe the permissions! Permissible tension force 90 kN.

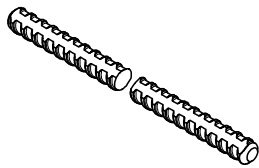

Art. no.	Weight [kg]	
030130	0.318	Cam nut DW 15, galv.

For anchoring with Tie Rod DW 15 and B 15.

Note

Permissible load 90 kN.

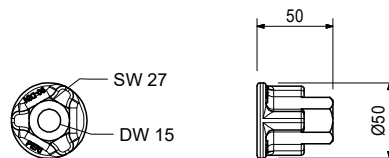
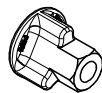

PERI UP Flex Heavy-Duty Prop HD

Art. no.	Weight [kg]	
201022	0.402	Hex. Nut DW 15 AF 30/105, galv.

For coupling Tie Rod DW 15 and B 15.

Note

Permissible load 90 kN.

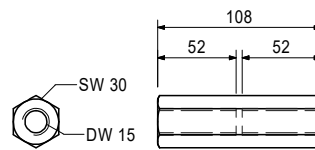
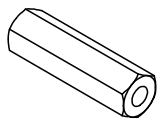

Art. no.	Weight [kg]	
201001	0.439	Wing nut DW 15, galv.

For anchoring with Tie Rod DW 15 and B 15.

Note

Permissible load 90 kN.

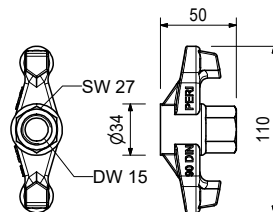
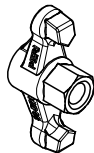

Art. no.	Weight [kg]	
022025	1.970	Centring Rail HD 40 x 20 x 400

For centring cross girders on the Main Beam HDT.

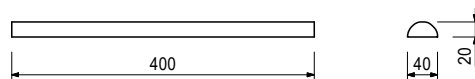
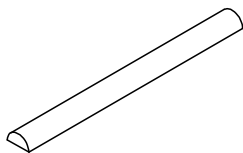

Art. no.	Weight [kg]	
022011	13.200	Double Tie Yoke HDD

For anchoring with Tie Rods DW 15 and DW 20.

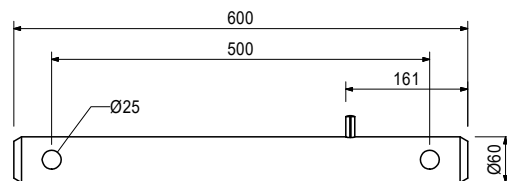
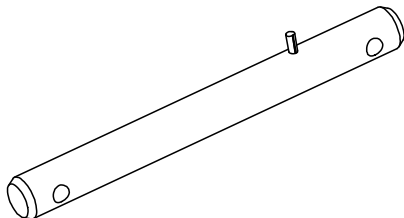

PERI UP Flex Heavy-Duty Prop HD

Art. no.	Weight [kg]	
022021	31.900	Trolley HD

For moving longitudinal beams on the Main Beam HDT.

Note

Permissible load-bearing capacity 2.5 t.

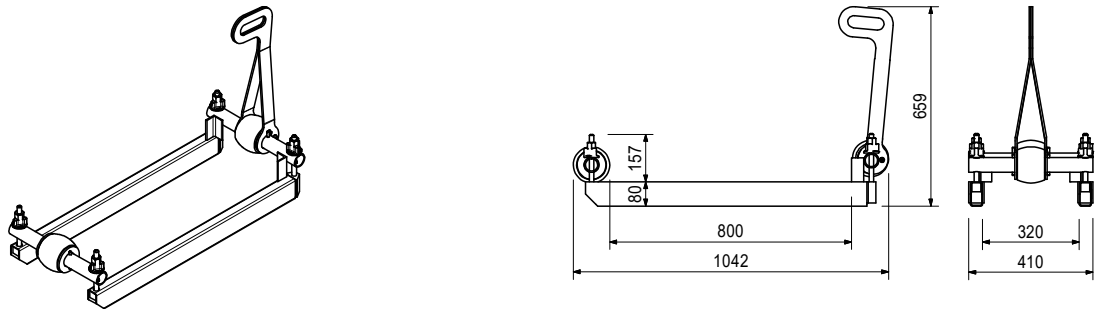

Art. no.	Weight [kg]	
106183	2.200	Girder Clamp HD 70 mm, galv.

For connecting beams running crosswise.

Note

Observe the permissions!
Plan for 2 pieces per Head Spindle!

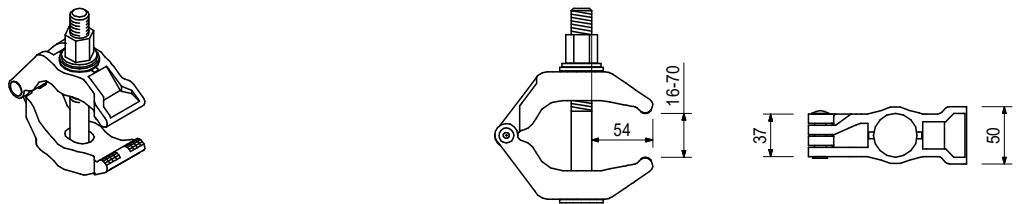

Art. no.	Weight [kg]	
022026	1.780	Flange Clamp IPB 300 - 1000

To create an anti-tilt device.



Art. no.	Weight [kg]	
117466	10.600	Push-pull Prop RS 210, galv.

Extension length L = 1.30 – 2.10 m.
For aligning PERI formwork systems and pre-cast concrete elements.

Note

See PERI Design Tables for permissible load.

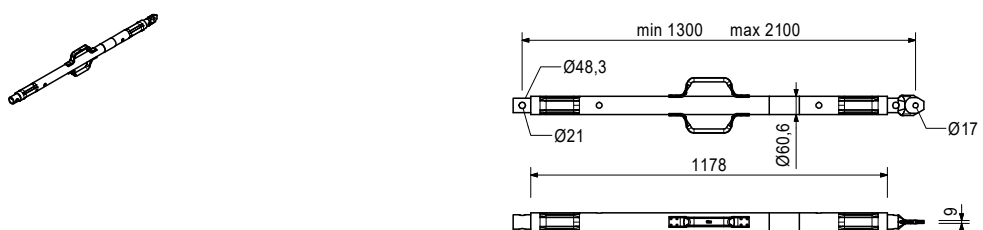

PERI UP Flex Heavy-Duty Prop HD

Art. no.	Weight [kg]	
118238	12.100	Push-pull Prop RS 260, galv.

Extension length L = 2.30 – 2.60 m.
 For aligning PERI formwork systems and pre-cast concrete elements.

Note

See PERI Design Tables for permissible load.

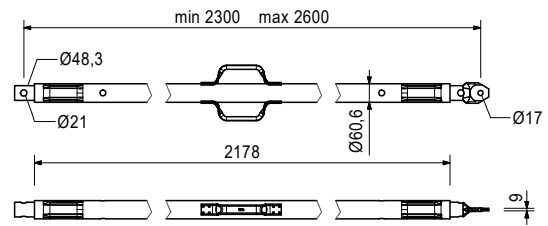
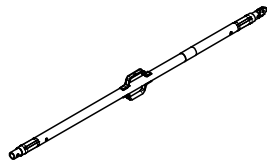

Art. no.	Weight [kg]	
117467	15.500	Push-pull Prop RS 300, galv.

Extension length L = 1.90 – 3.00 m.
 For aligning PERI formwork systems and pre-cast concrete elements.

Note

See PERI Design Tables for permissible load.

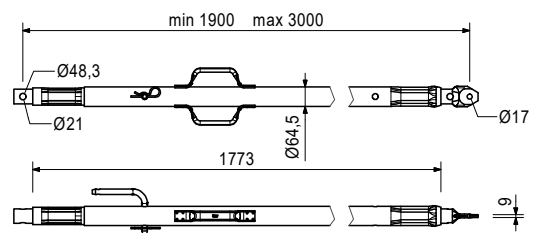
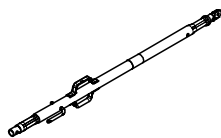

Art. no.	Weight [kg]	
117468	23.000	Push-pull Prop RS 450, galv.

Extension length L = 2.80 – 4.50 m.
 For aligning PERI formwork systems and pre-cast concrete elements.

Note

See PERI Design Tables for permissible load.

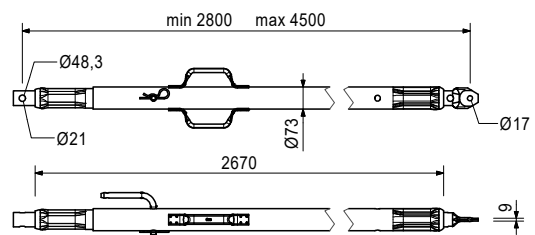
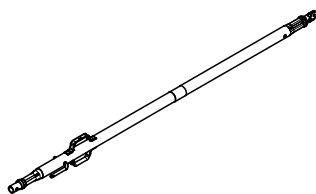

PERI UP Flex Heavy-Duty Prop HD

Art. no.	Weight [kg]	
117469	39.900	Push-pull Prop RS 650, galv.

Extension length L = 4.30 – 6.50 m.
For aligning PERI formwork systems and pre-cast concrete elements.

Note

See PERI Design Tables for permissible load.

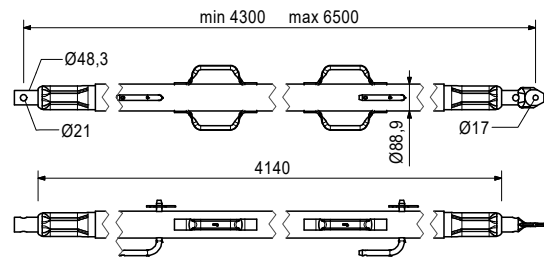
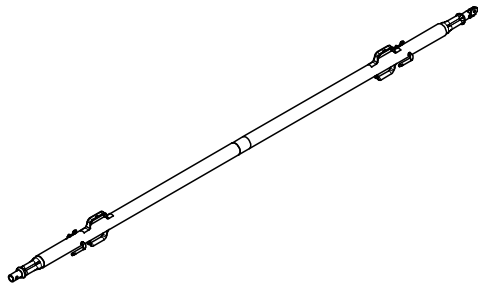

Art. no.	Weight [kg]	
028990	115.000	Push-pull Prop RS 1000, galv.

Extension length L = 6.40 – 10.00 m.
For aligning PERI formwork systems.

Note

See PERI Design Tables for permissible load.

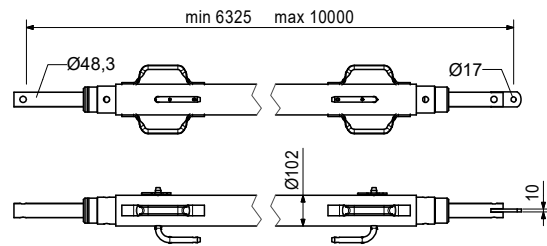
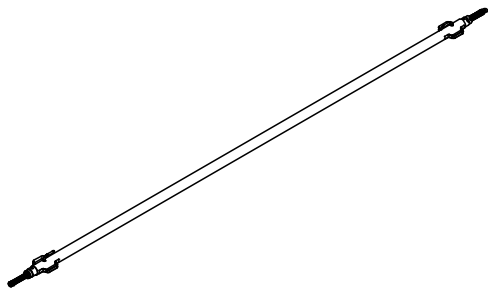

Art. no.	Weight [kg]	
103800	271.000	Push-pull Prop RS 1400, galv.

Extension length L = 6.40 – 14.00 m.
For aligning PERI formwork systems.

Note

See PERI Design Tables for permissible load.
Chain attached/detached from the ground.

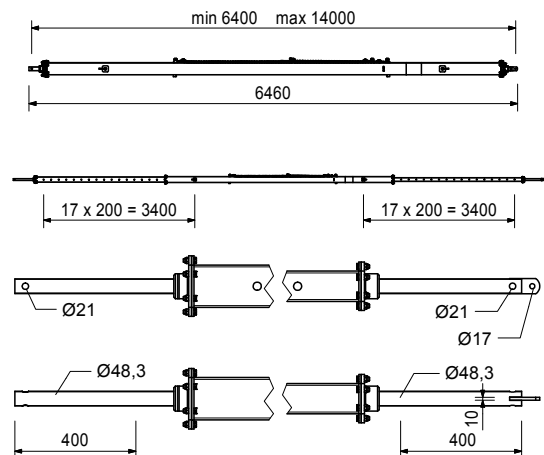
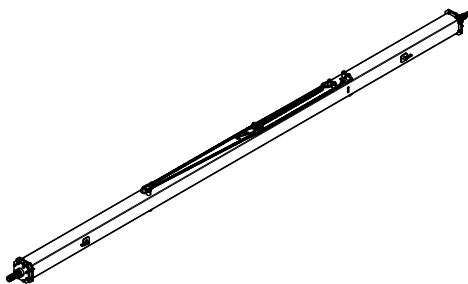

PERI UP Flex Heavy-Duty Prop HD

Art. no.	Weight [kg]	
126666	3.040	Base Plate-3 for RS 210 - 1400

For assembling the RS 210, RS 260, RS 300, RS 450, RS 650, RS 1000 and RS 1400 Push-Pull Props.

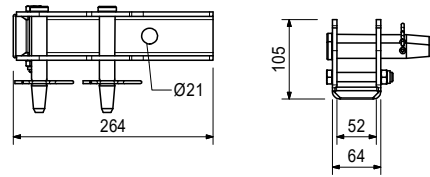
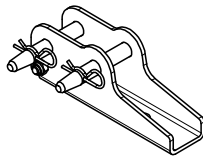

Accessories (not included)

124777	0.210	PERI Anchor Bolt 14/20 x 130
--------	-------	-------------------------------------

Complete with

- 2 pcs. 105400 bolt Ø 20 x 140, galv.
- 2 pcs. 018060 cotter pin 4/1, galv.
- 1 pc. 113063 bolt ISO 4014 M12 x 80-8-8, galv.
- 1 pc. 113064 hex nut ISO 7040-M12-8-G, galv.

Art. no.	Weight [kg]	
102018	4.880	Base Plate-2 for RS 1000/1400, galv.

For fitting the Push-Pull Props RS 210, 260, 300, 450, 650, 1000, 1400 and heavy-duty spindles.

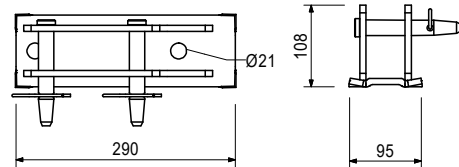
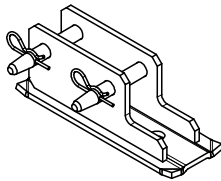

Complete with

- 2 pcs. 105400 bolt Ø 20 x 140, galv.
- 2 pcs. 018060 cotter pin 4/1, galv.

Art. no.	Weight [kg]	
124777	0.210	PERI Anchor Bolt 14/20 x 130

For temporary attachment to reinforced concrete components.

Note

Take the PERI Data Sheet into consideration!
Hole Ø 14 mm.

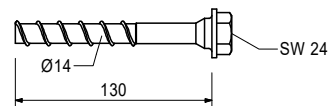
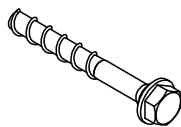

Art. no.	Weight [kg]	
109199	0.280	Bolt ISO 4017 M24 x 050-8.8, galv.

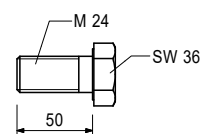
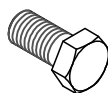

Art. no.	Weight [kg]	
130342	0.070	Hex. - Nut ISO 7042 M24-8, galv.

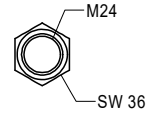

The optimal system
for all projects and
every requirement



Wall formwork



Column formwork



Slab formwork



Climbing systems



Bridge formwork



Tunnel formwork



Shoring



Working scaffolds for construction



Working scaffolds for facades



Working scaffolds for industry



Means of access



Safety scaffolds



Safety systems



System-independent accessories



Services



PERI Ltd
Formwork Scaffolding Engineering
 Market Harborough Road
 Clifton upon Dunsmore
 Rugby
 CV23 0AN
 +44 (0)1788 861600
 info@peri.ltd.uk
 www.peri.ltd.uk