

PERI UP Rosett Flex Working Scaffold 100 with Deck UDI

Instruction Manual for Standard Configurations

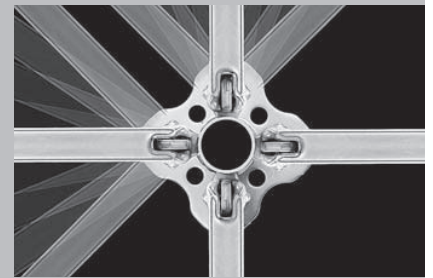

Contents

	Page		Page
Overview	2	Part D	
Introduction	3	Anchor Options	
General Information	4	D1 Top level not anchored	69
Part A		D2 Anchors at mid lift on section	70
Erecting and Dismantling		D3 Anchors between legs on plan	71
A1 Erecting the base	5	Part E	
A2 Erecting the first level	7	Work Safely	
A3 Erecting further scaffold levels	12	E1 Connection of safety harnesses	72
A4 Anchors	16	Part F	
A5 Installing supplementary components	19	Storage and Components	
A6 Dismantling	22	F1 Safe storage	73
Part B		Component list - Rosett Flex	76
Façade Scaffold Standard Configurations		Component list - Accessories	97
B1 Applied loadings	23		
B2 Anchor patterns	26		
B3 Anchor and base forces	51		
Part C			
Ancillary Applications			
C1 Scaffold access	54		
C2 Loading towers	59		
C3 Corners	60		
C4 Bridging obstructions and openings	62		
C5 Pedestrian access	63		
C6 Circular structures	64		
C7 Fixed joints in standards	66		
C8 Untied scaffolds	67		

Key:



Safety Precautions



Refer to Instructions



Visual Control



Hints



Site Tips

PERI UP Rosett Flex Working Scaffold 100 with Deck UDI

Overview - Components

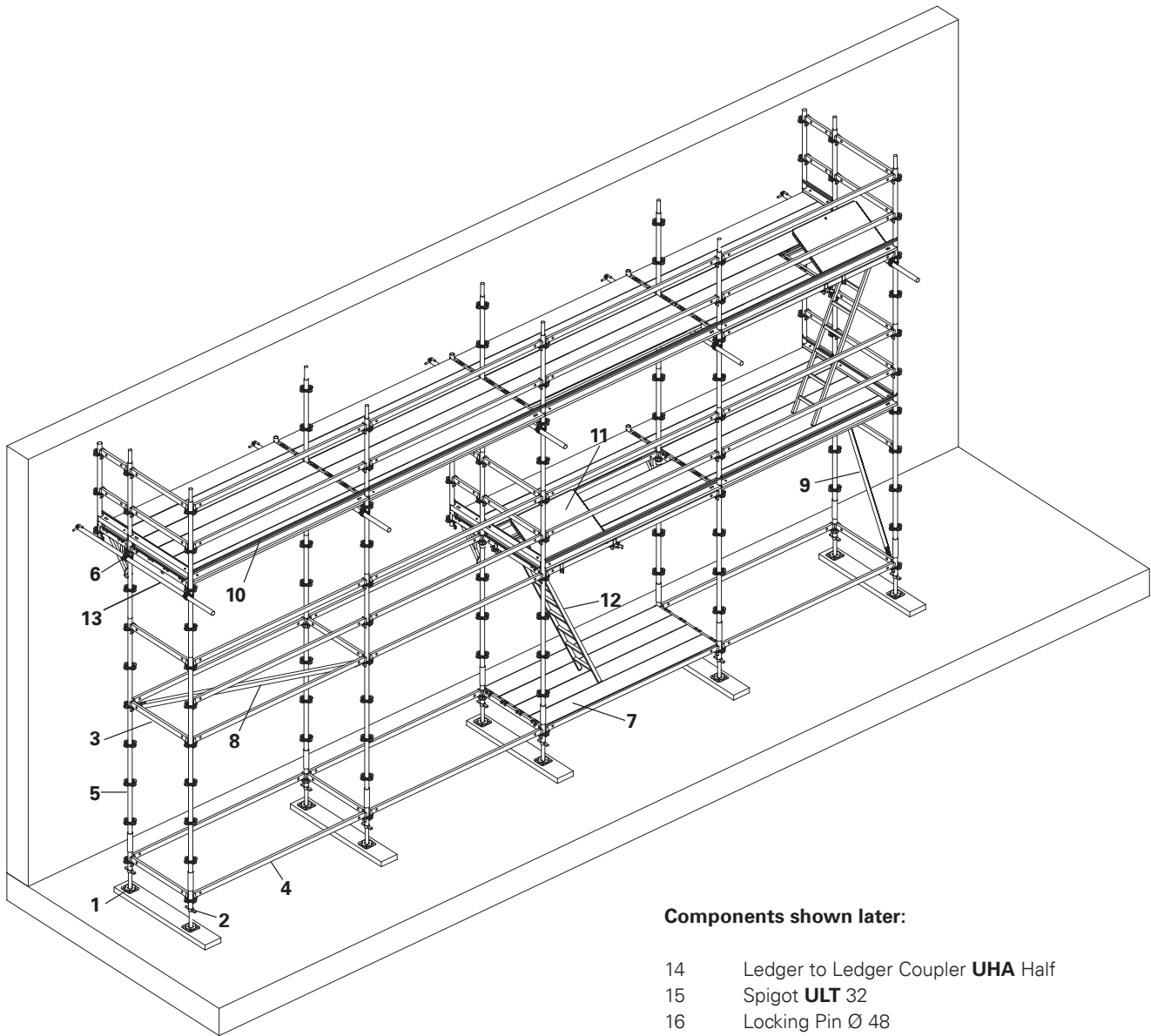

Components illustrated:

- 1 Adjustable Base Plate **UJB** 38-80/55
- 2 Base Standard **UVB** 24
- 3 Ledger **UH** 100 plus
- 4 Ledger **UH**
- 5 Standard **UVR / UVH**
- 6 Console Bracket **UCM** 50-2
- 7 Industrial Deck **UDI**
- 8 H-Brace **UBH**-Flex
- 9 Ledger Brace **UBL**
- 10 Toe Board **UPY**
- 11 Hatch **UAF** 75x100
- 12 Ladder **UAF** 200.
- 13 Wall Tie **UWT**

Components shown later:

- 14 Ledger to Ledger Coupler **UHA** Half
- 15 Spigot **ULT** 32
- 16 Locking Pin Ø 48
- 17 Console Bracket Brace **UCM**
- 18 Bottom Sheeting **UDP 100**
- 19 Corner Plate **UDC** 100
- 20 Staircase **UAS** 75
- 21 Stair Guardrail **UAG**
- 22 Spigot **UH.**
- 23 Ledger **UHV**
- 24 Loading Bay Gate
- 25 Deck Link Plate **UDC**
- 26 Ledger to Ledger Coupler **UHA**
- 27 Ledger to Ledger Coupler **UHA** w. Spigot
- 28 Stair Step **UAR** 100
- 29 Stair Stringer **UA** 250/200
- 30 Node Brace **UBK**
- 31 Stair Guardrail **UAH**
- 32 Coupler Brace **UBC**
- 33 Ring Bolt **UFE**

Introduction

Introduction

This manual provides assembly, modification and dismantling instructions. It is to form part of the customer's site specific method statement – but does not replace it.

The instructions are based on Approval Z-8.22-863 "PERI UP Rosett" Modular System.

The instructions:

- Regulate the intended use.
- Are a guidance for the customer for the assembly of the components and their handling.
- Provide references for stability requirements.
- Specify loads which are to be transferred from the anchors and spindles to load-bearing structural elements or into the ground (verification from the customer is required).

The instructions can not cover all the possible applications, because of the high flexibility and versatility of the system.

Examples shown in section C are subject to design, considering all possible loading combinations.

Please contact your local PERI office for more information.

Standard configuration:

Façade scaffold system width: 100cm

Used as a working scaffold in Load Classes 1-4 according to EN 12811-1

Bay lengths:

50 / 75 / 100 / 125 / 150 / 175 / 200 / 225 / 250 / 300cm

Standard configuration according to EN 12810

For a scaffold assembly: 24m high plus maximum spindle extension / internal brackets at every level / nets / closed sheeting

Product designation according to EN 12810:

**PERI UP Rosett Flex 100
EN 12810-4D-SW09/300-H1-B-LS**

Key:

- 4 = Service Load Class 4 (3.00 kN/m²)
- D = Platforms with drop test * (suitable as protection scaffold)
* - UAF Hatch items not tested!
- SW09 = Width Class 09 (100cm width)
- 300 = Bay length ≤ 300cm
- H1 = Headroom class
- B = With cladding facilities
- LS = Vertical access by ladders and by stairs

Important safety instructions:

The use of PERI UP Rosett Flex is intended only for professional applications as façade scaffolding in accordance with EN 12810-1:2003 (intended use).

Only PERI UP original components complete with the manufacturer's label are to be used.

The use of other products and accessories without prior consultation with PERI may introduce significant safety risks.

Any deviation from the standard configurations during assembly and / or use presents a potential safety risk and therefore may only be undertaken after a separate risk assessment has been carried out by the customer. Stability checks in accordance with EN 12811-1 and design specifications (Approval Z-8.22-863) will be required. Any additional requirements should be noted, added to the design drawings and contained within the site specific Method Statement.

Appropriate proof of stability can be ordered from PERI.

Deviations from these instructions, especially assembly sequences, require separate static proof.

Application

The scaffold for the appropriate load class, must be used in accordance with the minimum requirements of the 'Provision of Work Equipment Regulations (PUWER) 1998', 'The Construction (Design and Management) Regulations 2007' and 'The Work at Height Regulations 2005 (as amended)'.

General Information

Technical Suitability

PERI UP Rosett Flex may only be assembled, modified and dismantled by technically skilled scaffolding contractors and site personnel who also possess sufficient skill and experience (hereafter referred to as "customer").

Stability requirements

The customer has to guarantee on site that the bearing reactions of the scaffold can be safely transferred in to the foundation and anchorage.

The load bearing capacity of structure into which the wall ties are to be fixed must be verified for the anchoring forces that are to be induced.

Load distributing supports e.g. sleepers, are to be provided to match the ground conditions.

Conditions of the material

The material is to be regularly checked for any signs of damage particularly before any assembly takes place. Damaged components must be exchanged immediately on site and may no longer be used.

Bolted couplers must be tightened with a moment of 50Nm (corresponding to a force of 20kg with a 25cm lever arm). Wedge couplers are to be securely fitted using a 500g hammer.

Currently the following codes are of particular importance:

- EN 354: Lanyards
- EN 355: Energy absorbers
- EN 360: Retractable type fall arresters
- EN 361: Fully body harnesses
- EN 362: Connectors
- EN 363: Fall arrest systems

Scaffold tubes and couplers for mounting and bracing

Steel tubes and couplers are to be used as anchors and as bracing. Steel tubes with a 48.3mm external diameter and at least 3.2mm wall thickness according to EN 39 as well as couplers according to EN 74 with appropriate markings are to be used.

Personal protective equipment against falls from a height

When using personal protective equipment against falls from a height, all valid standards and safety regulations are to be taken into consideration by the customer.

Availability of the Instruction Manual

This instruction manual, together with the method statement from the customer, must be made available for the entire period, from the beginning of the assembly work through to the end of the dismantling, and including the service life at the point of use. (see EN 12811-1:2003 Section 8)

Additional regulations:

The customer must observe all valid laws and safety regulations regarding assembly and use.

Currently, the following is of particular importance:

"Council Directive 89/655/EEC and 2001/45/EC of the European Parliament concerning the minimum health and safety requirements for the use of work equipment by workers at work"

Signs

If certain parts of the scaffolding are not ready for use – in particular during assembly, alteration work and dismantling – a "No Entry" warning sign restricting access must be clearly displayed, (See Sign 1). In addition it must be made clear through appropriate physical means that the scaffold is incomplete and may not be accessed.



Sign 1



Sign 2

After handover, the scaffolding is to be marked in such a way so that the intended use is clearly visible (Sign 2).

The sign does not replace the inspection record!

A – Erection and Dismantling

A1 Erecting the base

Erecting the scaffold must follow the sequence described below!

A1.1 Load distributing base area

Always begin erecting at the highest point, preferably at an internal corner.



Settlement must be avoided! The scaffold must only be erected on suitable distribution plates on ground or structure capable of withstanding all imposed loads!

Lay the Ledgers UH (4) and Ledgers UH 100 Plus (3) down to determine the length of the surface to be scaffolded. This will fix the distance between the Adjustable Base Plates UJB 38-80/55 (1)

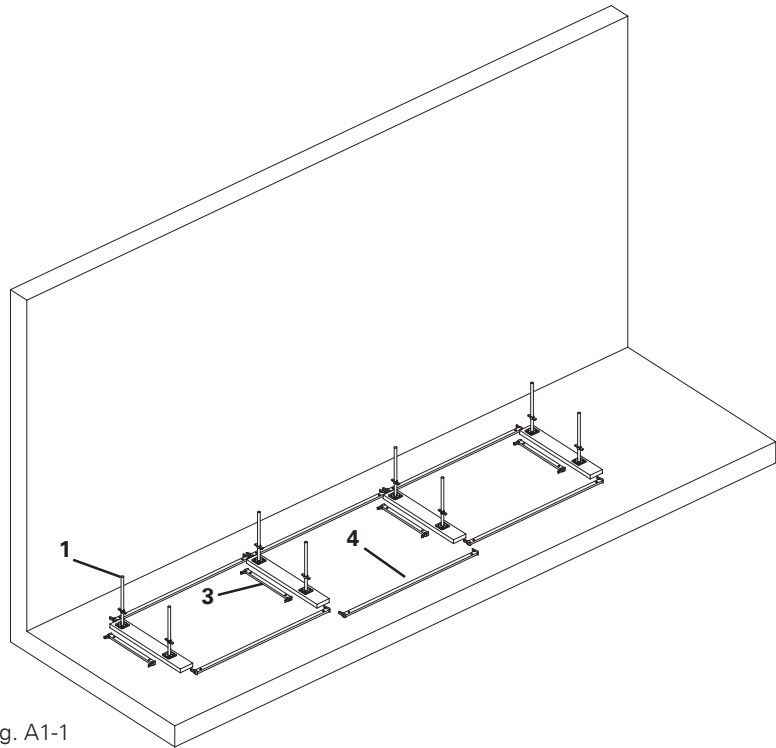

Fig. A1-1

A1.2 Adjustable Base Plates UJB

Position Adjustable Base Plates UJB 38-80/55 (1) at the ends of the Ledgers UH 100 Plus (3) & Ledgers UH (4).



Adjustable Base Plates UJB 38-50/30 with red handles have a maximum extension of 355mm to top of collar handle. Check with PERI for suitability of use.



Base Spindles TR 38-70/50 may be used instead of Adjustable Base Plates UJB (1). Extension range = 47mm – 535mm to top of collar handle.

A1.3 Changes in base level

Steps, slopes and changes in level can be accommodated using differing vertical Standards UVR.

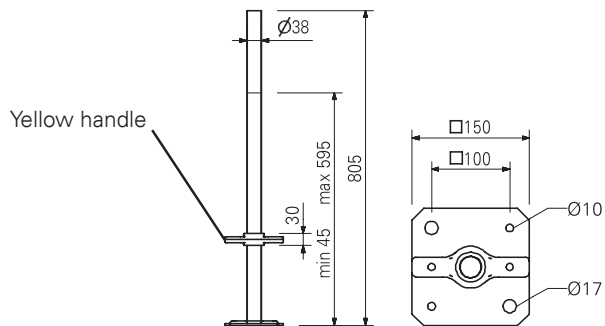

Fig. A1-2

UJB 38-80/55

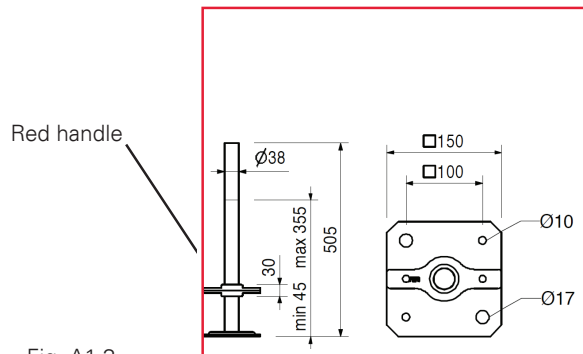

Fig. A1-3

UJB 38-50/30

A1 Erecting the base

A1.4 Base Standard UVB

Place Base Standards UVB 24 (2) over the Adjustable Base Plates UJB (1) and position at the required distance from the wall. Ensure all UVB Ø11 holes are in alignment.

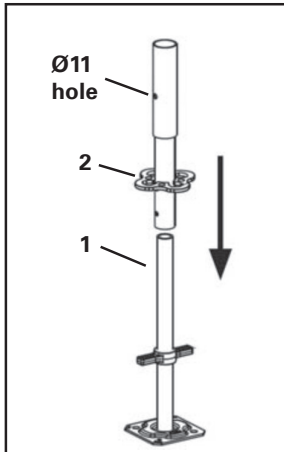

Fig.A1-4

A1.5 Ledger UH

Form a base frame by connecting the Base Standard UVB 24 (2) transversely with the Ledger UH 100 Plus (3) and longitudinally with the Ledger UH (4).

Ensure all Ledgers UH are level by adjusting the Adjustable Base Plates (1).

Place Industrial Decks UDI (7) on the Ledgers UH 100 Plus (3) as an assembly aid to check squareness.

Do not secure Ledger wedges at this stage



The decks used at the base are an aid to erection only, they may be removed later. Decks erected in a ladder bay remain in place to support the ladder & to provide a safe landing.

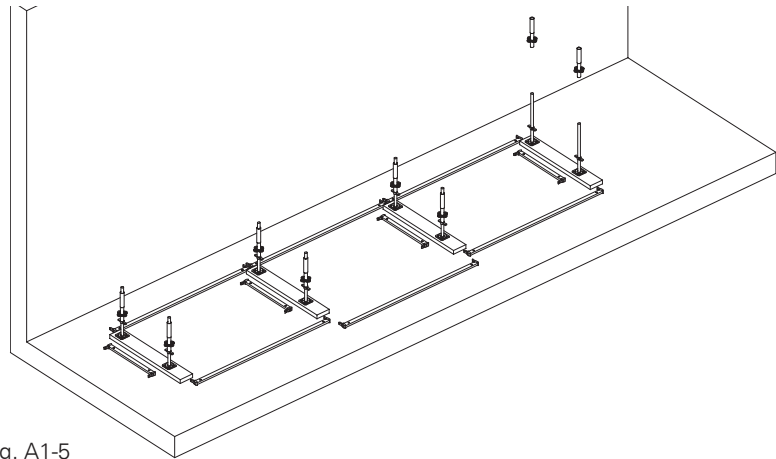

Fig. A1-5

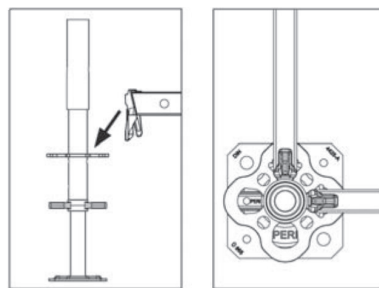

Fig. A1-6

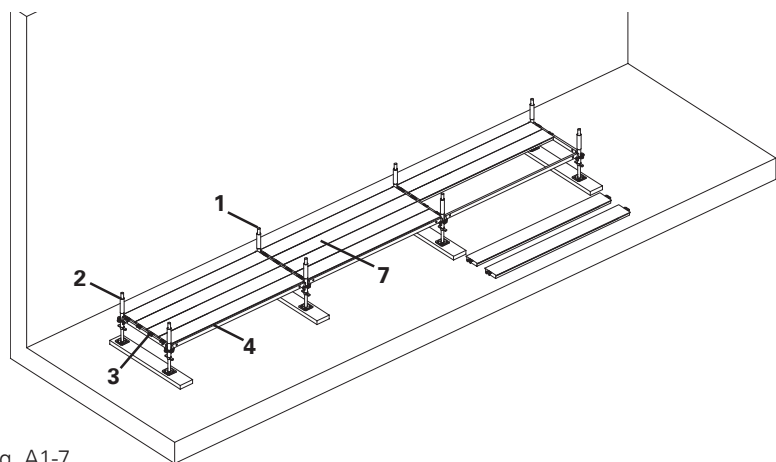

Fig. A1-7

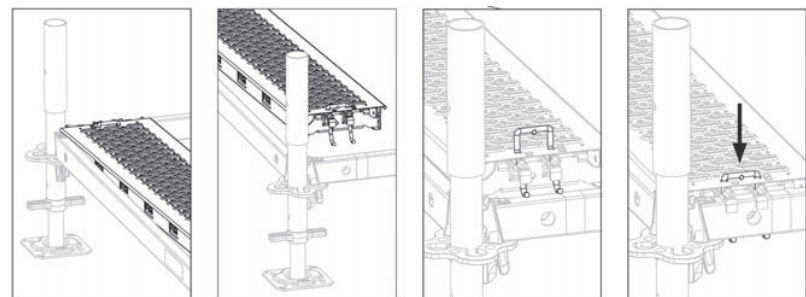

Fig. A1-8

PERI UP Rosett Flex Working Scaffold 100 with Deck UDI

A2 Erecting the first level

A2.1 Vertical Standards UVR

PERI recommend using UVR 300 **(5)** on the inside and outside at the first level.

Other combinations of standards (e.g. UVR 200 inside with UVR 300 outside) are structurally acceptable, but the customer must ensure safe method of erection & striking.

Insert Vertical Standards UVR **(5)** into the inner Base Standards UVB **(2)** ensuring alignment of the Ø11 holes.

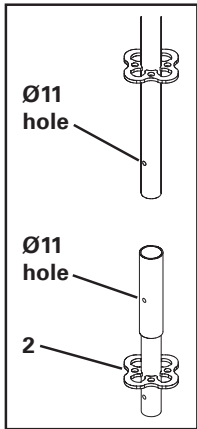

Fig. A2-1

Attach UH Ledgers 100 Plus **(3)** to the top Rosett on the Vertical Standards UVR **(5)** and insert into the outer Base Standards UVB **(2)**, then securely fix all wedges at UVB level using a 500g hammer.

A2.2 Ledgers UH & Console Brackets UCM

For the next level, fit internal longitudinal Ledgers UH **(4)** & transverse Ledgers UH 100 Plus **(3)** in the Rosettes of the Vertical Standards **(5)** and secure the wedges.

Fit any required Console Brackets UCM **(6)** in the Rosettes and secure the wedges,



If required by the Standard Configuration anchor pattern in Section B, fit the base level Ledger Braces UBL and Ledgers UH 100 Plus.

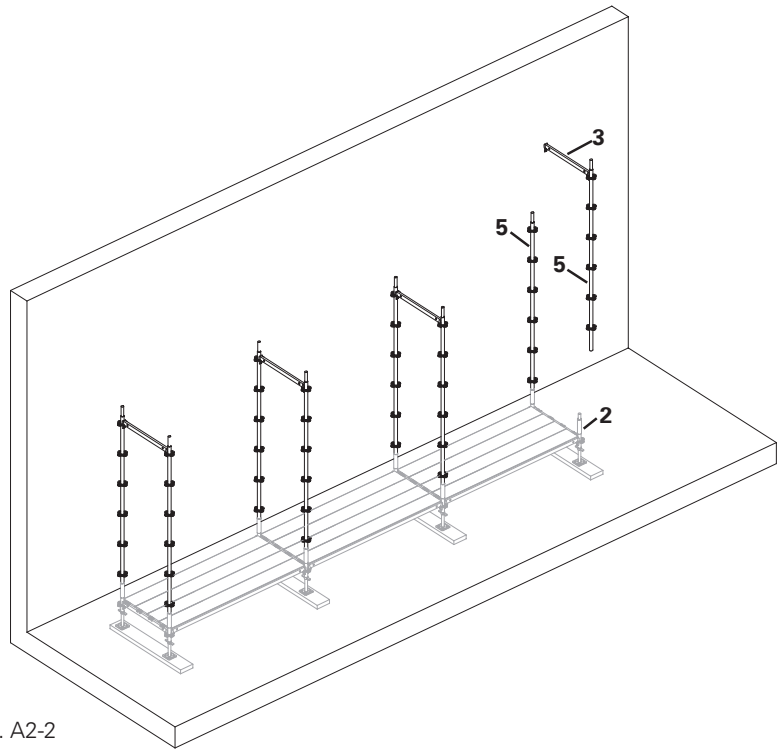

Fig. A2-2

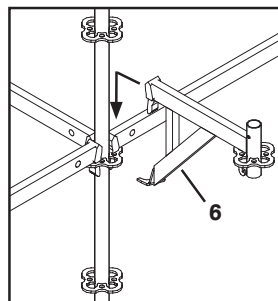

Fig. A2-3a

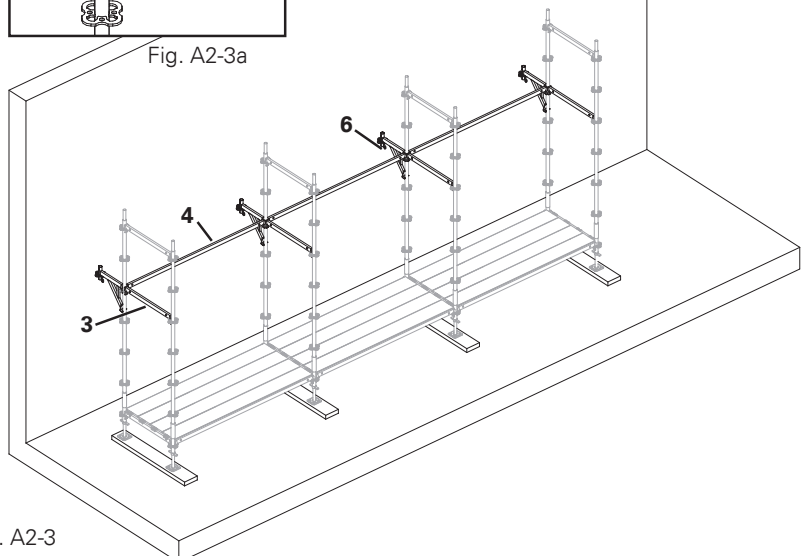

Fig. A2-3

PERI UP Rosett Flex Working Scaffold 100 with Deck UDI

A2 Erecting the first level

A2.3 Temporary erection platform

Fit temporary longitudinal Ledgers UH (4a) in an end bay.

Fit temporary Industrial Decks UDI 100 (7a), stepped to 1.0m below the first lift of UDI decks.

A2.4 Hatch UAF

Fit the hatch support longitudinal Ledger UH (4) and Ledger UH 75 (4) but do not fit the Hatch UAF (11) at this stage.



For fixing Ledgers UH to Ledgers UH to support the Hatch UAF (11), use Ledger to Ledger Coupler UHA Half (14) fitted with wedges fixed from outside of the hatch opening.

From the temporary platform erect the guard rail Ledgers UH 100 Plus (3) & longitudinal Ledgers UH (4) and secure the wedges.

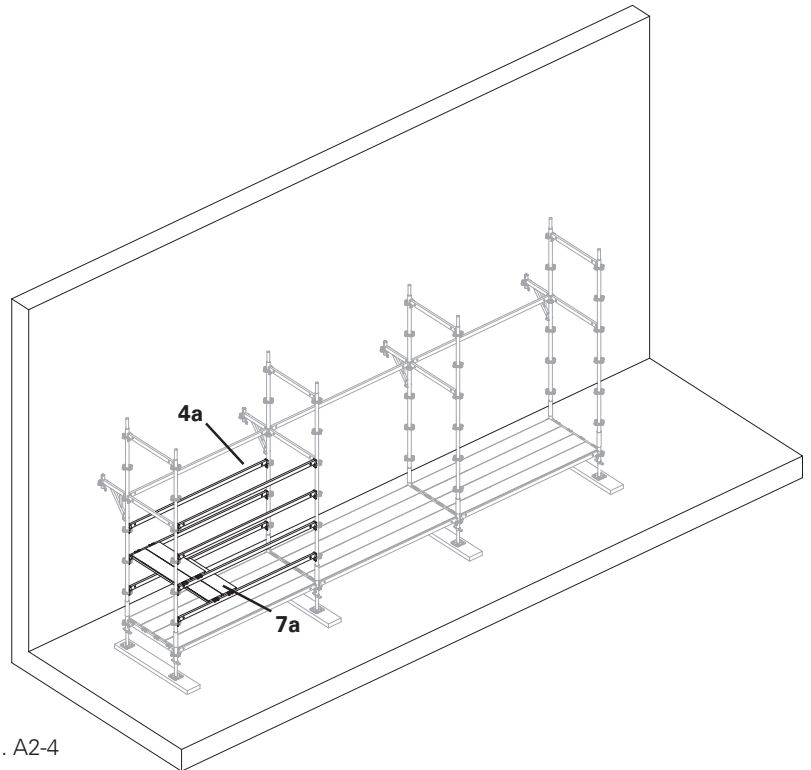

Fig. A2-4

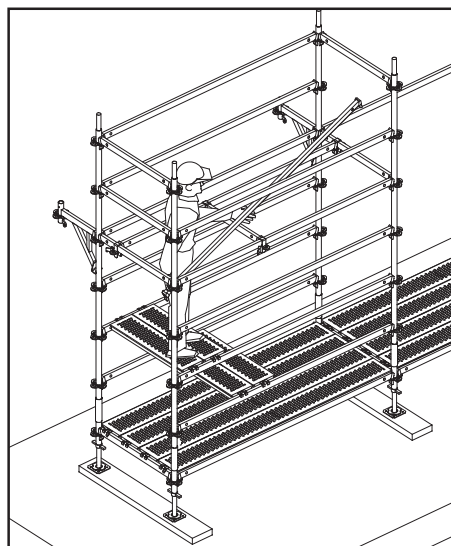

Fig. A2-5

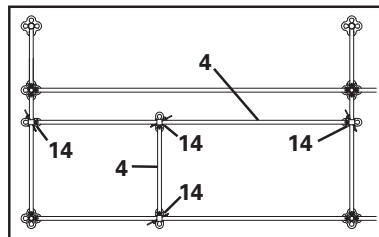

Fig. A2-6a



Fig. A2-6b

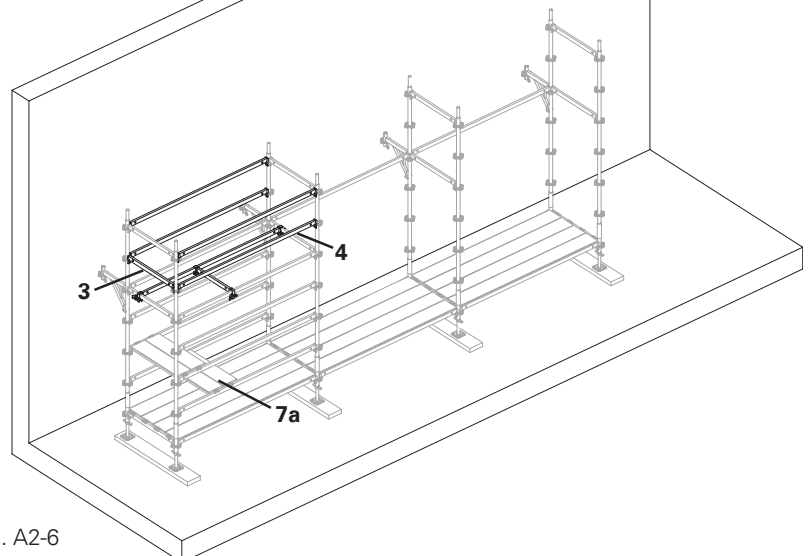

Fig. A2-6

PERI UP Rosett Flex Working Scaffold 100 with Deck UDI

A2 Erecting the first level

A2.5 Industrial Decks UDI

Remove temporary platforms from hatch bay and fit Hatch UAF (11) and Ladder UAF 200 (12).



The Hatch UAF (11) must remain closed at all times when not in use!

Fit Industrial Decks UDI (7) to Ledgers UH 75 (4), UH 100 Plus (3) and Console Brackets UCM (6) from below.

Fit Toe Boards UPY (10) in first bay.

Temporary Industrial Decks UDI (7) fitted at base level may now be removed except at ladder locations.

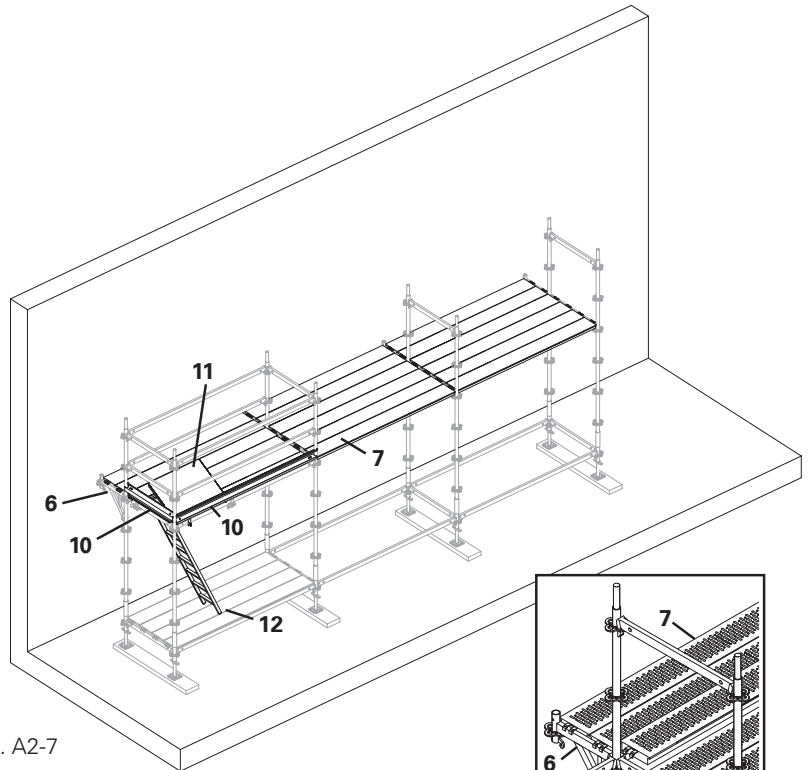

Fig. A2-7

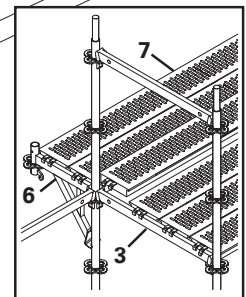

Fig. A2-7a

A2.6 Edge protection

Working from behind Ledgers UH 100 Plus (3a), fit longitudinal Ledgers UH (4) and temporary Ledgers UH (4a).

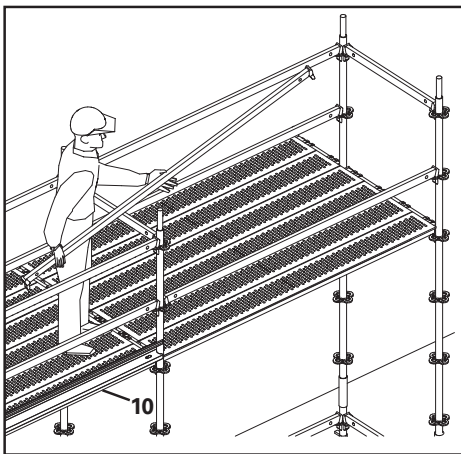

Fig. A2-8

Once Ledgers UH (4 & 4a) are fixed, remove temporary Ledger UH 100 plus (3a) and fit edge Toe Boards UPY (10). Secure wedges to all UH Ledgers, and progress sequence to end bay.

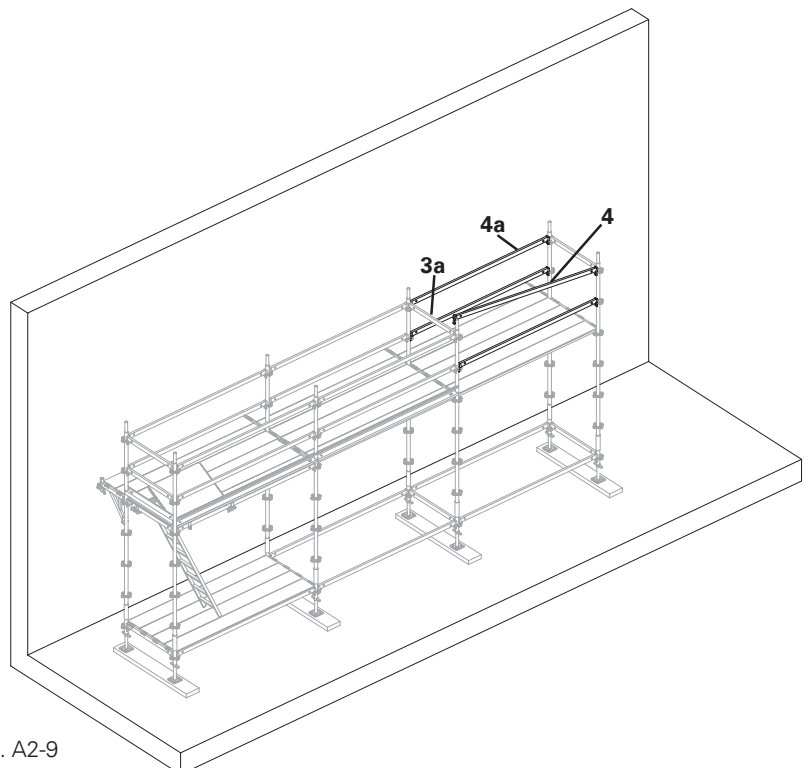

Fig. A2-9

A2 Erecting the first level

A2.7 UCM edge protection

A2.7.1

Fit the intermediate Ledger UH 100 Plus **(3)** and Toe Board UPY **(10)** to the end bay.

From behind longitudinal Ledgers UH **(4a)**, fit vertical Standards UVR / UVH **(5)** with appropriate Spigot ULT **(15)** & Locking Pins \varnothing 48 **(16)** to Console Brackets UCM **(6)**.



Fit Spigot ULT **(15)** to Standard UVR / UVH **(5)** prior to connecting to Console Bracket UCM **(6)**.

Fit edge protection Ledgers UH **(4)** and Toe Boards UPY **(10)** to end Console Brackets UCM **(6)**.

Fit temporary Ledger UH **(4a)** to internal Console Brackets UCM **(6)**.

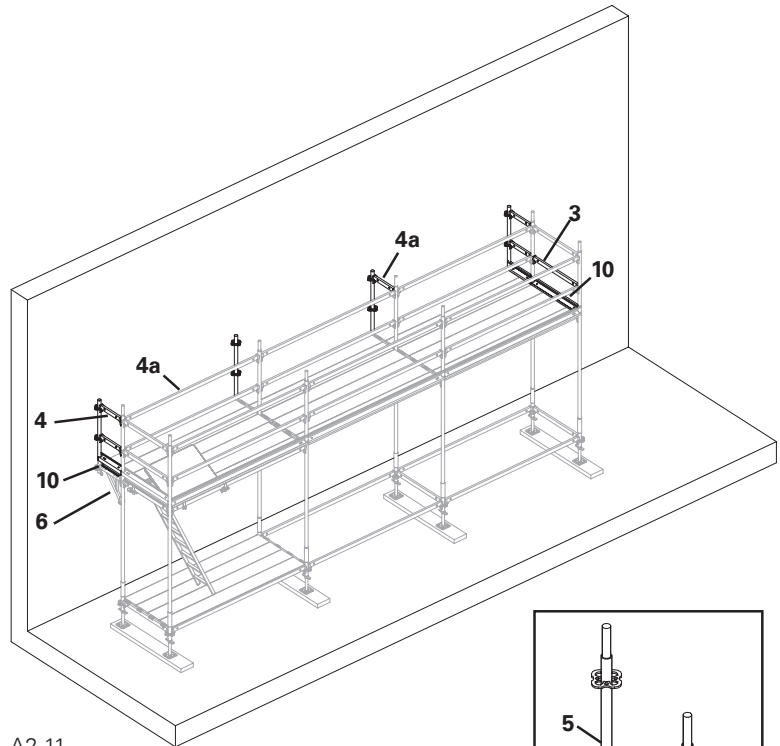

Fig. A2-11

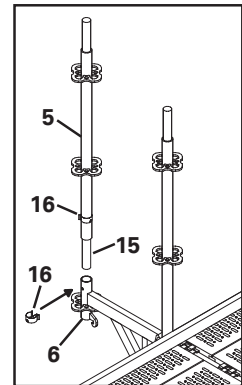

Fig. A2-10

A2.7.2

Working from behind longitudinal Ledgers UH **(4a)**, fit longitudinal Ledgers UH **(4)**. Remove temporary Ledgers UH **(4a)** and fit Toe Boards UPY **(10)** to the front of UCM platform.



Temporary longitudinal Ledgers UH **(4a)** may now be removed from the first bay for use in the next.

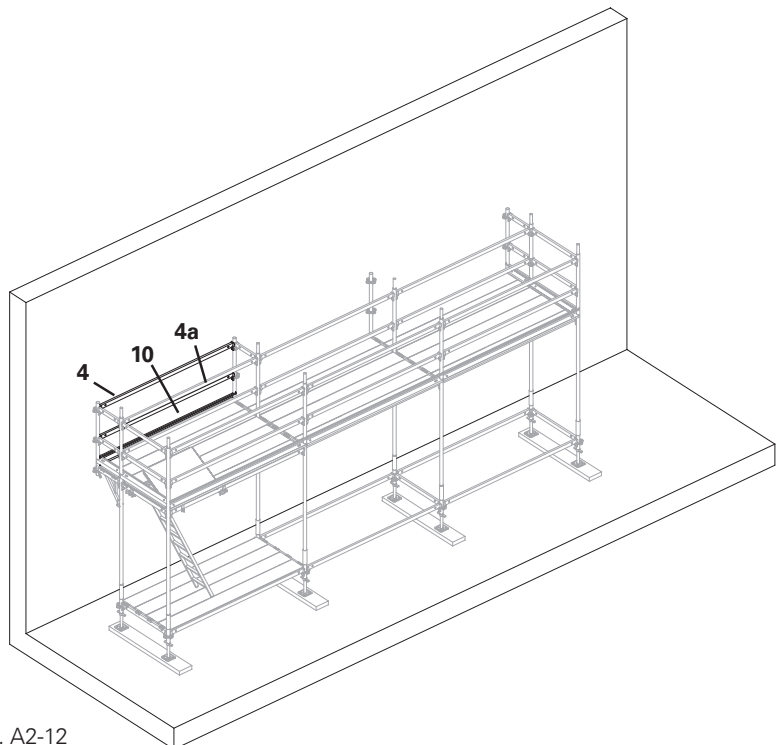

Fig. A2-12

PERI UP Rosett Flex Working Scaffold 100 with Deck UDI

A2 Erecting the first level

A2.7.3

Working behind temporary guard rail
Ledgers UH **(4a)**, progress sequence
repeating previous stage to end bay.

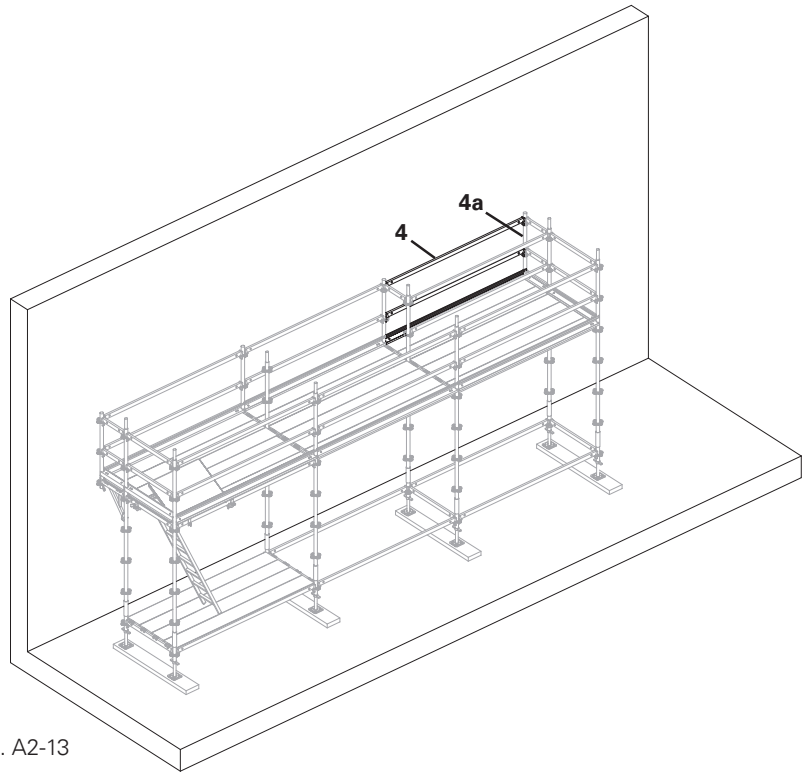

Fig. A2-13

A2.8 Complete lift

Remove final bay temporary guard rail
Ledger UH **(4a)**. **First lift completed.**

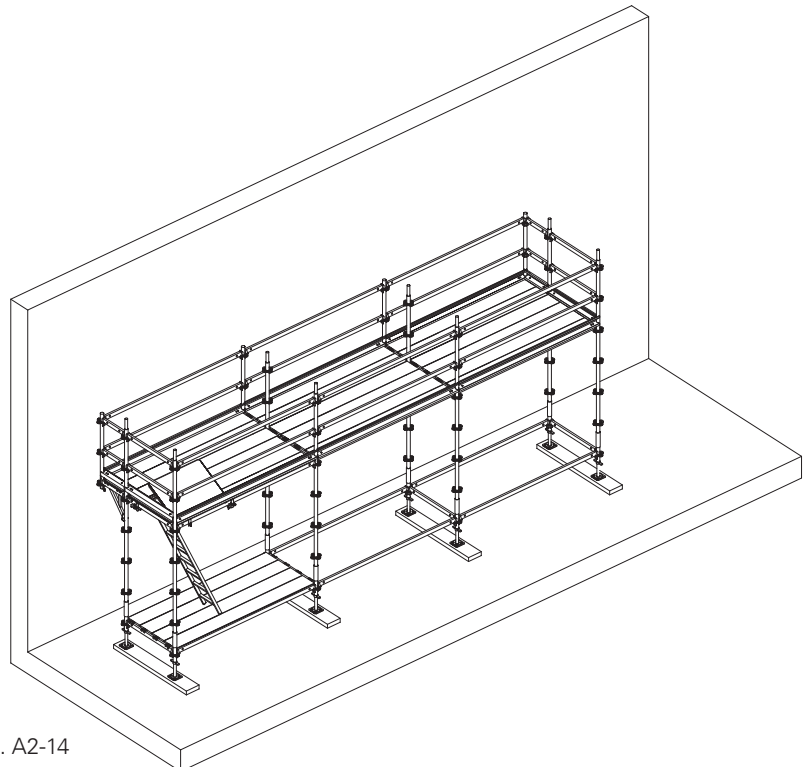

Fig. A2-14

PERI UP Rosett Flex Working Scaffold 100 with Deck UDI

A3 Erecting further scaffold levels

A3.1 Vertical Standards UVR

PERI recommend using UVR 200 (5) on the inside and outside at the upper levels.

Insert Vertical Standards UVR (5) into the inner Standards UVR (5) ensuring alignment of the Ø 11 holes.

Attach UH Ledgers 100 Plus (3) to Vertical Standards UVR (5) and insert into the outer Vertical Standards UVR (5).

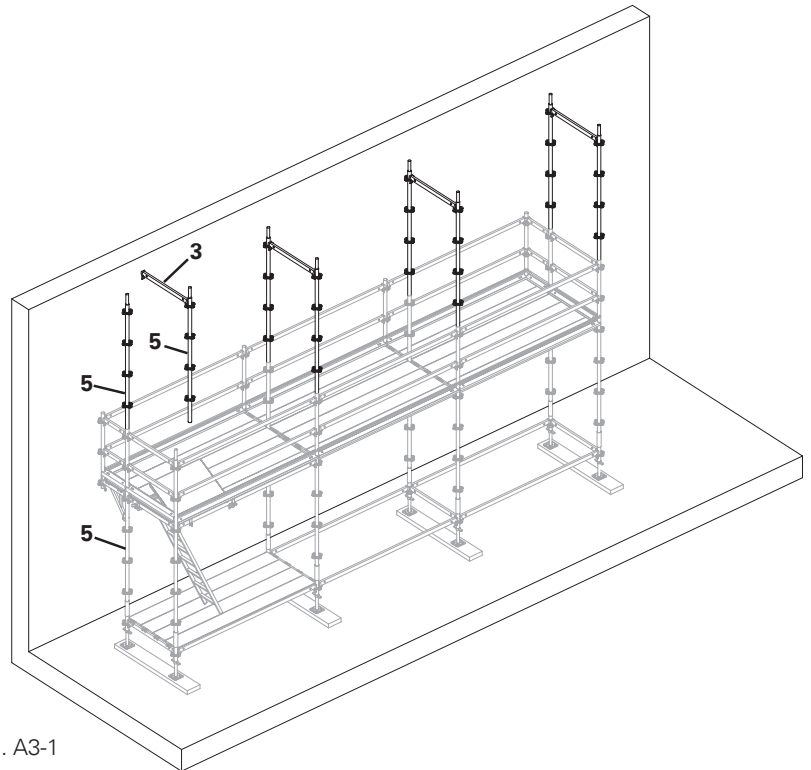

Fig. A3-1

A3.2 Ledgers UH & Console Brackets UCM

For the next level, fit the longitudinal Ledgers UH (4) & transverse Ledgers UH Plus (3) in the Rosettes of the Vertical Standards (5) and secure the wedges.

Fit any required Console Brackets UCM (6) in the Rosettes and secure the wedges.

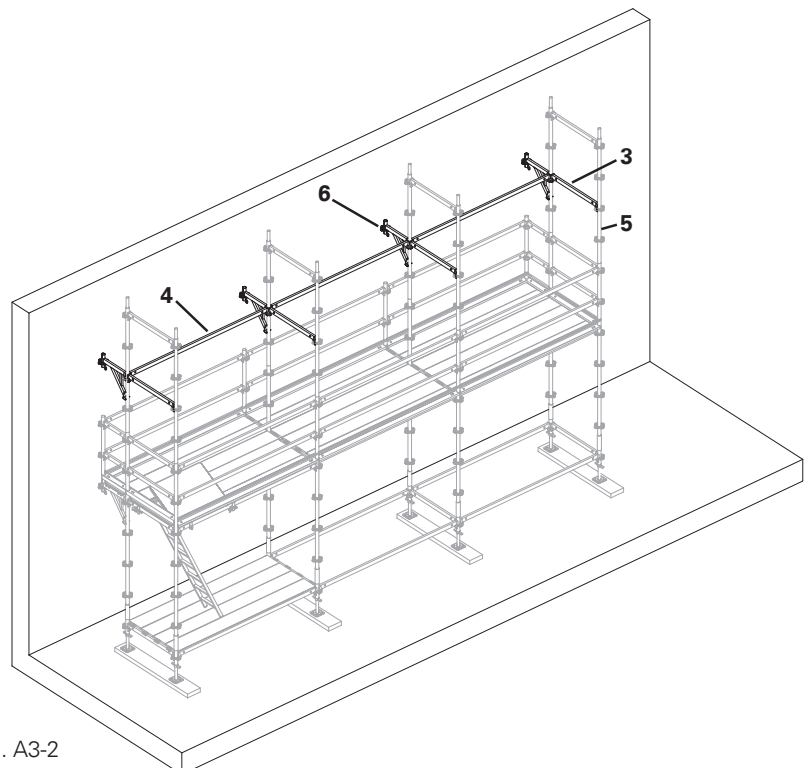

Fig. A3-2

PERI UP Rosett Flex Working Scaffold 100 with Deck UDI

A3 Erecting further scaffold levels

A3.3 Temporary erection platform

Fit temporary longitudinal Ledgers UH (4a) in an end bay.

Fit temporary Industrial Decks UDI 100 (7a), stepped to 1.0m below the next level of UDI decks.

A3.4 Hatch UAF

Fit the hatch support longitudinal Ledger UH (4) and Ledger UH 75 (4) but do not fit the Hatch UAF (11) at this stage.

From the temporary platform erect the guard rail Ledgers UH 100 Plus (3) & longitudinal Ledgers UH (4) and secure the wedges.



Position Hatches UAF (11) at opposing end bays, alternating the direction of the Ladders UAF 200 (12). The Hatch UAF (11) must remain closed at all times when not in use!

A3.5 Industrial Decks UDI

Remove temporary platforms from hatch bay and fit Hatch UAF (11) and Ladder UAF 200 (12).

Fit Industrial Decks UDI (7) to Ledgers UH 75 (4), UH 100 Plus (3) and Console Brackets UCM (6) from below.

Fit Toe Boards UPY (10) in first bay.

A3.6 Anchors

Anchoring (13) is carried out progressively from below during erection of the scaffold. Ensure anchors are fitted before moving on to upper deck level.



Assembly of the anchors is set out in section A4, and the required tie patterns for Standard Configurations are set out in section B.

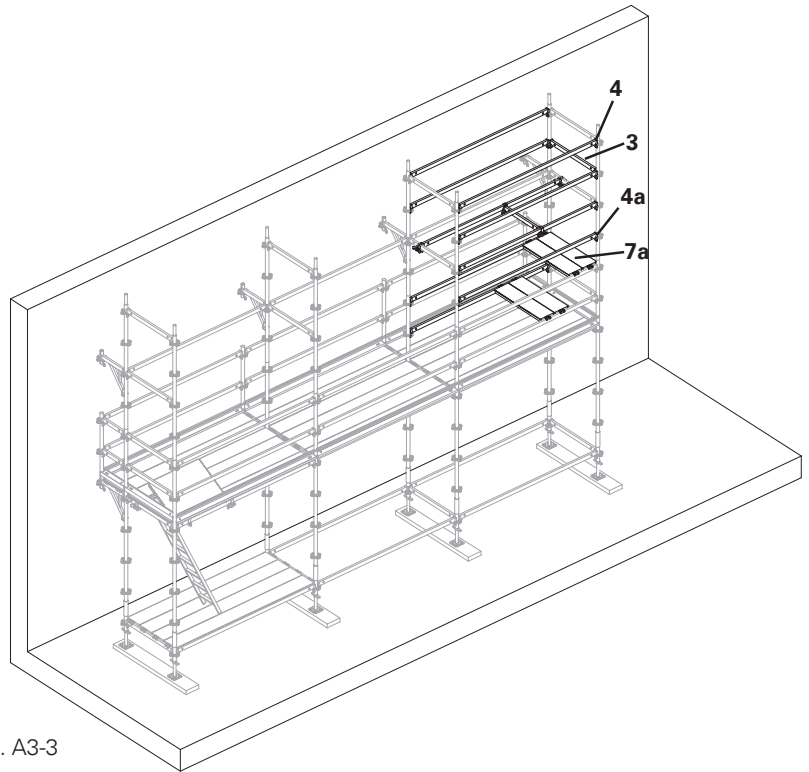

Fig. A3-3

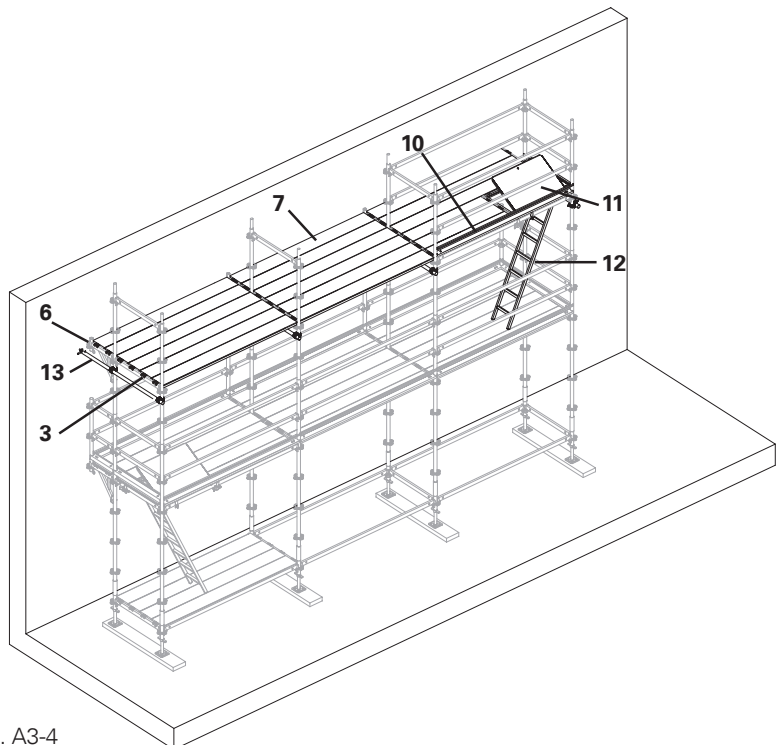

Fig. A3-4

PERI UP Rosett Flex Working Scaffold 100 with Deck UDI

A3 Erecting further scaffold levels

A3.5 Edge protection

Working from behind Ledgers UH 100 Plus **(3a)**, fit longitudinal Ledgers UH **(4)** and temporary Ledgers UH **(4a)**.

Once Ledgers UH **(4 & 4a)** are fixed, remove temporary Ledger UH 100 Plus **(3a)**, fit edge Toe Boards UPY **(10)** and progress sequence to end bay.

Fit the intermediate Ledger UH 100 Plus **(3)** and Toe Board UPY **(10)** to the end bay.

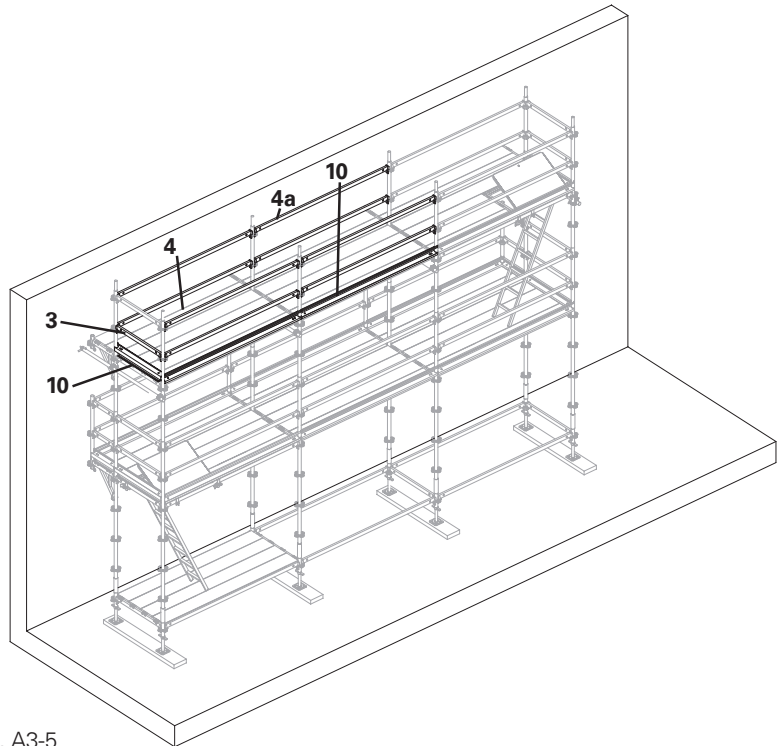

Fig. A3-5

A3.6 UCM edge protection

A3.6.1

From behind longitudinal Ledgers UH **(4a)**, fit vertical Standards UVR / UVH **(5)** with appropriate Spigot ULT **(15)** to Console Brackets UCM **(6)**. Alt. Use Console Brackets UCM with Welded Spigot

Fit edge protection Ledgers UH **(4)** and Toe Boards UPY **(10)** to end Console Brackets UCM **(6)**.

Fit temporary Ledger UH **(4a)** to internal Console Brackets UCM **(6)**.

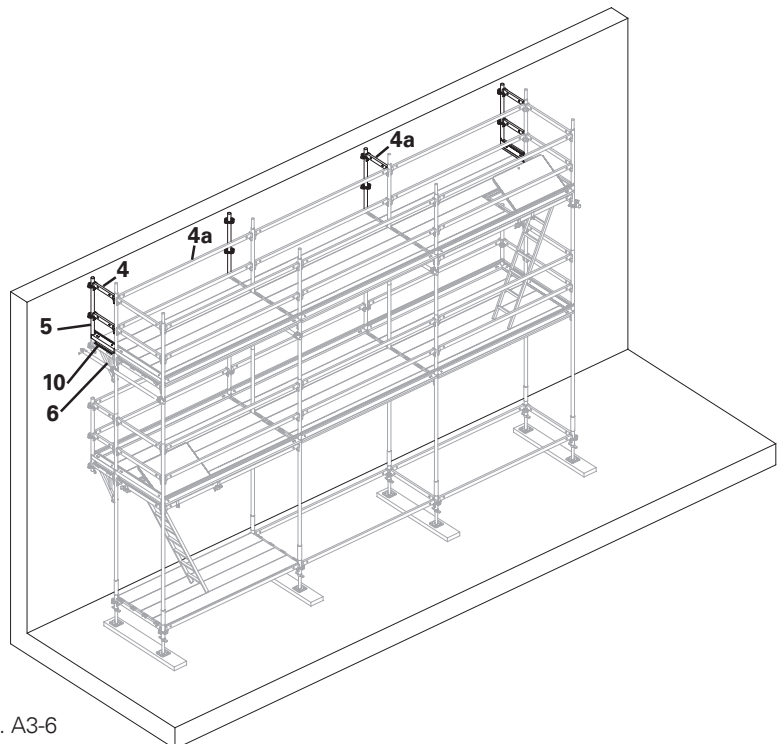

Fig. A3-6

PERI UP Rosett Flex Working Scaffold 100 with Deck UDI

A3 Erecting further scaffold levels

A3.6.2

Working from behind longitudinal Ledgers UH (4a), fit longitudinal Ledgers UH (4). Remove temporary Ledgers UH (4a) and fit Toe Boards UPY (10) to the front of UCM platform. Progress the sequence to all bays.

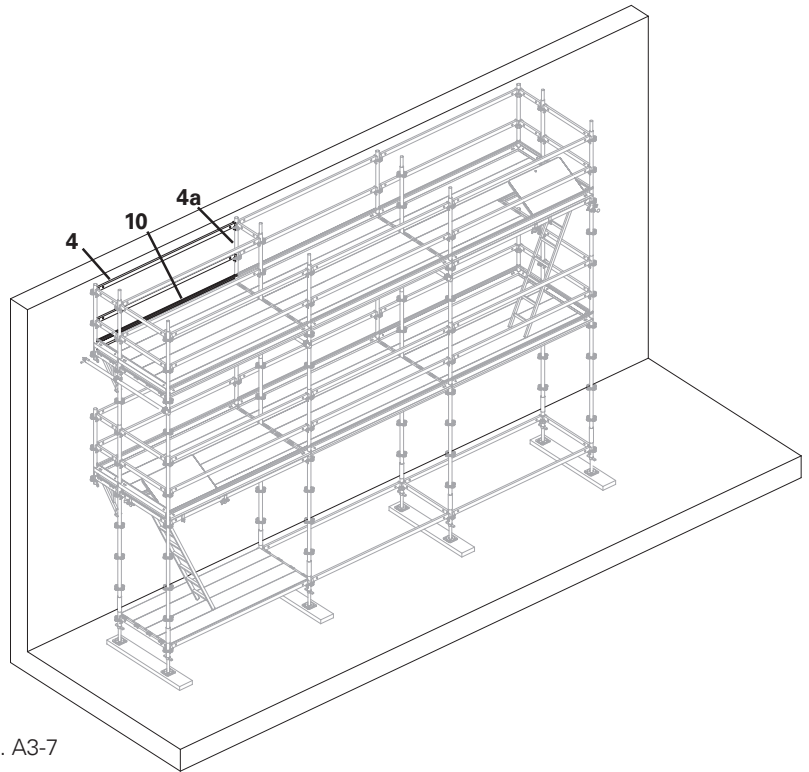

Fig. A3-7

A3.7 Complete lift

Next lift completed.

Commence erection of further levels following the sequence from section A3.1

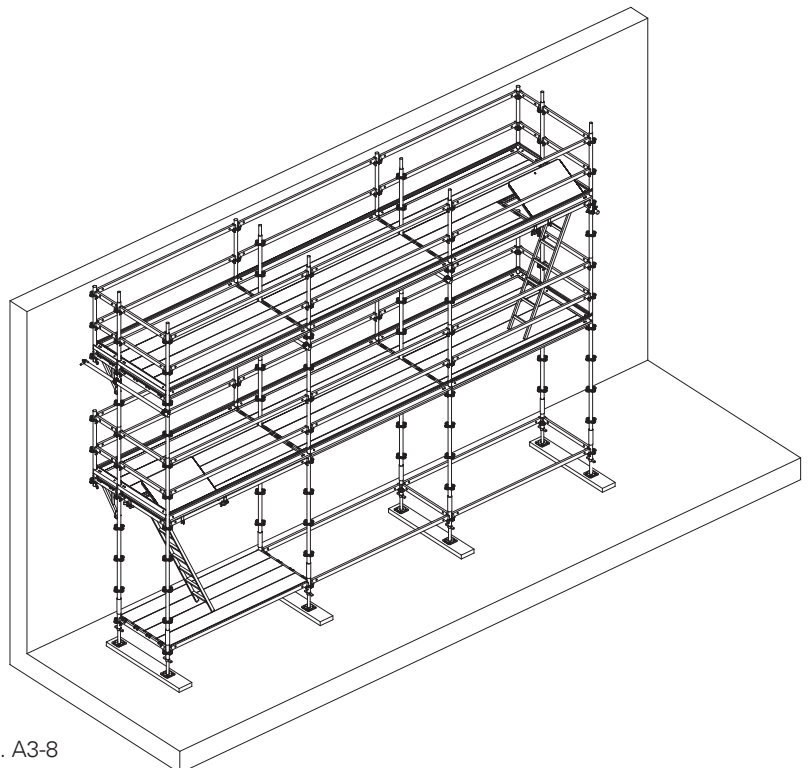

Fig. A3-8

PERI UP Rosett Flex Working Scaffold 100 with Deck UDI

A4 Anchors

A4.1 General

Anchoring is carried out progressively during the erection of the scaffold in accordance with the appropriate anchor pattern. Ring Bolts UFE (33) may be used for fixing to the structure. Wall Ties UWT (13) are fitted directly to the standards UVR (5) with scaffold couplers to EN 74-1:2005 up to 0.4m above or below the Ledger UH 100 plus (3) level.



Anchors do not carry vertical loads!



The Wall Tie UWT (13) should be fitted as close as possible to the Ledger UH 100 Plus (3) to give the greatest head-room through the scaffold lift and so that the Console Brackets UCM can be fitted without difficulty.



If Console Brackets UCM (6) are being fitted at a later stage, ensure Wall Ties UWT (13) are positioned to avoid clashing.

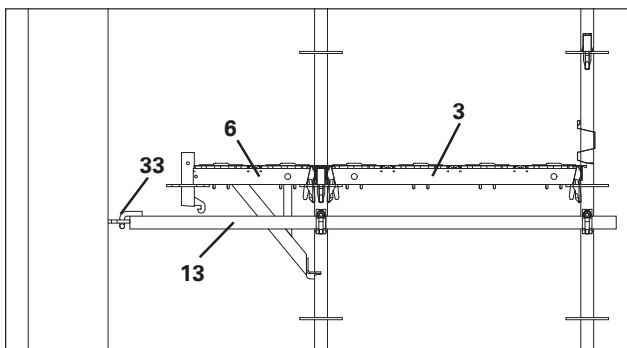
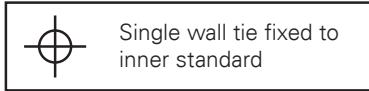

Fig.A4-1

A4 Anchors

A4.2 Single wall ties



The Wall Tie UWT (13) is fixed to the inner Standard UVR (5) using Right Angle Coupler .

Tensile & compressive forces are transferred perpendicular to the façade (A_⊥) .

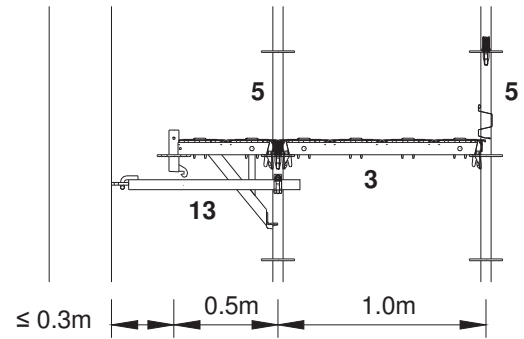

Fig.A4-2

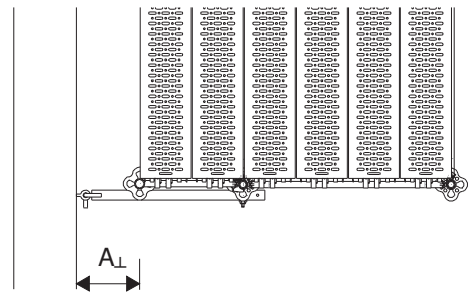
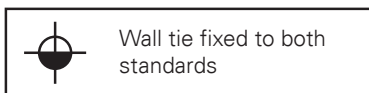

Fig.A4-3

A4.3 Wall ties



The Wall Tie UWT (13) is fixed to the both inner and outer Standard UVR (5) using Right Angle Couplers.

Tensile & compressive forces are transferred perpendicular and parallel to the façade (A_⊥ and A_∥) .

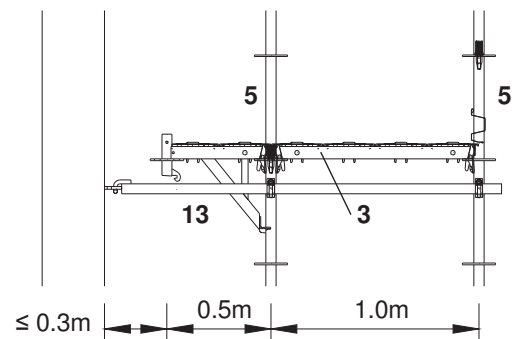

Fig.A4-4

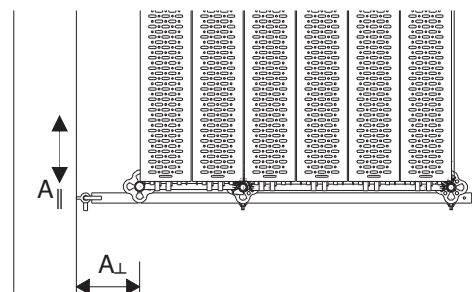

Fig.A4-5

PERI UP Rosett Flex Working Scaffold 100 with Deck UDI

A4 Anchors



A4.4 Triangulated Anchors

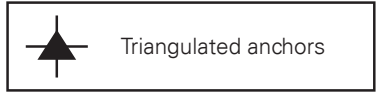

Triangulated anchors

Two Wall Ties UWT **(13)** are fixed at an angle of 45° using Right Angle Couplers.

Connection options:

- Connect both Wall Ties **(13)** to the standard UVR **(5)** with Right Angle Couplers.
- or
- Connect the first Wall Tie **(13)** to the standard UVR **(5)** and the second Wall Tie **(13)** to the first at 90°. Both connections with Right Angle Couplers.

Tensile & compressive forces are transferred perpendicular and parallel to the façade (A_{\perp} and A_{\parallel}).

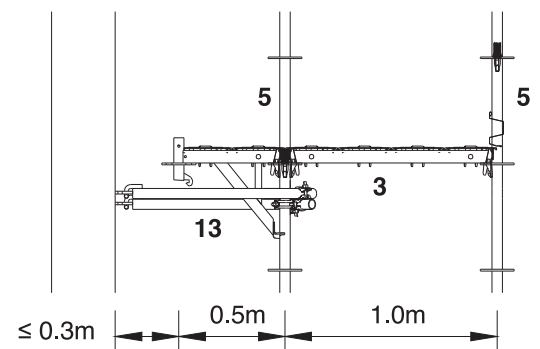

Fig.A4-6

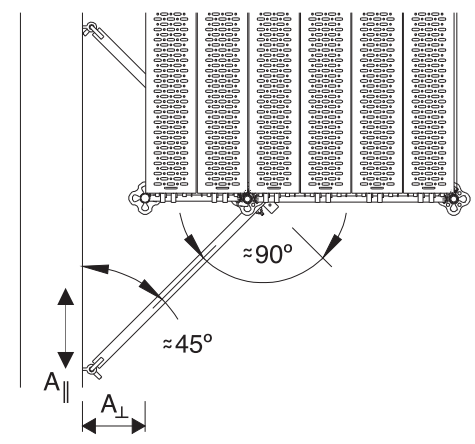
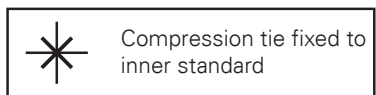

Fig.A4-7

A4.5 Compression wall ties



Compression tie fixed to inner standard

The Wall Tie UWT **(13)** is fixed to the inner Standard UVR **(5)** using a Right Angle Coupler.

The tube end without the hook is positioned against the façade.

Compressive forces only are transferred perpendicular to the façade (A_{\perp}).

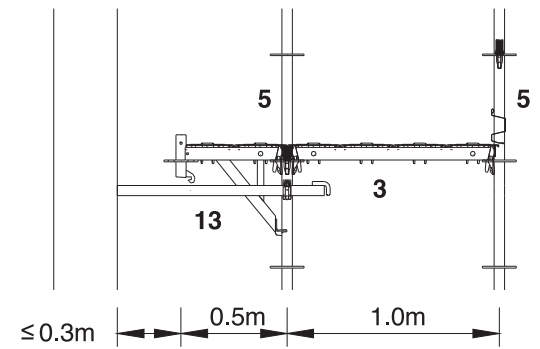

Fig.A4-8

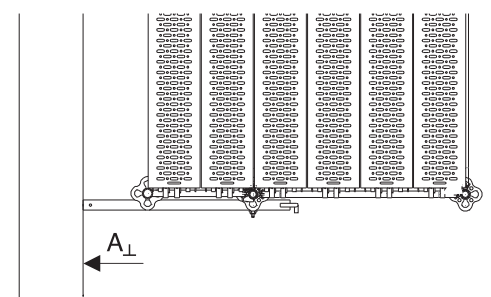

Fig.A4-9

PERI UP Rosett Flex Working Scaffold 100 with Deck UDI A5 Installing supplementary components

A5.1 Use of scaffold brackets

Scaffold brackets allow internal and external widening of the scaffold levels by 0.25m, 0.5m or 0.75m.

The brackets fit on to a Rosett in the same way as a Ledger UH and the wedge secured with a hammer blow.

A5.1.1 Console bracket UC 25

Allows widening of scaffold to support single Industrial Deck UDI 25

UC 25:

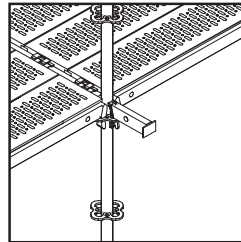

Fig. A5-1

A5.1.2 Console brackets UCM 50 & UCM 75

Allows widening of scaffold to support two or three Industrial Deck UDI 25. Available in three types:

Type 1

Console brackets with Rosett and no spigot.

UCM 50:

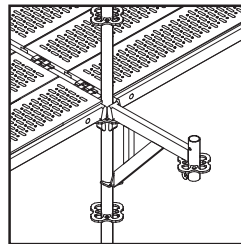

Fig. A5-2

UCM 75:

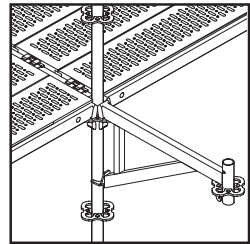

Fig. A5-3

Type 2

Console brackets with half Rosett and no spigot.

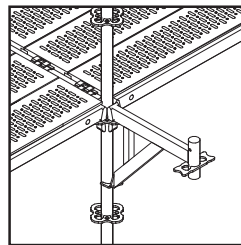

Fig. A5-4

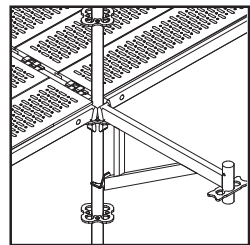

Fig. A5-5

Type 3

Console brackets with Rosett and welded spigot.

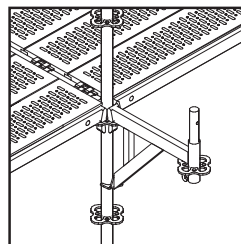

Fig. A5-6

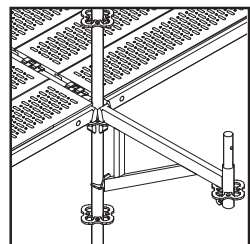

Fig. A5-7

PERI UP Rosett Flex Working Scaffold 100 with Deck UDI

A5 Installing supplementary components

A5.2 Console Brackets UCM with post

A vertical Standard UVR (5) with a Spigot ULT (15) and Locking Pin \varnothing 48 or M10 Bolt (16) added is required for Console Brackets UCM (6) without spigots.



When attached to the Console Bracket UCM (6) with a locking pin \varnothing 48 (16), the Spigot ULT (15) cannot fall through the end tube if the upper locking pin \varnothing 48 (16) is removed.

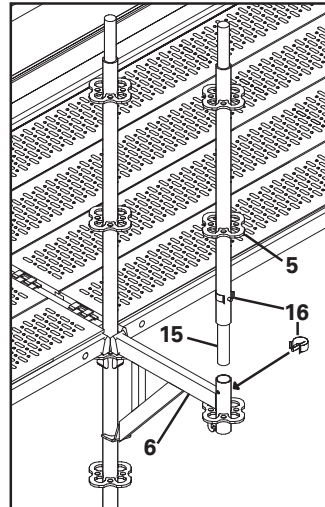

Fig. A5-8

A5.3 Console Brackets UCM and Console Bracket Brace UCM

Fit Console Bracket UCM (6) as previously described.

To fit the Console Bracket Brace UCM (17) insert the spigot into the console bracket tube and then turn the brace until the lug locates under the hook. Then fix the Console Bracket Brace UCM (17) to the vertical Standard UVR (5) using the attached half swivel coupler.

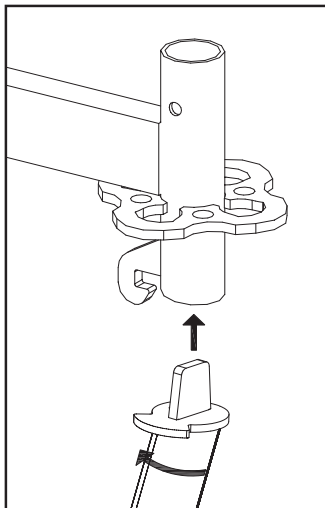

Fig. A5-9

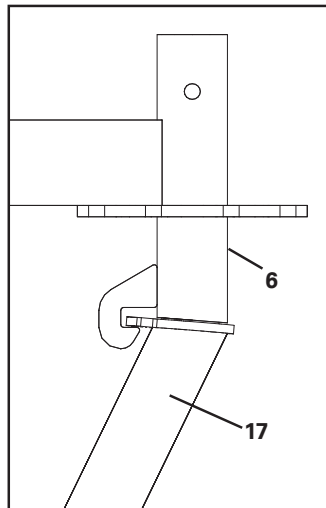

Fig. A5-10

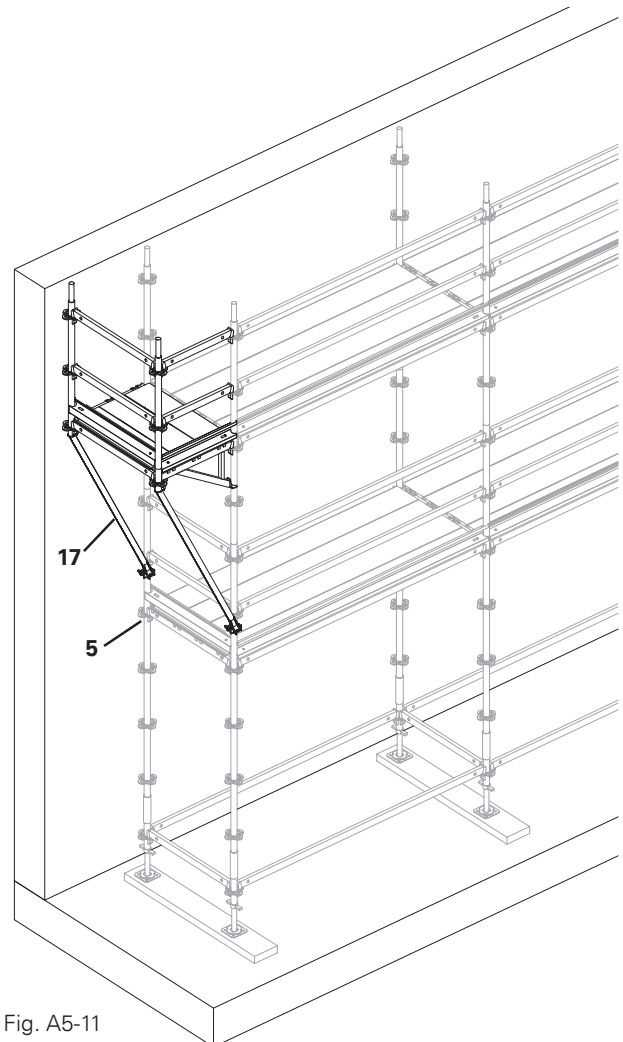

Fig. A5-11

PERI UP Rosett Flex Working Scaffold 100 with Deck UDI

A5 Installing supplementary components

A5.4 Cladding

When using netting or sheeting as cladding, careful attention must be paid to the scaffolding anchorage. The permeability of the netting and the ratio of openings in the structure will determine the number of anchors required (see section B2 Anchor Patterns).

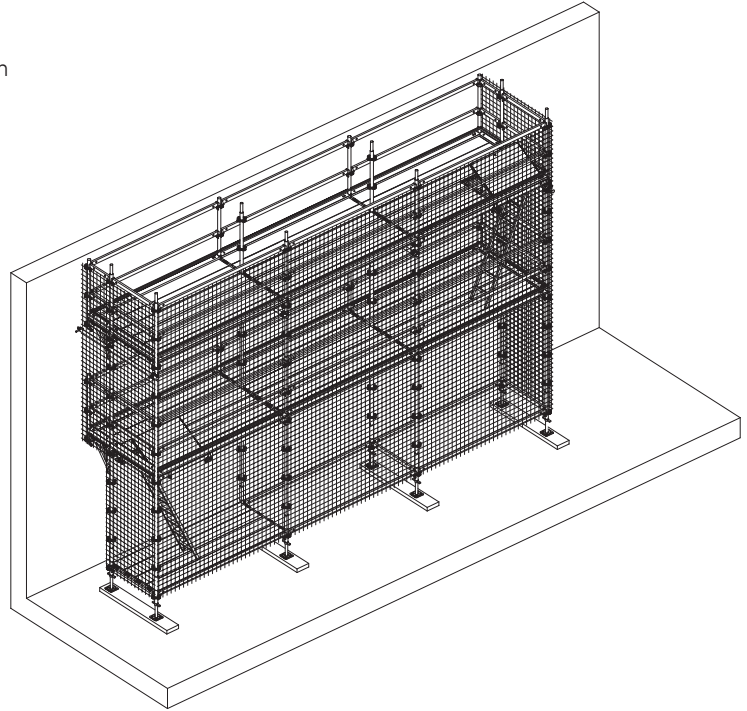

Fig. A5-12

A5.4.1 Covering with nets

The standard configurations shown in section B2 consider netting with the coefficients ($C_{i,\perp} \leq 0.6$ and $C_{i,\parallel} \leq 0.2$). The nets should have eyelets so that they can be fitted to the vertical Standard UVR (5) with ties at centres no greater than 0.5m.

A5.4.2 Covering with closed sheeting

The standard configurations shown in section B2 consider sheeting with the co-efficients ($C_{i,\perp} \leq 1.3$ and $C_{i,\parallel} \leq 0.1$). The closed sheeting should have eyelets so that they can be fitted to the vertical Standard UVR (5) with ties at centres no greater than 0.5m.

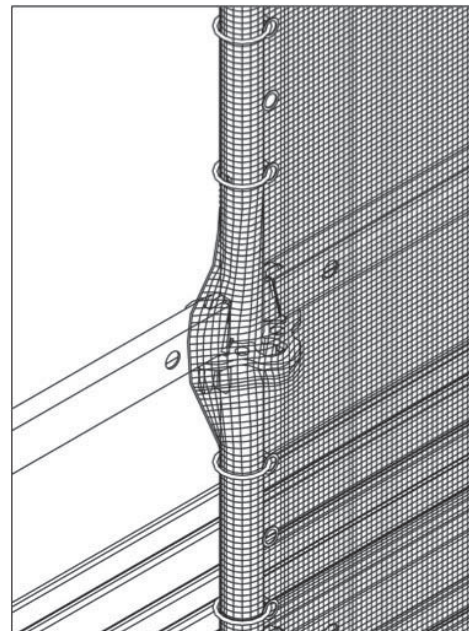

Fig. A5-13

A6 Dismantling

For dismantling, the sequence set out in steps A1 – A3 is reversed. Dismantling takes place bay by bay whilst moving towards the scaffold level access point.

A6.1 UCM edge protection

If applicable, remove Toe Boards UPY (10) from UCM area. Working from behind temporary Ledgers UH (4a), remove the Ledgers UH (4 & 3) and vertical Standards UVR / UVH (5).

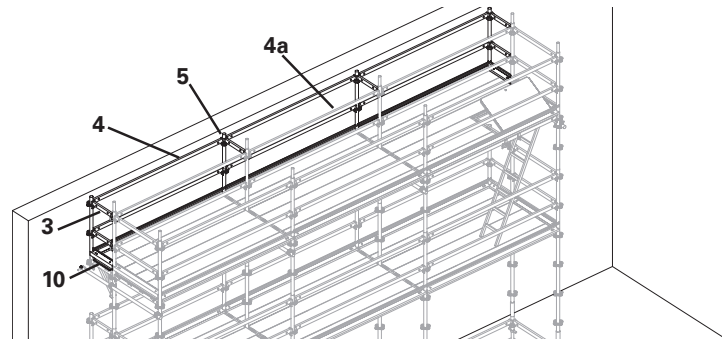

Fig. A6-1

A6.2 Platform edge protection

Remove Toe Boards UPY (10) from end bay and intermediate end Ledger UH 100 Plus (3). Loosen the wedge of the top end Ledger UH 100 Plus (3) on the inside standard so that it is seated in the resting position. Also loosen the wedges of the Ledgers UH (4 & 4a) at the leading edge only. Retreat to the next bay & install temporary Ledger UH 100 Plus (3a), but only fix the wedge to the outer standard. Working from behind temporary Ledgers UH 100 Plus (3a), remove the Ledgers UH (4 & 4a). Remove the last Ledgers UH from the access bay only when leaving that level. Repeat the sequence for all bays.

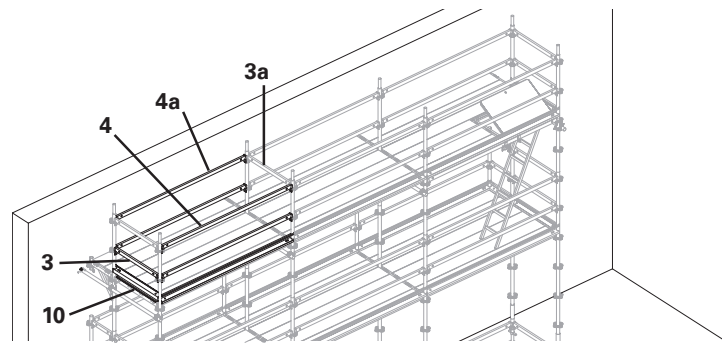

Fig. A6-2

A6.3 Decks UDI & Console Brackets UCM

If applicable, remove the anchors (13) working from the deck below.

Remove the Steel Decks UDI (7), Console Brackets UCM (6), Hatch UAF (11) and deck level Ledgers UH 100 plus (3) & Ledgers UH (4) from below.

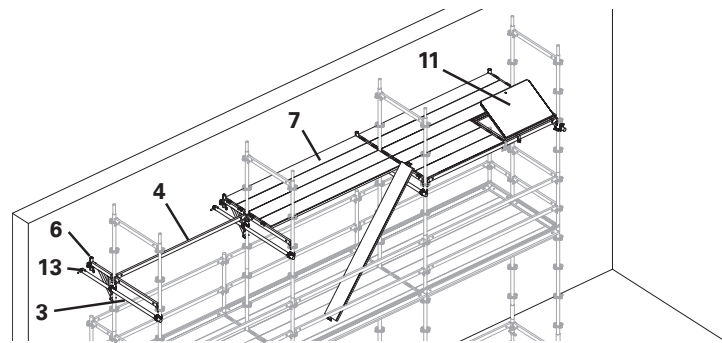

Fig. A6-3

A6.4 Vertical Standards UVR

Remove the outer standards UVR (5) with the Ledgers UH 100 Plus (3a) attached and the inner standards UVR (5)

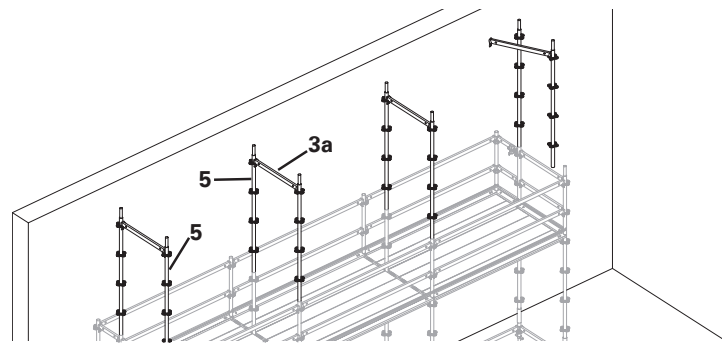

Fig. A6-4

Repeat steps 1-4.

PERI UP Rosett Flex Working Scaffold 100 with Deck UDI

B - Facade Scaffold Standard Configurations

Standard system configurations in accordance with EN 12810-1:2003

Configurations are for max. 24m high scaffolds.

For site specific scaffolds not covered by this document, please contact your local PERI office for more information.

B1 Applied Loadings

The standard configurations are based on the following load data:

B1.1 Platform loadings in accordance with EN 12811-1:2003: 6.2.

- Load Class 1 (LC1) = 0.75kN/m²
- Load Class 2 (LC2) = 1.50kN/m²
- Load Class 3 (LC3) = 2.00kN/m²
- Load Class 4 (LC4) = 3.00kN/m²
- Load Class 5 (LC5) = 4.50kN/m²
- Load Class 6 (LC6) = 6.00kN/m²

The loadings considered in these standard configurations are load class 3 (LC3) and load class 4 (LC4).

B1.2 Applied wind loadings in accordance with EN 12810-1:2003: 8.3. Figure 3.

Max. Wind pressure = 1.1kN/m² at 24m height

B1.3 System Loading Combinations.

PERI UP Rosett Flex					
Loading Combination:	Platform Load Class:	Structure Permeability:	Max. Bay Length:	Scaffold Width:	Max. Console Bracket Size & Position:
A	LC4	Max. 60% open	2.5m	1.0m	0.5m to inside
B	LC3	Max. 60% open	3.0m	1.0m	0.5m to inside
C	LC3	Max. 85% open	2.5m	1.0m	0.5m to inside

Table B1-1

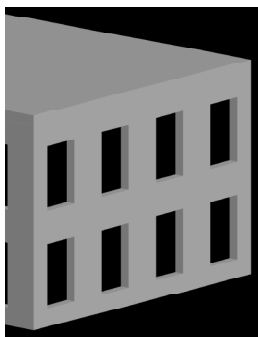

Structure with façade permeability at 60%

Fig. B1-1

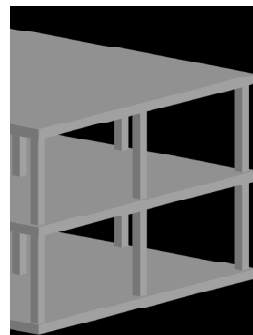

Structure with façade permeability at 85%

Fig. B1-2

PERI UP Rosett Flex Working Scaffold 100 with Deck UDI

B1 Applied Loadings

B1.4 Platform loading data used for standard configurations with load class 4.

Service conditions to EN 12811-1:2003: 6.2.9.2:

B1.4.1 Service condition:

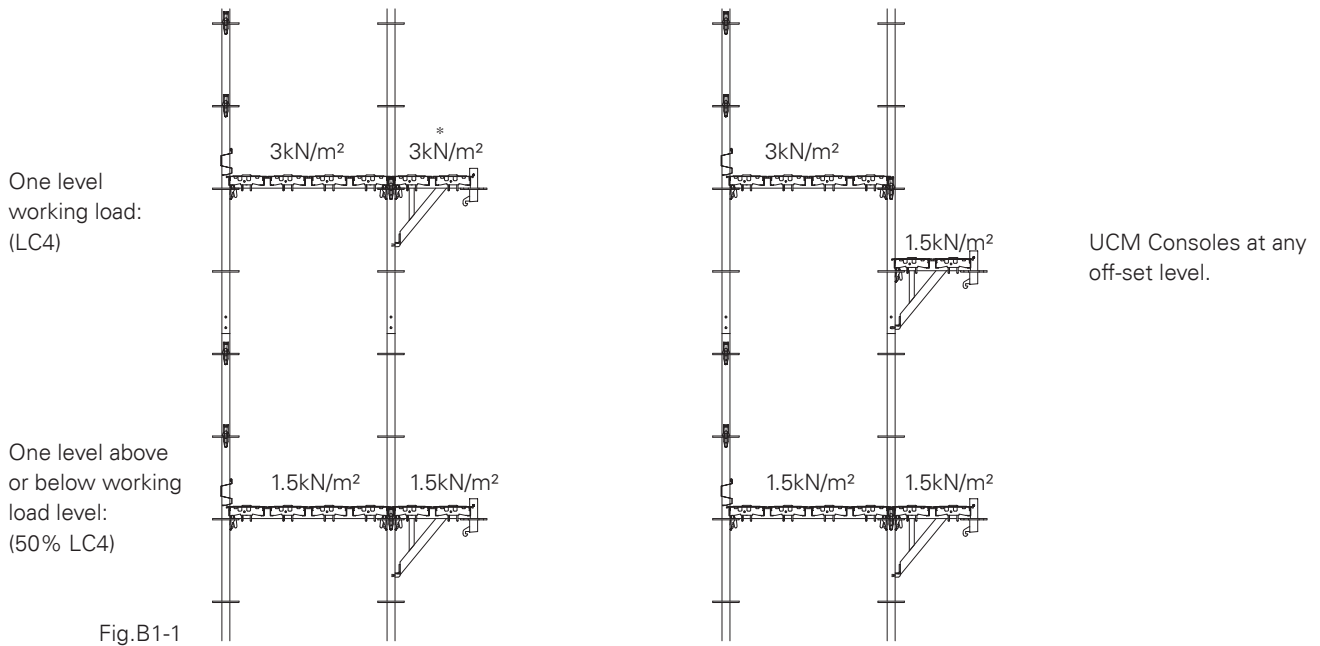

B1.4.2 Out of service condition:

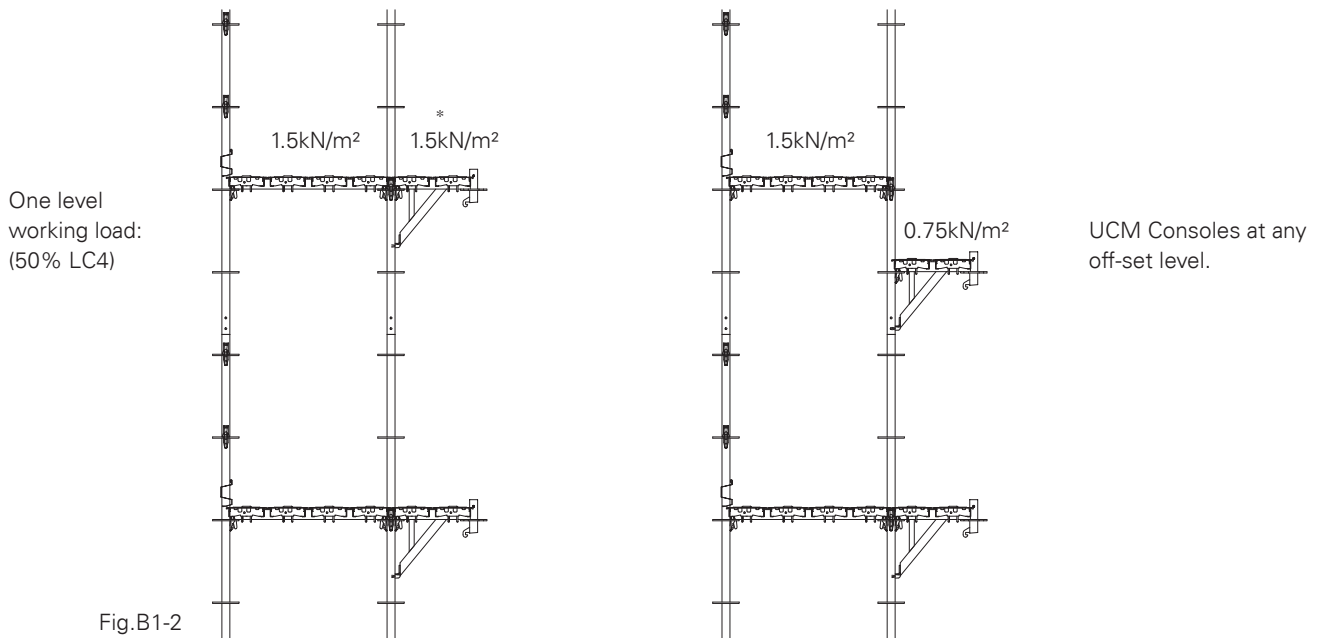

* Console Bracket UCM platforms at main platform levels are capable of supporting the full service load in accordance with EN 12811-1:2003: 6.2.2.5.

PERI UP Rosett Flex Working Scaffold 100 with Deck UDI

B1 Applied Loadings

B1.5 Platform loading data used for standard configurations with load class 3.

Service conditions to EN 12811-1:2003: 6.2.9.2:

B1.5.1 Service condition:

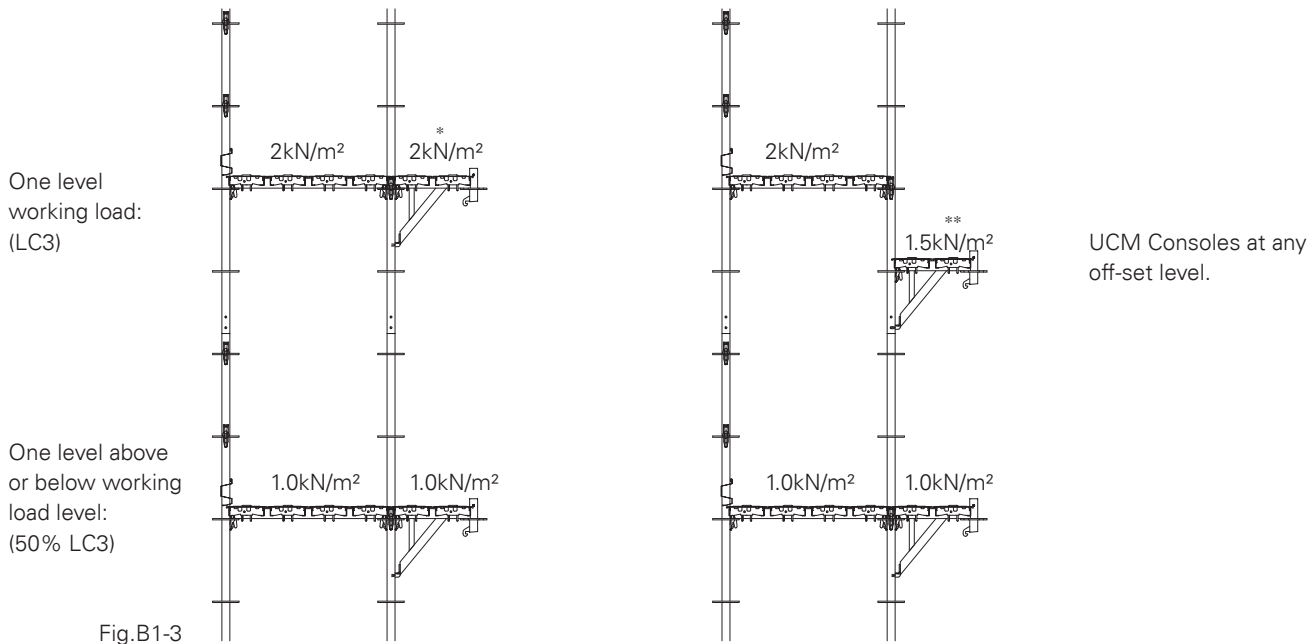

B1.5.2 Out of service condition:

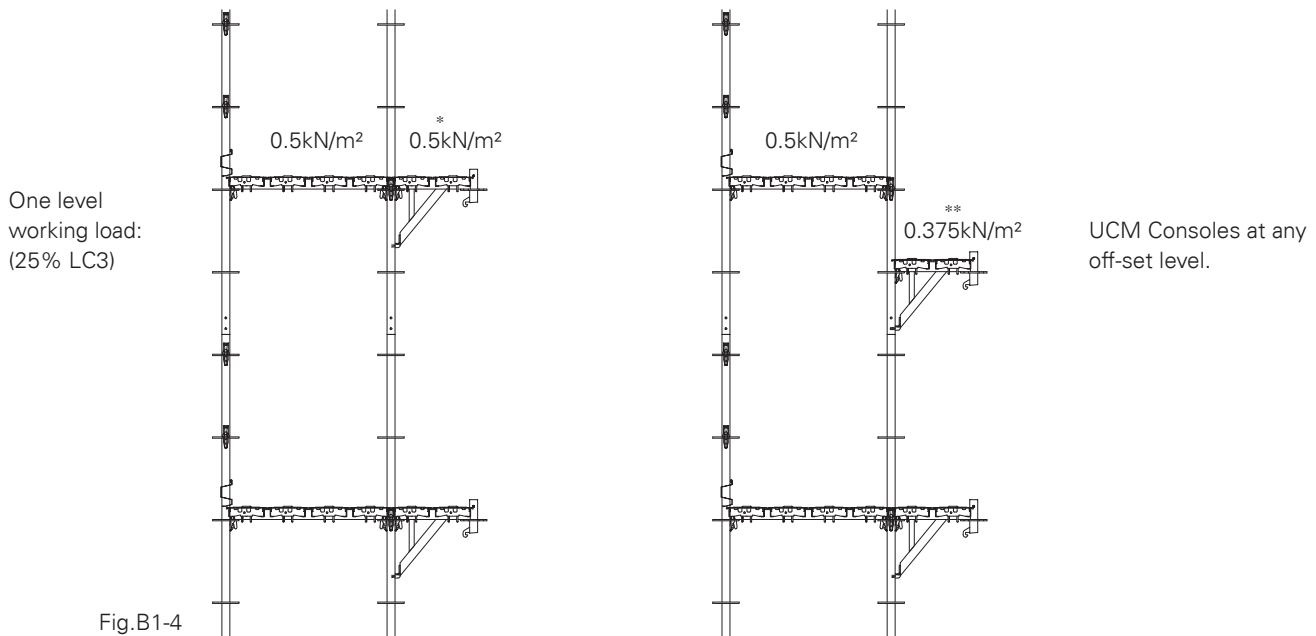

* Console Bracket UCM platforms at main platform levels are capable of supporting the full service load in accordance with EN 12811-1:2003: 6.2.2.5.

** Applied loads to UCM Consoles are higher than required in EN 12811-1:2003: 6.2.9.2.

PERI UP Rosett Flex Working Scaffold 100 with Deck UDI

B2 Anchor Patterns

B2.1 General

The following pages indicate various anchor patterns for PERI-UP Rosett Flex.

The patterns are for different combinations of load cases, bay sizes, structure types, for both unclad scaffolds and clad with netting or closed sheeting.

The diagrams starting on page 29 indicate the anchor type, position and number as well as required ledgers / braces and maximum base jack extension.

B2.2 Anchor pattern options

The choice of anchor pattern depends upon the application as set out in the tables below:

Loading combinations A - C are as set out in Table B1-1.

PERI UP Rosett Flex Loading Combination A – Anchor Patterns			
	Structure		
Cladding Type:	Closed:	Partial open: (≤ 60% open)	Permeable open: (≤ 85% open)
None	A1*, A6*	A1, A6	-
Netting	A2	A3, A7	-
Closed Sheeting	A4	A5	-

Table.B2-1

PERI UP Rosett Flex Loading Combination B – Anchor Patterns			
	Structure		
Cladding Type:	Closed:	Partial open: (≤ 60% open)	Permeable open: (≤ 85% open)
None	B1*, B6*	B1, B6	-
Netting	B2	B3, (B7)	-
Closed Sheeting	B4	B5	-

Table.B2-2

PERI UP Rosett Flex Loading Combination C – Anchor Patterns			
	Structure		
Cladding Type:	Closed:	Partial open: (≤ 60% open)	Permeable open: (≤ 85% open)
None	C1*	C1*	C1
Netting	C2	-	-

Table.B2-3

* Anchor patterns from more open structures may be used.



PERI UP Rosett Flex Working Scaffold 100 with Deck UDI

B2 Anchor Patterns



B2.3 Anchor Variations

Key:

-  Wall tie fixed to both standards
-  Single wall tie fixed to inner standard
-  Triangulated anchors

Triangulated anchors

In anchor patterns A1, A2, A6, A6.1, B1, B2, B6, B6.1, C1 & C2, three wall ties can be replaced by one triangulated tie and two single ties thus:

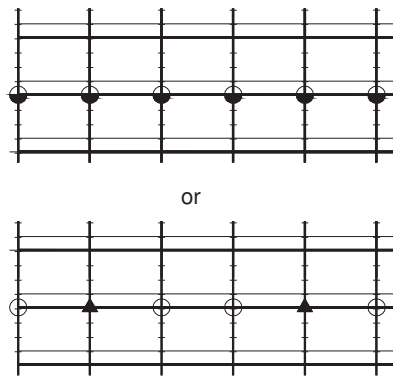

Fig.B2-1

In anchor patterns A3 & B3, three wall ties can be replaced by one triangulated tie and two single ties thus:

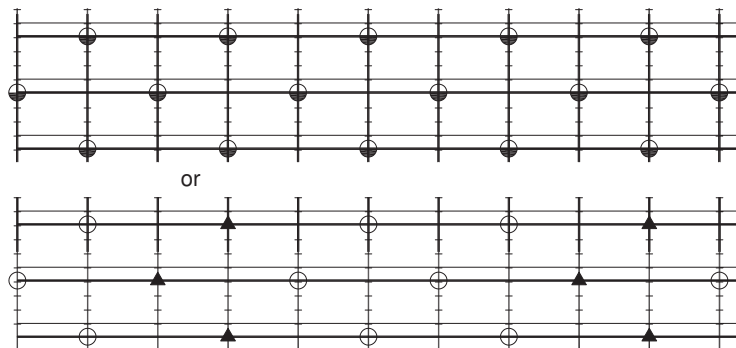

Fig.B2-2

End bays

The following variants are permitted for off set anchors at the end bays:

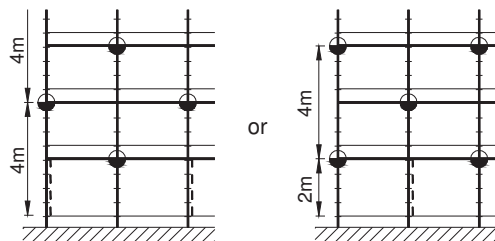

Fig.B2-3

PERI UP Rosett Flex Working Scaffold 100 with Deck UDI B2 Anchor Patterns

B2.4 Basic scaffold arrangement & rules

B2.4.1 System Load Combinations A - C

The anchor patterns are based on scaffolds erected in accordance with the following arrangements:

Note: Only structural components are indicated. All other necessary guard rail ledgers / toe boards omitted for clarity.

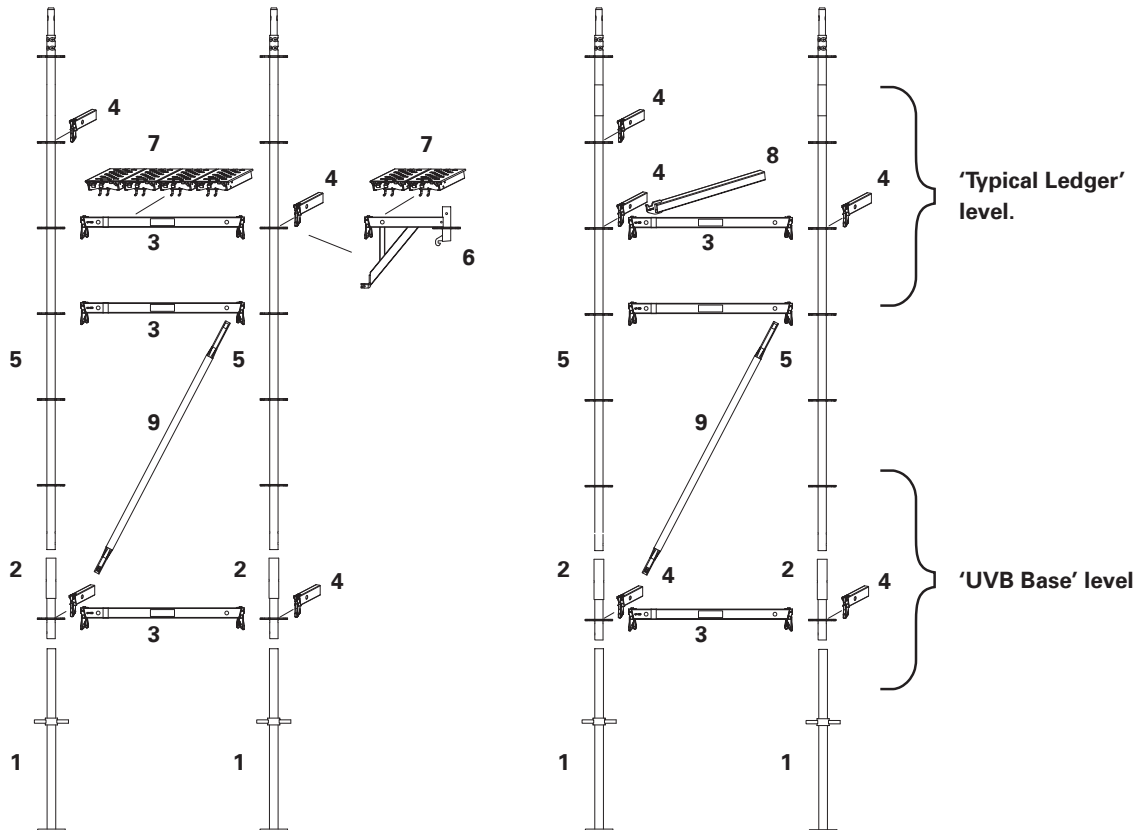

Standard System (UDI Decks at all levels)

No.	Component
1	Adjustable Base Plate UJB 38-80/55
2	Base Standard UVB 24
3	Ledger UH 100 Plus (Item 114632 only!)
4	Longitudinal Ledger UH
5	Standard UVR 300
6	Console Bracket UCM 50-2
7	Longitudinal Industrial Deck UDI 25
8	H-Brace UBH-Flex 250/100
9	Ledger Brace UBL 100/150

Alternative System (UDI Decks at top two levels)

Notes.

- Console Brackets **UCM**'s may be positioned at any level.
- Joints in Standard **UVR**'s may be positioned at any level and may be staggered.
- Maximum 1No. Standard joint permitted per lift per leg.
- 'Typical Ledger' arrangement repeats for all subsequent upper levels.

PERI UP Rosett Flex Working Scaffold 100 with Deck UDI

B2 Anchor Patterns

B2.5.1 Pattern A1

Standard Configuration for scaffold tied to partly open (60%) structure.

Load class to EN 12811-1:	4 (3.0kN/m ²)	Max. base open dimension:	0.595m
Max. bay length:	2.50m	Max. base support reaction:	22.00kN
Max. scaffold width:	1.00m	Max. anchor force A _{II} :	1.64kN
Inside console brackets:	0.50m	Max. anchor force A _I :	1.55kN
UDI decks:	All levels (except base)		
Scaffold façade:	No sheeting or netting		

* Components not required for scaffolds with bay length ≤ 2.0m or height h ≤ 16m

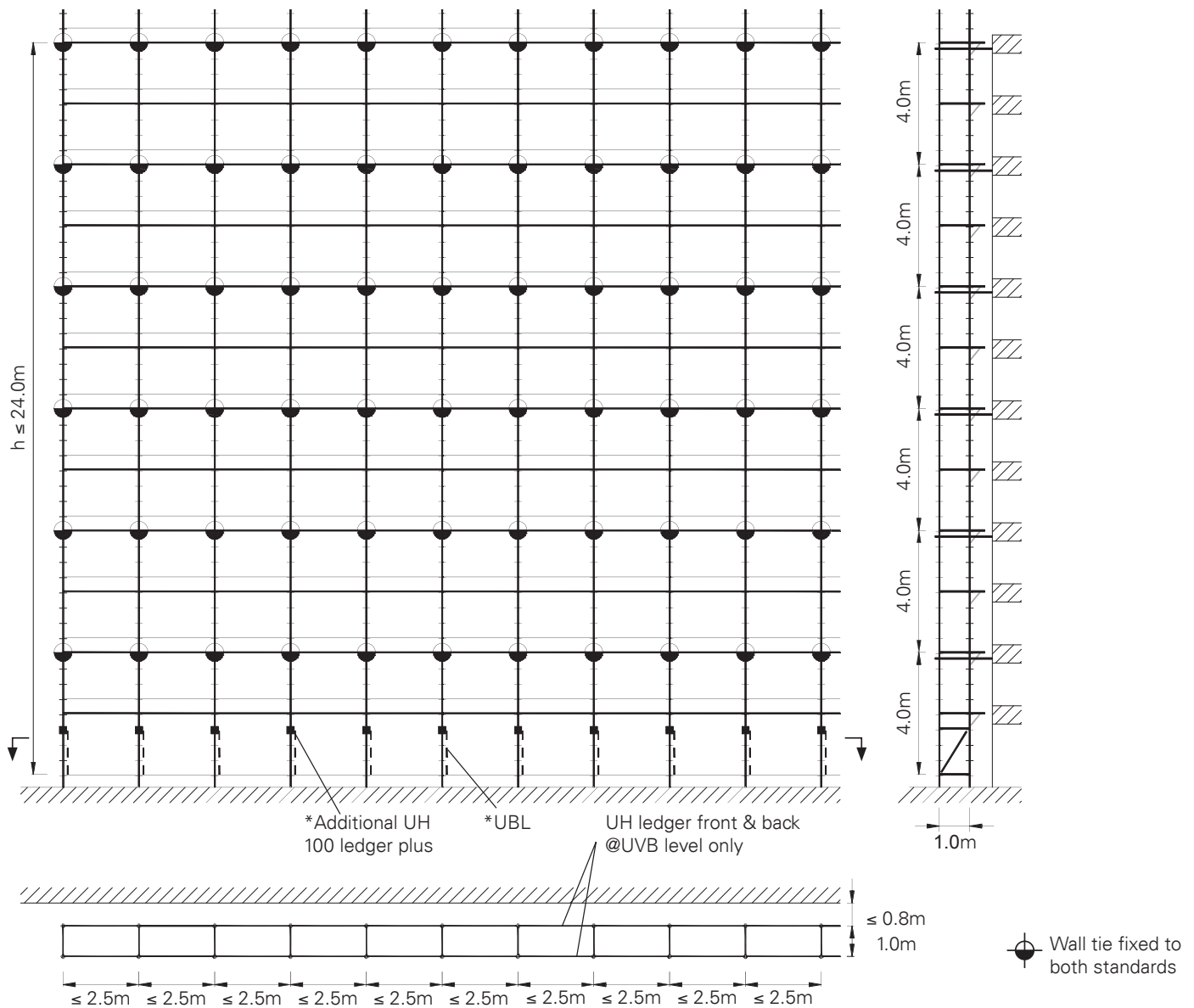

Note: Only structural components are indicated. All other necessary guard rail ledgers / toe boards omitted for clarity. Façade bracing is not required.

PERI UP Rosett Flex Working Scaffold 100 with Deck UDI B2 Anchor Patterns



B2.5.2 Pattern A2

Standard Configuration for netted scaffold tied to closed structure.

Load class to EN 12811-1:	4 (3.0kN/m ²)	Max. base open dimension:	0.595m
Max. bay length:	2.50m	Max. base support reaction:	22.00kN
Max. scaffold width:	1.00m	Max. anchor force A _{II} :	1.55kN
Inside console brackets:	0.50m	Max. anchor force A _I :	1.10kN
UDI decks:	All levels (except base)		
Scaffold façade:	Netting		

* Components not required for scaffolds with bay length ≤ 2.0m or height h ≤ 16m

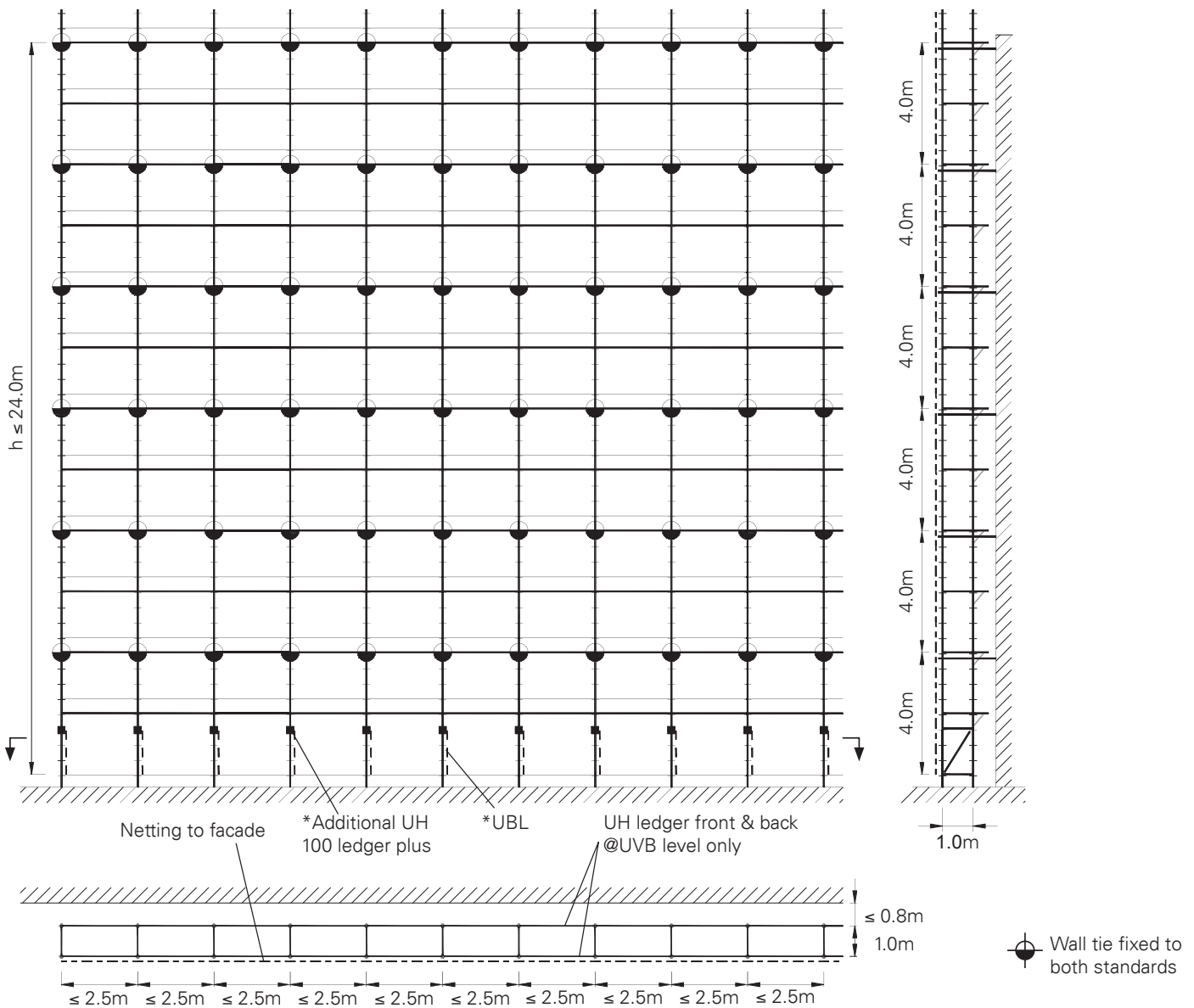

Note: Only structural components are indicated. All other necessary guard rail ledgers / toe boards omitted for clarity. Façade bracing is not required.

PERI UP Rosett Flex Working Scaffold 100 with Deck UDI B2 Anchor Patterns



B2.5.3 Pattern A3

Standard Configuration for netted scaffold tied to partly open (60%) structure.

Load class to EN 12811-1:	4 (3.0kN/m ²)	Max. base open dimension:	0.595m
Max. bay length:	2.50m	Max. base support reaction:	22.00kN
Max. scaffold width:	1.00m	Max. anchor force A _{II} :	1.42kN
Inside console brackets:	0.50m	Max. anchor force A _I :	3.39kN
UDI decks:	All levels (except base)		
Scaffold façade:	Netting		

* Components not required for scaffolds with bay length ≤ 2.0m or height h ≤ 16m

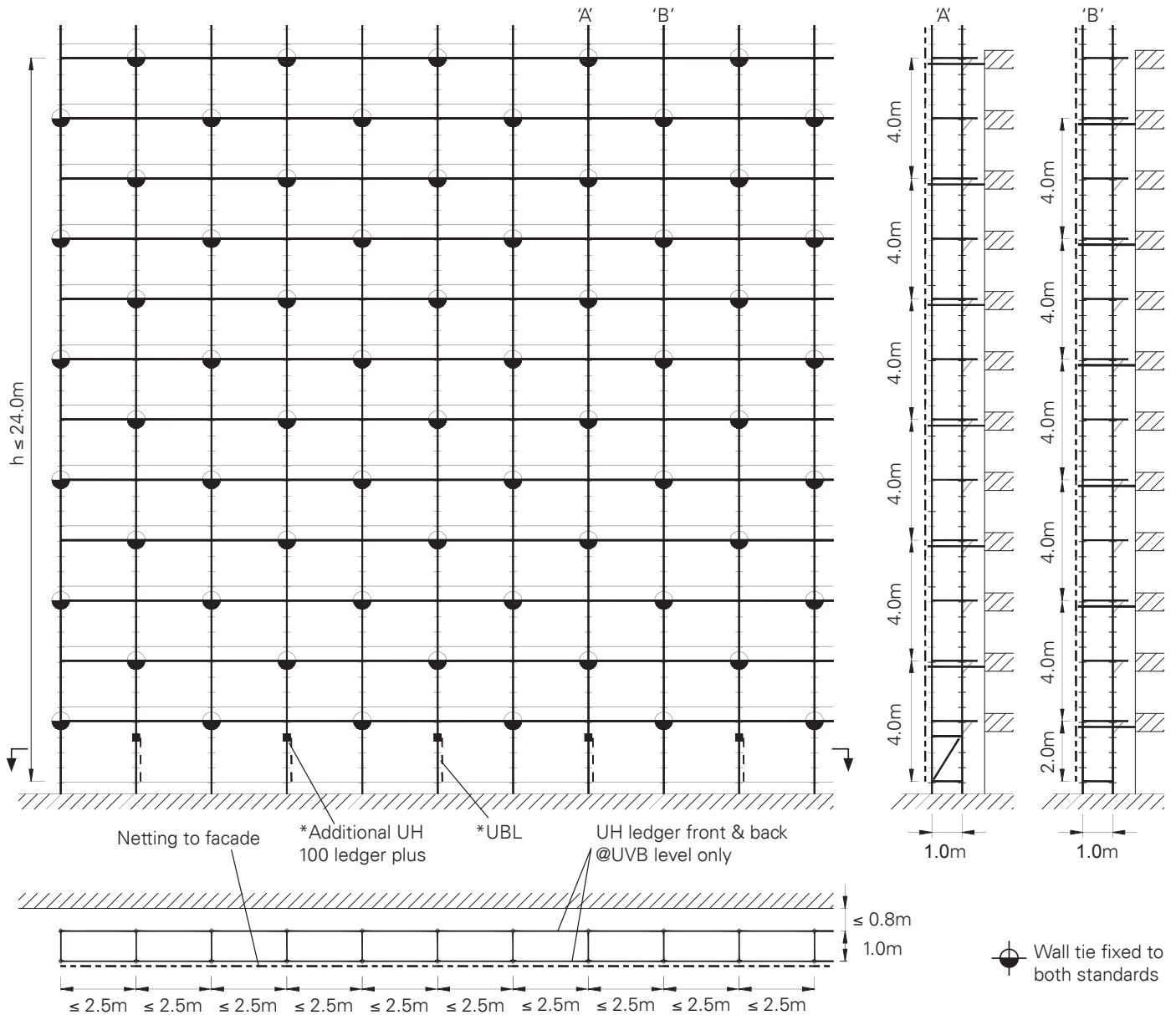

Note: Only structural components are indicated. All other necessary guard rail ledgers / toe boards omitted for clarity. Façade bracing is not required.

PERI UP Rosett Flex Working Scaffold 100 with Deck UDI B2 Anchor Patterns



B2.5.3.1 Pattern A3.1 Variation 1 (Lowest anchor at 4m)

Standard Configuration for netted scaffold tied to partly open (60%) structure.

Load class to EN 12811-1:	4 (3.0kN/m ²)	Max. base open dimension:	0.595m
Max. bay length:	2.50m	Max. base support reaction:	22.00kN
Max. scaffold width:	1.00m	Max. anchor force A :	1.42kN
Inside console brackets:	0.50m	Max. anchor force A _⊥ :	3.39kN
UDI decks:	All levels (except base)		
Scaffold façade:	Netting		

* Components not required for scaffolds with bay length ≤ 2.0m or height h ≤ 16m

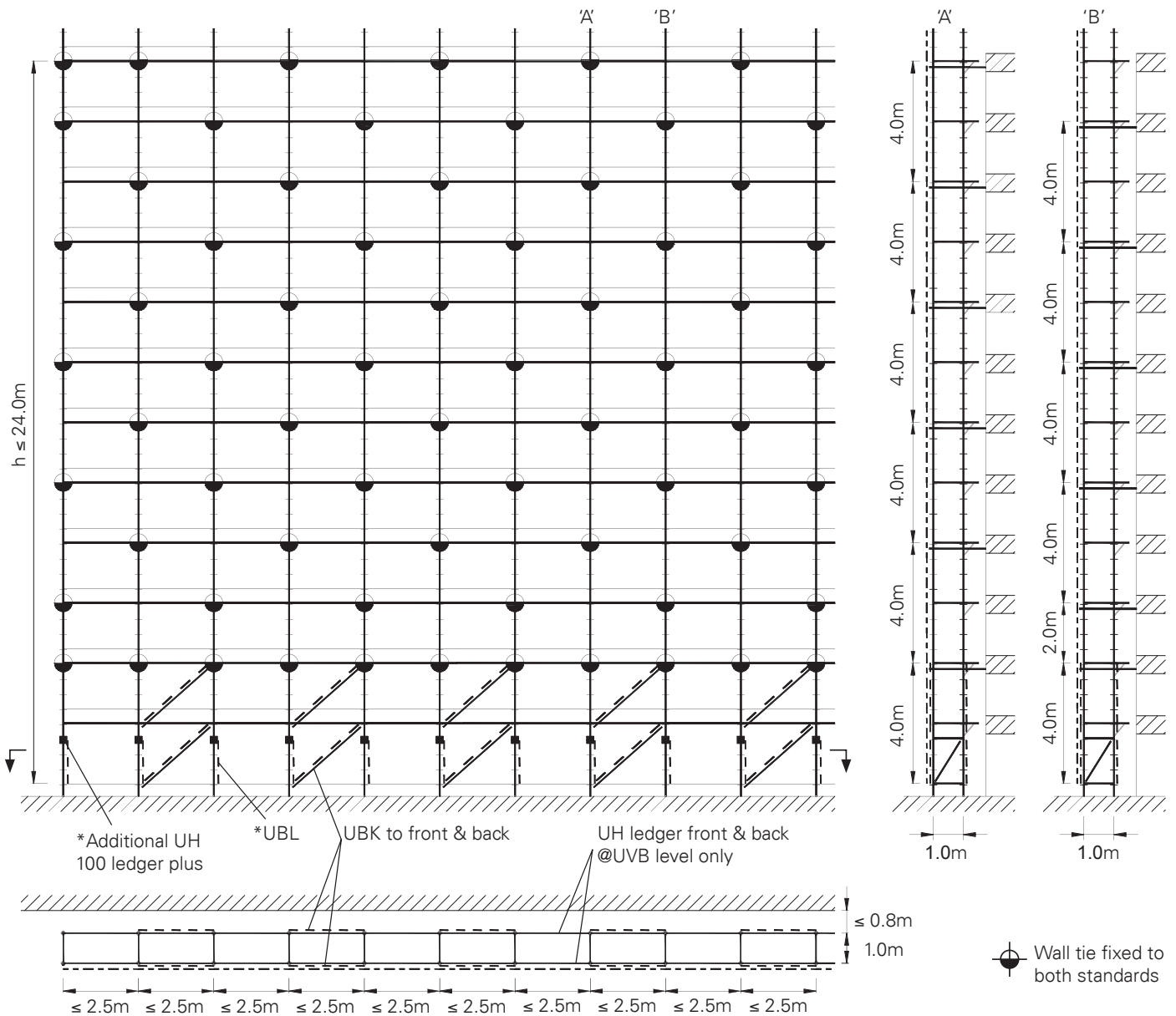

Note: Only structural components are indicated. All other necessary guard rail ledgers / toe boards omitted for clarity. Façade bracing is not required above bottom wall ties.

PERI UP Rosett Flex Working Scaffold 100 with Deck UDI B2 Anchor Patterns



B2.5.5 Pattern A5

Standard Configuration for sheeted scaffold tied to partly open (60%) structure.

Load class to EN 12811-1:	4 (3.0kN/m ²)	Max. base open dimension:	0.595m
Max. bay length:	2.50m	Max. base support reaction:	22.00kN
Max. scaffold width:	1.00m	Max. anchor force A _{II} :	1.67kN
Inside console brackets:	0.50m	Max. anchor force A _I :	4.89kN
UDI decks:	All levels (except base)		
Scaffold façade:	Closed sheeting		

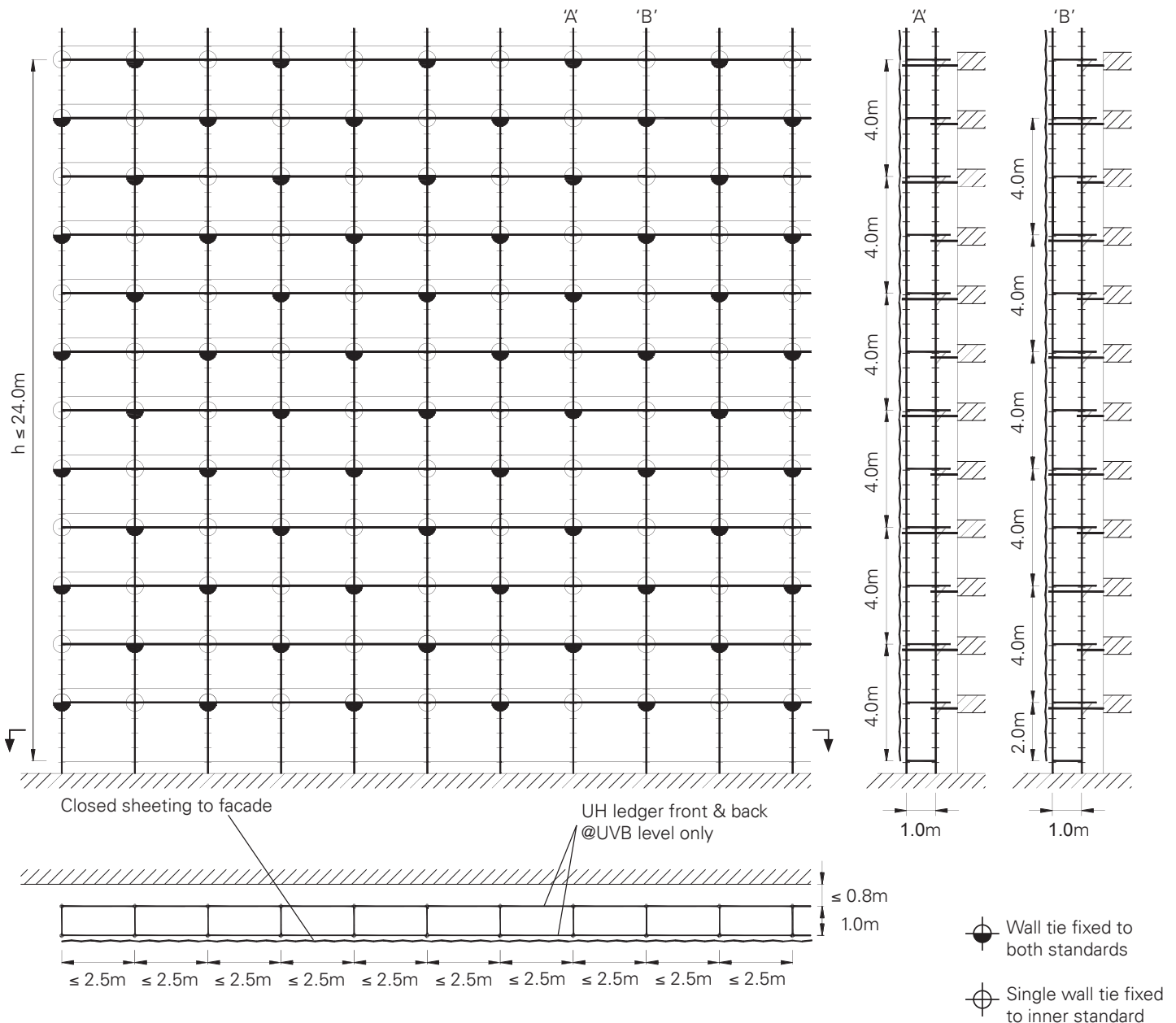

Note: Only structural components are indicated. All other necessary guard rail ledgers / toe boards omitted for clarity.
Façade bracing is not required.

PERI UP Rosett Flex Working Scaffold 100 with Deck UDI B2 Anchor Patterns



B2.5.6 Pattern A6

Standard Configuration for scaffold tied to partly open (60%) structure.

Load class to EN 12811-1:	4 (3.0kN/m ²)	Max. base open dimension:	0.595m
Max. bay length:	2.50m	Max. base support reaction:	12.00kN
Max. scaffold width:	1.00m	Max. anchor force A _{II} :	1.64kN
Inside console brackets:	0.50m	Max. anchor force A _I :	1.55kN
UDI decks:	Top 2 levels	* Components not required for scaffolds with bay length ≤ 2.0m or height h ≤ 16m	
Scaffold façade:	No sheeting or netting		

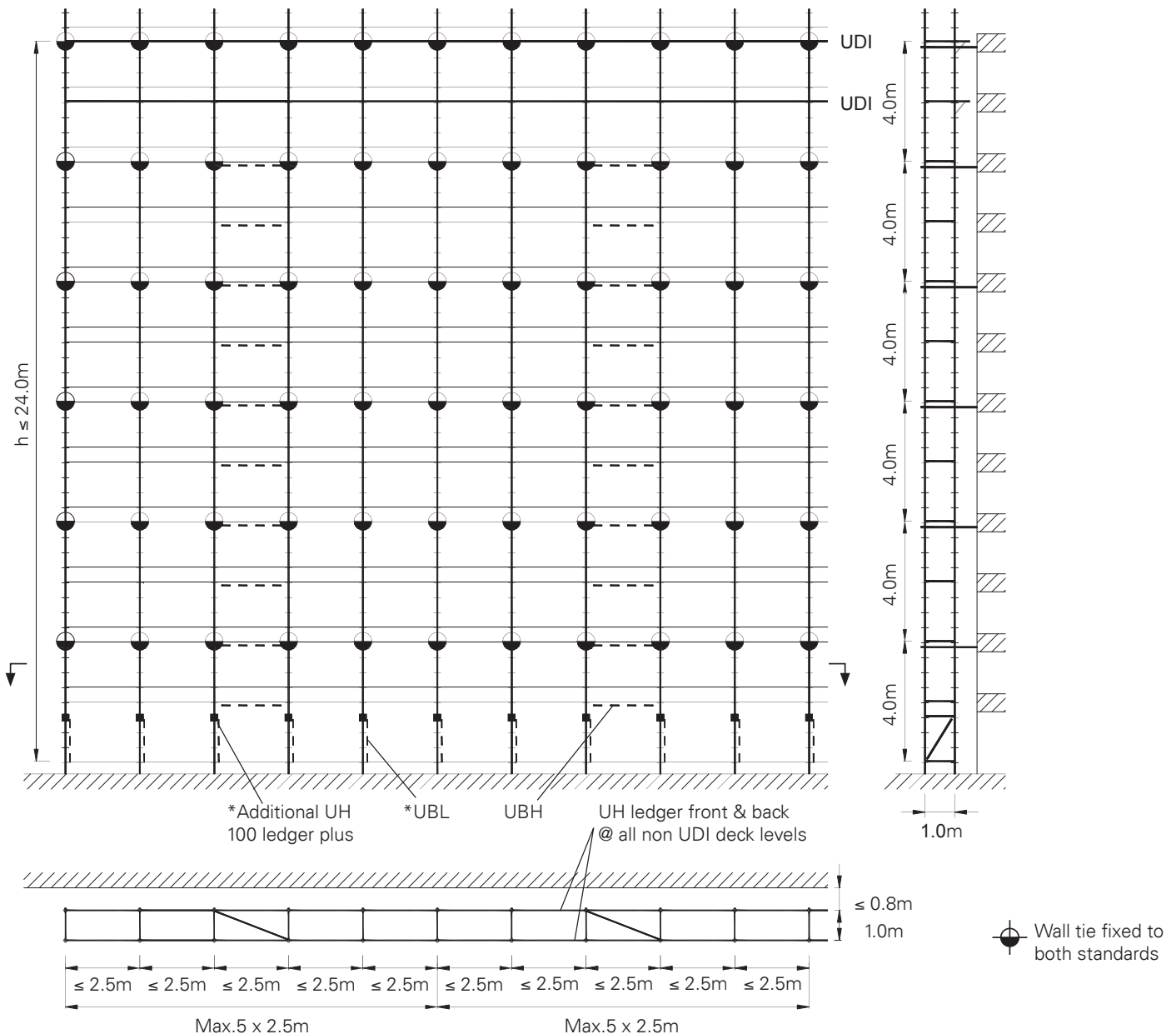

Note: Only structural components are indicated. All other necessary guard rail ledgers / toe boards omitted for clarity. Façade bracing is not required.

PERI UP Rosett Flex Working Scaffold 100 with Deck UDI

B2 Anchor Patterns



B2.5.6.1 Pattern A6.1 Variation 1 (Façade bracing)

Standard Configuration for scaffold tied to partly open (60%) structure.

Load class to EN 12811-1:	4 (3.0kN/m ²)	Max. base open dimension:	0.595m
Max. bay length:	2.50m	Max. base support reaction:	12.00kN
Max. scaffold width:	1.00m	Max. anchor force A _{II} :	1.64kN
Inside console brackets:	0.50m	Max. anchor force A _I :	1.55kN
UDI decks:	Top 2 levels	* Components not required for scaffolds with bay length ≤ 2.0m or height h ≤ 16m	
Scaffold façade:	No sheeting or netting		

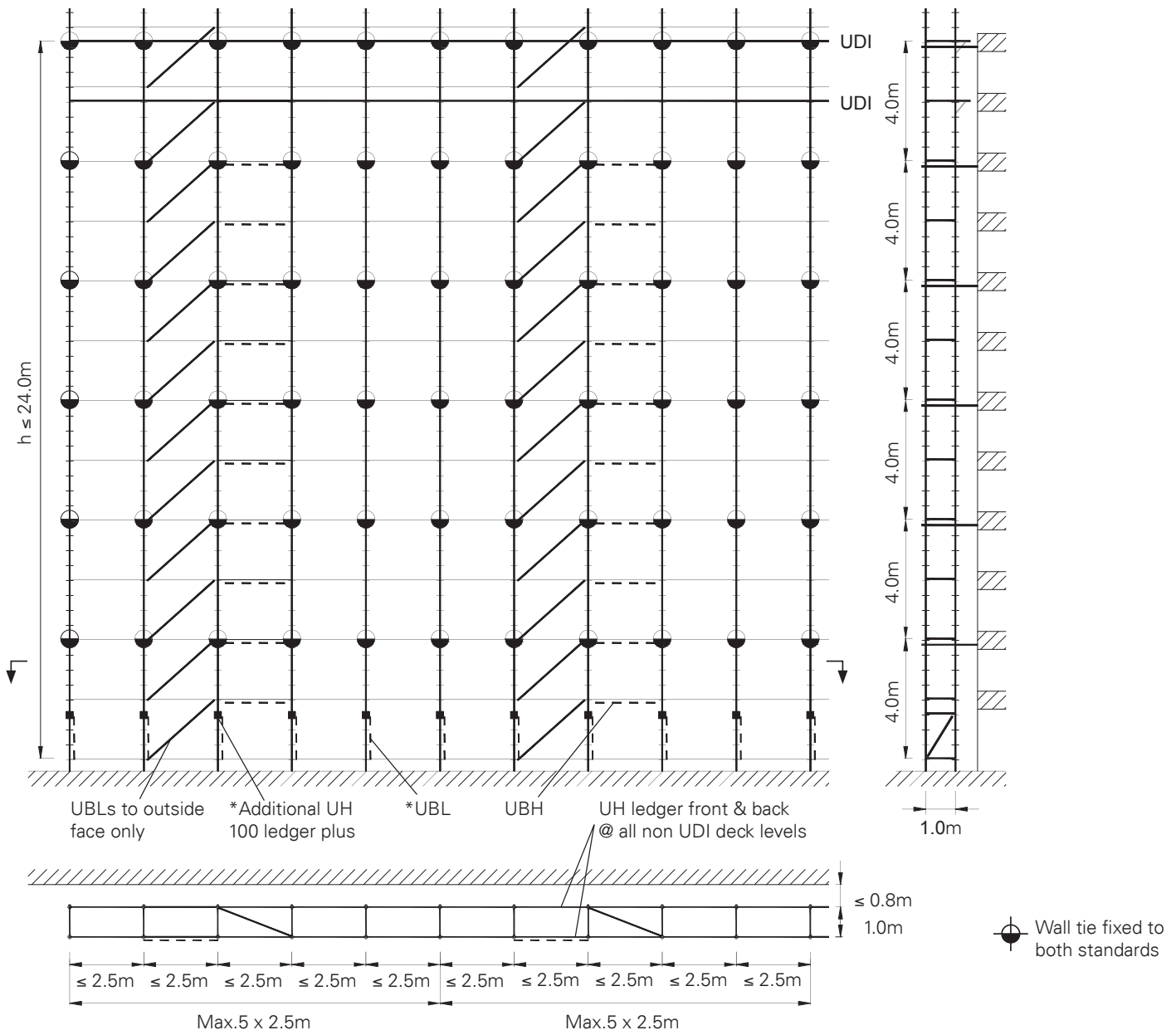

Note: Only structural components are indicated. All other necessary guard rail ledgers / toe boards omitted for clarity.
Façade bracing replaces intermediate Ledgers UH.

PERI UP Rosett Flex Working Scaffold 100 with Deck UDI B2 Anchor Patterns



B2.5.7 Pattern A7

Standard Configuration for netted scaffold tied to partly open (60%) structure.

Load class to EN 12811-1:	4 (3.0kN/m ²)	Max. base open dimension:	0.595m
Max. bay length:	2.50m	Max. base support reaction:	12.00kN
Max. scaffold width:	1.00m	Max. anchor force A _{II} :	1.42kN
Inside console brackets:	0.50m	Max. anchor force A _I :	3.39kN
UDI decks:	Top 2 levels		
Scaffold façade:	Netting		

* Components not required for scaffolds with bay length ≤ 2.0m or height h ≤ 16m

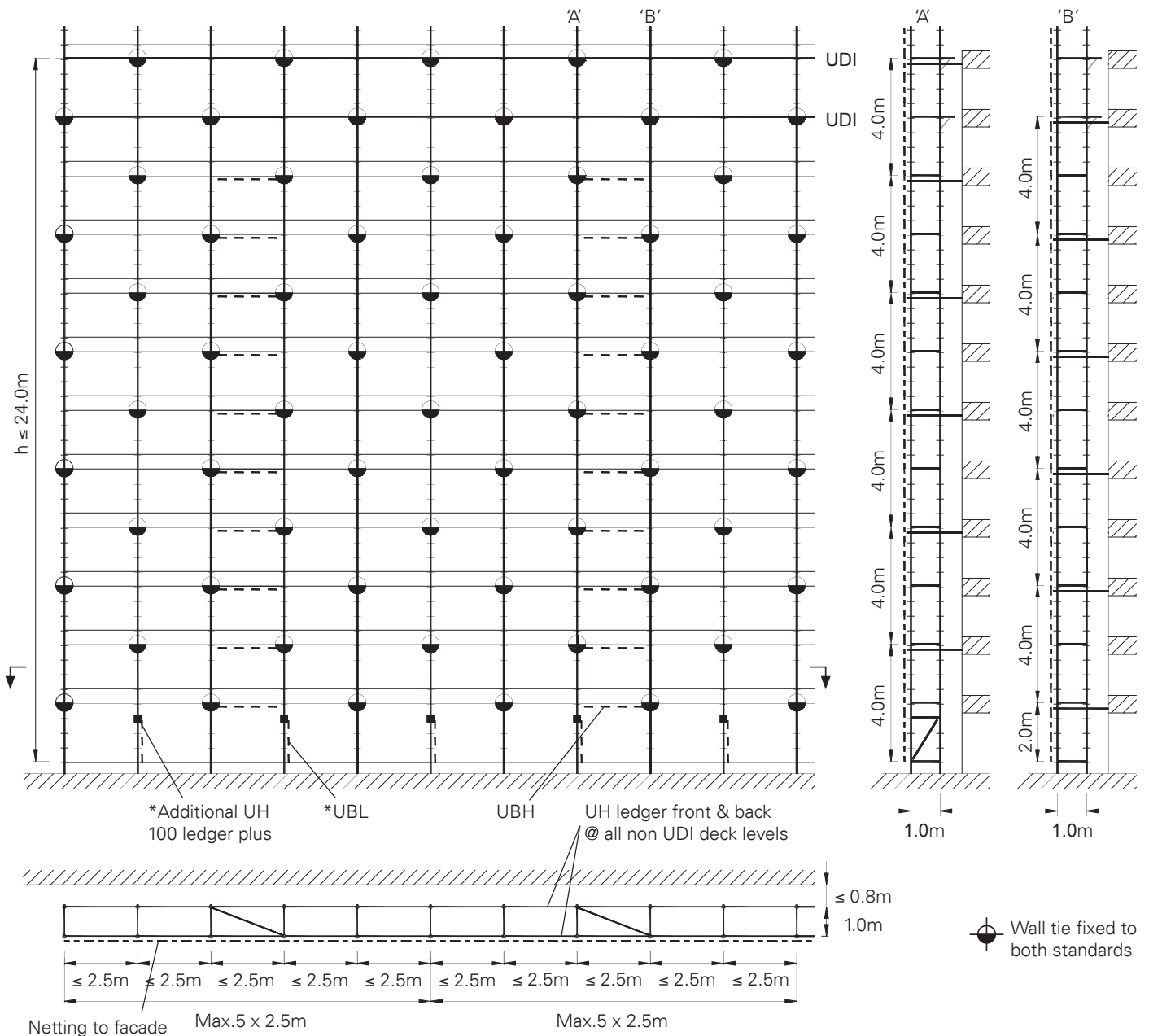

Note: Only structural components are indicated. All other necessary guard rail ledgers / toe boards omitted for clarity. Façade bracing is not required.

PERI UP Rosett Flex Working Scaffold 100 with Deck UDI B2 Anchor Patterns



B2.5.7.1 Pattern A7.1 Variation 1 (Lowest anchor at 4m)

Standard Configuration for netted scaffold tied to partly open (60%) structure.

Load class to EN 12811-1:	4 (3.0kN/m ²)	Max. base open dimension:	0.595m
Max. bay length:	2.50m	Max. base support reaction:	12.00kN
Max. scaffold width:	1.00m	Max. anchor force A :	1.42kN
Inside console brackets:	0.50m	Max. anchor force A _⊥ :	3.39kN
UDI decks:	Top 2 levels		
Scaffold façade:	Netting		

* Components not required for scaffolds with bay length ≤ 2.0m or height h ≤ 16m

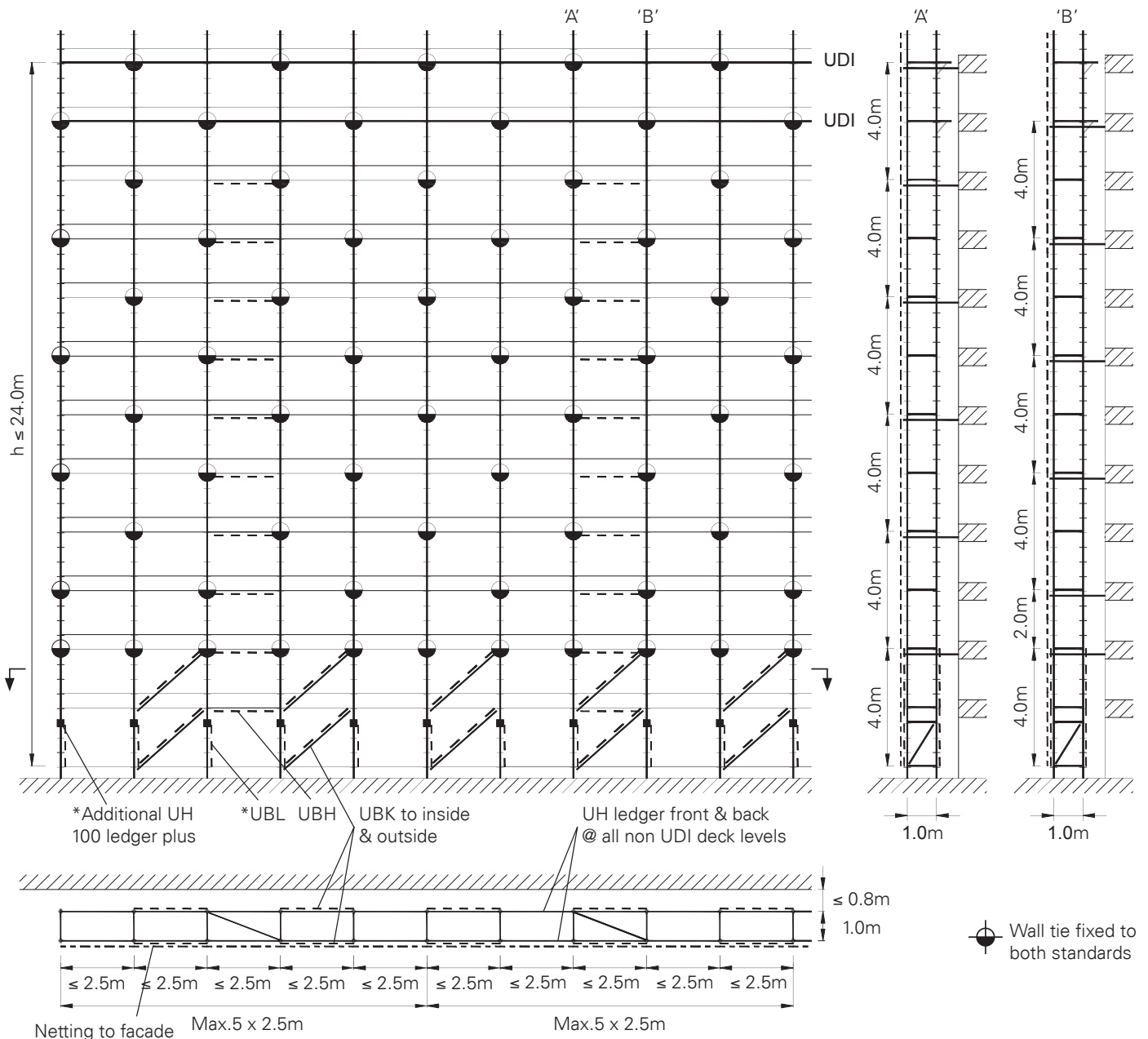

Note: Only structural components are indicated. All other necessary guard rail ledgers / toe boards omitted for clarity. Façade bracing is not required above bottom wall ties.

PERI UP Rosett Flex Working Scaffold 100 with Deck UDI B2 Anchor Patterns



B2.6.1 Pattern B1

Standard Configuration for scaffold tied to partly open (60%) structure.

Load class to EN 12811-1:	3 (2.0kN/m ²)	Max. base open dimension:	0.595m
Max. bay length:	3.00m	Max. base support reaction:	21.70kN
Max. scaffold width:	1.00m	Max. anchor force A _{II} :	1.64kN
Inside console brackets:	0.50m	Max. anchor force A _I :	1.81kN
UDI decks:	All levels (except base)		
Scaffold façade:	No sheeting or netting		

* Components not required for scaffolds with bay length ≤ 2.5m or height h ≤ 20m

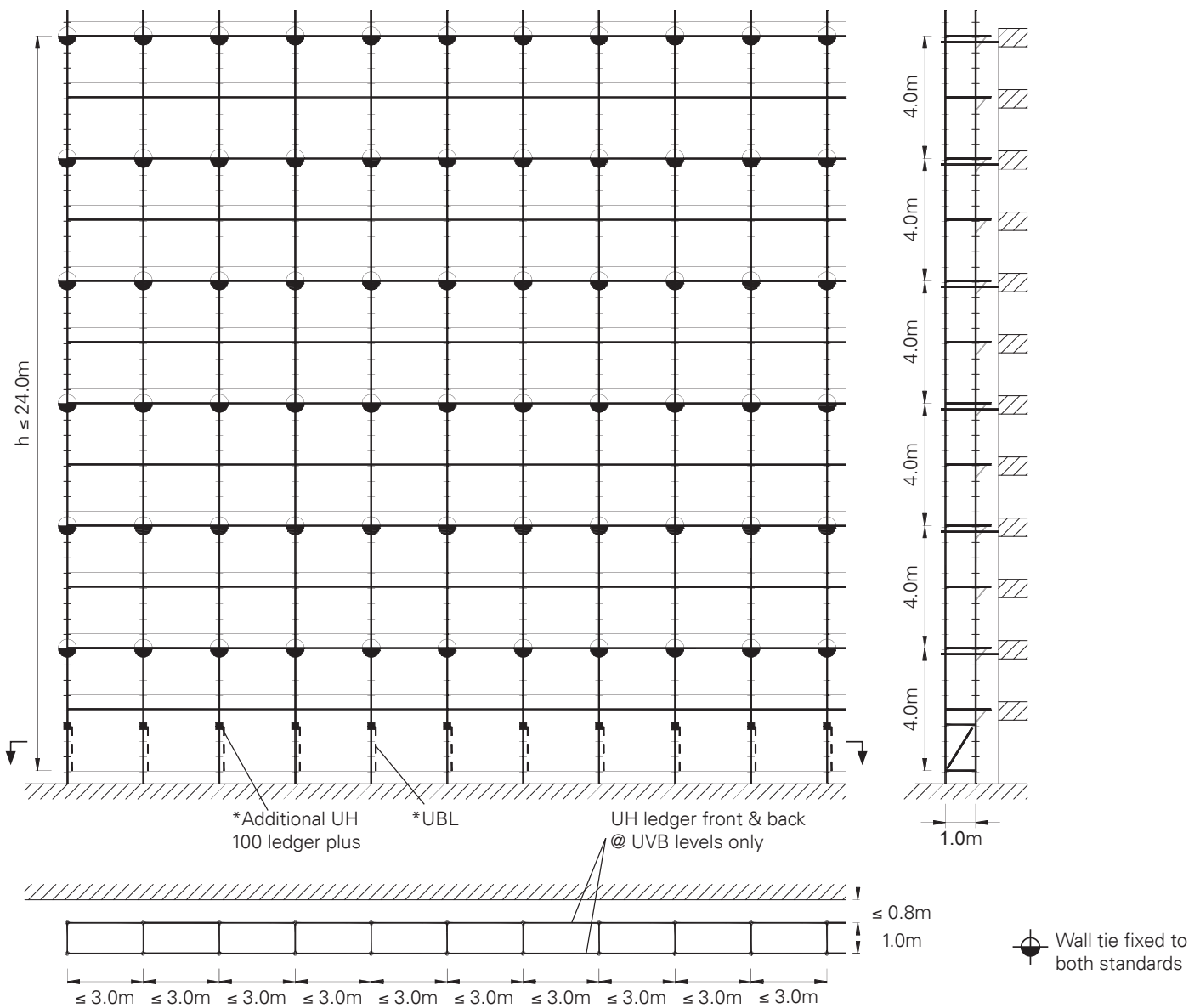

Note: Only structural components are indicated. All other necessary guard rail ledgers / toe boards omitted for clarity.
Façade bracing is not required.

PERI UP Rosett Flex Working Scaffold 100 with Deck UDI B2 Anchor Patterns



B2.6.2 Pattern B2

Standard Configuration for netted scaffold tied to closed structure.

Load class to EN 12811-1:	3 (2.0kN/m ²)	Max. base open dimension:	0.595m
Max. bay length:	3.00m	Max. base support reaction:	21.70kN
Max. scaffold width:	1.00m	Max. anchor force A _{II} :	1.68kN
Inside console brackets:	0.50m	Max. anchor force A _I :	1.32kN
UDI decks:	All levels (except base)		
Scaffold façade:	Netting		

* Components not required for scaffolds with bay length ≤ 2.5m or height h ≤ 20m

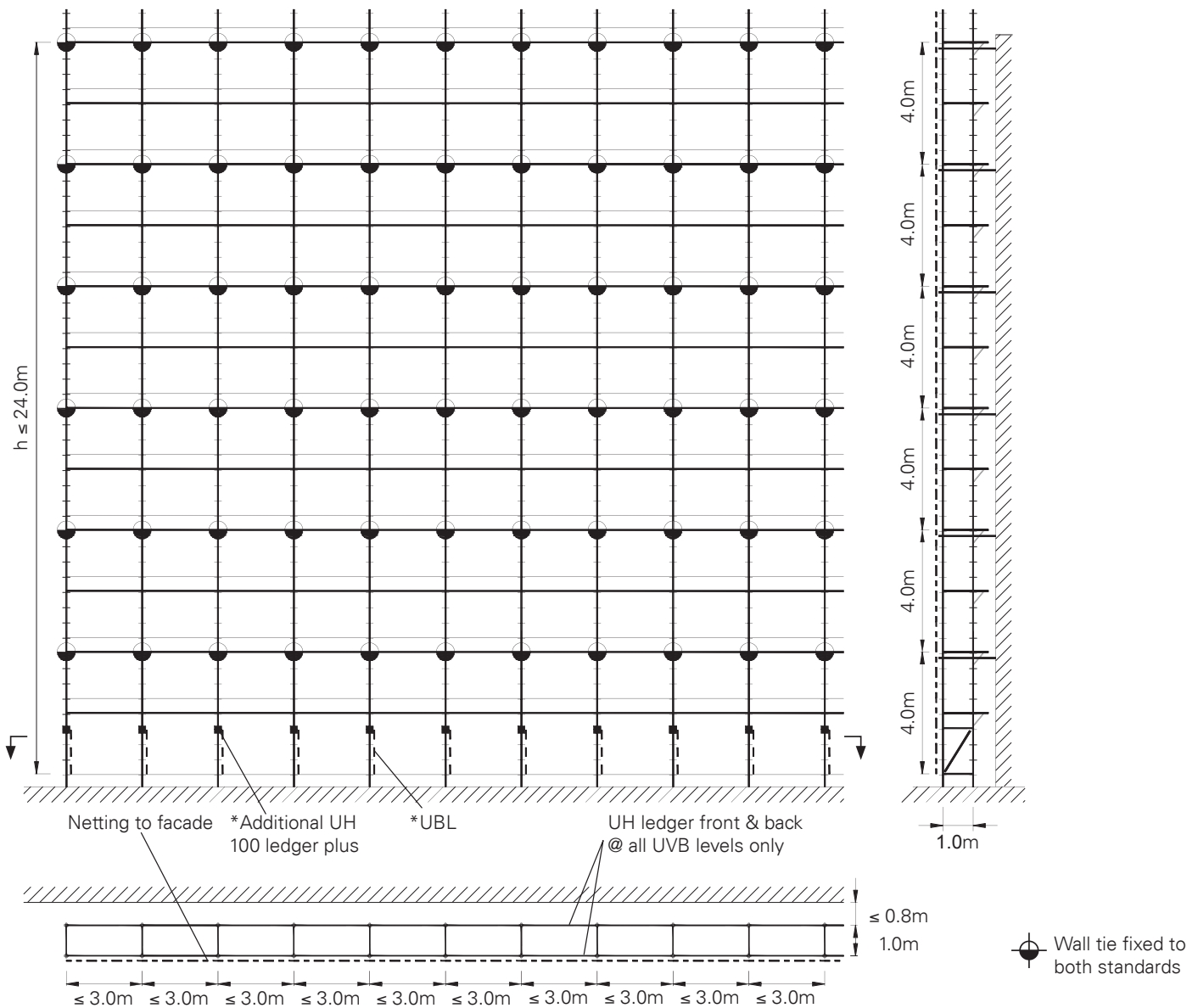

Note: Only structural components are indicated. All other necessary guard rail ledgers / toe boards omitted for clarity. Façade bracing is not required.

PERI UP Rosett Flex Working Scaffold 100 with Deck UDI B2 Anchor Patterns



B2.6.3 Pattern B3

Standard Configuration for netted scaffold tied to partly open (60%) structure.

Load class to EN 12811-1:	3 (2.0kN/m ²)	Max. base open dimension:	0.595m
Max. bay length:	3.00m	Max. base support reaction:	21.70kN
Max. scaffold width:	1.00m	Max. anchor force A _{II} :	1.61kN
Inside console brackets:	0.50m	Max. anchor force A _I :	4.06kN
UDI decks:	All levels (except base)		
Scaffold façade:	Netting		

* Components not required for scaffolds with bay length ≤ 2.5m or height h ≤ 20m

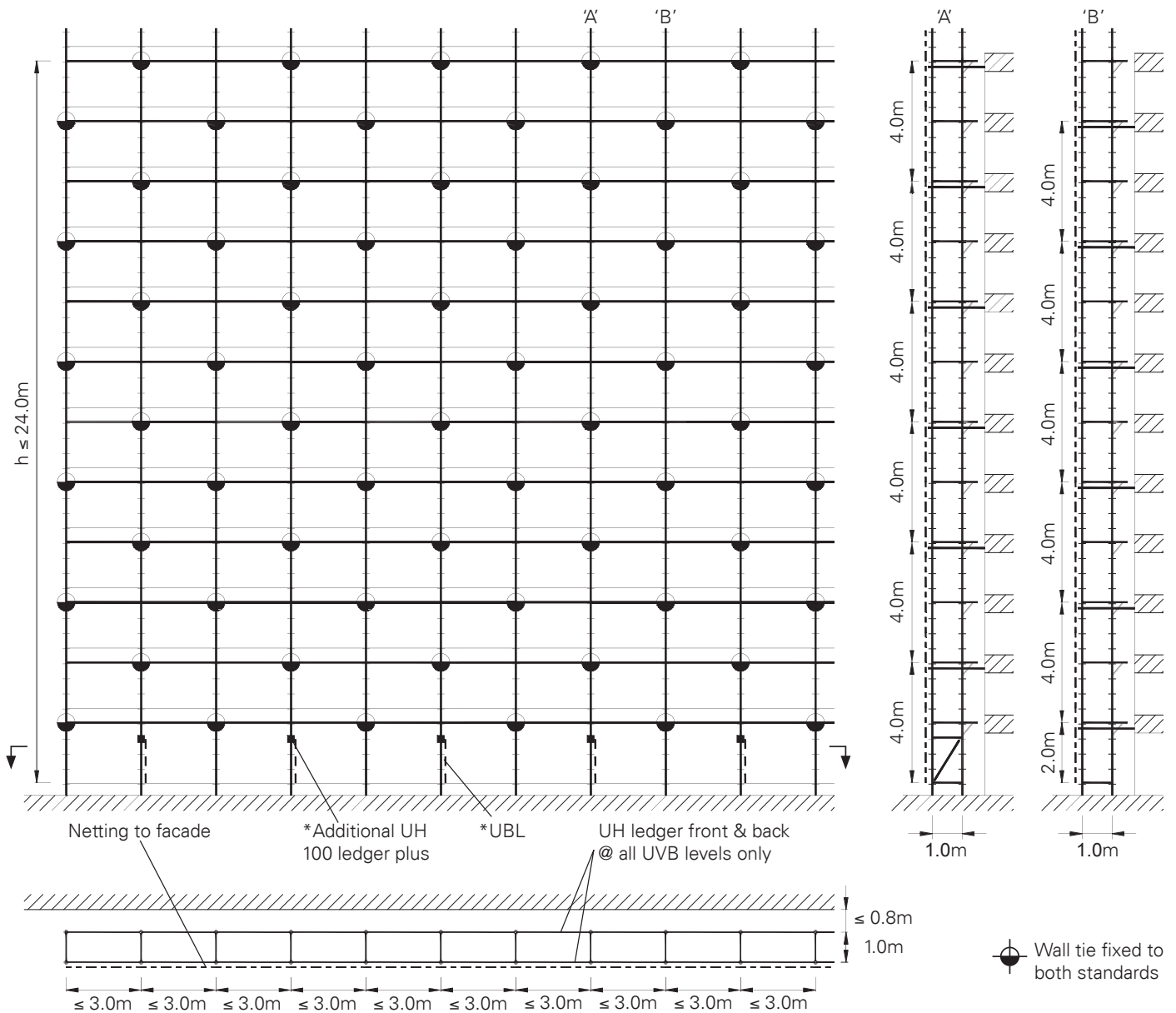

Note: Only structural components are indicated. All other necessary guard rail ledgers / toe boards omitted for clarity. Façade bracing is not required.

PERI UP Rosett Flex Working Scaffold 100 with Deck UDI B2 Anchor Patterns



B2.6.3.1 Pattern B3.1 Variation 1 (Lowest anchor at 4m)

Standard Configuration for netted scaffold tied to partly open (60%) structure.

Load class to EN 12811-1:	3 (2.0kN/m ²)	Max. base open dimension:	0.595m
Max. bay length:	3.00m	Max. base support reaction:	21.70kN
Max. scaffold width:	1.00m	Max. anchor force A :	1.61kN
Inside console brackets:	0.50m	Max. anchor force A _⊥ :	4.06kN
UDI decks:	All levels (except base)		
Scaffold façade:	Netting		

* Components not required for scaffolds with bay length ≤ 2.5m or height h ≤ 20m

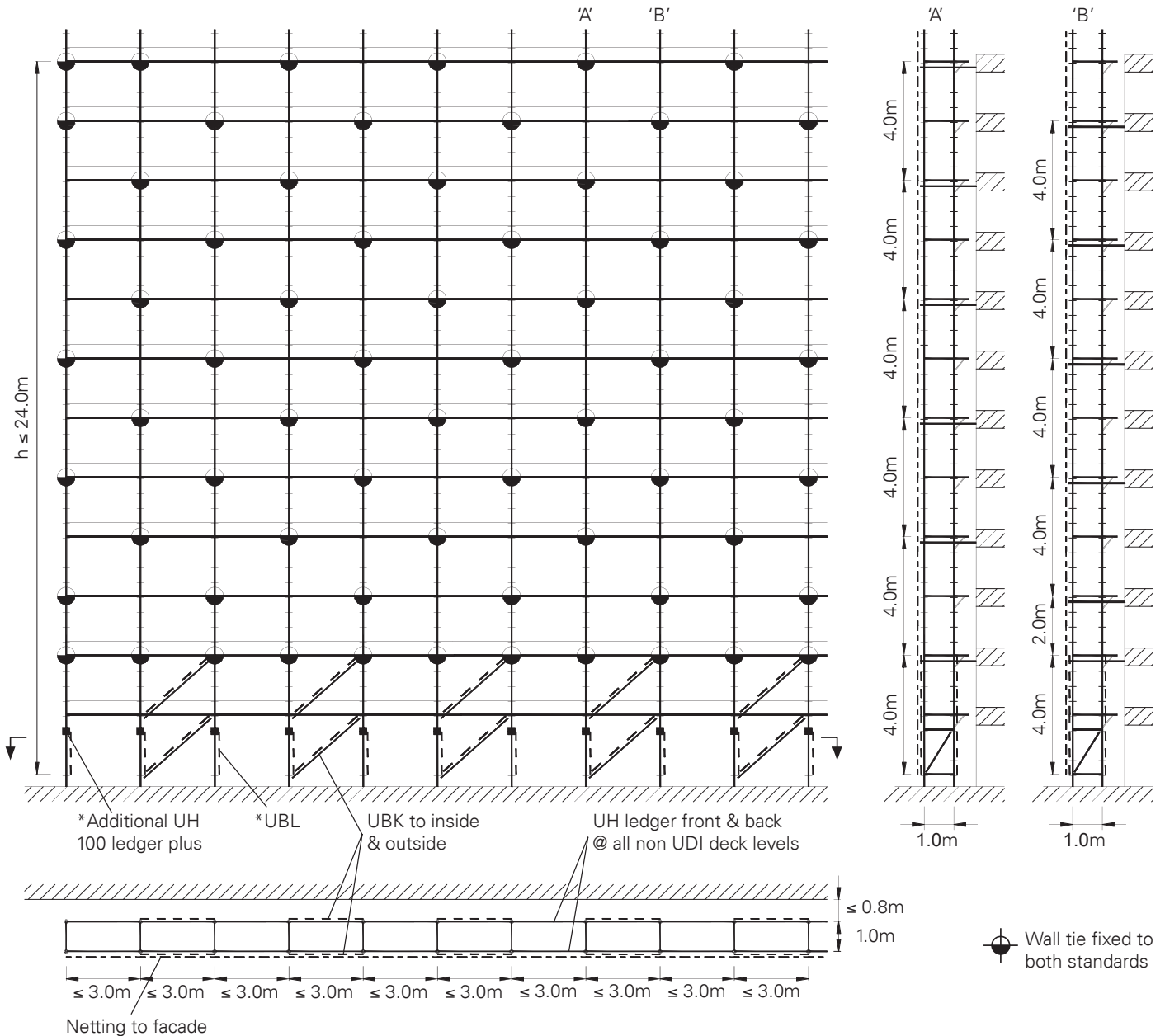

Note: Only structural components are indicated. All other necessary guard rail ledgers / toe boards omitted for clarity.
Façade bracing is not required above bottom wall ties.

PERI UP Rosett Flex Working Scaffold 100 with Deck UDI B2 Anchor Patterns



B2.6.5 Pattern B5

Standard Configuration for sheeted scaffold tied to partly open (60%) structure.

Load class to EN 12811-1:	3 (2.0kN/m ²)	Max. base open dimension:	0.595m
Max. bay length:	3.00m	Max. base support reaction:	21.70kN
Max. scaffold width:	1.00m	Max. anchor force A _{II} :	1.80kN
Inside console brackets:	0.50m	Max. anchor force A _I :	5.87kN
UDI decks:	All levels (except base)		
Scaffold façade:	Closed sheeting		

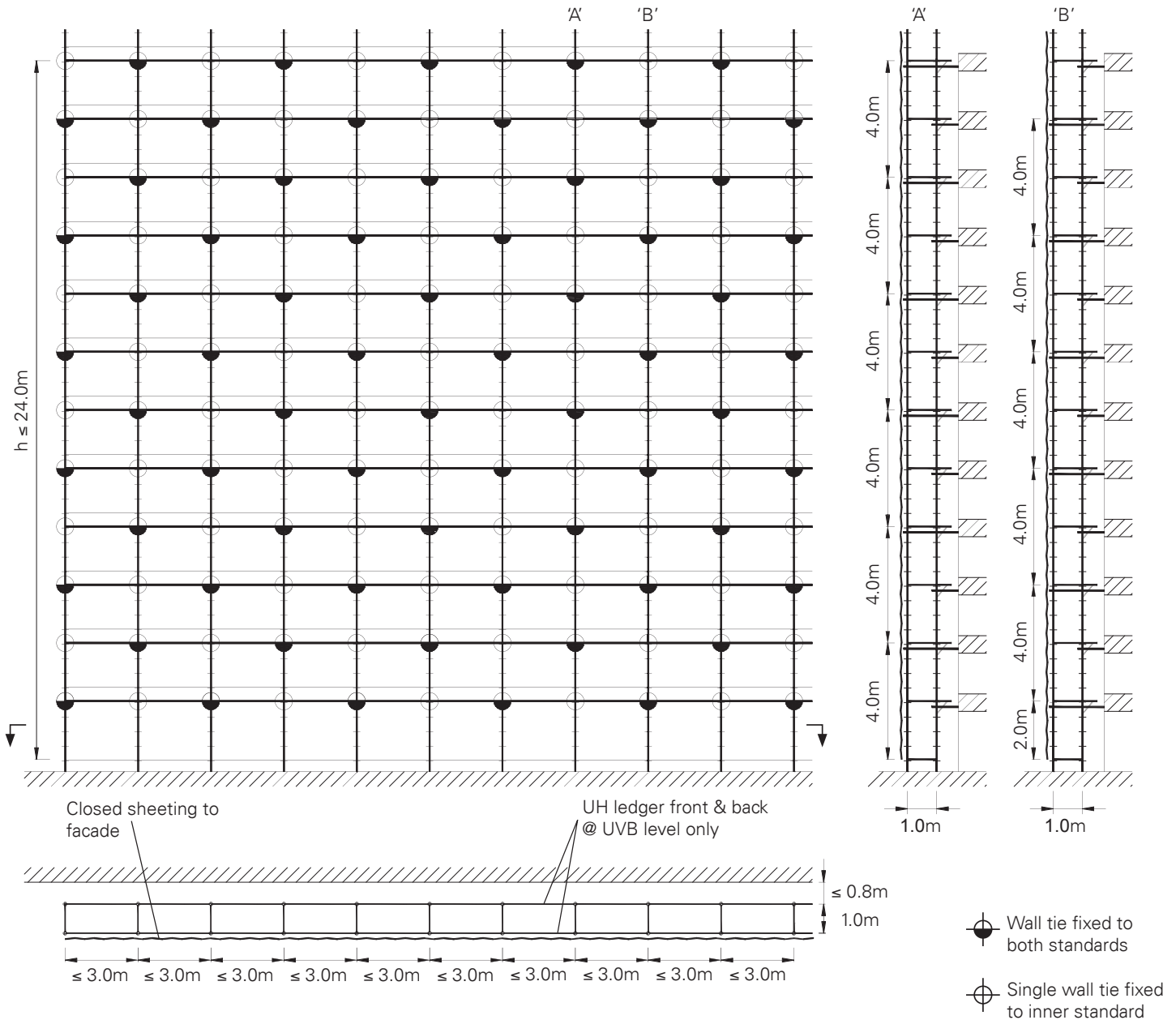

Note: Only structural components are indicated. All other necessary guard rail ledgers / toe boards omitted for clarity.
Façade bracing is not required.

PERI UP Rosett Flex Working Scaffold 100 with Deck UDI B2 Anchor Patterns



B2.6.6 Pattern B6

Standard Configuration for sheeted scaffold tied to partly open (60%) structure.

Load class to EN 12811-1:	3 (2.0kN/m ²)	Max. base open dimension:	0.595m
Max. bay length:	3.00m	Max. base support reaction:	11.70kN
Max. scaffold width:	1.00m	Max. anchor force A _{II} :	1.64kN
Inside console brackets:	0.50m	Max. anchor force A _I :	1.81kN
UDI decks:	Top 2 levels	* Components not required for scaffolds with bay length ≤ 2.5m or height h ≤ 20m	
Scaffold façade:	No sheeting or netting		

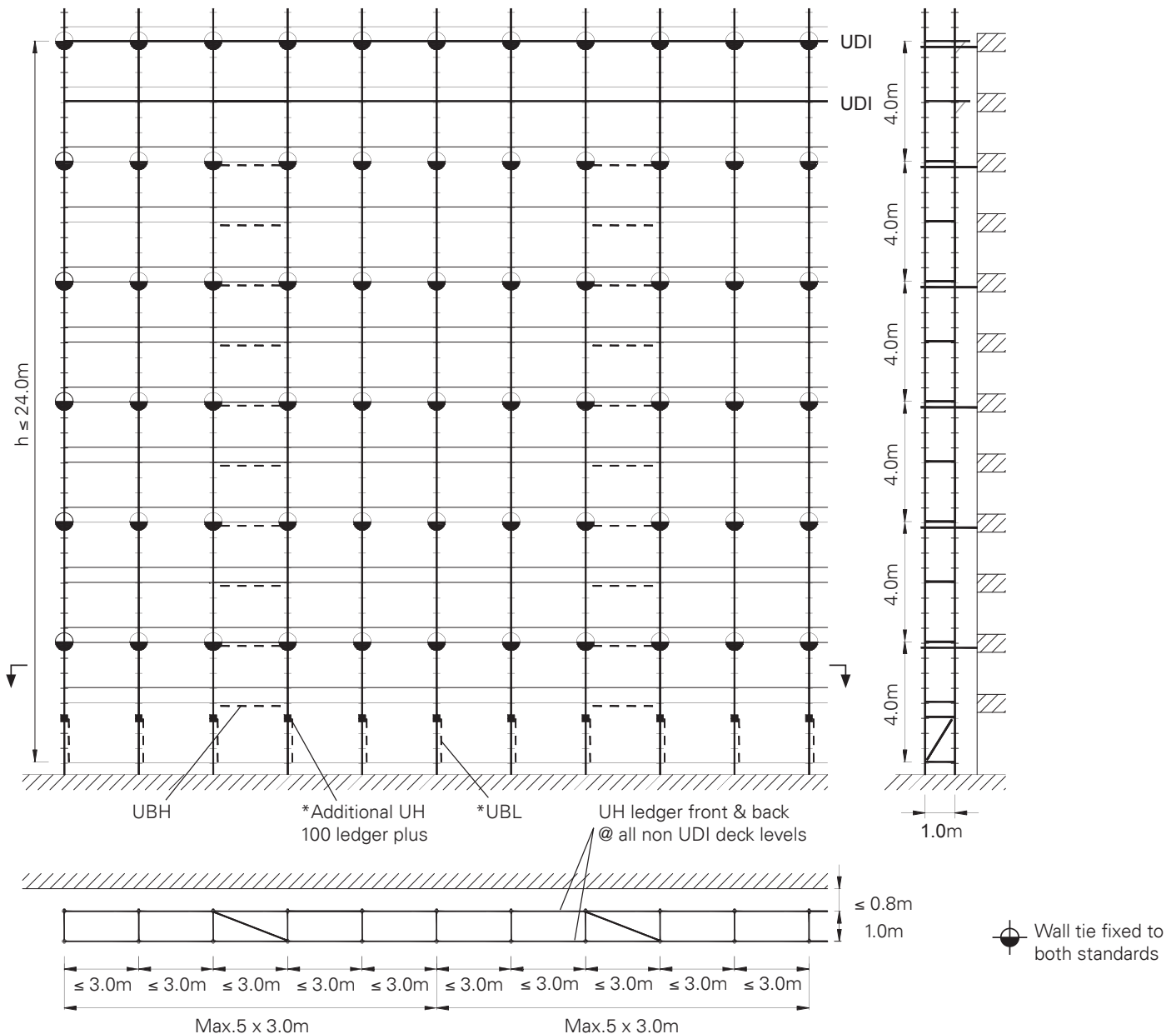

Note: Only structural components are indicated. All other necessary guard rail ledgers / toe boards omitted for clarity. Façade bracing is not required.

PERI UP Rosett Flex Working Scaffold 100 with Deck UDI

B2 Anchor Patterns

B2.6.6.1 Pattern B6.1 Variation 1 (Façade bracing)

Standard Configuration for scaffold tied to partly open (60%) structure.

Load class to EN 12811-1:	3 (2.0kN/m ²)	Max. base open dimension:	0.595m
Max. bay length:	3.00m	Max. base support reaction:	11.70kN
Max. scaffold width:	1.00m	Max. anchor force A _{II} :	1.64kN
Inside console brackets:	0.50m	Max. anchor force A _I :	1.81kN
UDI decks:	Top 2 levels	* Components not required for scaffolds with bay length ≤ 2.5m or height h ≤ 20m	
Scaffold façade:	No sheeting or netting		

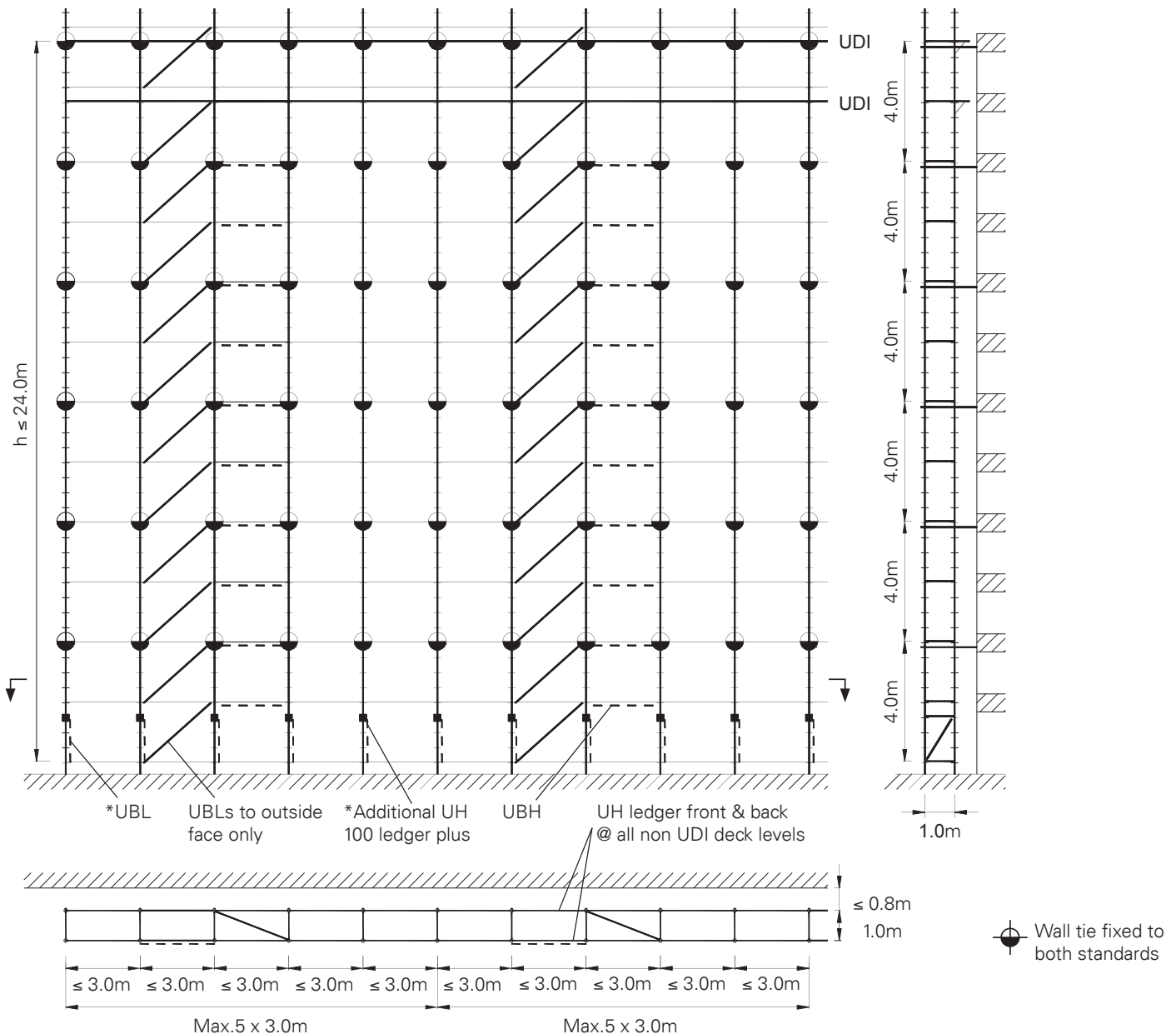

Note: Only structural components are indicated. All other necessary guard rail ledgers / toe boards omitted for clarity.
Façade bracing replaces intermediate Ledgers UH.

PERI UP Rosett Flex Working Scaffold 100 with Deck UDI B2 Anchor Patterns



B2.6.7 Pattern B7

Standard Configuration for scaffold tied to partly open (60%) structure.

Load class to EN 12811-1:	3 (2.0kN/m ²)	Max. base open dimension:	0.595m
Max. bay length:	3.00m	Max. base support reaction:	11.70kN
Max. scaffold width:	1.00m	Max. anchor force A _{II} :	1.61kN
Inside console brackets:	0.50m	Max. anchor force A _I :	4.06kN
UDI decks:	Top 2 levels		
Scaffold façade:	Netting		

* Components not required for scaffolds with bay length ≤ 2.5m or height h ≤ 20m

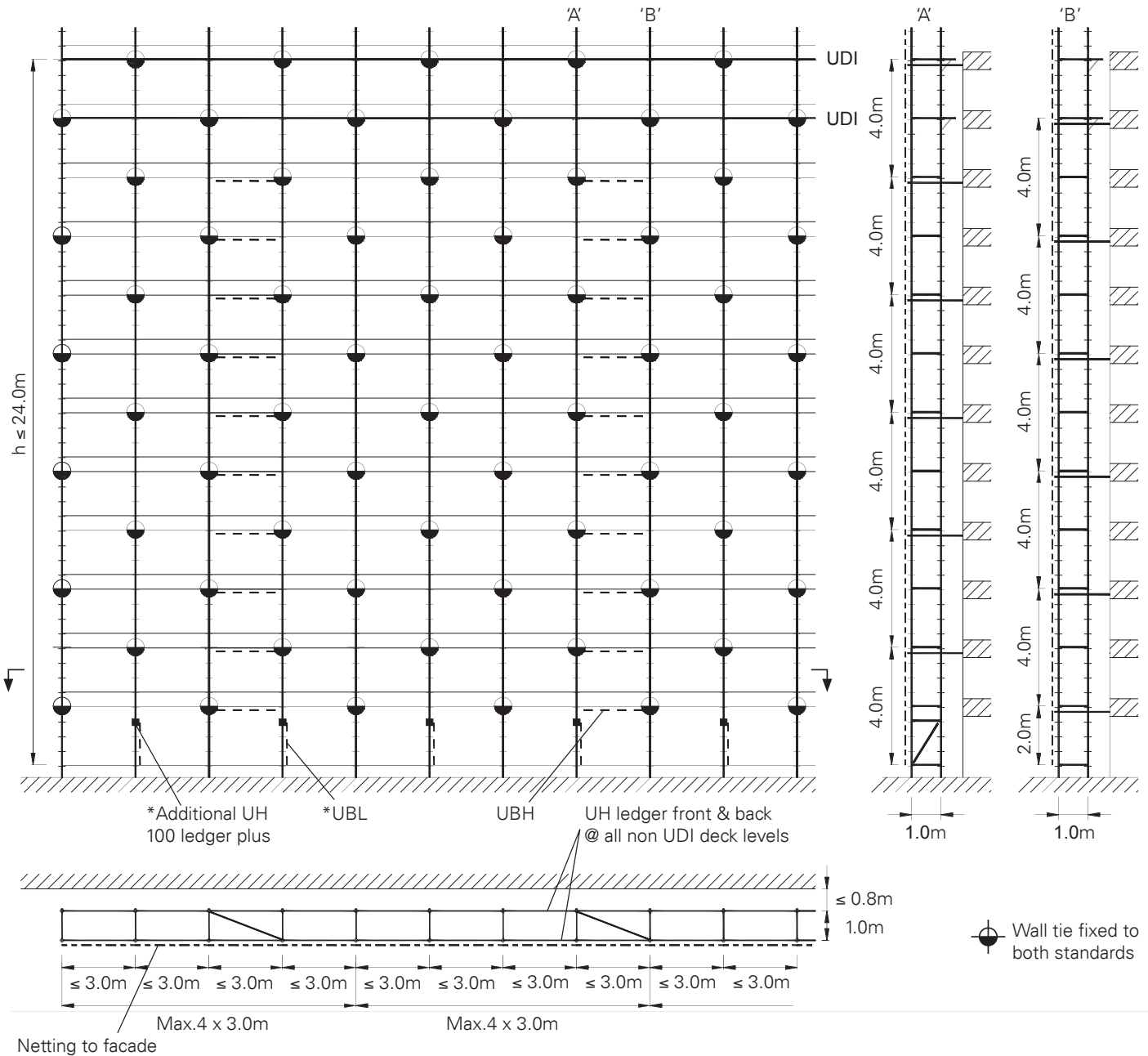

Note: Only structural components are indicated. All other necessary guard rail ledgers / toe boards omitted for clarity. Façade bracing is not required.

PERI UP Rosett Flex Working Scaffold 100 with Deck UDI B2 Anchor Patterns



B2.6.7.1 Pattern B7.1 Variation 1 (Lowest anchor at 4m)

Standard Configuration for netted scaffold tied to partly open (60%) structure.

Load class to EN 12811-1:	3 (2.0kN/m ²)	Max. base open dimension:	0.595m
Max. bay length:	3.00m	Max. base support reaction:	11.70kN
Max. scaffold width:	1.00m	Max. anchor force A _{II} :	1.61kN
Inside console brackets:	0.50m	Max. anchor force A _I :	4.06kN
UDI decks:	Top 2 levels		
Scaffold façade:	Netting		

* Components not required for scaffolds with bay length ≤ 2.5m or height h ≤ 20m

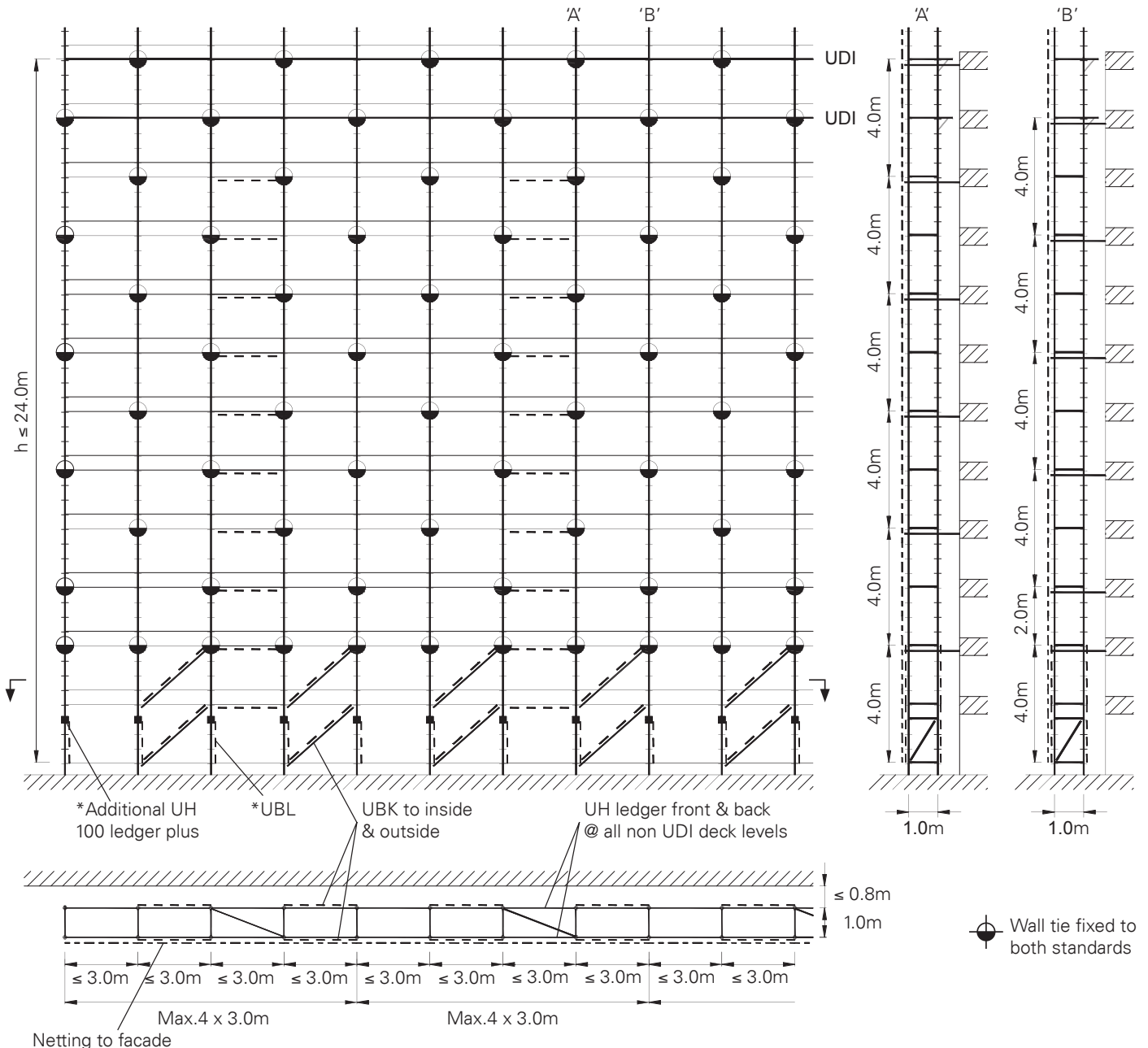

Note: Only structural components are indicated. All other necessary guard rail ledgers / toe boards omitted for clarity. Façade bracing is not required above bottom wall ties.

PERI UP Rosett Flex Working Scaffold 100 with Deck UDI B2 Anchor Patterns



B2.7.1 Pattern C1

Standard Configuration for scaffold tied to permeable open (85%) structure.

Load class to EN 12811-1:	3 (2.0kN/m ²)	Max. base open dimension:	0.595m
Max. bay length:	2.50m	Max. base support reaction:	18.80kN
Max. scaffold width:	1.00m	Max. anchor force A _{II} :	2.46kN
Inside console brackets:	0.50m	Max. anchor force A _I :	3.10kN
UDI decks:	All levels (except base)		
Scaffold façade:	No sheeting or netting		

* Components not required for scaffolds with bay length ≤ 2.0m or height h ≤ 16m

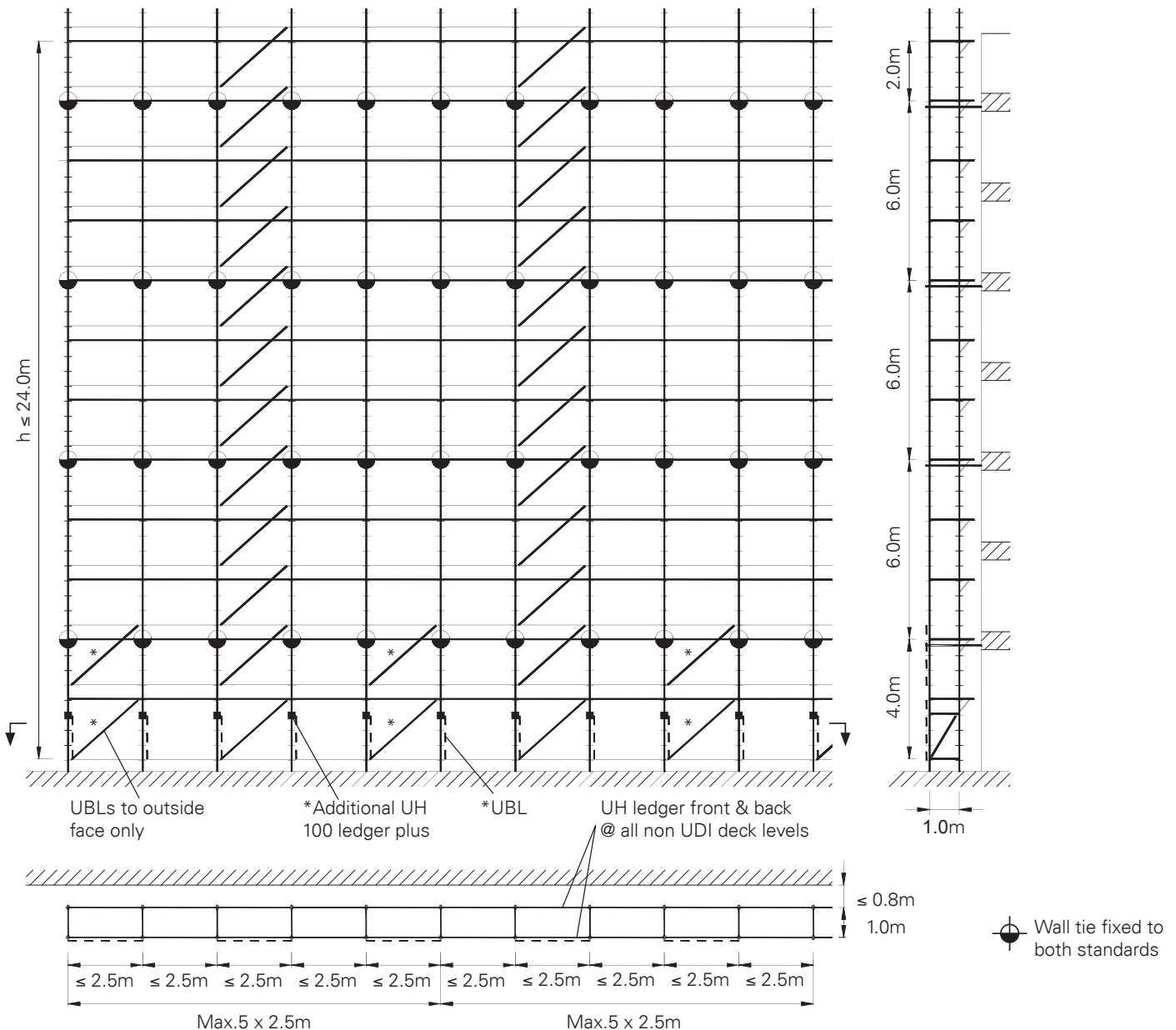

Note: Only structural components are indicated. All other necessary guard rail ledgers / toe boards omitted for clarity. Additional façade bracing is not required above bottom wall ties.

PERI UP Rosett Flex Working Scaffold 100 with Deck UDI B2 Anchor Patterns

B2.7.2 Pattern C2

Standard Configuration for netted scaffold tied to closed structure.

Load class to EN 12811-1:	3 (2.0kN/m ²)	Max. base open dimension:	0.595m
Max. bay length:	2.50m	Max. base support reaction:	18.80kN
Max. scaffold width:	1.00m	Max. anchor force A _{II} :	2.33kN
Inside console brackets:	0.50m	Max. anchor force A _I :	1.65kN
UDI decks:	All levels (except base)		
Scaffold façade:	Netting		

* Components not required for scaffolds with bay length ≤ 2.0m or height h ≤ 16m

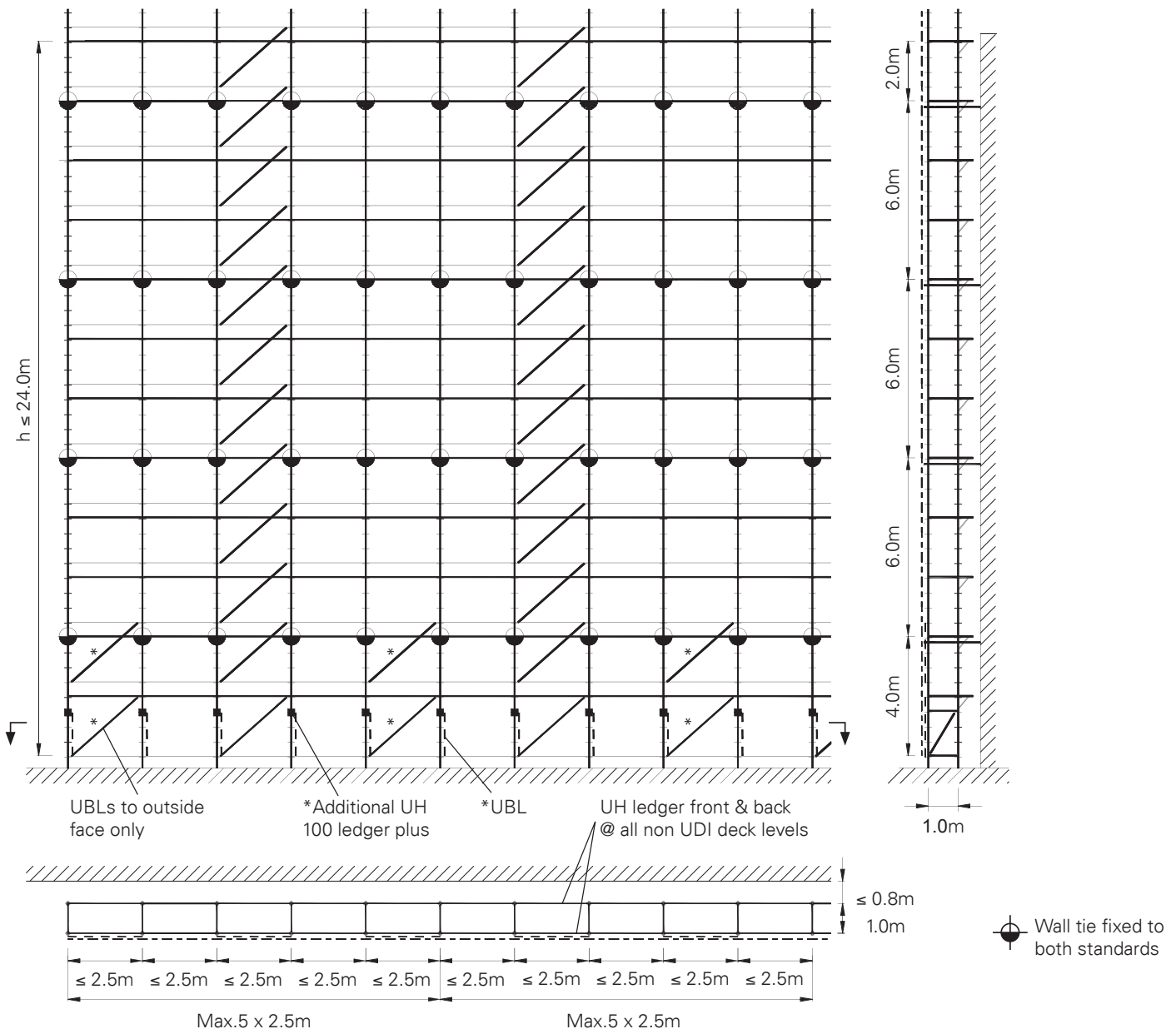

Note: Only structural components are indicated. All other necessary guard rail ledgers / toe boards omitted for clarity. Additional facade bracing is not required above bottom wall ties.

PERI UP Rosett Flex Working Scaffold 100 with Deck UDI

B3 Anchor and Base Forces

B3.1 Wall tie anchor forces

PERI UP Rosett Flex												
Anchor pattern	Cladding	Bay (m)	Anchor load for									
			Standard configuration with closed façade		Standard configuration with part open façade*		Standard configuration with open façade**					
			Wall tie									
			A_{\perp} (kN)	A_{\parallel} (kN)	A_{\perp} (kN)	A_{\parallel} (kN)	A_{\perp} (kN)	A_{\parallel} (kN)				
4m regular	None	2.50	0.52	1.64	1.55	1.64						
		3.00	0.60	1.64	1.81	1.64						
	Netting	2.50	1.10	1.55								
		3.00	1.32	1.68								
4m offset	Netting	2.50	1.13	0.80			3.39	1.42				
		3.00	1.35	0.86			4.06	1.61				
4m offset +	Netting	2.50	4.89	1.67								
		3.00	5.87	1.80								
4m offset +	Closed sheeting	2.50	4.89	1.67					4.89	1.67		
		3.00	5.87	1.80					5.87	1.80		
6m regular	None	2.50	0.78	2.46	2.33	2.46	3.10	2.46				
	Netting	2.50	1.65	2.33								

Table B3-1

Key: Wall tie fixed to both standards

* Part open façade = 40% solid / 60% open

Compression wall tie fixed to inner standard

** Open façade = 85% open

Single wall tie fixed to inner standard

A_{\perp} = perpendicular loads, A_{\parallel} = parallel loads

Anchor Patterns:

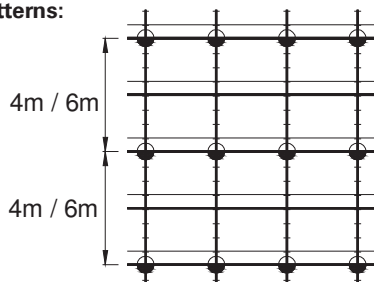

Fig. B3-1

4m / 6m regular

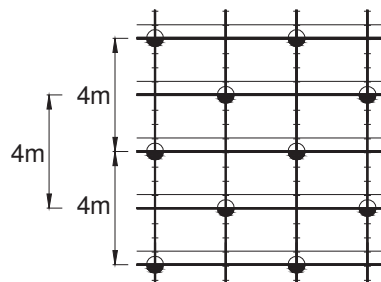

Fig. B3-2

4m offset

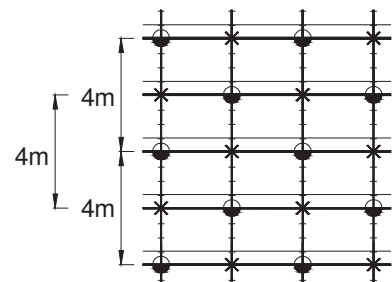

Fig. B3-3

4m offset + (or)

PERI UP Rosett Flex Working Scaffold 100 with Deck UDI

B3 Anchor and Base Forces

B3.2 Triangulated anchor and single wall tie anchor forces

PERI UP Rosett Flex														
Anchor pattern	Cladding	Bay (m)	Anchor load for											
			Standard configuration with closed façade			Standard configuration with part open façade*			Standard configuration with open façade**					
			Single wall ties	Triangulated anchors		Single wall ties	Triangulated anchors		Single wall ties	Triangulated anchors				
			A_{\perp} (kN)	A'_{\perp} (kN)	A'_{\parallel} (kN)	A_{\perp} (kN)	A'_{\perp} (kN)	A'_{\parallel} (kN)	A_{\perp} (kN)	A'_{\perp} (kN)	A'_{\parallel} (kN)			
4m regular	None	2.50	0.52	2.47	2.47	1.55	2.47	2.47						
		3.00	0.60	2.47	2.47	1.81	2.47	2.47						
	Netting	2.50	1.10	2.33	2.33									
		3.00	1.32	2.51	2.51									
4m offset	Netting	2.50	1.13	1.19	1.19							3.39	2.13	2.13
		3.00	1.35	1.29	1.29							4.06	2.42	2.42
4m offset +	Netting	2.50	4.89	2.51	2.51									
		3.00	5.87	2.93	2.93									
4m offset +	Closed sheeting	2.50	4.89	2.51	2.51	4.89	2.51	2.51						
		3.00	5.87	2.93	2.93	5.87	2.93	2.93						
6m regular	None	2.50	0.78	3.69	3.69	2.33	3.69	3.69				3.10	3.69	3.69
	Netting	2.50	1.65	3.50	3.50									

Table B3-2

Key: Triangulated anchors

Compression wall tie fixed to inner standard

Single wall tie fixed to inner standard

Values for anchors are per single Wall Tie UWT (13), based on one triangulated anchor and two single ties replacing three wall ties:

* Part open façade = 40% solid / 60% open

** Open façade = 85% open

A_{\perp} = perpendicular loads, A_{\parallel} = parallel loads

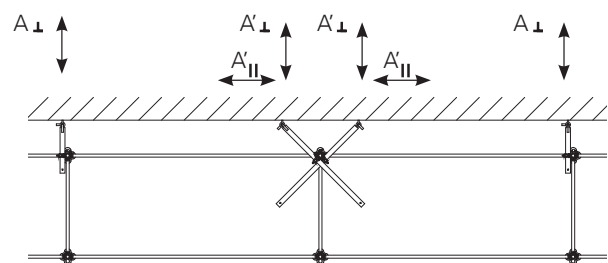

Fig. B3-4

PERI UP Rosett Flex Working Scaffold 100 with Deck UDI

B3 Anchor and Base Forces

B3.3 Base forces load class 4

PERI UP Rosett Flex - For use up to load class 4 (3.00 kN/m ²) (One working platform)					
	Consoles	Bay length	Height of scaffold		
			24m	16m	8m
	Internal leg load				
			F_i (kN)	F_i (kN)	F_i (kN)
	Without internal console brackets	2.00m	10.00	8.20	6.40
		2.50m	12.00	9.90	7.80
	With internal console brackets UCM 50	2.00m	18.60	15.50	12.50
		2.50m	22.00	18.40	14.90
	External leg load				
			F_e (kN)	F_e (kN)	F_e (kN)
	N/A	2.00m	11.20	9.10	7.00
		2.50m	13.40	10.90	8.40

Table B3-3

B3.4 Base forces load class 3

PERI UP Rosett Flex - For use up to load class 3 (2.00 kN/m ²) (One working platform)					
	Consoles	Bay length	Height of scaffold		
			24m	16m	8m
	Internal leg load				
			F_i (kN)	F_i (kN)	F_i (kN)
	Without internal console brackets	2.50m	10.10	8.00	5.90
		3.00m	11.70	9.40	7.00
	With internal console brackets UCM 50	2.50m	18.80	15.30	11.80
		3.00m	21.70	17.60	13.60
	External leg load				
			F_e (kN)	F_e (kN)	F_e (kN)
	N/A	2.50m	11.70	9.10	6.60
		3.00m	13.60	10.70	7.80

Table B3-4

C – Ancillary Applications

C1 Scaffold Access

C1.1 External access tower 75 with Staircase UAS (In line stairs)

Access can be achieved on the outside of the scaffold by use of the Staircase UAS (20).

The Staircase UAS (20) is positioned on the Ledger UH 75 (4) in the same way as the Industrial Deck UDI. The Stair Guardrail UAG (21) is fixed on the staircase stringer and pushed downwards to lock behind a tread. At the top deck level, Guard rail Ledgers UH (4) & toe boards UPY (10) are fitted to the scaffold via the top Standard UVH 100 (5) and Spigot UH (22).

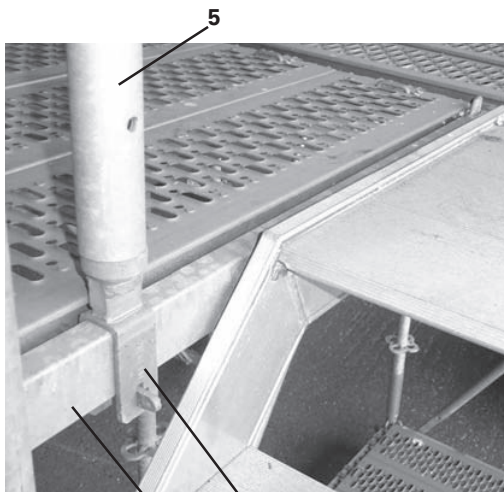

Fig.C1-1a 4 22

The staircase area is fully guarded by use of the Stair Guardrail UAH (31).



Fig.C1-1b 20 21 31

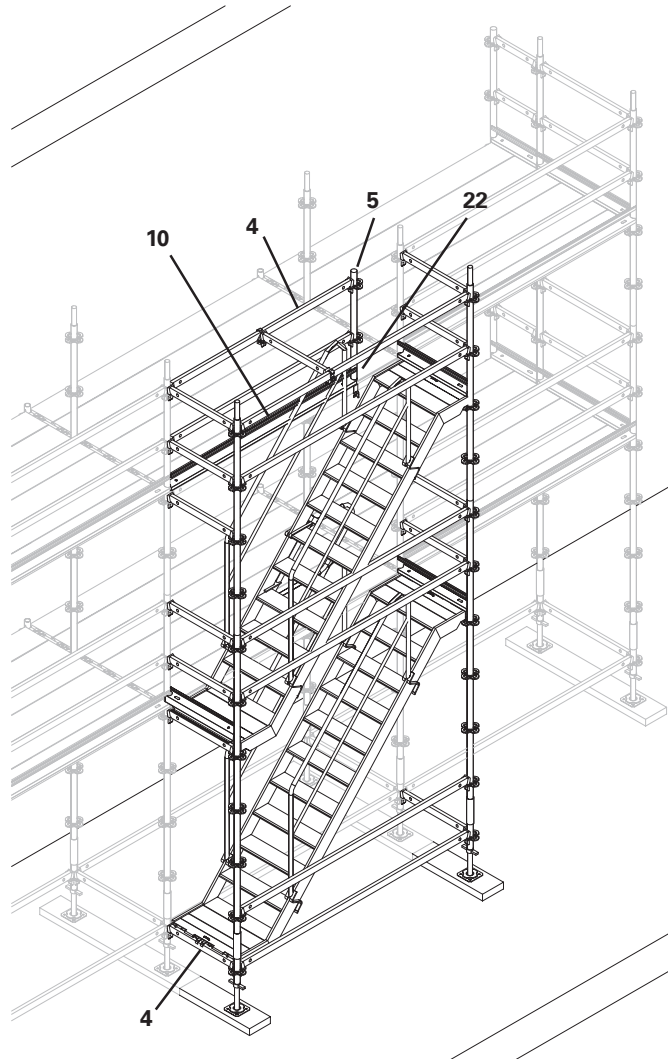

Fig.C1-1



For full details refer to Stair Tower 75 with Deck UDI Assembly Instructions.

Example subject to design, considering all possible loading combinations.

PERI UP Rosett Flex Working Scaffold 100 with Deck UDI

C1 Scaffold Access



C1.2 External access tower 150 with Staircase UAS (alternating stairs)

Access can be achieved on the outside of the scaffold by use of the Staircase UAS (20).

The Staircase UAS (20) is positioned on the Ledger UH 150 (4) in the same way as the Industrial Deck UDI. The Stair Guardrail UAG (21) is fixed on the staircase stringer and pushed downwards to lock behind a tread. Guard rail Ledgers UH (4) & toe boards UPY (10) are fitted to the scaffold via the top Standard UVH 100 (5) and Spigot UH (22).

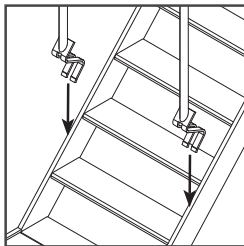

Fig.C1-2

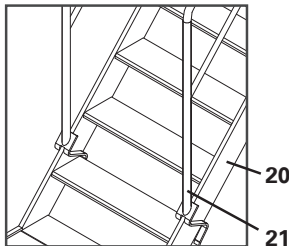

Fig.C1-3

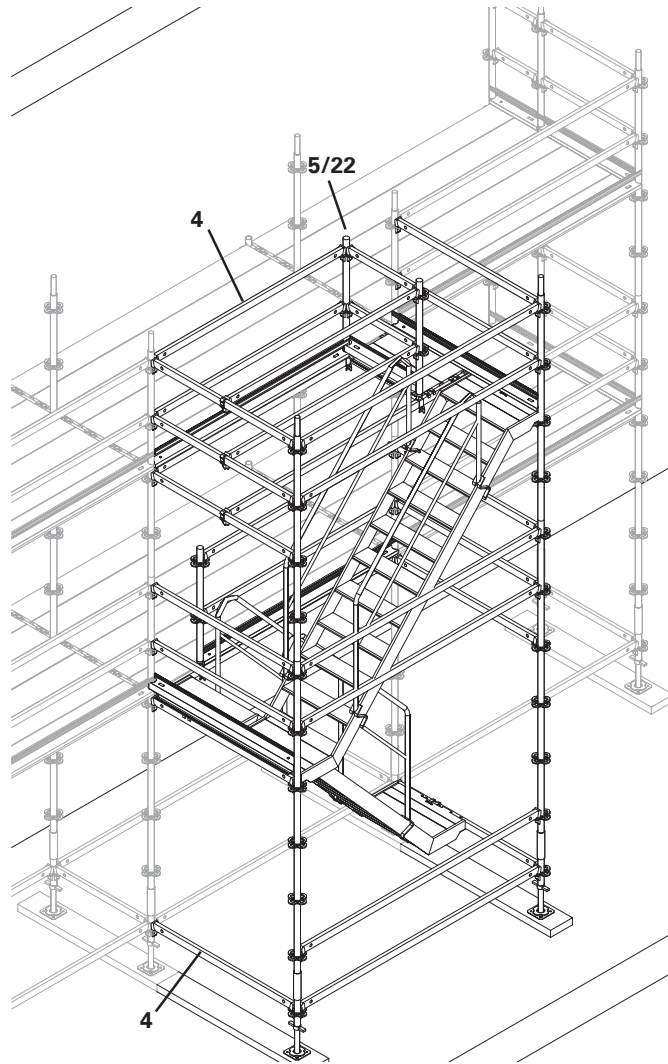
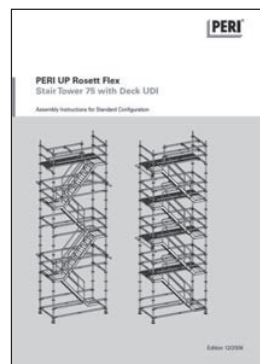

Fig.C1-4



For full details refer to Stair Tower 75 with Deck UDI Assembly Instructions.

Example subject to design, considering all possible loading combinations.

PERI UP Rosett Flex Working Scaffold 100 with Deck UDI C1 Scaffold Access



C1.3 External Stair Tower 100

Access can be achieved on the outside of the scaffold by use of the Staircase Tower 100.

The stair tower 100 is positioned outside the façade scaffold. Connection to the scaffold is by Ledgers UH 50 (4) and, where required, by the H-Brace UBH Flex (8).

Landings of Industrial Decks UDI (7) are connected by Stair Steps UAR (28) seated on Stair Stringers UA 250/200 (29). The guard rails are provided by Node Brace UBK 250/200 (30).

Clear, unobstructed stair access with Stair Tower 100:



Fig.C1-5a

Simple connection without the need for tools. Stair Steps UAR (28) are connected by interlocking with previous step and turning on to Stair Stringer UA 250/200 (29). Each step is locked by the upper step and finally locked to the landing by the End Step UAE.



Fig.C1-6

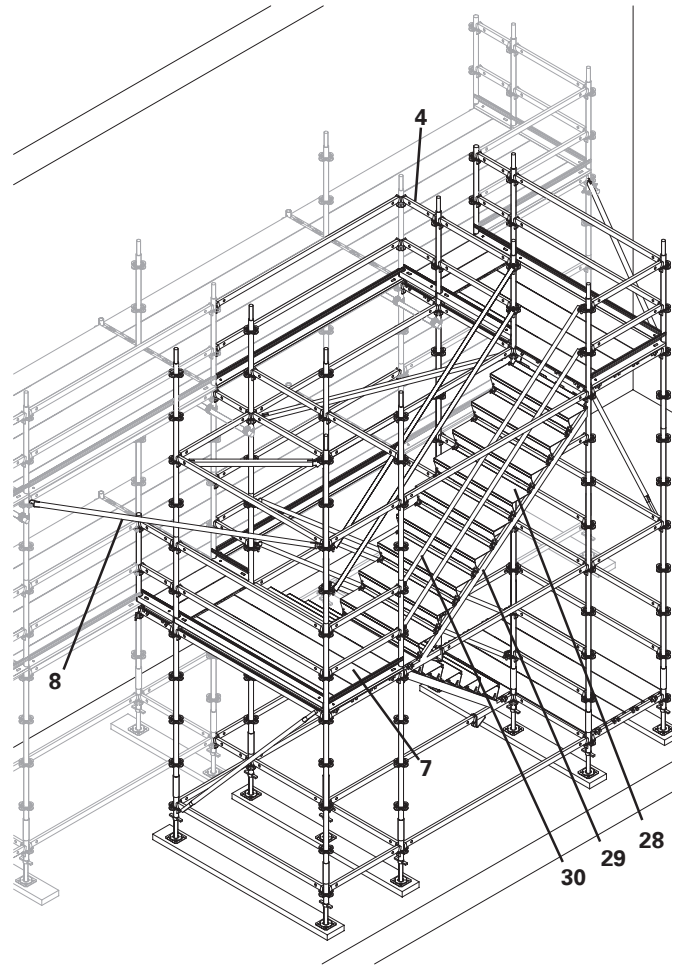

Fig.C1-5



For full details refer to Stair Tower 100 and 125 with Deck UDI Assembly Instructions.

Example subject to design, considering all possible loading combinations.

PERI UP Rosett Flex Working Scaffold 100 with Deck UDI C1 Scaffold Access

C1.4 External access tower with Hatch UAF

Access can be achieved on the outside of the scaffold by use of the Hatch UAF (11) and Ladder (12) in a connected bay using Ledger UH 75 (4).

At the base level, a Ledger UH (4) and Industrial Decks UDI (7) should be fitted in the outer bay.

Hatches UAF (11) are painted yellow for clear identification on the deck. They open sideways from the ladder and close automatically after use.



Fig.C1-7

Example subject to design, considering all possible loading combinations.

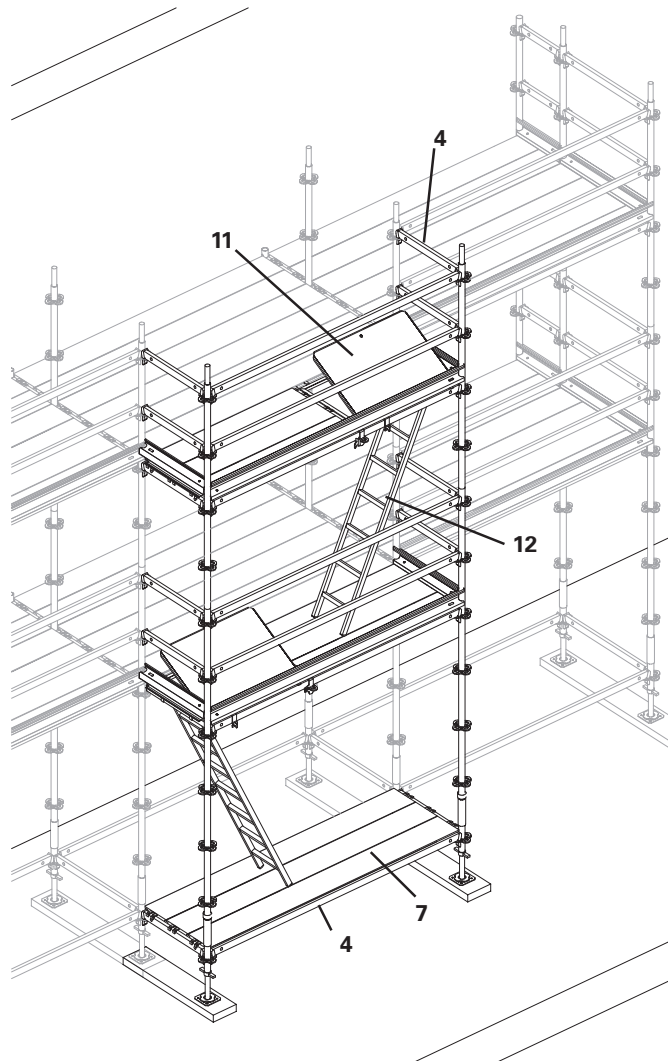

Fig.C1-8

PERI UP Rosett Flex Working Scaffold 100 with Deck UDI

C1 Scaffold Access

C1.5 Access towers to floor slabs

Scaffold access may be provided to floor slabs utilising the range of Staircase UAS components.

Access can be created to all floors in height increments of 25cm.

Typical 3m storey height construction may be accessed using the Staircase UAS 75 x 150/100 (20a).

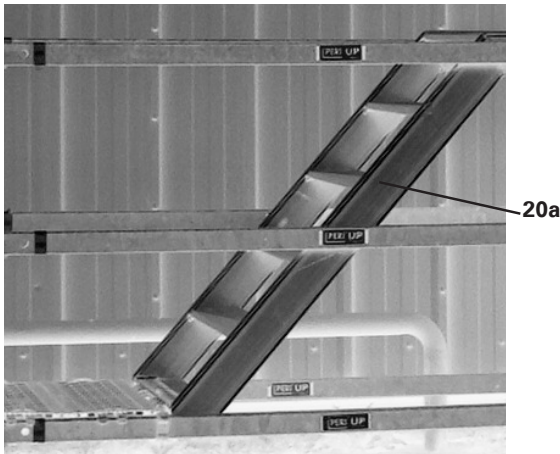

Fig.C1-9a

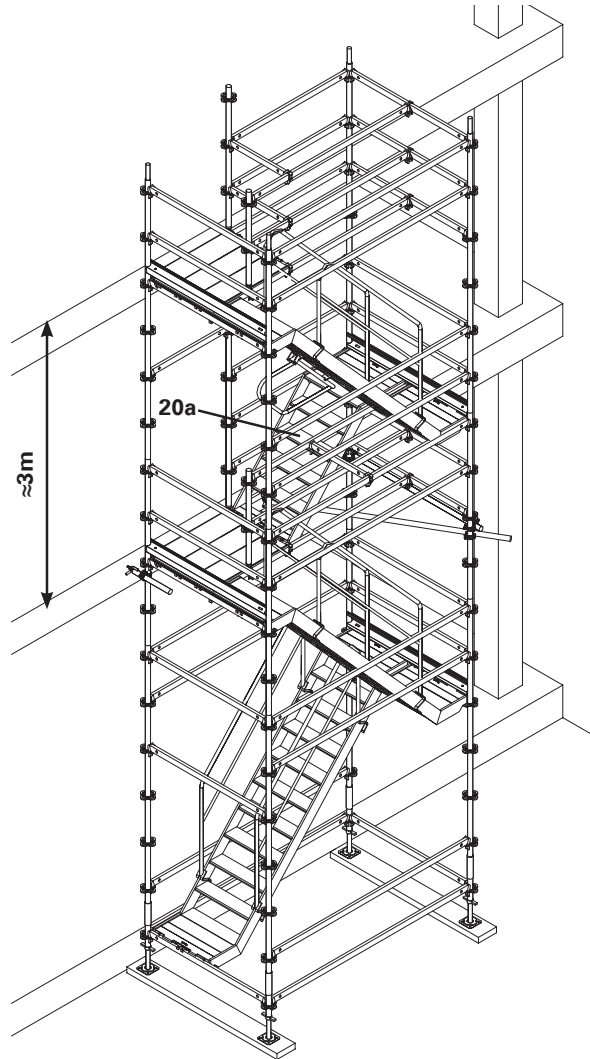
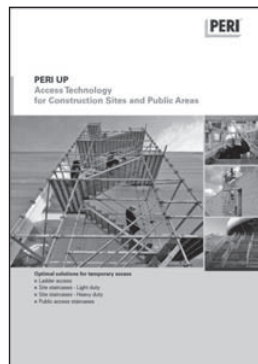

Fig.C1-9



For a wide range of stair options refer to Access Technology for Construction Sites and Public Areas.

Example subject to design, considering all possible loading combinations.

PERI UP Rosett Flex Working Scaffold 100 with Deck UDI

C2 Loading Towers

C2.1 Using Ledger UHV

Loading tower can be positioned on the outside of the scaffold with the Ledger UHV (23).

- Plan dimensions = 2.0m x 2.5m
- Max Permissible Top Platform Load = 40kN (Evenly distributed e.g. 4 x 1000kg brick pallets)
- Max 2 No Intermediate Platforms @ 1.5kN/m²

The Industrial Decks UDI (7) are supported on increased capacity Ledgers UHV 200 (23).

The Loading Tower Gate automatically guards off the façade scaffold when the platform is being loaded.

A side gantry platform on Console Brackets UCM (6) at the front and connected to the scaffold with Spigot UH (22) provides safe access area for gate operation / banksman.

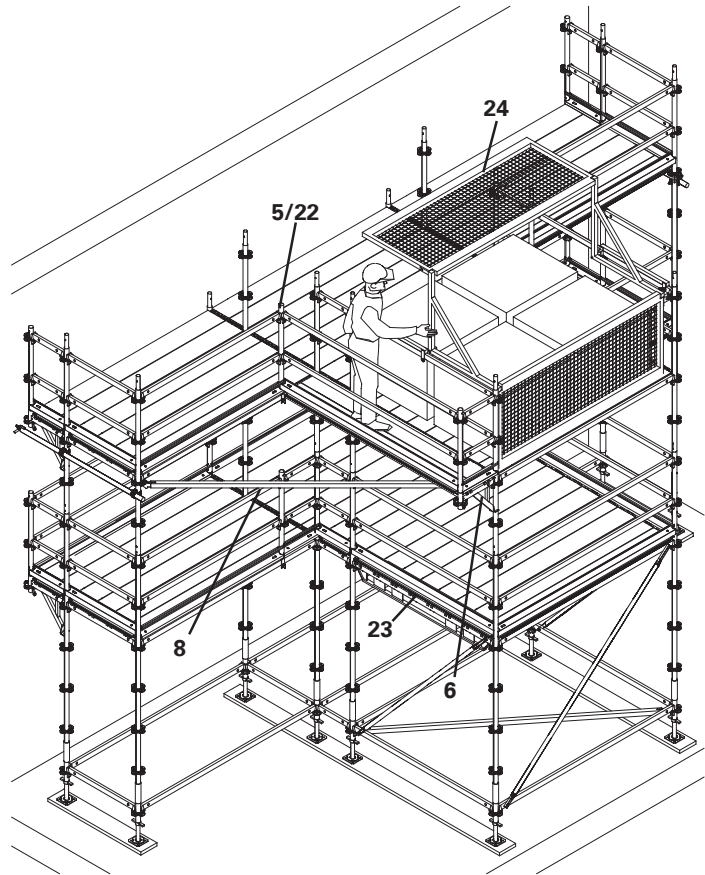

Fig.C2-1

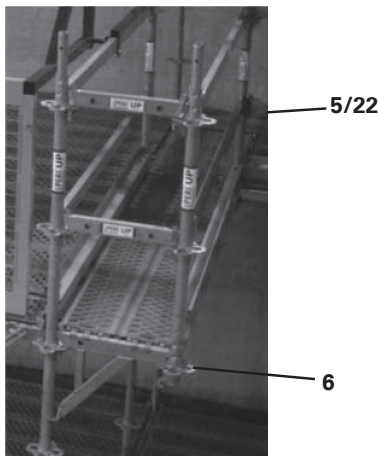

Fig.C2-1a

Plan bracing is provided by the H-Brace UBH Flex (8) which fits above or below the Rosett. Fitting below the Rosett enables unobstructed use of UDI decks on the UH Ledgers.

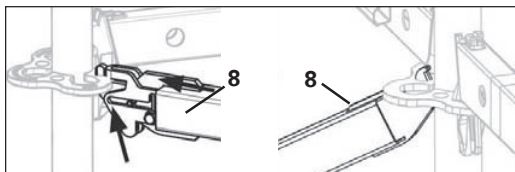

Fig.C2-2

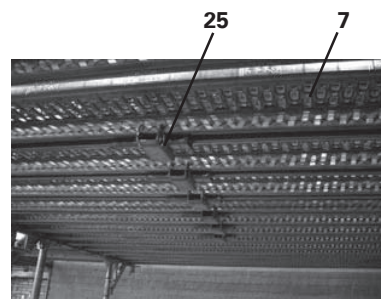

Fig.C2-1b

Industrial Decks UDI 250 (7) may be strengthened against deflection by use of Deck Link Plates UDC (25) fixed mid span.

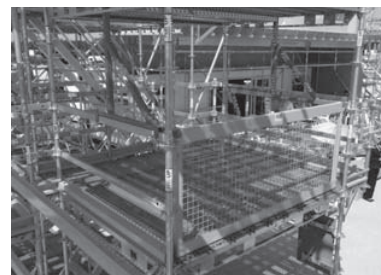

Fig.C2-3

The Loading Tower Gate (24) may be used at lower levels without clashing with platforms above.

Example subject to design, considering all possible loading combinations.

C3 Corners

C3.1 External corner fixed

The corner is formed by connecting external Ledgers UH (4) to the outside Standard UVR (5) of an end bay, with the inside Ledgers UH (4) connected direct to Ledgers UH (4) using Ledger to Ledger Couplers UHA (26). Industrial Decks UDI (7) span direct on to the inner Ledger UH (4).

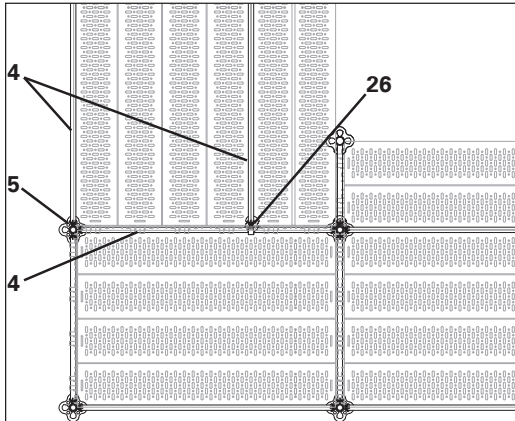

Fig.C3-1a

C3.2 External corner fly-past

The corner is formed by connecting the outside ledgers to a Standard UVR (5) seated on a Spigot UH (22) with the inside Ledgers UH (4) connected direct to Ledgers UH (4) using Ledger to Ledger Couplers UHA (26). Industrial Decks UDI (7) span direct on to the inner Ledger UH (4). External guard rail is maintained using lapped short length Ledgers UH (4). Internal Industrial Decks UDI (7) are supported on Ledgers UH (4) fitted in the Console Bracket UCM (6).

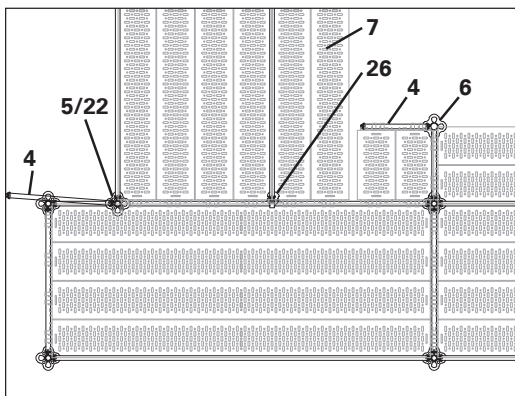

Fig.C3-2a

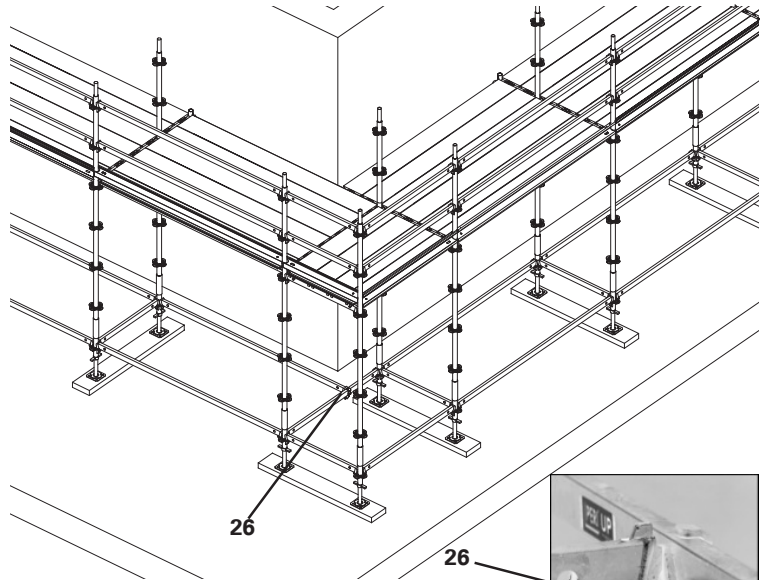

Fig.C3-1

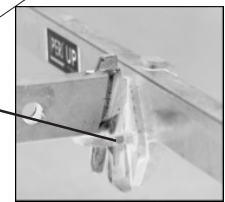

Fig.C3-1b

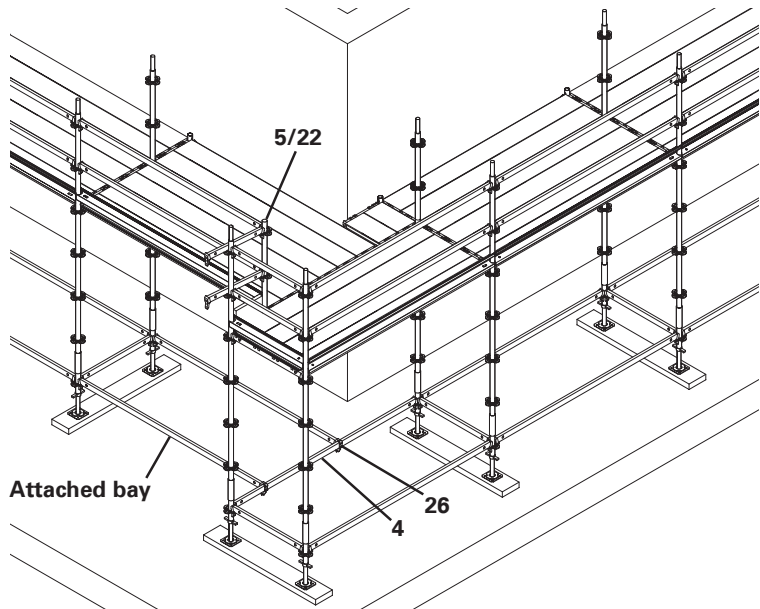

Fig.C3-2

PERI UP Rosett Flex – Permissible Corner Loads				
UH:	Attached bay length (m)			
	1.5	2.0	2.5	3.0
150	LC5	LC4	LC4	LC3
200	LC4	LC3	LC3	LC3
250	LC4	LC3	LC2	LC2
300	LC3	LC2	LC1	LC1

Table C3-1

C3 Corners

C3.3 Internal corner fixed

The corner is formed by connecting external Ledgers UH (4) to the outside Standard UVR (5) of an end bay, with the inside Ledgers UH (4) connected direct to Ledgers UH (4) using Ledger to Ledger Couplers UHA (26). Industrial Decks UDI (7) span direct on to the inner Ledger UH (4).

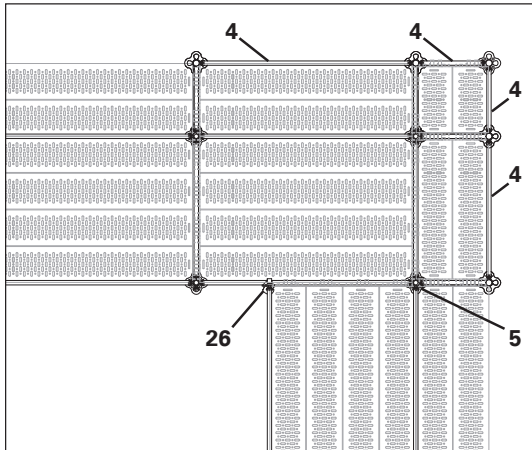

Fig.C3-3a

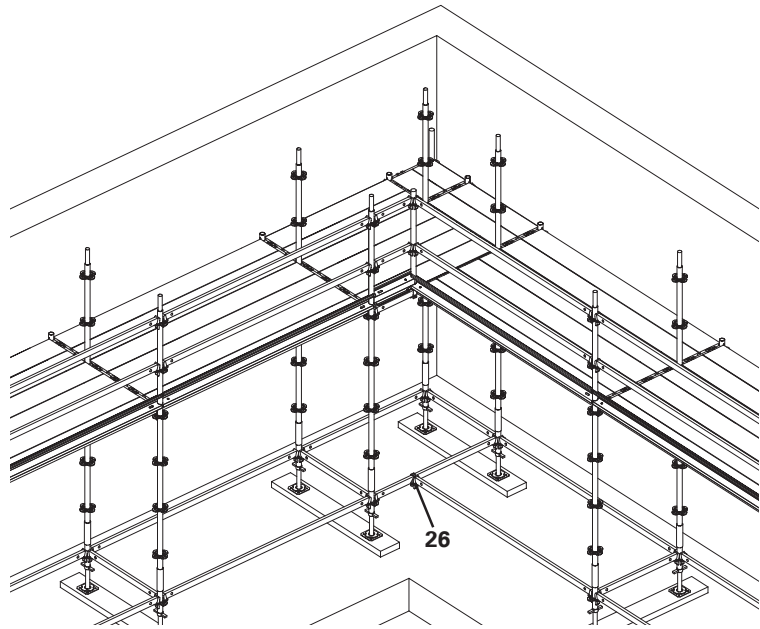

Fig.C3-3

C3.3.1 Internal corner detail Console UCM

The console corner is formed by connecting internal Ledgers UH (4) to the Console Brackets UCM (6). The corner internal Ledgers UH (4) are connected together with an inverted Top Standard UVH 50 (5) secured in position with a scaffold coupler. Console Brackets UCM (6) are connected together with Ledgers UH 50 (4) each side of the corner Brackets.

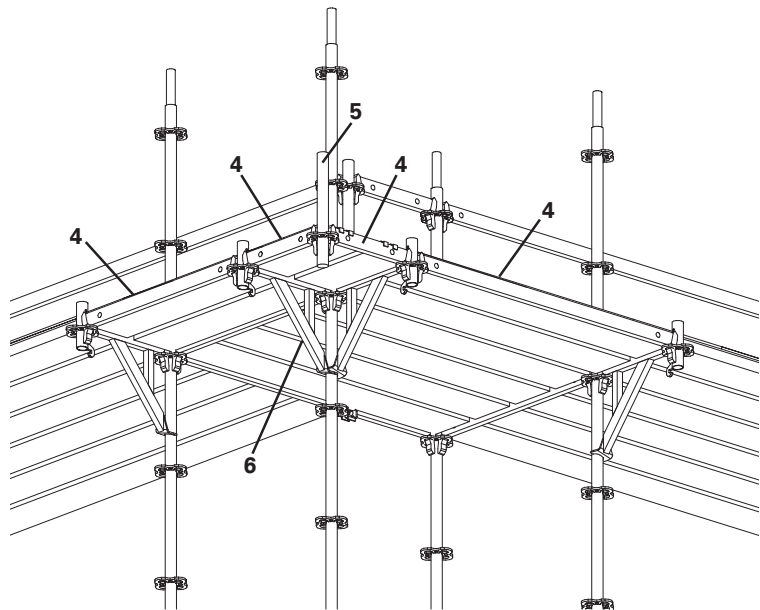

Fig.C3-3b
Corner view from below

PERI UP Rosett Flex Working Scaffold 100 with Deck UDI C4 Bridging Obstructions & Openings

C4.1 Bridging

To bridge openings or entrances to buildings, Industrial Decks UDI (7) and Ledgers UH (4) up to 4.0m may be used. For greater spans, scaffold bays can be supported using standard PERI-UP components.

C4.1.1 Using Console Brackets UCM

Bridge opening using Console Bracket UCM (6) and Console Bracket Brace UCM (17). All components can be fitted from the main scaffold behind Ledgers UH 100 Plus (3) used as guard rails.



Do not extend Vertical Standards UVR (5) seated in Console Brackets UCM (6). Console brackets UCM (6) to support one level only.

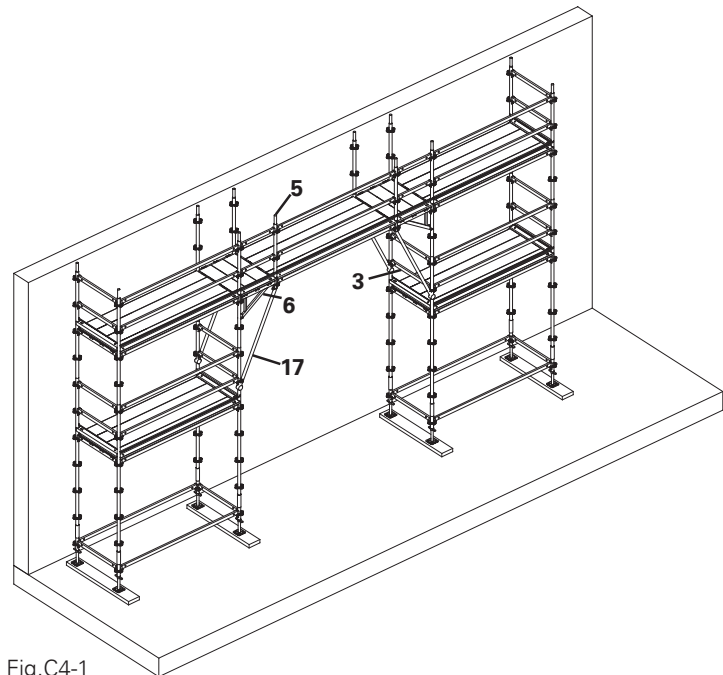

Fig.C4-1

C4.1.2 Using Node Braces UBK

Bridge opening using cantilevered Ledgers UH (4) connected to transverse Ledger 100 plus (3) by Base Standard UVB 24 (2) and secured with diagonal brace UBK (30).

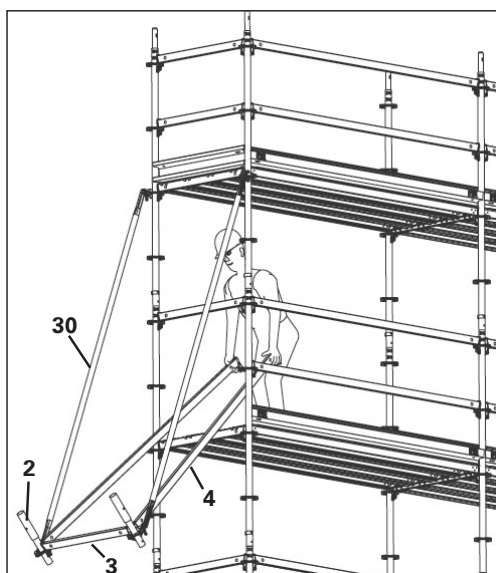

Fig.C4-2

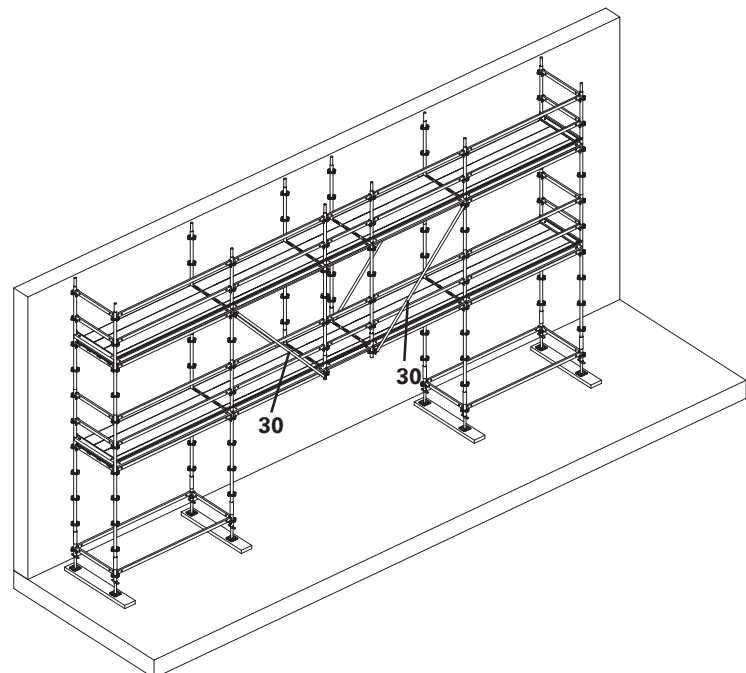

Fig.C4-3

PERI UP Rosett Flex Working Scaffold 100 with Deck UDI C5 Pedestrian Access

C5.1 Using Ledger UHV

Safe conditions for pedestrians may be created using the Ledger UHV.

Pairs of Standards UVR (5) connected with Ledgers UH 25 (4) are connected by Ledger UHV (23). A Ledger to Ledger Coupler UHA w. Spigot (27) is fixed to the Ledger UHV (23) to provide the support to the upper scaffold outer leg. Protection is provided to the passageway by fitting Industrial Decks UDI (7) at the Ledger UHV (23) level.

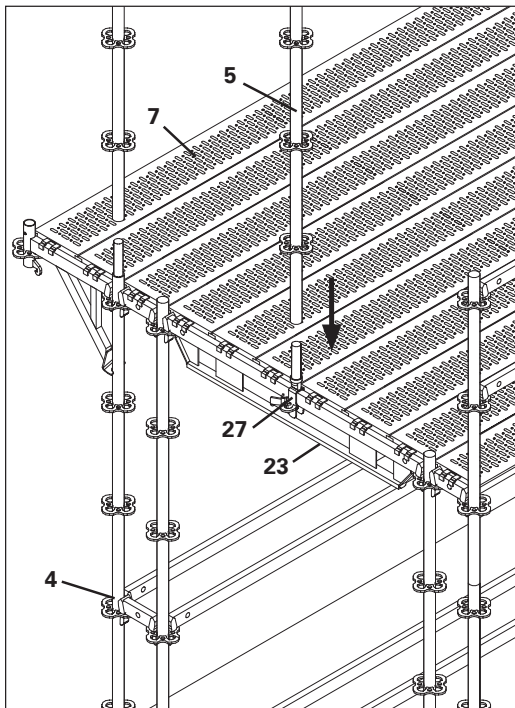

Fig.C5-1

Example subject to design, considering all possible loading combinations.

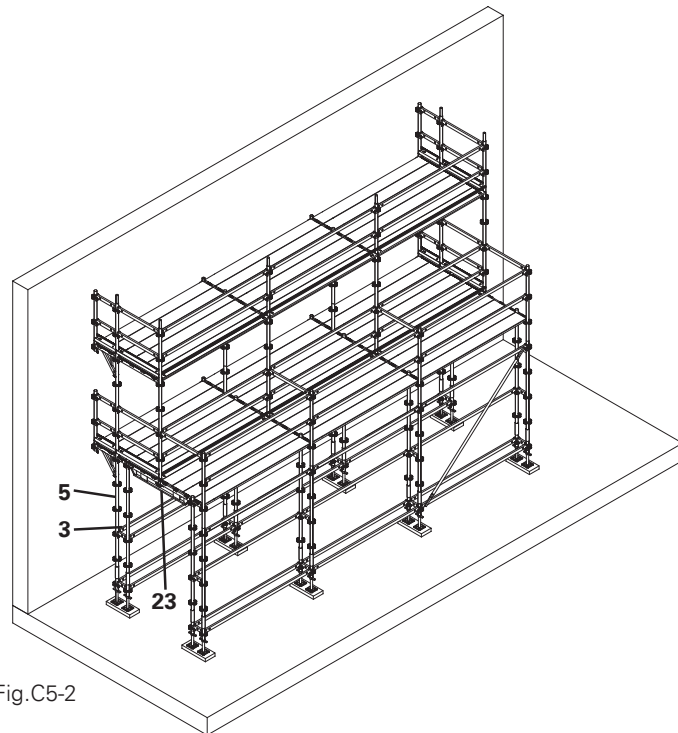

Fig.C5-2

Ledgers UHV can accommodate legs positioned at 0.25m increments without couplers clashing with stiffeners.

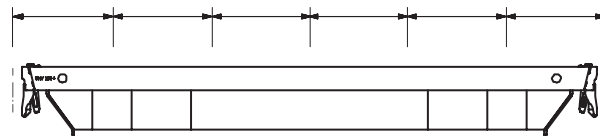

Fig.C5-3

PERI UP Rosett Flex Working Scaffold 100 with Deck UDI

C6 Circular Structures

C6.1 Using Bottom Sheeting UPD 100

Circular scaffolds can be achieved using PERI UP system components without the need for tube and couplers, resulting in a clear reduction in assembly time.

The Bottom Sheeting **UPD**100 (**18**) and Ledger to Ledger Coupler UHA (**26**) fit to the longitudinal Ledger UH (**4**). This allows for a 0.5m off-set between inner and outer legs. The next bay attaches to the leading leg, and is rotated to suit the required radius.

For internal radius scaffolds, the Bottom Sheeting UPD (**18**) and the Ledger to Ledger Coupler UHA (**26**) are positioned on the inner longitudinal Ledgers (**4**). Continuous guard rails are provided by lapping short length longitudinal Ledgers UH (**4**).

For external radius scaffolds, the Bottom Sheeting UPD (**18**) and the Ledger to Ledger Coupler UHA (**26**) are positioned on the outer longitudinal Ledgers UH (**4**).

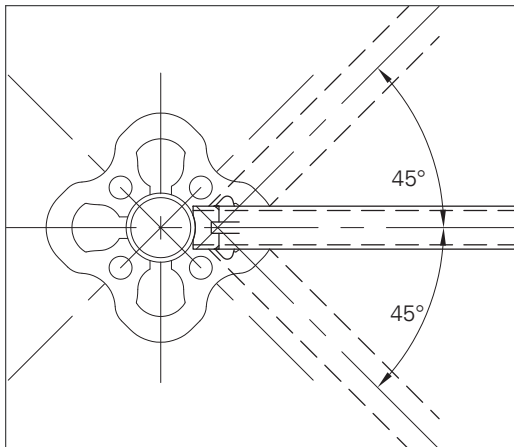

Fig.C6-2

The PERI UP Rosett allows for connecting Ledgers UH at up to 45° on plan.

Example subject to design, considering all possible loading combinations.

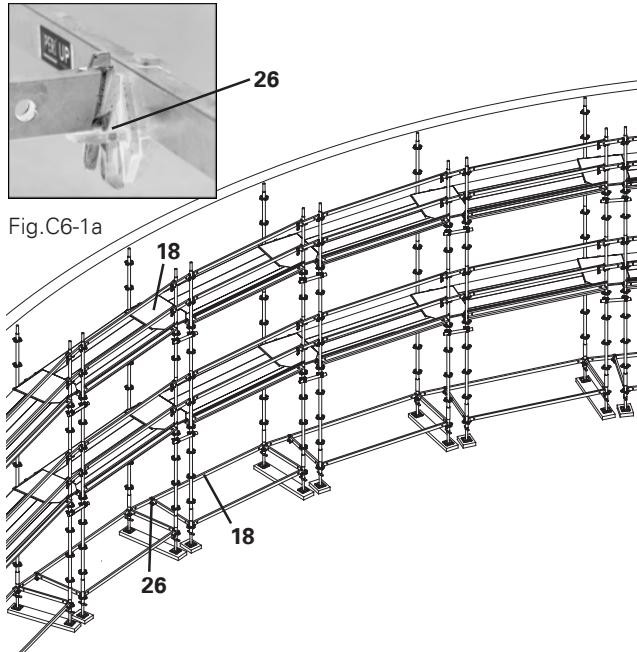

Fig.C6-1a

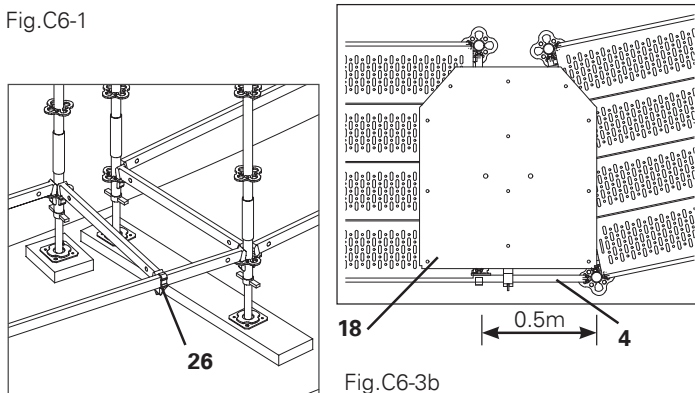

Fig.C6-1

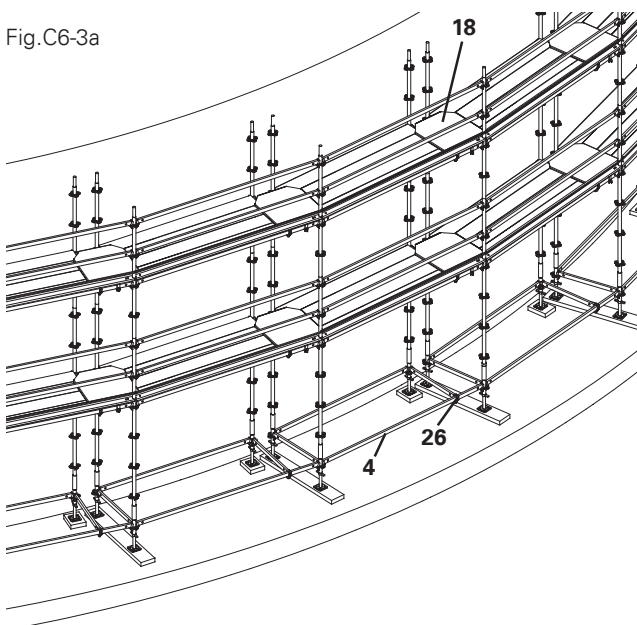

Fig.C6-3a

Fig.C6-3

PERI UP Rosett Flex Working Scaffold 100 with Deck UDI

C6 Circular Structures



C6.2 Using Corner Plate UDC

Smaller radius circular structures may be scaffolded using rectangular scaffolds. Corner Plates UDC 75 or 100 (**19**) are fitted to the Ledgers UH (**4**) to provide access platforms to the internal corners.

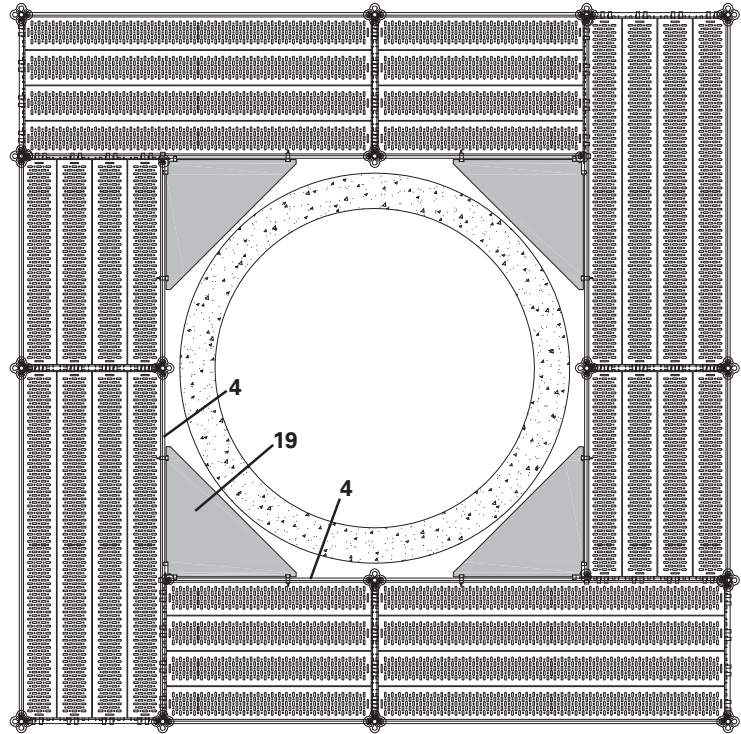

Fig.C6-4a

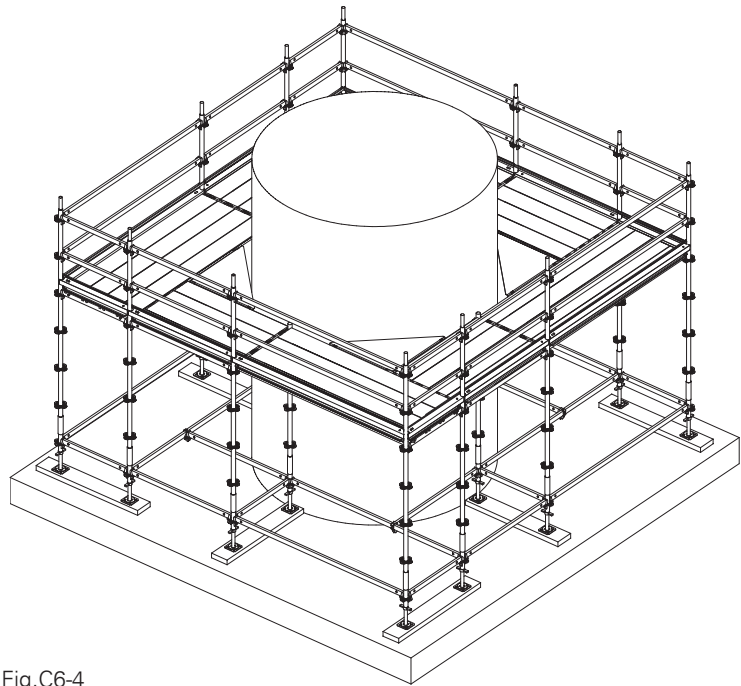

Fig.C6-4

PERI UP Rosett Flex Working Scaffold 100 with Deck UDI

C7 Fixed joints in standards

C7.1 Suspended / Tension Joints

C7.1.1 Suspended Scaffolds

Connecting Standard UVR (5) with Standard UVR / UVH (5) above using 1No M10 x 70-8.8 bolt & nut.

Use for secure fixing of joints in suspended scaffolds.

Permissible tension load = 19.7kN

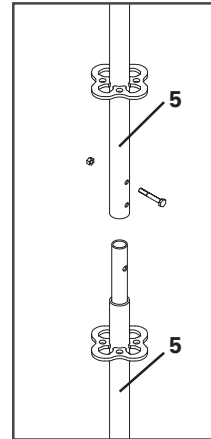

Fig.C7-1

C7.1.2 Tension Scaffolds

Connecting Standard UVR (5) with Standard UVR / UVH (5) above using 1No Locking Pin Ø 48, galv. (16).

Use for securing joints in crane handled & free standing scaffolds.

Permissible tension load = 14.2kN

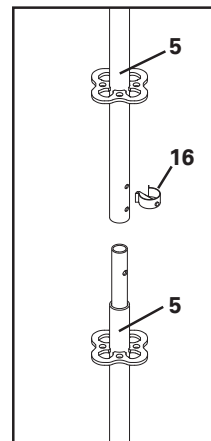

Fig.C7-2

PERI UP Rosett Flex Working Scaffold 100 with Deck UDI

C8 Untied Scaffolds



C8.1 Scaffolds on Ledger UHV

Untied craneable façade scaffolds may be created using the Ledger UHV.

The Ledger to Ledger Coupler UHA Half with Spigot (27) is fitted on the Ledger UHV at the outer scaffold leg position to receive Standards UVR (5). The Standards UVR (5) are braced down to the Ledger UHV (23) level by Coupler Braces UBC (32).

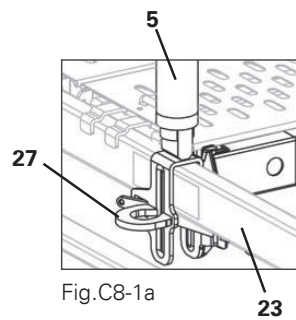

Fig.C8-1a

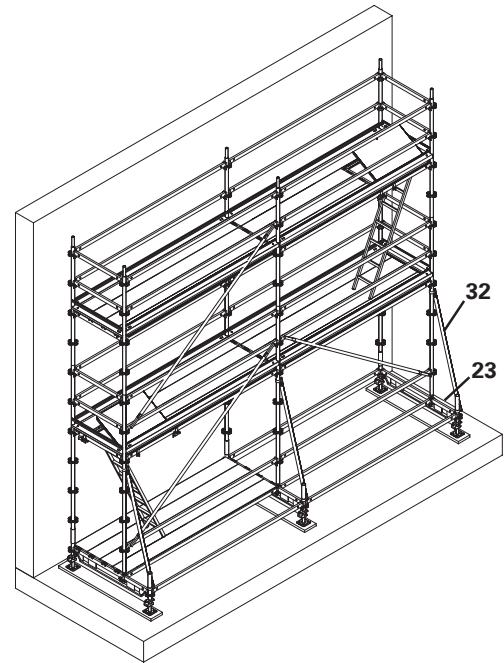

Fig.C8-1



For standard details refer to PERI UP Rosett Flex Reinforcement Scaffold with Deck UDI Assembly Instructions.

C8.2 Buttressed scaffolds

Untied façade scaffolds may also be created using buttress bays with anchorage to base or alternatively kentledge blocks.

Ledger Braces UBL (9) from the buttress bay to the outer leg may be connected to a Ledger UH 25 (4).

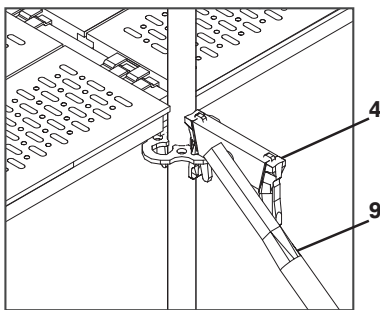

Fig.C8-2a

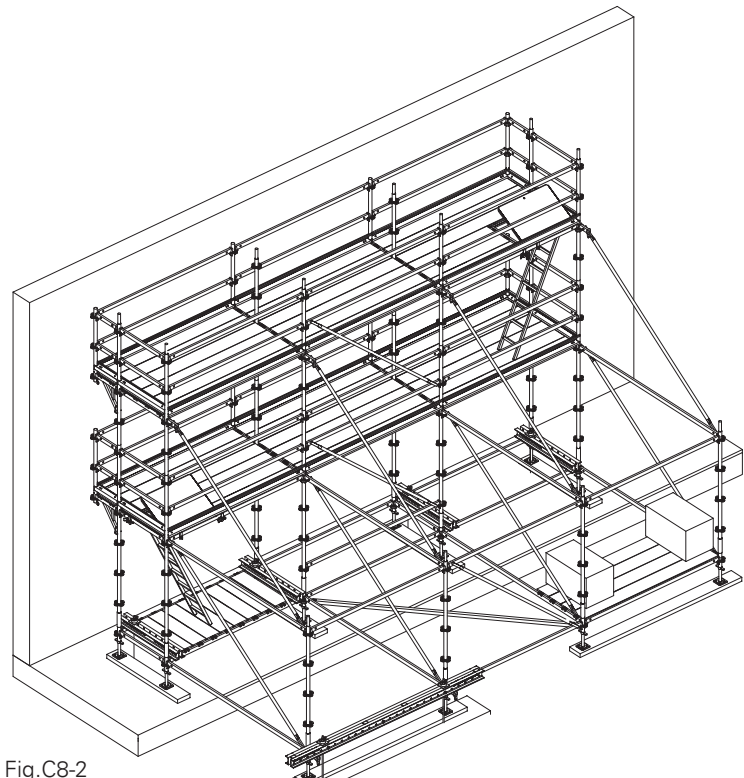

Fig.C8-2

Examples subject to design, considering all possible loading combinations.

PERI UP Rosett Flex Working Scaffold 100 with Deck UDI

C8 Untied Scaffolds



C8.3 Scaffolds stabilised with RSS Push-Pull Props

Untied façade scaffolds may be stabilised using PERI Push-Pull props.

RSS Push-Pull Props are connected to the vertical Standards UVR (5) with the Brace Connectors HDR and to base with Base Plate-2 for RSS.

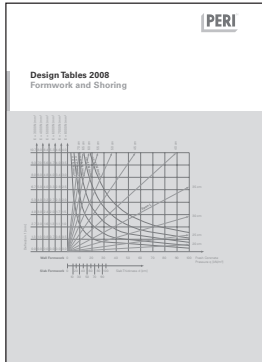

For prop and base fixing capacities refer to PERI Design Tables.

For HDR capacities refer PI 247

Example subject to design, considering all possible loading combinations.

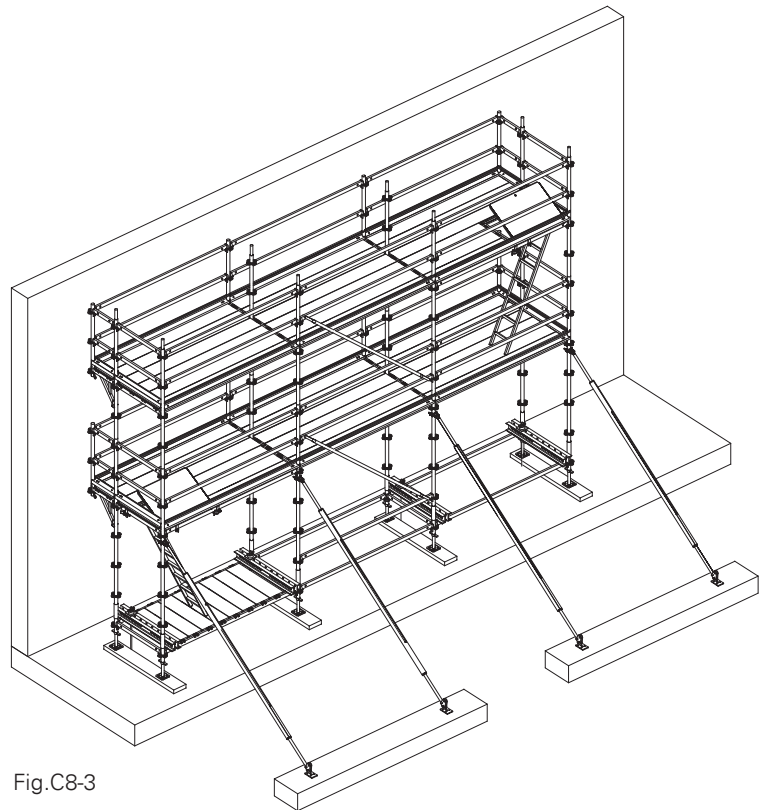

Fig.C8-3

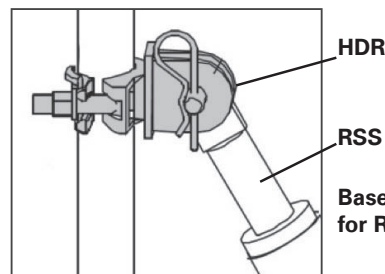

Fig.C8-3a

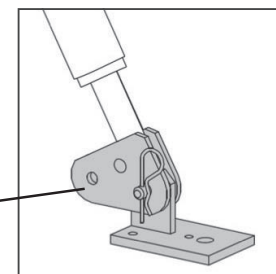

Fig.C8-3b

PERI UP Rosett Flex Working Scaffold 100 with Deck UDI

D Anchor Options

Standard tie pattern arrangements as set out in section B may not always be possible to achieve.

Alternative anchoring examples in this section may be used, depending on load case & use. Please contact your local PERI office for more information.

D.1 Unclad scaffold – top level not anchored

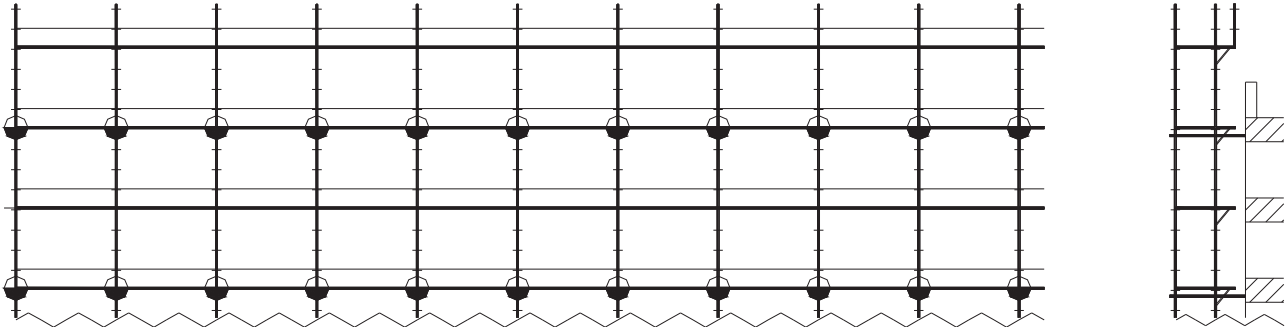



Fig.D1-1

 Wall tie fixed to both standards

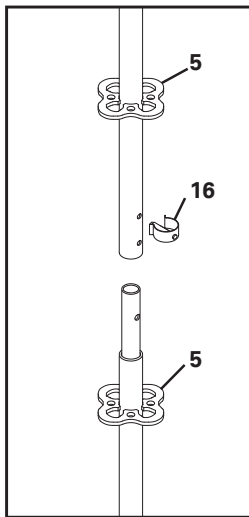

Fig.D1-2

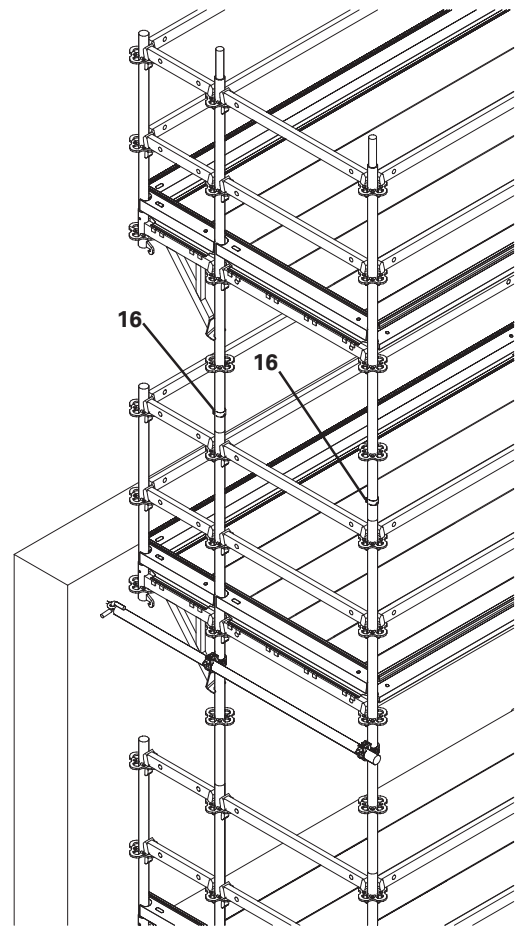

Fig.D1-3

Note: Only structural components are indicated. All other necessary guard rail ledgers / toe boards omitted for clarity.
Façade bracing is not required.

D Anchor Options

D.2 Anchor points between lifts on section

D2.1 Using Ledger UH25

Fit additional Vertical Standard UVR (5) to inner standard with 2 No Ledgers UH25 (3). Fit Wall Ties UWT (13) with single scaffold coupler to both inner standards.

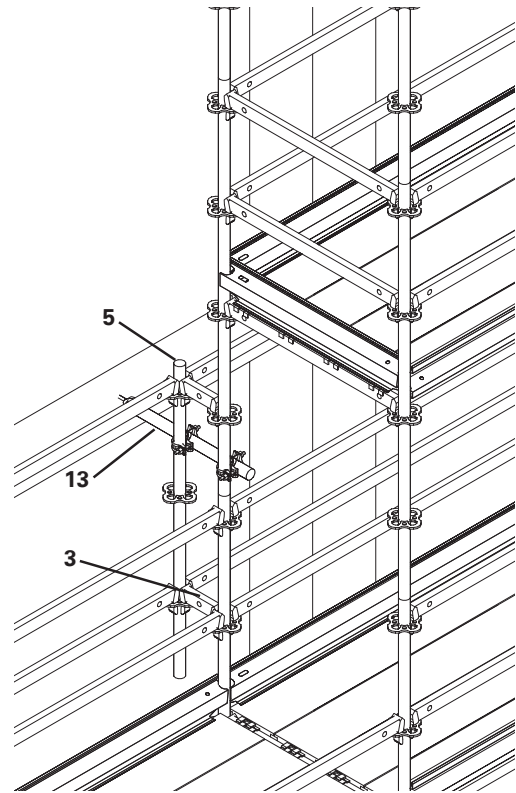

Fig.D2-1

D2.2 Using Standard UVH between UCM platforms

Fit Standard UVR (5) in to Console Bracket UCM (6) and connect to inner leg Standard UVR (5) with Ledgers UH 50 (4) at upper UDI Deck level. Fit Wall Ties UWT (13) with scaffold couplers to both inner standards.

(3d – UDI Decks partially omitted for clarity).

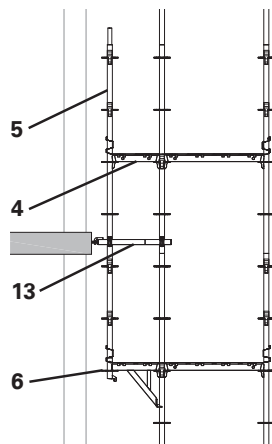

Fig.D2-2

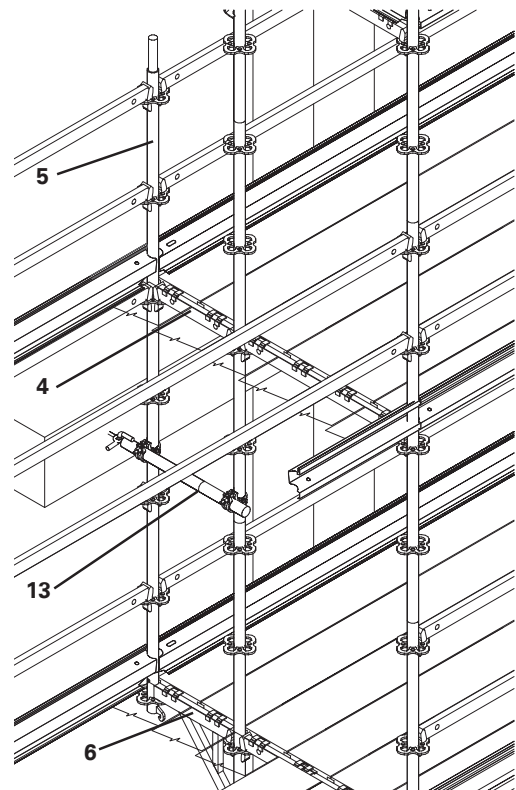

Fig.D2-3

Examples subject to design, considering all possible loading combinations.

D Anchor Options

D2.3 Using Wall Ties UWT Triangulated on Section

Connect to slabs with triangulated Wall Ties UWT (13) fitted to internal Standards UVR (5) with couplers fitted as close as possible to the platform levels.

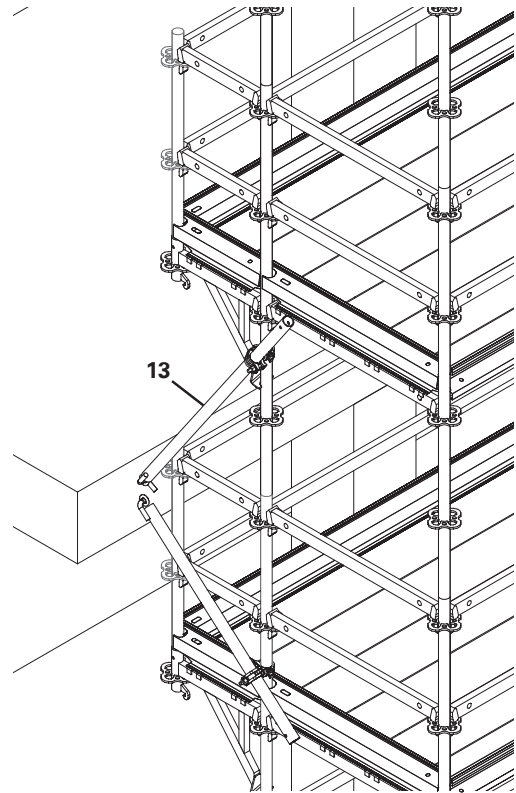

Fig.D2-4

D3 Anchor points between legs on plan

D3.1 Using Wall Ties UWT Triangulated on Plan

Pairs of legs may be tied to columns with triangulated Wall Ties UWT (13). Plan brace any untied legs using H-Brace UBH-Flex (8).

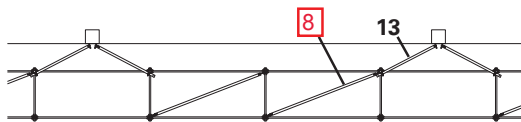

Fig.D2-5

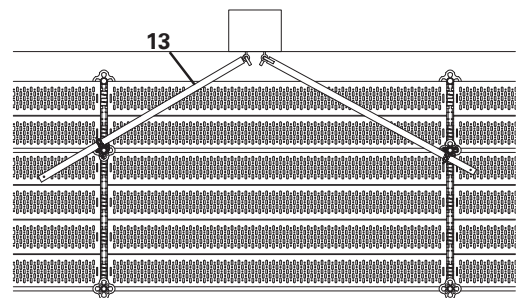

Fig.D2-6a

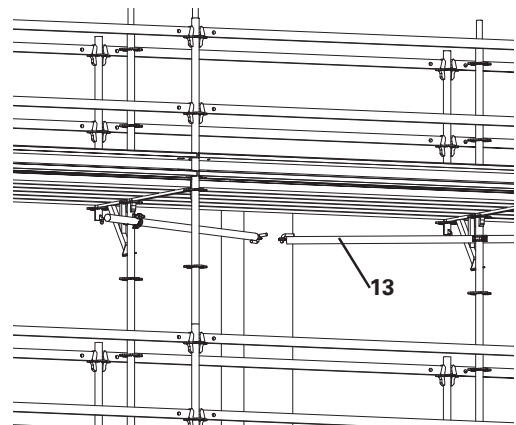

Fig.D2-6

Examples subject to design, considering all possible loading combinations.

E1 Connection points for safety harnesses

E1.1 Basic requirements

The erection sequence in section A allows for stringent safety measures to prevent the risk of falling during assembly, adjusting and dismantling work as far as they are recognisable and can be planned on the basis of a risk analysis.



In order to guarantee the provision of safety in use, the user has to carry out a site specific risk evaluation for each scaffold assembly and for each use of the scaffolding. Based on this, the user is obliged to implement appropriate safety measures.

E1.2 Attachment points on Standards UVH / UVR

- 1) At any Rosett within completed scaffold lifts
- 2) At any Rosett up to 1.0m above deck level.
- 3) Joint in Standard UVR is permitted above deck level.

E1.3 Attachment points on Ledgers UH

- A) At any Ledger UH connected between two Standards UVH / UVR within completed scaffold lifts
- B) At any Ledger UH connected between two Standards UVH / UVR up to 1.0m above deck level.

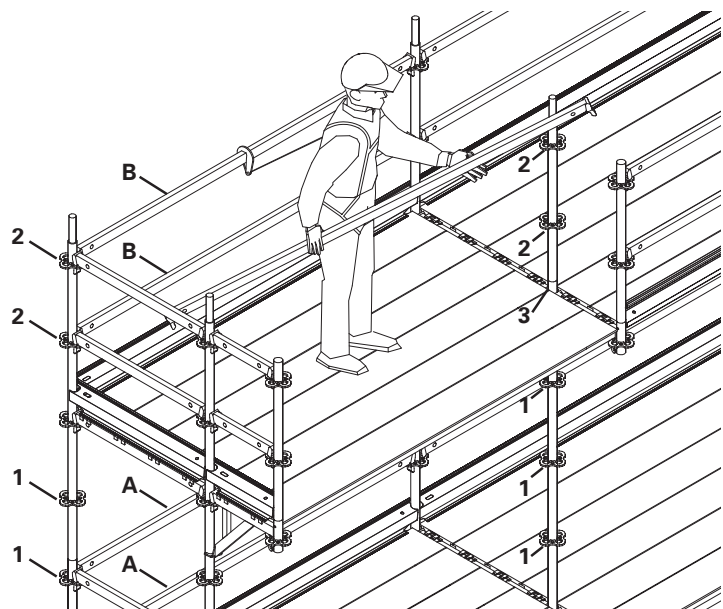

Fig.E1-1



Ledgers UH & Standards UVH / UVR on Console Brackets UCM must never be used as locations for fixing of safety harness!

X = Attachment not permissible!

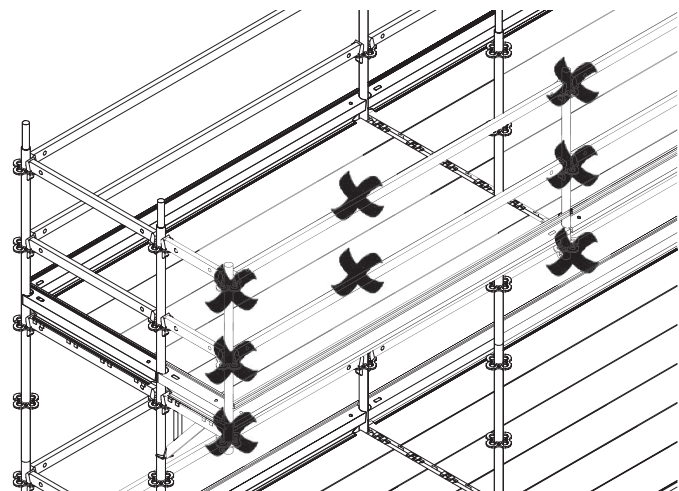

Fig.E1-2

PERI UP Rosett Flex Working Scaffold 100 with Deck UDI F Components

F1 Safe Storage

Components are supplied by PERI safely stacked, bound or stored in crates or pallets as appropriate. The customer must ensure that all components on site not in use or after use ready for return must be stored in the appropriate safe manner.

Examples of appropriate storage and quantities for common components are listed in this section. Contact your PERI delivery branch for details of components not listed.

Where possible, components should be separated using timber packs as illustrated:



Fig.F1-1

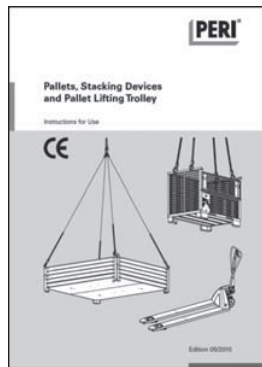

For safe use of PERI storage components, refer to Instructions for Use.



Fig.F1-2

F1.1 Independently Stacked Components

Larger components such as UDI Decks may be stacked independently of Pallets. Use timber packs and banding straps max. 5 wide x 12 high.

107002	Industrial Deck UDI 25 x 150	60
108380	Industrial Deck UDI 25 x 200	60
108540	Industrial Deck UDI 25 x 250	60
108689	Industrial Deck UDI 25 x 300	60



Fig.F1-3

F1.2 Accessory Boxes 80 x 120

Small accessory components may be stored in Accessory Boxes 80 x 120cm (capacity approx. 0.28m³):

Safety Instructions

Load-carrying capacity = 1.5t. Follow Instructions for Use.

Contact your PERI delivery branch for permissible quantities of accessories per box.

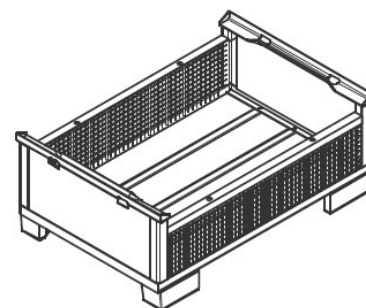

Fig.F1-4

PERI UP Rosett Flex Working Scaffold 100 with Deck UDI F Components

F1.3 Crate Pallets 80 x 120

Shorter components may be stored in Crate Pallet 80 x 120cm (capacity approx. 0.75m³) in quantities indicated below:

Safety Instructions

Load-carrying capacity = 1.5t. Follow Instructions for Use.

F1.3.1 Bases

100411	Adj. Base Plate UJB 38-50/30	250
100242	Adj. Base Plate UJB 38-80/55	140
019780	Base Spindle TR 38-70/50	140
100159	Adj. Base Plate UJS 38-80/5 Swivel	140
100014	Base Standard UVB 24	210

F1.3.2 Standards UVH / UVR

101309	Standard UVH 50	200
100000	Standard UVH 100	81
102859	Standard UVR 50	162
101306	Standard UVR 100	81

F1.3.3 Ledgers UH

104780	Ledger UH 25	600
104779	Ledger UH50	300
100017	Ledger UH75	256
114632	Ledger UH 100 Plus	150
114638	Ledger UH 125 Plus	105

F1.3.4 Industrial Decks UDI

104029	Industrial Deck UDI 25 x 50	42
105925	Industrial Deck UDI 25 x 75	42

F1.3.5 Toe Boards Steel UPY (Not illustrated)

110514	Toe Board Steel UPY 75	90
110073	Toe Board Steel UPY 100	90

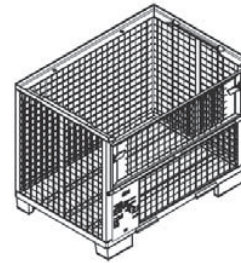

Fig.F1-5



Fig.F1-6

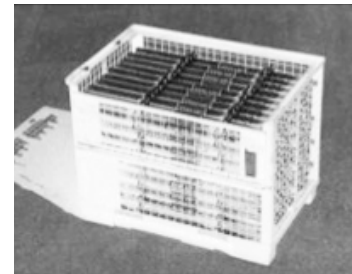

Fig.F1-7



Fig.F1-8



Fig.F1-9

PERI UP Rosett Flex Working Scaffold 100 with Deck UDI F Components

F1.4 Pallets RP-2

Longer components may be stored in Pallet RP-2 80 x 120cm or 80 x 150cm in quantities indicated below:

Safety Instructions

Load-carrying capacity = 1.5t. Follow Instructions for Use.

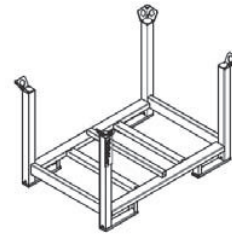

Fig.F1-10

F1.4.1 Standards UVH / UVR

100003	Standard UVH 150	56
100005	Standard UVH 200	56
100007	Standard UVH 250	56
100009	Standard UVR 150	56
100012	Standard UVR 300	56
100013	Standard UVR 400	56

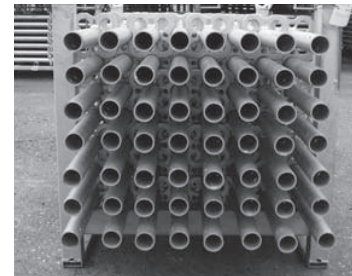

Fig.F1-11

F1.4.2 Ledgers UH

100021	Ledger UH 150	108
100023	Ledger UH 200	108
100025	Ledger UH 250	108
100027	Ledger UH 300	108

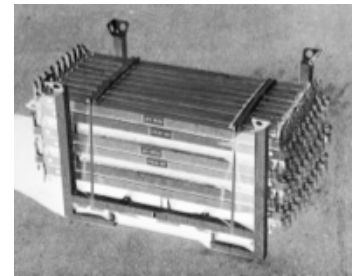

Fig.F1-12

F1.4.3 Ledgers Braces UBL

115513	Ledger Brace UBL 100/150	135
100057	Ledger Brace UBL 150/200	135
100061	Ledger Brace UBL 200/200	135
100065	Ledger Brace UBL 250/200	135
100069	Ledger Brace UBL 300/200	135



Fig.F1-13

F1.4.4 Toe Boards Steel UPY

110160	Toe Board Steel UPY 150	90
110176	Toe Board Steel UPY 200	90
110208	Toe Board Steel UPY 250	90
110211	Toe Board Steel UPY 300	90

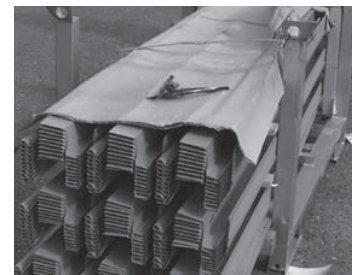

Fig.F1-14

Item no. Weight kg

104305 2,780 Adj. Base Plate UJB 38-27/17



Note

With captive white Quick Jack Nut.

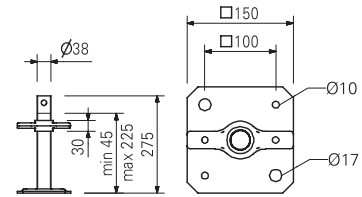

100411 3,330 Adj. Base Plate UJB 38-50/30

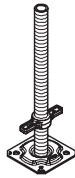

Note

With captive red Quick Jack Nut.

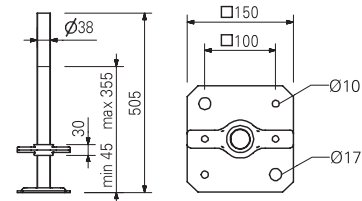

100242 4,520 Adj. Base Plate UJB 38-80/55

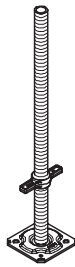

Note

With captive yellow Quick Jack Nut.

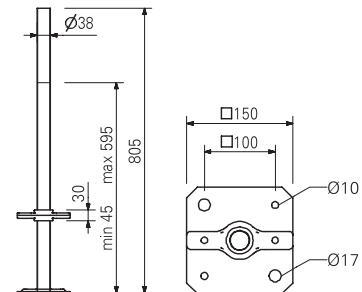

019780 5,160 Base Spindle TR 38-70/50

For heavily loaded shoring.

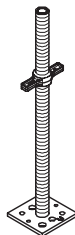

Note

With captive Quick Jack Nut.

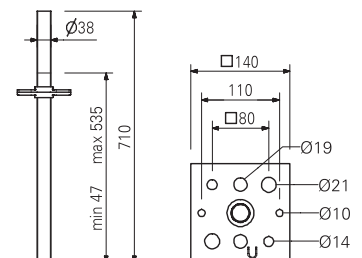

Item no.	Weight kg
100159	4,860

Adj. Base Plate UJS 38-80/50 Swivel

Note

With captive yellow Quick Jack Nut.

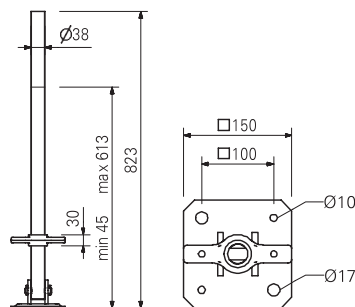
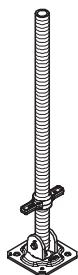

100244	1,230
--------	-------

Base Plate UJP

Without height adjustment.

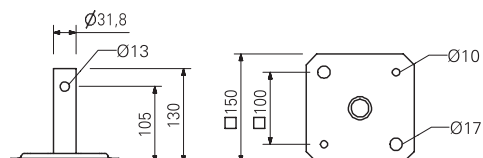
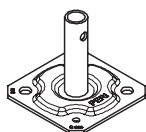

100863	1,030
--------	-------

Spindle Locking UJS

Secures the adjustable base plates \varnothing 38 mm in the leg when moving.

Note

Wrench size SW 19.

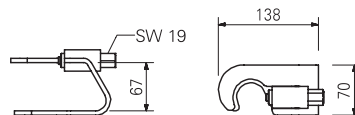

100014	2,470
--------	-------

Base Standard UVB 24

For assembly directly on the base spindle.

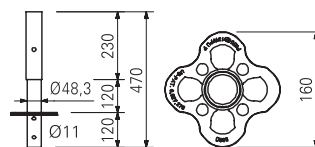

117194	3,980
--------	-------

Base Standard UVB 49

For assembly directly on the base spindle.
Reduces necessary spindle extension lengths through distance between rosettes of 25 cm.

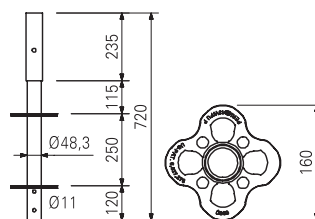

Item no. Weight kg

Item no.	Weight kg	Standards UVR	L
102859	3,080	Standard UVR 50	500
101306	5,380	Standard UVR 100	1000
102860	7,690	Standard UVR 150	1500
100009	9,990	Standard UVR 200	2000
100012	14,700	Standard UVR 300	3000
100013	19,200	Standard UVR 400	4000

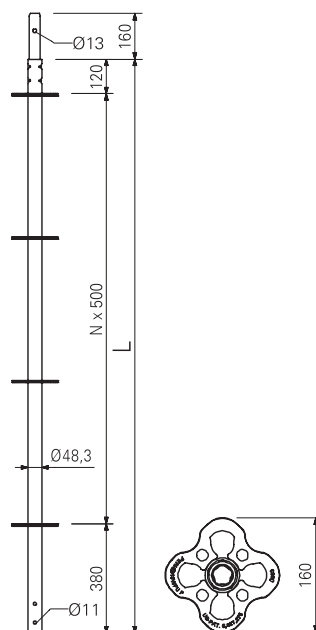

Item no.	Weight kg	Top Standards UVH	L
101309	2,510	Top Standard UVH 50	500
100000	4,610	Top Standard UVH 100	1000
100003	6,920	Top Standard UVH 150	1500
100005	9,230	Top Standard UVH 200	2000
100007	11,500	Top Standard UVH 250	2500

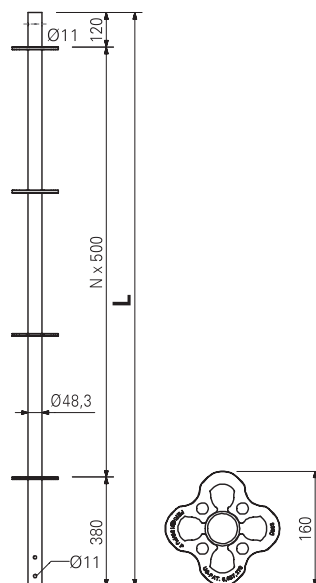

Without spigot for supporting head spindles.

Item no.	Weight kg
117195	7,590

Top Standard UVH 125

Without spigot for supporting head spindles.
Reduces necessary spindle extension lengths through distance between rosettes of 25 cm.

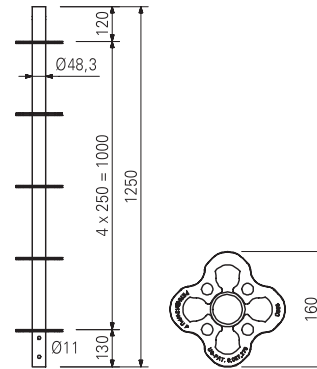

		Ledgers UH
104780	1,390	Ledger UH 25
104779	2,040	Ledger UH 50
100017	2,710	Ledger UH 75
101159	3,370	Ledger UH 100
110347	4,020	Ledger UH 125
100021	4,690	Ledger UH 150
100023	6,020	Ledger UH 200
100025	7,340	Ledger UH 250
100027	8,670	Ledger UH 300
100029	11,300	Ledger UH 400

L	X	Sticker
204	250	
454	500	
704	750	White
954	1000	White
1204	1250	
1454	1500	
1954	2000	White
2454	2500	Red
2954	3000	Black
3954	4000	

Note

Only available as rentable item.
Longitudinally-stamped with coloured label for easier identification.
Ledgers UH can be replaced by ledgers UH Plus.

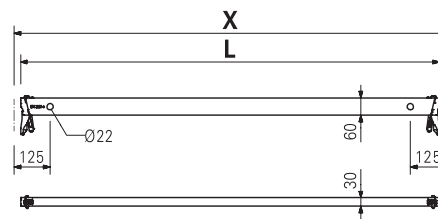
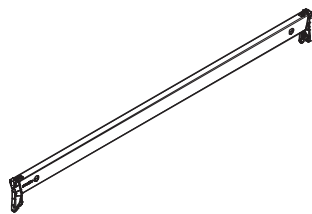

Item no.	Weight kg
114613	1,430
114595	2,080
114629	2,760
114632	4,490
114638	5,450
114641	4,730
117032	5,390
114645	6,060
116356	6,720
114648	7,380
114651	8,700
114654	11,300

Ledgers UH Plus
Ledger UH 25 Plus
Ledger UH 50 Plus
Ledger UH 75 Plus
Ledger UH 100 Plus
Ledger UH 125 Plus
Ledger UH 150 Plus
Ledger UH 175 Plus
Ledger UH 200 Plus
Ledger UH 225 Plus
Ledger UH 250 Plus
Ledger UH 300 Plus
Ledger UH 400 Plus

L	X	Sticker
204	250	
454	500	
704	750	White
954	1000	White
1204	1250	
1454	1500	
1704	1750	
1954	2000	White
2204	2250	
2454	2500	Red
2954	3000	Black
3954	4000	

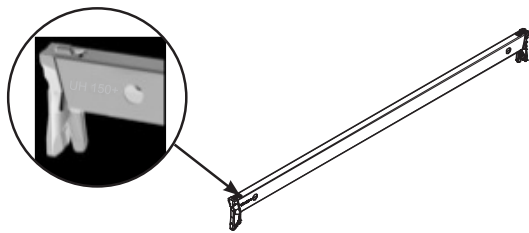

See stamp for identification of UH Ledger Plus

Note

Longitudinally-stamped with coloured label for easier identification.

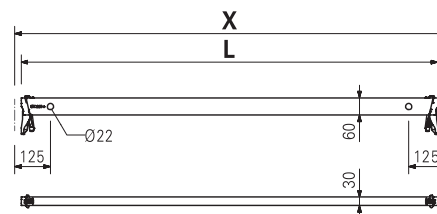

109107	10,900
109108	14,800
109109	18,000
109110	21,800

Ledgers UHV
Ledger UHV 150
Ledger UHV 200
Ledger UHV 250
Ledger UHV 300

For high loads, e.g. material storage.

L	X
1454	1500
1954	2000
2454	2500
2954	3000

Note

Only available as rentable item.
 Ledgers UHV can be replaced by Ledgers UHV Plus.

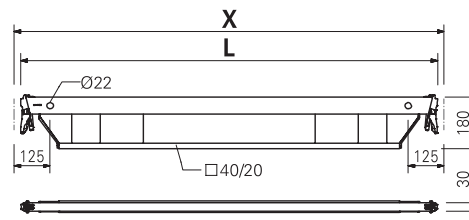
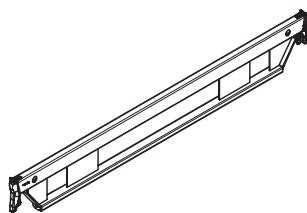

114681	11,000
114687	14,900
114691	18,100
114695	21,800

Ledgers UHV Plus
Ledger UHV 150 Plus
Ledger UHV 200 Plus
Ledger UHV 250 Plus
Ledger UHV 300 Plus

For high loads, e.g. material storage.

L	X
1454	1500
1954	2000
2454	2500
2954	3000

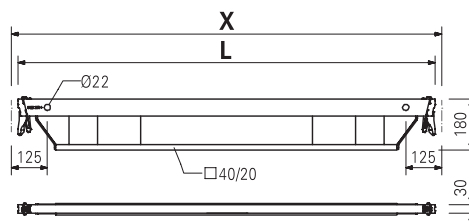
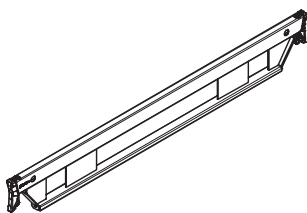

Item no.	Weight kg
----------	-----------

110807	12,600
110815	15,300

Ledgers UHV-L

Ledger UHV-L 250

Ledger UHV-L 300

Lightweight waler preferred for cantilevers.

Note

Only available as rentable item.

Ledgers UHV-L can be replaced by ledgers UHV-L Plus.

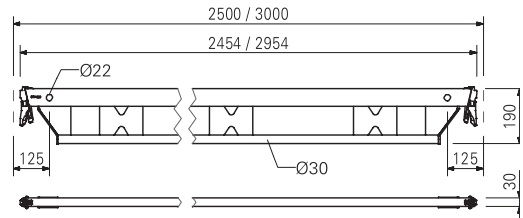
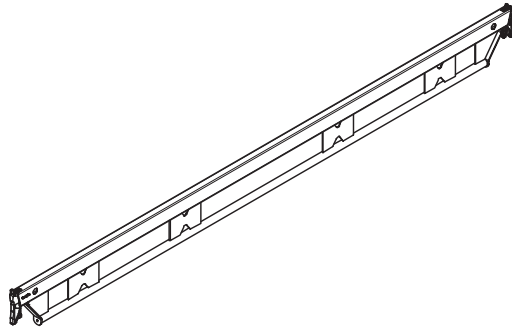

114699	12,700
114718	15,300

Ledgers UHV-L Plus

Ledger UHV-L 250 Plus

Ledger UHV-L 300 Plus

Lightweight waler preferred for cantilevers.

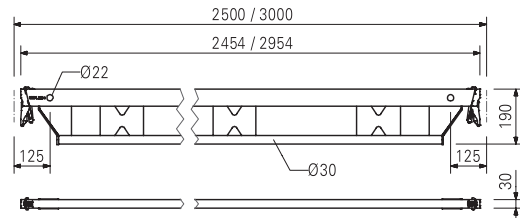
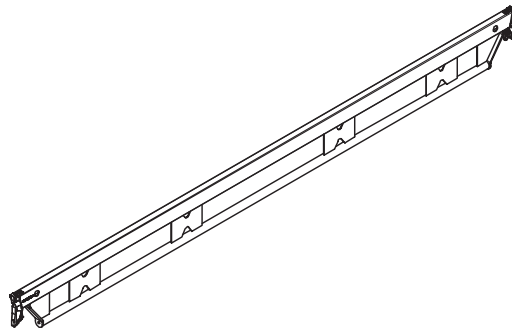

101731	0,841
--------	-------

Ledger to Ledger Coupler UHA

For connecting ledger to ledger at right-angles.

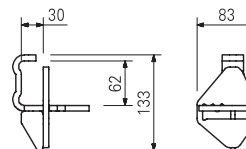

110793	1,090
--------	-------

Ledger to Ledger Coupler UHA Half

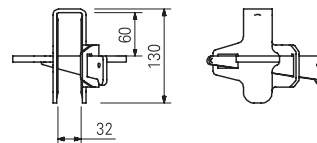
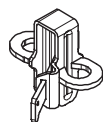

Item no. Weight kg

110792 1,880 **Ledger to Ledger Coupler UHA Half w. Spigot**

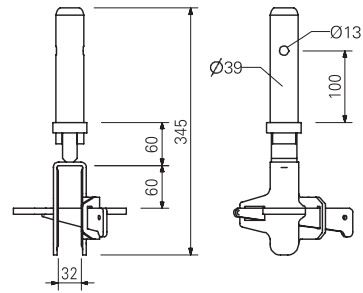
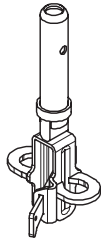

109764 1,220

Spigot UH

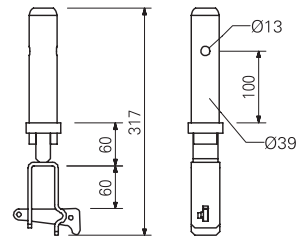
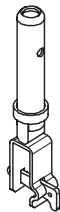

116306 1,680

Rosett Coupler UEV

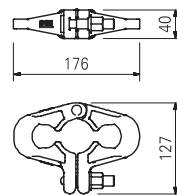

Item no. Weight kg

111053 0,059 **Locking Pin Ø 48/57**

As tension-proof connection of standards with a diameter of 48 up to 57 mm.

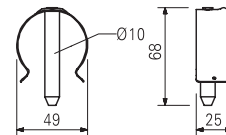

Item no.	Weight kg	L	X	Y	Sticker	
		Ledger Braces UBL				
019940	2,290	1250	1000	1000		
115513	5,390	1677	1000	1500		
100055	4,450	1601	1500	1000		
102846	5,350	1953	1500	1500		
100057	6,390	2358	1500	2000		
109034	6,750	2500	1750	2000		
104391	5,010	1820	2000	500		
100059	5,510	2016	2000	1000		
102862	6,250	2305	2000	1500		
100061	7,160	2658	2000	2000	White	
117689	7,590	2829	2250	2000		
100063	6,650	2462	2500	1000		
102861	7,270	2705	2500	1500		
100065	8,050	3010	2500	2000	Red	
104762	7,500	2795	3000	500		
100067	7,840	2926	3000	1000		
104766	8,370	3133	3000	1500		
100069	9,050	3400	3000	2000	Black	

Attach using holes in the ledgers.

Note

Longitudinally-stamped with coloured label for easier identification.

UBL 150/250 identical to UBL 300/50,
 UBL 225/150 identical to UBL 175/200,
 UBL 250/50 identical to UBL 200/150,

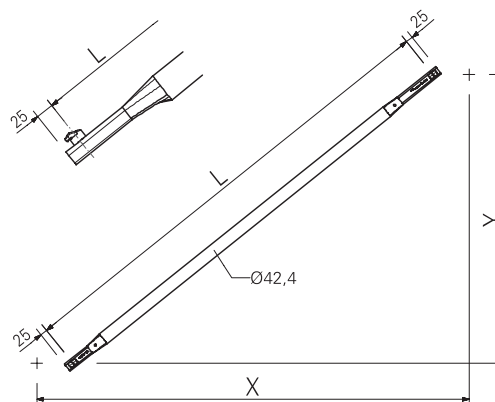
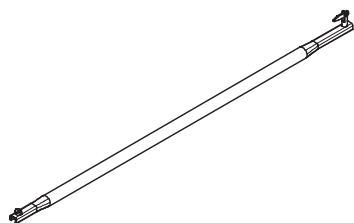

Item no.	Weight kg		L	X	Y
		H-Braces UBH Flex			
114818	4,580	H-Brace UBH Flex 100/100	1335	1000	1000
114904	5,620	H-Brace UBH Flex 125/125	1689	1250	1250
114821	5,720	H-Brace UBH Flex 150/100	1725	1500	1000
114908	6,160	H-Brace UBH Flex 150/125	1874	1500	1250
114912	6,650	H-Brace UBH Flex 150/150	2042	1500	1500
114820	7,000	H-Brace UBH Flex 200/100	2161	2000	1000
114916	8,730	H-Brace UBH Flex 200/200	2749	2000	2000
114896	8,120	H-Brace UBH Flex 250/75	2541	2500	750
114819	8,350	H-Brace UBH Flex 250/100	2620	2500	1000
114996	8,640	H-Brace UBH Flex 250/125	2720	2500	1250
114920	9,830	H-Brace UBH Flex 250/200	3123	2500	2000
114928	10,800	H-Brace UBH Flex 250/250	3456	2500	2500
114900	9,540	H-Brace UBH Flex 300/75	3025	3000	750
114892	9,730	H-Brace UBH Flex 300/100	3092	3000	1000
114924	11,000	H-Brace UBH Flex 300/200	3528	3000	2000
114932	11,900	H-Brace UBH Flex 300/250	3826	3000	2500
114936	12,900	H-Brace UBH Flex 300/300	4163	3000	3000

For horizontal bracing of towers. Useable also underneath the decking.

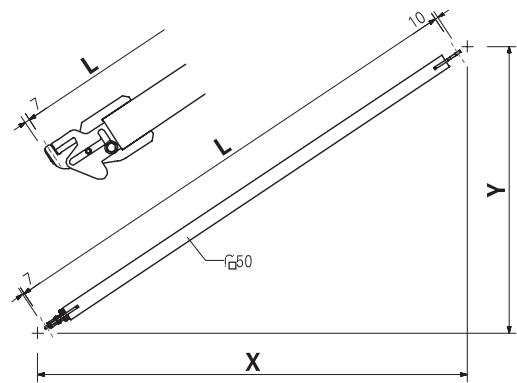
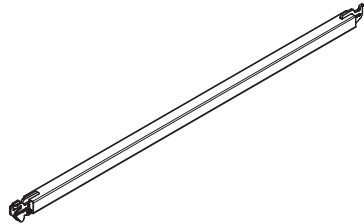

Item no. Weight kg

Item no.	Weight kg	Node Braces UBK	L	X	Y	Sticker
112926	6,990	Node Brace UBK 100/200	2285	1000	2000	
115354	5,220	Node Brace UBK 125/100	1625	1250	1000	
112765	7,260	Node Brace UBK 125/200	2401	1250	2000	
100981	5,710	Node Brace UBK 150/100	1821	1500	1000	
100973	6,580	Node Brace UBK 150/150	2152	1500	1500	
100572	7,600	Node Brace UBK 150/200	2539	1500	2000	
100985	6,790	Node Brace UBK 200/100	2246	2000	1000	
106630	7,510	Node Brace UBK 200/150	2521	2000	1500	
100573	8,390	Node Brace UBK 200/200	2860	2000	2000	White
100989	7,940	Node Brace UBK 250/100	2696	2500	1000	
106624	8,540	Node Brace UBK 250/150	2930	2500	1500	
100574	9,310	Node Brace UBK 250/200	3226	2500	2000	Red
100993	9,130	Node Brace UBK 300/100	3131	3000	1000	
100575	10,300	Node Brace UBK 300/200	3625	3000	2000	Black

For hooking into the small hole of the rosett

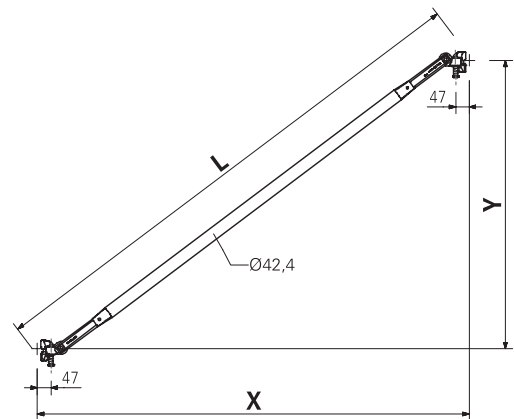
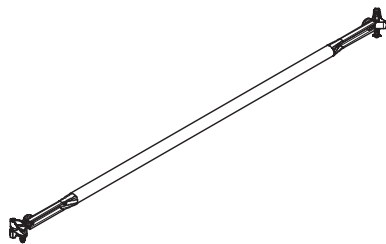

Item no.	Weight kg	Industrial Decks UDI 25	X	perm. p [kN/m ²]	max. p [kN/m ²]
104029	4,090	Industrial Deck UDI 25 x 50	500	6,0	40,0
105925	5,520	Industrial Deck UDI 25 x 75	750	6,0	26,7
106092	6,950	Industrial Deck UDI 25 x 100	1000	6,0	20,0
106880	8,380	Industrial Deck UDI 25 x 125	1250	6,0	16,0
107002	9,790	Industrial Deck UDI 25 x 150	1500	6,0	13,3
108380	12,700	Industrial Deck UDI 25 x 200	2000	6,0	10,0
108540	15,500	Industrial Deck UDI 25 x 250	2500	4,5	8,0
108689	18,400	Industrial Deck UDI 25 x 300	3000	3,0	6,3

Mounted on Ledgers or Consoles

Note

perm. p according to DIN EN 12811-1.
max. p = maximum possible load without deflection limitation.

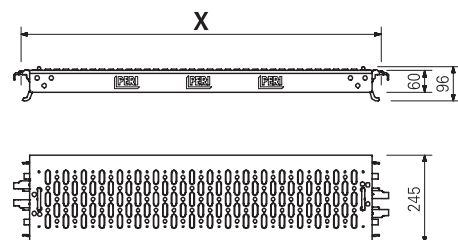
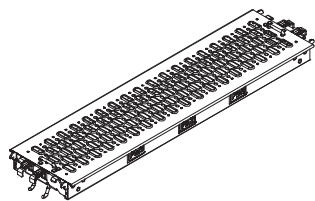

Item no.	Weight kg
111011	0,797

Deck Link Plate UDC

Connects two adjacent Industrial Decks UDI

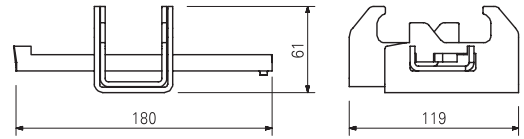
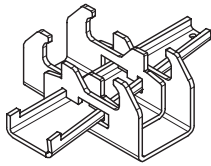

111101	7,780
112809	10,900

Bottom Sheetings UDP

Bottom Sheeting UDP 75

Bottom Sheeting UDP 100

Closes gaps between bays during scaffold installation on circular structures.

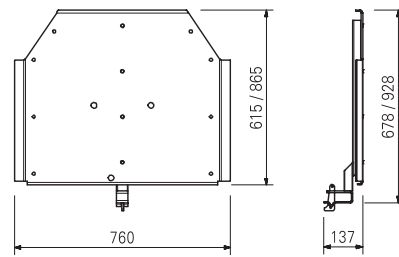
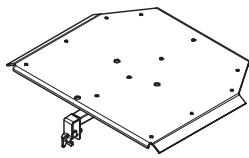

Item no.	Weight kg
114148	4,890
113358	10,000

Corner Plate UDC
Corner Plate UDC 75
Corner Plate UDC 100
 For internal corners of platforms on circular containers.

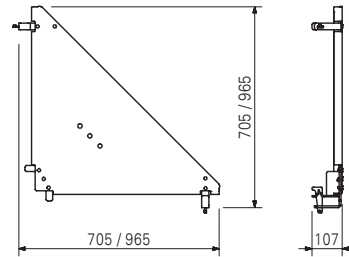

109783	9,710
109755	16,200

Hatches UAF
Hatch UAF 50 x 75
Hatch UAF 75 x 100

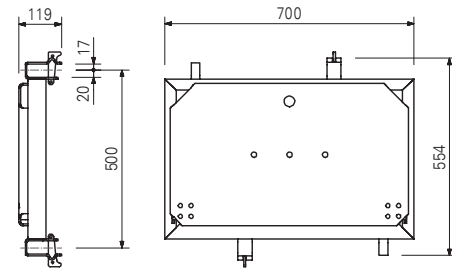
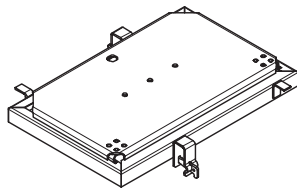

109879	3,820
--------	-------

Ladder UAF 200
 For mounting to Hatch UAF.

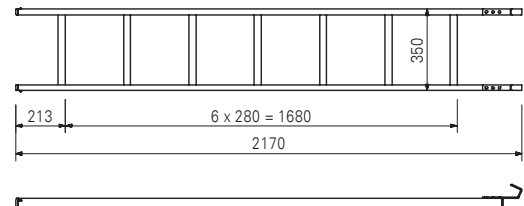
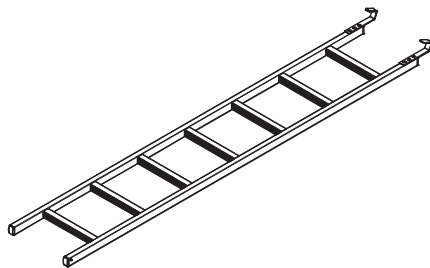

Item no.	Weight kg
114676	23,000

Access Deck UAL-2 75 x 250/3

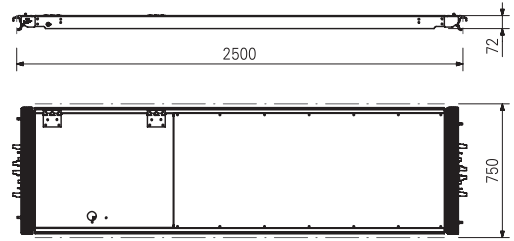
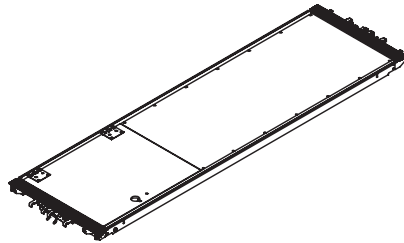

110213	0,927
110514	1,440
110073	1,960
110160	3,000
110176	4,030
110208	5,060
110211	6,100

Toe Boards Steel UPY
Toe Board Steel UPY 50
Toe Board Steel UPY 75
Toe Board Steel UPY 100
Toe Board Steel UPY 150
Toe Board Steel UPY 200
Toe Board Steel UPY 250
Toe Board Steel UPY 300

L	X
486	500
736	750
986	1000
1486	1500
1986	2000
2486	2500
2986	3000

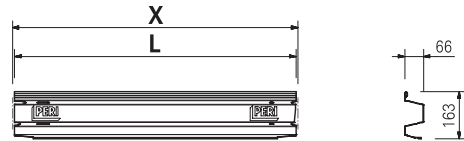
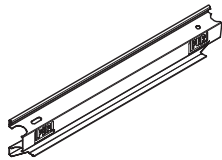

Item no.	Weight kg
110072	5,060
116695	5,640
117192	5,310

Swing Ledgers UPK
Swing Ledger UPK 75
Swing Ledger UPK 100
Swing Ledger UPK 125
 Upwards opening ledger.

L	X
704	750
954	1000
1204	1250

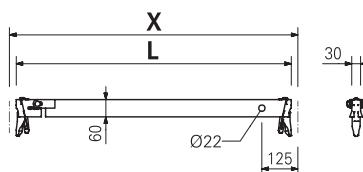
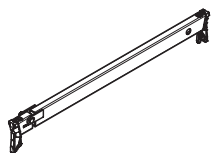

110478	5,120
116691	5,900

Swing Gates UPX
Swing Gate UPX 100
Swing Gate UPX 125

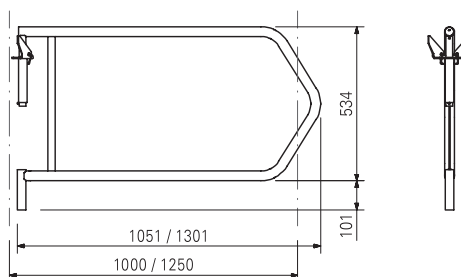
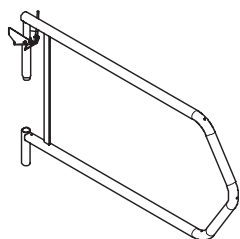

115959	1,150
--------	-------

Supports UC
Support UC 25

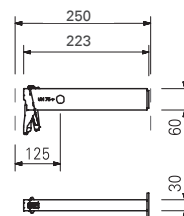
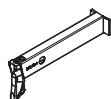

Item no.	Weight kg
----------	-----------

110483	4,490
111128	5,720

Consoles UCM
Console UCM 50-2
Console UCM 75-2

With connection for Console Bracket Brace UCM.

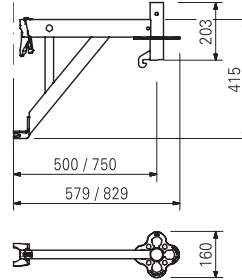
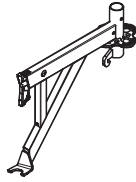

112676	5,280
112678	6,510

Consoles UCM with Spigot
Console UCM 50 with Spigot
Console UCM 75 with Spigot

With connection for Console Bracket Brace UCM.

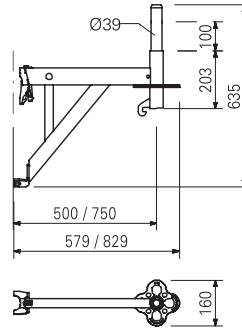
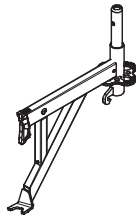

112690	4,390
112693	5,620

Consoles UCM with half Rosett
Console UCM 50 with half Rosett
Console UCM 75 with half Rosett

With connection for Console Bracket Brace UCM.

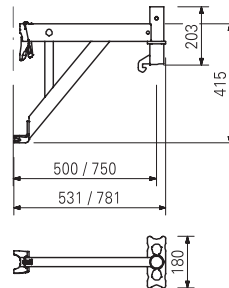
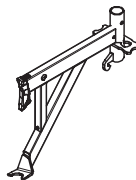

Item no.	Weight kg
112717	7,000

Console Bracket Brace UCM

For increasing the load-carrying capacity of
Consoles UCM 50 and UCM 75

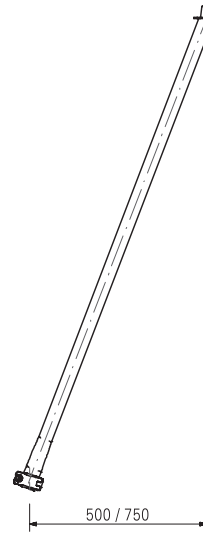
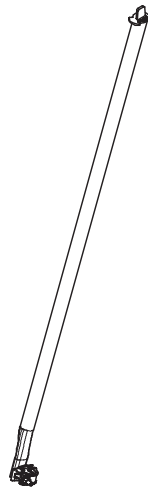

111117	28,100
111124	33,100

Staircases UAS 75

Staircase UAS 75 x 250/200, Alu

Staircase UAS 75 x 300/200, Alu

, Mounted on Ledgers or Consoles

Technical Data

Permissible load 2.0 kN/m².

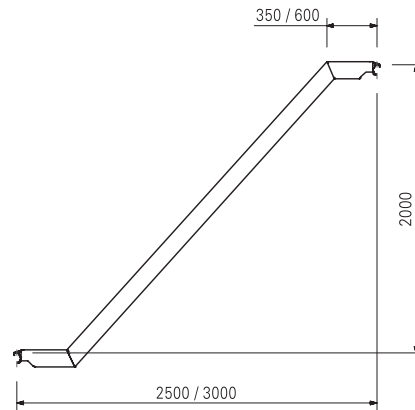
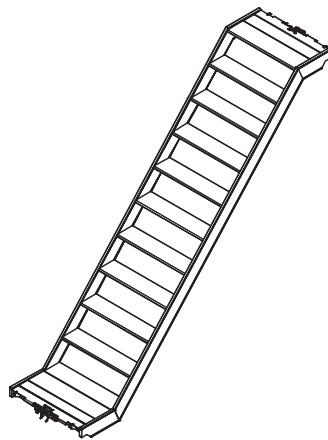

Item no.	Weight kg
113228	10,100

Staircase UAS 75 x 75/50
Mounted on Ledgers or Consoles

Technical Data
Permissible load 2.0 kN/m².

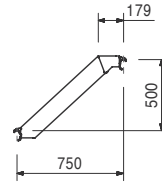
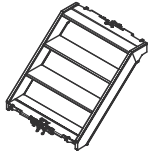

111087	17,600
--------	--------

Staircase UAS 75 x 150/50 T, Alu
Mounted on Ledgers or Consoles

Technical Data
Permissible load 2.0 kN/m².

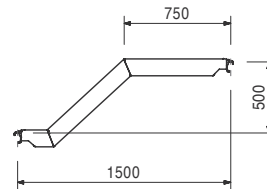
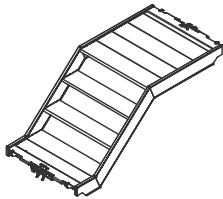

111095	17,600
--------	--------

Staircase UAS 75 x 150/50 S, Alu
Mounted on Ledgers or Consoles

Technical Data
Permissible load 2.0 kN/m².

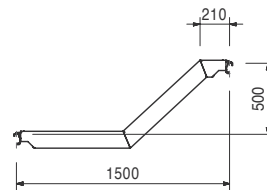
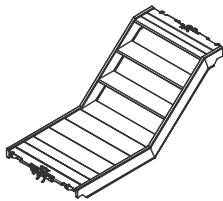

111103	17,900
--------	--------

Staircase UAS 75 x 150/100 T, Alu
Mounted on Ledgers or Consoles

Technical Data
Permissible load 2.0 kN/m².

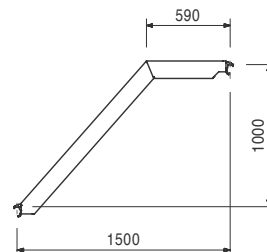
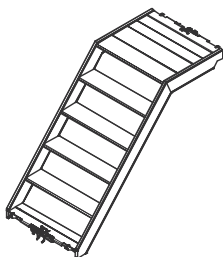

Item no.	Weight kg
114536	18,000

Staircase UAS 75 x 150/100 S, Alu
 Mounted on Ledgers or Consoles

Technical Data
 Permissible load 2.0 kN/m².

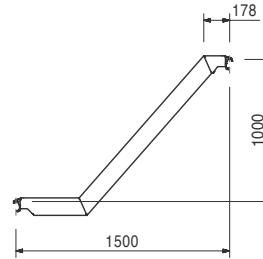
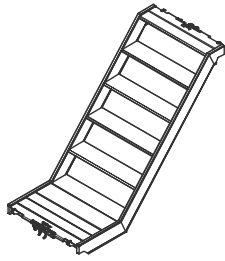

115189	3,080
--------	-------

Ledger on Staircase UAS 75
 Mounted on the treads of the staircase. Allows installation of Industrial Decks Steel UDI.

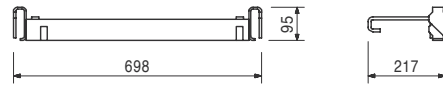
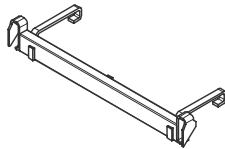

100742	10,000
--------	--------

Stair Guardrail UAG
 Suitable for Staircase UAS 75 x 250/200 and UAS 75 x 300/200 as internal and external guardrails.

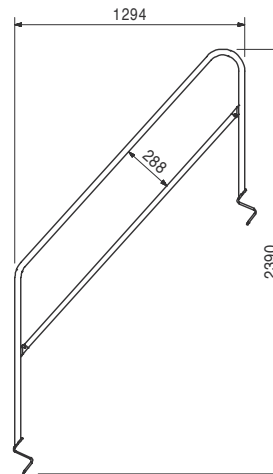
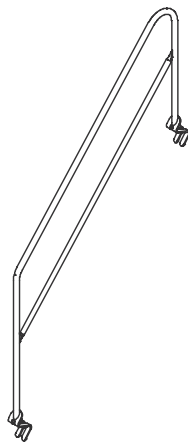

Item no.	Weight kg
100830	4,960

Stair Guardrail UAH

For fixing to the stringers of the Staircase Units
UAS 75 x 250/200, UAS 75 x 300/200.

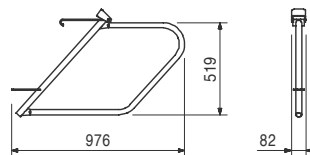
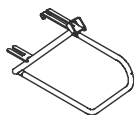

114731	9,800
109219	15,800

Stair Stringers UA

Stair Stringer UA 125/100

Stair Stringer UA 250/200

Technical Data

Permissible load 3.0 kN/m².

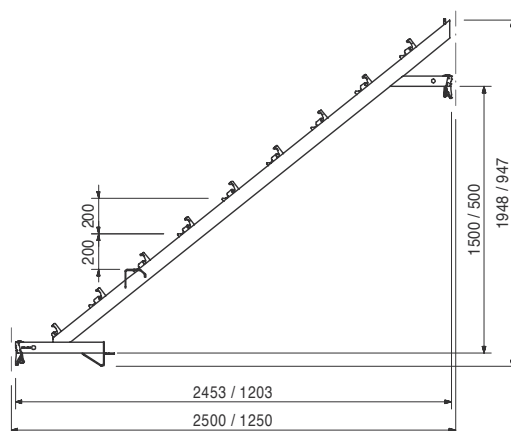
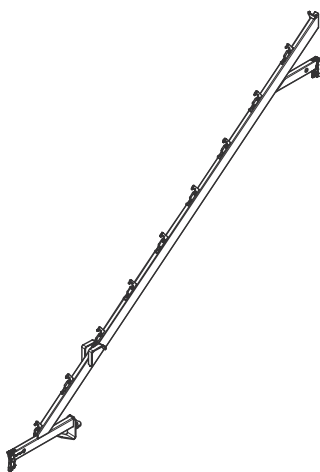

109198	7,390
114179	9,250

Stair Steps UAR

Stair Step UAR 100

Stair Step UAR 125

Tread for Stair Stringer UA. Non-slip due to perforated surface.

Technical Data

Permissible load 3.0 kN/m².

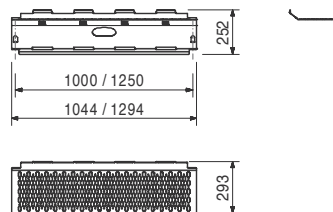
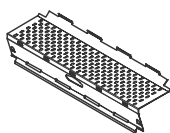

Item no.	Weight kg
109208	5,610
114180	6,590

End Steps UAE
End Step UAE 100
End Step UAE 125

Last step for the Stair Stringer UA. Secures all steps.

Technical Data
 Permissible load 3.0 kN/m².

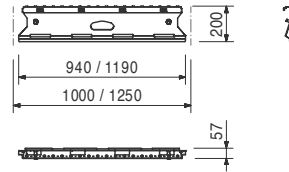
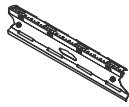

114349	0,770
114621	0,997

Edge Profiles UH
Edge Profile UH 100
Edge Profile UH 125

Assembly on UH Ledger for anti-slip protection on the first step at start of stairs with Stair Stringer UA.

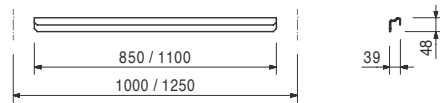
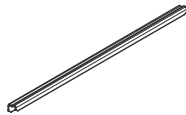

117191	3,490
--------	-------

Ladder Connection UAC

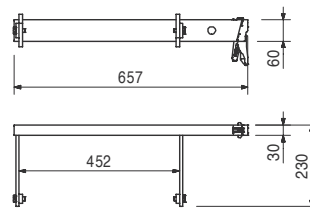
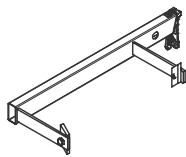

Item no.	Weight kg
113832	0,035

PERI UP Scaffold Tag Holder

To cordon off scaffolding areas not yet authorized for use. With the exception of inserting the PERI UP Assembly Certificate.



Item no.	Weight kg	Description
113833	0,005	PERI UP Assembly Certificates
113834	0,005	PERI UP Assembly Certificate, D
113829	0,005	PERI UP Assembly Certificate, EX
113835	0,005	PERI UP Assembly Certificate, F
113836	0,005	PERI UP Assembly Certificate, CDN
113837	0,005	PERI UP Assembly Certificate, ES
113838	0,005	PERI UP Assembly Certificate, PT
113838	0,005	PERI UP Assembly Certificate, PL
113839	0,005	PERI UP Assembly Certificate, CZ
115739	0,005	PERI UP Assembly Certificate, TR
115729	0,005	PERI UP Assembly Certificate, SK

Inserted into the PERI UP Scaffold Tag Holder.

Note

Front side:
Assembly report for release of scaffolding.
Rear side:
Test report

Inspection Record
Inspection by qualified person only

Important
Any modifications made to the scaffold, e.g. removal of anchors, may only be carried out by the scaffolder.

Date	Time	Signature

Scaffold is no longer authorized for use:
Date: _____

Assembly Certificate
To be completed by the supervisor

Installation location: _____
Position: _____
Client: _____
Scaffolder: _____
Date: _____
Signature: _____

Working scaffold according to EN 12811, for Load Class

W06
 W07

Width Class W

W06 0.6 < w < 0.9 m
 W08 0.9 < w < 1.2 m
 W10 1.2 < w < 1.5 m

Handing-Over Certificate
To be completed by the inspecting person

Name: _____
Signature: _____
Date, Time: _____
Remarks: _____

Item no.	Weight kg		
		Wall Ties UWT	L
100088	1,920	Wall Tie UWT 45	488
100091	4,680	Wall Tie UWT 110	1138
100093	5,870	Wall Tie UWT 140	1438
102951	7,060	Wall Tie UWT 170	1738
102954	9,050	Wall Tie UWT 220	2238
102957	11,000	Wall Tie UWT 270	2738

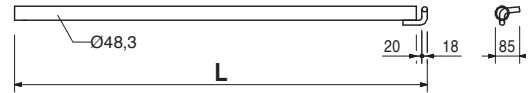
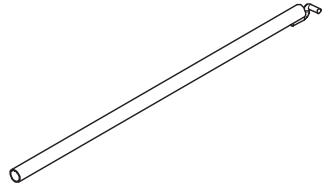

		Ring Bolts UFE	Safety Instructions
100693	0,169	Ring Bolt UFE 12/90	With marking for screw-in depth.
100694	0,190	Ring Bolt UFE 12/120	
100695	0,250	Ring Bolt UFE 12/190	

For assembling the Wall Tie UWT. Wall Inserts UFI 14 required.

		Wall Inserts UFI	
100696	0,007	Wall Insert UFI 14/70	
100697	0,009	Wall Insert UFI 14/100	
100698	0,010	Wall Insert UFI 14/135	

101858	7,000	Castor UEW 12 with Spigot	Technical Data
		Castor for mobile scaffolds. Wheel body red.	Permissible load 12 kN.

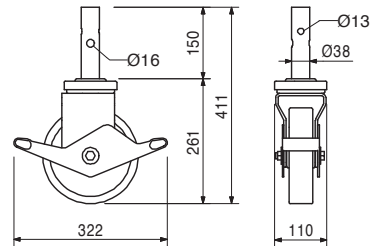
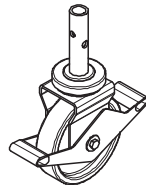

		Castor UEW 12 with Spindle	Technical Data
101860	7,500	Castor for mobile scaffolds. Wheel body red.	Permissible load 12 kN.

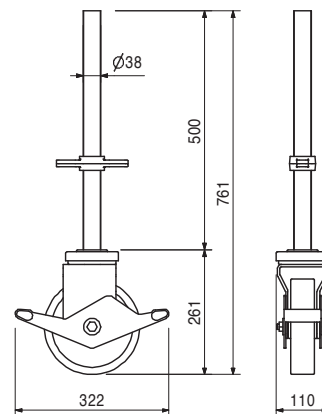
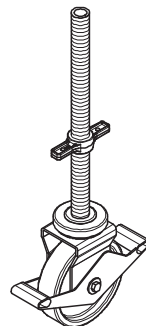

Item no.	Weight kg	
Debris Nets		
101347	1,800	Debris Net 2,5 x 10,0 m
101348	3,600	Debris Net 2,5 x 20,0 m
101349	2,160	Debris Net 3,0 x 10,0 m
101350	4,320	Debris Net 3,0 x 20,0 m

100871	0,002	Netting Tie Length 300 mm. Minimum bonding strength 23 KP.
--------	-------	--

Plastic Sheetings UT		
102021	13,500	Plastic Sheeting UT 2.70 x 20.0 m
102023	16,000	Plastic Sheeting UT 3.25 x 20.0 m

		L	X	Y
100428	8,040	1828	720/1040	2000
100416	9,740	2305	1500	2000
100419	11,000	2657	2000	2000
100422	12,400	3052	2500	2000
100425	13,900	3473	3000	2000

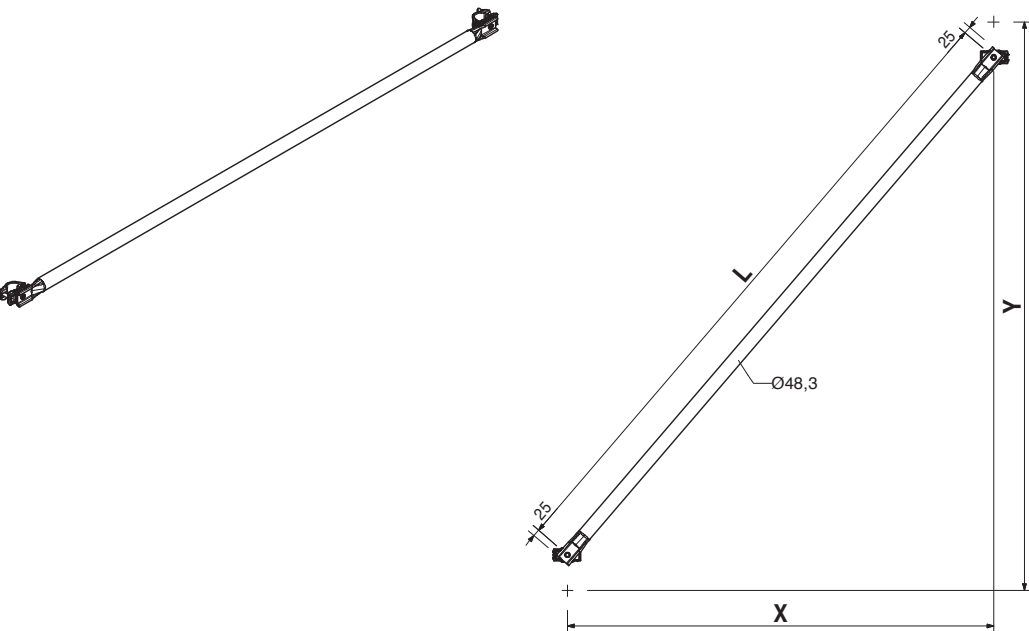

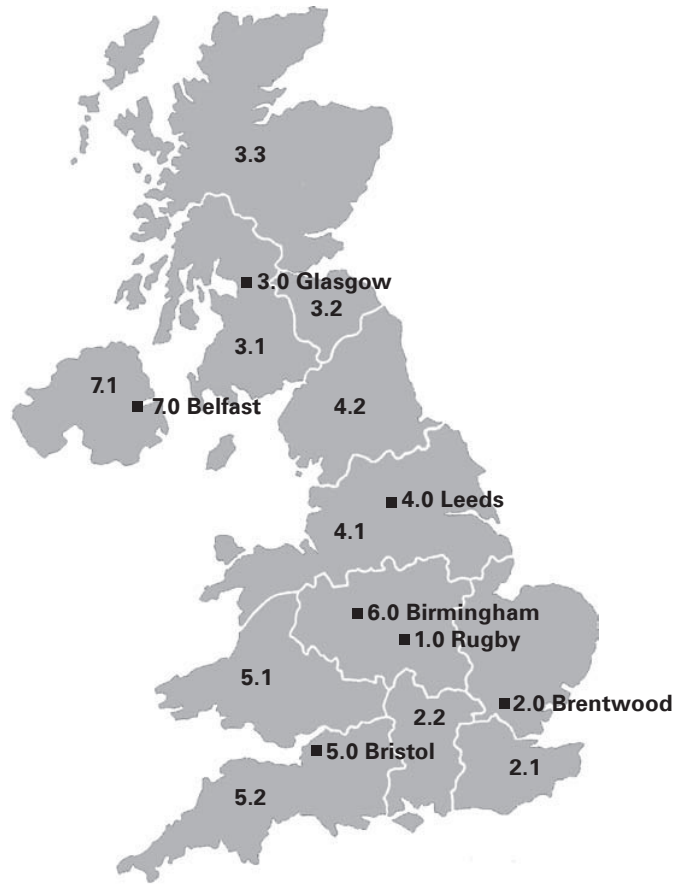

1.0 Rugby
Head Office

Market Harborough Road
 Clifton upon Dunsmore
 Rugby
 CV23 0AN

Tel: 01788 861600
 Fax: 01788 861610

2.0 Brentwood

Warley Street
 Great Warley
 Brentwood
 Essex
 CM13 3JZ

Tel: 01277 238820
 Fax: 01277 238860

3.0 Glasgow

331 Charles Street
 Glasgow
 G21 2QA

Tel: 0141 553 5252
 Fax: 0141 553 5253

4.0 Leeds

Unit E2
 Whitwood Enterprise Park
 Speedwell Road
 Whitwood, Castleford
 WF10 5PX

Tel: 01977 554361
 Fax: 01977 554389

5.0 Bristol

Bredon House
 Almondsbury Business Centre
 Woodlands, Bradley Stoke
 Bristol
 BS32 4QH

Tel: 01454 618117
 Fax: 01454 619593

6.0 Birmingham

Curdworth House
 Kingsbury Road
 Curdworth
 Sutton Coldfield
 B76 9EE

Tel: 01675 475509
 Fax: 01675 475167

7.0 Belfast

3 Weavers Court Business Park
 Linfield Road
 Belfast
 BT12 5GH

Tel: 02890 224028
 Fax: 02890 224010

PERI International



01 PERI GmbH

Rudolf-Diesel-Strasse
89264 Weissenhorn
info@peri.com
www.peri.com

02 France

PERI S.A.S.
77109 Meaux Cedex
peri.sas@peri.fr
www.peri.fr

03 Switzerland

PERI AG
8472 Ohringen
info@peri.ch
www.peri.ch

04 Spain

PERI S.A.
28110 Algete - Madrid
info@peri.es
www.peri.es

05 Belgium/Luxembourg

N.V. PERI S.A.
1840 Londerzeel
info@peri.be
www.peri.be

06 Netherlands

PERI B.V.
5480 AH-Schijndel
info@peri.nl
www.peri.nl

07 USA

PERI Formwork Systems, Inc.
Elkridge, MD 21075
info@peri-usa.com
www.peri-usa.com

08 Indonesia

PT Beton Perkasa Wijaksana
Jakarta 10210
bpw@betonperkasa.com
www.peri.com

09 Italy

PERI S.p.A.
20060 Basiano
info@peri.it
www.peri.it

10 Japan

PERI Japan K.K.
Tokyo 103-0015
info@perijapan.jp
www.perijapan.jp

11 United Kingdom/Ireland

PERI Ltd.
Rugby, CV23 0AN
info@peri.ltd.uk
www.peri.ltd.uk

12 Turkey

PERI Kalip ve İskeleleri
Esenyurt / İstanbul 34510
info@peri.com.tr
www.peri.com.tr

13 Hungary

PERI Kft.
1181 Budapest
info@peri.hu
www.peri.hu

14 Malaysia

PERI Formwork Malaysia
Sdn. Bhd.
43300 Seri Kembangan,
Selangor Darul Ehsan
info@perimalaysia.com
www.perimalaysia.com

15 Singapore

PERI ASIA Pte. Ltd
Singapore 387355
pha@periasia.com
www.periasia.com

16 Austria

PERI Ges.mbH
3134 Nußdorf ob der Traisen
office@peri.at
www.peri.at

17 Czech Republic

PERI spol. s r.o.
252 42 Jesenice u Prahy
info@peri.cz
www.peri.cz

18 Denmark

PERI Danmark A/S
2670 Greve
peri@peri.dk
www.peri.dk

19 Finland

PERI Suomi Ltd. Oy
05460 Hyvinkää
info@perisuomi.fi
www.perisuomi.fi

20 Norway

PERI Norge AS
3036 Drammen
info@peri.no
www.peri.no

21 Poland

PERI Polska Sp. z o.o.
05-860 Plochocin
info@peri.pl.pl
www.peri.pl.pl

22 Sweden

PERIform Sverige AB
30013 Halmstad
peri@periform.se
www.periform.se

23 Korea

PERI (Korea) Ltd.
Seoul 135-080
info@perikorea.com
www.perikorea.com

24 Portugal

PERIcofragens Lda
2790-326 Queijas
info@peri.pt
www.peri.pt

25 Argentina

PERI S.A.
B1625GPA Escobar - Bs. As.
info@peri.com.ar
www.peri.com.ar

26 Brazil

PERI Formas e
Escoramentos Ltda.
Vargem Grande Paulista
São Paulo
info@peribrasil.com.br
www.peribrasil.com.br

27 Chile

PERI Chile Ltda.
Colina, Santiago de Chile
peri.chile@peri.cl
www.peri.cl

28 Romania

PERI România SRL
077015 Balotești
info@peri.ro
www.peri.ro

29 Slovenia

PERI Slovenien
2000 Maribor
peri.slo@triera.net
www.peri.com

30 Slovakia

PERI spol. s r.o.
903 01 Senec
info@peri.sk
www.peri.sk

31 Australia

PERI Australia Pty. Ltd.
Glendenning NSW 2761
info@periaus.com.au
www.periaus.com.au

32 Estonia

PERI AS
76406 Saku vald
Harjumaa
peri@peri.ee
www.peri.ee

33 Greece

PERI Hellas Ltd.
194 00 Koropi
info@perihellas.gr
www.perihellas.gr

34 Latvia

PERI SIA
2118 Salaspils novads,
Rīgas rajons
info@peri-latvija.lv
www.peri-latvija.lv

35 United Arab Emirates

PERI (L.L.C.)
Dubai
perillc@perime.com
www.perime.com



36 Canada
PERI Formwork Systems, Inc.
Bolton, ON – L7E 1K1
info@peri.ca
www.peri.ca

37 Lebanon
Lebanon Representative Office
Jdeideh
lebanon@peri.de
www.peri.de

38 Lithuania
PERI UAB
02300 Vilnius
info@peri.lt
www.peri.lt

39 Morocco
PERI S.A.
Tanger
peri25@menara.ma
www.peri.com

40 Israel
PERI Formwork
Engineering Ltd
Petach Tikva, 49002
info@peri.co.il
www.peri.co.il

41 Bulgaria
PERI Bulgaria EOOD
1839 Sofia
peri.bulgaria@peri.bg
www.peri.bg

42 Iceland
Armar ehf.
220 Hafnarfjörður
www.armor.is

43 Kazakhstan
TOO PERI Kazakhstan
050014 Almaty
peri@peri.kz
www.peri.kz

44 Russian Federation
OOO PERI
142407, Noginsk District
moscow@peri.ru
www.peri.ru

45 South Africa
Wiehahn Formwork and
Scaffolding (Pty) Ltd.
7600 Stellenbosch
info@wiehahn.co.za
www.wiehahn.co.za

46 Ukraine
TOW PERI Ukraina
07400 Brovary
peri@peri.ua
www.peri.ua

47 Egypt
Egypt Branch Office
11361 Heliopolis / Cairo
info@peri.com.eg
www.peri.com.eg

48 Serbia
PERI Oplate d.o.o.
11272 Dobanovci
office@peri.rs
www.peri.rs

49 Mexico
PERI Cimbras y Andamios,
S.A. de C.V.
Estado de México,
info@peri.com.mx
www.peri.com.mx

50 Azerbaijan
PERI Kalip ve İşkeleleri
Baku
peribaku@peri.com.tr
www.peri.com.tr

51 Turkmenistan
PERI Kalip ve İşkeleleri
Aşgabat
ahmet.kadioglu@peri.com.tr
www.peri.com.tr

52 Belorussia
PERI Belarus
220030 Minsk
info@peri.by
www.peri.com

53 Croatia
PERI oplate i skele d.o.o.
10 250 Donji Stupnik/
Zagreb
info@peri.com.hr
www.peri.com.hr

54 Iran
PERI GmbH
Iran Branch Office
Tehran
info@peri.ir
www.peri.ir

55 India
PERI (India) Pvt Ltd
Mumbai – 400064
info@peri.in
www.peri.in

56 Jordan
PERI GmbH - Jordan
11947 Amman
jordan@peri.com
www.peri.com

57 Kuwait
PERI Kuwait
13011 Kuwait
kuwait@peri.com
www.peri.com

58 Saudi Arabia
PERI Engineering
Division of Jamjoom
Consult Saudi Arabia
21463 Jeddah
info@peri.com.sa
www.peri.com.sa

59 Qatar
PERI Qatar LLC
P.O.Box: 31295 - Doha
info@periqatar.com
www.periqatar.com

60 Algeria
Société PERI S.A.S.
Kouba - Alger
peri.alger@peri.fr
www.peri.fr

61 Albania
PERI Sh.p.k.
Tirane
erti.hasanaj@peri.com.tr
www.peri.com.tr

62 Peru
PERI Peruana SAC
Chorrillos, Lima
contacto@peri.com.pe
www.peri.com.pe

63 Panama
PERI Panama Inc.
0832-00155 Panama City
info@peri.com.pa
www.peri.com.pa

64 Angola
PERIcofragens, Lda.
Luanda
renato.portugal@peri.pt
www.peri.pt

65 Nigeria
Heights Access Nigeria Ltd.
Victoria Island, Lagos
info@heightsaccessng.com
www.heightsaccessng.com

66 Oman
PERI (L.L.C.)
Muscat
perimct@perime.com
www.perime.com

PERI Product Range



Wall Formwork

- Panel Formwork
- Girder Formwork
- Circular Formwork
- Facade Formwork
- Brace Frame



Climbing Systems

- Climbing Scaffold
- Self-Climbing System
- Climbing Protection Panel
- Platform Systems



Column Formwork

- Square
- Rectangular
- Circular



Scaffold, Stairways, Working Platforms

- Facade Scaffold
- Working Platform
- Weather Protection Roof
- Stairway Access



Slab Formwork

- Panel Formwork
- Beam Grid Formwork
- Girder Formwork
- Slab Table
- Beam Formwork

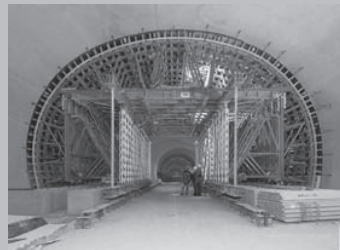

Bridge and Tunnel Formwork

- Cantilevered Parapet Carriage
- Cantilevered Parapet Platform
- Engineer's Construction Kit



Shoring Systems

- Steel Slab Props
- Aluminium Slab Props
- Tower Systems
- Heavy-duty Props

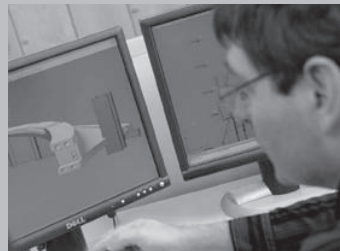

Services

- Formwork Assembly
- Cleaning / Repairs
- Formwork Planning
- Software
- Statistics
- Special Constructions

- Additional Systems
- Plywood
- Formwork Girders
- StoPend Systems
- Pallets
- Transportation Containers



PERI Ltd.

Formwork Scaffolding Engineering

Market Harborough Road
Clifton upon Dunsmore
Rugby, CV23 0AN

Tel: +44 (0) 1788 86 16 00

Fax: +44 (0) 1788 86 16 10

info@peri.ltd.uk

www.peri.ltd.uk