

Rail Climbing System RCS C

Climbing Formwork

Instructions for Assembly and Use – Standard Configuration – Issue 08 | 2019

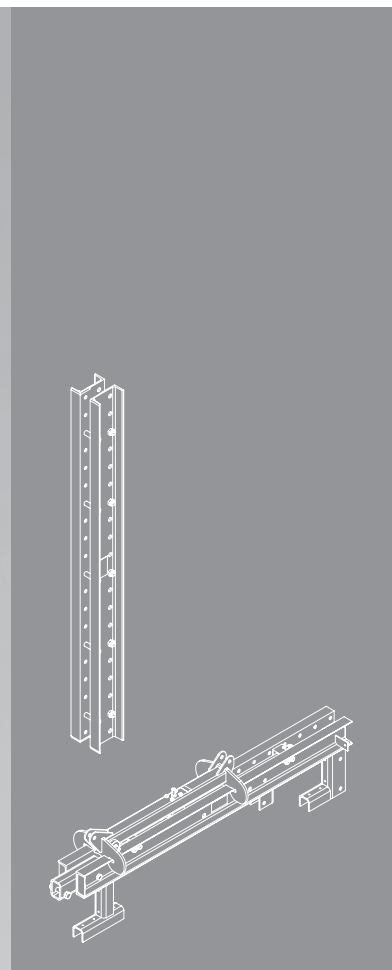
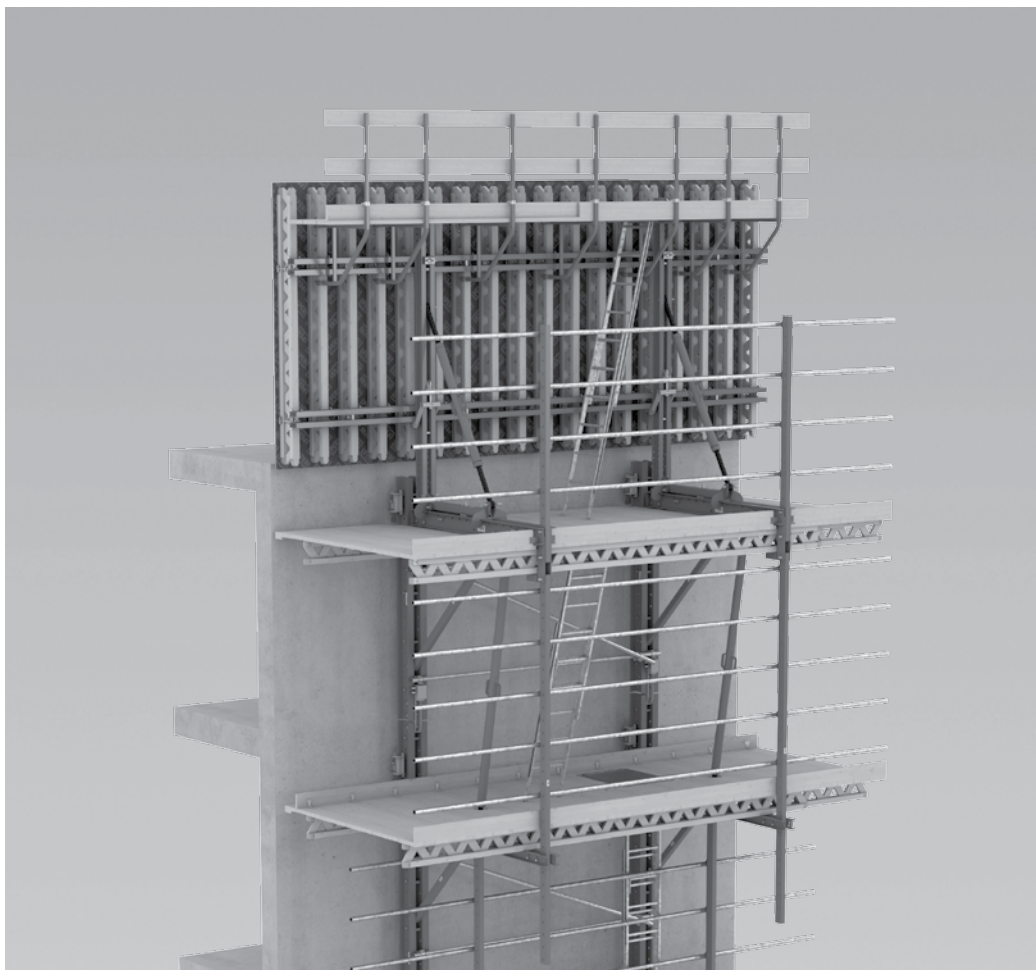

Main Components

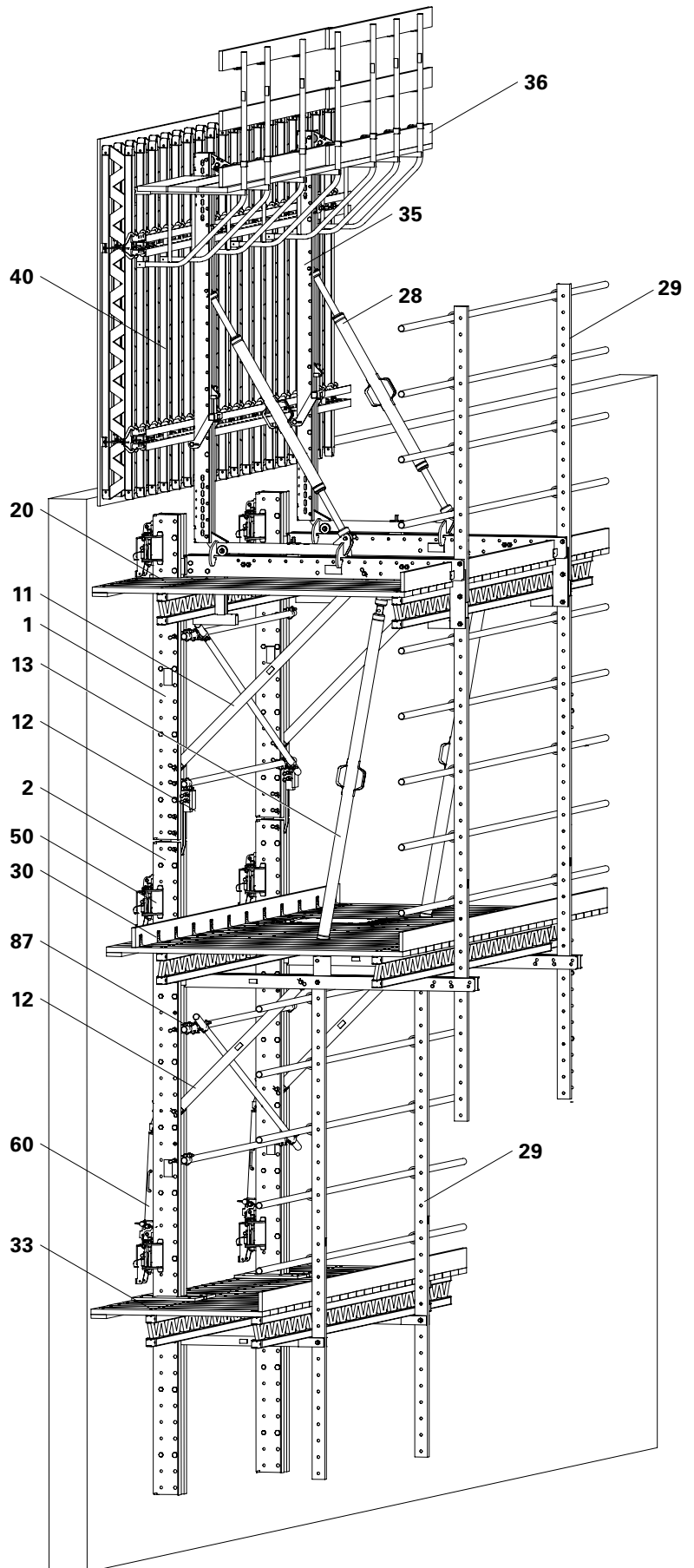

- 1 Top Climbing Rail
- 2 Bottom Climbing Rail
- 13 Framework Spindle
(Heavy-Duty Spindle SLS)
- 20 Working Platform
- 21 Crossbeam U160
- 24 Carriage RCS
- 28 Formwork Spindle
(Heavy-Duty Spindle SLS)
- 29 Rear Protection
- 30 Intermediate Platform
- 33 Finishing Platform
- 35 Strongback RCS/SRU
- 36 Concreting Platform
- 40 Formwork
- 50 Climbing Shoe RCS
- 60 Climbing Device RCS 50
- 87 Scaffold Tube Bracing

Overview			
Main Components	3		
Key	4		
Presentational Reference	4		
Introduction			
Target Groups	5		
Additional Technical Documentation	5		
Product Description	6		
Instructions on Use	6		
Cleaning and Maintenance Instructions	7		
Safety Instructions			
Cross-System	8		
System-Specific	10		
Maintenance and Repairs	11		
Climbing Procedure	12		
Storage and Transportation	12		
Component Overview and Tool List	14		
Tightening Torque	15		
General			
A1 System Overview	16		
A2 Climbing Device and Hydraulics	20		
General	20		
Climbing Device RCS 50	20		
Hydraulic Pump	21		
Accessories	22		
A3 Operating Status and Loads	24		
A4 Operating Sequence	26		
Concreting the Starter	26		
Concreting a Standard Section	28		
Work Preparation			
B1 Planning the Shoring	30		
System Dimensions	30		
Framework Assembly	31		
Additional Spacers	32		
Reaction Forces	33		
B2 Planning the Platforms	34		
General	34		
Platform Beams	35		
Scaffold Planks	38		
Toeboards	38		
Working Platforms	39		
Intermediate Platforms	40		
Finishing Platforms	41		
B3 Planning of Corner Platforms	42		
General	42		
Working Platforms	42		
Intermediate Platform	43		
Finishing Platform	44		
Concreting Platform	45		
B4 Planning of Rounded Platforms	46		
Bracket Arrangement: Parallel	46		
Bracket Arrangement: Radial	47		
B5 Planning of Guardrails	48		
Guardrails	48		
Lateral Guardrails	50		
Mounting the Handrail Boards	51		
Mounting the Scaffold Tubes	51		
B6 Planning Requirements	54		
Position of the Leading Anchor	54		
Planning the Climbing Sequence	55		
Attachment Point for the Crane	55		
Moving Procedure with the			
Climbing Traverse RCS 9 t	56		
Assembly			
C1 Pre-Assembling the Formwork	58		
Strongback on the TRIO Formwork	58		
Strongback with the Formwork			60
Waler 150 CB			62
Strongback on the VARIO Formwork			63
Concreting Platform			68
C2 Pre-Assembling the Bracket Unit	68		
Installation of the Working Platform	68		
Pre-Assembling the Climbing Rails	71		
C3 First Concreting Section	72		
Mounting the Climbing Rail	73		
Mounting the Working Platform	74		
Mounting the Formwork	75		
Mounting the Leading Anchor	76		
Concreting	78		
Initial Moving Procedure	79		
C4 Assembly of the Finishing Platform Unit	80		
General	80		
Pre-Assembling the Climbing Rails	80		
Pre-Assembling the Platforms	83		
Horizontal Assembly	84		
Vertical Assembly	90		
C5 Ladder Access	96		
Ladders	96		
Utilisation			
D1 Work Process in a Standard Cycle	98		
D2 Formwork Utilisation	102		
Operating the Carriage	102		
Adjusting the Formwork	103		
Adjusting the Lattice Framework	104		
D3 Leading Anchor	106		
Releasing the Leading Anchor	106		
D4 Suspension	108		
Assembly of the Suspension	108		
Dismantling the Suspension	109		
Removing the Climbing Cones	111		
D5 Operating the Climbing Shoe	112		
Opening and Closing the Climbing Shoe	112		
Activating / Deactivating the			
Climbing Pawl	114		
D6 Moving with the Crane	116		
Safety Instructions	116		
Preparations	117		
Moving Procedure	118		
If Climbed Too Far	119		
D7 Moving with the Climbing Device	120		
Safety Instructions	120		
Hydraulic Diagram	121		
Remedial Measures for Malfunctions	121		
Operating the Hydraulic System	121		
Bleeding the Hydraulic System	121		
Commencing Climbing Hydraulics			
Operations	122		
Preparations	122		
Moving Procedure	123		
Self-Climbing Procedure	124		
Finishing Tasks	130		
Self-Climbing Procedure of the Last Unit	131		
Dismantling			
E1 Lifting Out the Climbing Formwork	132		
General	132		
Dismantling the Formwork	132		
Lifting Out the Climbing Unit Separately	133		
Lifting Out the Complete Climbing Unit	135		
E2 Dismantling the Climbing Formwork	136		
Components			
RCS-C Rail Climbing Formwork			138

Key

Pictogram | Definition

 Danger / Warning / Caution

 Note

 To be complied with

 Load-bearing point

 Visual check

 Tip

 Misapplication

 Safety helmet

 Safety shoes

 Safety gloves

 Safety glasses

 Personal protective equipment to prevent falling from a height (PPE)

Arrows

 Arrow representing an action

 Arrow representing a reaction of an action*

 Forces

* If not identical to the action arrow.

Safety instruction categories

The safety instructions alert site personnel to the risks involved and provide information on how to avoid these risks. Safety instructions are featured at the beginning of the section or ahead of the instructions, and are highlighted as follows:

Danger

This sign indicates an extremely hazardous situation which, if not avoided, will result in death or serious injury.

Warning

This sign indicates a hazardous situation which, if not avoided, could result in death or serious injury.

Caution

This sign indicates a hazardous situation which, if not avoided, could result in minor or moderate injury.

Note

This sign indicates situations in which failure to observe the information can result in material damage.

Set-up of the safety instructions

Signal word

Type and source of the danger!
Consequences of non-compliance.
⇒ Avoidance measures

Dimension specifications

Dimensions are usually given in cm. Other measurement units, e.g. m, are shown in the illustrations.

Conventions

- Instructions are numbered with: 1., 2., 3.
- The result of an instruction is shown by: →
- Position numbers are clearly provided for the individual components and are given in the drawing, e.g. **1**, in the text in brackets, for example **(10)**.
- Multiple position numbers, i.e. alternative components, are represented with a slash, e.g. **1/2**.

Presentational reference

The illustration on the front cover of these instructions is understood to be a system representation only. The assembly steps presented in these Instructions for Assembly and Use are shown in the form of examples with only one component size. They are valid accordingly for all component sizes contained in the standard configuration.

For a better understanding, detailed illustrations are partly incomplete. Some safety installations which have possibly not been shown in these detailed descriptions must nevertheless still be available.

Target Groups

Contractors

These Instructions for Assembly and Use are designed for contractors who either

- assemble, modify and dismantle the formwork system, or
- use it, e.g. for concreting, or
- allow it to be used for other operations, e.g. carpentry or electrical work.

Competent person

(Construction Site Coordinator)

The Safety and Health Protection Coordinator*

- is appointed by the client,
- must identify potential hazards during the planning phase,
- determines measures that provide protection against risks,
- creates a health and safety plan,
- coordinates the protective measures for the contractor and site personnel so that they do not endanger each other,
- monitors compliance with the protective measures.

Competent person qualified to carry out inspections

Due to the specialist knowledge gained from professional training, work experience and recent professional activity, the competent person qualified to carry out inspections has a reliable understanding of safety-related issues and can carry out inspections correctly. Depending on the complexity of the inspection to be undertaken, e.g. scope of testing, type of testing or the use of certain measuring devices, a range of specialist knowledge is necessary.

Qualified personnel

Formwork systems may only be assembled, modified or dismantled by personnel who are suitably qualified to do so. For the work to be carried out, the qualified personnel must have received instructions** covering at least the following points:

- Explanation of the plan for the assembly, modification or dismantling of the formwork in an understandable form and language.
- Description of the measures for assembling, modifying or dismantling the formwork.

- Naming of the preventive measures to be taken to avoid the risk of persons and objects falling.
- Naming of the safety precautions in the event of changing weather conditions which could adversely affect the safety of the formwork system as well as the persons concerned.
- Details regarding permissible loads.
- Description of all other risks and dangers associated with assembly, modification or dismantling operations.



- **In other countries, ensure that the relevant national guidelines and regulations in the respective current version are complied with!**
- **If no country-specific regulations are available, it is recommended to proceed according to German guidelines and regulations.**
- **A competent person must be present on site during formwork operations.**

* Valid in Germany: Regulations for Occupational Health and Safety on Construction Sites 30 (RAB 30).

** Instructions are given by the contractor himself or a competent person selected by him.

Additional Technical Documentation

- Instructions for use:
 - Lifting Beam 9 t
- Assembly instructions:
 - RCS Climbing Device and Hydraulics
- Product approvals:
 - Z-21.6-1766 PERI Screw-On Cone
 - Z-21.6-1767 PERI Climbing Cone
- Separate design information
- Design Tables 2015 – Formwork and Shoring

Product Description

Standard assembly

These Instructions for Assembly and Use describe the standard assembly of the Rail Climbing System RCS as formwork scaffold.

- with intermediate and finishing platforms,
- with one Climbing Shoe per concreting section
- self-climbing or rail-guided with the help of a crane,
- with Climbing Device RCS 50 which is installed from the intermediate platform.

Features

The RCS Formwork Scaffolding is a standard application of the RCS Rail Climbing System.

The system is a bracket-type framework construction and has been designed as falsework for supporting wall formwork according to DIN EN 12812 (formerly DIN 4421).

The climbing scaffold consists of 2 bracket structures (Climbing Rails with Platform Beams and Struts) which are connected to the platforms (working platform, intermediate platform and finishing platform) and scaffold tube bracing. The platforms consist of planking installed on platform beams. The platforms are pre-assembled on crossbeams (working platform), intermediate platform beams and/or finishing platform beams.

By connecting the formwork and climbing scaffold by means of strongbacks, this results in climbing formwork which is moved as a climbing unit with the crane or using a hydraulic climbing device.

The vertical spacings of the platforms to each other can be realised using 12.5-cm increments.

RCS Formwork Scaffolding can also be equipped with an enclosure. Project-specific planning is required here.

Intended use

- Use as formwork scaffolding in building construction projects
- Realisation of in-situ walls
- Provides anti-fall protection for site personnel
- Protection against falling objects
- Protection against the effects of the weather (only with an enclosure)

PERI products have been designed for exclusive use in the industrial and commercial sectors by qualified personnel only.

Instructions on Use

Use in a way not intended according to the Instructions for Assembly and Use, or any use deviating from the standard configuration or the intended use, represents a misapplication with a potential safety risk, e.g. risk of falling.

Only PERI original parts may be used. The use of other products and spare parts is not allowed.

Changes to PERI components are not permitted.

The system described in these Instructions for Assembly and Use may contain patent-protected components.

Cleaning and Maintenance Instructions

In order to maintain the value and operational readiness of the climbing formwork over the long term, clean the surface areas after every use.

The following points should help to keep cleaning and maintenance costs as low as possible.

For cleaning and maintenance of the hydraulic system, observe the Instructions for Use for the RCS Climbing Device and Hydraulics.

Spray the formwork on both sides with concrete release agent before each use; this facilitates easier and faster cleaning of the formwork. Spray the concrete release agent very thinly and evenly!

Do not spray working platforms or access ways with a concrete release agent – slipping hazard!

Spray the rear side of the formwork with water immediately after concreting; this avoids any time-consuming and costly cleaning operations.

When used continuously, spray the panel formlining with concrete release agent immediately after striking; then clean by means of a scraper, brush or rubber lip scraper. Important: do not clean formlining made of plywood with high-pressure equipment. This could result in the formlining being damaged.

Fix box-outs and mounting parts with double-headed nails; as a result, the nails can easily be removed later, and damage to the formlining is largely avoided.

Close all unused anchor holes with plugs; this eliminates any subsequent cleaning or repair work. Anchor holes accidentally blocked with concrete are cleared by means of a steel pin from the formlining side.

When placing bundles of reinforcement bars or other heavy objects on horizontally stored formwork elements, suitable support, e.g. square timbers, is to be used: this largely avoids impressions and damage to the formlining.

Internal concrete vibrators should be fitted with rubber caps if possible; as a result, any damage to the formlining is reduced if the vibrator is accidentally inserted between the reinforcement and formlining.

Never clean powder-coated components, e.g. elements and accessories, with a steel brush or hard metal scraper: this ensures that the powder coating remains intact.

Use spacers for reinforcement with large-sized supports or extensive areas of support; this largely avoids impressions being formed in the formlining when under load.

Mechanical components, e.g. climbing rails in the glide area of the climbing shoes, spindles or gear mechanisms, should be cleaned before and after use, thus removing dirt or concrete residue and subsequently greased with a suitable lubricant.

Provide suitable support for the components during cleaning so that no unintentional change in their position is possible.

Do not clean components suspended on crane lifting gear.

Cross-System



The safety instructions apply to all phases of the system.

General

The contractor must ensure that the Instructions for Assembly and Use supplied by PERI are available at all times and understood by the site personnel.

These Instructions for Assembly and Use can be used as the basis for creating a risk assessment. The risk assessment is compiled by the contractor. However, these Instructions for Assembly and Use do not replace the risk assessment!

Always take into consideration and comply with the safety instructions and permissible loads.

For the application and inspection of PERI products, the current safety regulations and guidelines valid in the respective countries must be observed.

Materials and working areas are to be inspected before each use and assembly for:

- signs of damage,
- stability and
- function.

Damaged components must be exchanged immediately on site and may no longer be used.

Safety components are to be removed only when they are no longer required.

Components provided by the contractor must conform to the characteristics required in these Instructions for Assembly and Use, as well as all valid construction guidelines and standards. Unless otherwise indicated, this applies in particular to:

- timber components:
Strength Class C24 for Solid Wood according to EN 338.
- scaffold tubes:
galvanised steel tubes with minimum dimensions of $\varnothing 48.3 \times 3.2$ mm according to EN 12811-1:2003 4.2.1.2.
- scaffold tube couplers according to EN 74.

Deviations from the standard configuration are only permitted after a further risk assessment has been carried out by the contractor.

Appropriate measures for working and operational safety, as well as stability, are defined on the basis of this risk assessment.

Corresponding proof of stability can be provided by PERI on request if the risk assessment and resulting measures to be implemented are made available.

Before and after exceptional occurrences that may have an adverse effect on the safety of the formwork system, the contractor must immediately

- create another risk assessment, with appropriate measures being carried out based on the results, to ensure the stability of the formwork system,
- arrange for an extraordinary inspection to be carried out by a competent person qualified to do so. The aim of this inspection is to identify and rectify any damage in good time in order to guarantee safe use of the formwork system.

Exceptional occurrences can include:

- accidents,
- longer periods of non-use,
- natural events, e.g. heavy rainfall, icing, heavy snowfall, storms or earthquakes.

Assembly, modification and dismantling work

Assembly, modification or dismantling of the climbing system may only be carried out by qualified persons and under the supervision of a competent person. The qualified personnel must have received appropriate training for the work to be carried out with regard to specific risks and dangers.

On the basis of the risk assessment and Instructions for Assembly and Use, the contractor must create installation instructions in order to ensure safe assembly, modification and dismantling of the climbing unit.

The contractor must ensure that the personal protective equipment required for the assembly, modification or dismantling of the climbing formwork, e.g.

- safety helmet,
- safety shoes,
- safety gloves,
- safety glasses,

is available and used as intended.

If personal protective equipment against falling from a height (PPE) is required or specified in local regulations, the contractor must determine appropriate attachment points on the basis of the risk assessment.

The contractor stipulates the PPE to be used to prevent falling.

The contractor must

- provide safe working areas for site personnel, which are to be reached through the provision of safe access ways. Areas of risk must be cordoned off and clearly marked.
- ensure stability during all stages of construction, in particular during assembly, modification and dismantling operations.
- ensure and prove that all loads can be safely transferred.

Utilisation

Every contractor who uses or allows the climbing system to be used is responsible for ensuring that the equipment is in good condition.

If the climbing system is used successively or at the same time by several contractors, the health and safety coordinator must point out any possible mutual hazards, and all work must then be coordinated.

System-Specific



The safety instructions apply to all phases of the system.

Assembly work

The contractor must ensure that the user has the appropriate and sufficient number of tools, approved and inspected lifting equipment and slings, suitable and sufficient space for assembly and storage, as well as adequate crane capacity at his disposal.

There is always the possibility of unforeseen risks arising during assembly work. The level of risk is to be estimated according to each individual case and, if necessary, measures are to be taken to avoid or at least to minimise the risk.

If anti-fall protection cannot be used or has to be removed due to operational reasons, safety equipment must be installed in its place in order to prevent or arrest falls from any height.

If the use of fall arrest equipment is deemed to be inappropriate, personal protection equipment (PPE) can be used if suitable fixing points are available.

Do not remain under any suspended loads. If work under suspended loads cannot be avoided, determine and apply all appropriate safety measures. Avoid entering the area between an approaching and a fixed component.

Use a guide rope to ensure that assembly units suspended from the crane are fully under control when being moved.

Site personnel are forbidden to remain in areas below where assembly work is being carried out, unless the area of risk has been provided with sufficient protection against falling, overturned, sliding or rolling objects and masses. The area of risk is to be cordoned off.

Access means

Safe access to all working areas must be guaranteed at all times. Preferred options are walkways, stairs, stair towers or site lifts. When working at great heights, use erection scaffold.

Internal scaffold ladders can connect max. 2 scaffold levels to one another. Internal scaffold ladders are to have an offset arrangement. They must be secured on the outer side of the scaffold by means of appropriate anti-fall equipment such as rear safety protection or safety nets.

Suitable equipment must be available on hatches and openings of the climbing formwork in order to prevent accidents. After the ladder access is used each time, ensure that the hatch cover is closed.

In the case of an emergency situation, the working areas must have escape routes in place or suitable rescue equipment available. It must also be ensured that at least one emergency escape route or piece of rescue equipment can still be used if the power supply fails.

The access areas on the construction site must be free of obstacles and tripping hazards, as well as being slip-resistant.

Do not walk on components; use a secure and sufficiently load-bearing position next to the components.

BGI 663

“Handling instructions for the use of work and safety scaffolding.”

Extract taken from Section 7:

- For their own safety, it is important that site personnel use the designated access means for ascents and descents, and do not climb or jump off the scaffolding.
- Do not jump on the scaffold decking nor throw any objects off the side.

Protection against falling objects

Avoid positioning working areas and access points in areas of risk. If this is not possible due to work procedures, suitable protection equipment must be available. This also applies to work requiring only a short period of time.

Secure tools and materials to prevent them from falling to the ground.

Remove concrete residue and other dirt as soon as possible, at the latest before the next climbing cycle.

In general, the platforms are to be kept clean at all times.

Operational working areas at great heights are to be secured against falling objects by means of appropriate constructional measures.

Component stability

Secure those components whose stability may be at risk using suitable means, e.g. with push-pull props, or attach to the crane lifting gear until the risk of tipping has been eliminated. Site personnel must remain clear of the area of risk from tipping. Indicate areas of risk and ensure that these areas are clearly marked.

If necessary, cordon off the area of risk using suitable means. Check before work operations begin in each case whether safety signs and barriers are in position.

Maintenance and repairs

The system components are to be inspected before each use to ensure that they are in perfect condition and functioning correctly. Only materials in perfect condition are to be used.

The platforms are to be inspected for signs of damage by authorised personnel on a monthly basis. Dirt which affects functionality is to be removed immediately. Damaged components are to be inspected, removed and replaced.

If the maximum permissible wind speed has been exceeded, temperatures are outside the scope of application, or after any extraordinary event has taken place such as a fire or earthquake, the functionality and load-bearing capacity of all safety components, as well as the supporting structure, are to be checked.

Disconnect the system from the power supply before starting an inspection and secure it against being switched on again.

Safety components:

- A visual inspection is to be carried out by authorised personnel before each climbing operation.
- Before any climbing or assembly, a functionality check is carried out by qualified personnel.
- If parts need to be replaced, only PERI original components may be used.
- Repairs are carried out by qualified PERI personnel only.
- In the case of overloading or recurrent damage, stop work operations on and under the platforms, determine the cause and then rectify.

Supporting structure:

- A visual inspection is to be carried out by authorised personnel before initial use.
- Only PERI original components are to be used for repairs or replacement.
- In the case of overloading or recurrent damage, stop work operations on and under the platforms, determine the cause and then rectify.

Other components:

- Repairs are carried out by authorised personnel and the contractor/site management is to be informed.
- Determine the cause of any damage that occurs repeatedly and then rectify.

Climbing procedure

The climbing formwork cannot be mounted for the next concreting step until the required concrete strength has been achieved.

As a result of the moving procedure, unprotected leading edges are formed. These areas are to be cordoned off. Additional equipment must be in place in order to secure those persons working at the leading edge, e.g. personal protective equipment against falling from a height (PPE).

Site personnel, construction materials or tools may not be transported with the crane during moving operations. Exceptions to this can be determined through the operational working and assembly instructions on the basis of a corresponding risk assessment.

The climbing procedure must be monitored by a competent and qualified person.

During the climbing procedure, clamping and crushing hazards are present that are caused by moving components.

Those persons carrying out the climbing procedure must be fully informed about all possible hazards.

All persons who are not required to carry out the climbing procedure must leave the area of risk.

When climbing with the hydraulic climbing device, specifications regarding the arrangement of the hydraulic hoses are to be observed. If the standard arrangement is not possible, an authorised person must determine a safe and secure alternative.

In case of a malfunction, personnel must lower the platform to the next possible position and then leave the climbing unit in a safe and secure manner and inform an authorised person immediately.

Storage and transportation

Store and transport components ensuring that no unintentional change in their position is possible. Detach lifting accessories and slings from the lowered components only if they are in a stable position and no unintentional change is possible.

Do not drop the components.

Use PERI lifting accessories and slings and only those load-bearing points provided on the component.

During the moving procedure

- ensure that components are picked up and set down so that unintentional falling over, falling apart, sliding, falling down or rolling is avoided.
- no persons are allowed to remain under the suspended load.

The access areas on the construction site must be free of obstacles and tripping hazards, as well as being slip-resistant.

For transportation, the surface used must have sufficient load-bearing capacity.

Use original PERI storage and transport systems, e.g. Crate Pallets, Pallets or Stacking Devices.

Component Overview and Tool List



Pos. no.	Component name	Item no.
1	Top Climbing Rail RCS	
1.1	Climbing Rail RCS 248	109469
1.2	Climbing Rail RCS 348	109470
2	Bottom Climbing Rail RCS	
2.1	Climbing Rail RCS 498	109471
2.2	Climbing Rail RCS 748	109472
3	Spacer M20-82	110022
4	Spacer M24-82	110023
6	Climbing Rail Extension RCS 100	109791
8	Climbing Rail Hinge RCS	110569
9	Crane Eye BR-2 2.5 t	127834
10	Lifting Beam RCS 9 t	112986
11	Diagonal Strut l = 2121	110012
12	Diagonal Strut l = 1416	109718
13	Heavy-Duty Spindle SLS 260/360	101779
15	Fitting Pin Ø 21 x 120	104031
16	Cotter Pin 4/1	018060
20	Working Platform	
21	Crossbeam Unit RCS 220 VARIO	118094
22	Crossbeam Head RCS/VARIO	110015
24	Carriage RCS	109968
25	Steel Waler Universal SRU L = 2.72	103929
26	Waler Fixation U100 - U120	110059
27	Adjusting Unit SRU, external	110400
28	Heavy-Duty Spindle SLS 200/300	101778
29	Ladder Safety Cage	
30	Intermediate Platform	
31	Intermediate Platform Beam	109717
32	Waling	
33	Finishing Platform	
34	Finishing Platform Beam	109722
35	Strongback Adapter RCS/SRU	115325
36	Concreting Platform	
37	Platform Beam RCS/SRU 113	114301
39	Formwork Intermediate Platform	
40	Formwork VARIO	
41	TRIO Panel	
42	Leading Anchor	
42.1	Advancing Bolt M30	029450
42.2	Anchor Positioning Stud M30	026450
42.3	Anchor Positioning Plate M30	029380
47	Anchoring	
47.1	Screw-On Cone M30/DW 26	057257
47.2	Threaded Anchor Plate DW 20	030860
47.3	Anchor Sleeve M24	026230

Pos. no.	Component name	Item no.
47.4	Cone for Anchor Sleeve	
47.5	Climbing Cone-2 M30/DW 20	031220
47.6	Tie Rod DW 20, Special Length	030700
47.7	Threaded Anchor Plate DW 26	030870
47.8	Spacer Tube Ø 22	
47.9	Cone DR 22	065033
49	Bolt ISO 4017 M30 x 70-8.8	029420
50	Climbing Shoe RCS	109468
51	Wall Shoe RCS	109503
53	Wall Shoe RCS, hinged	110667
54	Excentric Lever RCS	110950
60	Climbing Device RCS 50	109765
61	Hydraulic Twin Hoses RCS 10 m	110069
62	Hydraulic Twin Hoses RCS 20 m	110070
63	Hydraulic Pump RCS 4 x 190 bar	109766
64	Adapter Cable RCS	110280
65	Plug Socket RCS, black	110279
66	Hatch 55 x 60-2, foldable	110608
67	Ladder 180/6	051410
68	Ladder 220/6	051420
69	End Ladder 180/2	812938
70	Ladder Base 30, adjustable	109105
71	Ladder Hook	103718
72	Ladder Safety Cage 75	104132
73	Ladder Safety Cage 150	051450
75	Lattice Girder GT 24 e.g. 450	075450
76	Planking	
77	Toeboard	
78	Angle Bracket 90°	123478
79	Guardrail Post RCS 226	109720
80	Guardrail Post RCS/SRU 184	114328
81	Guardrail Post 384 RCS	109721
82	Guardrail Boards	
84	L-angle	110289
85	Enclosure Beam (timber)	
86	Enclosure (multi-layer plywood sheeting)	
87	Scaffold Tube Bracing	
88	Steel Scaffold Tube Ø 48.3 x 3.2	026413
89	Clamp A64 DIN 3570	110296
91	Scaffold Tube Connector LPS/RCS D = 48	125856
92	End Guardrail Post CB	051610
93	Guardrail Connector CB	051160
94	Guardrail Post Holder Multi	126088
95	Standard Coupler RA 48/48	017020
96	Half-Coupler-2 W. Bolt HT B D48-M20	131404

Pos. no.	Component name	Item no.
97	Swivel Coupler SW 48/48	017010
98	Timber 6/6	
99	Deck Covering	
101	Bolt ISO 4017 M12 x 40-8.8	710224
102	Bolt ISO 4017 M12 x 140-8.8	110598
106	Bolt ISO 4014 M20 x 120-8.8	104477
107	Bolt ISO 4014 M20 x 150-8.8	711084
108	Bolt ISO 4014 M24 x 130-8.8	109612
110	F.H. Bolt DIN 603 M8 x 100 MU	710240
111	F.H. Bolt DIN 603 M8 x 70 MU	024140
112	F.H. Bolt DIN 603 M8 x 200 MU	024390
113	F.H. Bolt DIN 603 M8 x 250 MU	024410
114	F.H. Bolt DIN 603 M8 x 125 MU	024360
115	Nut ISO 7040 M20-8	781053
116	Nut ISO 7040 M24-8	105032
118	Nut ISO 7040 M12-8	710381
120	Washer ISO 7093 200 HV, A8	710342
121	Washer ISO 7089 200 HV, A8	780354
122	Washer ISO 7094 12-100 HV	113348
125	TSS-Torx 6 x 80	024690
126	TSS-Torx 6 x 60	024470
127	TSS-Torx 6 x 40	024540
129	Spax Screw TX25, 5 x 20	111437
132	Spax Screw TX30, 6 x 100	024950
135	Hex. Wood Screw 6 x 20 DIN 571	029440
136	Hex. Wood Screw 6 x 80 DIN 571	051640
137	Hex. Wood Screw 8 x 60 DIN 571	024270
138	Hex. Wood Screw 8 x 80 DIN 571	324260
139	Wingnut Pivot Plate DW 15	030370
140	Formwork Waler 150 CB	127633
141	Hook Tie DW 15/400	023650
142	Clamp Adapter MX / TR-SRU	127659
143	Wire Nail 3 x 80	710312
144	Tension Belt L = 5.7 m, 2.5 t	051250

Tool name
Cordless Screwdriver
Screw Bits Torx 25/30/35
Ring Wrench, Open-End Wrench, Socket Wrench SW 13/17/19/30/36/46
Wood Drill Ø 5/8/9/13/22
Allen Key 14
Torque Wrench
Hammer
Round Slings
4-Sling Lifting Gear
PERI Hydraulics Case

Abbreviations used in these Instructions for Assembly and Use:

a	anchor spacing for concrete joints
b_n	width nth designated section
C	Climbing Rail spacing
d_n	thickness nth designated section
G	weight force
V	vertical force
V_{AY}	anchor shear force
N_A	anchor tension force
H	height
h_n	height nth designated section
h_B	storey height
H_x	horizontal force
L	length
L_n	length nth designated section
q	wind load
v	speed
W	wind pressure

Tightening Torque

For non-defined lubricated screw connections, PERI recommends the following guide values as "hand-tightened" tightening torque MA. These guide values are based on EN 15048 with Safety Factor 3 against breakage of a bolt with Strength Class 4.6.

Bolt M8	8 Nm
Bolt M10	16 Nm
Bolt M12	30 Nm
Bolt M16	65 Nm
Bolt M20	100 Nm
Bolt M24	150 Nm
Bolt M30	260 Nm
Bolt M36	350 Nm

Tightening torque has been determined for the following components:

Bolt of Spacer M20	100 Nm
Bolt of Spacer M24	150 Nm
Scaffold coupling	50 Nm

Climbing Unit

The assembly of the climbing scaffold varies depending on the storey height along with type of formwork and anti-fall protection used.

In all versions, the Climbing Rails (2) are supported by Climbing Shoes (50) and Wall Shoes (51) which are mounted on pre-completed building parts. As a general rule, the Climbing Rails are divided.

The Crossbeams for the working platform with Carriage and Strongbacks for the formwork system are mounted on the Climbing Rails (1). Intermediate and finishing platforms are mounted on additional platform beams.

Side protection can be realised in the form of a closed enclosure, scaffolding tubes or handrail boards.



All of the following versions are execution examples.

Version 1:

Use with VARIO formwork and scaffolding tubes as guardrails
Storey height (h_B) = 2.70 m.
(Fig. A1.01)

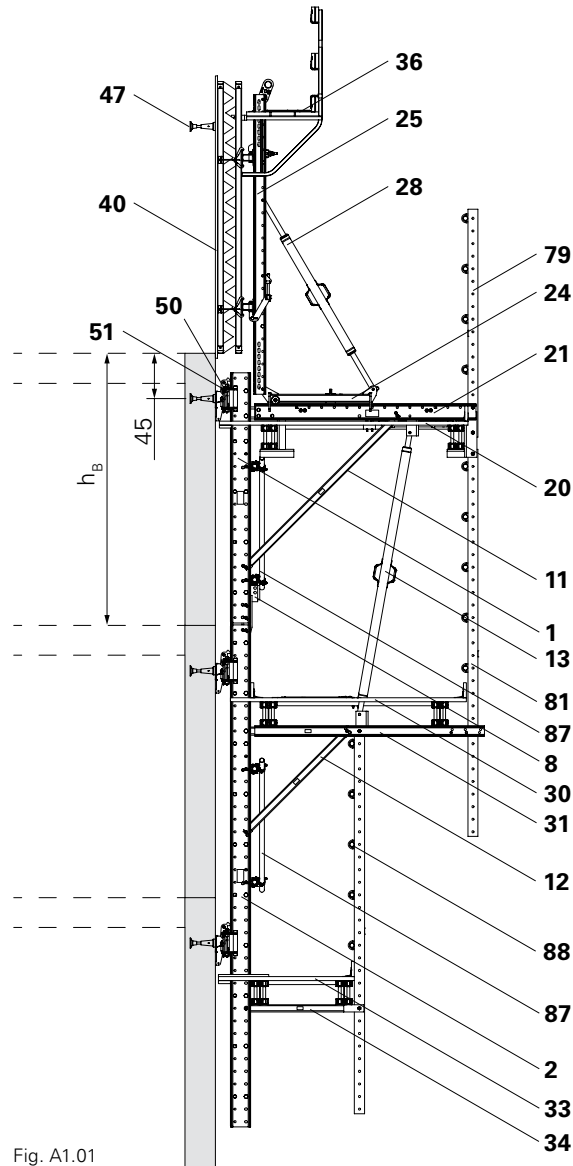

Fig. A1.01

Version 2:

Use with TRIO formwork and scaffold tubes as guardrails.

$h_B = 3.20$ m.
(Fig. A1.02)

Components

- 1 Top Climbing Rail RCS
- 2 Bottom Climbing Rail RCS
- 8 Climbing Rail Hinge RCS
- 11 Diagonal Strut I = 2121
- 12 Diagonal Strut I = 1416
- 13 Framework Spindle (Heavy-Duty Spindle e.g. SLS260/360)
- 20 Working Platform
- 21 Crossbeam Unit RCS 220 VARIO
- 24 Carriage RCS
- 25 Strongback RCS (Steel Waler Universal SRU L = 2.72)
- 28 Formwork Spindle (Heavy-Duty Spindle e.g. SLS 200/300)
- 30 Intermediate Platform
- 31 Intermediate Platform Beam
- 33 Finishing Platform
- 34 Finishing Platform Beam
- 35 Strongback Adapter RCS/SRU
- 36 Concreting Platform
- 40 Formwork VARIO
- 41 Formwork TRIO
- 47 Anchoring for the next section
- 50 Climbing Shoe RCS
- 51 Wall Shoe RCS
- 79 Guardrail Post U100 225 RCS
- 81 Guardrail Post U100 384 RCS
- 87 Scaffold Tube Bracing
- 88 Steel Scaffold Tube $\varnothing 48.3 \times 3.2$

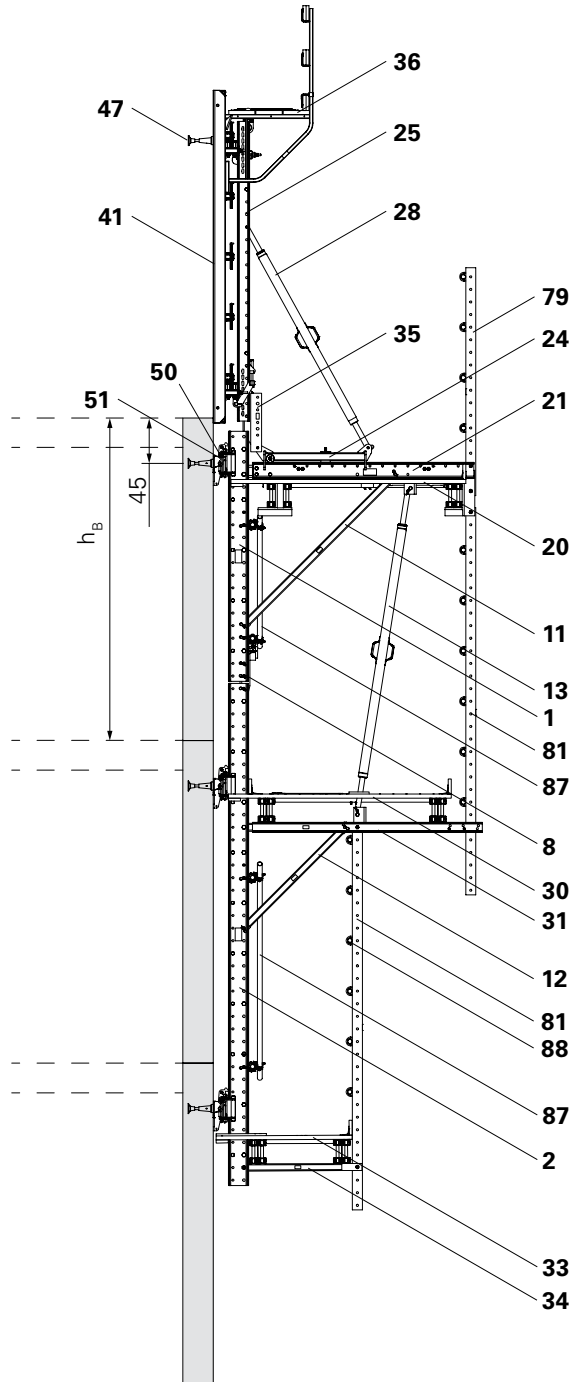

Fig. A1.02

Version 3:

Use with VARIO formwork and timbers with enclosure.

$h_B = 3.50$ m.

(Fig. A1.03)

Components

- | | |
|-----------|--|
| 1 | Top Climbing Rail RCS |
| 2 | Bottom Climbing Rail RCS |
| 6 | Climbing Rails Extension RCS 100 |
| 8 | Climbing Rail Hinge RCS |
| 11 | Diagonal Strut I = 2121 |
| 12 | Diagonal Strut I = 1416 |
| 13 | Framework Spindle (Heavy-Duty Spindle e.g. SLS260/360) |
| 20 | Working Platform |
| 21 | Crossbeam Unit RCS 220 VARIO |
| 24 | Carriage RCS |
| 25 | Strongback RCS (Steel Waler Universal SRU) |
| 28 | Formwork Spindle (Heavy-Duty Spindle e.g. SLS 200/300) |
| 30 | Intermediate Platform |
| 31 | Intermediate Platform Beam |
| 33 | Finishing Platform |
| 34 | Finishing Platform Beam |
| 36 | Concreting Platform |
| 39 | Formwork Intermediate Platform |
| 40 | Formwork VARIO |
| 47 | Anchoring |
| 50 | Climbing Shoe RCS |
| 51 | Wall Shoe RCS |
| 79 | Guardrail Post U100 225 RCS |
| 81 | Guardrail Post U100 384 RCS |
| 82 | Guardrail Boards |
| 85 | Enclosure Beam (timber) |
| 86 | Enclosure (multi-layer plywood sheeting) |
| 87 | Scaffold Tube Bracing |

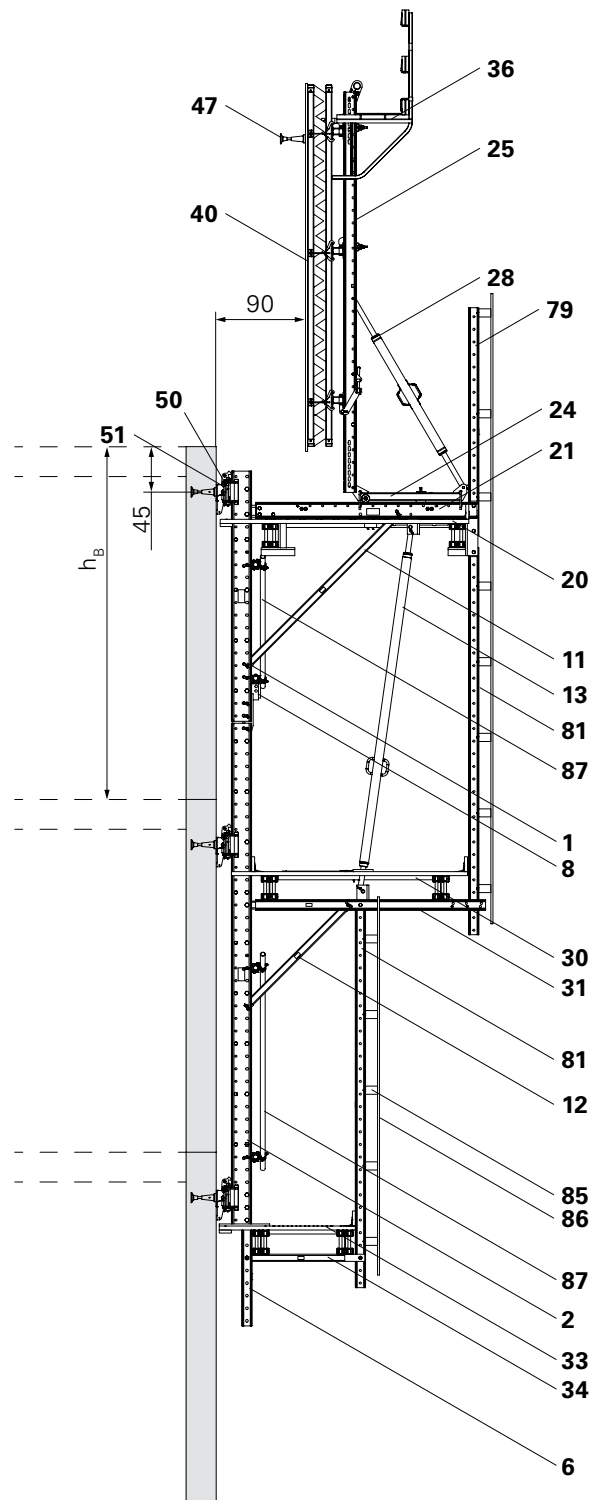

Fig. A1.03

Version 4:

Use with VARIO formwork and handrail boards.

$h_B = 4.50$ m.

(Fig. A1.04)

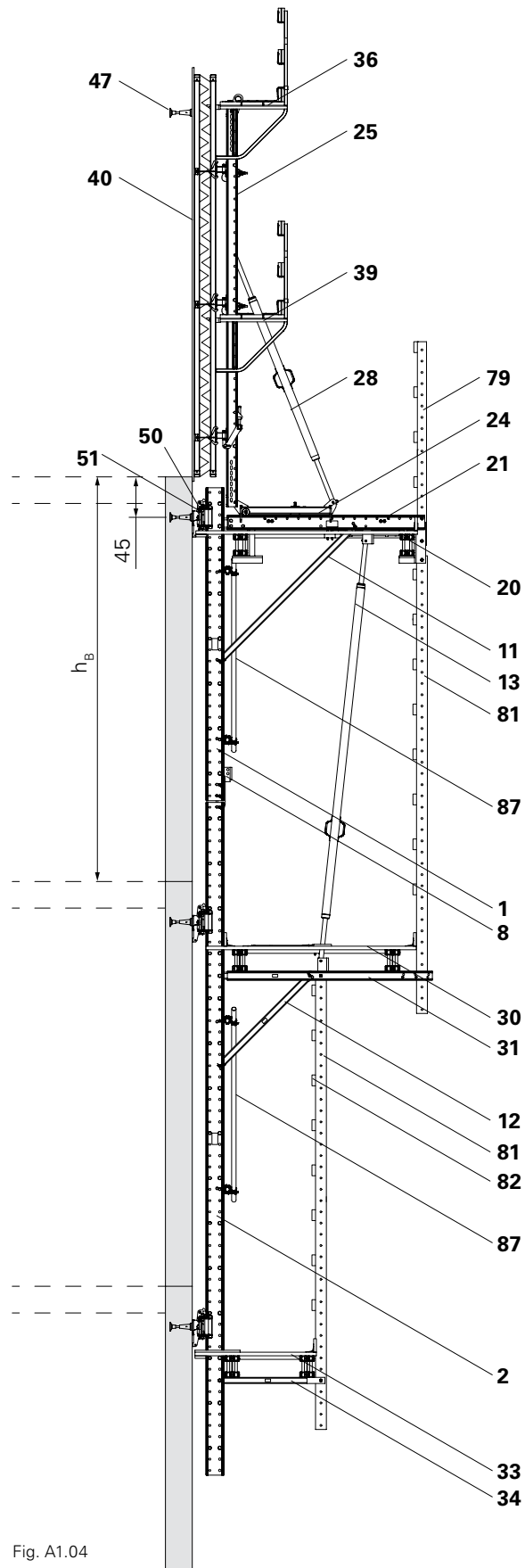

Fig. A1.04

General



Further information is provided in the following sections as well as in the separate Assembly Instructions for the RCS Climbing Device and Hydraulics.

Climbing Device RCS 50

The Climbing Device RCS 50 facilitates gradual climbing of the climbing formwork.

After the climbing procedure is completed, the climbing formwork must be placed on the climbing pawls of the climbing shoes ensuring that the load is fully supported. The Climbing Device must be load-free.

(Fig. A2.01 + A2.02)

Main components

- 60** Climbing Device RCS 50 1*
- 60.1** Piston with claw and roller
- 60.2** Cylinder base
- 60.3** Return from the piston rod side with the Quick Coupler Nipple RCS left and right, with protective cover
- 60.4** Inflow to the piston base with the Quick Coupler Bushing RCS left + right, with protective cover
- 60.5** Cylinder reposition device (spring-loaded)
- 60.6** Locking lever (spring-loaded)

The quick couplers on the Climbing Device and Hydraulic Pump are interchangeable.

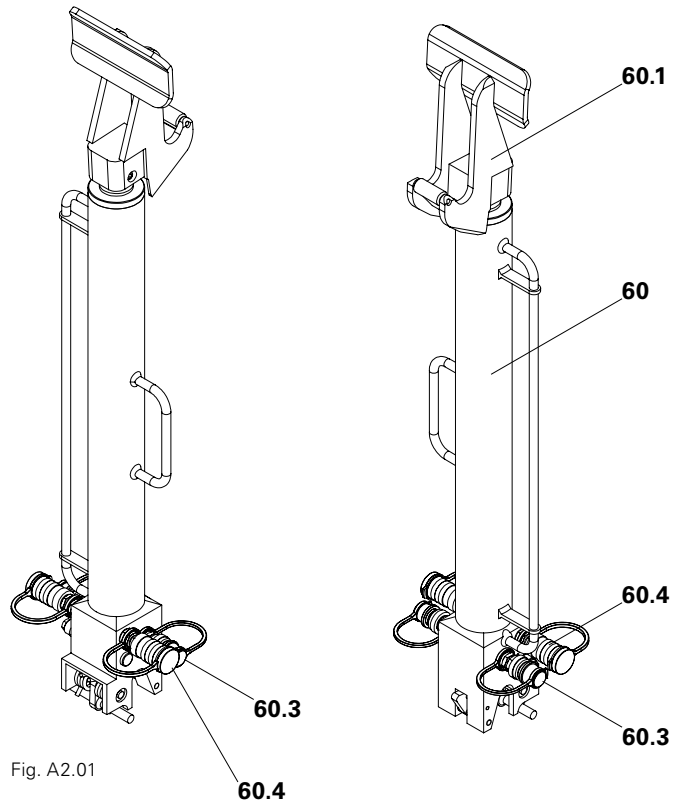

Fig. A2.01

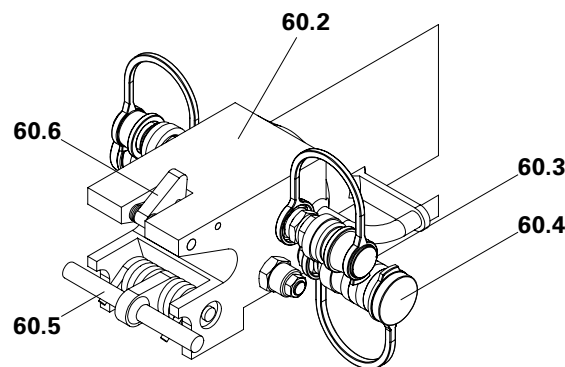

Fig. A2.02



In order to prevent the quick couplers from colliding with the platforms or other parts of the climbing protection panel when climbing, it is possible to equip the couplers vertically using angle pieces.

→ Contact PERI.

¹* safety components.

Hydraulic Pump

Hydraulic Pump RCS 4 x 190 bar,
380 – 460 V (63) for 4 Climbing
Devices RCS 50 1*
(Fig. A2.03 + A2.03a)

Main components

- 63** Hydraulic Pump RCS
4 x 190 bar, 380 - 460 V
- 63.1** Operating lever
- 63.2** Switch unit
- 63.3** Electricity socket with phase
inverter
- 63.4** Hydraulic oil tank
- 63.5** Filling piece
- 63.6** Oil level indicator; thermometer
- 63.7** Return flow filter
- 63.8** Return from the piston rod side
of the cylinder with the Quick
Coupler Bushing RCS
- 63.9** Inflow to the piston head side of
the cylinder with Quick Coupler
Nipple RCS
- 63.10** Rotary field control lamp

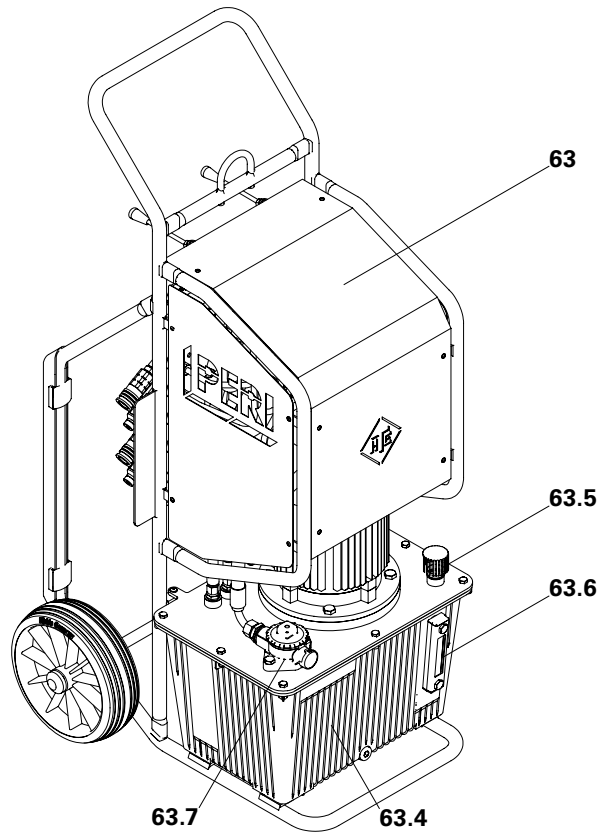

Fig. A2.03

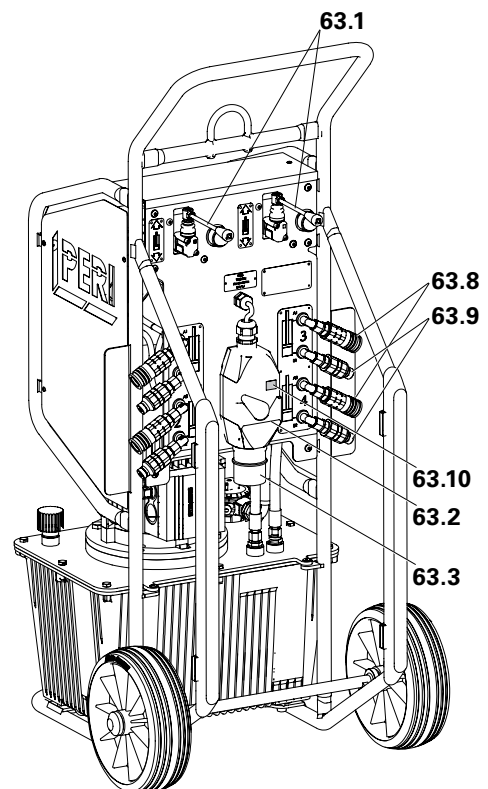

Fig. A2.03a

¹* safety components.

Accessories

(Fig. A2.04 + A2.05)

- 64** Adapter Cable RCS for supply line with CEE socket
- 65** Plug Socket RCS, black, for mounting an adapter cable

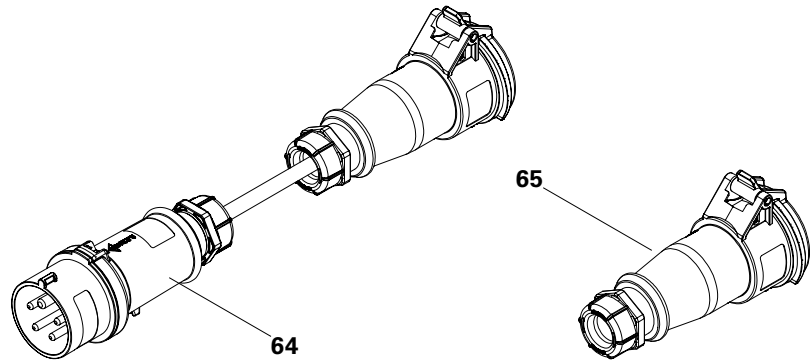

Fig. A2.04

Fig. A2.05

Hydraulic hose

The hydraulic twin hose is available in lengths L = 10 m and 20 m.

(Fig. A2.06 + A2.07)

- 61** Hydraulic Twin Hoses RCS 10 m
- 62** Hydraulic Twin Hoses RCS 20 m
- 61.3** Quick-Coupler Bushing RCS
- 61.4** Quick-Coupler Nipple RCS

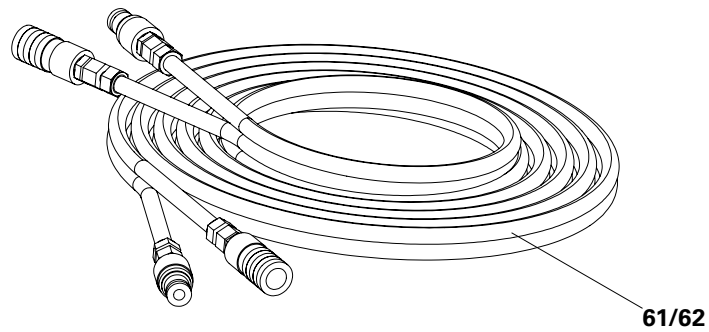

Fig. A2.06

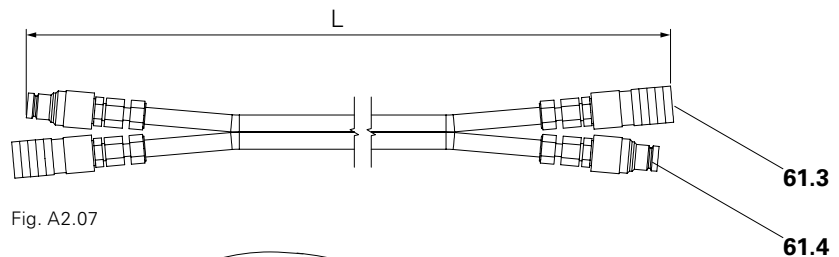

Fig. A2.07

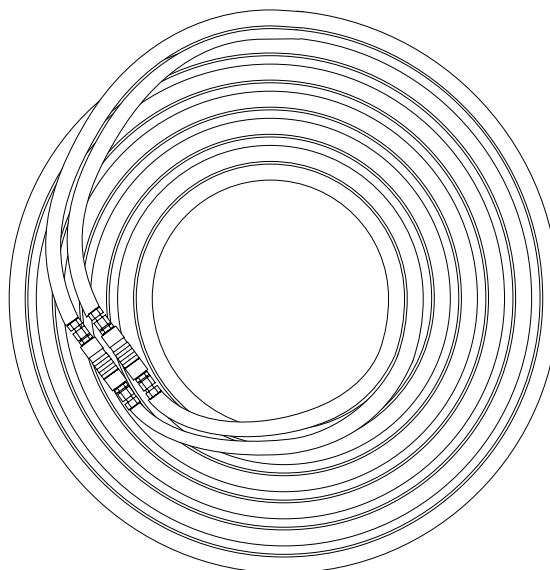

Fig. A2.08



During transport, join the two coupling ends together in order to protect the hoses. (Fig. A2.08)

Operating status: working

Work required to be carried out on the climbing formwork and working platforms:

- Cleaning of formwork, reinforcing of walls, closing the formwork, concreting and striking, inspection and maintenance.
→ Platforms must be freely accessible for the required work to be carried out.
- Moving forward and retracting the formwork on the carriage.
- Max. wind speed 102 km/h (dynamic wind pressure $q = 0.50 \text{ kN/m}^2$).
- Loads are evenly distributed. Single-sided loads on cantilevered platform areas are only allowed if an appropriate fixation against lift-off is fitted to the bracket positioned opposite.

Operating status: climbing

Moving the climbing unit by crane or by means of the hydraulic climbing device.

- The formwork is retracted on the carriage.
- Non-planned loads on the platforms are to be removed.
- Climbing with the crane: **personnel are not allowed on the platforms during the climbing procedure.**
- Self-climbing: personnel required for climbing operations are usually positioned on the neighbouring platforms. When climbing the last platforms of a cycle or during a manual intervention in the self-climbing procedure, it is necessary to enter the platform to be climbed.
- Max. wind speed 72 km/h (dynamic wind pressure $q = 0.25 \text{ kN/m}^2$).
- The climbing position must be statically verified as it can prove to be decisive.



Only the operating personnel may remain on the climbing unit during the climbing procedure.

Non-operational

During longer work breaks, overnight, in the case of storm warnings, with wind speeds over 129 km/h:

- Move the formwork on the carriage to the concreting position.
- Materials and equipment are to be removed from the working platforms.
- In the event of sudden storms or lightning, precautionary measures are to be taken only if they do not endanger site personnel in any way. Otherwise leave the climbing formwork immediately.
- Accessing the platform during storm conditions is prohibited.
- The assumed wind speed (dynamic wind pressure) during storm conditions is calculated based on the respective application height, wind zone and terrain category according to DIN EN 1991-1-4 or EC 1.
- If given limits are exceeded, a visual inspection of all bearing components and a functional check of all safety components is to be carried out for further use.
- If a storm warning is given with wind speeds higher than assumed, then an authorised person must be informed. If necessary, all enclosure tarpaulins are to be removed.
- On the instructions of authorised site personnel, the climbing formwork can be climbed down to the previous storey. Additional instructions are required for this. Remove materials and equipment from the platforms.

Overview of live loads



The support structure for these loads and conditions must be verified by means of a static calculation based on PERI product information.

Overview of live loads						
Platform	Working				Climbing	Non-operational
	Reinforcement work	Cleaning	Concreting	Preparation		
Concreting platform	75 kg/m ²		150 kg/m ²			
Working platform	300* kg/m ²	150 kg/m ²	150 kg/m ²			200 kg/m ²
Intermediate platform				150 kg/m ²	150 kg/m ²	
Finishing platform		150 kg/m ²		75 kg/m ²		
Max. wind speed	102 km/h				72 km/h	129 km/h
Position of the formwork carriage	Retracted or in a concreting position				Retracted	Concreting position

* The maximum live load of the working platform can be reduced to 200 kg/m² (see planning).

Concreting the Starter

All versions can basically be climbed by crane or using the hydraulic climbing device.

When climbing with a crane, however, the weight of the units may be limited due to the crane load-bearing capacity.

When climbing with the hydraulic climbing device, the weight is theoretically limited to 9 t.

Hydraulic climbing operations are only possible from the third working cycle.

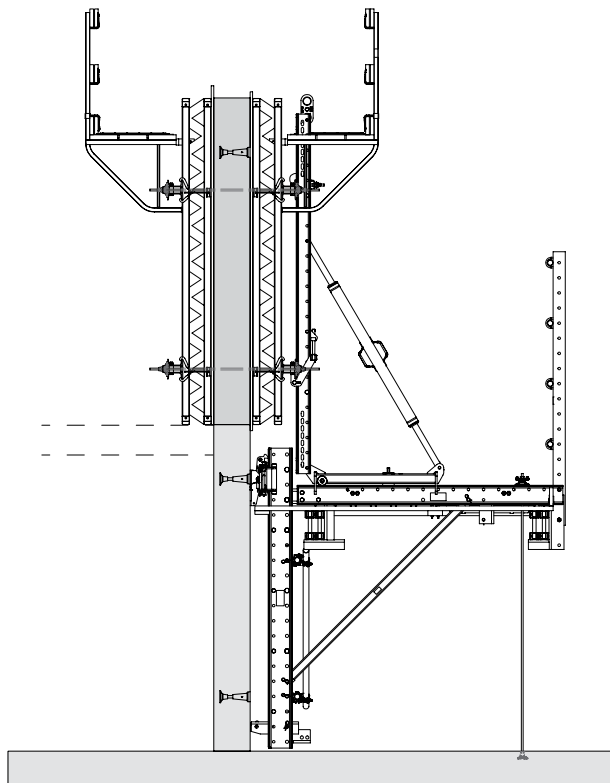

Fig. A4.01

1st working cycle

Mount the working platform on the first concreting section, brace and install the formwork. Reinforcement work and concrete the second section.

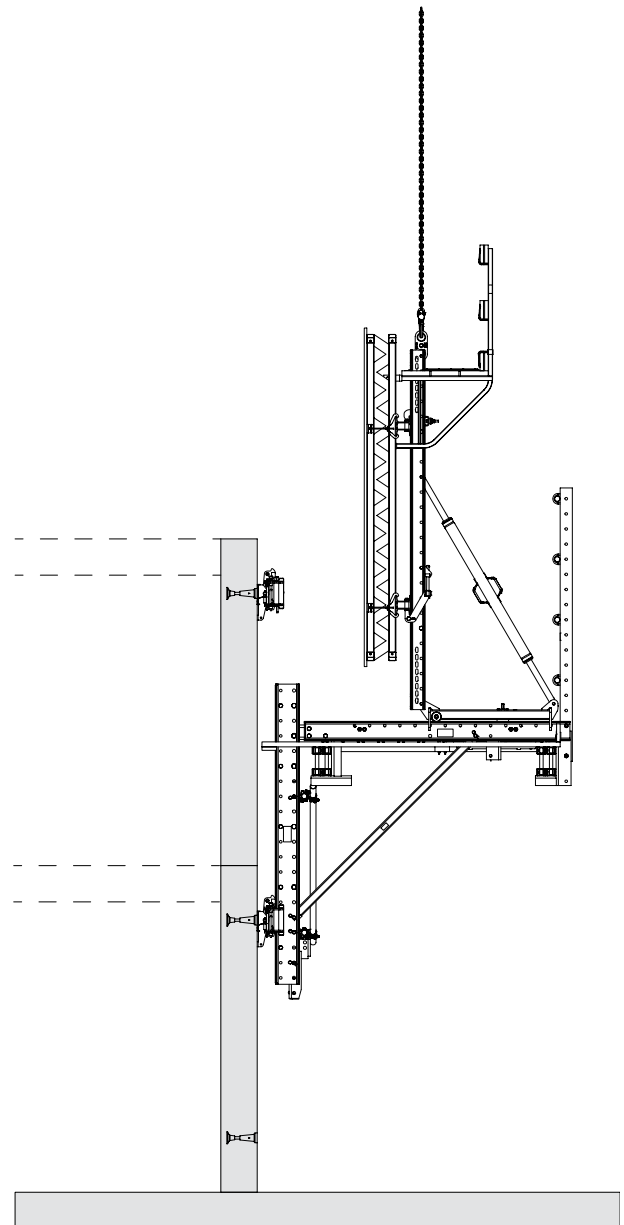

Fig. A4.02

2nd working cycle

Move the working platform by crane to the second concreting section.

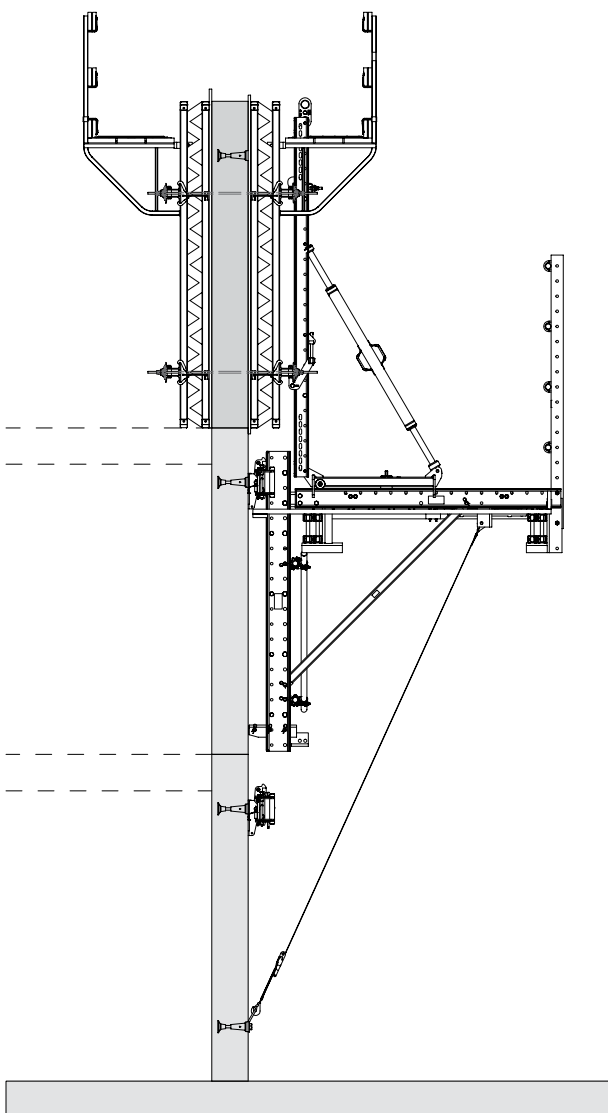

Fig. A4.03

3rd working cycle

Brace the working platform, position formwork, reinforce and concrete the third section.

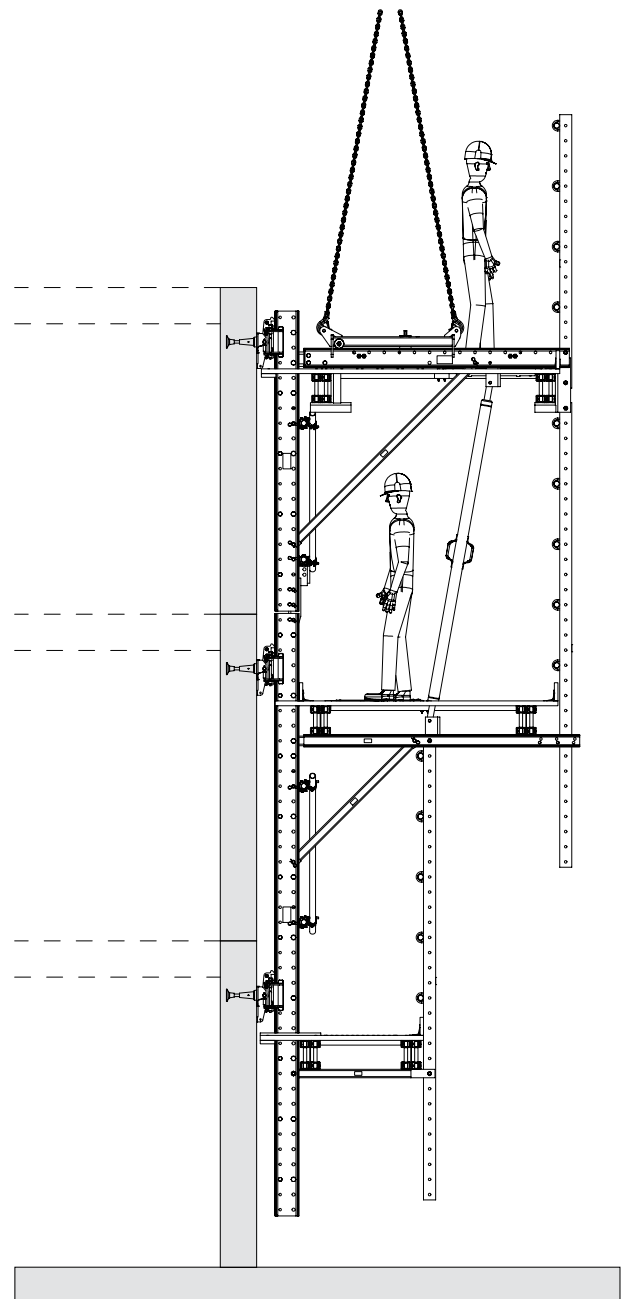

Fig. A4.04

4th working cycle

Dismantle formwork, remove the working platform from the wall, add climbing and finishing platforms and mount on structure. Climb the climbing formwork to the first standard section.

Concreting a standard section

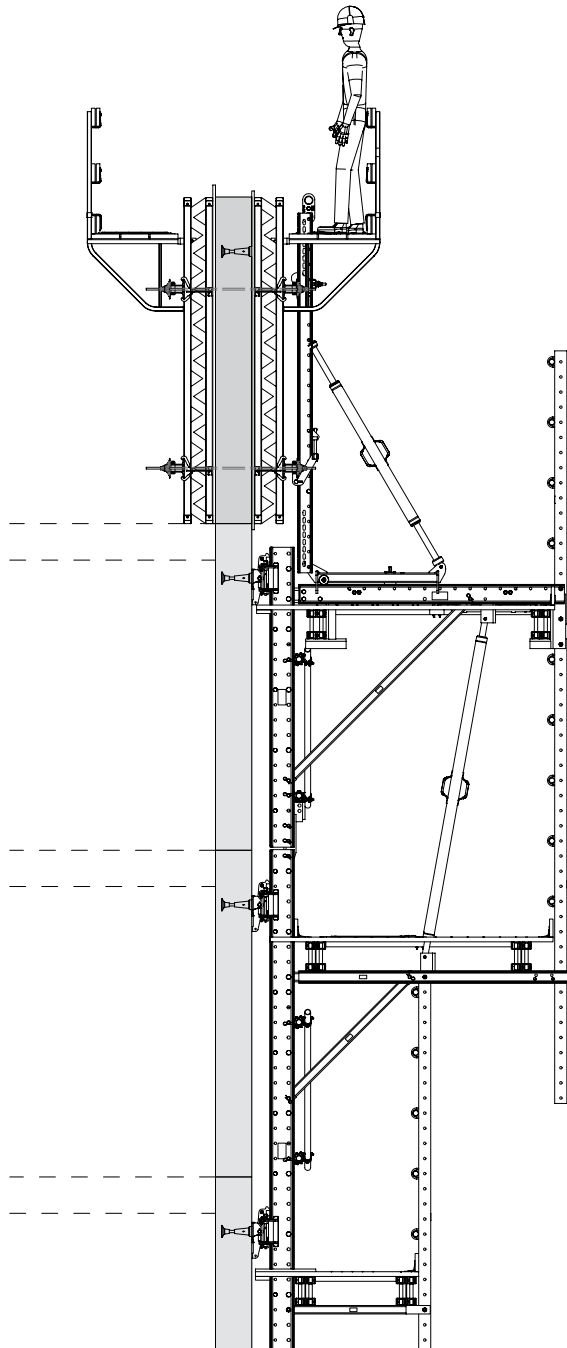

Fig. A4.05

5th working cycle

Position formwork, reinforce and concrete the standard section.

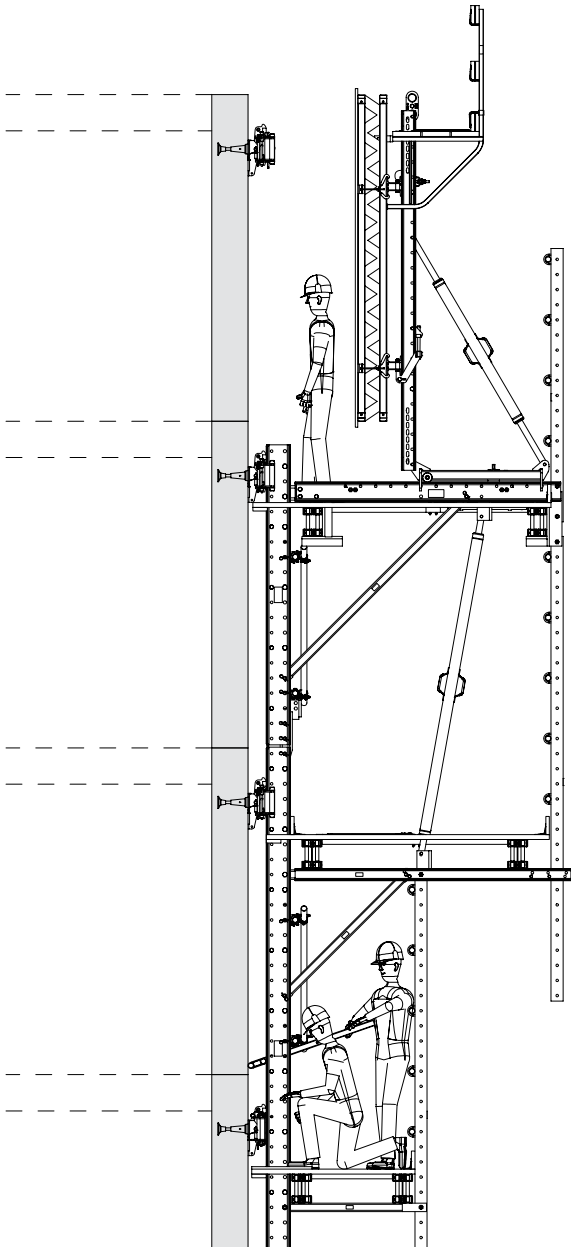

Fig. A4.06

6th working cycle

Dismantle the trailing anchoring and mount the Leading Anchor.

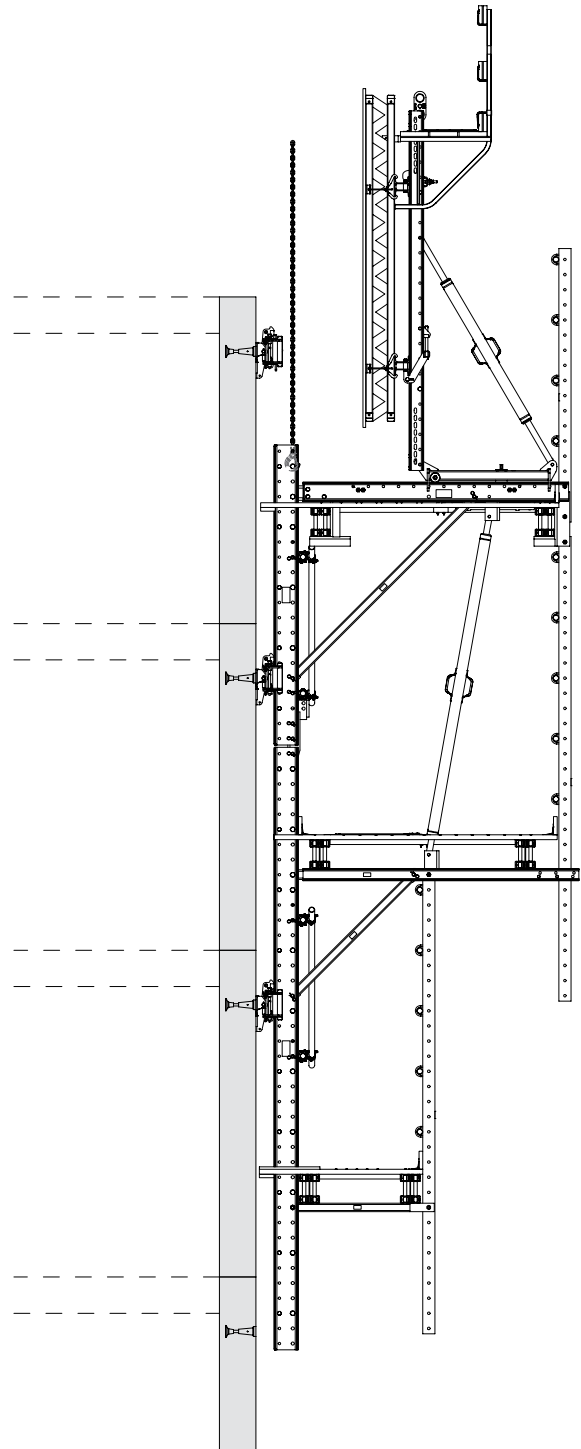

Fig. A4.07

7th working cycle

Climb the climbing formwork to the next standard section with the crane (see Fig. A4.07) or using the hydraulic climbing device.

System Dimensions

Climbing Rails

Depending on the height of the storey $h_{B'}$, combine the Climbing Rails so that at least 2 Climbing Shoes guide the Climbing Rail at all times.

The total length of the Climbing Rails L must therefore correspond to at least the maximum height of two consecutive storeys $h_{B1} + h_{B2}$ plus overlap.

Total length

with Climbing Rail Extension:

$$\text{min. } L = h_{B1} + h_{B2} + 48 \text{ cm,}$$

without Climbing Rail Extension:

$$\text{min. } L = h_{B1} + h_{B2} + 98 \text{ cm.}$$

Example

Climbing Rails 2.48 + 4.98 m with Climbing Rail Extension:

Total length of the Climbing Rails $L = 2.48 + 4.98 + 0.02 = 7.48 \text{ m.}$

max. spacing of Climbing Shoe

$$h_{B1} + h_{B2} = 2.48 + 4.98 - 0.48 = 7.00 \text{ m}$$

The following applies for a constant storey height:

$$\text{max. } h_{B1} = h_{B2} = 3.50 \text{ m}$$

Overhang of the Guardrail Post above the Intermediate Platform Beam

min. 20 cm.

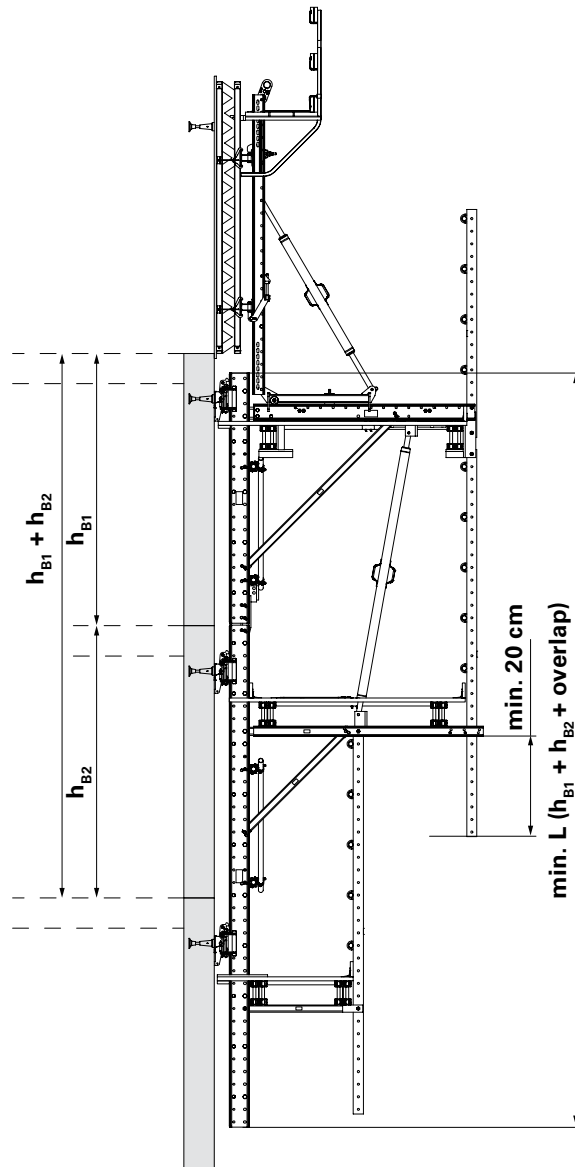

Fig. B1.01

Combination of the Climbing Rails			
Combination of the Climbing Rails	Climbing Rail Extension	Maximum spacing of Climbing Shoe $h_{B1} + h_{B2}$	With a constant storey height max. $h_{B1} = h_{B2}$
2.48 m + 4.98 m	with	7.00 m	3.50 m
	without	6.50 m	3.25 m
2.48 m + 7.48 m	without	9.00 m	4.50 m
3.48 m + 4.98 m	with	8.00 m	4.00 m
	without	7.50 m	3.75 m
3.48 m + 7.48 m	without	10.00 m	5.00 m

Framework Assembly

Climbing Rail spacing

The spacing between the Climbing Rails is determined and proven on a project-specific basis.



- The respective dimensions for the assembly are based on the specified design and must be included on separate assembly drawings.
- All separate connecting means which are not standard components must be identified.
- Use the supplied connecting means.

Anchoring and Starter height

The Starter height h_B is dependent on the formwork system used.

The platform unit must be braced at the Crossbeam Head in order to accommodate existing wind loads at ground level or a low-positioned anchor point. The load-bearing capacity of the ground must be verified.

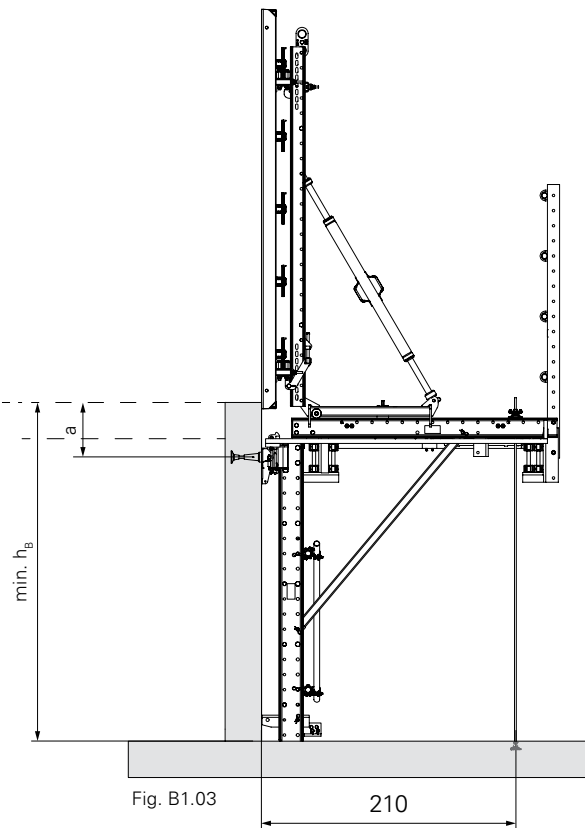
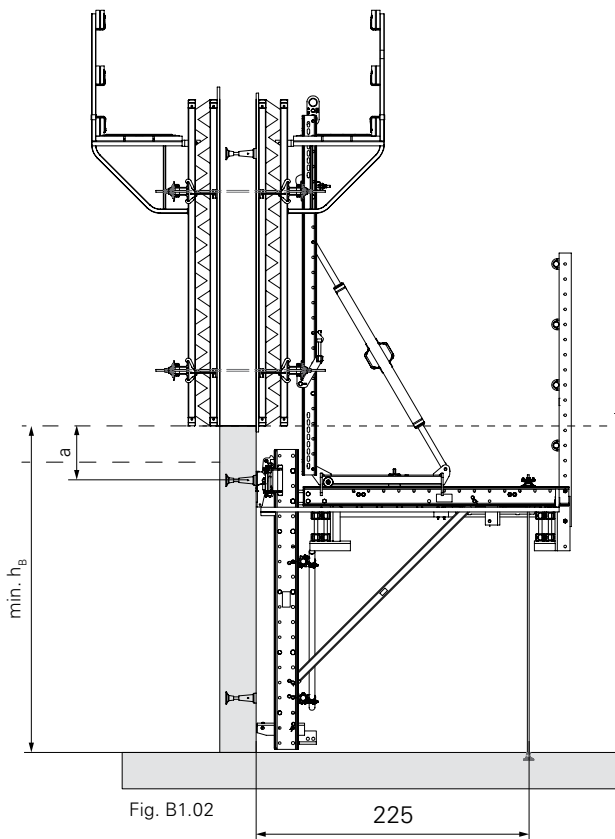

System dimensions			
	Crossbeam Head	RCS/VARIO	RCS/TRIO
Anchor spacing a		45 cm	45 cm
Length of the top Climbing Rails		Starter height min. h_B	
2.48 m		2.68 m	2.80 m
3.48 m		3.68 m	3.80 m

Additional Spacers

Spacers are mounted at a distance of 50 cm on the Climbing Rails. Additional Spacers M20-82 (**3**) can be installed on the Climbing Rail (**2**) as climbing bolts. This allows the height of the climbing formwork and working platforms to be adjusted in increments of 12.5 cm. (Fig. B1.04 + B1.05)

Spacers are used to support the climbing units on Slab Shoes during working operations.



PERI recommends mounting an additional Spacer M20-82 for the middle Slab Shoe for standard storey heights that are multiples of 50 cm. This ensures a definite bearing on the planned Climbing Shoe without having to deactivate the other Climbing Shoes.

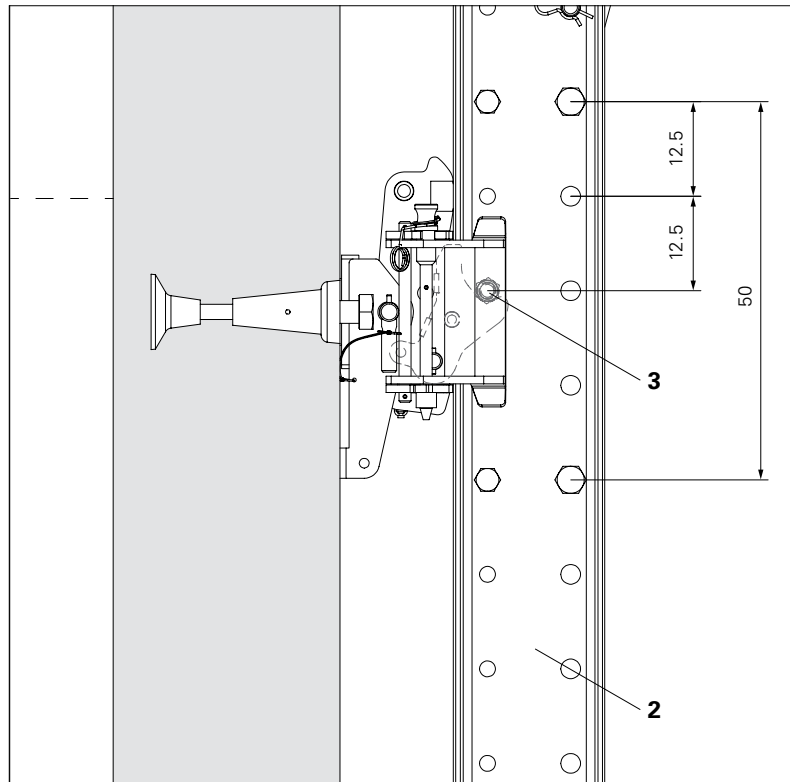

Fig. B1.04

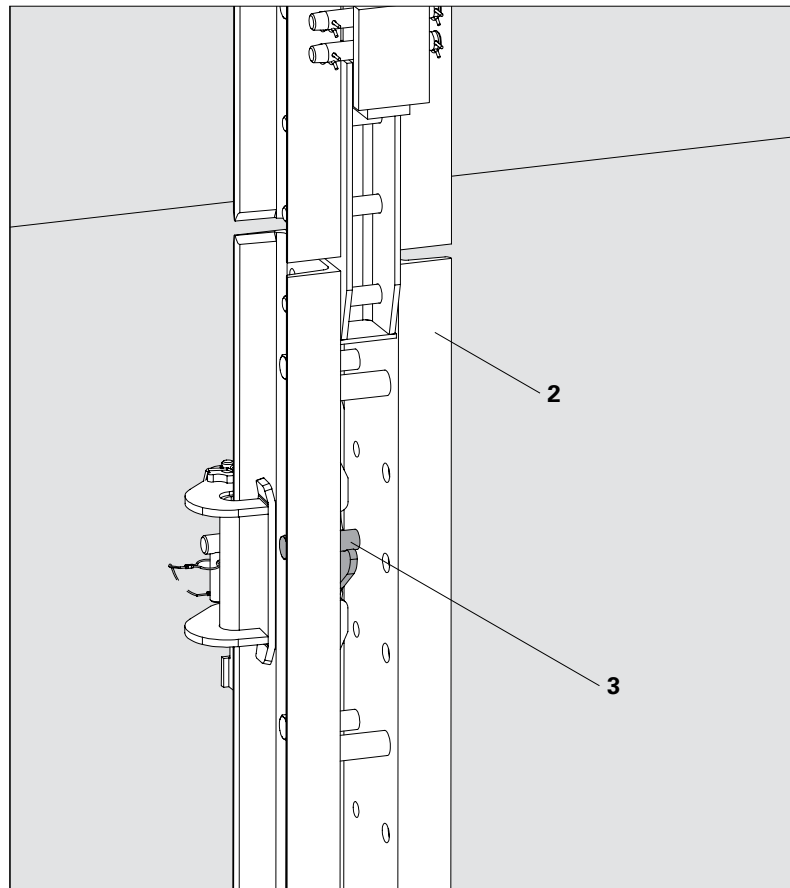

Fig. B1.05

Reaction Forces

H_{x1} : horizontal force on the top Slab Shoe (positive: tension, negative: compression).

H_{x2} : horizontal force on the bottom Slab Shoe (positive: tension, negative: compression).

V : vertical force on the bottom Slab Shoe.

The reaction forces that affect the anchorage and building are to be taken from the project-specific calculation.

The maximum reaction forces are to be shown on the general arrangement drawings.

For all decisive load cases, the anchorage and load transfer into the concrete as well as the transfer of forces into the building must be statically proven.

Load cases

A: Working conditions

wind load from wind suction with $q(z) = 0.50 \text{ kN/m}^2$
 ($v = 102 \text{ km/h}$),
 100 % live load on one level,
 50 % live load on a second level.

B1: Storm conditions

max. wind load from wind pressure $w_e > 0$,
 no live loads.

B2: Storm conditions

max. wind load from wind suction $w_e < 0$,
 no live loads.

B3: Storm conditions

max. wind load from wind suction $w_e < 0$,
 no live loads.

$$w_e = c_s \times \chi \times \sum (c_f \times q(z_e))$$

c_s = Site correction value

χ = service life factor for temporary constructions

c_f = force coefficient

$q(z_e)$ = peak velocity pressure

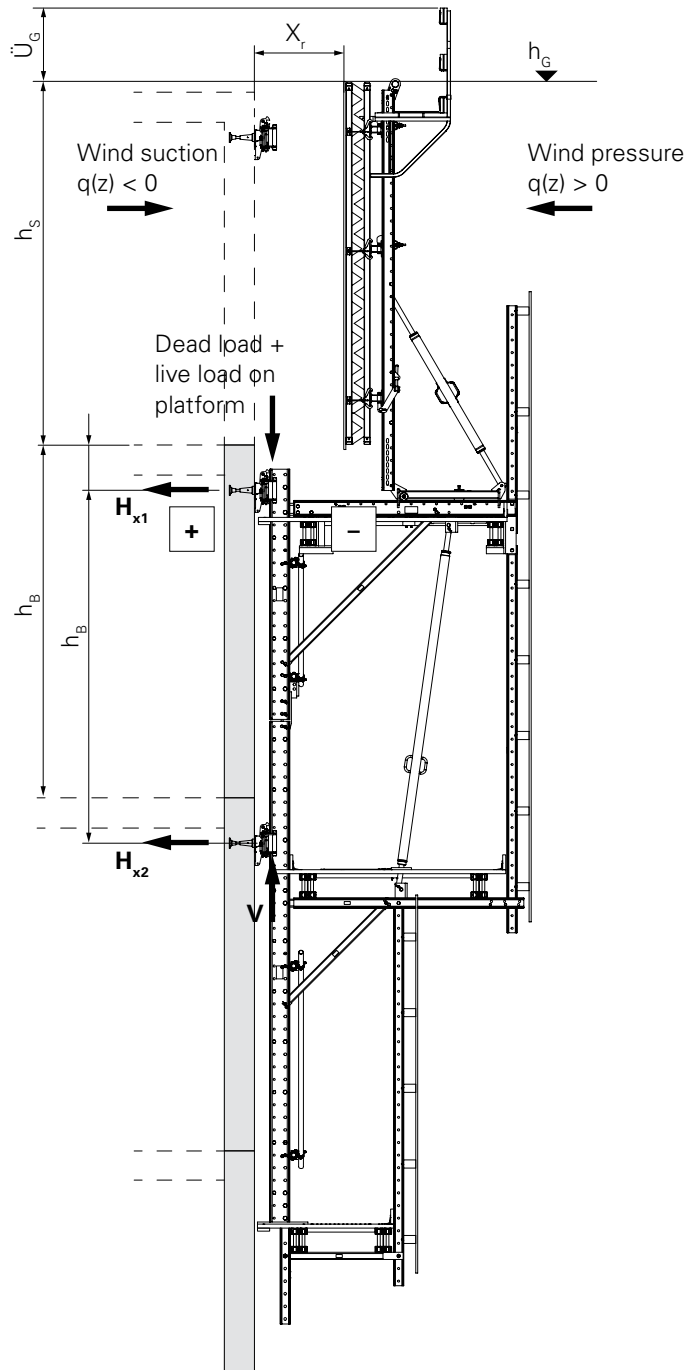

Fig. B1.06

General

- Platform decking is to be correctly realised and in accordance with applicable safety regulations.
- Material qualities must comply with all valid standards.
- Tripping hazards, unnecessary box outs and openings in the decking are to be avoided or covered.
- The distance between the bottom decking and the structure is a maximum 5 cm. Gaps in the decking may be a max. 2 cm.
- Gaps between the decking of neighbouring platforms must be fitted with immovable covering during work operations or use safety nets with a mesh width of max. 2 cm.
- Any openings in the decking which are required during work operations must be covered with non-movable suitable materials.
- Mount intermediate platforms in order to safely operate anchor points.
- The decking of all platforms is not designed for use as safety scaffold. The suitability as safety scaffold must be designed and proven on a project-specific basis. See also DIN EN 12811-1 as well as DIN 4420-1.

Planking for the working platform

Working scaffold of Load Class 4 max. load 300 kg/m² corresponds to DIN EN 12811-1, Table 3. Solid Wood Strength Class C24 – EN 338; conifer timber, Quality Class S10. Minimum dimensions of the planking: $w \times d = 24 \times 4$ cm or 20×4.5 cm.

PERI recommends that if the plank thickness is less than 45 mm, the individual planks should be fixed to the cantilever arm and in the middle of the bay using transversely positioned timber.

Minimum dimensions $w \times d = 12 \times 4$ cm.

Alternatively: Strength Class C16 for Solid Wood EN 338; minimum dimensions of the planking $w \times d = 24 \times 5$ cm.

Planking for the intermediate and finishing platforms

Working scaffold of Load Class 2, max. load 150 kg/m² in accordance with DIN EN 12811-1, Table 3. Solid Wood Strength Class C24 – EN 338 (conifer timber, Quality Class S10). Minimum dimensions of the planking: $w \times d = 20 \times 4$ cm.

PERI recommends that if the plank thickness is less than 45 mm, the individual planks should be fixed to the cantilever arm and in the middle of the bay using transversely positioned timber.

Minimum dimensions $w \times d = 12 \times 4$ cm.

Alternatively:

Strength Class C16 for Solid Wood EN 338; minimum dimensions of the planking $w \times d = 24 \times 5$ cm.



When using planking with a lower strength class or plywood sheets, static verification is required.

Girders

Girder dimensioning

Permissible span and cantilever of girders for the working, intermediate and finishing platforms: see Product Information PI 331.

Additional stiffening boards for the girders may be required.

Bracing the platforms

Fix diagonal planking under the platforms.

Bolted a minimum $w \times d = 20 \times 4$ cm.

Fixing per plank: 2x Torx TSS 6 x 80

Fixing the girder

The number of connecting means refers in each case to a support point. As a rule, the number stated is 4 x per platform.

Working platform with Crossbeam Head RCS/VARIO (22)

Crossbeam Unit RCS 220 VARIO (21)

Girder (here GT 24) (75)

Double girder position

Fix with 2x F.H. Bolt M8 x 200 MU (112) + washer (121).

Optional for securing against lifting: 2x TSS Torx 6 x 60 (126).

(Fig. B2.01 - B2.01b)



- Pre-drill girders when using F.H. Bolts M8 with $\varnothing 9$ mm.
- When using VT 20: Bolt the top chord to the Crossbeam by means of the bottom hole (21.1). (Fig. B2.03)
- For cantilevers of more than 1 m, bolt the girders together on the top chord.

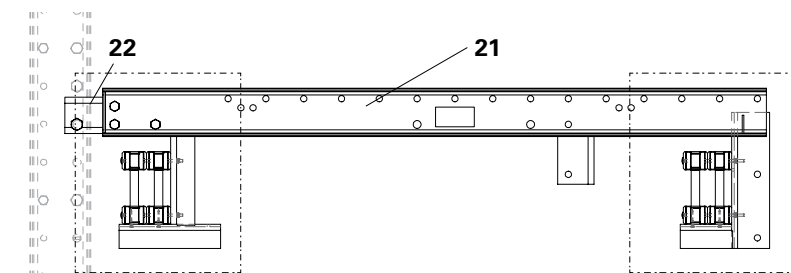

Fig. B2.01

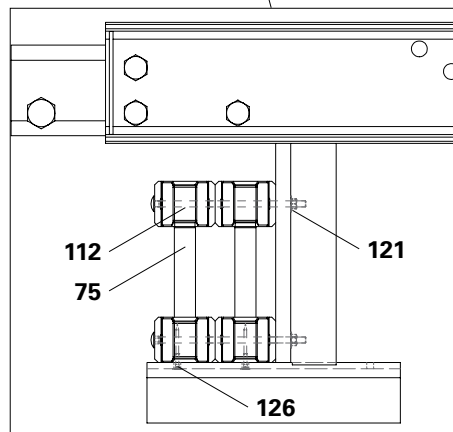

Fig. B2.01a

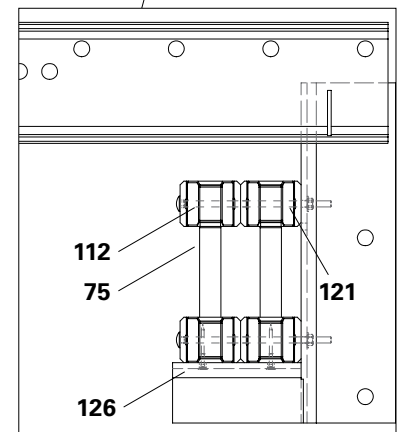

Fig. B2.01b

Single girder position

Fix with 2x F.H. Bolt M8 x 100 MU (110).
(Fig. B2.02 - B2.02b)

Optional for securing against lifting:
1x TSS Torx 6 x 60 (126).



- Pre-drill girders when using F.H. Bolts M8 with \varnothing 9 mm.
- When using VT 20:
Bolt the top chord to the Crossbeam by means of the bottom hole (21.1).
(Fig. B2.03)
- For cantilevers of more than 1 m,
bolt the girders together on the top chord.

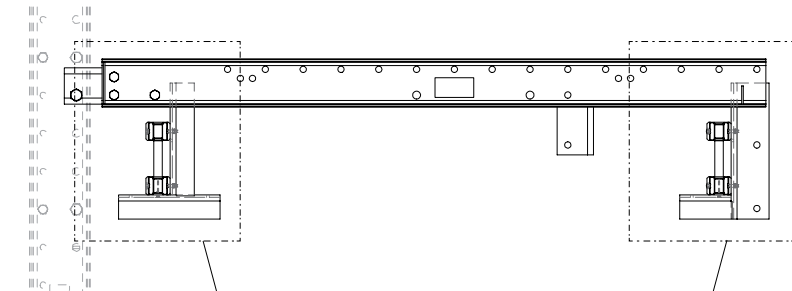

Fig. B2.02

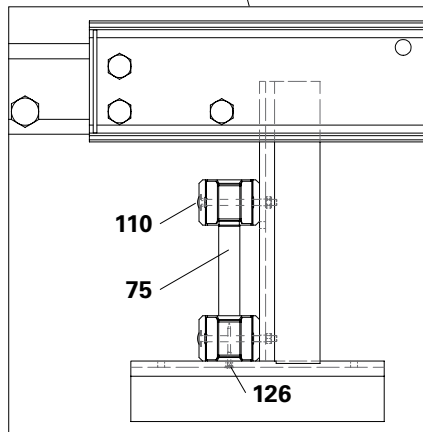

Fig. B2.02a

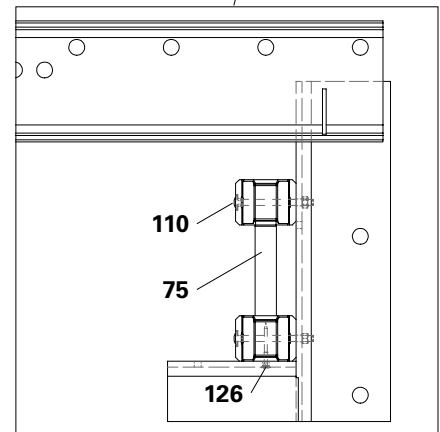

Fig. B2.02b

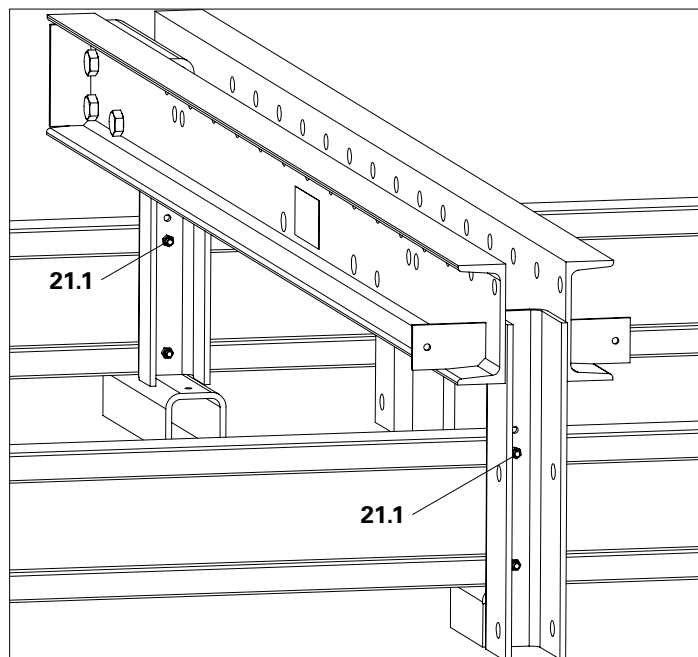

Fig. B2.03

Intermediate and finishing platforms

Here: Intermediate Platform Beam (**31**),
Girder (here GT 24) (**75**).

Single girder position:

Fix with

4x hex. wood screws 8 x 80 (**138**);
alternatively with TSS Torx 6 x 80 (**125**).
(Fig. B2.04 - B2.04a)

Double girder position:

Fix with

2x F.H. Bolt M8 x 200 MU (**112**) +
washer (**121**).

(Fig. B2.05 + B2.05a)



- Pre-drill girders with \varnothing 9 mm when using F. H. Bolts M8.
- Pre-drill girders with \varnothing 5 mm when using wood screws \varnothing 8 mm.
- Do not pre-drill the girders when using TSS Torx 6 x 80.

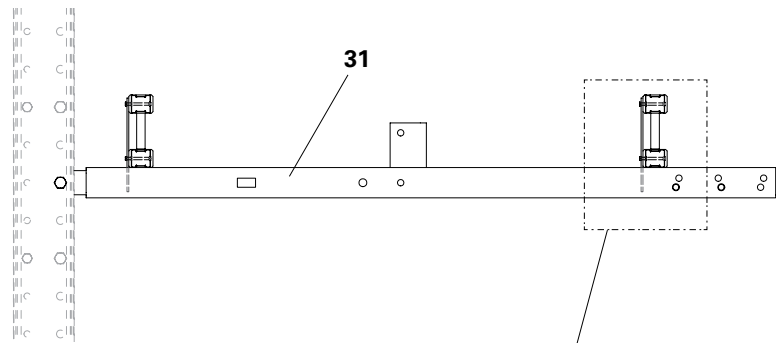

Fig. B2.04

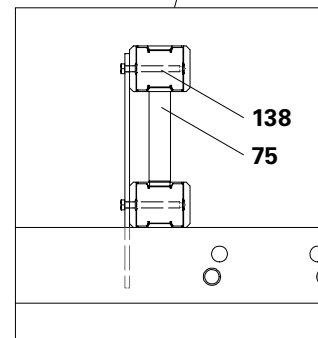

Fig. B2.04a

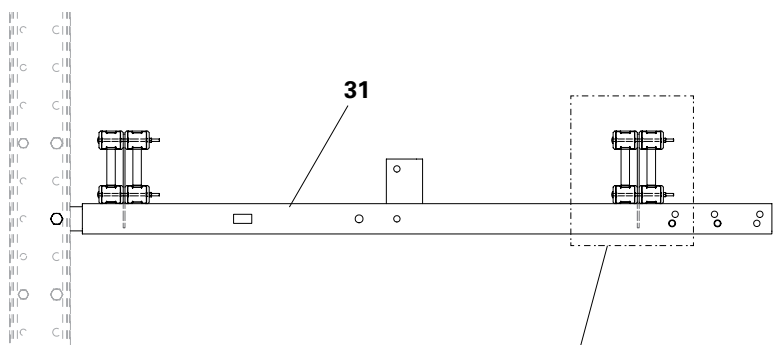

Fig. B2.05

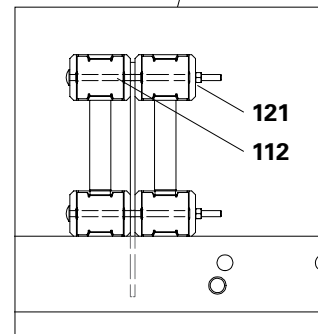

Fig. B2.05a

Planking

Assembly

Fix each plank (76) at each point where it crosses the girder (75) using 2x Torx 6 x 80 (125). $e = 120$ mm.



Secure cantilevered planking and the respective girder against lifting using suitable fixing means!

For larger cantilevers than specified in Product Information PI 331, static proof is required.

In mitred and cut-out areas where two-sided support of the planking is not guaranteed, mount laminated wood panels.

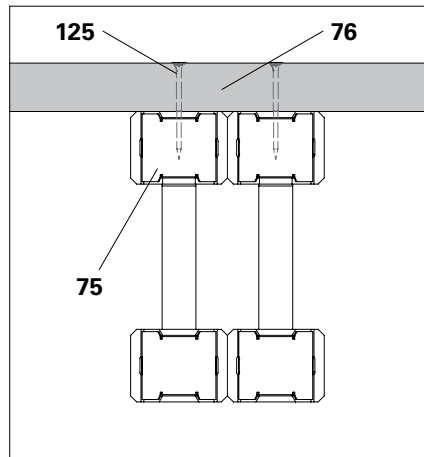

Fig. B2.06

Front view

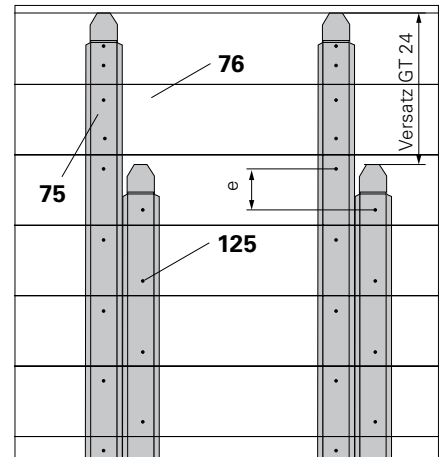

Fig. B2.07

Top view

Toeboards

Requirements:

Toeboards made of Solid Wood C24. Minimum dimensions $d/b = 3/15$ cm, shown here planking (76) of the working platform.

Assembly

Alternative 1:

Secure the Toeboard (77) with continuous timber 6/6 cm (98) and Torx 6 x 80 (125) and Spax 6 x 100 (132) at a spacing of approx. 50 cm.

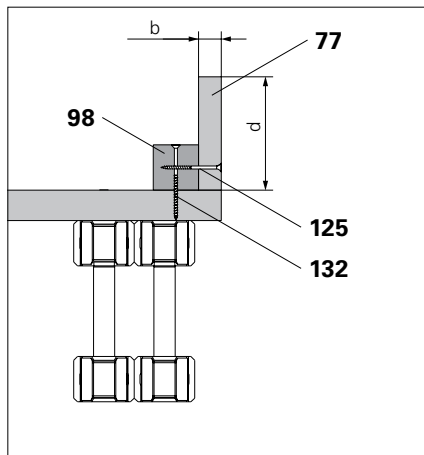

Fig. B2.08

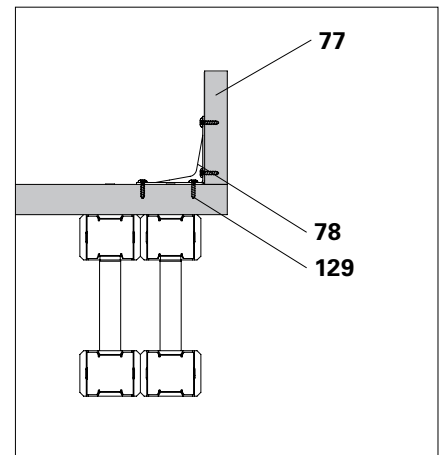

Fig. B2.09

Alternative 2:

Fix the Angle Bracket 90° (78) to the Toeboard (77) at a spacing of approx. 1 m using 4x TSS Torx 5 x 20 (129).

Fix every Angle Bracket to the planking using 4x 5 x 20 (129).

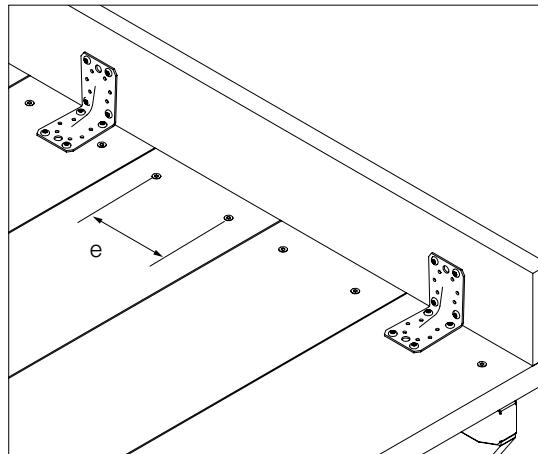

Fig. B2.10

Working Platforms

Application for VARIO and TRIO formwork. (Fig. B2.11 + B2.11a)

Opening for the hatch cover

Opening in the decking 57 x 72 cm for the hatch (66).

Bracing 120/40 mm, fix laterally on continuous planking using min. 4x F.H. Bolts DIN 603 M8 x 125 (114) + washer A8 ISO 7093 (120).
Drilled hole \varnothing 8 mm.

Recommended distance to the building 50 mm;
to neighbouring platform 30 mm.

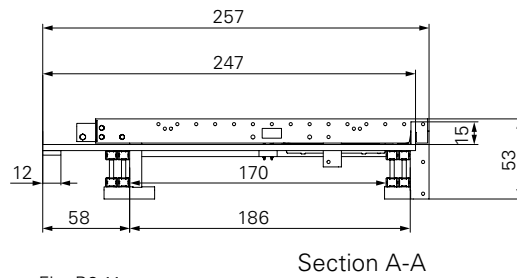

Fig. B2.11a

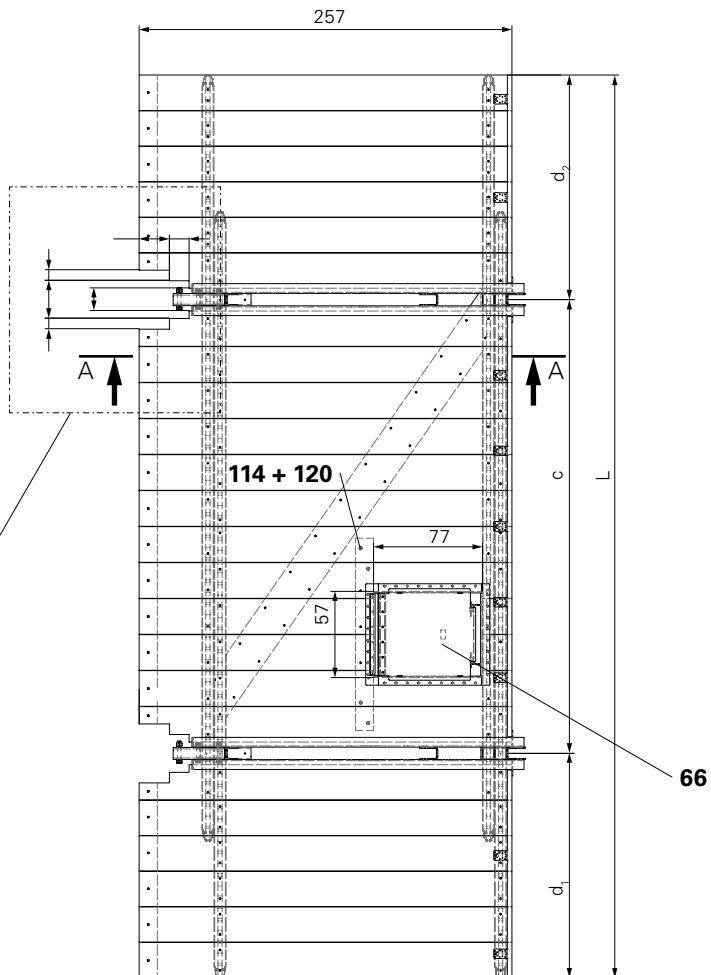
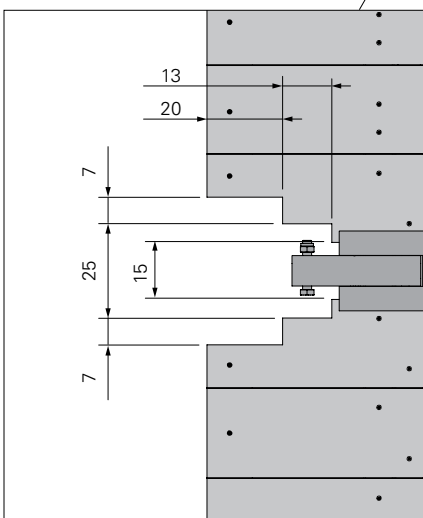

Fig. B2.11



Intermediate Platforms

Application for VARIO and TRIO formwork. (Fig. B2.12 + B2.12a)

Close the recess $\varnothing 100$ mm in the planking in the area of the SLS Spindle with formlining as covering (**76.1**). (Fig. B2.12c).

Fix the covering to the decking.

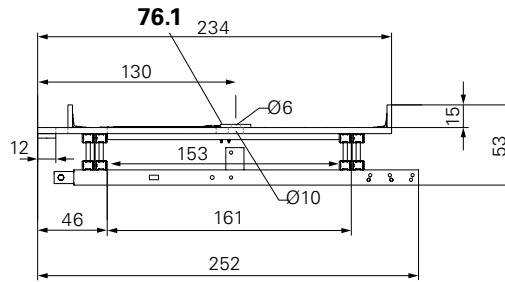

Fig. B2.12a

Section A-A

Opening for the hatch cover

Opening in the decking 57 x 72 cm for the hatch (**66**). Replacement 120/40 mm, fix laterally on continuous planking using min. 4x F.H. Bolts DIN 603 M8 x 125 (**114**) + washer A8 ISO 7093 (**120**). Drilled hole $\varnothing 9$ mm.

Recommended distance to the building 150 mm; to neighbouring platform 30 mm. If necessary, close the gap to the structure with elastomer cover strip.

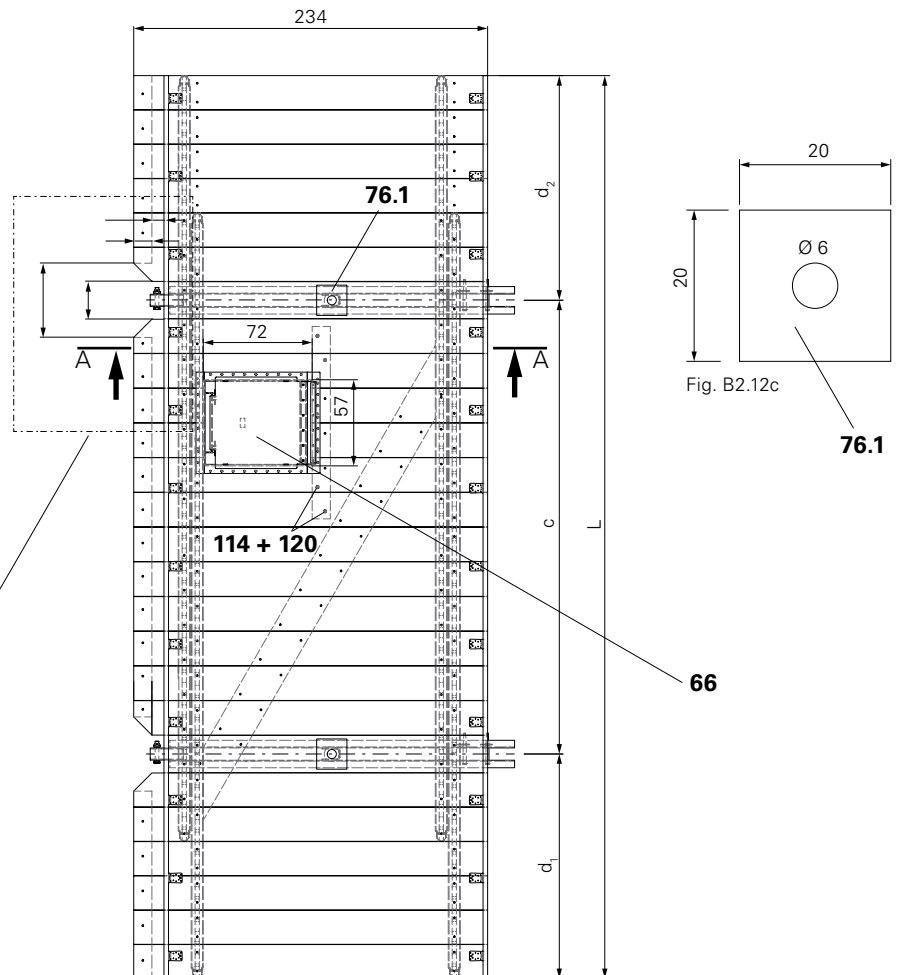

Fig. B2.12c

76.1

66

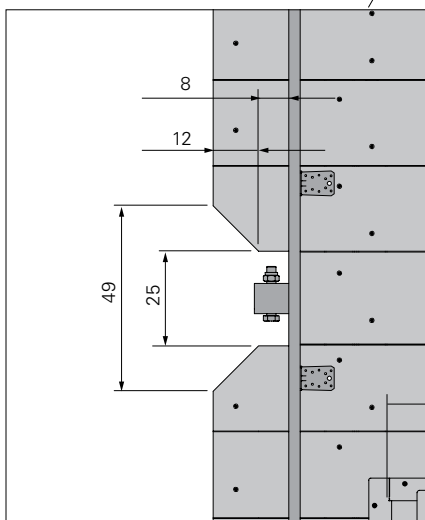
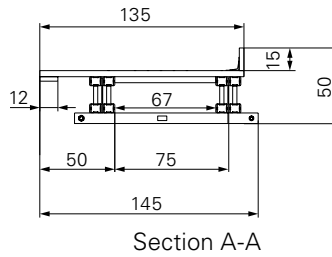

Fig. B2.12

Finishing Platform

So that the girder does not have to be realised as a special length, use double girders which have been pushed together.
(Fig. B2.13)



Section A-A
Fig. B2.13a

Deck covering

For Climbing Rails and Climbing Rail Extensions, use deck covering cut to size and fix to pre-assembled planking by means of TSS Torx 6 x 60 screws (126).

Covering for the Climbing Rail.
(Fig. B2.13b)

Covering for the Climbing Rail Extension. (Fig. B2.13c)

Recommended distance
to the building 50 mm;
to neighbouring platform 30 mm.

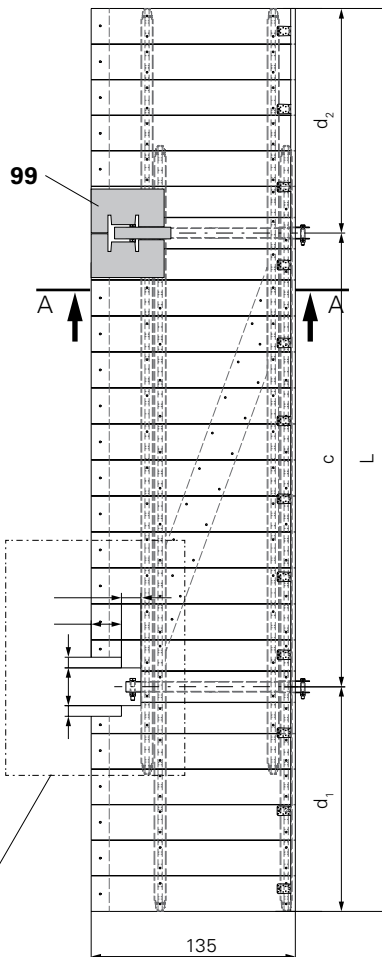

Fig. B2.13

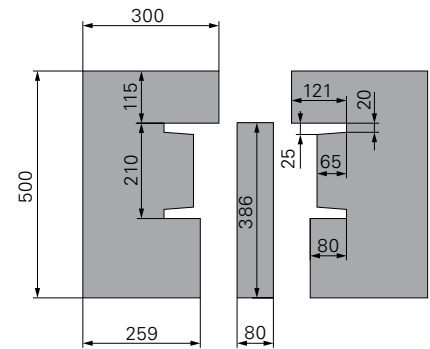

Fig. B2.13b

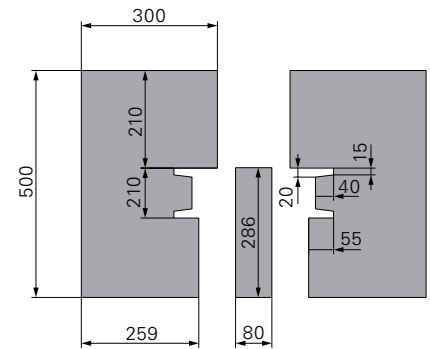
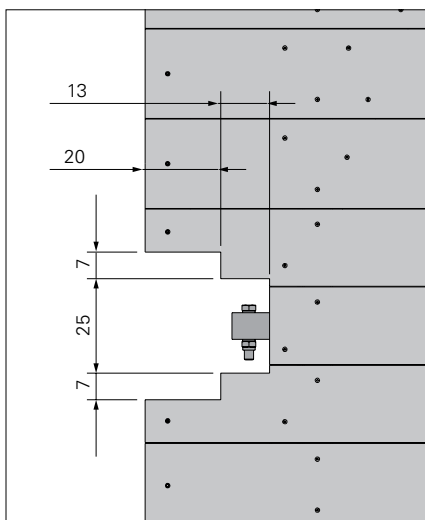

Fig. B2.13c



General

Ensure that the decking on the corner and internal platforms does not interfere with the climbing procedure. Mount lateral guardrail protection on the front side, see Section "Lateral guardrail protection" on page 50. All dimensions are examples and must be checked and defined according to project requirements.



Secure all cantilevered platforms on the opposite side against lifting.

Working platforms

When the formwork is retracted (shaded area b_1), the transition area from one platform to another must be possible to realise without any problems. Do not fall below the passage width of min. 50 cm.

Mitred working platform, supported

Push girder up to the edge of the platform. Fix cantilevered planking to planks that are positioned laterally to the direction of the planking (A). Alternatively for the corner areas, mount laminated wood panel (B). Cover the gap between the mitred elements. (Fig. B3.01)

Overlapping working platform

Covering platform gaps. (Fig. B3.02 + B3.03)



In order to maintain the permissible cantilevers of the platform beams, minimise the distance from the bracket to the corner on the protruding platform.

Attention – a more exact static proof of the anchoring may be required.

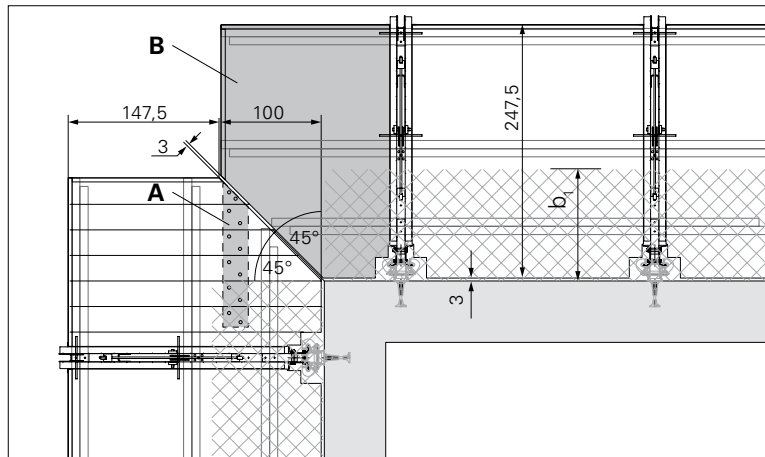

Fig. B3.01

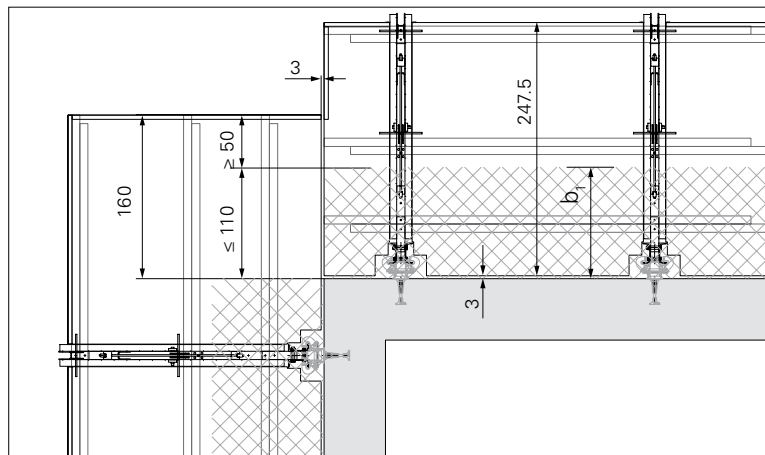

Fig. B3.02

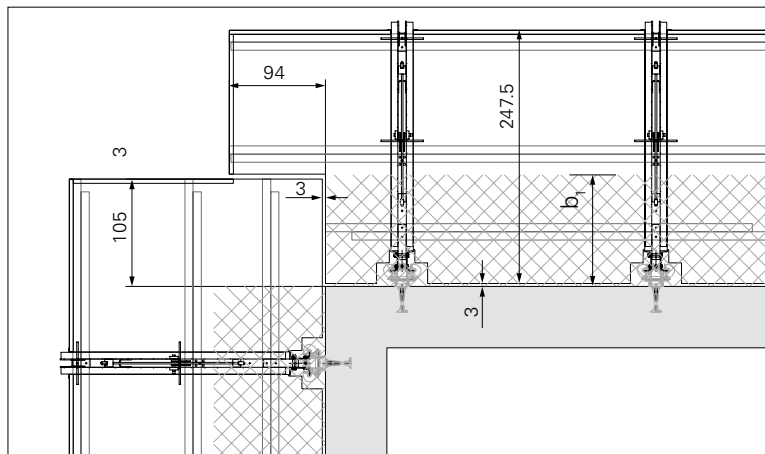

Fig. B3.03

Intermediate Platforms

The transition area from one platform to another must be possible to realise without any problems. Do not fall below the passage width of min. 50 cm. With enclosed climbing formwork, the side wind load on corner platforms is kept to a minimum through an open, multi-part design of the lateral guardrails. PERI recommends scaffold tube bracing.

Mitred intermediate platform

Push girder up to the edge of the platform. Fix cantilevered planking to planks that are positioned laterally to the direction of the planking (**A**). Alternatively for the corner areas, mount laminated wood panel. Cover the gap between the mitred elements (**B**). (Fig. B3.04)

Overlapping intermediate platform

Bring platform decking of the overlapping platform in the transition area up to the neighbouring platform. If necessary, fix cantilevered planking to timbers (**A**) that are positioned laterally to the direction of the decking. Cover any remaining platform gap. (Fig. B3.05)

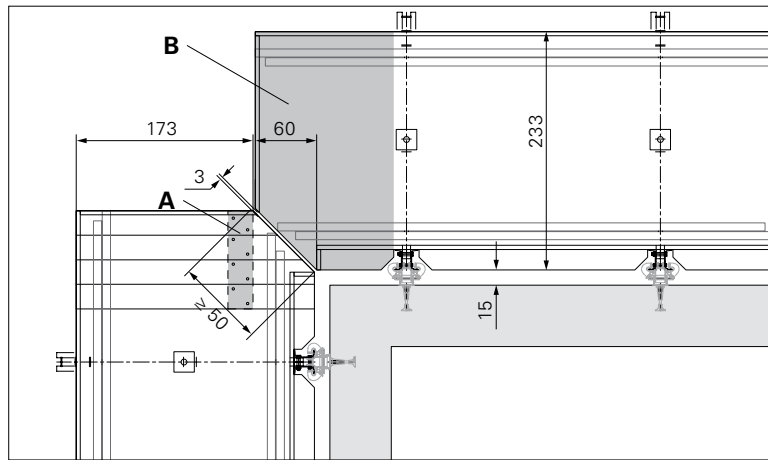

Fig. B3.04

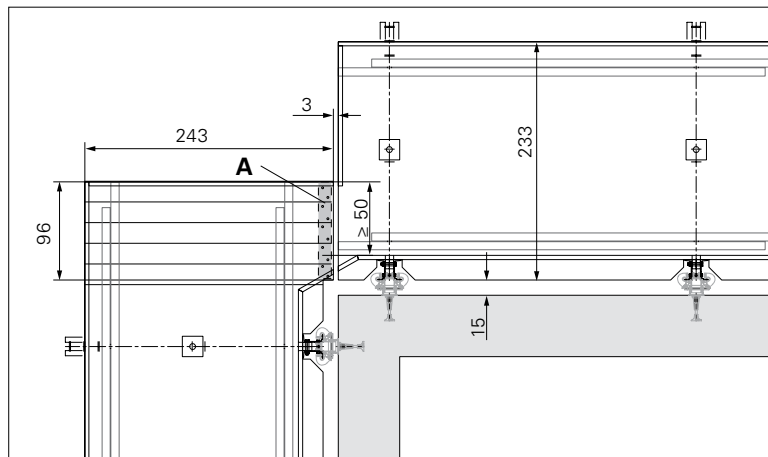

Fig. B3.05

Finishing Platforms

The transition area from one platform to another must be possible to realise without any problems. Do not fall below the passage width of min. 50 cm. Ensure covering for all remaining gaps cannot move out of position.

Mitred intermediate platform

Push girder up to the edge of the platform. Fix cantilevered planking to planks that are positioned laterally to the direction of the planking (**A**). Alternatively for the corner areas, mount laminated wood panel (**B**). Cover the gap between the mitred enclosure elements. (Fig. B3.06)

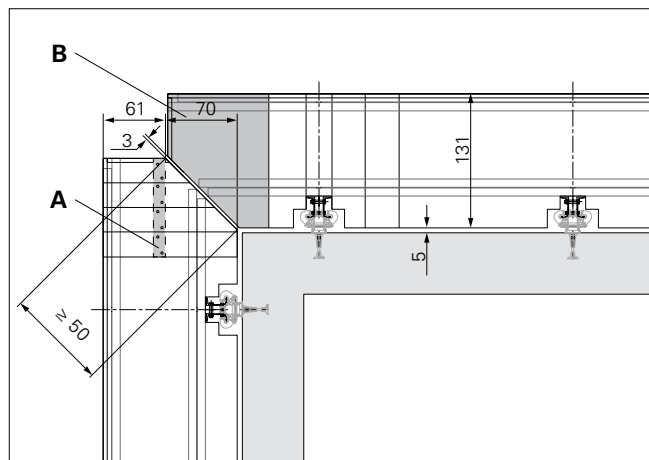

Fig. B3.06

Overlapping intermediate platform

Cover any remaining platform gap. (Fig. B3.07)

Recommended distance to the building 50 mm;
to neighbouring platform 30 mm.

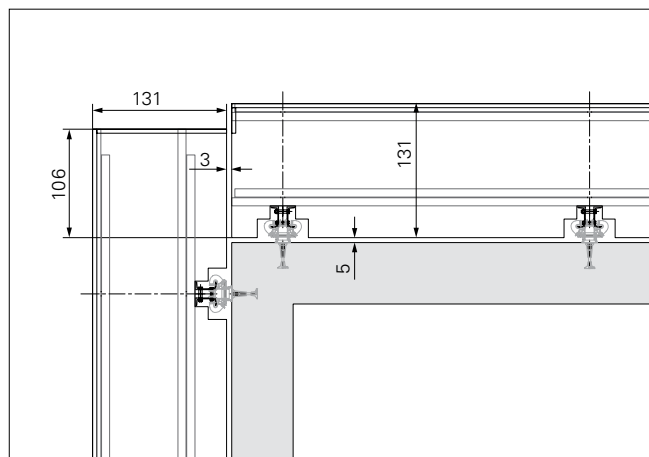

Fig. B3.07

Concreting platform

The transition area from one platform to another must be possible to realise without any problems. Do not fall below the passage width of min. 50 cm.

Mitred concreting platform

Push girder up to the edge of the platform. Fix cantilevered planking to planks that are positioned laterally to the direction of the planking (**A**). Alternatively for the corner areas, mount laminated wood panel (**B**). Cover the gap between the mitred enclosure elements. (Fig. B3.08)

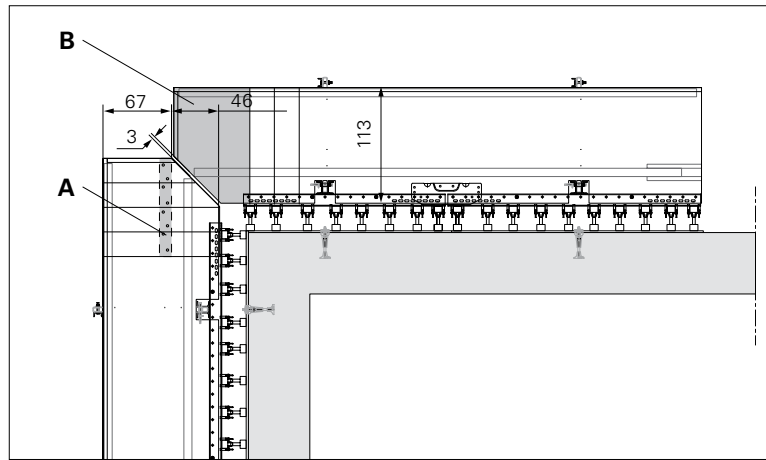

Fig. B3.08

Overlapping concreting platform

Bring platform decking of the overlapping platform in the transition area up to the neighbouring platform. Fix cantilevered planking to timbers (**A**) that are positioned laterally to the direction of the decking. Cover any remaining platform gap. (Fig. B3.09)

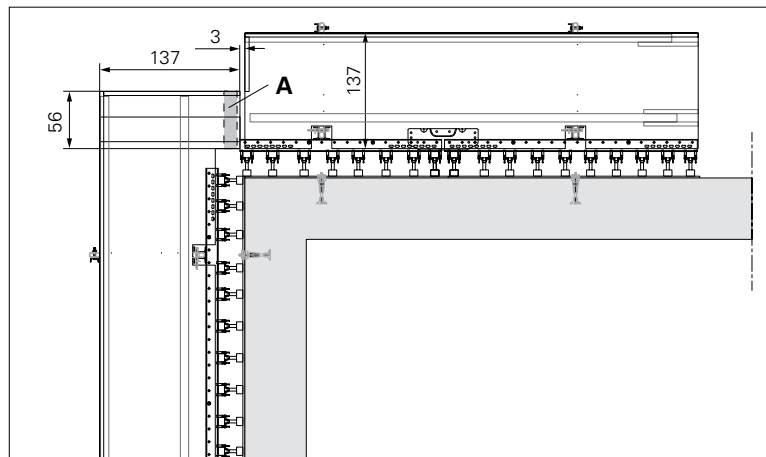

Fig. B3.09

Bracket Arrangement: Parallel

In order to ensure the function of the formwork carriage, arrange the brackets in parallel on rounded structures.

Fix Wall Shoe RCS, hinged (53) to the anchoring (47). Mount the Climbing Shoe (50) on the Wall Shoe hinged.

The Wall Shoe hinged provides compensation for twisting up to $\alpha = 15^\circ$ between the axes of the anchoring and shear frame.



Separate static proof is required for the Wall Shoe and anchoring.

The minimum radius for using the hinged Wall Shoe depending on the anchor spacing c is calculated as follows:

$$R \geq \frac{c}{2 \times \sin(15^\circ)} \approx 2 \times c$$

Recommended distance
to the building 50 mm;
to neighbouring platform 30 mm.

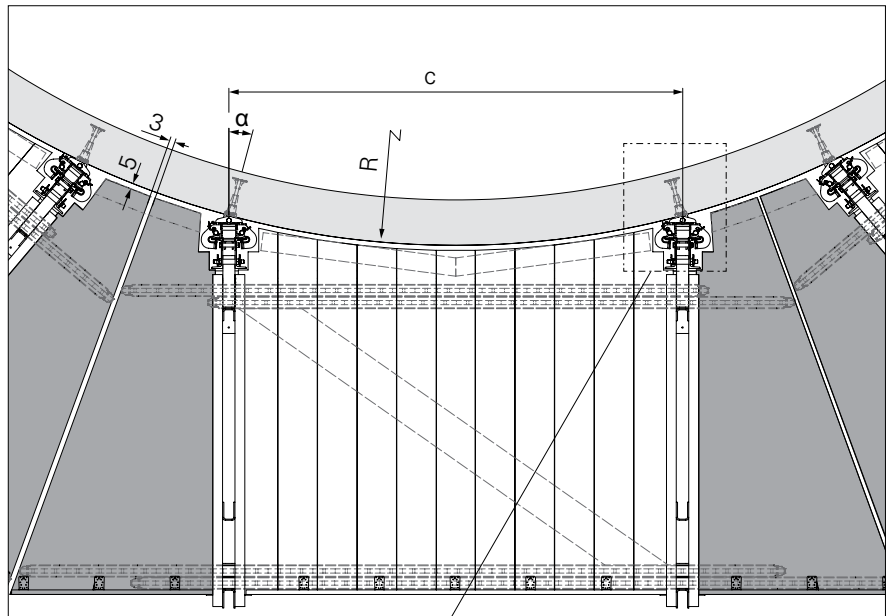

Fig. B4.01

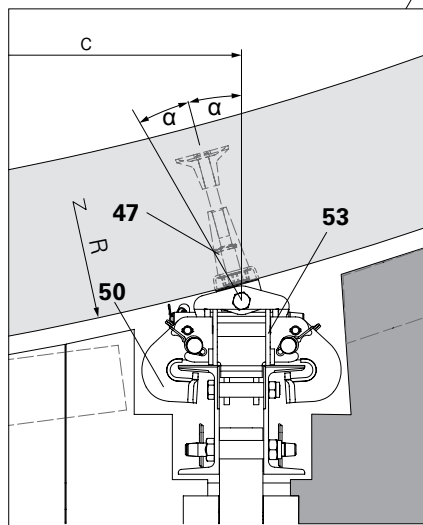

Fig. B4.01a

Bracket Arrangement: Radial

For a radial arrangement of the climbing brackets, the formwork on the carriage cannot be moved backwards.

Therefore, the Wall and Climbing Shoes are mounted between the formwork and working platform after a section has been climbed.

Additional special measures for fixing the girder as well as the bracing with scaffolding tubes are to be implemented.

Recommended distance
to the building 50 mm;
to neighbouring platform 30 mm.

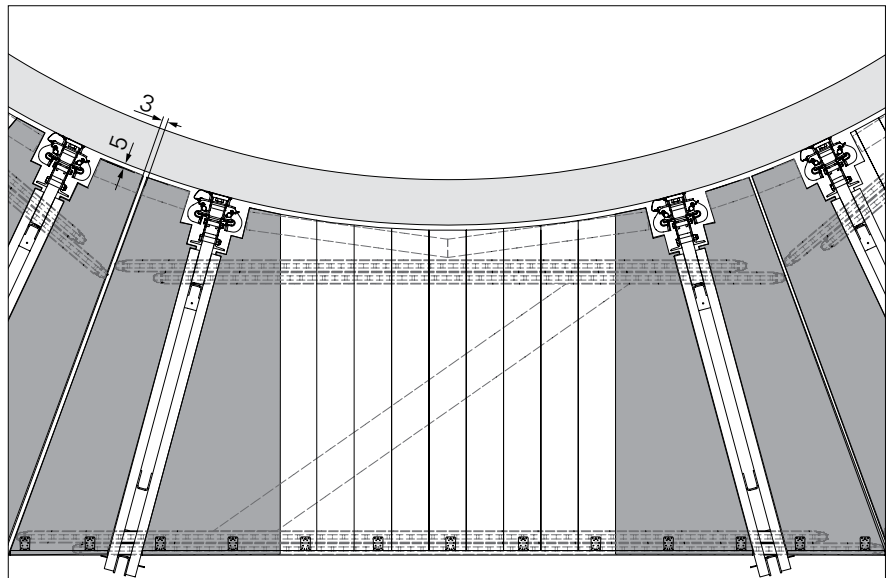

Fig. B4.02

Guardrails

General requirements

Guardrails and safety barriers must be fitted according to valid safety regulations.

Guardrails must be fitted to all leading edges on all platform levels.

High working positions must be secured in order to prevent objects falling to the ground. Mount safety nets or closed protection panel to achieve this. The following can be used as side protection:

- guardrail boards,
- galvanised scaffold tubes \varnothing 48.3 or \varnothing 60.3 made of steel,
- timbers with enclosure made of netting, tarpaulin, plywood or trapezoidal metal sheeting.

(Fig. B5.01)

Guardrails with handrail boards

Requirements:

Handrail boards (**82**) made of Solid Wood C24

Dimensions $d/b = 3/15, 4/12$ or $5/12$ cm or according to the static proof.

Components

79 Guardrail Post U100, 225 RCS

82 Handrail boards

111 F.H. Bolt DIN 603 M8 x 70 MU

1. Fix the handrail boards on the inside to the Guardrail Posts (**79**) at spacings of $a = 50$ cm using F.H. Bolts DIN 603 M8 x 70 MU (**111**).

(Fig. B5.02)

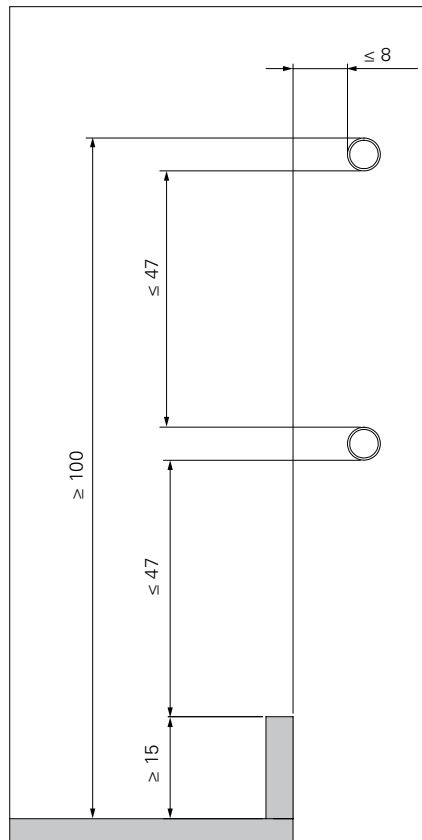

Fig. B5.01

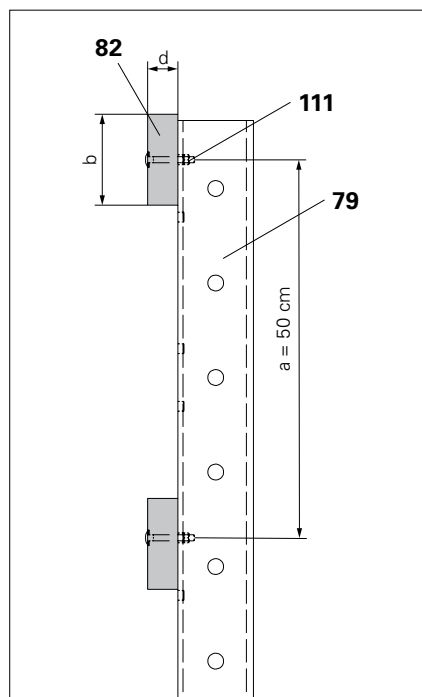

Fig. B5.02

Guardrails with Scaffold Tubes

Requirements:

Steel Scaffold Tubes,
minimum quality S235.
Dimensions $\varnothing \times t = 48.3 \times 3.2$ or
 60.3×4.5 mm

Components

- 79** Guardrail Post U100, 225 RCS
- 88** Steel Scaffold Tube $\varnothing 48.3 \times 3.2$
- 89** Clamp A64 DIN 3570
- 89.1** Hex. Nut ISO 4032 M12-8

1. Insert scaffold tubes in Clamp A64 DIN 3570 (**89**) and fix on the inner side to, e.g. Guardrail Posts, with Hex. Nut ISO 4032 M12-8 (**89.1**). (Fig. B5.03)

Scaffold tubes at the ends or in the middle of the bay are to be connected to each other using vertical scaffold tubes or are supported. This will prevent any overloading.

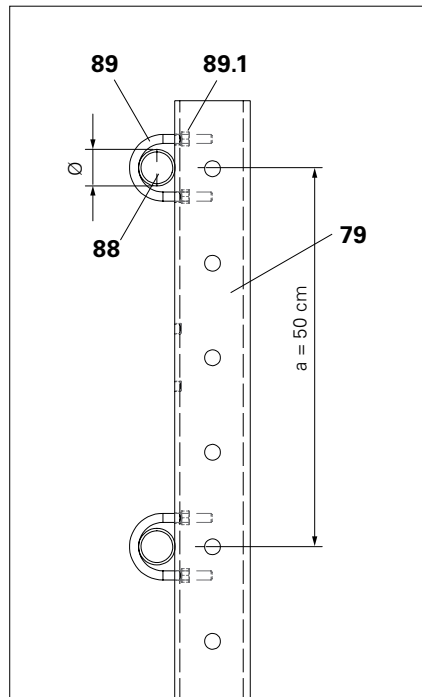

Fig. B5.03

Mounting the safety net

1. Secure the safety net according to manufacturer's instructions.
2. Bring bottom edge of the safety net to the building.
3. Ensure there is sufficient overlapping with other enclosure parts.



Mesh size for enclosure nets ≤ 20 mm.
Scaffold tube spacing $a = 50$ cm.

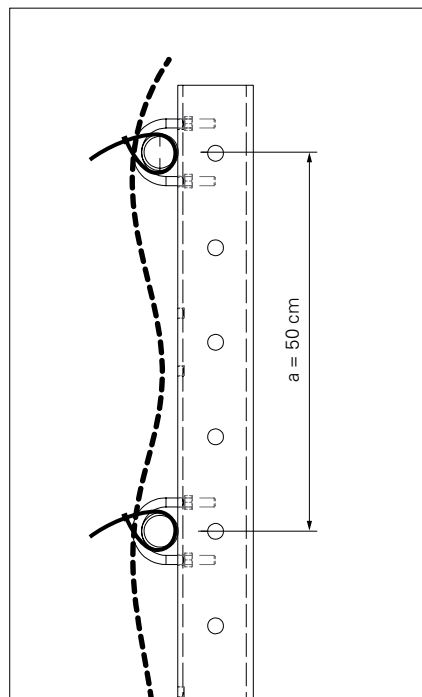

Fig. B5.03

Lateral Guardrails



- Lateral side protection is required to be installed on all end platforms without adjacent platforms.
- For alternative fixing possibilities: see PI Sheet 375.
- The length of the guardrails and toeboards must correspond to the width of the platforms.
- If the girders are only slightly moved to each other, secure the Guardrail Post Holder Multi (**94**) before installing the girder. Otherwise screw and bolt holes can be covered. (Fig. B5.04a)

Components

- 15** Fitting Pin \varnothing 21 x 120
- 16** Cotter Pin 4/1
- 77** Toeboard 30 x 150 mm
- 90** Guardrail Post SCS 150
- 94** Guardrail Post Holder Multi
- 109** F.H. Bolt DIN 603 MB x 45 MU
- 120** Washer ISO 7094 200 HV, A8
- 126** TSS-Torx 6 x 60

Assembly

1. Fix the Guardrail Post Holder Multi (**94**) to the girder (**75**) using 12x TSS Torx 6 x 60 (**126**).
 2. Mount the Guardrail Post SCS 150 (**90**) using 2x fitting pins \varnothing 21 x 120 (**125**) and cotter pins 4/1 (**16**).
 3. Mount Guardrails: see following section.
 4. Fix Toeboard (**77**) to the Guardrail Post Holder Multi (**94**):
 - Pre-drill (\varnothing 9 mm) Toeboard.
 - Fix Toeboard using F.H. Bolt DIN 603 M8 x 45 MU (**109**) and washer ISO 7094 200 HV, A8 (**120**).
- (Fig. B5.04)

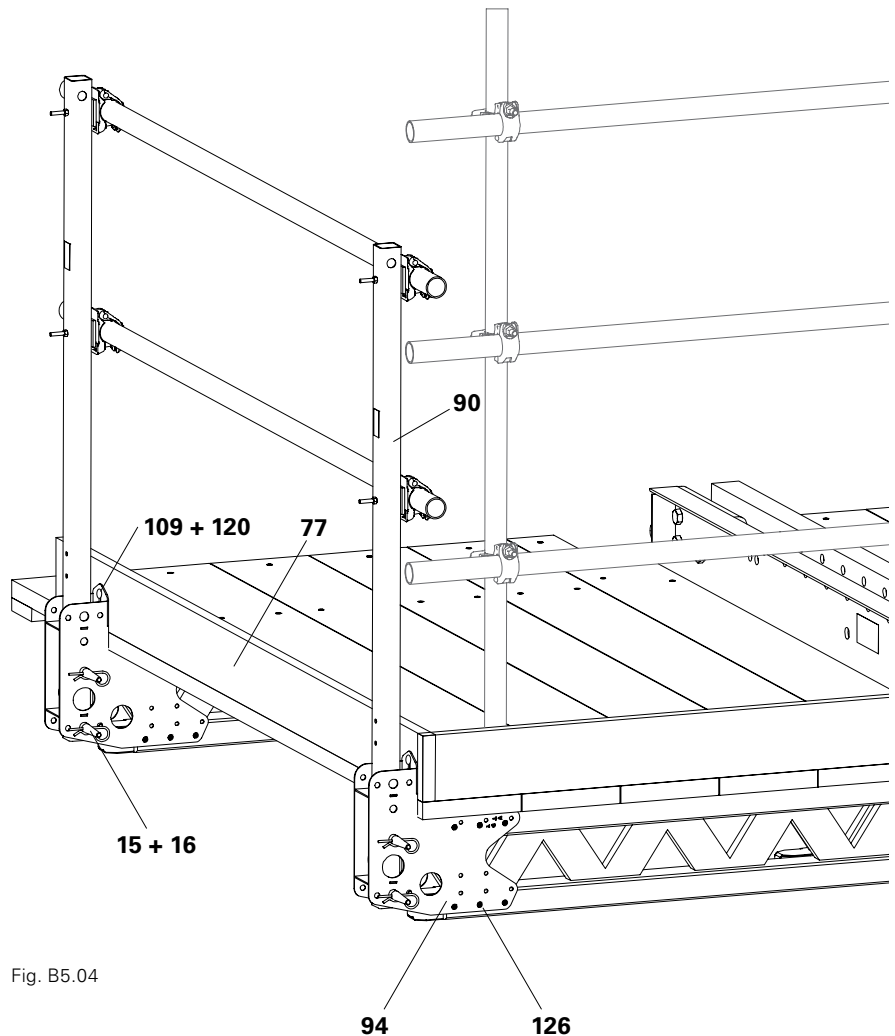

Fig. B5.04

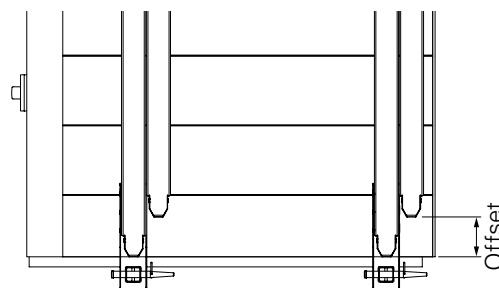

Fig. B5.04a

Mounting the Handrail Boards

Components

- 82** Handrail Board
- 90** Guardrail Post SCS 150
- 110** F.H. Bolt DIN 603 M8 x 100 MU

Assembly

1. Position the Handrail Board (**82**)
L x 12 x 4 cm on the Guardrail Post SCS 150 (**90**).
 2. Pre-drill Handrail Board (Ø 9 mm).
 3. Fix Handrail Board to the Guardrail Post SCS 150 (**90**) using F.H. Bolt M8 x 100 MU (**110**).
- (Fig. B5.05)

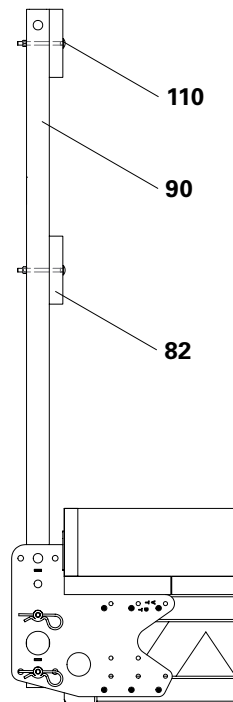

Fig. B5.05

Mounting the Scaffold Tubes

Components

- 88** Scaffold Tube Steel Ø 48.3 x 3.2, Special Length
- 90** Guardrail Post SCS 150
- 93** Guardrail Connector CB
- 110** F.H. Bolt DIN 603 M8 x 100 MU
- 120** Washer ISO 7094 200 HV, A8

Assembly

1. Attach Guardrail Connector CB (**93**) to the Guardrail Post SCS 150 (**90**) using F.H. Bolt DIN 603 M8 x 100 MU (**110**) and washer ISO 7094 200 HV, A8 (**120**).
2. Position Scaffold Tube Steel (**88**) and secure. (Fig. B5.06)

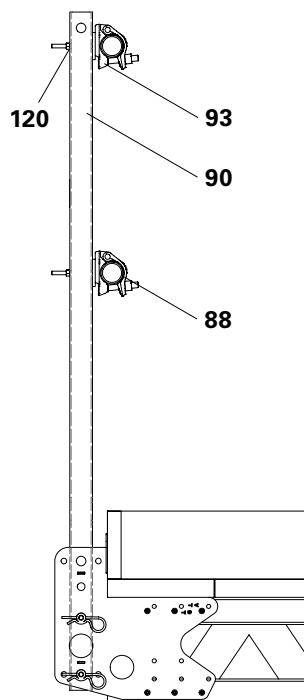

Fig. B5.06

Continuous lateral guardrails with handrail boards

Components

75	Girder GT 24, e.g. 450
76	Planking
82	Handrail Boards
84	L-Angle RCS 120 x 120 x 200
98.1	Timber 10/12
102	Bolt ISO 4017 M12 x 140-8.8
107	Bolt ISO 4014 M20 x 150-8.8
115	Nut ISO 7040 M20-8
118	Nut ISO 7040 M12-8
122	Washer ISO 7094 A12 100 HV
123	Washer ISO 7094 A20 100 HV
125	TSS-Torx 6 x 80



Not suitable as a supporting structure for enclosures!
Mount at least 2x L-Angles per platform side.

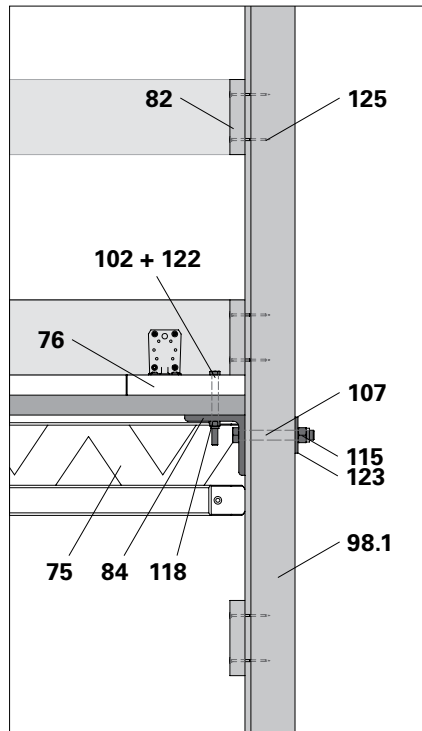

Fig. B5.07

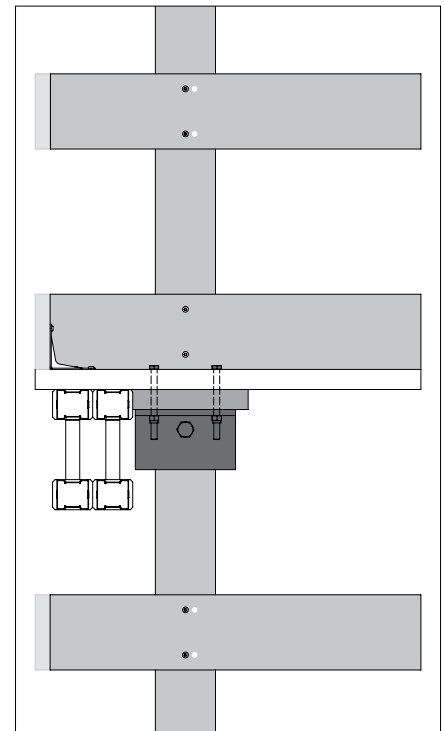

Fig. B5.07a

1. For transferring force under the L-Angle (**84**), screw on planking (**76a**) transversely to the direction of the decking (**76**).
 2. Fix lateral planking to timber planking as well as the planking on girders (**75**) by means of Torx Screws 6 x 80 (**125**).
 3. Pre-drill (Ø 13 mm) lateral planking and planking.
 4. Fix L-Angle (**84**) to lateral planking and planking using 2x hex. bolts M12 x 140 (**102**), large washers (**122**) and nuts (**118**).
 5. Pre-drill (Ø 22 mm) Timber 10/12 and fix to the L-Angle using hex. bolts M20 x 150 (**107**), large washers (**123**) and nuts (**115**).
 6. Fix handrail boards (**82**) to the vertical timber using Torx 6 x 80 (**125**).
 7. Mount Toeboard: see Section "Toeboards" on page 38.
- (Fig. B5.07 – B5.07b)

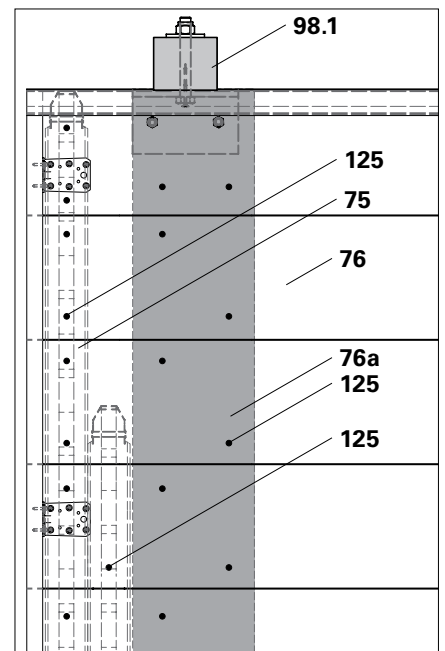

Fig. B5.07b

Continuous lateral guardrails with scaffold tubes

Components

- 75** Girder GT 24, e.g. 450
- 76** Planking
- 84** L-Angle RCS 120 x 120 x 200
- 88** Steel Scaffold Tube Ø 48.3 x 3.2
- 95** Standard Coupler RA 48/48
- 96** Screw-On Coupling-2 HT 8 D48-20
- 102** Bolt ISO 4017 M12 x 140-8.8
- 118** Nut ISO 7040 M12-8
- 122** Washer ISO 7094 12-100 HV
- 125** TSS-Torx 6 x 80



Not suitable as a supporting structure for enclosures.
Mount at least 2x L-Angles per platform side.

1. For transferring force under the L-Angle (**84**), screw on planking (**76a**) transversely to the direction of the decking (**76**).
2. Fix lateral planking to timber planking as well as the planking on girders (**75**) by means of Torx Screws 6 x 80 (**125**).
3. Pre-drill (Ø 13 mm) lateral planking and planking.
4. Fix L-Angle (**84**) to lateral planking and planking using 2x hex. bolts M12 x 140 (**102**), large washers (**122**) and nuts (**118**).
5. Fix the vertical Scaffold Tube Ø 48 (**88**) to the L-Angle using Screw-On Coupling AK 48 (**96**).
6. Fix the horizontal Scaffold Tube Ø 48 (**88a**) to the vertical Scaffold Tube using Standard Couplers RA 48/48 (**95**).
7. Mount Toeboard: see Section "Toeboards" on page 38.
(Fig. B5.08 - B5.08b)

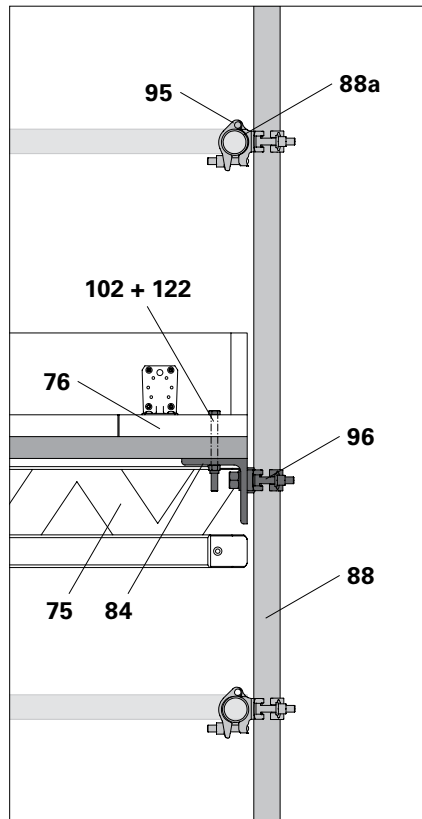

Fig. B5.08

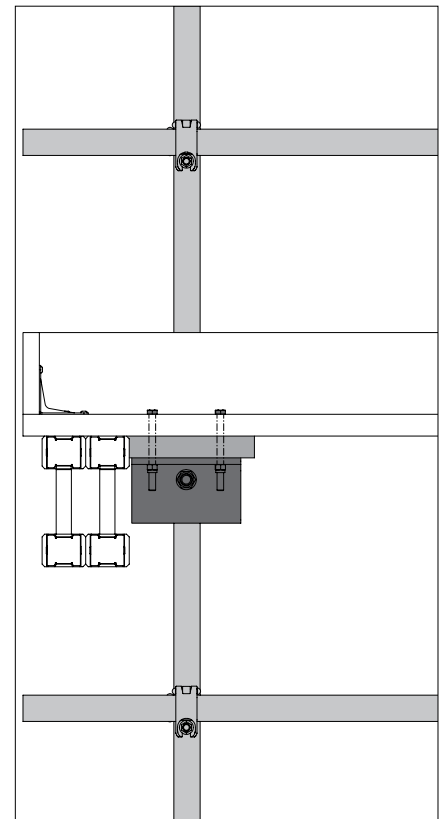

Fig. B5.08a

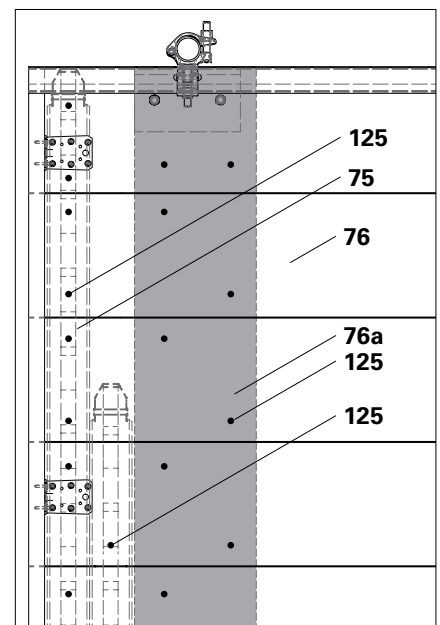

Fig. B5.08b

Position of the Leading Anchor in the Ground Plan

VARIO:

Maintain a distance of at least 3 cm between the Leading Anchor axis and the adjacent formwork girders so that the Leading Anchor (**42**) can be mounted together with the Advancing Bolt (**42.1**). (Fig. B6.01)

TRIO:

Maintain a distance of at least 3 cm horizontally and 4 cm vertically between the Leading Anchor axis and the struts of the formwork so that the Leading Anchor can be mounted together with the Advancing Bolt.

If the anchor position falls on the struts (**41.1**) or girder, then mount the Leading Anchor together with the Anchor Positioning Stud. Nail the Anchor Positioning Stud M30 (**42.2**) to the formlining using wire nails 3.0 x 80. (Fig. B6.02)

Components

42	Leading Anchor
42.1	Advancing Bolt
42.2	Anchor Positioning Stud M30
42.3	Anchor Positioning Plate M30
143	Wire Nail 3 x 80

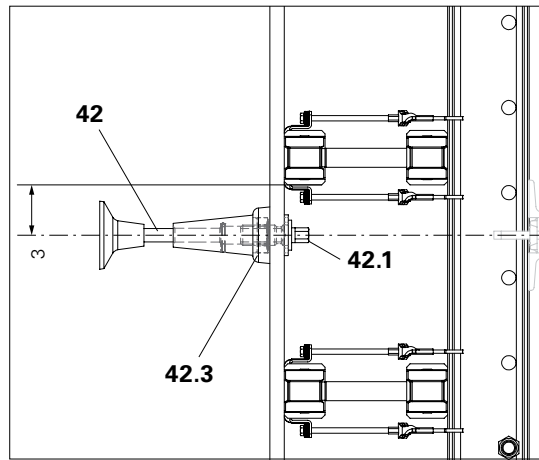

Fig. B6.01

Top view

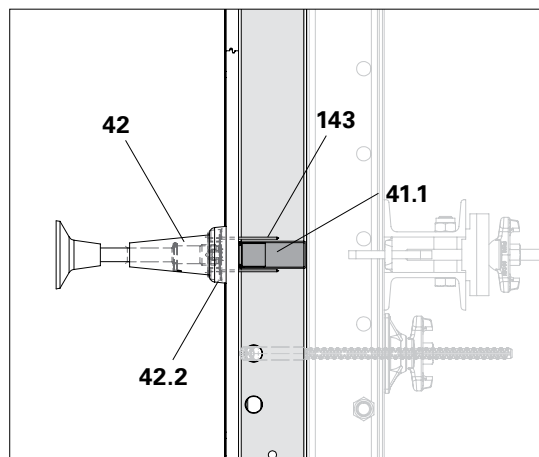

Fig. B6.02

Top view

Planning the Climbing Sequence



Observe the following points for planning and the work instructions for the climbing sequence:

- Realise the intermediate platforms, in particular in the corner areas, to ensure that the hydraulic pump can be transported from one climbing unit to the next without any problems. For this, make sure the transition areas are sufficiently wide and without steps.
- Especially on the corner and internal platforms, the decking is to be installed so that it does not collide with the platforms or formwork of adjacent climbing units during the climbing procedure.
- Access means and ladders are planned to ensure that there is secure access to all climbing units at all times.
- The climbing sequence must be planned around the complete structure. Determine suitable installation of the hydraulic hoses and the climbing of the last climbing unit accordingly.
- Create a hydraulic plan for connecting the climbing device with the hydraulic hoses to the hydraulic pump.
- Appropriate measures are to be determined regarding cordoning off or securing the resulting leading edges.

Attachment Point for the Crane

The size of the climbing units can be limited by the permissible load of the attachment point. For this, the weight of the relevant elements is to be determined during the planning phase.

As a rule, attach the climbing unit to the Climbing Rail RCS.

When assembling and dismantling the climbing units that are to be used with the self-climbing device, the permissible load of the attachment points must also be observed.

The weight of the climbing units is to be specified in the general arrangement drawings.

Standard case: climbing

Permissible total weight of the climbing unit

- when attached to the Climbing Rail with 2x Crane Eye BR-2 2.5 t (**8**), total max. 5 t,
- when attached directly to the spacers in the Climbing Rails 2 x 5t, total max. 10 t (Fig. B6.03)

Moving

Attaching to the Strongback: see the next section.

Assembly/dismantling

Attach assembly units according to the following assembly and pre-assembly instructions.

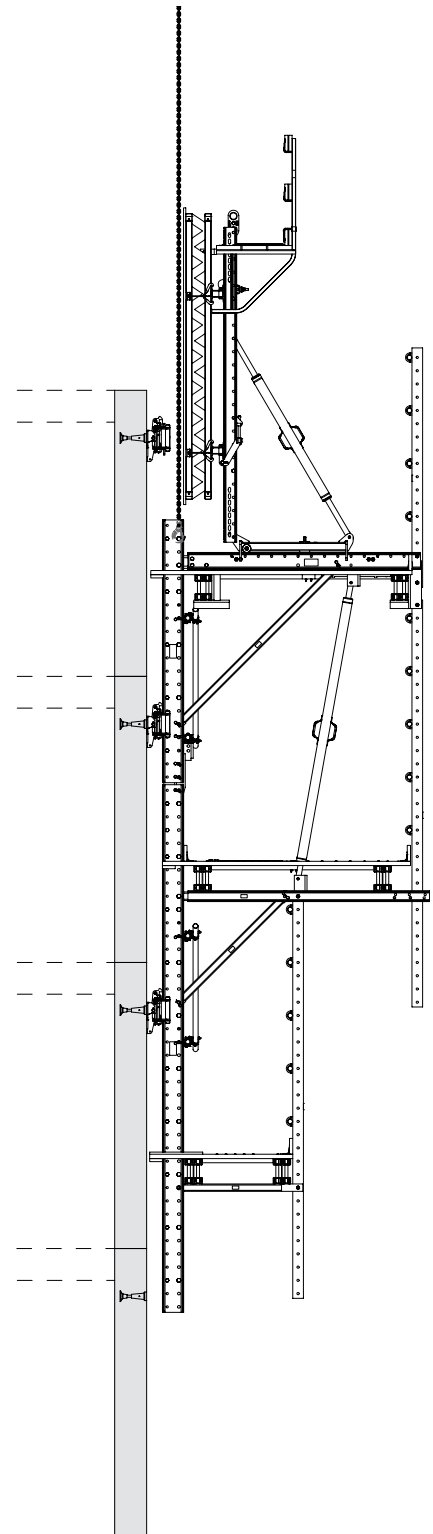

Fig. B6.03

Moving procedure with the Lifting Beam RCS 9 t



- Always lift and move the climbing units with the Lifting Beam RCS 9 t (10).
- For safe attachment and removal of the crane hook, provide suitable measures to prevent falls.
- Follow Instructions for Use for the Lifting Beam 9 t and Crane Eye BR-2 2.5 t (not shown)!
- Ensure loads are evenly balanced when being picked up.

Components

- 4 Spacer M24-82
- 10 Lifting Beam 9 t
- 25 Steel Waler Universal SRU

Attachment point:

Mount the Spacer (4) in the top hole of the Strongback (25).
Load-bearing capacity 5,000 kg

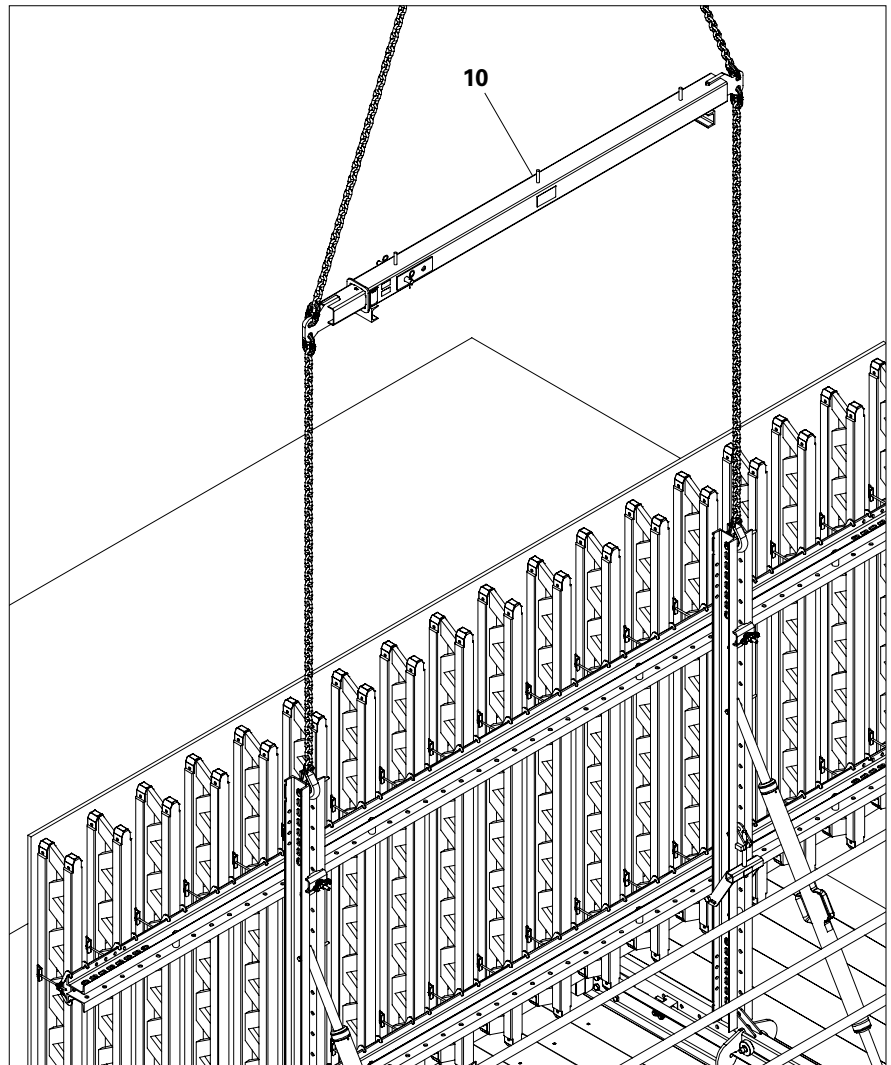

Fig. B6.04

Concreting platform not shown

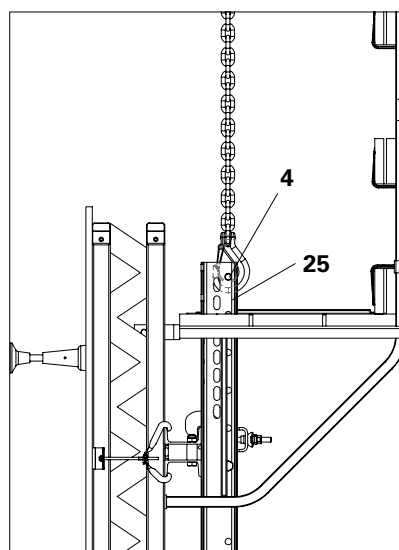

Fig. B6.05

Mounting the Strongback on TRIO Formwork

Components

- 15** Fitting Pin \varnothing 21 x 120
- 16** Cotter Pin 4/1
- 25** Steel Waler Universal SRU L = 2.72
- 26** Waler Fixation SRU
- 27** Adjusting Unit SRU
- 32** Waling
- 35** Strongback Adapter RCS/SRU
- 41** TRIO Panel
- 139** Wingnut Pivot Plate DW 15
- 141** Hook Tie DW 15/400

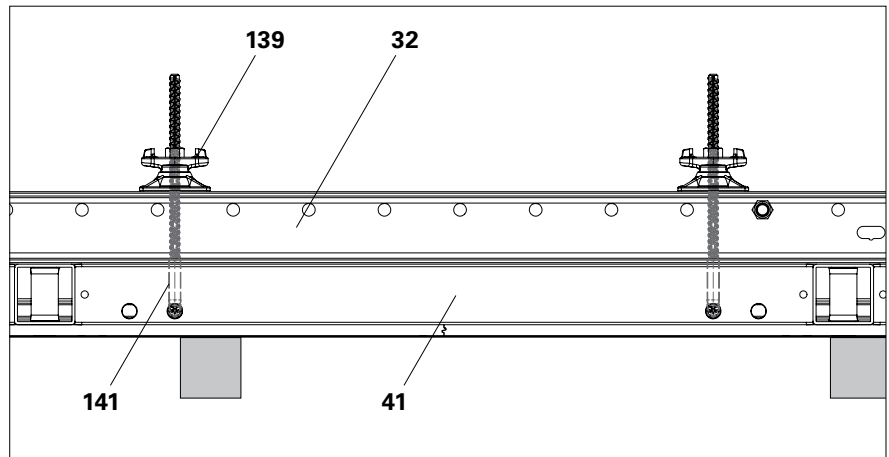

Fig. C1.01

1. Clamp the waling (**32**) using the Hook Tie DW 15 (**141**) and Wingnut Pivot Plate DW 15 (**139**) to the specified position of the TRIO panel (**41**). (Fig. C1.01)



- Use at least 2 Hook Ties DW 15 (left and right) close to the Strongback. The hooks point upwards. (Fig. C1.01a)
- A minimum of 8 Hook Ties are required per climbing unit.
- The waling must project at least 5 cm over the Wingnut Pivot Plate.

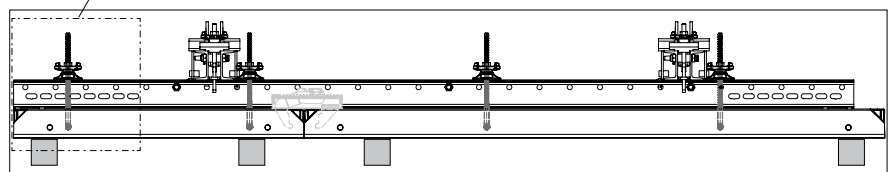
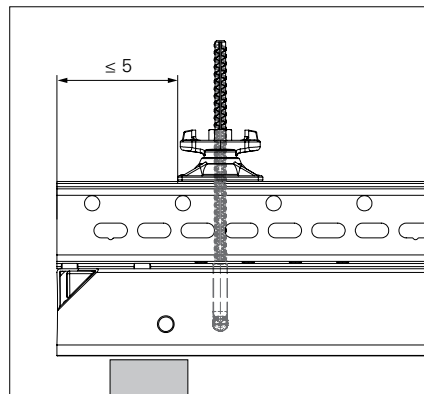

Fig. C1.01a

2. Position the Strongback SRU (25) on the waling (32) according to the planning.
3. Clamp the Strongback to the waling at the top (32) using the Waler Fixation SRU (26).
- (Fig. C1.01b + C1.01c)
4. Pull the Adjusting Unit SRU external (27.1) over the bottom end of the Strongback.
5. If the Crossbeam Head RCS/VARIO is used: mount the Strongback Adapter (35) to the Strongback using fitting pins \varnothing 21 (15) and cotter pins 4/1 (16).
6. Position the top part of the Adjusting Unit (27.1) and mount in the Strongback using fitting pins \varnothing 21 (15a) and cotter pins 4/1 (16a).
7. Spindle in the bottom part (27.2) of the Adjusting Bolt SW 30 (27.3) until it rests against the waling.
- (Fig. C1.01d)
→ Waling now lies against the cheeks of the Adjusting Unit on both sides.
8. Finely adjust the position of the Strongback.



Maximum formwork weight per Adjusting Unit SRU: 1200 kg.

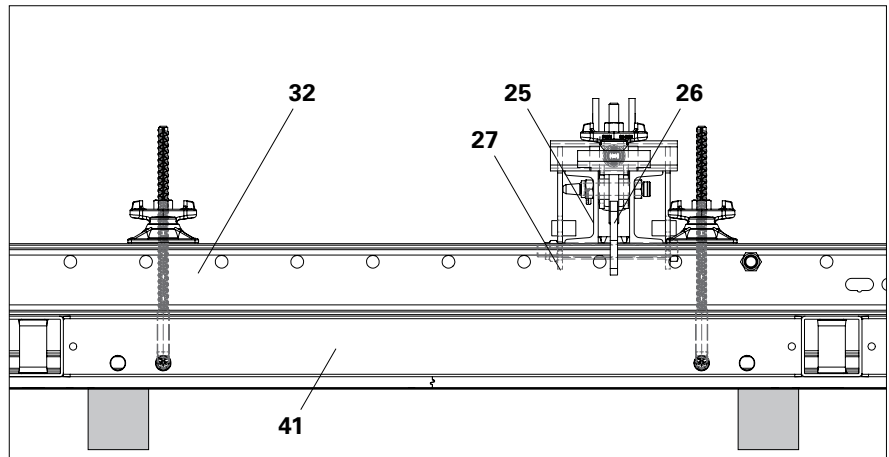

Fig. C1.01b

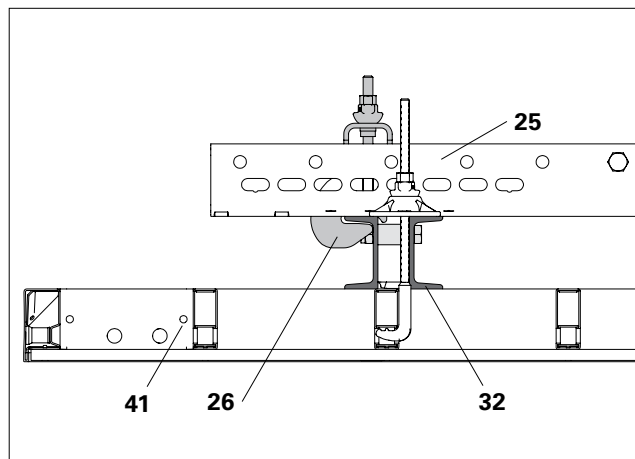

Fig. C1.01c

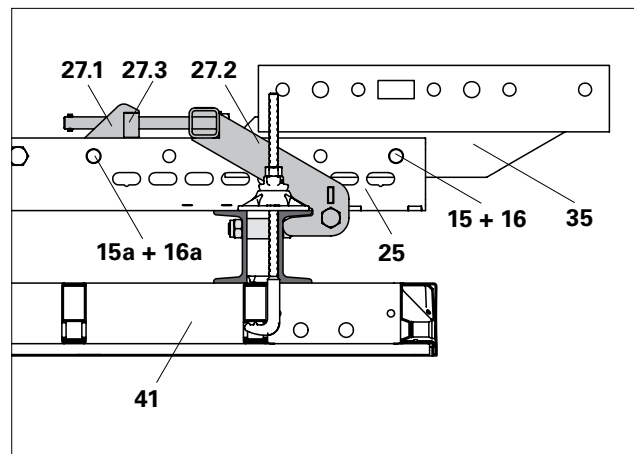

Fig. C1.01d



Strongback Adapter RCS/SRU facilitates the assembly of TRIO formwork elements on the Crossbeam Unit RCS 220 VARIO.

Assembling the Strongback with the Formwork Waler 150 CB



For static reasons, the U-Profile of the Formwork Waler 150 CB must be pointing upwards when using Push-Pull Prop Connector CB (Fig. C1.06)

Components

- 25** Steel Waler Universal SRU L = 2.72
- 26** Waler Fixation U100 – U120
- 27** Height Adjustment Unit-2 CB/SCS/RCS
- 140** Formwork Waler 150 CB
- 142** Clamp Adapter MX / TR-SRU alternatively
- 15** Fitting Pin \varnothing 21 x 120
- 16** Cotter Pin 4/1



- Project-specific planning and dimensioning is required!
- The Formwork Waler 150 CB (**110**) is attached to the Clamp Adapter MX / TR-SRU (**142**) as standard by means of the Tie Rod DW 15 (**142.3**) and Wingnut Counterplate DW 15 (**142.4**). (Fig. C1.04a)
- If the Wingnut Counterplate DW 15 (**142.4**) collides with the Strongback the Clamp Adapter MX / TR-SRU (**142**) can be mounted using fitting pins \varnothing 21 x 120 (**15**) and cotter pins 4/1 (**16**).
- Assembly on the Strongback SCS 325 and 550 takes place in the same way.

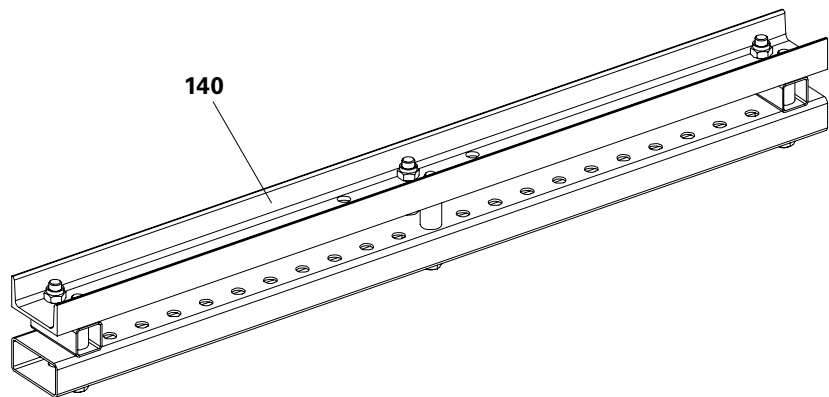

Fig. C1.02

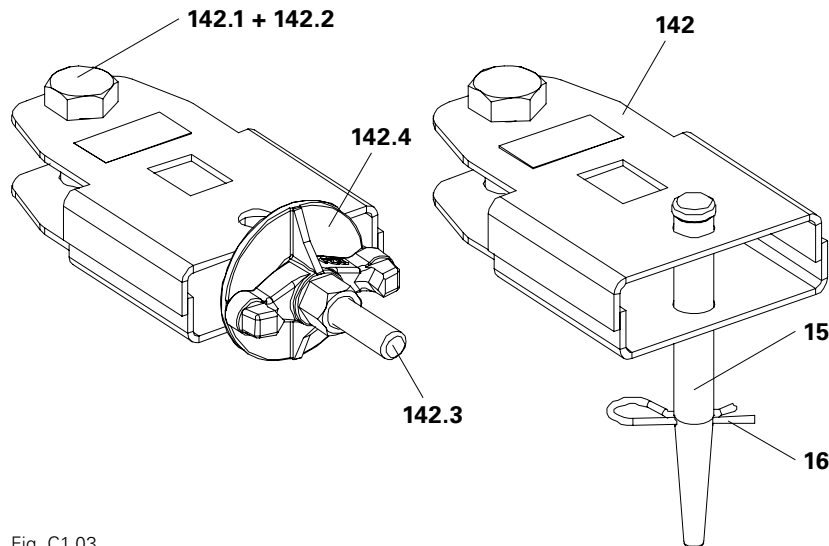

Fig. C1.03

Assembling the Formwork Waler 150 CB on the TRIO Panel

1. Assemble TRIO elements on the assembly area to form formwork units.
2. Fix 2x Clamp Adapter MX / TR-SRU (**142**) to the formwork using bolts ISO 4014 M24 x 80-8.8 (**142.1**) and nuts ISO 4032 M24-8 (**142.2**). (Fig. C1.04)
3. Place the Formwork Waler 150 CB (**110**) with U-profile pointing upwards on the Clamp Adapter MX / TR-SRU (**142**).

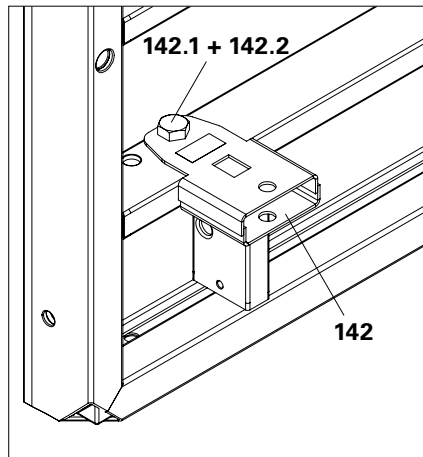

Fig. C1.04

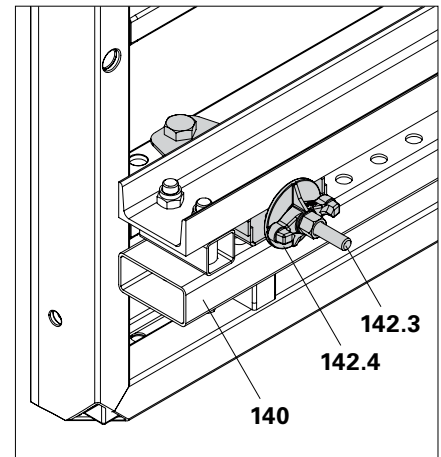

Fig. C1.04a

4. Brace the Formwork Waler 150 CB (**110**) on the formwork using Tie Rod DW 15 (**142.3**) and Wingnut Counterplate DW 15 (**142.4**). (Fig. C1.04a)

Alternatively:

Mount the Formwork Waler 150 CB on the Clamp Adapter MX / TR-SRU using fitting pins $\varnothing 21 \times 120$ (**15**) and cotter pins 4/1 (**16**).

5. Position the Strongback (**25**) on Formwork Waler 150 CB (**110**) according to the bracket spacing. Bottom projecting length: see project-specific planning.
6. Mount Waler Fixation U 100 – U120 (**26**) and secure in position by tightening the Quick Jack Nut. (Fig. C1.05 + C1.05a)

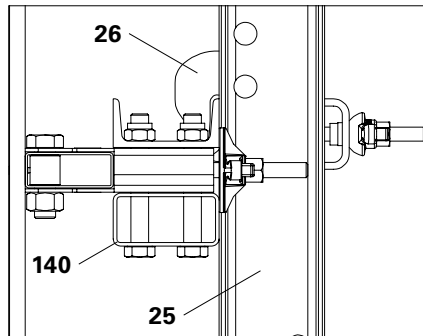

Fig. C1.05

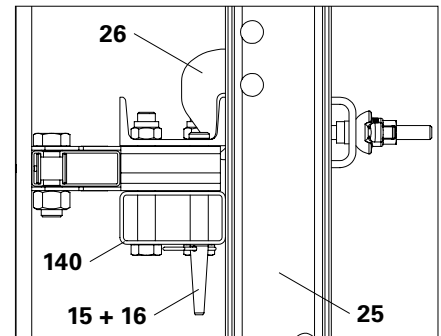

Fig. C1.05a



- Does the U-profile of the Formwork Waler 150 CB point upwards? (Fig. C1.05 + C1.05a)
- Does the Formwork Waler 150 CB rest against the vertical profiles of the formwork?

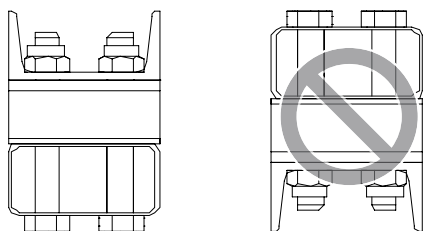

Fig. C1.06

Assembling the Strongback on VARIO Formwork

Components

- 15 Fitting Pin \varnothing 21 x 120
- 16 Cotter Pin 4/1
- 25 Steel Waler Universal SRU
- 26 Waler Fixation SRU
- 27 Adjusting Unit SRU
- 32 Waling

Assembly

Assembly takes place on a horizontal element

1. Position the Strongback on the formwork waling according to the planning instructions.
2. Position the Strongback SRU U120 (25) on the top waling (32) with Waler Fixation SRU (26). (Fig. C1.07a)
3. Pull the Adjusting Unit SRU external (27) over the bottom end of the Strongback.
4. Mount the top part of the Adjusting Unit on the Strongback using fitting pins \varnothing 21 (15) and cotter pins 4/1 (16).
5. Spindle in the bottom part of the Adjusting Bolt SW 30 until it rests against the waling. (Fig. C1.07b)
→ Waling now lies against the cheeks of the Adjusting Unit on both sides.
6. Finely adjust the position of the Strongback.
7. Clamp the Waler Fixation SRU (26).



Maximum formwork weight per Adjusting Unit SRU: 1200 kg

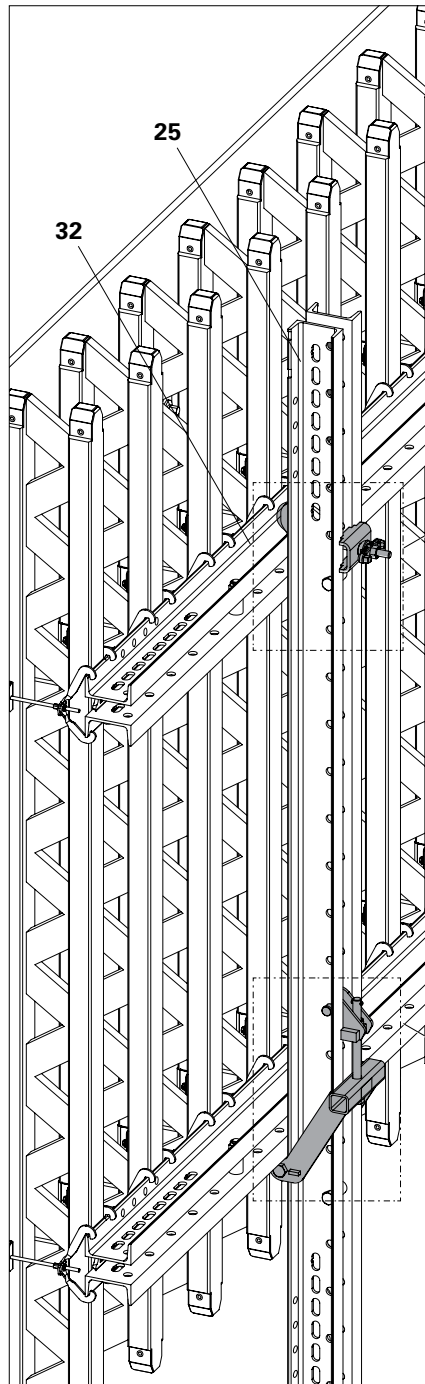

Fig. C1.07

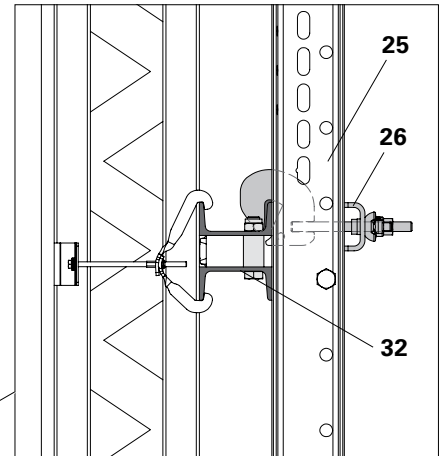

Fig. C1.07a

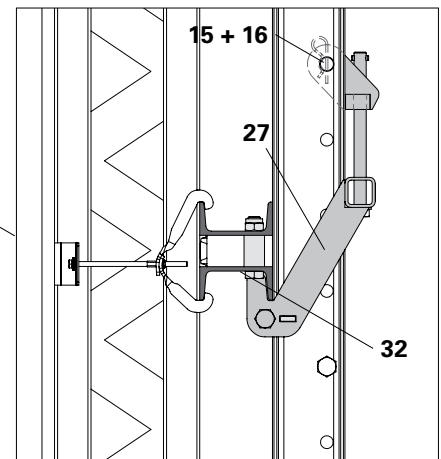

Fig. C1.07b

Concreting Platform

Concreting platform with individual brackets

Mount the concreting platform according to the project-specific planning.

Use the Scaffold Bracket GB 80 for VARIO and Scaffold Bracket TRG 80 for TRIO.

See Instructions for Assembly and Use of the respective formwork system.

1. Attach brackets for the concreting platform to the formwork.
2. Install planking on the brackets. Cut decking (**76**) around the Strongbacks (**25**) and secure to the brackets in order to prevent moving and lifting.

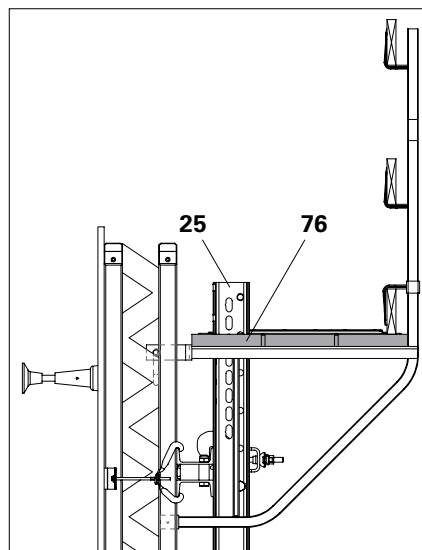

Fig. C1.08

Mounting the Concreting Platforms on the Strongbacks

Components

- 37** Platform Beam RCS/SRU 113
- 75** Girder (here GT 24)
- 76** Planking
- 77** Toeboard
- 80** Guardrail Post RCS/SRU 184
- 88** Steel Scaffold Tube \varnothing 48.3 x 3.2
- 125** TSS Torx 6 x 80
- 137** Hex. Wood Screw 8 x 60 DIN 571

Assembly

Mount the concreting platform according to the project-specific planning. Assembly takes place on a horizontally-positioned element:

1. Fix girder (**75**) to each vertical connection of the Platform Beam RCS/SRU 113 (**37**) by means of 2x wood screws \varnothing 8 x 60 (**137**).
2. Cut planking (**76**) to size. Cut out planking in the area of the Strongback. Fix planking to every girder using 2x TSS Torx 6 x 80 (**125**).
3. Fix Toeboards (**77**) with Angle Brackets to the planking at a distance of approx. 1 m.
See Section "Girders" on Page 35
4. Fix Guardrail Post RCS/SRU (**80**) to the concreting platform using the provided 2x hex. bolts M20 x 100 (**80.1**) and nuts. (Fig. C1.09)
5. Attach the concreting platform on the girders to the crane lifting gear and transport to the formwork. (Fig. C1.10)

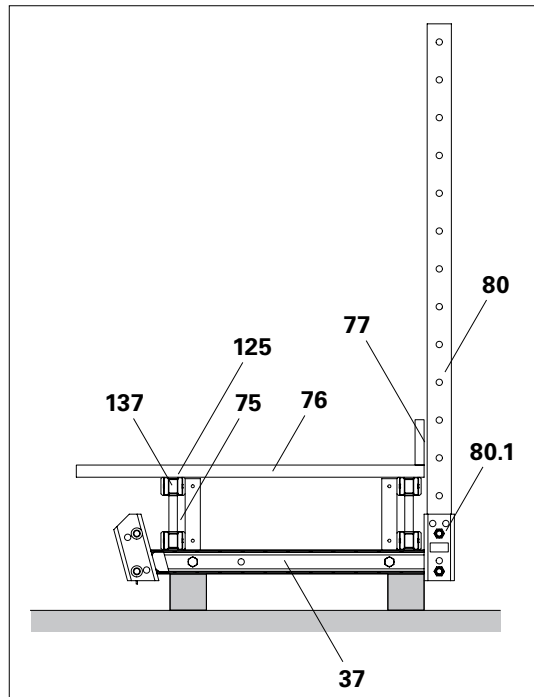

Fig. C1.09

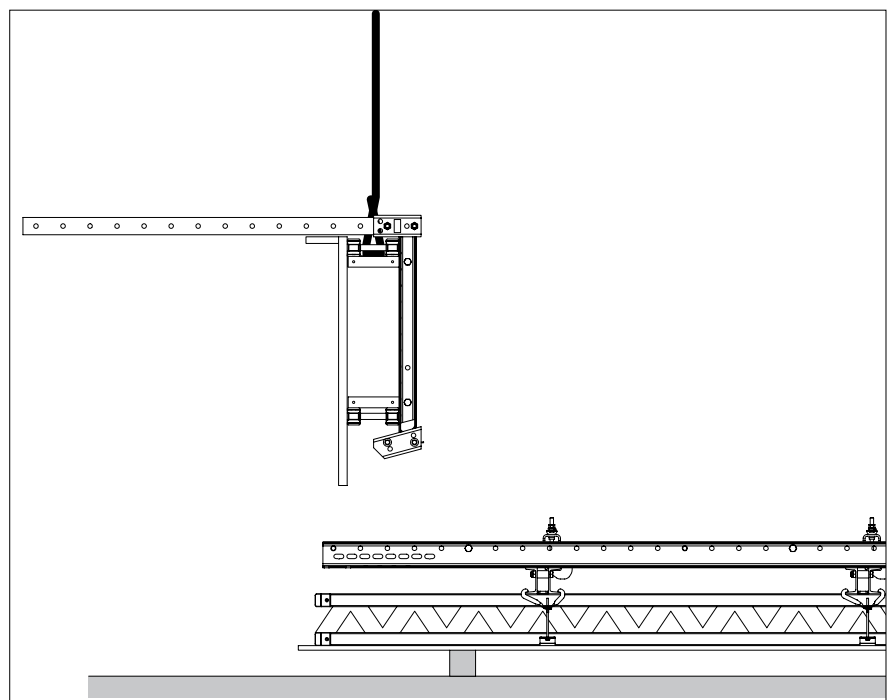

Fig. C1.10

6. Mount the pre-assembled platform to the Strongback (**25**) using the provided 2x fitting pins $\varnothing 21 \times 120$ (**37.1**), washers and cotter pins 5/1.
7. Attach the Strongback to the crane lifting gear and turn the formwork. (Fig. C1.11)
8. Mount scaffold tubes (**88**) or handrail boards on the Guardrail Posts. See Section "Guardrails" on Page 48. (Fig. C1.12)
9. Spray the formlining with a concrete release agent.

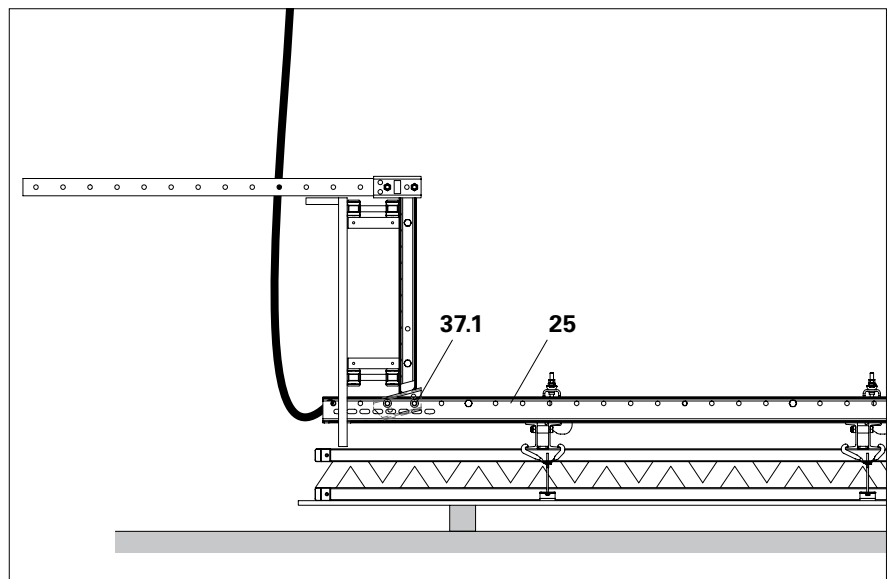

Fig. C1.11

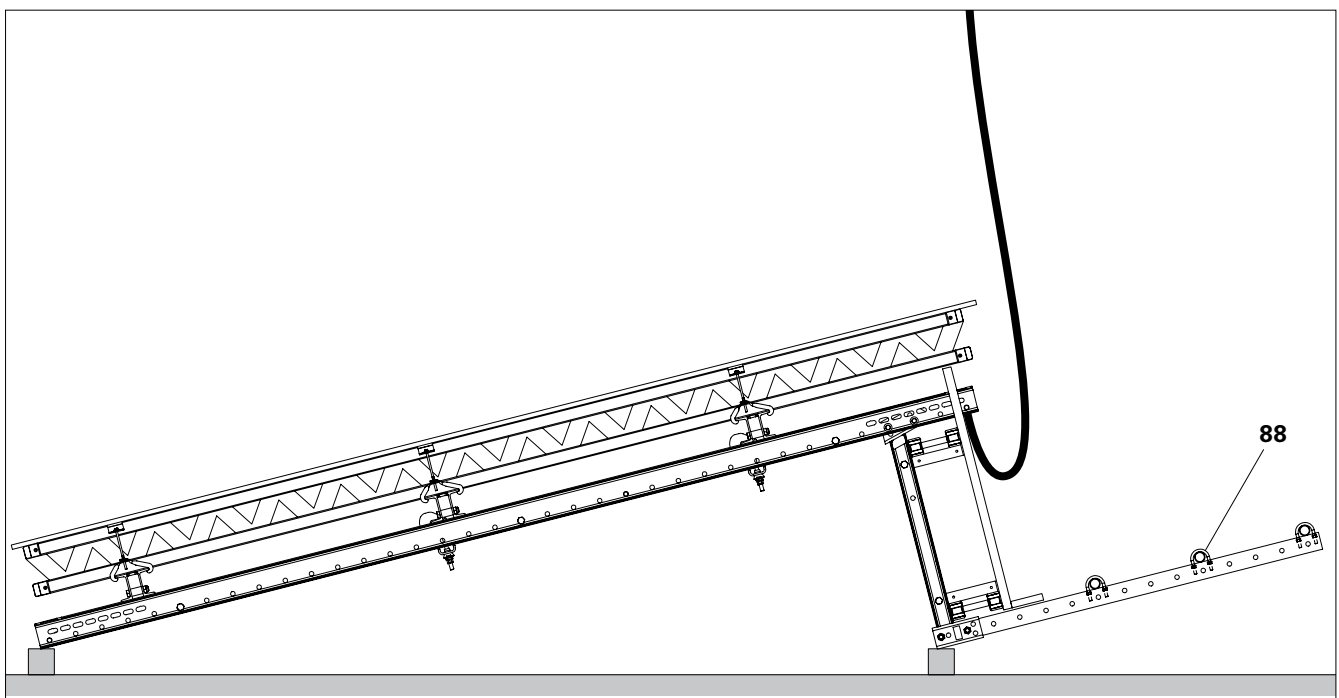

Fig. C1.12

Mounting the intermediate platforms on the Strongbacks

Components

- 37** Platform Beam RCS/SRU 113
- 81** Guardrail Post U100 384 RCS
- 137** Hex. Wood Screw 8 x 60 DIN 571

1. For the intermediate platforms, pre-assemble the Platform Beams RCS/SRU (**37**) in the same way as for the concreting platform.
2. Fix Guardrail Post RCS 384 (**81**) to the concreting and intermediate platforms using the provided 2x hex. bolts M20 x 100 (**81.1**) and nuts.
3. Attach the Strongback to the crane lifting gear and turn the formwork.
4. Mount scaffold tubes or handrail boards on the Guardrail Posts. See Section "Guardrails" on Page 48.
5. Spray the formlining with a concrete release agent.



Assembly of access ladder:
see separate product information.

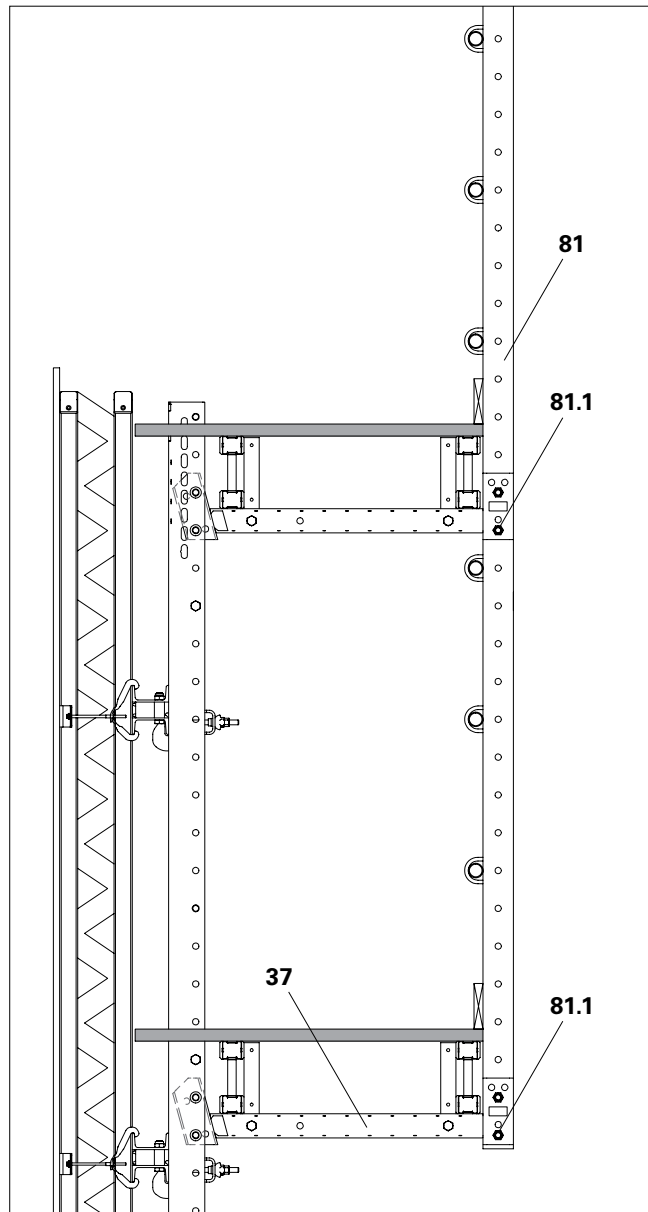

Fig. C1.13

Installation of the Working Platform



- For assembly, a crane or other lifting device as well as a level assembly surface is required.
- Any intermediate status is to be correctly secured by means of temporary supports to prevent any tipping over.
- Aligned and measured stops simplify precise and fast pre-assembly of the brackets.

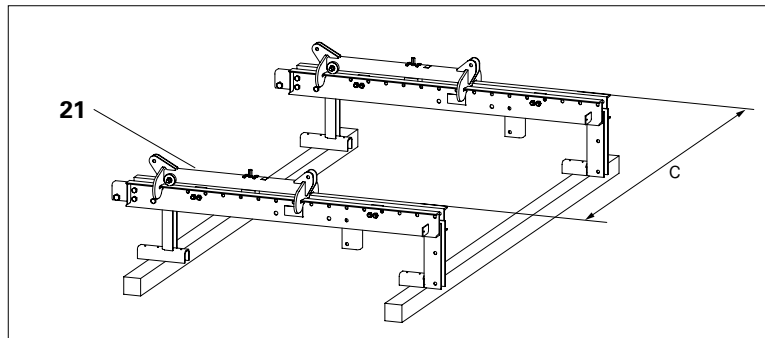

Fig. C2.01

Assembly of the platform

Components

-
- 21** Crossbeam Unit RCS 220 VARIO
 - 22** Crossbeam Head RCS/VARIO
 - 24** Carriage RCS
 - 75** Girder GT 24, e.g. 450
-

Assembly

1. Measure and align Crossbeam Unit (**21**) on timbers in accordance with project-specific bracket spacing (c). (Fig. C2.01)
2. Pre-drill girder, here GT 24 (**75**), according to the drilling plan using $\varnothing 9$ mm. (Fig. C2.02a)
3. Insert the girder in the Crossbeam according to the plan and secure with F.H. Bolts M8, see Section "B2 Planning the Platforms" on page 34. (Fig. C2.02)

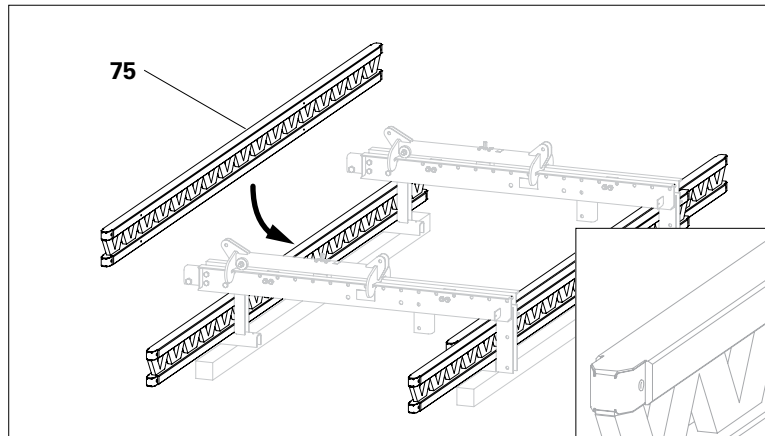

Fig. C2.02

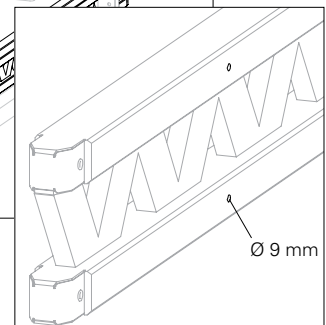

Fig. C2.02a

4. Fix planking diagonal bracing and laminated wood panels to the girders according to the plan, see Section "Planking" on page 38.
5. Mount Toeboards with Angle Brackets, see Section "Toeboards" on page 38.
(Fig. C2.03)

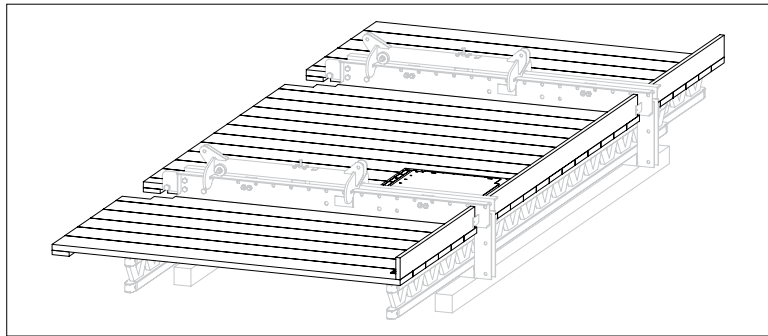

Fig. C2.03

Guardrail Installation

Components

79 Guardrail Post RCS 226

89 Clamp A64 DIN 3570

79.1 Bolt ISO 4014 M20 x 120-8.8

Assembly

1. Fix Guardrail Post RCS 226 (**79**) using the 2x bolts M20 x 120 (**79.1**) and nuts respectively. Use the two top drilled holes. The bottom drilled hole must remain free for mounting the bottom anti-fall protection.
2. Fix Scaffold Tubes \varnothing 48 to the Guardrail Post using Clamp A64 (**89**), see Section "Guardrails" on page 48. (Fig. C2.04)
3. Mount lateral guardrail protection, see Section "Lateral guardrail protection" on page 50.

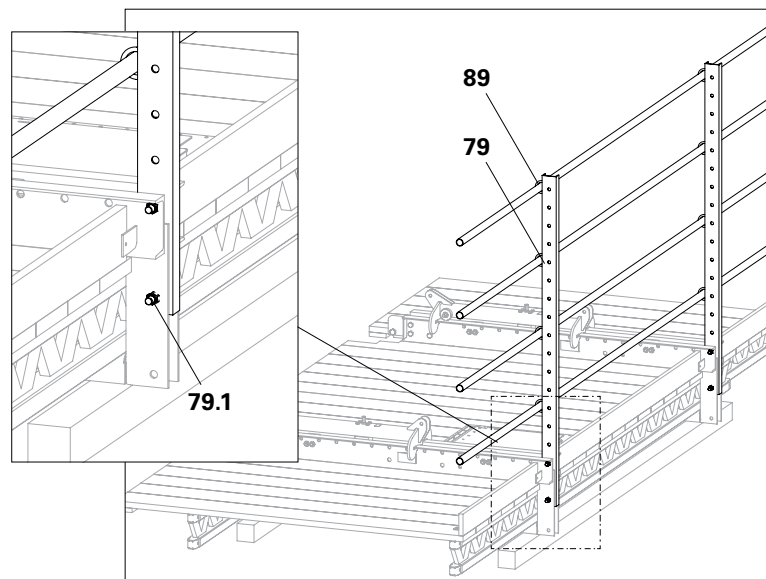

Fig. C2.04

Pre-Assembling the Climbing Rails

Components

- 1** Top Climbing Rail RCS
- 8** Climbing Rail Hinge RCS
- 87** Scaffold Tube Bracing
- 91** Scaffold Tube Connector LPS/RCS
Ø 48
- 97** Swivel Coupler SW 48/48

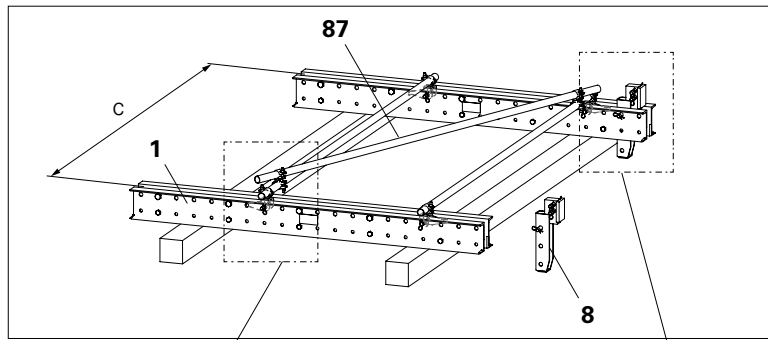
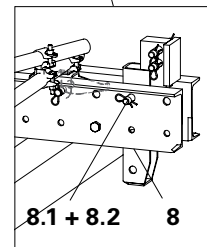
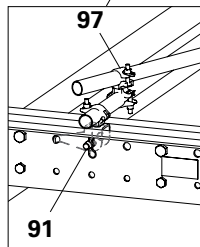

Fig. C2.05



Assembly

1. Position top Climbing Rails (**1**) on timbers and align in accordance with project-specific bracket spacing (*c*).
2. Connect the Climbing Rails to scaffold tubes and scaffold tube holders Ø 48 (**91**).
3. Diagonally connect scaffold tube with swivel couplers (**97**).
4. Mount Climbing Rail Hinge RCS (**8**) in drilled hole Ø 26 mm using the provided fitting pins (**8.1**) and cotter pins (**8.2**). (Fig. C2.05)

General



Warning

- Risk of falling from unsecured building edges!
A fall can result in serious injury or even death.
⇒ Install guardrails.
⇒ Use personal protective equipment to prevent falling from a height (PPE).
- During assembly on the construction site, components may fall to the ground and hit people below!
This could lead to serious injuries or even death.
⇒ Cordon off areas of risk under the working areas.
⇒ Only release the climbing unit from the crane lifting gear when all Climbing Shoes are closed and the climbing unit fully rests on the Climbing Shoes.



- Before attaching the RCS units check the structure to ensure there is sufficient load-bearing capacity.
- The assembly sequence assumes that work is carried out for a short time under a positively-connected load.

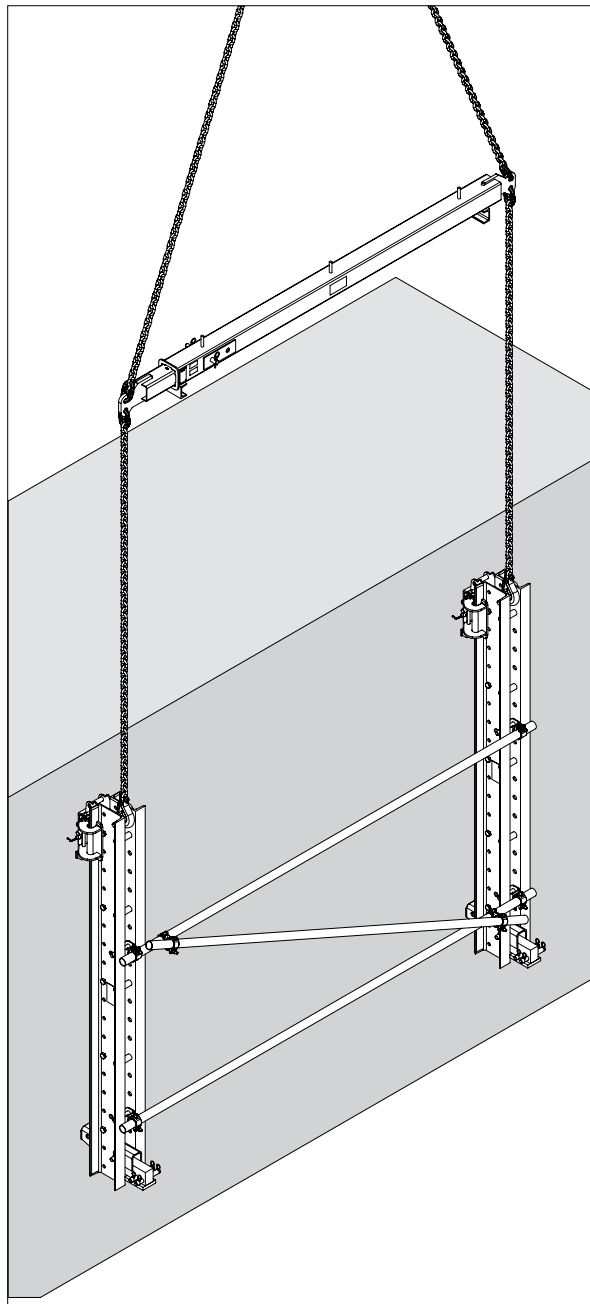

Fig. C3.01

Mounting the Climbing Rail

Components

- 3** Spacer M20-82
- 8** Climbing Rail Hinge RCS
- 10** Lifting Beam 9 t
- 47** Anchoring
- 50** Climbing Shoe RCS
- 51** Wall Shoe RCS

Assembly

1. Mount Wall Shoes RCS (**51**) on the embedded anchoring (**47**).
 2. Mount Climbing Shoes RCS (**50**) on Wall Shoes using the corresponding locking pins.
 3. Activate the climbing pawls.
 4. Attach Climbing Rails with Lifting Beam (**10**) to the top Spacer or Crane Eye BR-2 2.5 t.
 5. Insert the Climbing Rails into the Climbing Shoes from below and then lift until above the planned Spacer.
- Alternatively:** insert the Climbing Rails into the open Climbing Shoes and close them with site personnel in a safe position.
6. Place the Climbing Rail using the planned distance (**3**) on the climbing pawl (**50.1**).
 7. Adjust the Climbing Rail Hinge RCS (**8**) to "pressure point" function.
 8. From a safe position, detach the crane lifting gear.
- (Fig. C3.02)

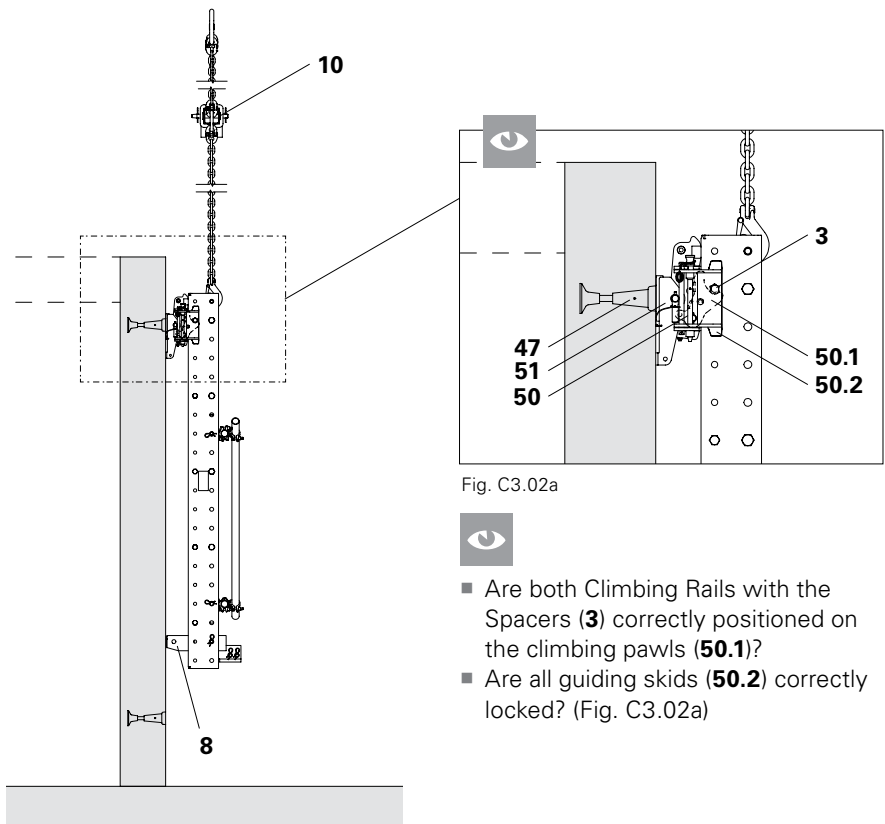

Fig. C3.02a



- Are both Climbing Rails with the Spacers (**3**) correctly positioned on the climbing pawls (**50.1**)?
- Are all guiding skids (**50.2**) correctly locked? (Fig. C3.02a)

Fig. C3.02



- For assembling the Wall and Climbing Shoes, see Section "Assembling the suspension" on page 108.
- For operating the Climbing Shoe, see Section "D5 Operating the Climbing Shoe" on page 112.

Mounting the Working Platform

Components

- 11** Diagonal Strut I = 2121
- 21** Crossbeam Unit RCS 220 VARIO
- 22** Crossbeam Head RCS/VARIO
- 108** Bolt ISO 4014 M24 x 130-8.8

Assembly

1. Move the Carriage over the centre of gravity of the working platform.
2. Attach the working platform to the 4-sling lifting gear on the crane. Crane sling angle $\alpha \leq 30^\circ$. Attachment points: 1x fitting pin $\varnothing 21 \times 120$ with cotter pin 4/1 on Carriage at front and rear respectively.
3. When transporting with the crane, guide the working platform using ropes with site personnel in a safe position.
4. Attach Crossbeam (**21**) with Crossbeam Head RCS/VARIO (**22**) in 4th hole $\varnothing 26$ of the Climbing Rail using bolt M24 x 130-8.8 (**108**). (Fig. C3.03a)
5. Mount Diagonal Struts 2121 using 2x bolts (**11.1**) and 4x cotter pins (**11.2**).
6. Mount project-specific wind bracing.

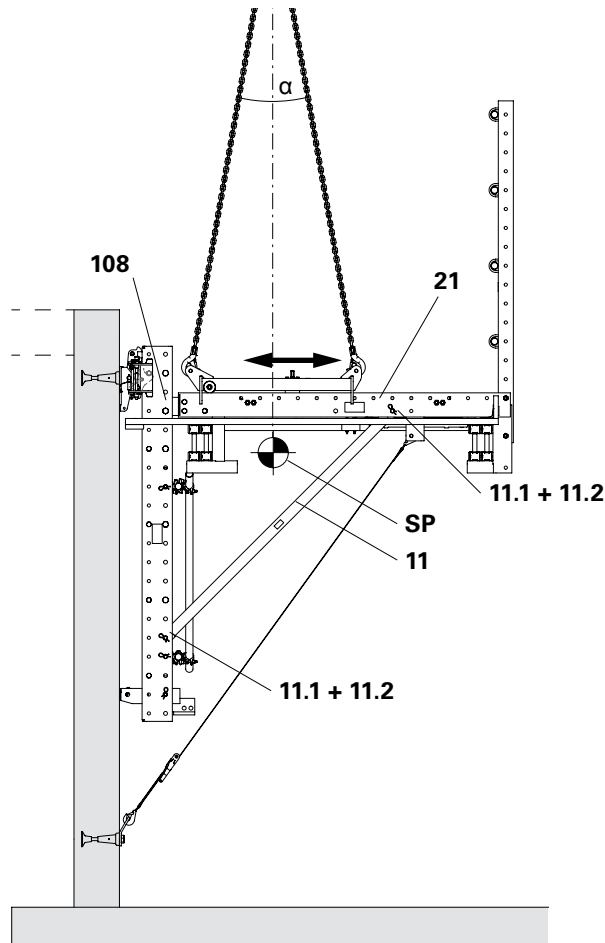

Fig. C3.03



It may be necessary to move the Spacers or to release the adjacent Spacers in the Climbing Rail for the assembly. See Section "Pre-assembling the Climbing Rails" on Page 80.

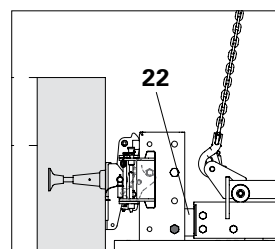

Fig. C3.03a

Mounting the Formwork



Before assembling the formwork, wind bracing must first be mounted.

Components

- 15** Fitting Pin \varnothing 21 x 120
- 16** Cotter Pin 4/1
- 24** Carriage RCS
- 25** Steel Waler Universal SRU L = 2.72
- 28** Heavy-Duty Spindle SLS 200/300
- 47** Anchoring

Assembly

1. Mount the Formwork Spindle (**28**) on the Strongback (**25**) using fitting pins and cotter pins. The assembly position must be determined on a project-specific basis.
2. Attach the pre-assembled formwork elements to the Strongback (**25**).
3. Align the formwork and then move to the bracket unit. (Fig. C3.04)

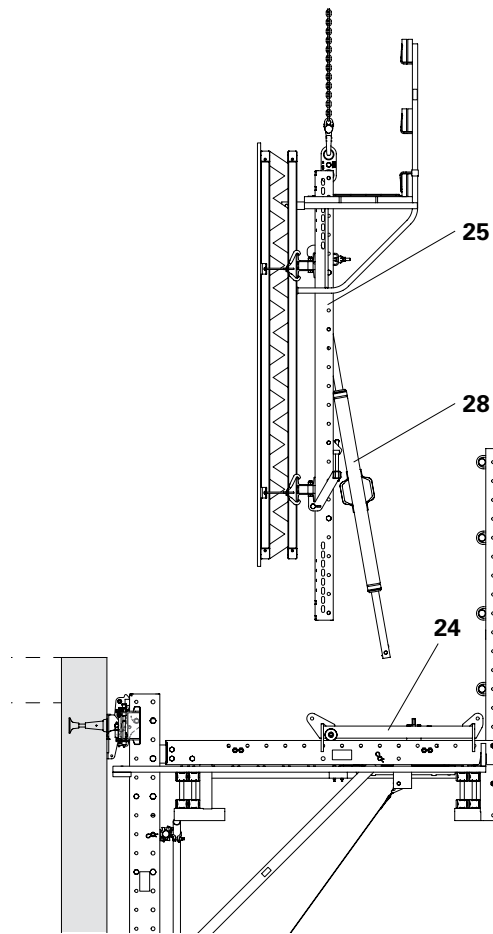

Fig. C3.04

4. Mount the Strongback (**25**) on the Carriage (**24.1**) using 1x fitting pin \varnothing 21 x 120 (**15**) and cotter pin 4/1 (**16**). The crane continues to carry the load.
5. Mount the Formwork Spindle on the Carriage (**24.2**) using fitting pins and cotter pins.
6. Remove load from crane and release crane lifting gear.
7. Mount the Leading Anchor (**47**). (Fig. C3.05)

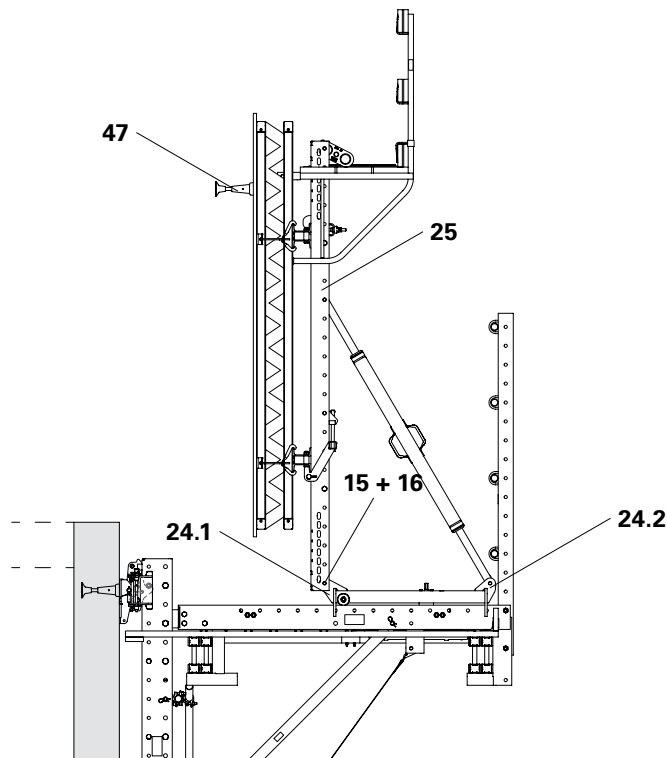

Fig. C3.05

Mounting the Leading Anchor

Preparation

Measure out the position of the Leading Anchor and mark on the surface of the formlining.

Standard: Advancing Bolt



- Ensure there is sufficient distance to the formwork girder. (Fig. C3.06a)
- If the distance is insufficient, the Advancing Bolt must be used.
- Before concreting takes place, check all anchor components, assembly and position.
- Before striking, first release the Advancing Bolts!

Components per Climbing Anchor

- 47.5** Climbing Cone-2 M30 / DW 20
- 47.6** Tie Rod DW 20
- 47.2** Threaded Anchor Plate DW 20
- 42.1** Advancing Bolt M30
- 42.3** Anchor Positioning Plate M30
- 135** Hex. Wood Screw DIN 571 6 x 20

Assembly

1. Drill a suitable hole in the formlining. (M30 = hole size Ø 32 mm)
 2. Attach Anchor Positioning Plate M30 (**42.3**) to the rear side of the formlining matching the drilled hole using 4x hex. wood screws DIN 571 6 x 20 (**135**).
 3. Insert the Advancing Bolt M30 (**42.1**) from the rear side through the drilled hole.
 4. Screw the Climbing Cone-2 M30/ DW 20 (**47.5**) from the front side on the Advancing Bolt M30 (**42.1**).
 5. Screw the Tie Rod DW 20 (**47.6**) onto the Climbing Cone-2 M30/ DW 20 (**47.5**).
 6. Screw the Threaded Anchor Plate DW 20 (**47.2**) onto the Tie Rod DW 20 (**47.6**).
- (Fig. C3.06)



For fault-free functioning of the climbing unit, the exact alignment of the anchoring in all 3 axes is decisive.

- Measure the anchoring precisely (perpendicular, chalk line) and mount securely in position.
- To ensure a secure position, fix the Threaded Anchor Plate (**47.2**) to the reinforcement with wire.
- Install additional reinforcement bars vertically and horizontally.



In order that the Climbing Cone can subsequently be recovered, the surfaces resting against the concrete and the internal thread for the Tie Rod can be carefully greased.

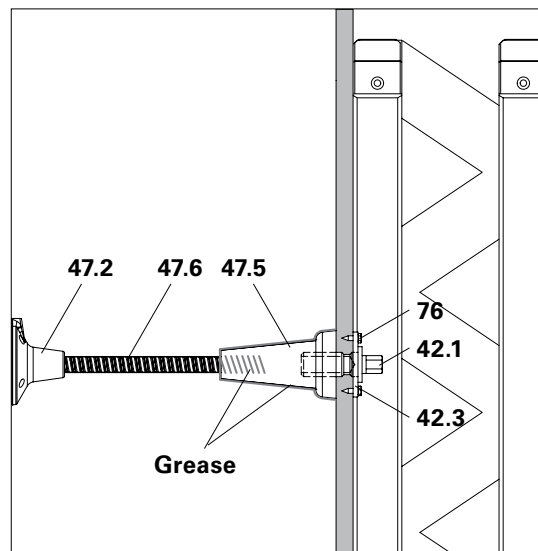

Fig. C3.06

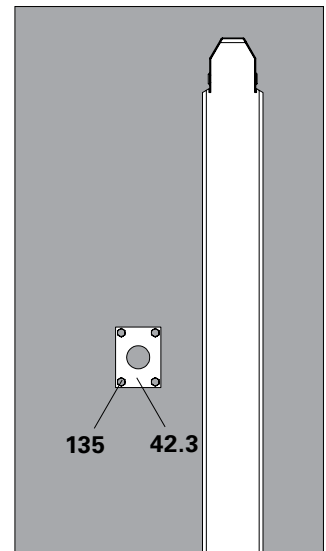

Fig. C3.06a

Alternatively: Anchor Positioning Stud



- To ensure a secure position, fix the Threaded Anchor Plate DW 20 (**47.2**) to the reinforcement using wire.
- Before concreting takes place, check all anchor components, assembly and position.
- If possible, use the mounting with the Advancing Bolt as the connection is more stable.
- When striking, the nails must be pulled through the plywood. Therefore, nails are to be hammered in as straight as possible.

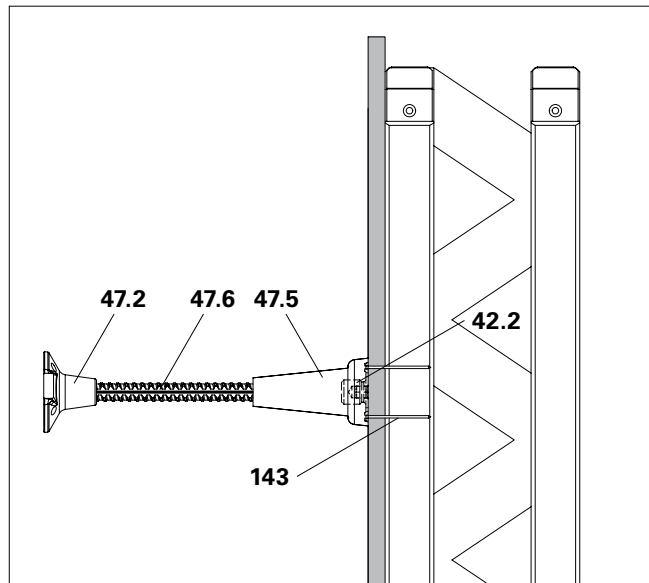

Fig. C3.07

Components per Climbing Anchor

47.1	Screw-On Cone-2 M30/DW 26	1x
47.5	Climbing Cone-2 M30 / DW 20	1x
47.6	Tie Rod DW 20	1x
47.7	Threaded Anchor Plate DW 26	1x
47.2	Threaded Anchor Plate DW 20	1x
42.2	Anchor Positioning Stud M30	1x
143	Wire Nail 3 x 80	6x

Assembly

1. Nail Anchor Positioning Stud M30 (**42.2**) to the front side of the formlining using 6x wire nails 3 x 80 (**143**).
2. Screw Climbing Cone-2 M30/DW 20 (**47.5**) onto the Anchor Positioning Stud M30 (**42.2**).
3. Screw the Tie Rod DW 20 (**47.6**) onto the Climbing Cone-2 M30/DW 20 (**47.5**).
4. Screw the Threaded Anchor Plate DW 20 (**47.2**) onto the Tie Rod DW 20 (**47.6**).

(Fig. C3.07)

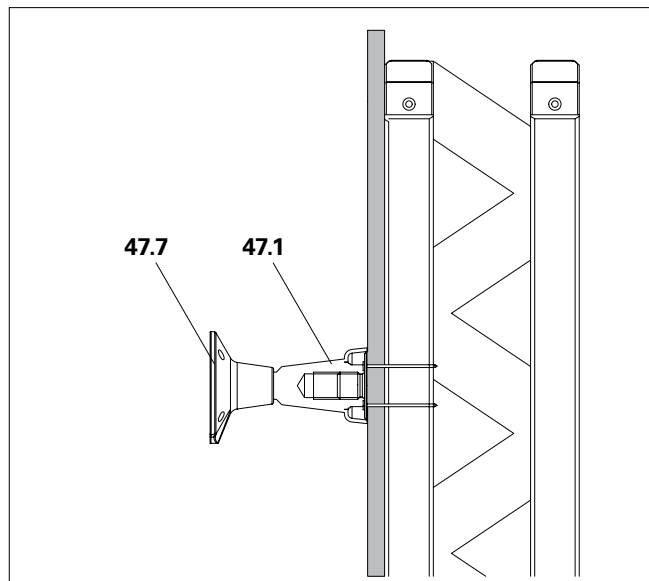

Fig. C3.08

Alternatively

Anchoring with the Screw-On Cone-2 (**47.1**) and Threaded Anchor Plate 26 (**47.7**). (Fig. C3.08)

Concreting

1. Move the Carriage (24) to the concreting position.
 2. Align the formwork with the Formwork Spindle (28) and the Adjusting Unit SRU (27) both vertically and horizontally.
 3. Using the Carriage, pretension the formwork against the wall.
 4. Align formwork.
 5. Reinforce and concrete the concreting section.
- (Fig. C3.09)

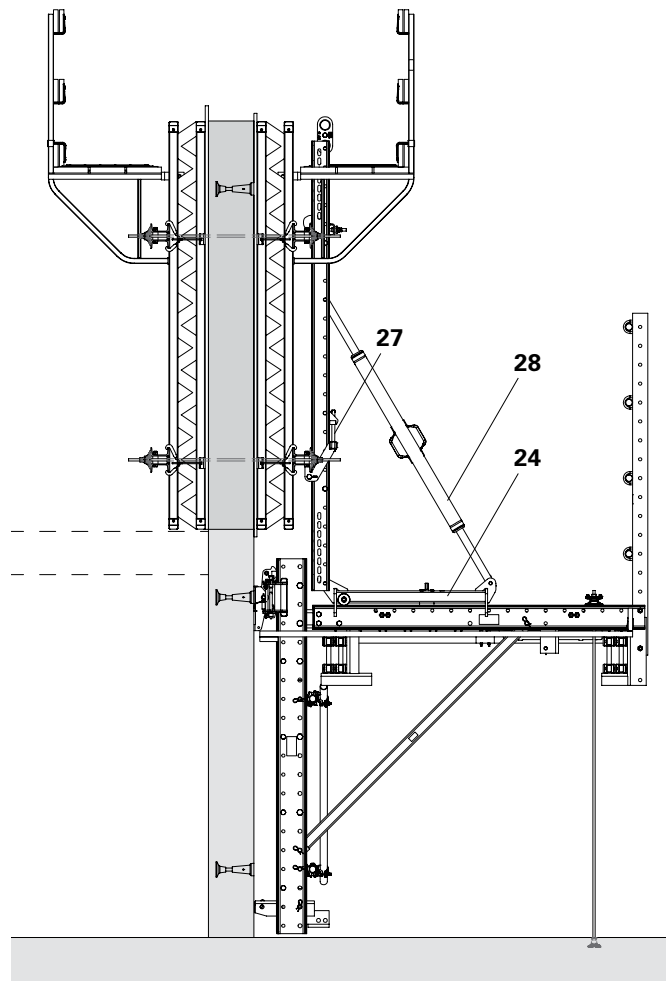

Fig. C3.09

Initial Moving Procedure

The initial moving procedure is carried out in part unguided by Climbing Shoes.



Warning

The climbing unit may move unexpectedly. As a result, persons in the vicinity could be hit by components and injured.

- ⇒ Maintain an appropriate safety distance.
- ⇒ Use a guide rope when moving components.
- ⇒ Ropes are to be held so that they can be released quickly at any time.
- ⇒ Be prepared for any sudden movements.

Moving

1. Release formwork anchor and the mounting of Leading Anchor.
2. Remove transition areas and other connections between the formwork and climbing units.
3. Retract Carriage (24).
4. Mount top Climbing Shoe (50a), see Section "Assembling the suspension" on page 108.
5. Attach crane lifting gear to top end of the Strongback (25).
6. Personnel are to leave the working platform.
7. Lift the bracket unit to the next concreting section using the crane.
 - Climbing Rail Hinge (8) swivels around the bottom Climbing Shoe in the pressure position.
8. Insert the bracket unit from below into the Climbing Shoes until both climbing pawls audibly engage.
9. From a safe position, detach the crane lifting gear. (Fig. C3.10)

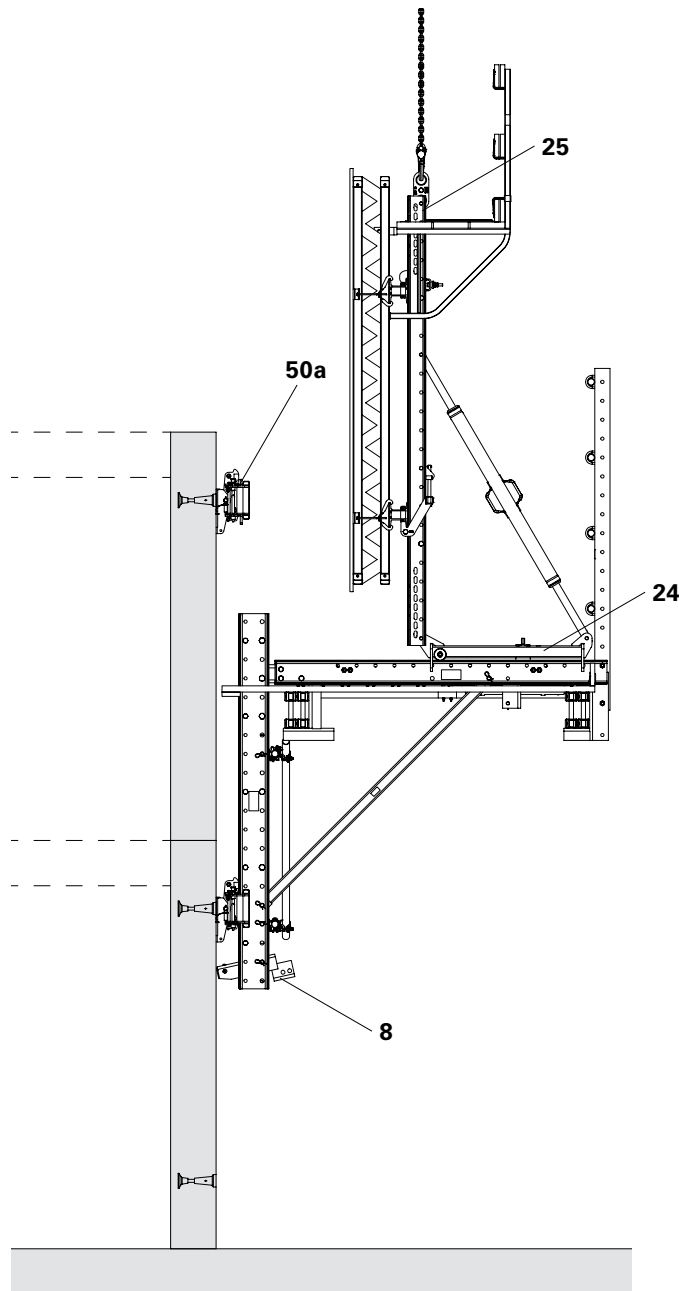

Fig. C3.10



- In order to attach the climbing unit to the crane in a vertical position, determine the suitable return path for the Carriage by means of tests.
- Guide the bracket unit with ropes with site personnel in a safe position.



- Are both Climbing Rails suspended correctly in both Climbing Shoes?
- Has the Climbing Rail Hinge swiveled into the pressure position?

General

For pre-assembly, there must be a sufficiently large, level and load-bearing assembly area available. In addition, allow sufficient space for temporary storage.

A crane or other lifting equipment is required.

Any intermediate status is to be correctly secured by means of temporary supports to prevent any tipping over.

Assembly is carried out on aligned timbers.

Pre-Assembling the Climbing Rails

Components

- 2** Bottom Climbing Rail RCS
- 87** Scaffold Tube Bracing
- 91** Scaffold Tube Connector LPS/RCS
Ø 48
- 97** Swivel Coupler SW 48/48

Assembly

1. Position bottom Climbing Rails (**2**) on timbers and align in accordance with project-specific bracket dimensions (c).
2. Mount Climbing Rails with scaffold tubes and scaffold tube connectors Ø 48 (**91**) in accordance with project-specific dimensions ($h_1 + h_2$).
3. Diagonally connect scaffold tube with swivel couplers (**97**).

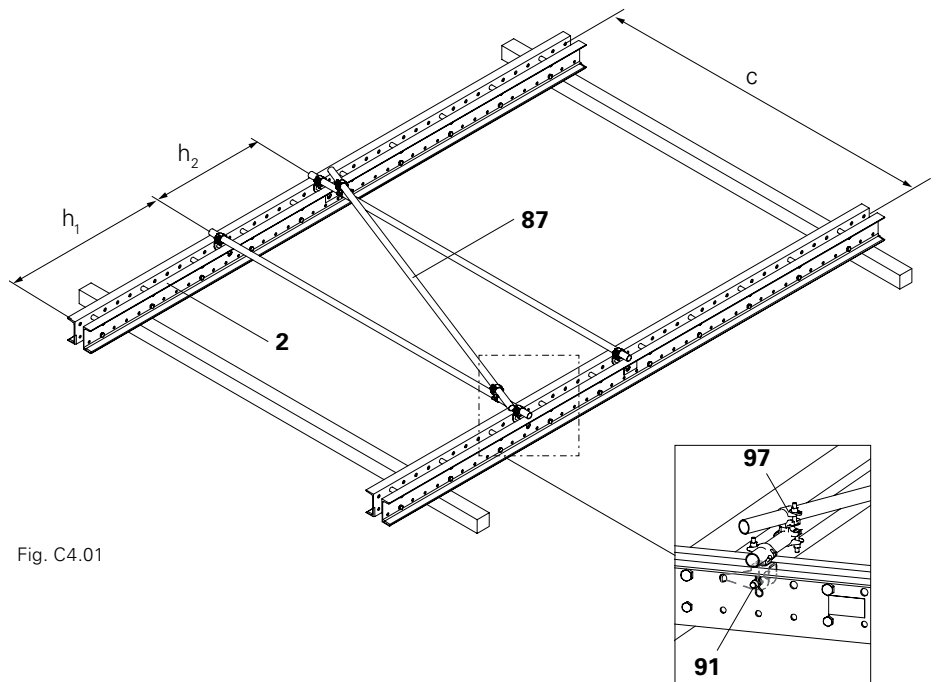

Fig. C4.01



Position the bottom timbers as close as possible to the end of the Climbing Rail. This reduces the risk of damage during subsequent lifting.

Mounting the Spacer M20

In some cases, the additional installation of a Spacer M20-82 (**3**) may be required as a Climbing Bolt in the Climbing Rail, see "Additional Spacers" on Page 32.

Components

- 3** Spacer M20-82
- 3.1** Spacer Tube $\text{Ø}26.9 \times 2.6$ 82
- 3.2** Bolt ISO 4014 M20 x 120-8.8
- 3.3** Nut ISO 7042 M20-8

Assembly

1. Position Spacer Tube $\text{Ø} 26$ (**3.1**) of the Spacer M20 (**3**) in the Climbing Rail RCS with the help of a hammer.
2. Insert bolt M20x120 (**3.2**) through the holes $\text{Ø} 21$ of the Climbing Rail and through the Spacer Tube.
3. Attach self-locking nut M20-8 (**3.3**) (SW 30) to the bolt and tighten. Tightening torque min. 100 Nm. (Fig. C4.02)

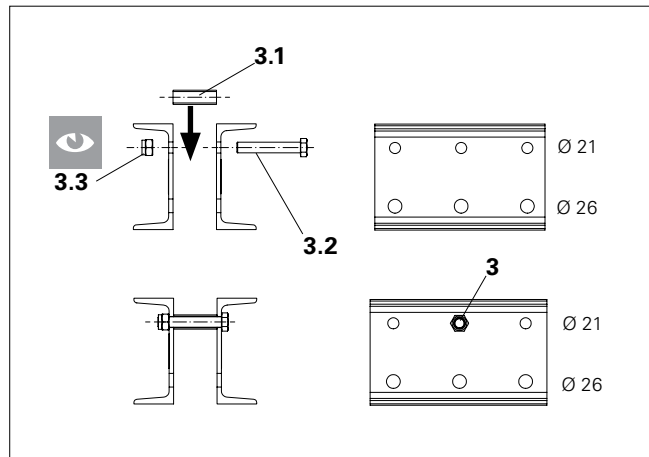

Fig. C4.02



Has the nut (**3.3**) been tightened?
(Fig. C4.02)



- Spacers M20 (Climbing Bolts) must not be moved in the Climbing Rail, but additionally installed. The stroke of the Climbing Device allows a maximum distance of 50 cm from the Spacers.
- It may be necessary to release adjacent Spacers in the Climbing Rail. After mounting the additional Spacer, re-tighten all previously loosened bolts. Tightening torque min. 100 Nm.

Re-positioning the Spacer M24

In some cases, re-positioning of the Spacers M24 in the Climbing Rail or Enclosure Post is required.

Components

- 4** Spacer M24-82
- 4.1** Spacer Tube \varnothing 33.7 x 4 82
- 4.2** Bolt ISO 4014 M24 x 130-8.8
- 4.3** Nut ISO 7042 M24-8

Assembly

1. Release nut M24-8 (**4.3**) (SW 36).
2. Remove bolt M24 x 130 (**4.2**).
3. Re-position Spacer Tube \varnothing 33.7 (**4.1**) of Spacer M24 with the help of a hammer.
4. Insert bolt M24 x 130 (**4.2**) through the holes \varnothing 26 of the Climbing Rail and through the Spacer Tube.
5. Attach self-locking nut M24-8 (SW 36) onto the bolt and tighten. Tightening torque min. 150 Nm. (Fig. C4.03)

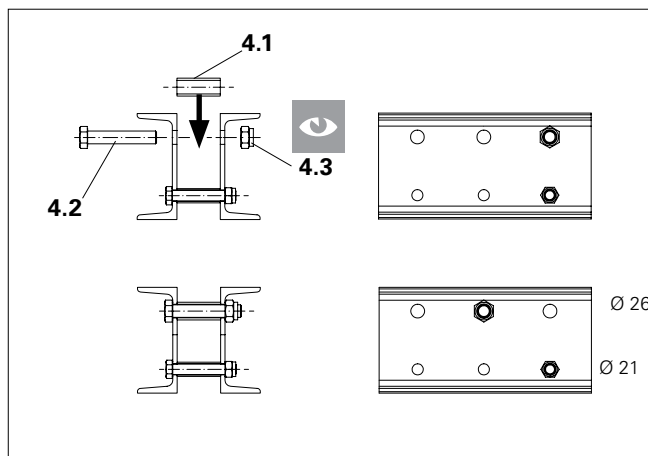

Fig. C4.03



Has the nut (**4.3**) been tightened?
(Fig. C4.03)



It may be necessary to release adjacent Spacers in the Climbing Rail. After mounting the additional Spacer, re-tighten all previously loosened bolts. Tightening torque min. 150 Nm.

Pre-Assembling the Platforms

Pre-assemble intermediate platform (Fig. C4.04 + C4.05) and finishing platform (Fig. C4.06 + C4.07). See Section "Mounting the working platform" on page 68.

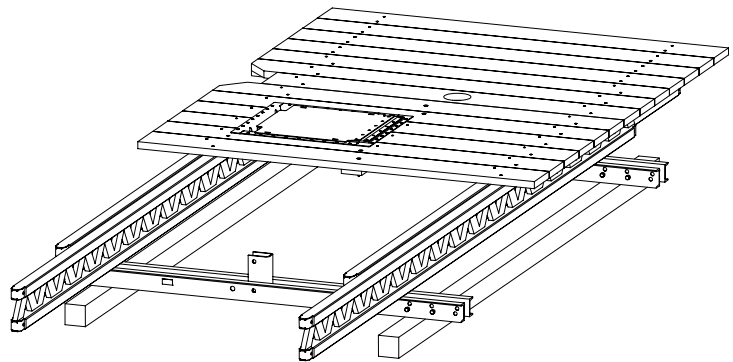

Fig. C4.04

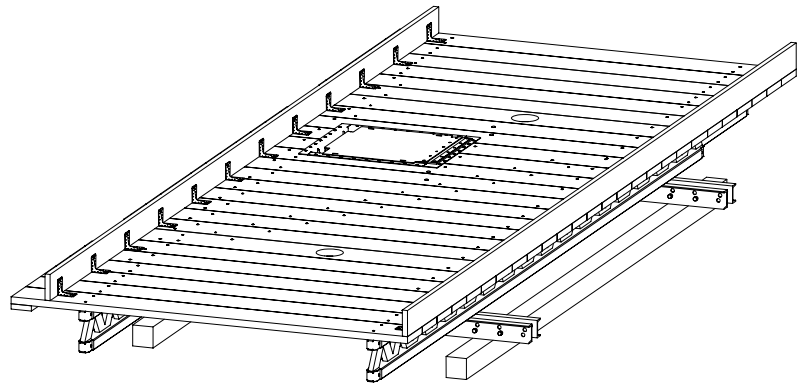

Fig. C4.05

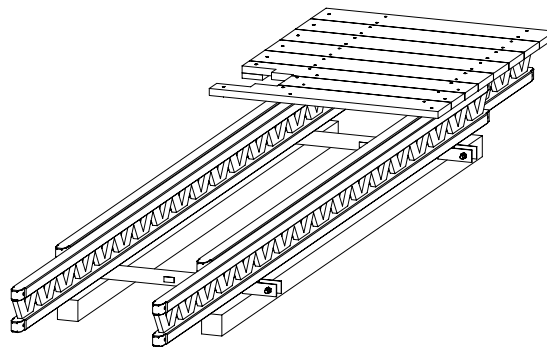

Fig. C4.06

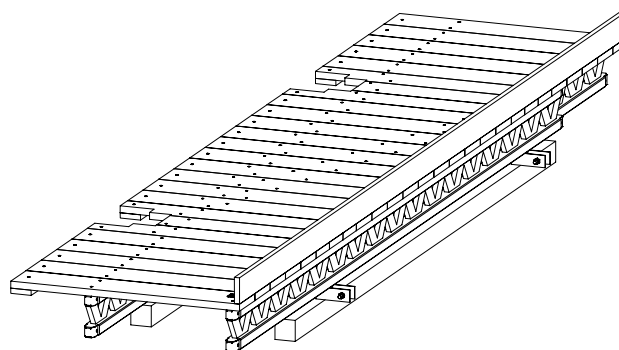

Fig. C4.07

Horizontal Assembly

Mounting the Intermediate Platform

Components

- 2** Bottom Climbing Rail RCS
- 12** Diagonal Strut l = 1416
- 15** Fitting Pin \varnothing 21 x 120
- 16** Cotter Pin 4/1
- 31** Intermediate Platform Beam

Assembly

1. Attach the intermediate platform to the crane lifting gear using fitting pin \varnothing 21 mm (**15**) and cotter pin 4/1 (**16**) and transport to the Climbing Rail (**2**).
2. Fix the Intermediate Platform Beam (**31**) using the provided hex. bolt M24 x 130 (**31.1**) and nut (**31.2**).
3. Mount the Diagonal Strut (**12**) on the Intermediate Platform Beam and Climbing Rail using the provided 2x bolts 25 x 180 (**12.1**) and 2x cotter pins. (Fig. C4.08)

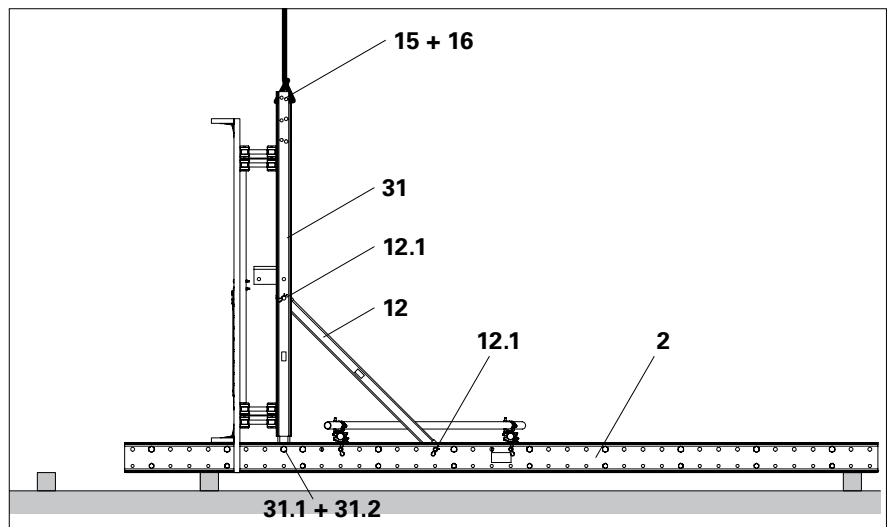

Fig. C4.08

Assembling the Finishing Platform

Components

- 33** Finishing Platform
- 34** Finishing Platform Beam
- 81** Guardrail Post U100 384 RCS
- 88** Steel Scaffold Tube \varnothing 48.3 x 3.2
- 89** Clamp A64 DIN 3570

Assembly

1. Attach the finishing platform (**33**) to the crane lifting gear and transport to the Climbing Rail.
2. Tighten the finishing platform using hex. bolts M24 x 130 (**34.2**) and nuts and temporarily support.
3. Fix the Guardrail Post (**81**) between the finishing platform and intermediate platform using 2x bolts M20 x 120 (**81.1 + 34.1**) and nuts.
4. As anti-fall protection, connect Scaffold Tubes (**88**) to Clamp A64 (**89**). (Fig. C4.09)

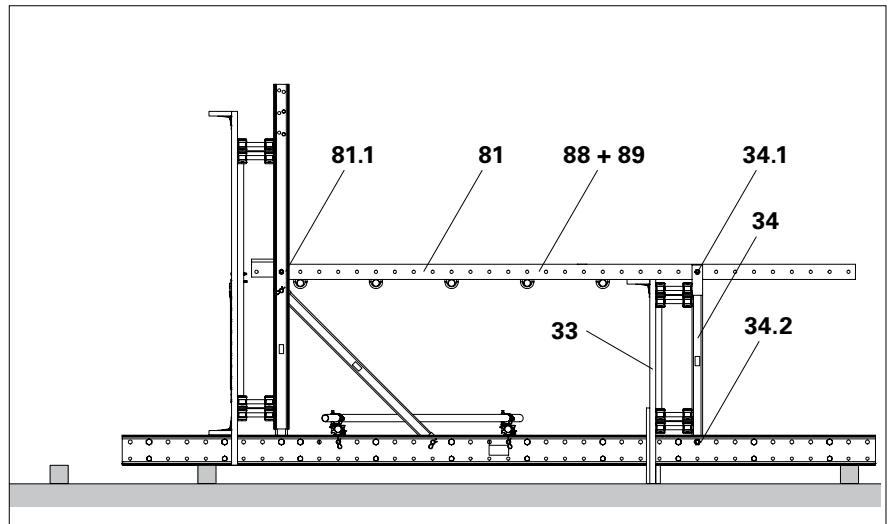

Fig. C4.09

Dismantling the Formwork

Components

- 15** Fitting Pin \varnothing 21 x 120
- 16** Cotter Pin 4/1
- 24** Carriage RCS
- 25** Steel Waler Universal SRU L = 2.72
- 28** Heavy-Duty Spindle SLS 200/300
- 50** Climbing Shoe RCS

Dismantling

1. Release formwork anchor and the mounting of Leading Anchor.
 2. Remove transition areas and connections between the climbing units.
 3. Retract Carriage (**24**).
 4. Mount Wall and Climbing Shoes (**50a**) on the Leading Anchor.
 5. Closing the Climbing Shoe (**50a**) and deactivate the climbing pawl, see Section "D5 Operating the Climbing Shoe" on page 113.
 6. Mount the ropes on the pawl locking devices of the Climbing Shoe (**50b**) so that they can be operated from below with site personnel in a safe position.
 7. Attach crane lifting gear to the Strongback (**25**), see Section "Mounting the formwork" on page 75, and tension with the crane.
 8. Remove the Formwork Spindle (**28**).
 9. Release fitting pins (**15**) and cotter pins (**16**) between the Strongback and Carriage.
 10. Lift out the formwork and store it in a suitable place.
- (Fig. C4.10)

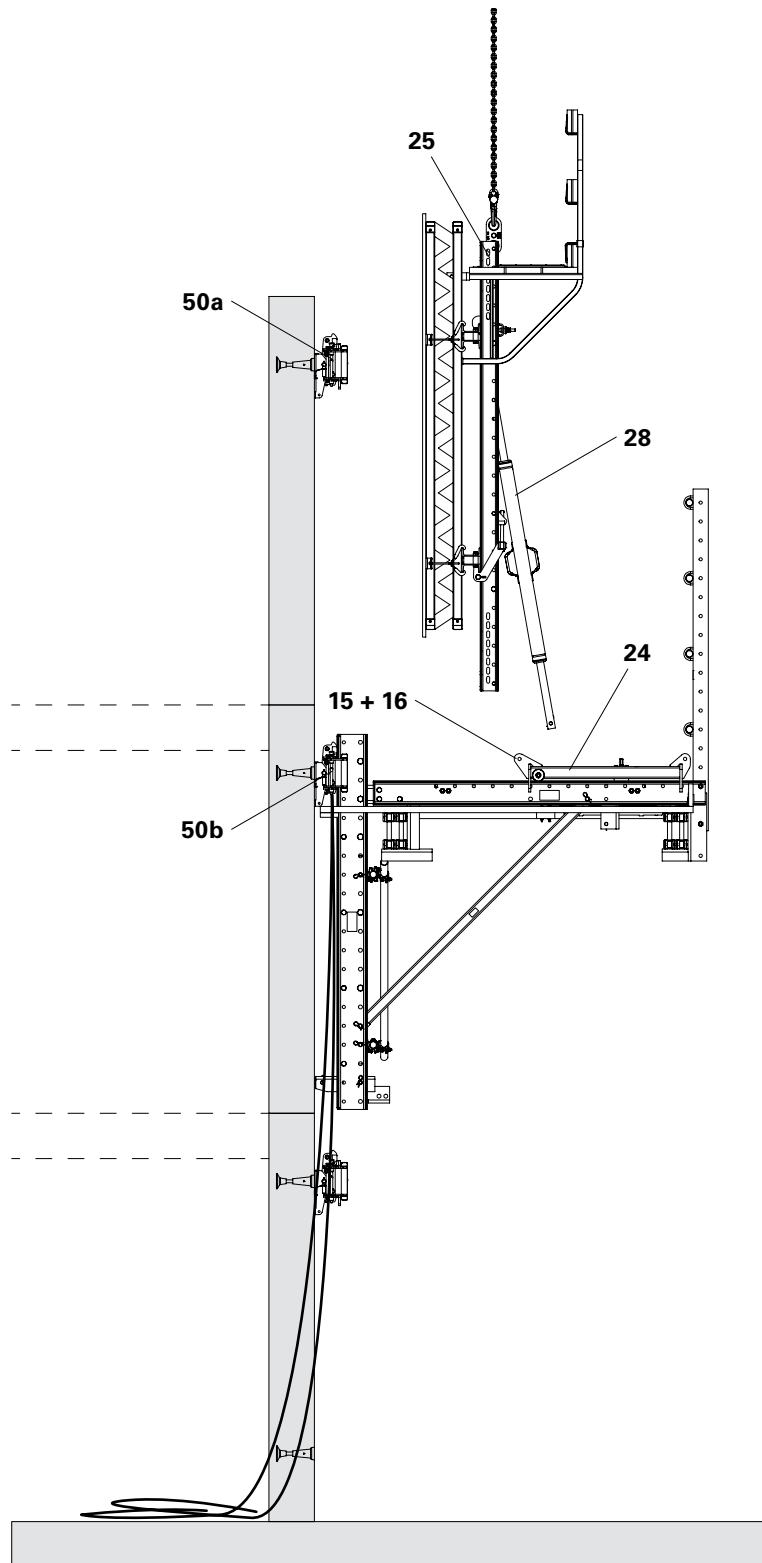

Fig. C4.10

Dismantling the Bracket

Components

- 1** Top Climbing Rail RCS
- 79** Guardrail Post RCS 226
- 144** Tension Belt L = 5.70 m, 2.5 t

Assembly

1. Tighten the anti-fall protection with Tension Belt (**144**) between the Guardrail Post (**79**) and Climbing Rail (**1**).
2. Attach bracket unit (**K**) to the Carriage (fitting pin $\varnothing 21 \times 120$), lift out of the Climbing Shoes and place with the Climbing Rails on timbers. (Fig. C4.11)

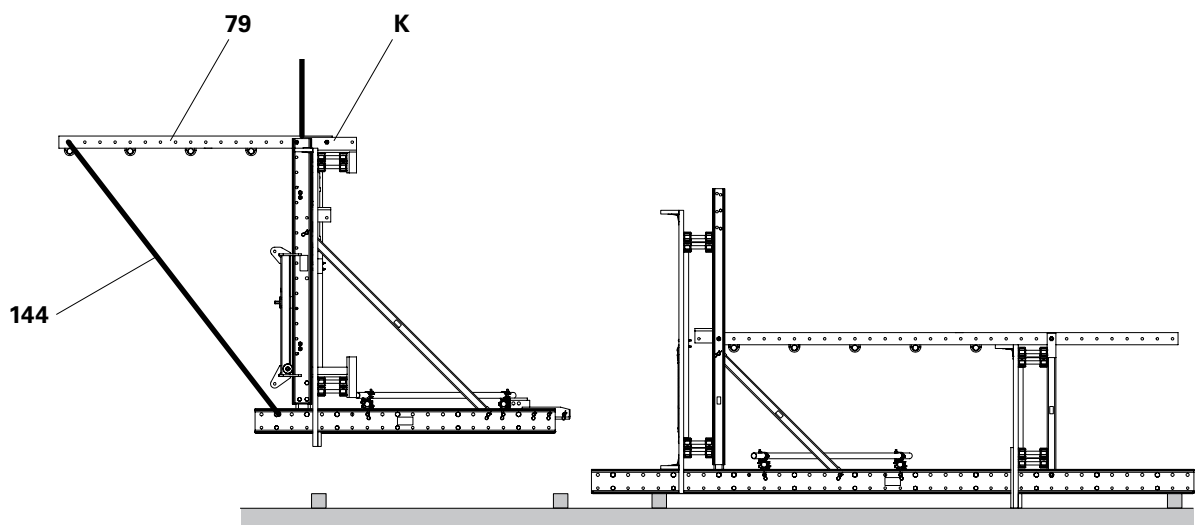

Fig. C4.11

Attaching the Finishing Platform Unit

Components

- 8** Climbing Rail Hinge RCS
- 15** Fitting Pin \varnothing 21 x 120
- 16** Cotter Pin 4/1
- 21** Crossbeam Unit RCS 220 VARIO
- 31** Intermediate Platform Beam
- 81** Guardrail Post U100 384 RCS
- 88** Steel Scaffold Tube \varnothing 48.3 x 3.2
- 106** Bolt ISO 4014 M20 x 120-8.8
- 115** Nut ISO 7040 M20-8
- 144** Tension Belt L = 5.70 m, 2.5 t



- Ensure that the bracing is sufficiently stable in order not to deform the Guardrail Posts. Otherwise completely remove the top Guardrail Posts.
- Ensure that any installed Climbing Rail Extensions at the bottom end of the climbing unit are not deformed. If necessary, brace with timbers fixed in an adjacent position.

1. Mount the Framework Spindle (**13**) on the Crossbeam connection (**21.1**) and the connection of the Intermediate Platform Beam (**31.1**) using 2x fitting pins \varnothing 21 x 120 (**15**) and cotter pins (**16**).
2. Fix the Guardrail Post (**81**) to the Crossbeam connection (**21.2**) using bolt M20 x 120 (**106**) and nut M20 (**115**).
3. Loosely mount the Guardrail Post between 2x fitting pins \varnothing 21 x 120 (**15**) and cotter pins (**16**) on the connection of the Intermediate Platform Beam (**31.2**).
4. As anti-fall protection, connect Scaffold Tubes (**88**) to Clamp A64. (Fig. C4.12)

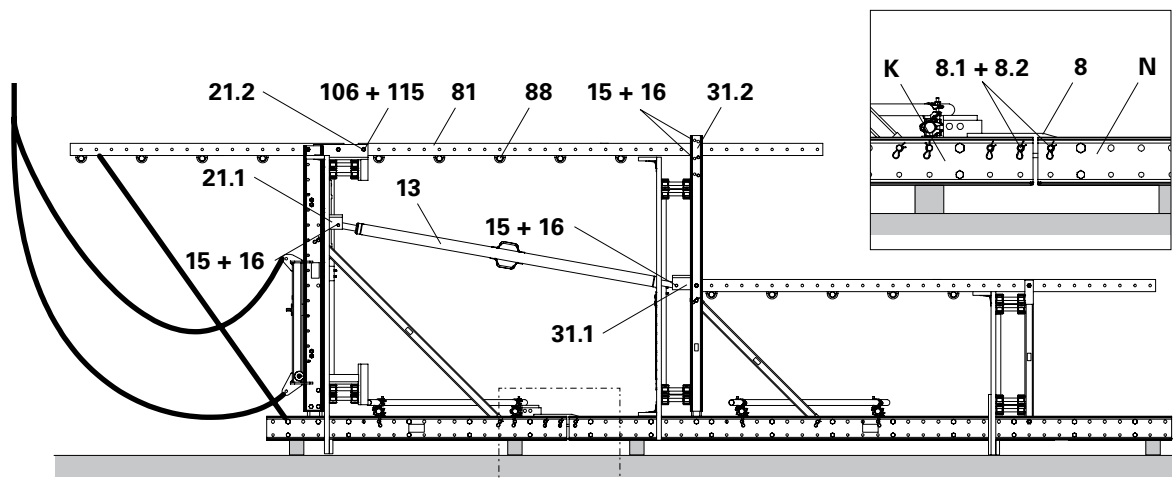

Fig. C4.12

Mounting the Climbing Unit

Components

- 24** Carriage RCS
- 50** Climbing Shoe RCS
- 79** Guardrail Post RCS 226

Assembly

1. Attach ropes for guiding the climbing unit.
2. Attach climbing unit to the Carriage (**24**) using 2x fitting pins $\varnothing 21 \times 120$ and slowly lift up. Crane sling angle $\alpha \leq 30^\circ$.
→ Attach the lifting equipment to the Guardrail Posts (**79**).
3. Continue to slowly lift the climbing unit and insert it into the closed Climbing Shoes from above.
4. From a safe position, pull on the pawl locking device (**50.4**) of the middle Climbing Shoe with the rope until the required Spacer is directly positioned above, then release.
5. Place the climbing unit on the middle Climbing Shoes so that the complete weight of the unit is supported.
6. Release the crane lifting gear, remove the bracing for the anti-fall protection or reinstall the previously dismantled fall protection of the working platform using PPE.
(Fig. C4.13)
7. Mount formwork, see Section "Mounting the formwork" on page 75. (Fig. C4.14)

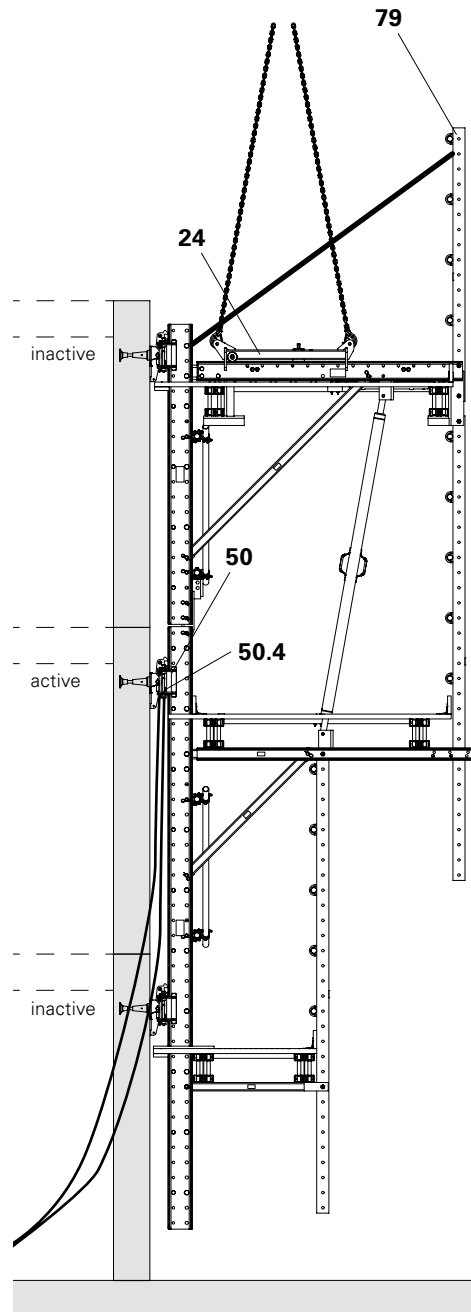

Fig. C4.13

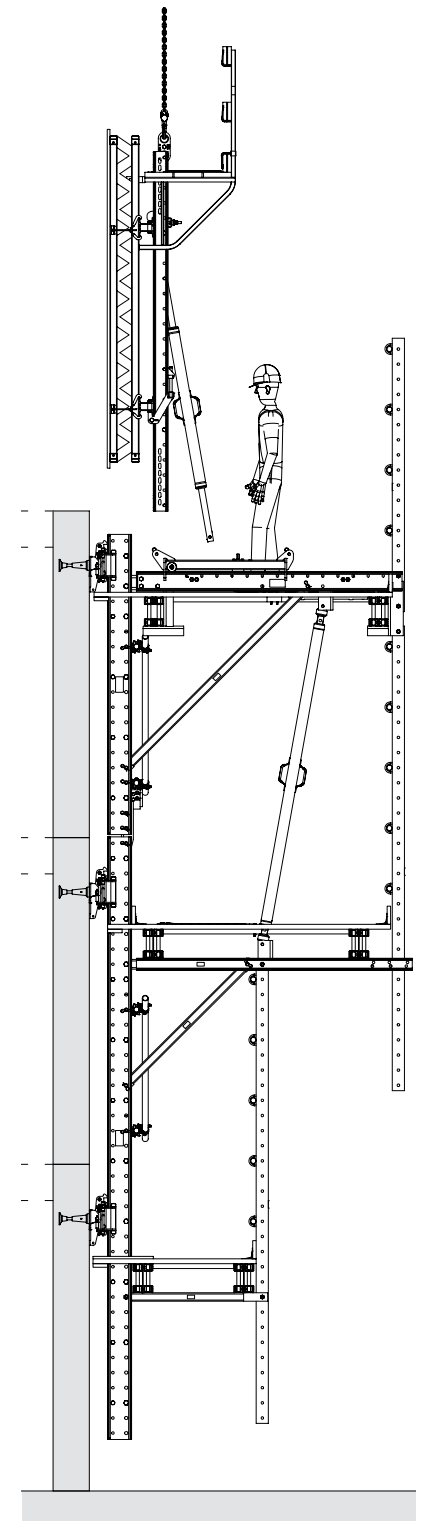

Fig. C4.14

Vertical Assembly

Alternatively, the finishing platform unit can be vertically pre-assembled on another part of the building. Suitable anchoring must be available. Due to the vertical assembly, platforms and the finishing platform unit do not have to be turned by crane.



The assembly sequence assumes that work is carried out for a short time under a positively-connected load.

Pre-assembling the finishing platform unit

Components

- 2** Bottom Climbing Rail RCS
- 12** Diagonal Strut I = 1416
- 31** Intermediate Platform Beam
- 33** Finishing Platform
- 34** Finishing Platform Beam
- 81** Guardrail Post RCS 384
- 87** Scaffold Tube Bracing
- 88** Steel Scaffold Tube Ø 48.3 x 3.2
- 89** Clamp A64 DIN 3570
- 106** Bolt ISO 4014 M20 x 120-8.8
- 115** Nut ISO 7040 M20-8

Assembly

1. Install the Climbing Rails (**2**) with the mounted Scaffold Tube Bracing (**87**) on the building.
 2. Fix the Intermediate Platform Beam (**34**) to the Climbing Rails using the provided hex. bolts M24 x 130-8.8 (**34.1**) and nuts (**34.2**) and temporarily support.
- (Fig. C4.15)

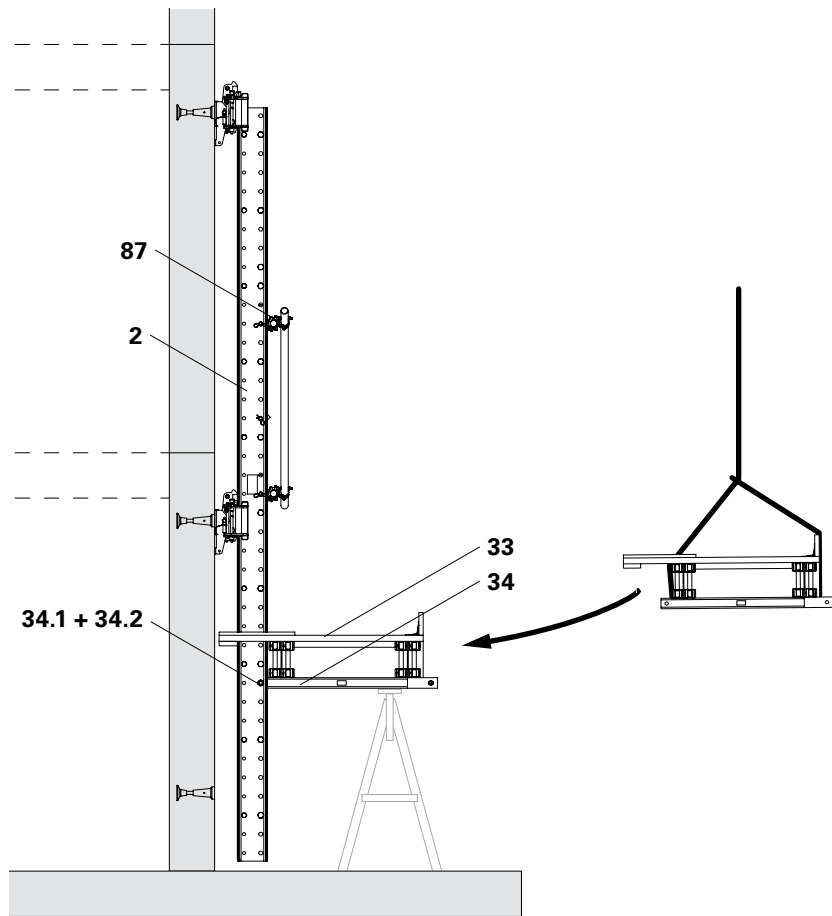

Fig. C4.15

3. Attach the pre-assembled intermediate platform on the girders to the crane lifting gear and transport to the Climbing Rail (2).
Crane sling angle $\alpha \leq 30^\circ$; crane sling length ≥ 4 m.
4. Fix the Intermediate Platform Beam (31) using the provided hex. bolt M24 x 130 (31.1) and nut (31.2).
5. Mount the Diagonal Strut (12) on the Intermediate Platform Beam and Climbing Rail using the provided 2x bolts 25 x 180 (12.1) and 2x cotter pins (12.2).
6. Remove crane lifting gear.
7. Fix the Guardrail Post (81) between the finishing platform and intermediate platform using 2x bolts M20 x 120 (106 + 34.1) and nuts M20 (115 + 34.2). (A screw set is supplied with the finishing platform.)
8. As anti-fall protection, connect Scaffold Tubes (88) to Clamp A64 (89).

(Fig. C4.15a)



- After assembly, mount the planking above the Platform Beams on the Climbing Rail so that it can be attached to the crane lifting gear.
- For attaching to the crane lifting gear, wrap textile slings, e.g. round slings, around the girders.
- Alternatively, wrap round slings completely around the finishing platform outside of the finishing platform girders.

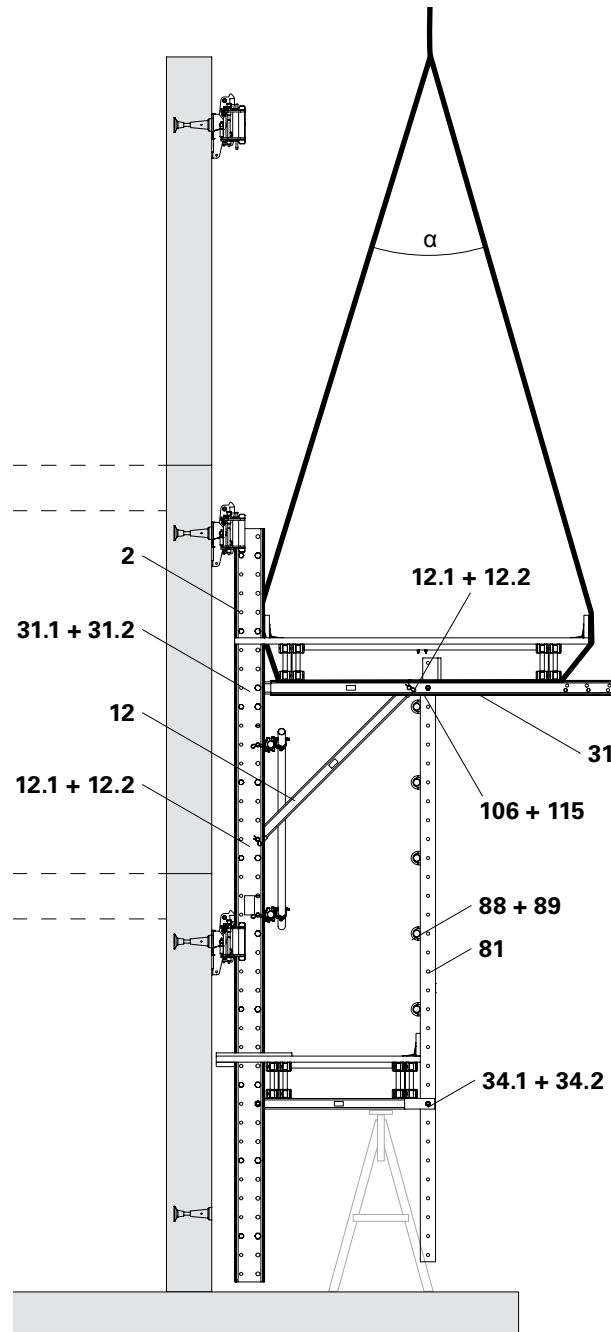

Fig. C4.15a

Supplementing the Bracket Unit

Components

- 13** Heavy-Duty Spindle SLS 260/360
- 21** Crossbeam Unit RCS 220 VARIO
- 81** Guardrail Post U100 384 RCS

Assembly

1. Dismantle the bracket unit as in Section "Horizontal assembly" on page 84 and transport to the assembly area.
2. On the suspended platform, mount the Framework Spindle (**13**) on the Crossbeam connection (**21.1**) using fitting pins $\varnothing 21 \times 120$ (**15**) and cotter pins (**16**).
3. Fix the Guardrail Post (**81**) with the pre-assembled scaffold tubes to the Crossbeam connection (**21.2**) using the provided bolts M20 x 100 (**81.1**) and nuts M20 (**81.2**).

(Fig. C4.16)

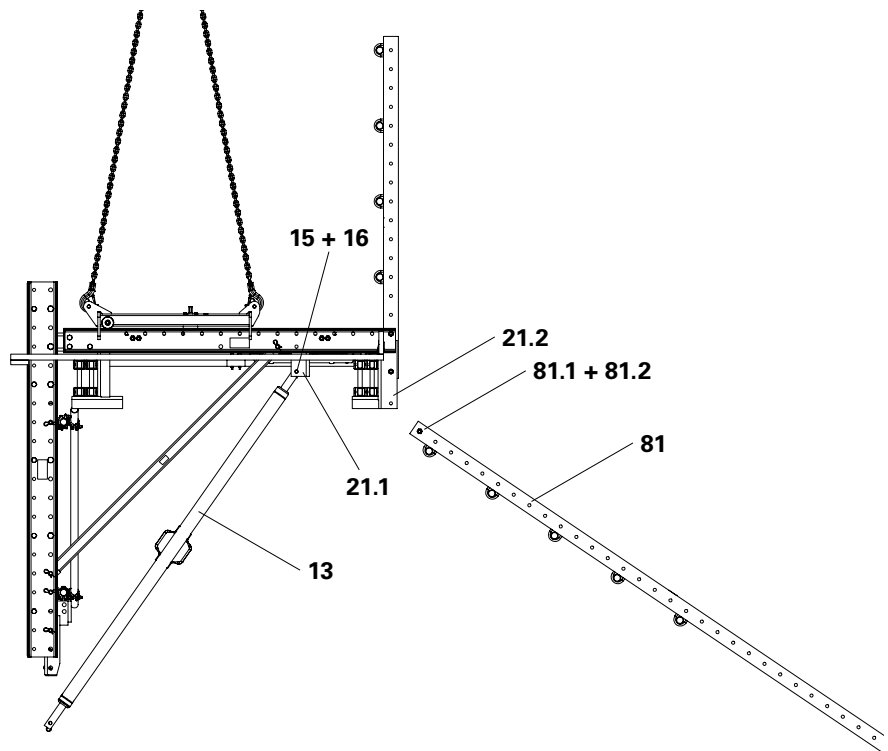

Fig. C4.16

Connecting the Climbing Unit



Warning

Risk of falling during assembly!
A fall can result in serious injuries
or even death.
⇒ Use PPE.

Components

See the following page.

Assembly

1. Transport the bracket unit to the pre-assembled finishing platform unit.

(Fig. C4.17)

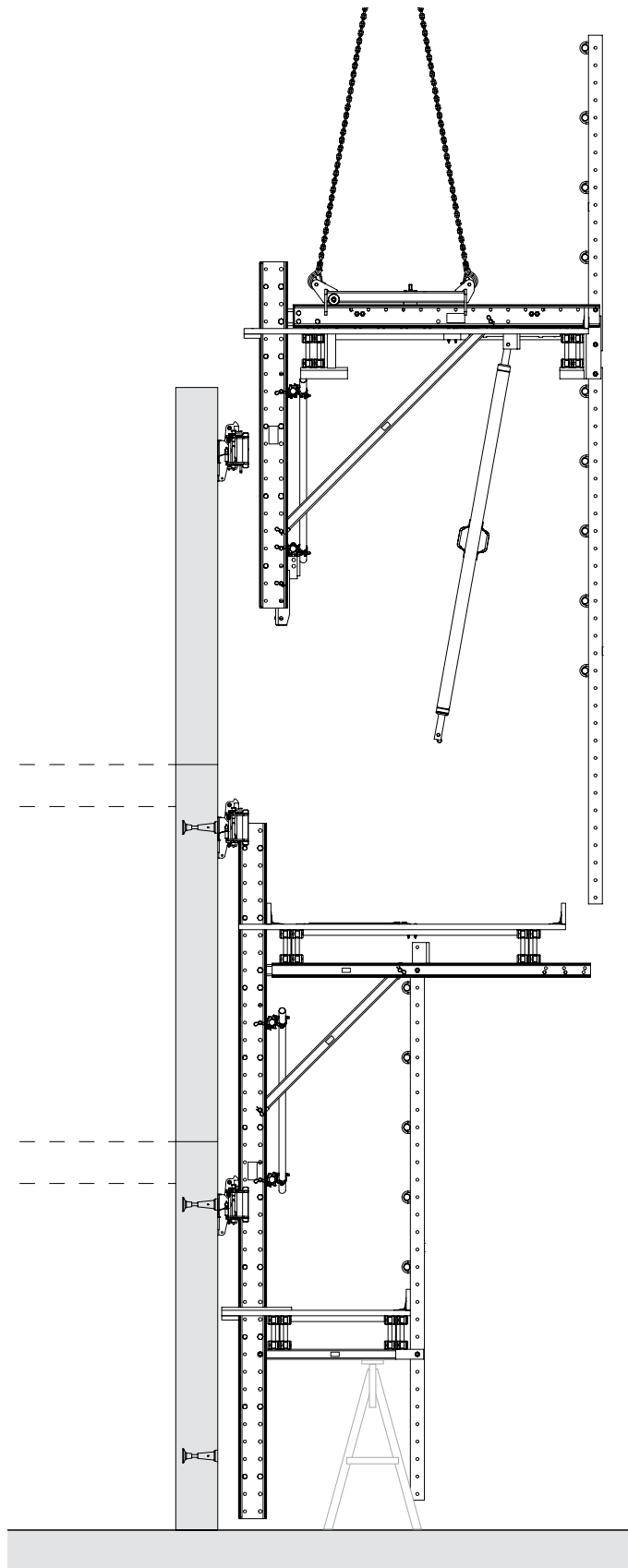

Fig. C4.17

- With PPE from the intermediate platform:
- 2. Additionally mount the Climbing Rail Hinge (**8**) 1x in the bracket unit (**K**) and 1x in the finishing platform unit using 2x bolts $\varnothing 25 \times 180$ (**8.1**) and cotter pins 4/1 (**8.2**) which have been provided.
- 3. Mount the Framework Spindle (**13**) on the connection of the Intermediate Platform Beam (**31.1**) using fitting pins $\varnothing 21 \times 120$ (**15**) and cotter pins (**16**).
- 4. Loosely mount the Guardrail Post (**81**) between 2x fitting pins $\varnothing 21 \times 120$ (**15**) and cotter pins (**16**) on the connection of the Intermediate Platform Beam (**31.2**).

(Fig. C4.18)

- 5. Lift out the climbing unit and suspend on the building, see Section "Suspending the climbing unit" on page 89.
- 6. Mount formwork, see Section "Mounting the formwork" on page 75.



Depending on the crane capacity, first install the finishing platform unit on the building, then position on the temporarily stored, supplemented bracket unit.

Components

- 8** Climbing Rail Hinge RCS
- 13** Heavy-Duty Spindle SLS 260/360
- 15** Fitting Pin $\varnothing 21 \times 120$
- 16** Cotter Pin 4/1
- 31** Intermediate Platform Beam
- 81** Guardrail Post U100 384 RCS

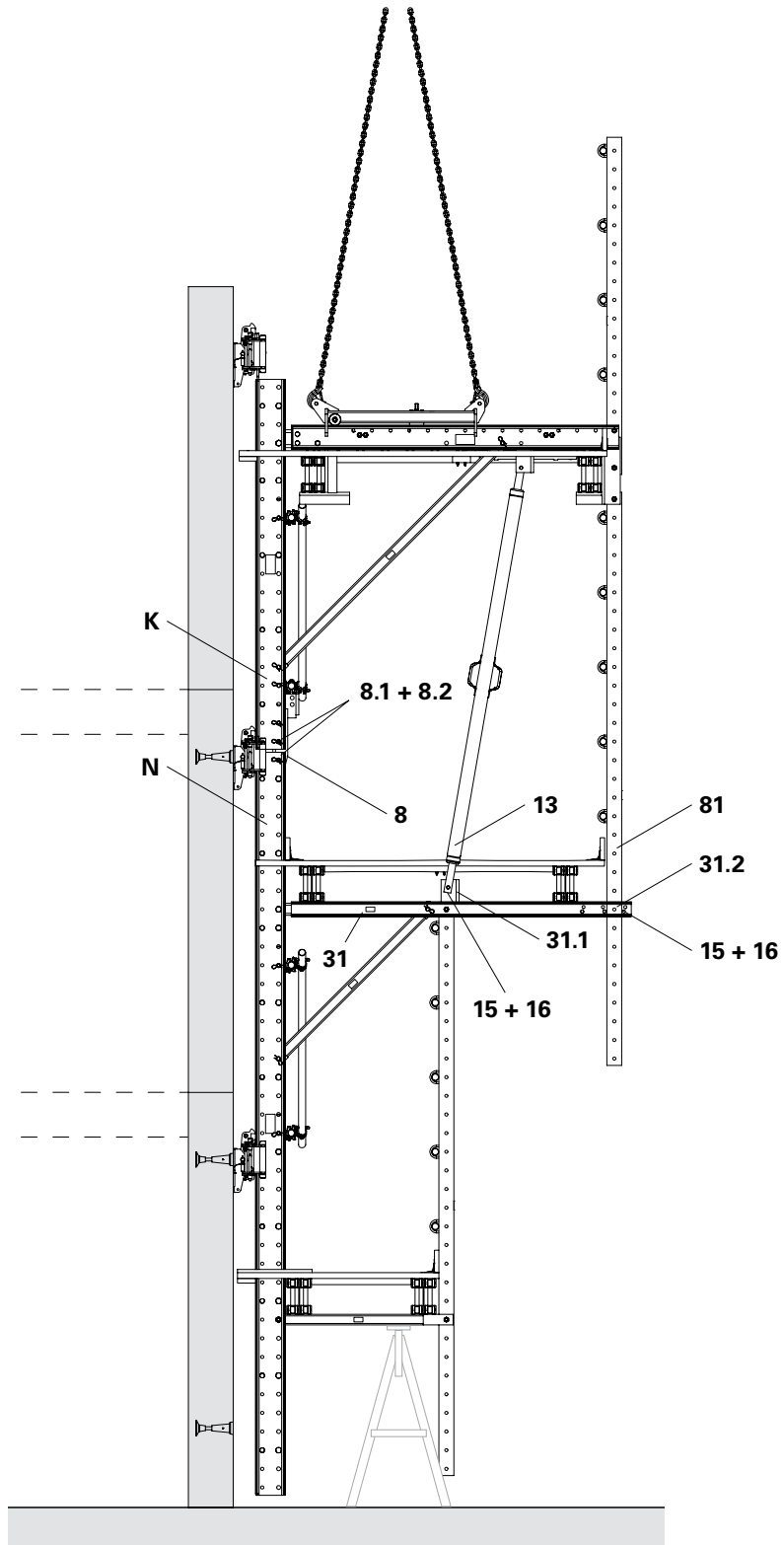

Fig. C4.18

Ladders



Do not use the ladder until it is securely attached at the top and bottom, and the Ladder Safety Cage has been mounted.

The required ladder elements are connected together according to project specifications.

Components

- 67** Ladder 180/6
- 68** Ladder 220/6
- 69** End Ladder 180/2
- 70** Ladder Base 30, adjustable
- 72** Ladder Safety Cage 75
- 73** Ladder Safety Cage 150
- 101** Bolt ISO 4017 M12 x 40-8.8
- 118** Nut ISO 7040 M12-8
- 127** TSS-Torx 6 x 40

Pre-assembly of ladder

- Permanently mounted ladders:
 1. Push top Ladder 220/6 (**68**) with the connector (**68.1**) as far as possible into the bottom Ladder 180/6 (**67**).
 2. Secure the bottom ladder to the connector using the 4x provided bolts M12 x 40 and nuts (**68.2**).
 3. Fix Ladder Base (**70**) to the connector (**67.1**) on the bottom ladder in the same way using 4x bolts M12 x 40 (**101**) and nuts.

(Fig. C5.01)

- Bottom ladder as hook-in ladder:
 1. Secure ladder hook (**71**) to the 2 bottom holes on the ladder rail using the 4x provided bolts M12 x 25 and nuts (**71.1**).
 2. Securely mount the Ladder Base (**70**). See above.
 3. Attach hook-in ladder to the top ladder.

(Fig. C5.02 + C5.03)

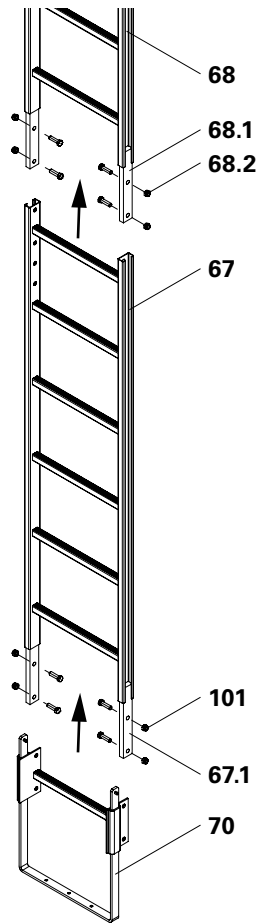

Fig. C5.01

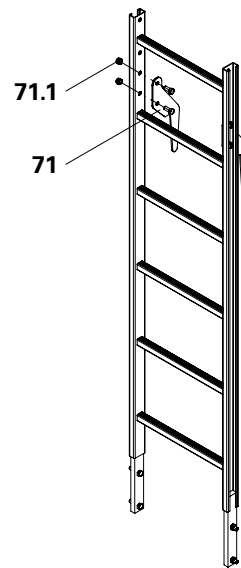

Fig. C5.02



The rungs of the hook-in ladder and top ladder must be positioned at the same height. If not, secure the ladder hooks using the correct drilled holes.

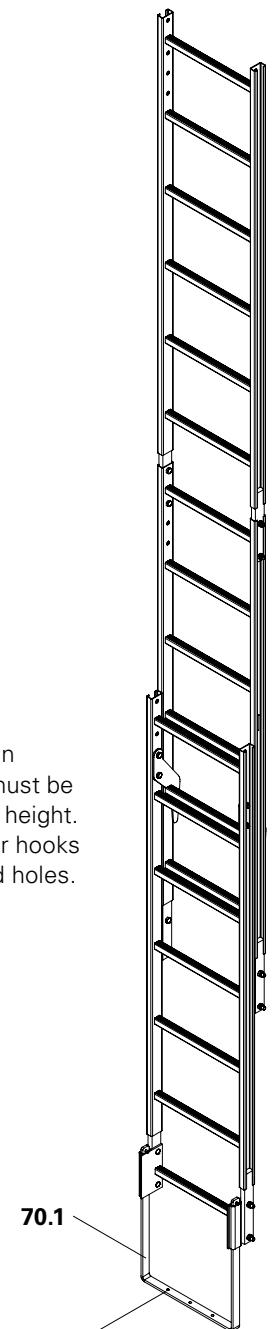

Fig. C5.03

Attaching the ladder to the hatch

1. Lift ladder using the crane. Lower ladder through hatch opening (66).
2. Fix ladder to the hatch from above using 2x bolts M12 x 40 and nuts (101 + 118).

(Fig. C5.04)

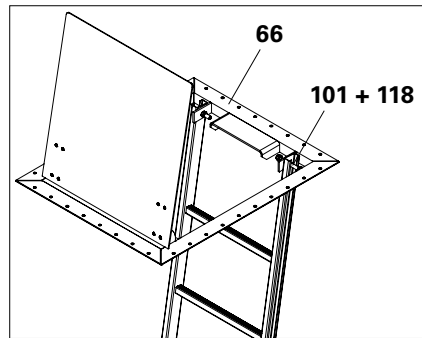

Fig. C5.04

Attaching the End Ladder 180/2

1. Open the hatch cover (66.1).
2. Lift pre-assembled ladders (67 + 69) with the crane into the hatch (66) and lower so that the top rung of the ladder lies in the U-profile of the hatch.

(Fig. C5.05)

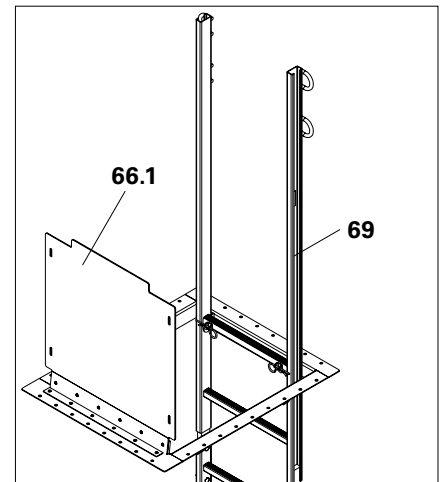

Fig. C5.05

Fixing the Ladder Base

1. Pull out the bracket (70.1) of the Ladder Base (70) as far as the platform decking. Secure bracket to the platform decking using 3x TSS Torx 6 x 40 (127).

Mounting the Ladder Safety Cage



- The distance from the platform decking to the Ladder Safety Cage ranges from 2.2 m to 3.0 m.
- The opening between two Ladder Safety Cages must not exceed 50 cm.

1. Bring and hold the Ladder Safety Cage (72) in position using a rope.
2. Slightly loosen bolts M12 x 25 (4x) on the clamping plate (72.1), position clamping plate on the ladder rail (68), turn and tighten bolts.

(Fig. C5.06)

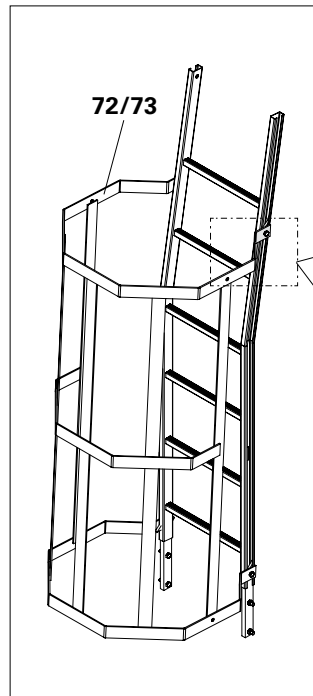
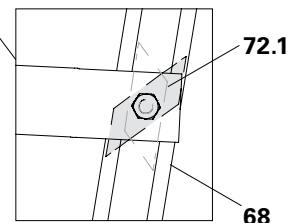
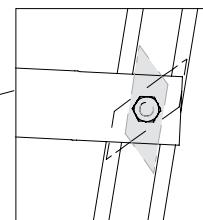

Fig. C5.06



- The ladder can, according to the criteria of DIN EN 131-2, be used with platform spacings of up to 7.0 m.
- Maximum inclination $\alpha < 15^\circ$.



For storey heights that are multiples of 50 cm, PERI recommends mounting an additional Spacer as a defined support in the Climbing Rails.

Components

50 Climbing Shoe RCS

Step 1 – Concreting

Concrete the wall and slab with anchored formwork.

The vertical loads are transferred through the middle Climbing Shoe (**50b**) into the building.

Climbing Shoe, Wall Shoe and Climbing Cone are functioning at the height of the finishing platform. (Fig. D1.01)

Step 2 – Striking

Release the mounting of the Leading Anchor and execute striking.

Remove the Wall and Climbing Shoe (**50c**) in the area of the finishing platform and mount in advance on the new concreting section (**50v**).

Remove anchoring, close the anchor hole if necessary.

Alternatively, the advanced Wall and Climbing Shoe can be mounted after climbing. (Fig. D1.02)

Step 3 – Self-Climbing

Use the Climbing Device on the middle Climbing Shoe (**50b**) and connect it to the Hydraulic Pump.

Climb in strokes of 50 cm.

In order to allow easier insertion: adjust the framework using the Framework Spindle.

Before the last lift: activate the climbing pawls on the top Climbing Shoe (**50a**).

After completing the climbing procedure, the advanced Climbing Shoe (**50v**) becomes the top Climbing Shoe (**50a**). (Fig. D1.03)

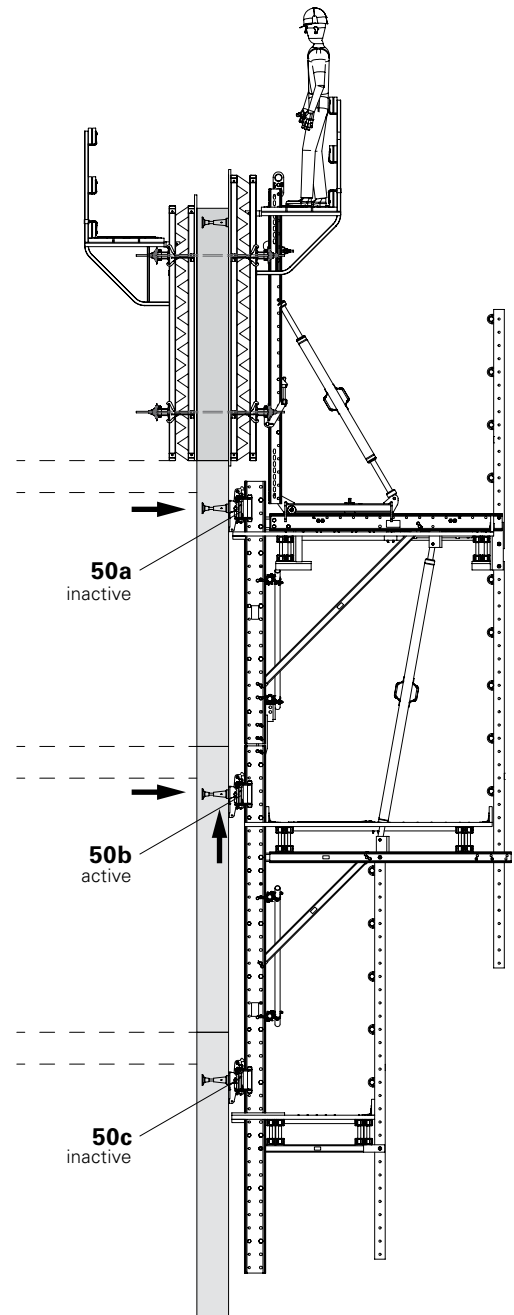

Fig. D1.01

Step 1

D1 Work Process in a Standard Cycle

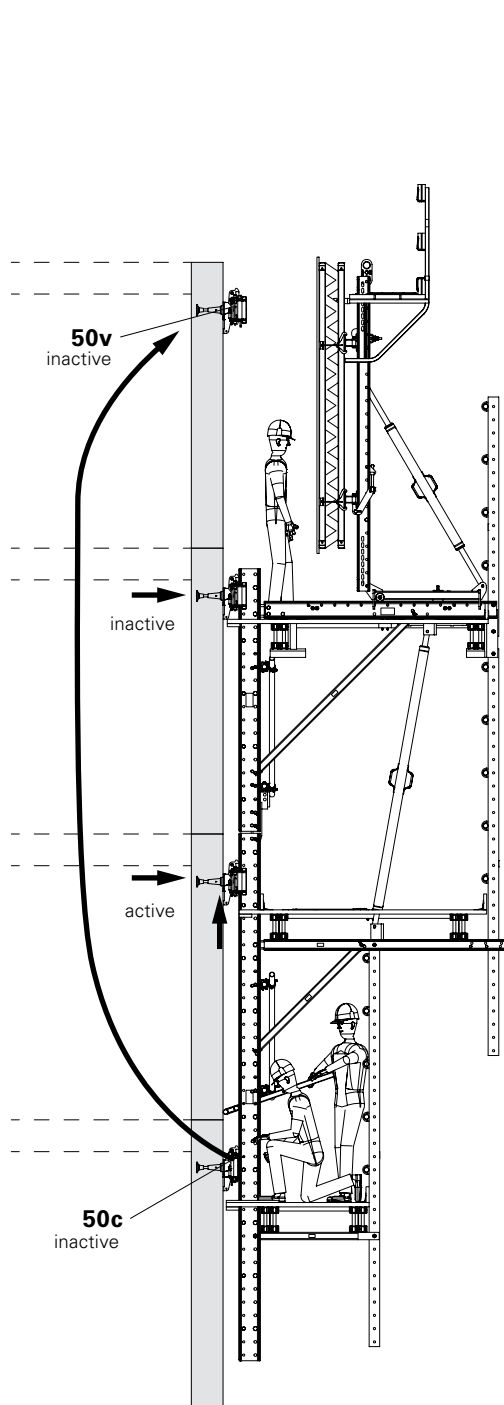

Fig. D1.02

Step 2

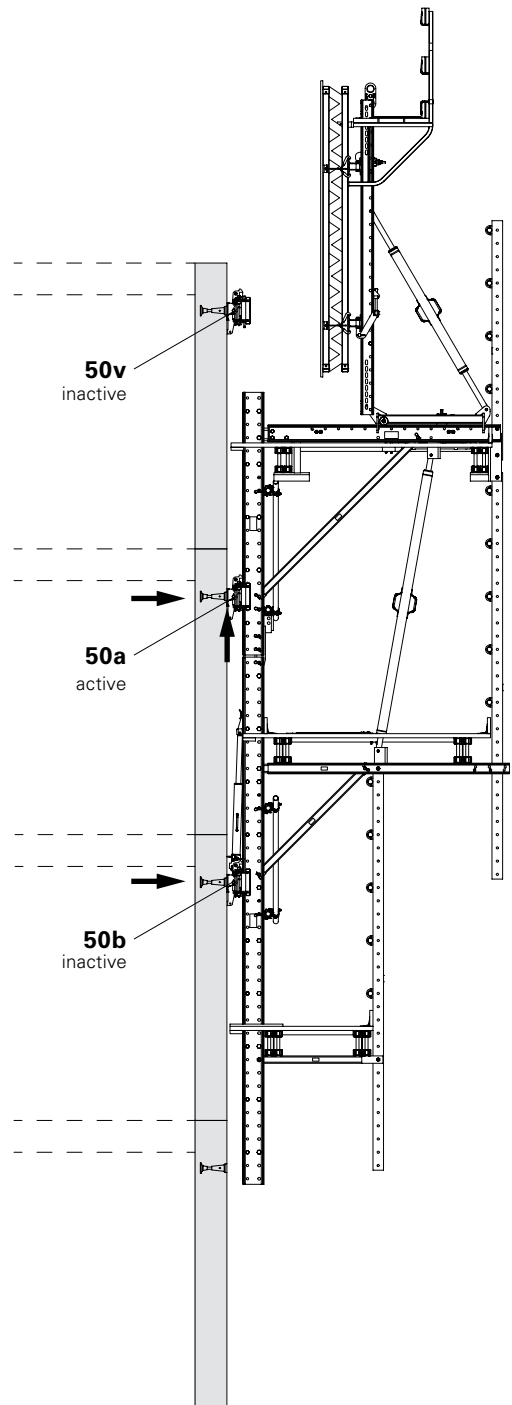

Fig. D1.03

Step 3

Step 3 – Alternatively: Climbing with the Crane

Climbing pawl of the advanced Climbing Shoe (50v) is deactivated. Activate the climbing pawl of the top Climbing Shoe (50a).

Attach the crane lifting gear to the Climbing rail; site personnel are to leave the climbing unit.

In order to allow easier insertion: before the last stroke, adjust the framework using the Framework Spindle.

Lift the climbing unit into the advanced Climbing Shoe (50v) and place on the top Climbing Shoe (50a) with the planned Spacer. (Fig. D1.04)

After completing the climbing procedure, the advanced Climbing Shoe (50v) becomes the top Climbing Shoe (50a).

Step 4 – Aligning the Climbing Unit

Remove climbing hydraulics or detach crane lifting gear.

Adjust framework using the Framework Spindle.

→ The horizontal load is transferred. (Fig. D1.05)

Step 5 – Shuttering

Fix the Leading Anchor to the formwork.

Move the Carriage to the wall.

Adjust formwork.

Install reinforcement.

Place the internal formwork and anchor against the external formwork.

Concrete the wall.

The protruding wall formwork serves as stopend formwork for the slab. (Fig. D1.06)

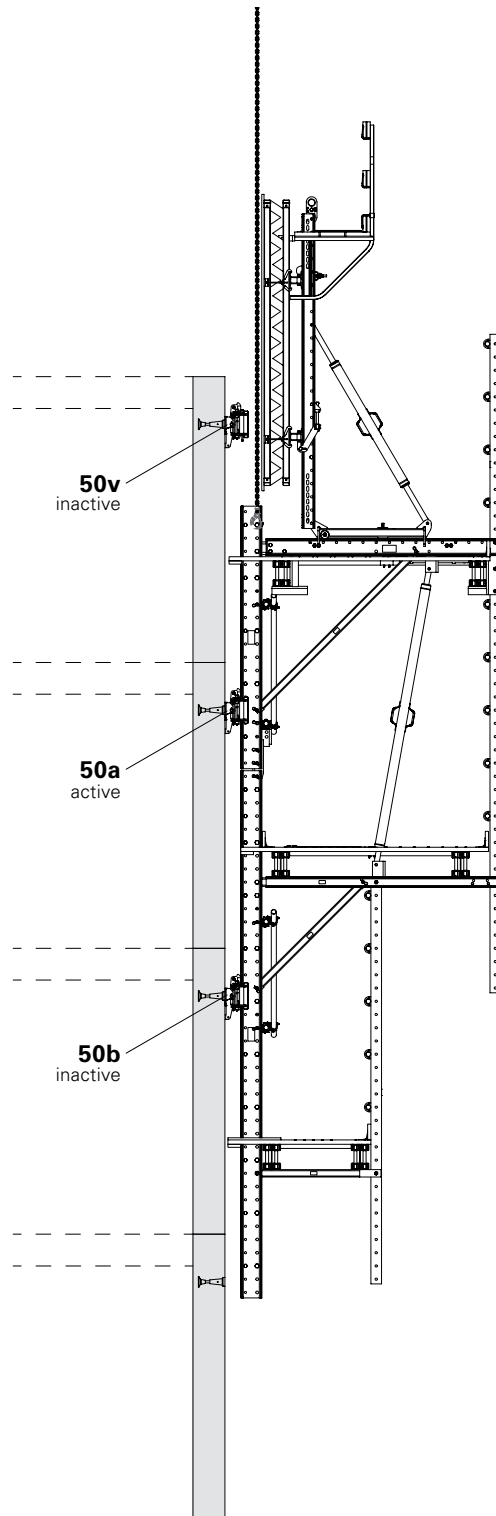

Fig. D1.04

Step 3 – Alternative

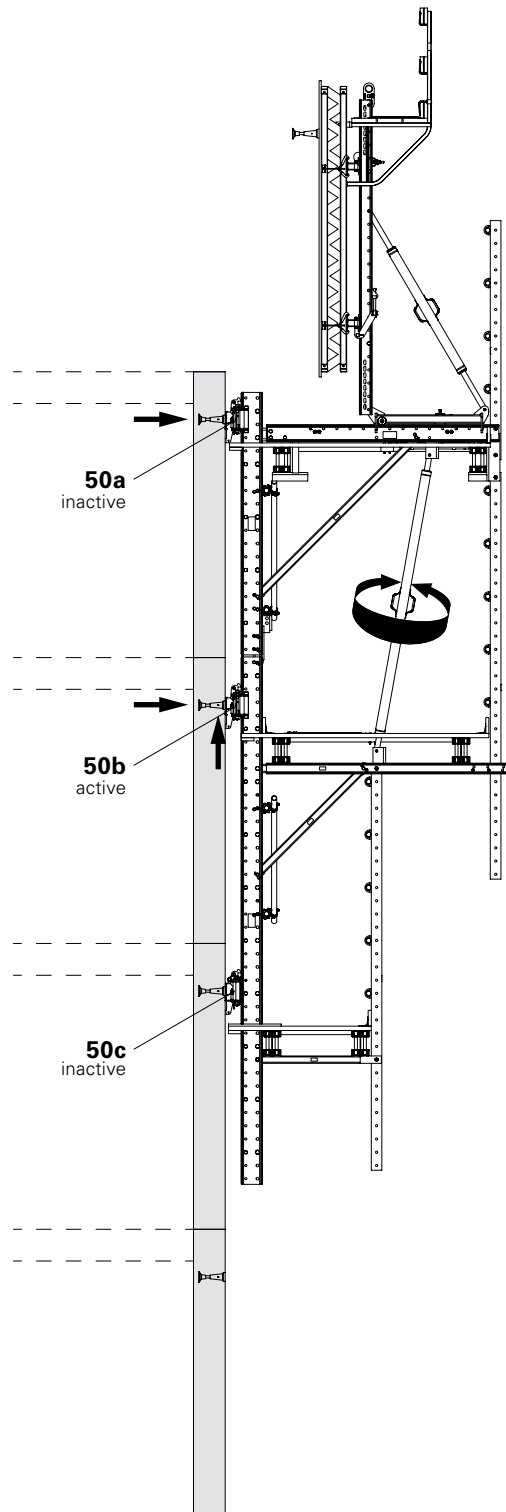

Fig. D1.05

Step 4

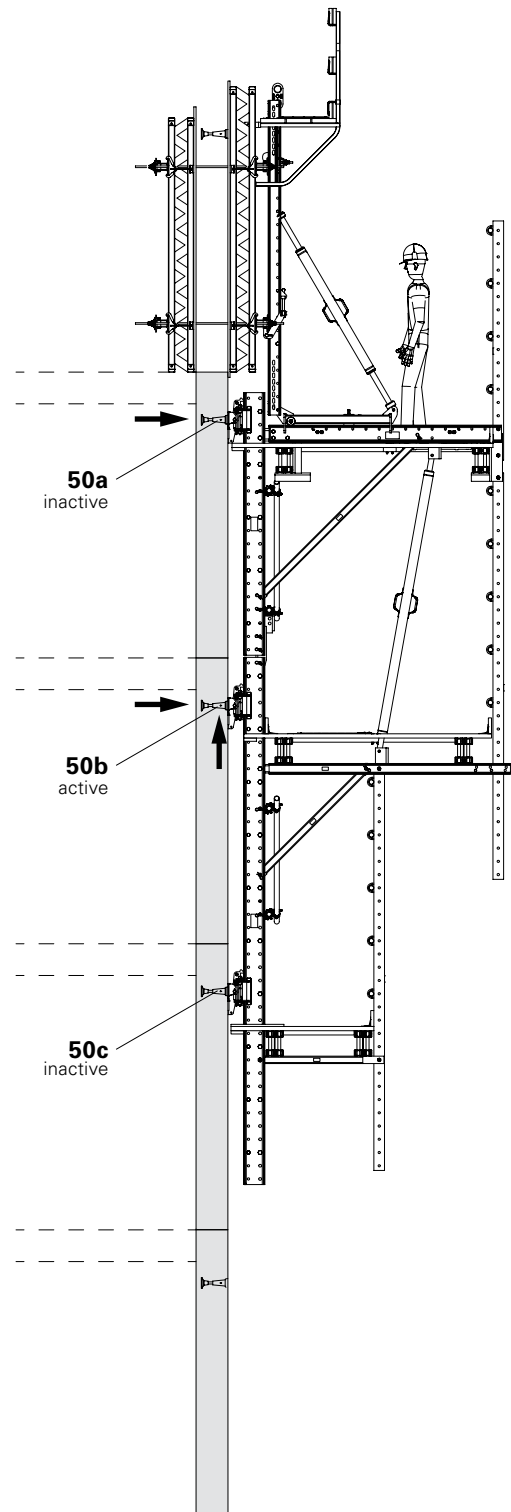

Fig. D1.06

Step 5

Operating the Carriage

Components

24 Carriage RCS

1. Turn the Traction Screw (**24.3**) using the Carriage Wrench SW 19 (**24.4**) and thereby move the Carriage (**24**) towards or away from the wall.
 - The maximum moving distance is approx. 90 cm.
 - Operate both Carriages simultaneously on one platform.

(Fig. D2.01)



Have all Advancing Bolts, formwork anchors and connections to the formwork elements of the neighbouring platforms been released?

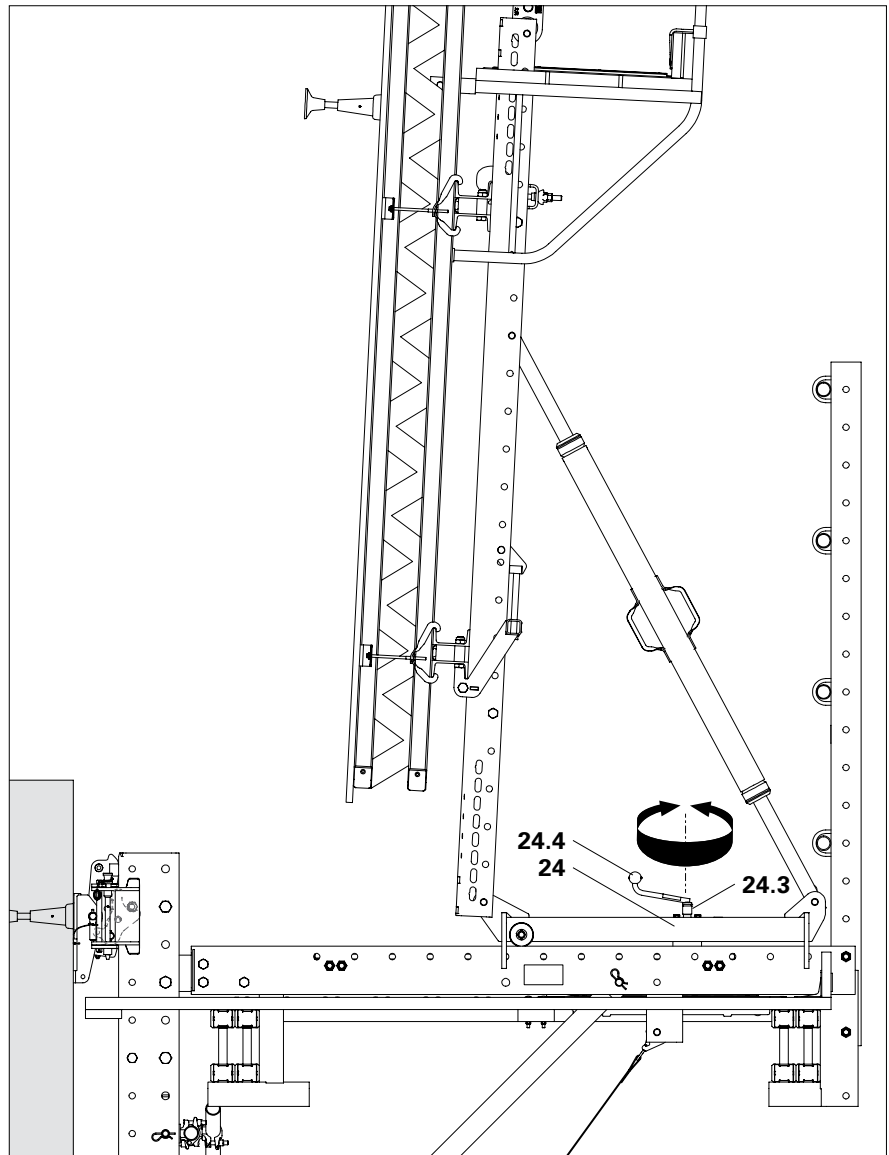

Fig. D2.01

Adjusting the Formwork

Components

- 25** Steel Waler Universal SRU L = 2.72
- 26** Waler Fixation U100 - U120
- 27** Adjusting Unit SRU, external
- 28** Heavy-Duty Spindle SLS 200/300

Placing in a vertical position

1. Hold a spirit level against the formwork and vertically adjust the formwork by turning the Formwork Spindle (**28**). (Fig. D2.02)



Is the formwork positioned right up against the wall?

Adjusting the height:

1. Slightly loosen the Waler Fixation (**26**).
2. Set the formwork to the exact height by turning the Adjusting Unit (**27**).
3. Tighten the Waler Fixation.

Moving horizontally:

1. Slightly loosen the Waler Fixation (**26**).
2. Move the formwork against the Strongback (**25**) by means of the lever.
3. Tighten the Waler Fixation.

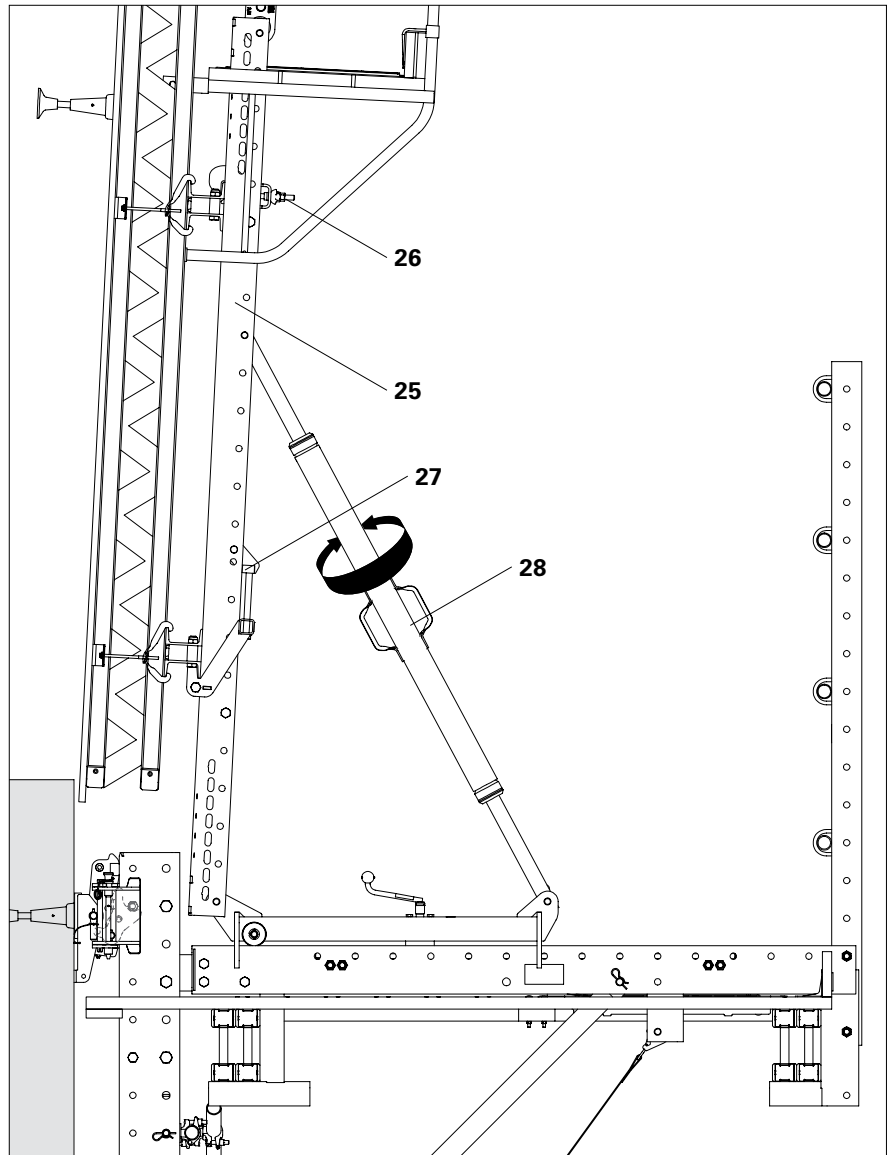

Fig. D2.02

Adjusting the Lattice Framework

Components

- 1 Top Climbing Rail RCS
- 2 Bottom Climbing Rail RCS
- 13 Heavy-Duty Spindle SLS 260/360

The inclination of the top Climbing Rail (1) can be adjusted relative to the bottom Climbing Rail (2). For this, turn the Framework Spindle (13).

- As a result, the lower Climbing Shoe is relieved and can then be removed.
- The Climbing Rail can be easily inserted into the next Climbing Shoe when climbing.
- Wall projections or wall recesses can be climbed over.



- Maximum inclination between the Wall Shoe and Climbing Shoe $\alpha \leq 4^\circ$.
- Depending on the Climbing Rail and floor configuration, wall offsets of ± 100 mm are possible.

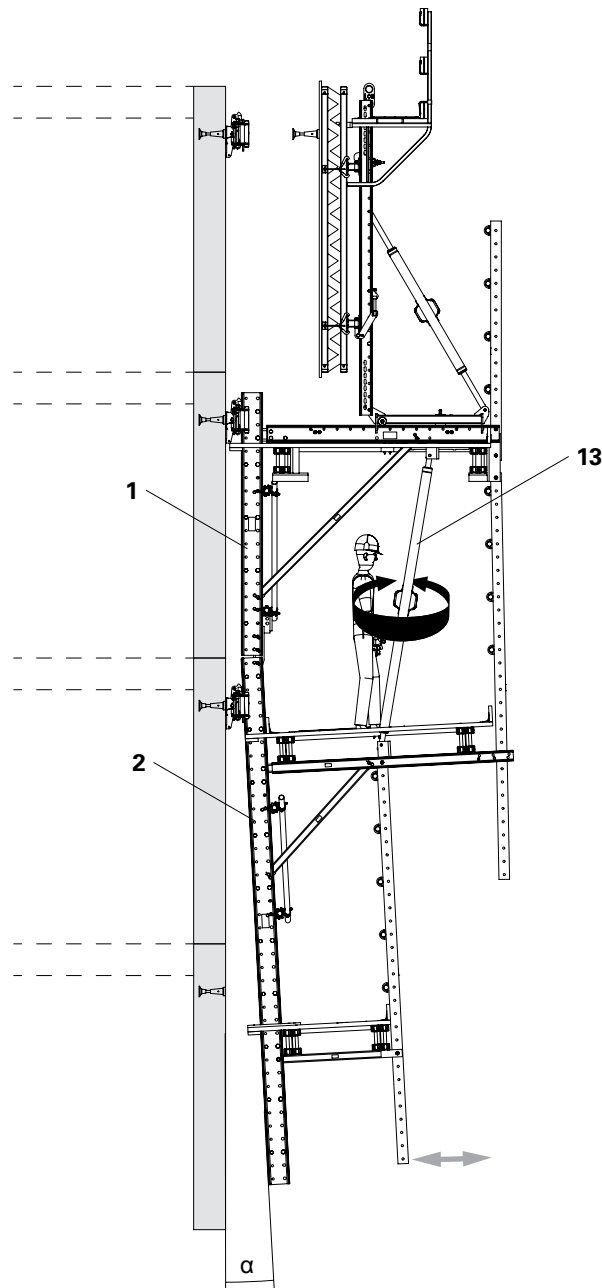

Fig. D2.03

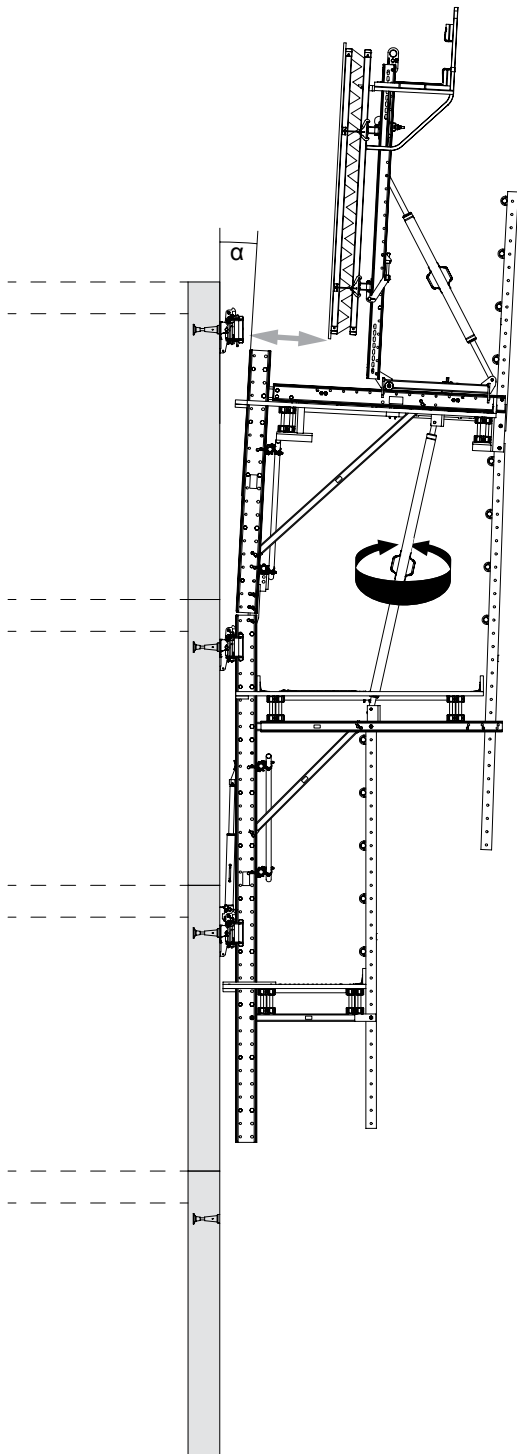

Fig. D2.03a

Releasing the Leading Anchor

Components

42.1 Advancing Bolt

42.2 Anchor Positioning Stud M30

Preparation

Remove all connections, e.g. couplings, from the formwork elements of the adjacent climbing units.

Standard: Advancing Bolt

Dismantling

1. Release Advancing Bolts M30 (**42.1**) and remove.
2. Release the formwork away from the wall using the Heavy-Duty Spindle.
3. Strike formwork with the carriage, see Section "D2 Operating the Formwork" on page 102.

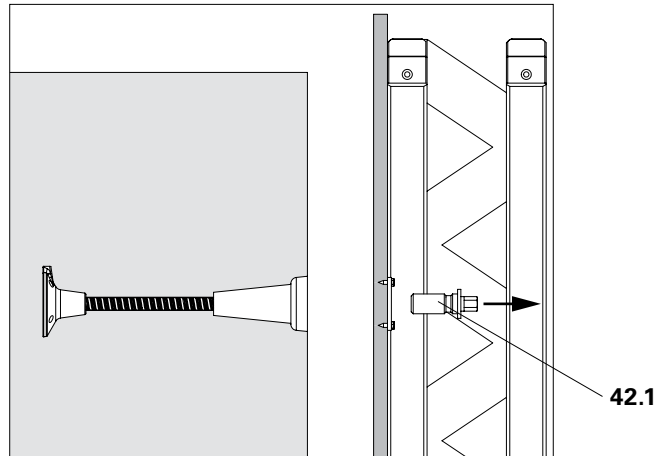

Fig. D3.01

Alternatively: Anchor Positioning Stud

Dismantling

1. Straighten wire nails $\text{Ø } 3 \times 80$ (**143**).
2. Release the formwork from the wall using the Heavy-Duty Spindle.
→ Pull wire nails $\text{Ø } 3 \times 80$ (**143**) out of the formlining.
3. Strike formwork with the Carriage.
4. Bend wire nails $\text{Ø } 3 \times 80$ (**143**) to one side in order to protect hands.
5. Remove Anchor Positioning Stud M30 (**42.2**) using an Allen key SW 14.

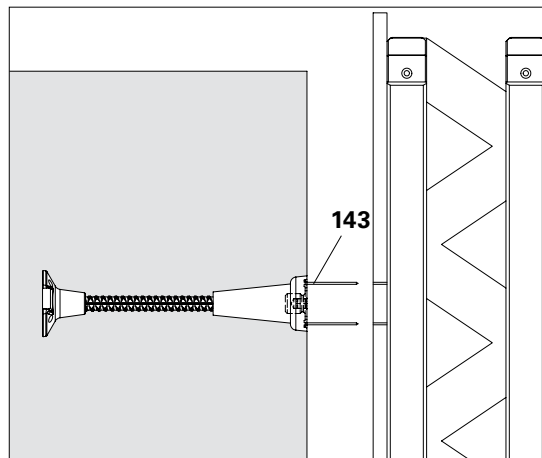

Fig. D3.02

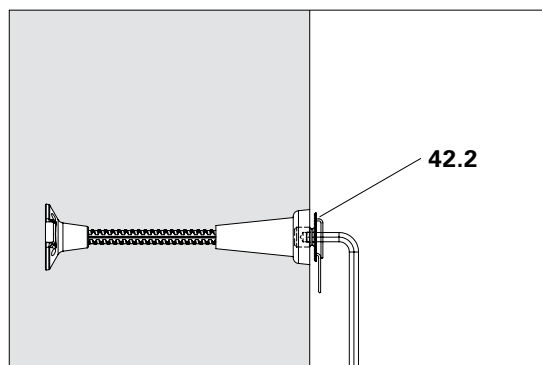

Fig. D3.03

Assembling the Suspension

Components

- 47** Anchoring
- 50** Climbing Shoe RCS
- 51** Wall Shoe RCS

Assembling the Wall Shoe

1. Remove cotter pins (**51.3**) from the fitting pins and remove fitting pins (**51.1**) from the Wall Shoe RCS.
2. Insert cotter pins into the fitting pins.
3. Fix the Wall Shoe RCS to the anchoring (**47**) using a hex. bolt M30x70-8.8 (**51.2**).
Tightening torque 260 Nm.



Has the bolt been tightened?

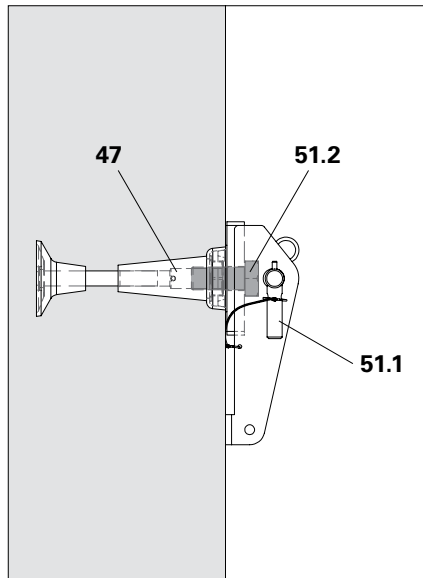

Fig. D4.01

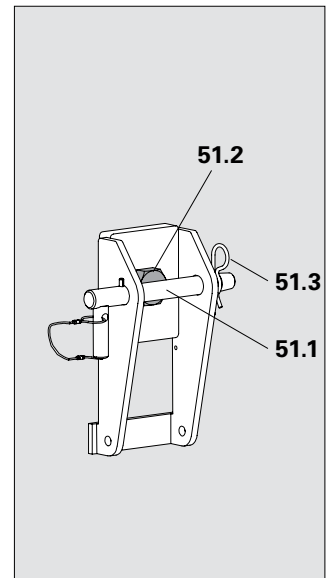

Fig. D4.01a

Assembling the Climbing Shoe

1. Put the Climbing Shoe RCS (**50**) in the Wall Shoe RCS (**51**).
2. Insert the fitting pin (**51.1**) through the cheeks of the Wall Shoe and Climbing Shoe and secure with the cotter pin (**51.3**).
3. Depending on the situation, deactivate or activate the climbing pawl (**50.1**) in the Climbing Shoe or open or close the guiding skids (**50.2**).
See Section "D5 Operating the Climbing Shoe" on page 112.



- Are all fitting pins (**50.3**) on the guide skids fully inserted in a downwards direction?
- Are the fitting pins (**51.1**) secured with cotter pins?
- Is the Climbing Shoe exactly vertical?

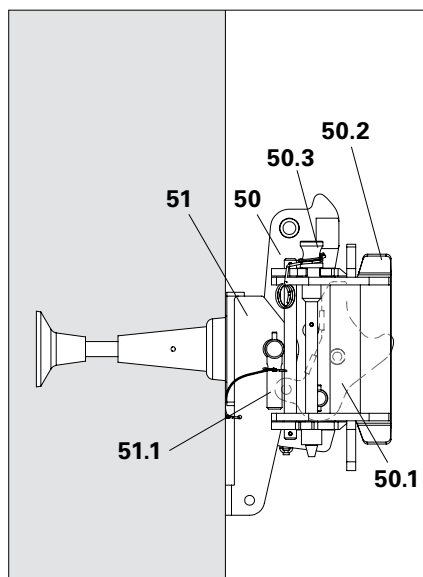

Fig. D4.02

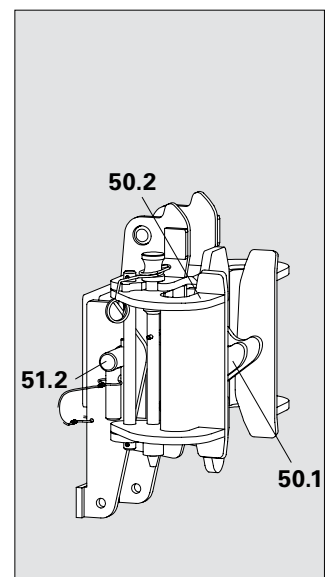

Fig. D4.02a

Dismantling the Suspension

Components

- 2** Bottom Climbing Rail RCS
- 50** Climbing Shoe RCS
- 51** Wall Shoe RCS
- 54** Excentric Lever RCS



Warning

- During assembly on the construction site, components may fall to the ground and hit people below! This could lead to serious injuries or even death.
 - Secure all components, e.g. with ropes.
 - Cordon off areas of risk under the working areas.
- Climbing Rail can jump back! As a result, body parts could become trapped and severely injured.
 - Ensure that the Excentric Lever is sufficiently fixed in position through the friction.
 - Excentric Lever is held by a second person.
 - Keep hands away from all clamping points.

Dismantling

1. From the side, place the Excentric Lever RCS (**54**) between the wall and bottom Climbing Rail (**2**).
 - In order that the Climbing Shoe can be removed, a distance of at least 50 cm to the Wall Shoe is required.
 2. Push the Climbing Rail away from the wall with the Excentric Lever until the fitting pin (**51.1**) in the Wall Shoe is released. Ensure that the Excentric Lever is firmly held in place by a second person during the entire assembly.
 - The Climbing Shoe is now relieved.
- Alternatively:
- Adjust latticed framework so that bottom Climbing Shoe is then freed. See Section "Adjusting the Latticed Framework" on page 104.

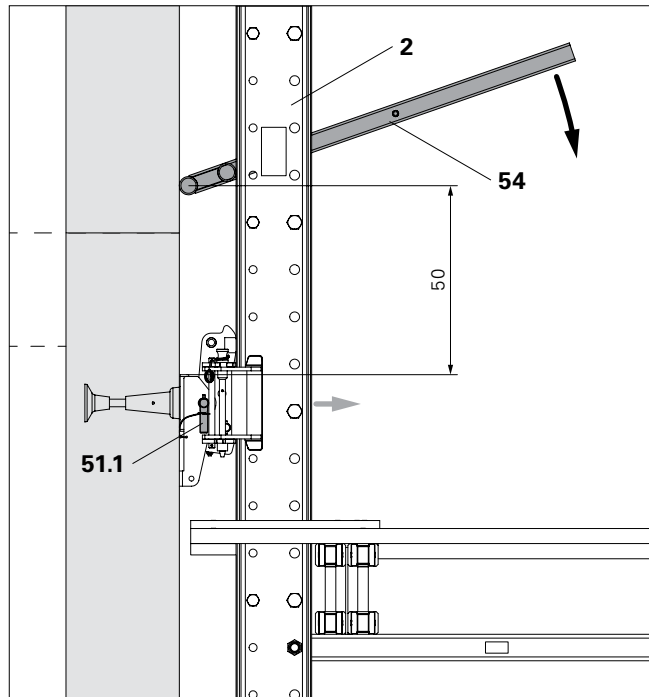

Fig. D4.03

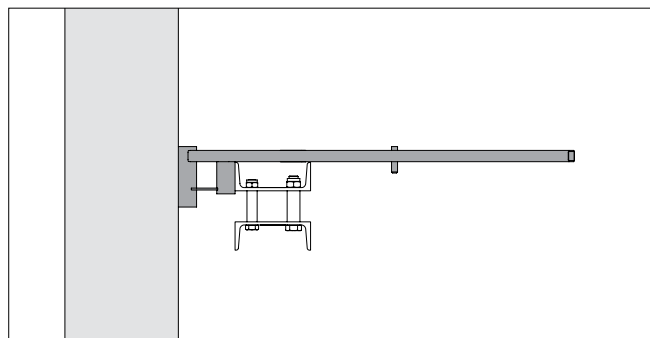

Fig. D4.03a

Top view

3. Open both guiding skids (**50.2**).
4. Deactivate the climbing pawl in the Climbing Shoe. See Section "D5 Operating the Climbing Shoe" on page 112.
5. Hold the Climbing Shoe (**50**) and remove the fitting pin (**51.1**) from the Wall Shoe RCS (**51**).
6. Move the Climbing Shoe upwards and then sideways behind the Climbing Rail.
7. Re-attach fitting pins and cotter pins. Hold the Wall Shoe and screw out the hex. bolt M30x70-8.8 (**51.2**).
8. Pull Wall Shoe RCS out sideways behind the Climbing Rail.
9. Important! The Excentric Lever (**54**) jumps upwards when lifting. Carefully lift the Excentric Lever until the Climbing Rail is freed.

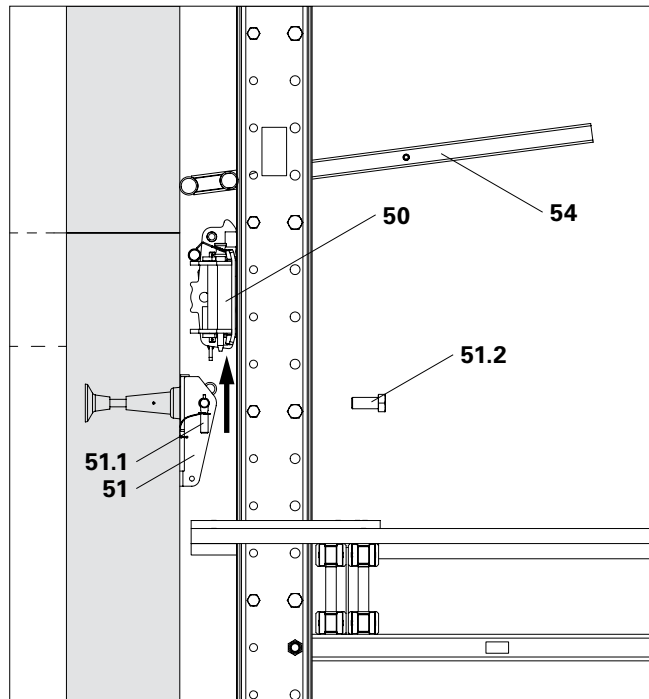

Fig. D4.04

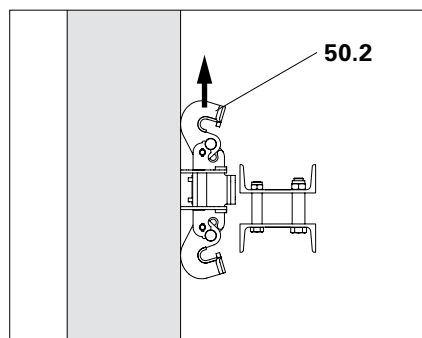

Fig. D4.04a

Top view

Removing the Climbing Cones

Components

- 47.1** Climbing Cone-2 M30/DW 26
- 47.5** Climbing Cone-2 M30/DW 20

Dismantling

1. Loosen the reusable part of the anchoring with a SW 46 ring spanner and remove completely:
 - Climbing Cone-2 M30/DW 20 (**47.5**)
 - Screw-On Cone-2 M30/DW 26 (**47.1**)



- If necessary: create a watertight seal of the anchor hole with KK Concrete Cone M30-80/52 (**47.9**) and PERI sealing compound.
 - See User Information for Concrete Cones with Sealing Compound-3.

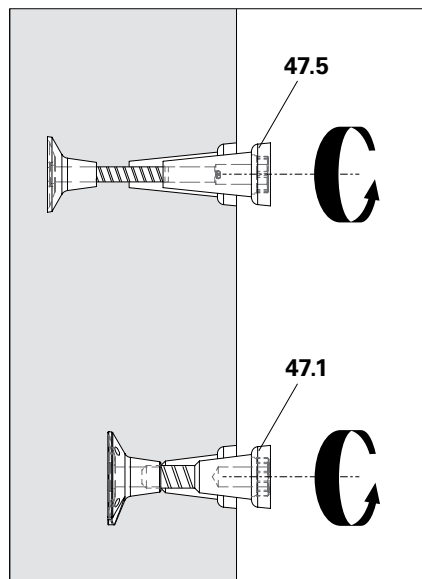

Fig. D4.05

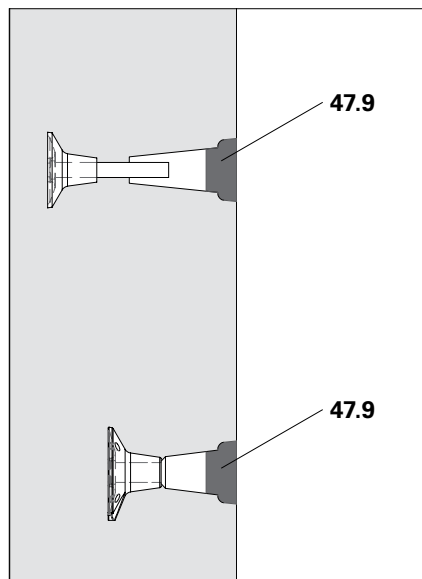

Fig. D4.06

Opening and Closing the Climbing Shoe

The securing pins (50.3) hold the guiding skids (50.2) in a closed position. (Fig. D5.01 + D5.01a)

Components

- 50 Climbing Shoe RCS
- 50.2 Guiding Skids
- 50.3 Securing Pin
- 50.6 Locking Spring

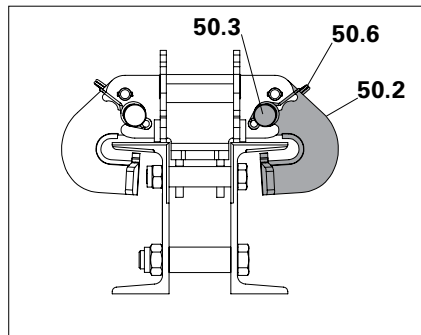

Fig. D5.01

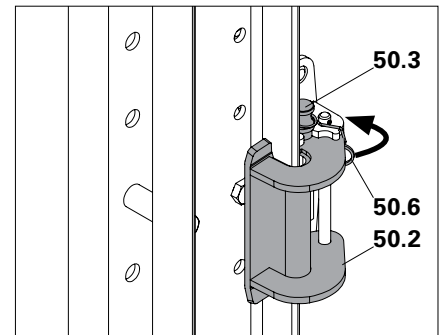

Fig. D5.01a

Opening the Climbing Shoe

1. Release the locking spring (50.6).
For this, pull the ring out from under the guiding skid (50.2).
(Fig. D5.01 + D5.01a)
2. Lift the securing pin (50.3).
3. Fold out the guiding skids (50.2).
(Fig. D5.02 + D5.02a)
4. Re-insert securing pin (50.3) in the opened position; place the locking spring (50.6) only loosely on the guiding skid.
(Fig. D5.03 + D5.03a)
5. Proceed in the same way with the other guiding skid.
(Not shown)

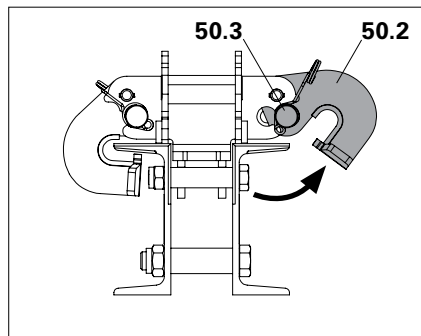

Fig. D5.02

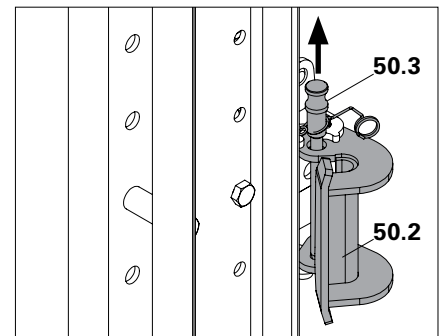

Fig. D5.02a



Opening the guiding skids facilitates insertion of the Climbing Rail during climbing and allows the Climbing Rail to be inserted during initial assembly.



Danger

Do not open the guiding skids of any Climbing Shoe that is under load / supporting the Rail.

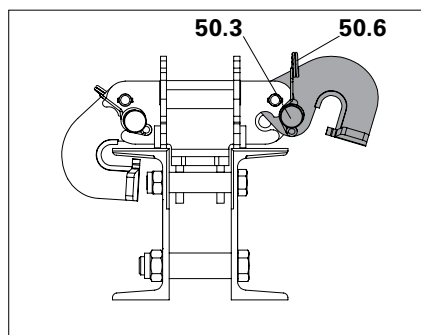

Fig. D5.03

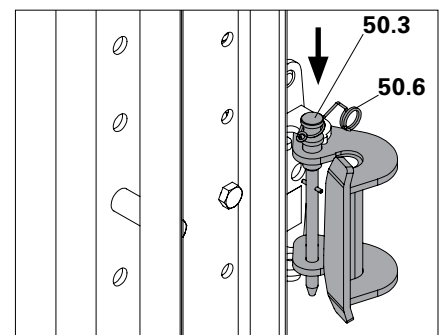

Fig. D5.03a

D5 Operating the Climbing Shoe

Closing the Climbing Shoe

1. Lift the securing pin (50.3).
(Fig. D5.04 + D5.04a)
2. Fold the guiding skid (50.2)
forwards. (Fig. D5.05 + D5.05a)
3. Fully re-insert the securing pin (50.3)
in the closed position.
4. Fix the locking spring (50.6). For this,
the ring is snapped into place under
the guiding skid (50.2).
5. Proceed in the same way with the
other guiding skid.

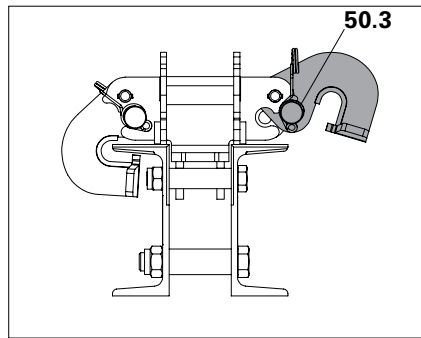

Fig. D5.04

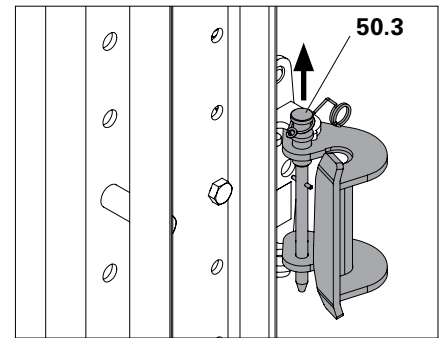

Fig. D5.04a



Are both locking pins completely inserted and is the locking spring fixed in position?

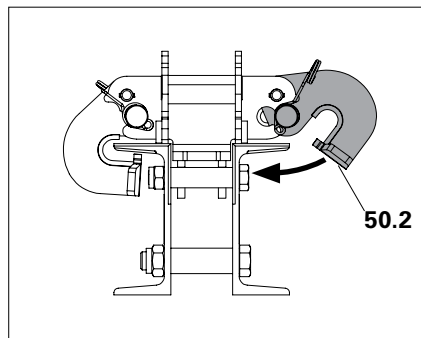

Fig. D5.05

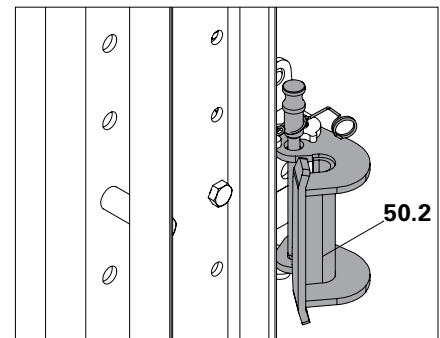

Fig. D5.05a

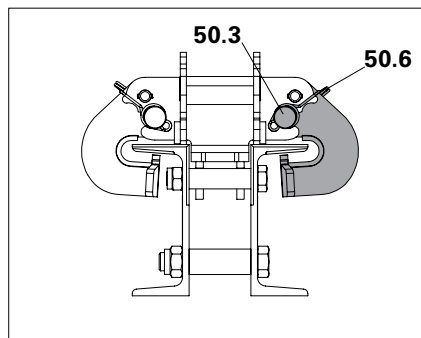

Fig. D5.06

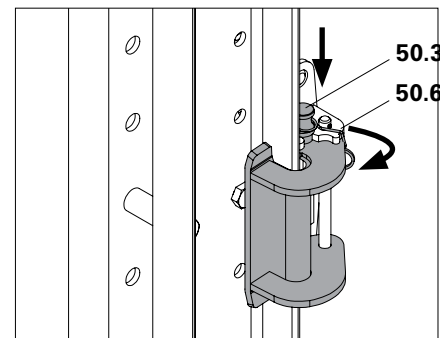

Fig. D5.06a

Activating / Deactivating the Climbing Pawl



Warning

Hands can get caught between the Climbing Rail and Climbing Shoe and become trapped!

This can cause serious injuries.

- ⇒ Only activate or deactivate the climbing pawl when the climbing unit has stopped moving.
- ⇒ Do not reach into the Climbing Rail during the climbing procedure.

Components

- 50** Climbing Shoe RCS
- 50.1** Climbing Pawl
- 50.4** Pawl Locking Mechanism
- 50.5** Hinged Bail

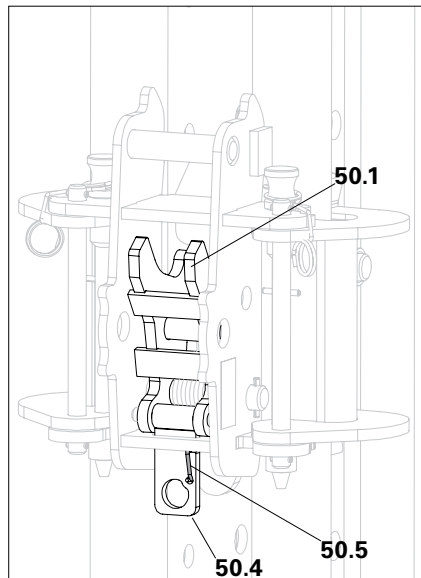

Fig. D5.07

Deactivating the climbing pawl

1. Ensure that the climbing unit is stationary.
 2. Pull down the pawl locking mechanism (50.4) on the Climbing Shoe.
 3. Fold the hinged bail (50.5) upwards on the pawl locking mechanism and then let go of the pawl locking mechanism.
 - The hinged bail is then clamped and blocks the pawl locking mechanism.
 - The climbing pawl (50.1) is deactivated and thus non-operational.
- (Fig. D5.07 + D5.07a)



In this position, no vertical forces from the Climbing Rail can be transferred via this particular shoe.

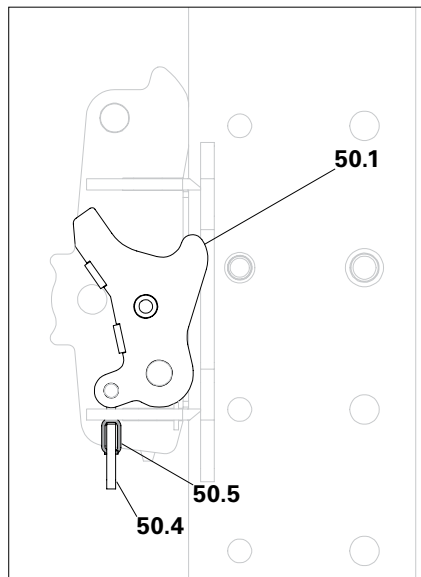

Fig. D5.07a

Activating the climbing pawl

1. Ensure that the climbing unit is stationary.
 2. Pull down the pawl locking mechanism (50.4) on the Climbing Shoe.
 3. Fold up the hinged bail (50.5) on the pawl lock (5.4) and then let go of the pawl locking mechanism.
 - The climbing pawl (50.1) jumps into its working position.
 - The climbing pawl is activated and therefore operational.
- (Fig. D5.08 + D5.08a)



Can the climbing pawl move freely?
Is the hinged bail hanging downwards?



- This position serves the purpose of transferring vertical forces from the Climbing Rail during working operations and climbing.
- For storey heights that are roughly divisible by 50 cm, only activate the pawls on the Climbing Shoes that serve as the planned vertical support. Deactivate all other Climbing Shoes.

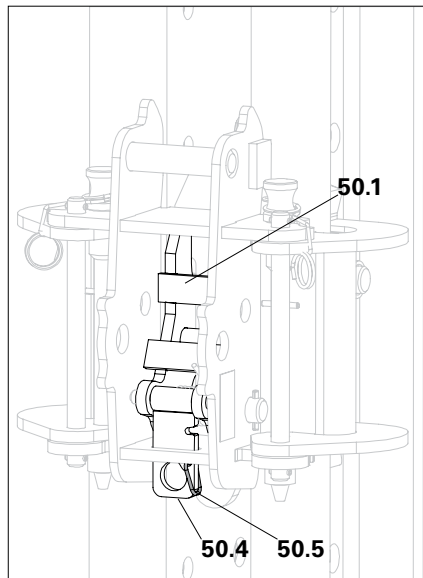

Fig. D5.08

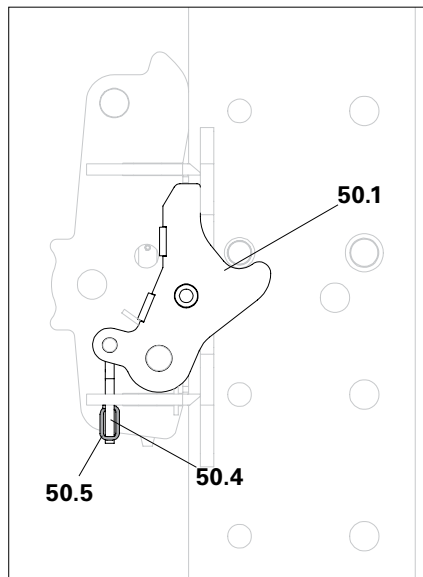

Fig. D5.08a

D5 Operating the climbing shoe (With Climbing Shoe Display RCS)

Activating and deactivating the climbing pawl

Warning

Hands can become trapped between climbing rails and climbing shoes! This can result in serious injuries.

- ⇒ Only activate or deactivate the climbing pawl when the climbing unit has stopped moving.
- ⇒ Do not reach into the climbing rail during the climbing procedure.

Components

- 50** Climbing Shoe RCS
- 50.1** Climbing pawl
- 50.9** Climbing Shoe Display RCS

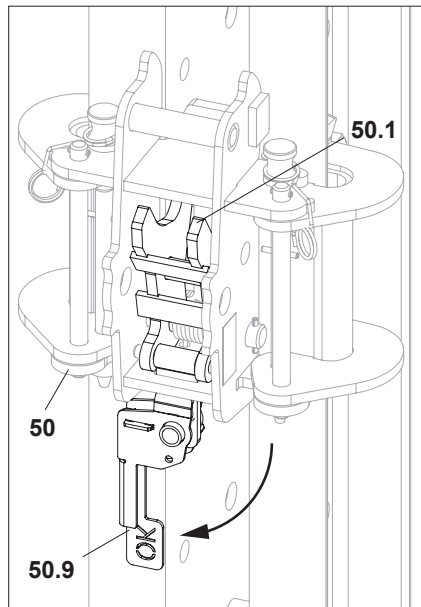

Fig. D5.09

Deactivating the climbing pawl

1. Ensure that the climbing unit is stationary.
2. Swing the Climbing Shoe Display RCS (**50.9**) on the Climbing Shoe RCS (**50**) downwards until it engages in a vertical position.
 - The climbing pawl (**50.1**) is deactivated and therefore non-operational.

(Fig. D5.09 + D5.09a)



- In this position, no vertical forces from the climbing rail or from the drive rail can be transferred via this particular shoe.
- Deactivating the climbing pawl prevents unintentional engagement with the pins of the climbing rail.

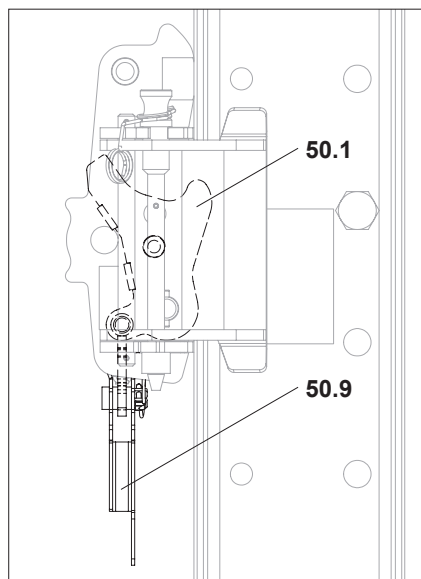

Fig. D5.09a

D5 Operating the climbing shoe (With Climbing Shoe Display RCS)

Activating the climbing pawl

1. Ensure that the climbing unit is stationary.
2. Swing the Climbing Shoe Display RCS (50.9) on the Climbing Shoe RCS (50) upwards.
→ The climbing pawl (50.1) is activated and therefore operational.
(Fig. D5.10 + D5.10a)



- Can the climbing pawl (50.1) move freely?
- Is the Climbing Shoe Display RCS (50.9) suspended horizontally?



This position serves the purpose of transferring vertical forces from the climbing rail during working operations and climbing.

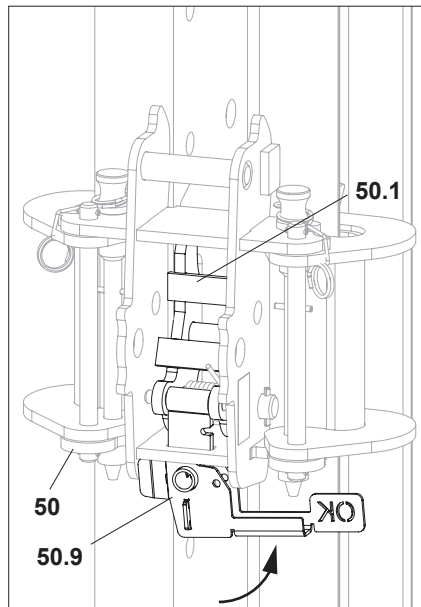

Fig. D5.10

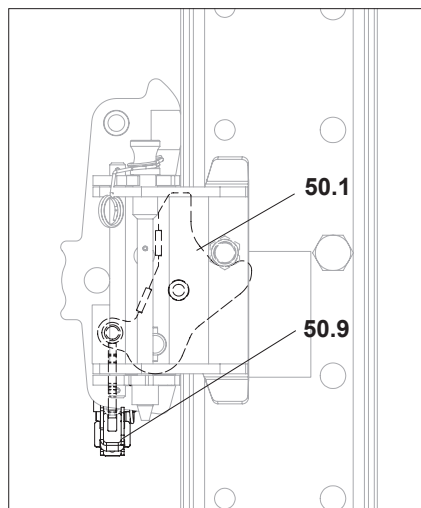

Fig. D5.10a

Safety Instructions



Warning

- There is a risk of falling from unsecured slab edges!
- As a result of the moving procedure, falling edges are formed between the platforms!

A fall can result in serious injury or even death!

- ⇒ Mount guardrails before climbing.
- ⇒ Areas of risk are to be cordoned off in advance.
- ⇒ Use personal protective equipment to prevent falls.



Warning

Parts of the body can get caught between the Climbing Rail and Climbing Shoe and become trapped!

This can cause serious injuries.

- ⇒ Do not take hold of the Climbing Shoe and Climbing Rails while the climbing formwork is being moved.



Warning

Climbing with crane can lead to unwanted movements of the climbing unit, e.g. due to an operating error!

This can cause serious injuries.

- ⇒ Only access the climbing unit if manual intervention is required.
- ⇒ Put the full weight of the climbing unit on the climbing shoes every time before accessing.
- ⇒ Before accessing the climbing unit, consult the operating and crane personnel.



- The load-carrying capacity of the structural elements, which carry the load-bearing Climbing Shoes, must be ensured.
- Do not transport persons, building materials or tools when moving with the crane. These could fall off, leading to serious injury or even death.
- Materials or other components must not protrude beyond the edge of the building. These could hinder the climbing procedure, or fall off.
- In the event of a malfunction, the climbing unit is to be set down in the next possible position and an authorised person is to be informed immediately.
- When climbing with the crane, always provide safe access for attaching and detaching the crane lifting gear. Additional double crane slings that remain on the climbing formwork may be necessary until they can be safely removed.
- Permissible total weight of the climbing unit
 - when attached to the Climbing Rail with Crane Eye BR-2 2.5 t (8), total max. 5 t.
 - when directly attached to the Spacer in the Climbing Rail RCS max. 10 t.

Preparations

Components

- 13** Framework Spindle
- 24** Formwork Carriage
- 50** Climbing Shoe RCS

The load rests on the middle Climbing Shoe (**50b**).

Assembly

1. Release formwork anchor and the mounting of Leading Anchor. See Section "Releasing the Leading Anchor" on page 106.
2. Remove the connections between the climbing units.
3. Retract Carriage (**24**). See Section "Operating the Carriage" on page 102.
4. Remove the Wall and Climbing Shoe (**50c**) in the area of the finishing platform and mount in advance on the new concreting section. (**50v**) (Fig. D6.01)
5. On the advanced Climbing Shoe (**50v**), deactivate the climbing pawl and open the guiding skids.
6. Activate the climbing pawl of the top Climbing Shoe (**50a**).
7. Remove anchoring, close the anchor hole if necessary.
Alternatively, the advanced Wall and Climbing Shoe can be mounted after climbing.
8. In order to allow easier insertion: adjust the framework using the Framework Spindle (**13**).
9. Attach the crane lifting gear to the Climbing Rail from a safe position; site personnel are to leave the climbing unit and area of risk.

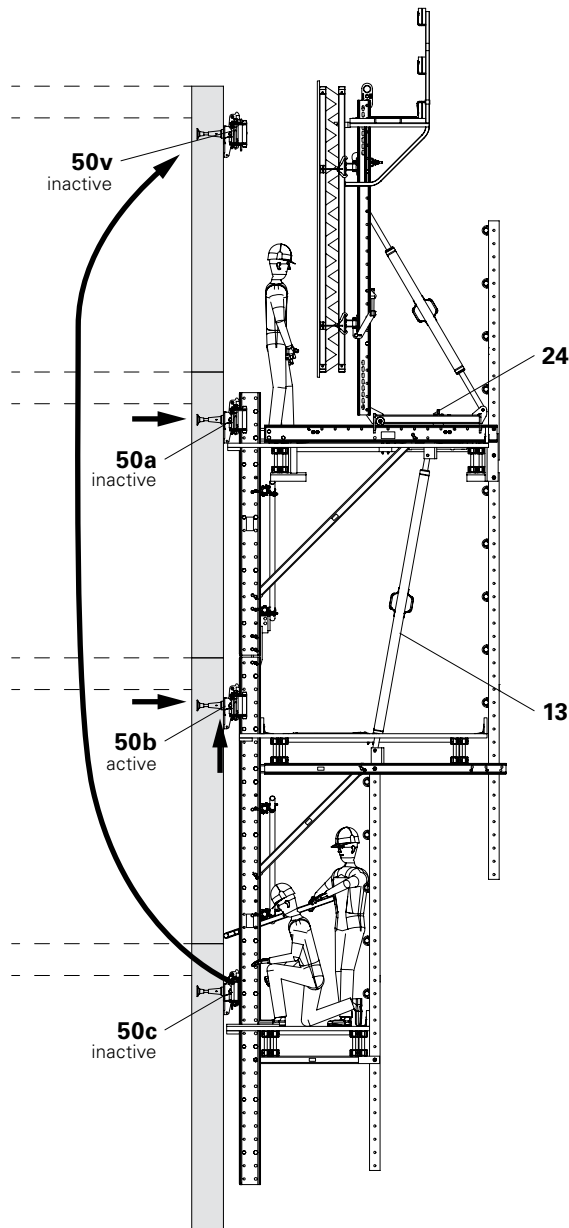

Fig. D6.01

For operating the Climbing Shoe, see Section "D5 Operating the Climbing Shoe" on page 112.

Moving Procedure

Components

- 3** Spacer
- 13** Framework Spindle
- 24** Formwork Carriage
- 25** Strongback
- 50** Climbing Shoe RCS
- 50.1** Climbing Pawl

1. Slowly lift the climbing unit by crane to the next concreting section until the climbing pawls (**50.1**) of the Climbing Shoes (**50a**) audibly engage the planned Spacers (**3**). (Fig. D6.02 + D6.02a)
2. Place the climbing unit on the Climbing Shoes (**50a**) so that the complete weight of the unit is supported.
3. Enter the platform and close the advanced Climbing Shoe (**50v**).
4. If necessary, adjust the framework using the Framework Spindle (**13**).
5. Detach crane lifting gear.
6. Supplement guardrails.



Does the climbing unit rest on both sides of the climbing pawls (**50.1**) of the Climbing Shoes (**50a**)? (Fig. D6.03)
If not:

1. Raise the climbing unit a few centimetres using the crane.
2. Deactivate climbing pawls of the bottom Climbing Shoes (**50b**).
3. Lower climbing unit until the Spacers are fully load-bearing on the climbing pawls of the middle Slab Shoe (**50a**).

After completing the climbing procedure, the advanced Climbing Shoe (**50v**) becomes the top Climbing Shoe (**50a**).

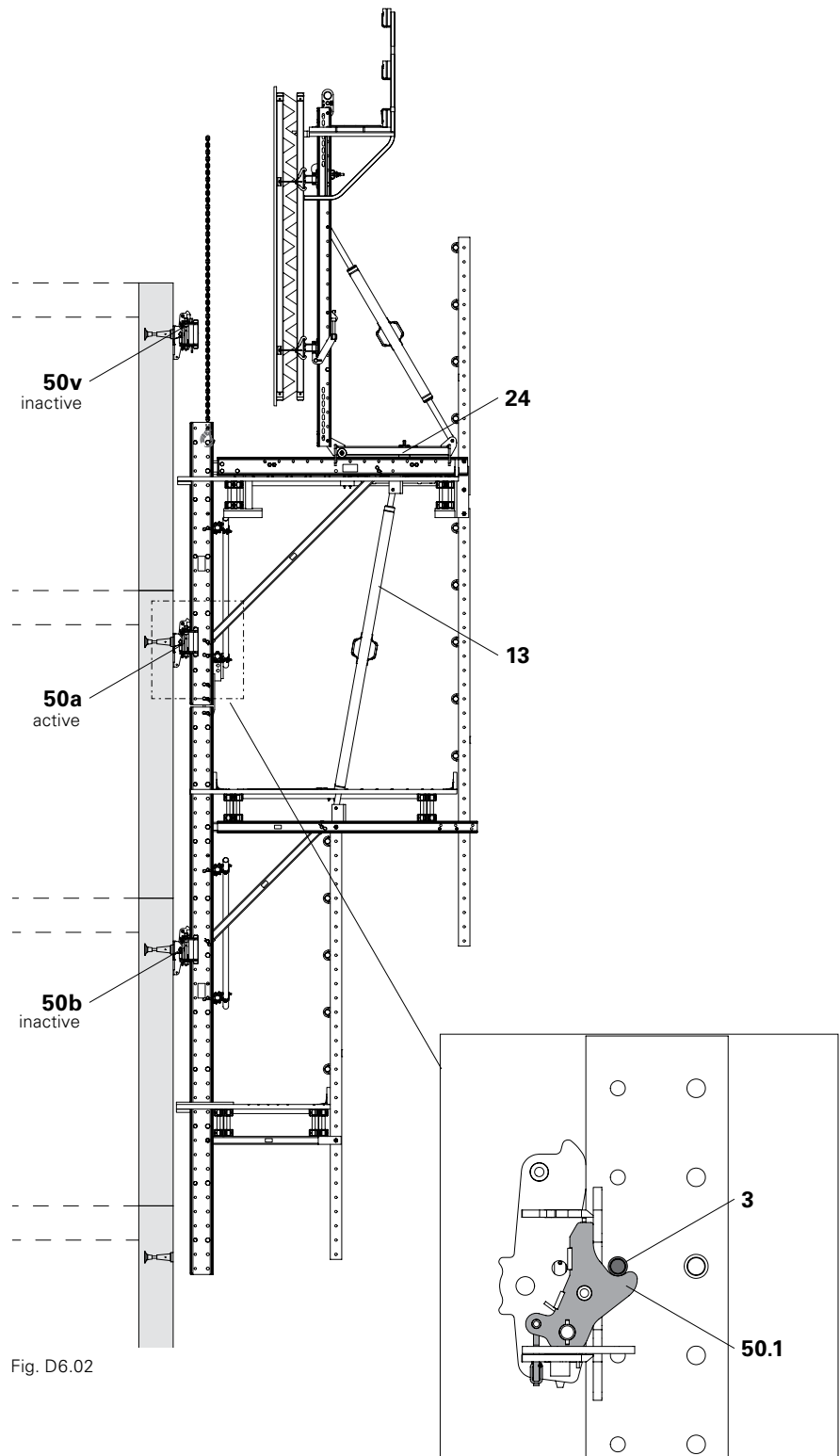

Fig. D6.02

Fig. D6.02a



In particular with enclosed climbing formwork, it is possible that clamping occurs on the Climbing Shoes due to the change in the the centre of gravity. In this case, attach the crane lifting gear to the Strongback (25). Adjust the Carriage (24) so that the Strongback is positioned as far as possible above the centre of gravity of the entire climbing formwork.

⚠ Warning! Unsecured lateral building edges! Use PPE when attaching and removing the crane lifting gear.

If climbed too far

1. Deactivate the climbing pawls of the Climbing Shoes (50v + 50b). Ensure that the pawl locking mechanisms on the Climbing Shoe (50a) are provided with sufficiently long ropes.
2. Leave the climbing unit.
3. Raise the climbing unit by approx. 10 cm using the crane.
4. From a safe position, keep pulling on the pawl locking mechanisms of the middle Climbing Shoe (50a) with the rope.
5. At the same time, lower the climbing unit with the crane until the correct Spacer is approx. 10 cm above, then release the pawl locking mechanisms.
6. Place the climbing unit on the middle Climbing Shoes (50a) so that the complete weight of the unit is supported. Remove rope.



For operating the Climbing Shoe, see Section "D5 Operating the Climbing Shoe" on page 112.

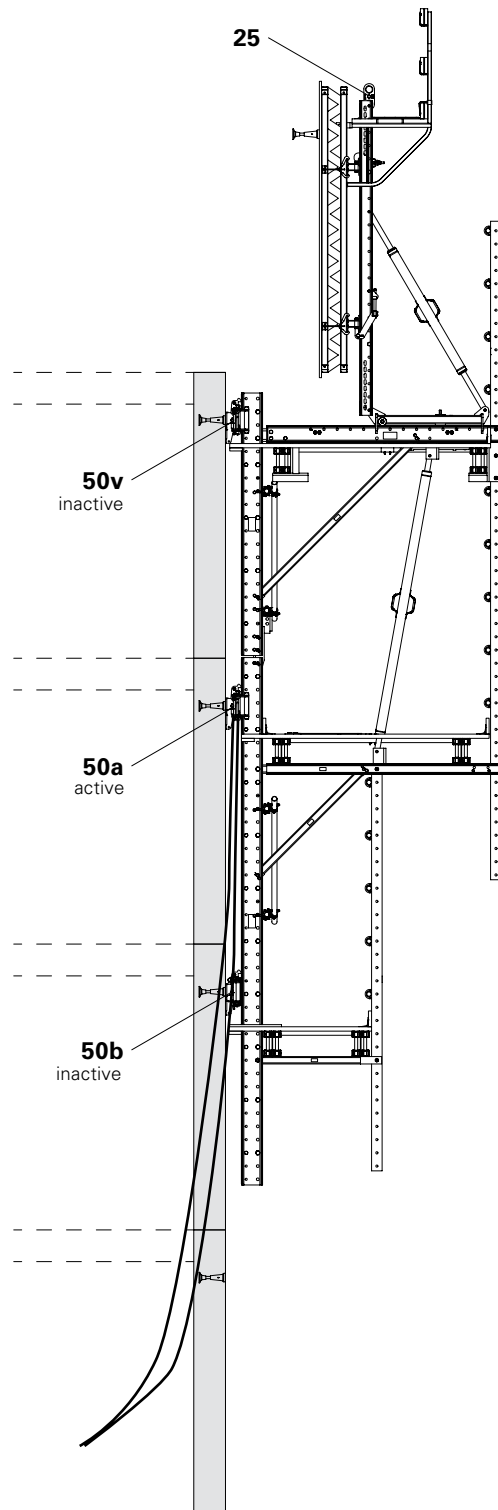

Fig. D6.03

Safety Instructions



Warning

- There is a risk of falling due to unsecured building and platform edges!
- As a result of the moving procedure, slab edges are formed between the platforms!

A fall can result in serious injury or even death.

- ⇒ Mount guardrails before climbing.
- ⇒ Areas of risk are to be cordoned off in advance.
- ⇒ Use personal protective equipment in order to prevent falls.



Warning

Parts of the body can get caught between the Climbing Rail and Climbing Shoe and become trapped! This can cause serious injuries.

- ⇒ Do not take hold of the Climbing Shoes and Climbing Rails while the climbing unit is being moved.



Warning

An operating error or a fault in the hydraulic system, e.g. air, can lead to unwanted movements of the climbing unit!

This can cause serious injuries.

- ⇒ Only access the climbing unit if manual intervention is required.
- ⇒ Put the full weight of the climbing unit on the Climbing Shoes every time before accessing.
- ⇒ Consult the operating personnel before accessing the climbing unit.



- The load-carrying capacity of the structural elements that carry the load-bearing Climbing Shoes must be ensured.
- Do not transport persons, building materials or tools when moving with the crane. These could fall off, leading to serious injury or even death.
- Materials or other components must not protrude beyond the edge of the building. These could hinder the climbing procedure, or fall off.
- Ensure that no parts of the intermediate platform project into the area of the hoses.
- If manual intervention is necessary during the climbing procedure, the platform to be climbed may only be accessed if it completely rests on the Climbing Shoes. Consult the operating personnel.
- In the event of a malfunction, the climbing unit is to be set down in the next possible position and an authorised person is to be informed immediately!
- Install the Hydraulic Hoses so that
 - no loops or knots are created,
 - no loops form beyond the edge of the platform,
 - they do not get tangled with the climbing platforms.
- Up to 2 units can be climbed at the same time.
- Monitor the climbing procedure from a safe position.



For fault-free functioning of the climbing unit, the following points are critical:

- Exact alignment of the anchoring on all 3 axes.
 - Measure the anchoring precisely (perpendicular, chalk line) and mount securely in position.
- The lowest possible weight of the climbing unit.
 - Remove all ballast from the platforms.
 - Do not make climbing units unnecessarily difficult.
- Maintenance status of the Climbing Shoes and Climbing Rails.
 - Regularly clean the Climbing Rails and lubricate the sliding area of the Climbing Shoes. Ensure that the building and platform decking remain free of any lubricant.
- Optimum condition of the entire hydraulic system.
 - Use hydraulic fluid (viscosity) adapted to suit the ambient conditions.
 - Use short hydraulic lines as much as possible.

Hydraulic Diagram

See Fig. D7.01.

The arrangement of the plug connectors and bushings of the quick couplers is clearly shown.

Remedial Measures for Malfunctions

- Uneven cylinder extension and retraction
- Cylinder sinks
- Hydraulic oil leaks
- Cylinder does not extend

See “Assembly Instructions for the RCS Climbing Device and Hydraulics”.

Operating the Hydraulic System

See “Assembly Instructions for the RCS Climbing Device and Hydraulics”.

Bleeding the Hydraulic System

See “Assembly Instructions for the RCS Climbing Device and Hydraulics”.

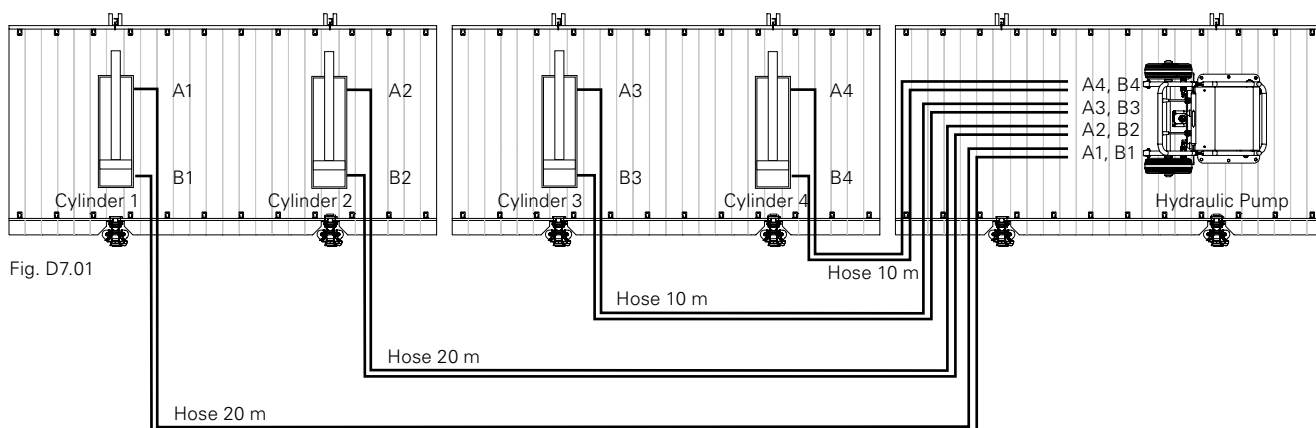

Fig. D7.01

Commencing Climbing Hydraulics Operations

See "Assembly Instructions for the RCS Climbing Device and Hydraulics".

Preparations

The load rests on the middle Climbing Shoe (**50b**).

The self-climbing procedure takes place from the middle Climbing Shoe.

Climbing is controlled from the intermediate platform of the adjacent climbing unit. (Fig. D7.02)

Carry out preparatory work as described in Section "Preparations" on page 117, carry out Points 1 – 8.

In addition:

1. Prepare the climbing hydraulics. See "Assembly Instructions for the RCS Climbing Device and Hydraulics".
2. Ensure the Hydraulic Pump is available.
3. Pull through the hydraulic hoses between the wall and the climbing rails ensuring there are no loops and suspend them on the Wall Shoes with suitable means, e.g. rope or Tension Belt (**144**). (Fig. D7.02)
4. Prepare Climbing Device RCS 50.

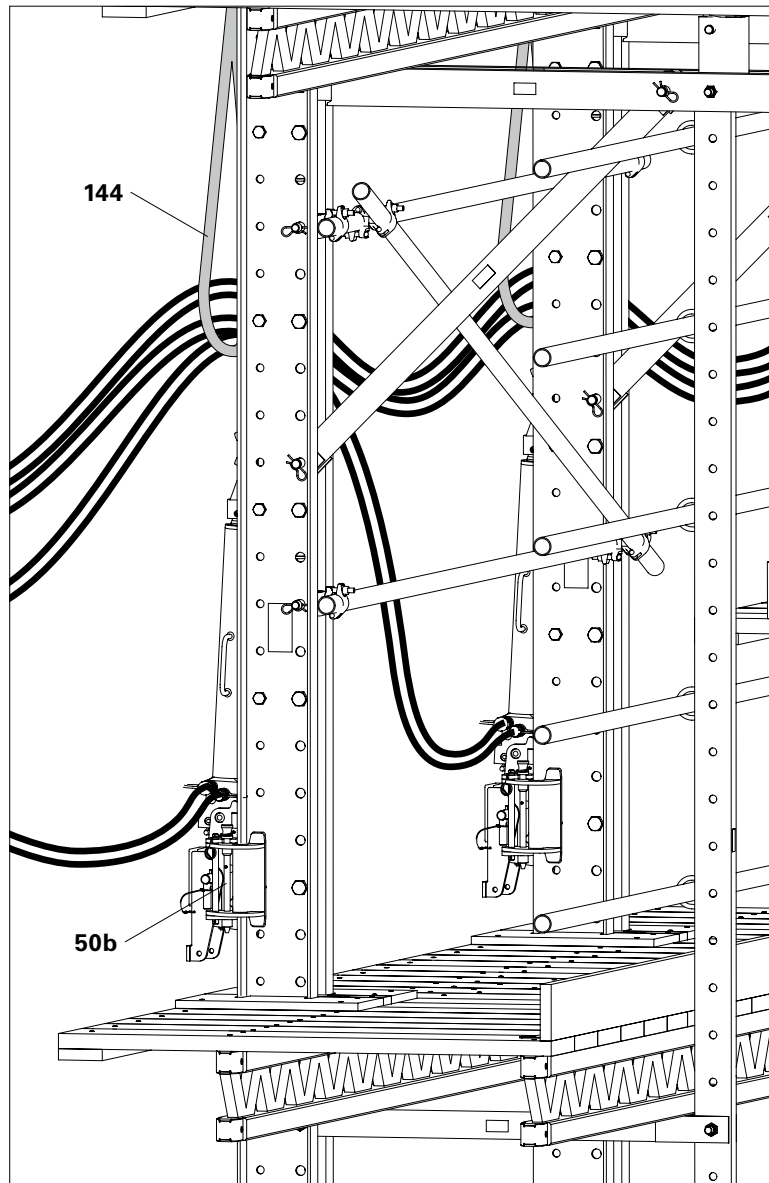

Fig. D7.02

Moving Procedure

For a detailed explanation of the individual steps, see the following section.

Components

- 50** Climbing Shoe RCS
- 60** Climbing Device RCS 50

1. Insert Climbing Device (**60**) and engage with the bolts of the middle Climbing Shoe (**44b**) and connect.
2. Leave the climbing unit, control the climbing procedure from the adjacent climbing unit.
3. Raise the climbing unit from the middle Climbing Shoe with the Climbing Device (**60**) in 50-cm increments. (Fig. D7.03)
4. After the required height has been reached:
 - Stop the climbing procedure.
 - Activate the climbing pawls on the top Climbing Shoe (**50a**).
 - Position the climbing unit with Spacer on the top Slab Shoes (**50a**).



For operating the Climbing Shoe, see Section "D5 Operating the Climbing Shoe" on page 112.

For operating the Climbing Device, see the Assembly Instructions for the RCS Climbing Device and Hydraulics.

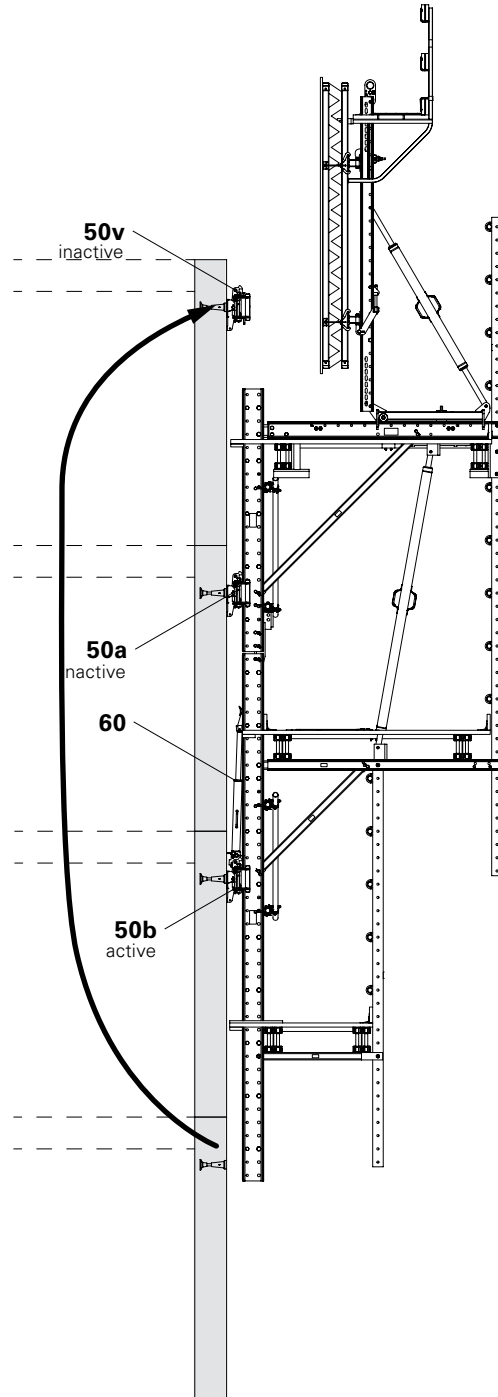

Fig. D7.03

Self-Climbing Procedure

Components: Step 1 – 2

- 3** Spacer M20-82
- 50** Climbing Shoe RCS
- 50.1** Climbing Pawl
- 50.6** Bolt
- 60** Climbing Device RCS 50
- 60.6** Locking Lever

Step 1

1. Position the Climbing Device RCS (**60**) on the bolts (**50.6**) of the middle Climbing Shoe (**50b**) and engage. The Climbing Device is pressed against the Climbing Rail through spring force. Guide the claw into the Climbing Rail. (Fig. D7.04 + D7.05)
3. Attach twin hoses to the Hydraulic Pump and create a short-circuit connection at the other end by coupling them together.
4. Switch on the Hydraulic Pump and flush the hose for approx. 1 minute by operating the hand valve.
5. Disconnect the hose ends from one another and connect to the cylinder.
6. If not already done, activate the climbing pawls of the middle Slab Shoes (**50b**) and deactivate the others.
7. Leave the climbing unit.

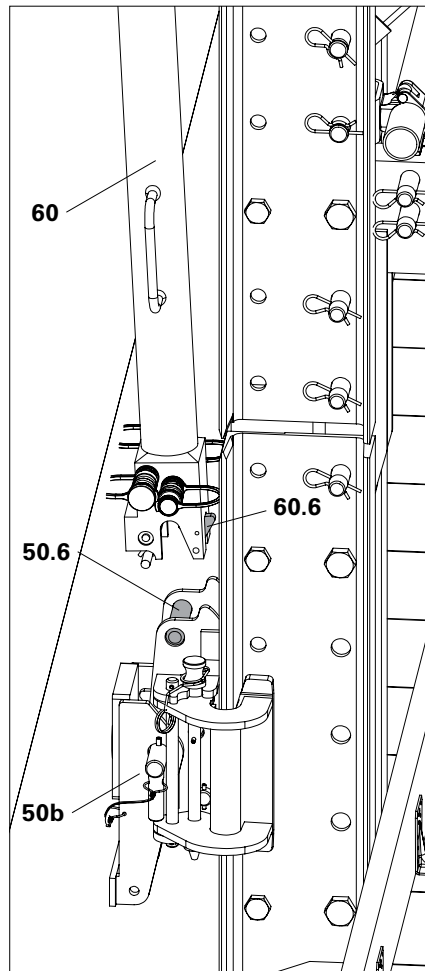

Fig. D7.04

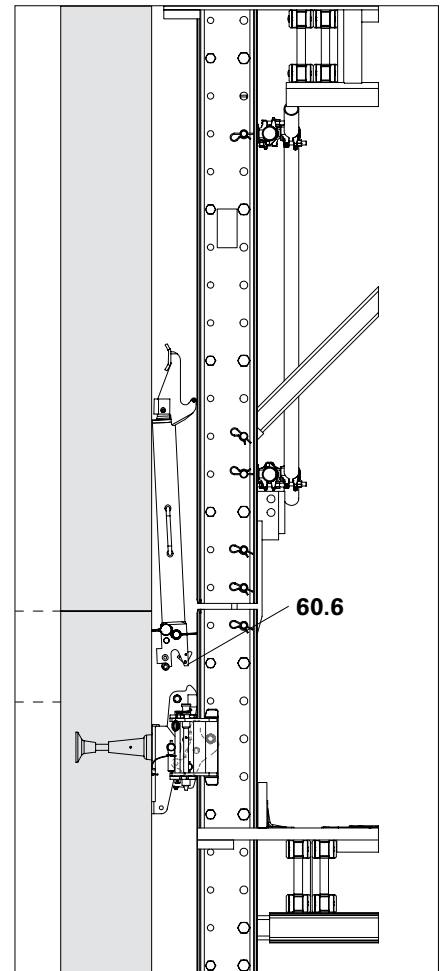

Fig. D7.05



- Is the locking lever (**60.6**) fully engaged on the cylinder base?
- No possibility of the hydraulic hoses becoming entangled?

Step 2

1. Extend the Climbing Device (**60**) up to the first Spacer (**3**).
 2. Load is now carried by the piston with claw (**60.1**).
- (Fig. D7.06)



Are all claws engaged in the Spacers?

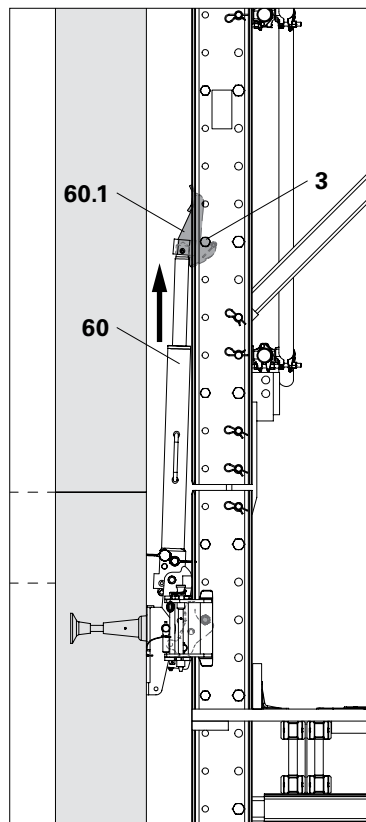

Fig. D7.06

Components: Step 3 – 6

- 3** Spacer M20-82
- 50** Climbing Shoe RCS
- 50.1** Climbing Pawl
- 60** Climbing Device RCS 50
- 60.1** Claw

Step 3

1. Fully extend the Climbing Device (**60**).
2. Climbing pawl (**50.1**) in the Climbing Shoe (**50b**) is pressed inwards by the Spacer when climbing past, then folded out again by means of the spring force (audible click). (Fig. D7.07 + D7.08)

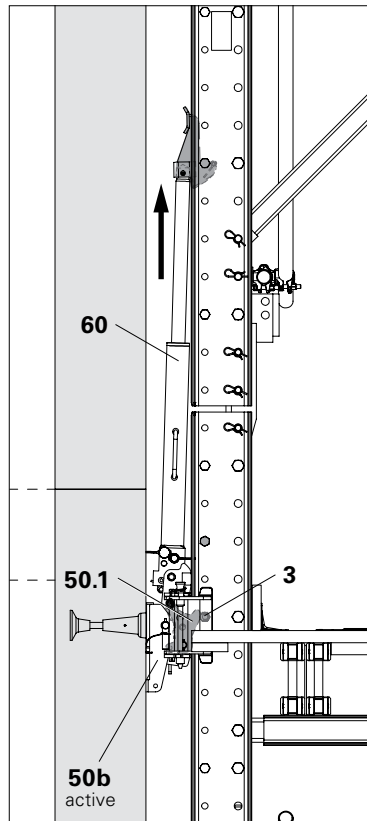

Fig. D7.07

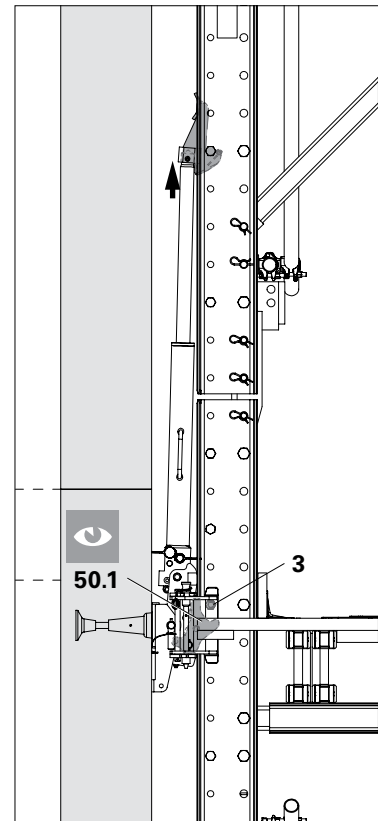

Fig. D7.08



Are the climbing pawls (**50.1**) of all middle Slab Shoes (**50b**) engaged in the Climbing Rail? (Fig. D7.08)

If not:

- Completely extend the Climbing Device. Due to the end position compensation, the following cylinder moves very slowly.
- Climb back, remove cylinder and bleed.

Step 4

1. Retract all Climbing Devices until:
 - the Spacer (**3**) on the climbing pawl (**50.1**) is carried in the middle Slab Shoe (**50b**).
 - claw is relieved by the Spacer (**3a**).
 (Fig. D7.09)

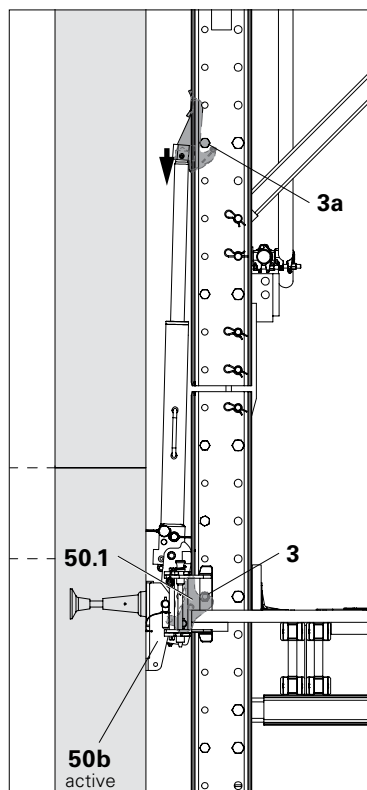

Fig. D7.09

Step 5

1. Continue retracting the Climbing Device (60) until it tilts backwards, and the claw (60.1) slides past the Spacers (3) positioned underneath and engages again below.

(Fig. D7.10)



Are all claws under the Spacers correctly engaged? Otherwise press down by hand. If necessary, further retract the hydraulic cylinder. Check the spring in the base of the Climbing Device. Max. angle of inclination of the Climbing Head in accordance with the rental/inspection criteria.

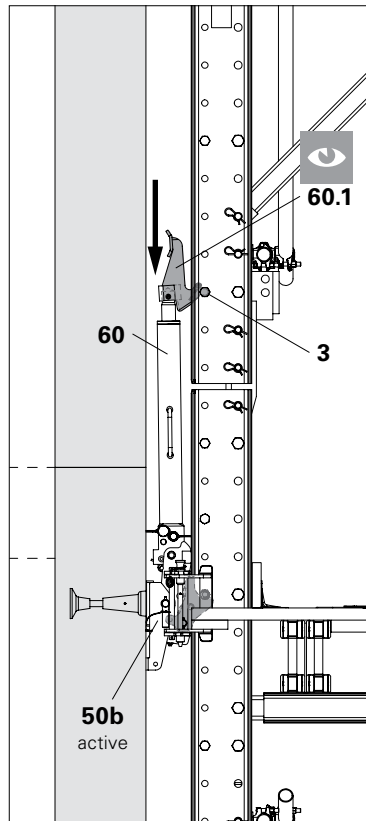

Fig. D7.10

Step 6

1. Extend the Climbing Device (60).
→ Claw (60.1) grips the Spacer (3) and raises the Climbing Rail.
2. By repeating Steps 3 to 6 several times, the climbing unit is gradually climbed upwards in increments of 50 cm.

(Fig. D7.11)



If the hydraulic hoses become taut or entangled, immediately stop the climbing procedure and eliminate the problem!

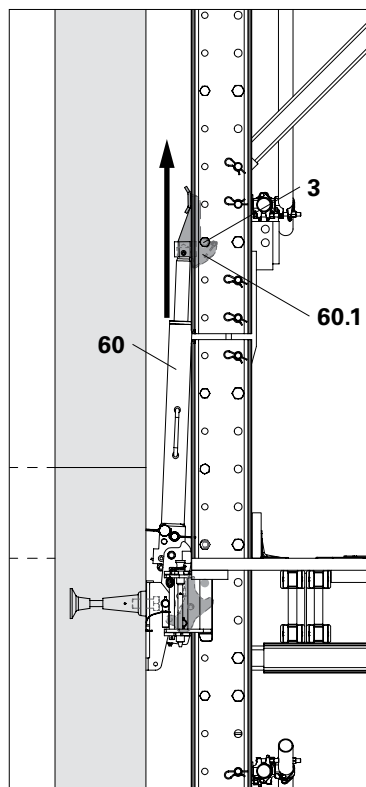

Fig. D7.11

Components: Step 7 – 8

- 3** Spacer M20-82
- 50** Climbing Shoe RCS
- 50.2** Guiding Skid
- 60** Climbing Device RCS 50
- 60.1** Claw

Step 7

When the advanced Climbing Shoe (**50v**) has been reached:

1. Stop the climbing procedure and place the climbing unit on the middle Climbing Shoes (50b, see Fig. D7.10) so that the complete weight of the unit is supported.
 2. If not yet done: open the guiding skids of the advanced Climbing Shoe (**50v**), deactivate the climbing pawl.
 3. If necessary, adjust the Climbing Rail with the Framework Spindle.
 4. Climb one stroke and place the climbing unit on the Climbing Shoes so that the complete weight of the unit is supported.
 5. Close the guiding skids (**50.2**) of the top Climbing Shoe (**50v**). Climbing pawls remain deactivated.
 6. Reset the Framework Spindle.
 7. Continue with the climbing procedure.
- (Fig. D7.12 + D7.13)

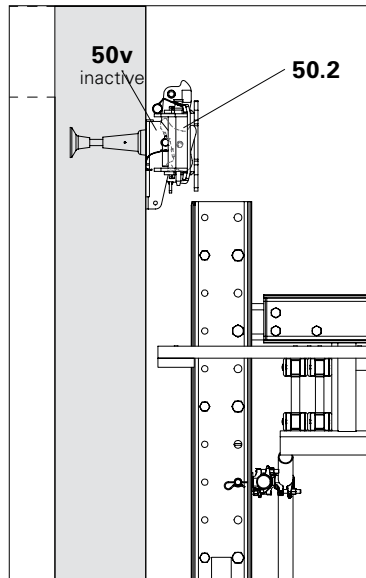

Fig. D7.12

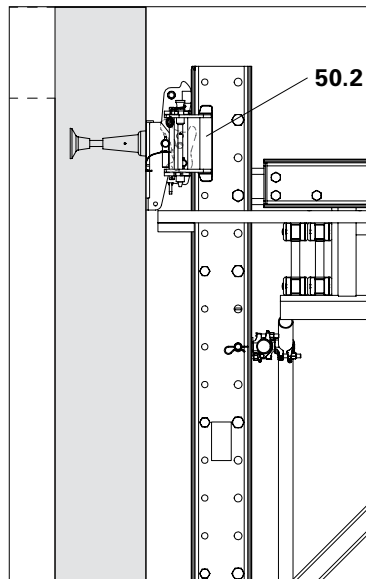

Fig. D7.13

Step 8

1. Before the last lift: activate the climbing pawl on the top Slab Shoe (**50a**).
2. With the last stroke, position the planned Spacer (**3**) above the top Slab Shoe (**50a**).
3. Completely retract the Climbing Device until:
 - the load is carried by the climbing pawl (**50.1**) in the top Slab Shoe (**50a**), (Fig. D7.14b).
 - the claw (**60.1**) is released from the Spacer (**3**).



Is the climbing unit resting on both sides on the climbing pawls (**50.1**) of the planned Climbing Shoes (**50a**)?
If not:

1. Raise climbing unit a few centimetres with the Climbing Device.
2. Deactivate the climbing pawls of the bottom Climbing Shoe (**50b**).
3. Lower climbing unit until the Spacers are fully load-bearing on the climbing pawls of the top Slab Shoe (**50a**).

After completing the climbing procedure, the advanced Climbing Shoe (**50v**) becomes the top Climbing Shoe (**50a**).

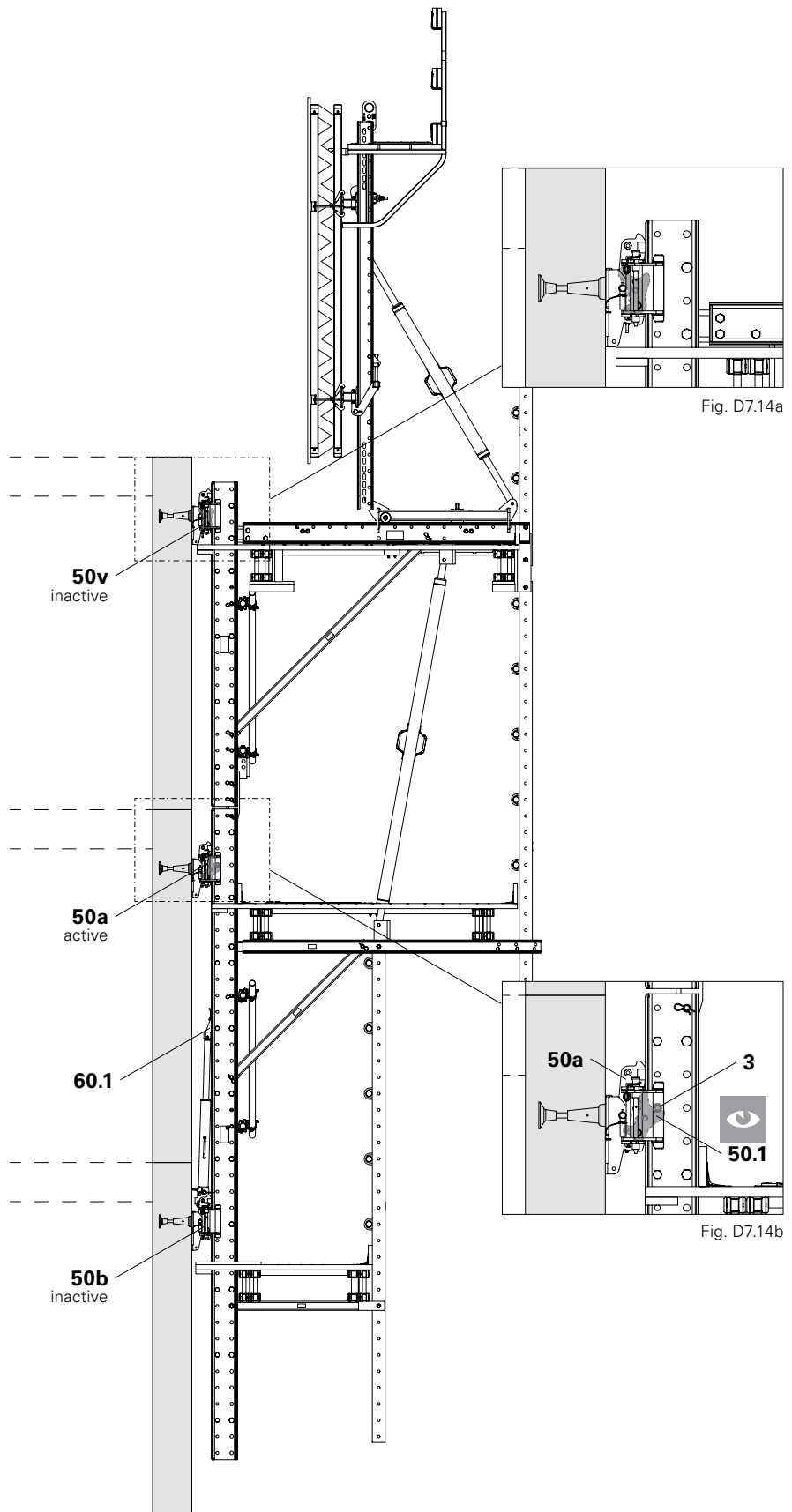

Fig. D7.14

Fig. D7.14a

Fig. D7.14b

Components: Step 9

60 Climbing Device RCS 50

60.6 Locking Lever

Step 9

1. Detach hydraulic hoses from the Climbing Device via the quick couplers.
2. Tilt the Climbing Device backwards, operate the locking lever (**60.6**) on the cylinder base and lift out the Climbing Device. (Fig. D7.15 + D7.15a)
3. Transport the Hydraulic Pump, Climbing Device and hydraulic hoses to the next climbing unit.



In order to prevent the locking lever immediately engaging again after releasing, press the Climbing Device slightly to the side.



When the hydraulic cylinders are not being used, always completely retract the pistons.

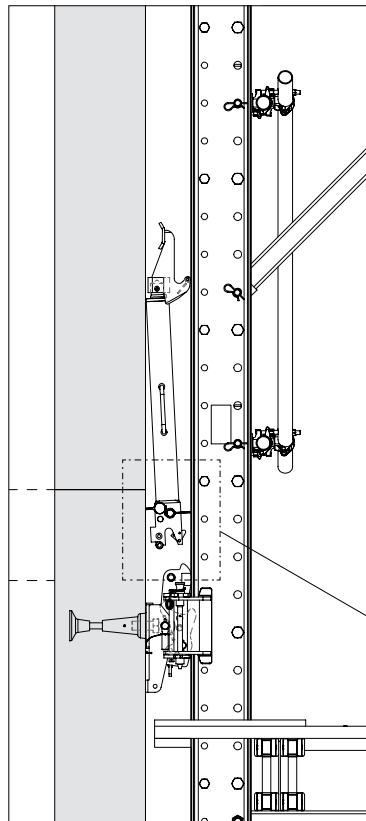

Fig. D7.15

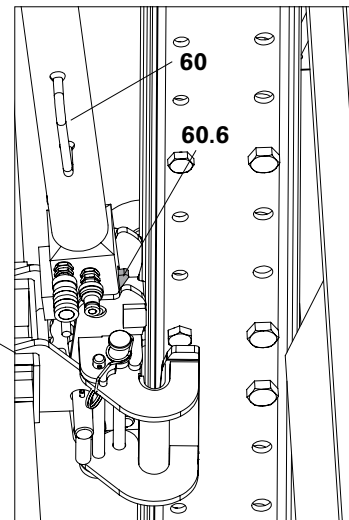

Fig. D7.15a

Finishing tasks

1. Supplement guardrails or re-install.
2. Re-install covering and connections between the platforms of the climbing units.
3. Dismantle trailing Slab Shoe, see Section "Dismantling the suspension" on Page 109.
4. Remove anchoring that is no longer needed, see Section "Dismantling the Climbing Cones" on page 111.

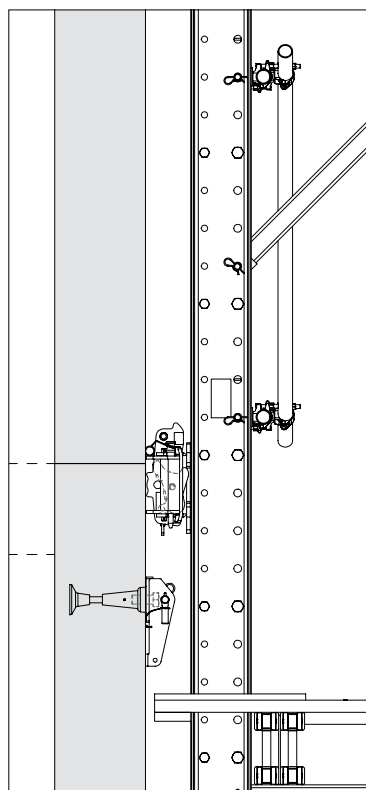

Fig. D7.16

Self-Climbing Procedure of the Last Unit

The Hydraulic Pump is positioned on the intermediate platform of the climbing unit to be climbed.

- Climb one unit at a time so that the hydraulic hoses do not get tangled up.
- Monitor the hydraulic hoses during the climbing procedure.

(Fig. D7.17)



- If the hydraulic hoses become taut or entangled, immediately stop the climbing procedure and eliminate the problem!
- After climbing the last unit, transport the Climbing Devices up to the next storey.

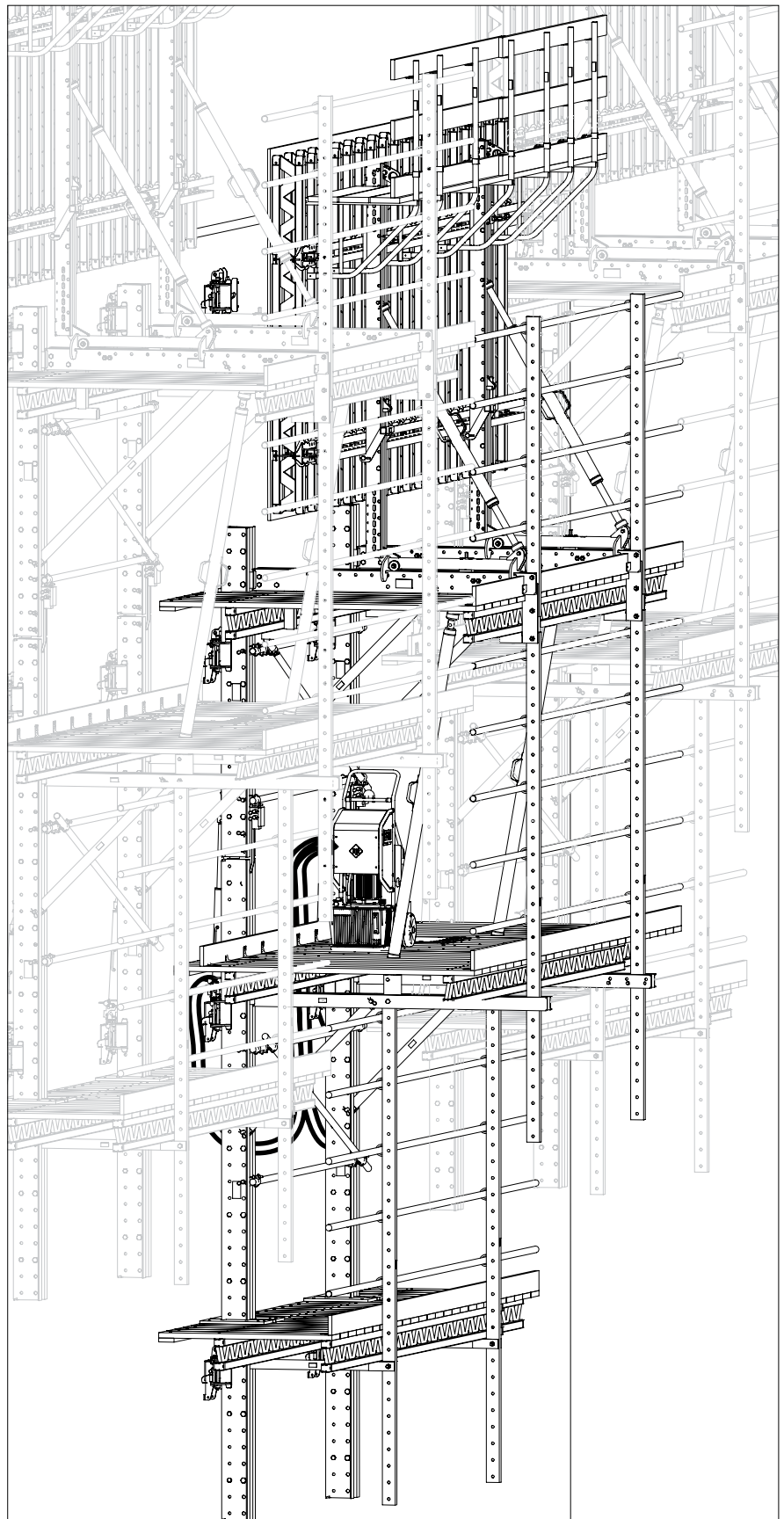

Fig. D7.17

General



Warning

- Risk of falling from unsecured building edges!
A fall can result in serious injury or even death.
⇒ Install guardrails.
⇒ Use personal protective equipment to prevent falling from a height (PPE).
- During assembly on the construction site, components may fall to the ground and hit people below!
This could lead to serious injuries or even death.
⇒ Remove or secure all loose components.
⇒ Cordon off areas of risk under the working areas.

Dismantling the Formwork

Components

- 24** Carriage RCS
- 25** Steel Waler Universal SRU L = 2.72
- 28** Heavy-Duty Spindle SLS 200/300

Dismantling

1. Carry out striking procedure and then retract the Carriage (**24**).
2. Attach the crane lifting gear to the top of the Strongback (**25**) and tension with the crane.
3. Unbolt the Formwork Spindle (**28**) and Strongback (**25**) on the Carriage.
4. Lift out the formwork, place on a suitable assembly place and then dismantle.

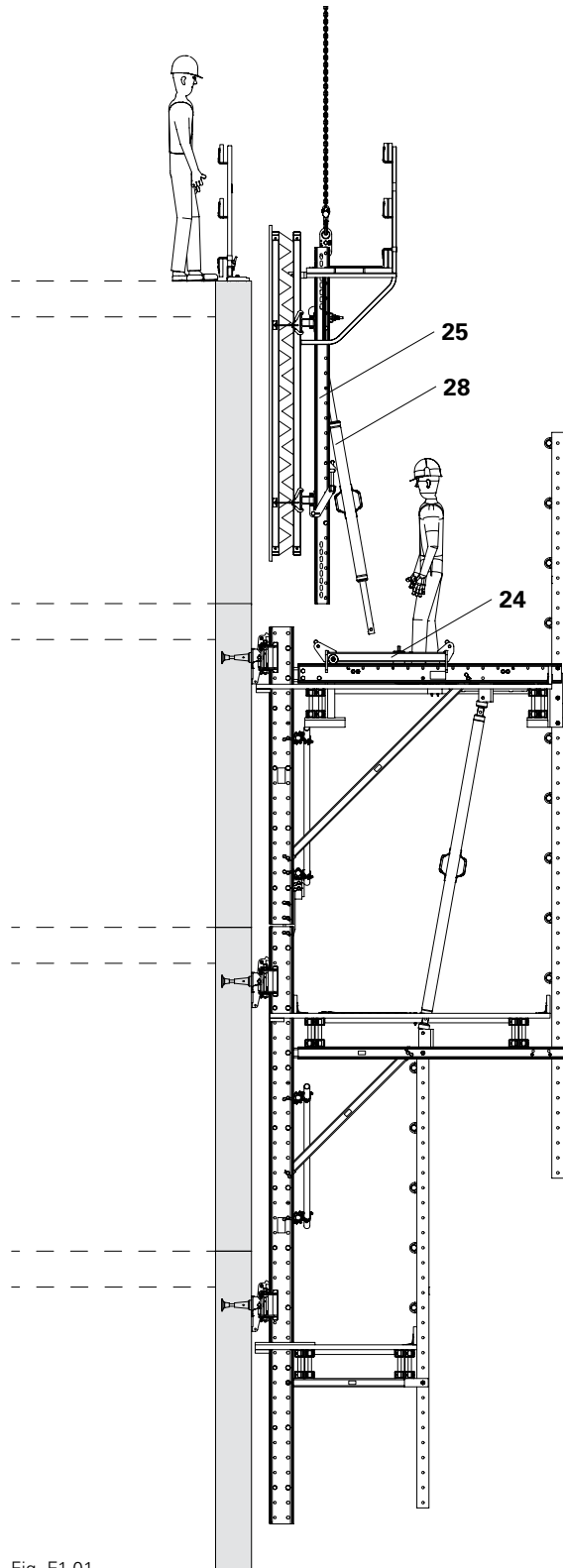

Fig. E1.01

Lifting out the Climbing Unit Separately

Attaching the bracket unit

Requirements

The vertical load rests on the middle Climbing Shoe (**50b**).

Components

- 24** Carriage RCS
- 79** Guardrail Post U100, 225 RCS
- 50** Climbing Shoe RCS

Dismantling

1. Dismantle the side protection (**79**) on the working platform or brace. See Section "C4 Assembly of the Finishing Platform Unit" on page 80. (Fig. E1.02)
2. Move the Carriage (**24**) over the centre of gravity of the climbing unit.
3. Attach climbing unit to the Carriage using 4x fitting pins $\varnothing 21 \times 120$; tension crane lifting gear.
4. Leave the climbing unit.



In the case of low crane heights, it may be necessary to remove the top Climbing Shoe. To do so, adjust the lattice framework, thereby relieving the top Climbing Shoe (**50a**), and then dismantle.

The middle and lower Climbing Shoes carry the climbing formwork.

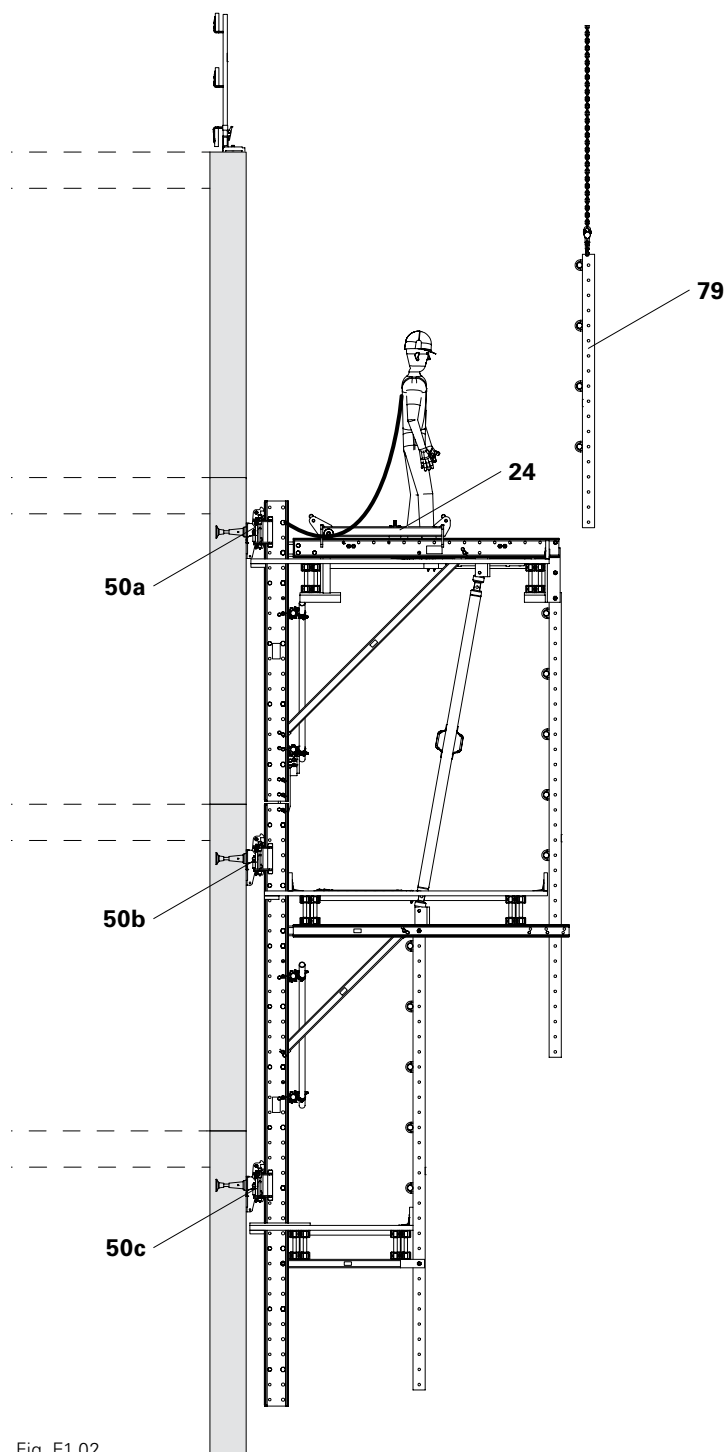

Fig. E1.02

Lifting out the bracket unit

- With PPE from the intermediate platform:
1. On the Climbing Rail Hinge (8), remove bolts $\text{Ø } 25 \times 180$ and cotter pins 4/1 from the finishing platform unit (2).
 2. On the Framework Spindle (13), remove fitting pins $\text{Ø } 21 \times 120$ and cotter pins from the connection of the Intermediate Platform Beam (31.1).
 3. On the Guardrail Post (81) on the connection of the Intermediate Platform Beam (31.2), remove the external fitting pins $\text{Ø } 21 \times 120$ and cotter pins.
 4. Pull the bracket unit out of the Climbing Shoes with the crane.
 5. Lift out the bracket unit, place on a suitable assembly place and then dismantle.

Lifting out the finishing platform unit

- With PPE from the intermediate platform:
1. Attach the finishing platform unit to the Spacer (4) of the Climbing Rail (2) as well as the fitting pins and cotter pins (31.2) on the Intermediate Platform Beam. If necessary, use shortened lifting chains.
 2. Leave the intermediate platform and lift the finishing platform unit upwards out of the Climbing Shoes.
 3. Lift out the finishing platform unit, place on a suitable assembly place and then dismantle.
 4. Remove remaining Climbing Shoe, Wall Shoe and anchoring, ensuring that personnel are always in a safe working position.

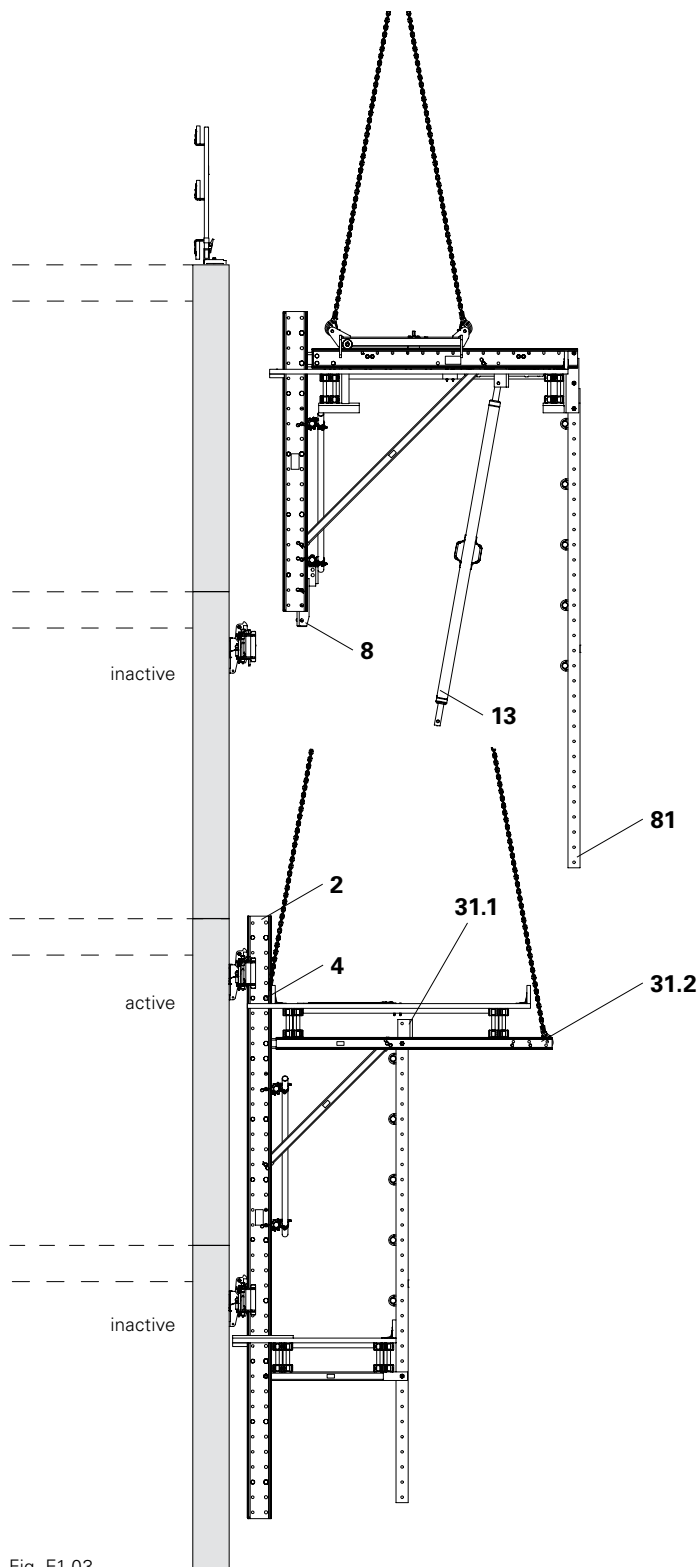

Fig. E1.03

Lifting out the Complete Climbing Unit

Requirements

The vertical load rests on the middle Climbing Shoe (**50b**).

Components

47.5 Climbing Cone-2 M30/DW 20

50 Climbing Shoe RCS

51 Wall Shoe RCS

Dismantling

1. Remove the bottom Climbing Shoe (**50c**), Wall Shoe (**51c**) and Climbing Cone (**47.5**).
2. Dismantle the side protection on the working platform or brace. See Section "C4 Assembly of the Finishing Platform Unit" on page 80.
3. Move the Carriage (**24**) over the centre of gravity of the climbing unit.
4. Attach climbing unit to the Carriage using fitting pins 21 x 120 and cotter pins 4/1.
5. Leave the climbing unit.
6. Pull the climbing unit out of the climbing shoes with the crane.
7. Lift out the climbing unit, place on a suitable assembly place and then dismantle.
8. Remove the remaining Climbing Shoes (**50b + 50a**), Wall Shoe and anchoring, ensuring that personnel are always in a safe working position.



In the case of low crane heights, it may be necessary to remove the top Climbing Shoe (**50a**). To do so, adjust the lattice framework, thereby relieving the top Climbing Shoe, and then dismantle.

The middle and lower Climbing Shoes carry the climbing formwork.

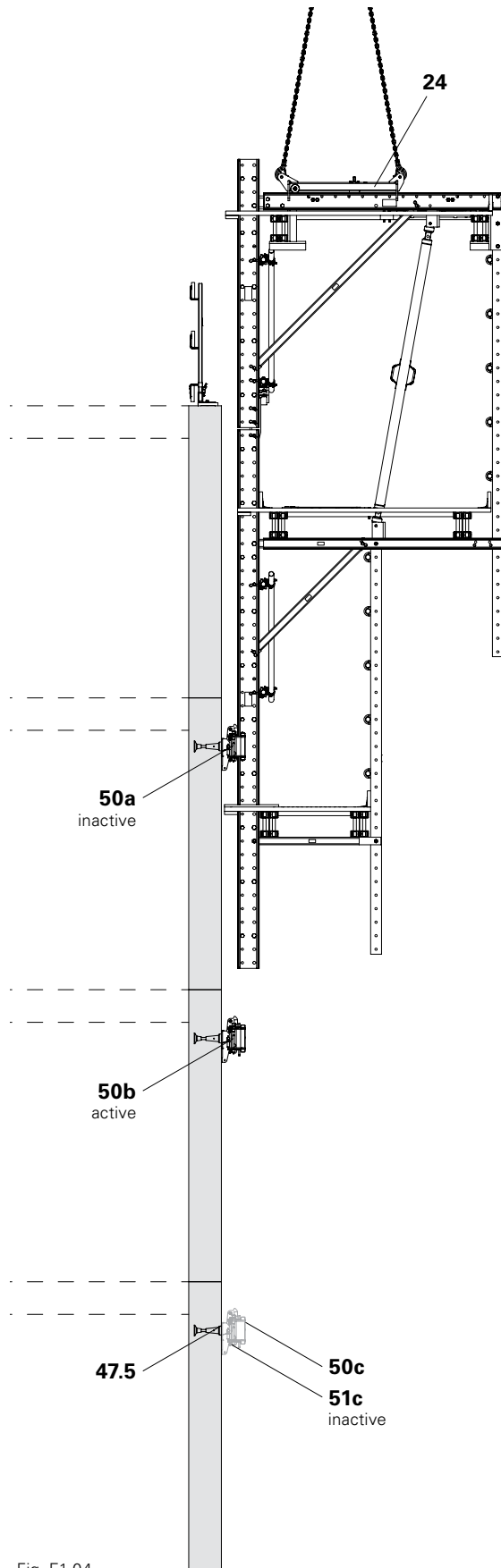

Fig. E1.04

Dismantling the Climbing Unit



Warning

Heavy components could fall to the ground!

Body parts could become trapped, thus causing injuries.

- ⇒ Do not remain in an area of risk.
- ⇒ Do not touch any clamping points.
- ⇒ Attach components to the crane lifting gear for dismantling and tension with the crane.
- ⇒ Secure components to prevent them falling to the ground.

Dismantling

1. Secure the finishing platform (33) to prevent tipping.
2. Dismantle scaffold tubes (88) and Guardrail Posts (79 + 81). (Fig. E2.01)
Alternatively: lift the anti-fall protection as a whole with the crane and place to one side; dismantle separately.
3. Secure Framework Spindle (13) against falling to the ground, remove fitting pins and lift the Framework Spindle to one side. (Fig. E2.02)

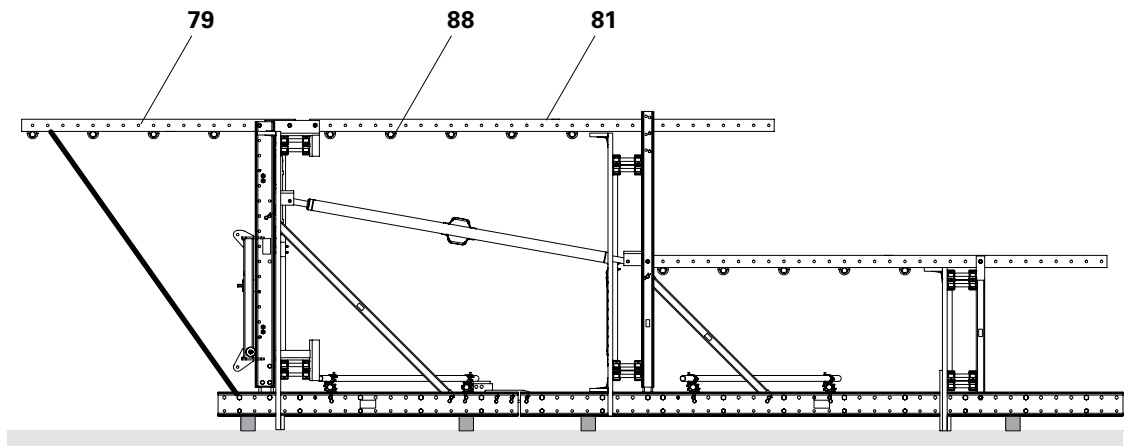

Fig. E2.01

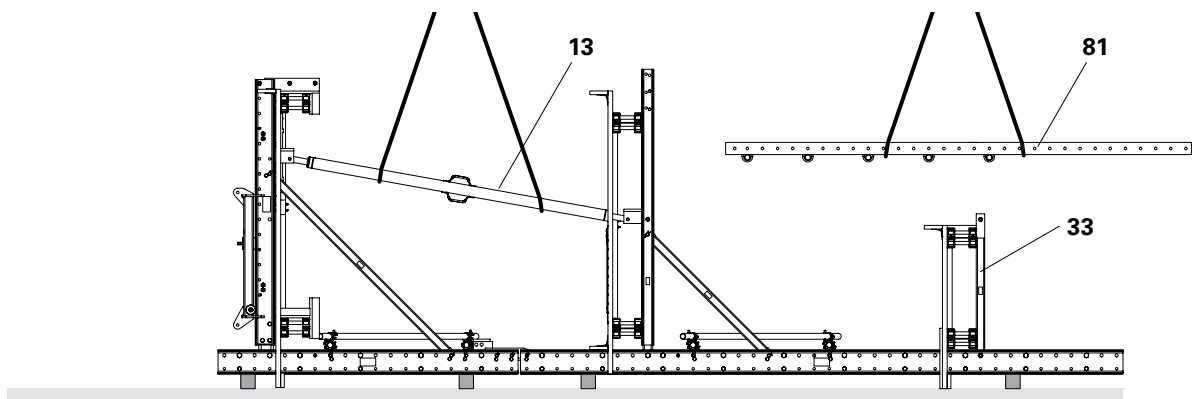

Fig. E2.02

4. Attach the finishing platform (**33**) to the crane lifting gear, tension with the crane.
5. Remove bolt connection between the Finishing Platform Beam and Climbing Rail and then lift the finishing platform to one side with the crane for dismantling.
6. Attach the intermediate platform (**30**) to the crane lifting gear, tension with the crane.
7. Remove the Diagonal Strut (**12**).
8. Remove bolt connection (**31.1**) between the Platform Beam (**31**) and Climbing Rail (**2**) and lift the intermediate platform to one side for dismantling.
9. Dismantle the working platform in the same way. (Fig. E2.03)



For dismantling the individual sub-assemblies, see the respective assembly sections.
Dismantling is carried out in the reverse order.

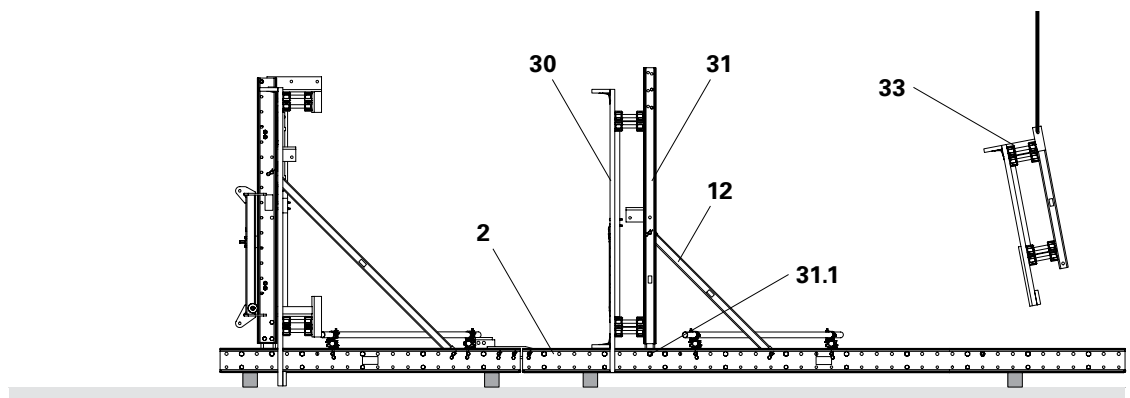
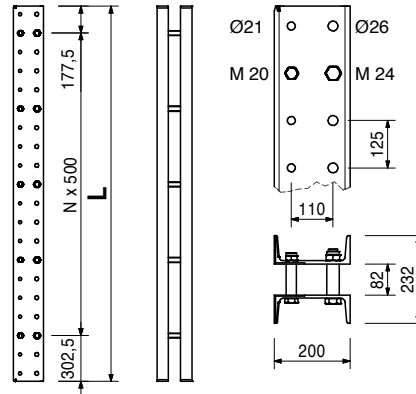

Fig. E2.03

Item no.	Weight kg		L
114166	78.200	Climbing Rails RCS	1480
109469	130.000	Climbing Rail RCS 148	2480
112102	156.000	Climbing Rail RCS 298	2980
109470	182.000	Climbing Rail RCS 348	3480
112141	209.000	Climbing Rail RCS 398	3980
109471	262.000	Climbing Rail RCS 498	4980
109472	393.000	Climbing Rail RCS 748	7480
109610	524.000	Climbing Rail RCS 998	9980

Steel profile for all-purpose use of climbing application or civil constructions. With Spacers M20-82 and M24-82.



110022 0.491

Spacer M20-82
Spacer for Climbing Rails RCS.

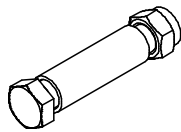

Complete with

- 1 pc. 104477 Bolt ISO 4014 M20 x 120-8.8, galv.
- 1 pc. 130341 Nut ISO 7042 M20-8, galv.

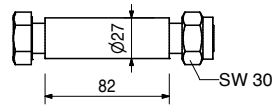

110023 0.910

Spacer M24-82
Spacer for Climbing Rails RCS.

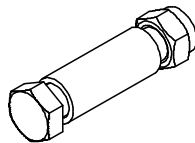

Complete with

- 1 pc. 109612 Bolt ISO 4014 M24 x 130-8.8, galv.
- 1 pc. 130342 Nut ISO 7042 M24-8, galv.

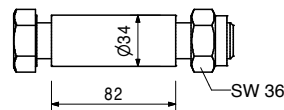

115626 1.880

M24 Kicker Connector RCS
Bolted in holes Ø 26 of the Climbing Rail RCS. Serves for connecting Kicker AV or Bracing DW 15.

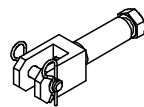

Complete with

- 1 pc. 115916 Pin Ø = 16, L = 70 mm, geomet.
- 2 pc. 018060 Cotter Pin 4/1, galv.
- 1 pc. 109612 Bolt ISO 4014 M24 x 130-8.8, galv.

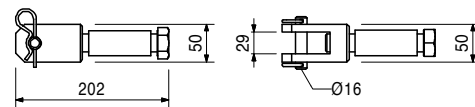

RCS-C Rail Climbing Formwork

Item no.	Weight kg
110569	16.700

Climbing Rail Hinge RCS

For an articulated connection of the Climbing Rails RCS and as pressure point on the RCS Climbing Brackets.

Complete with

3 pc. 710894 Pin \varnothing 25 x 180, geomet.
4 pc. 018060 Cotter Pin 4/1, galv.

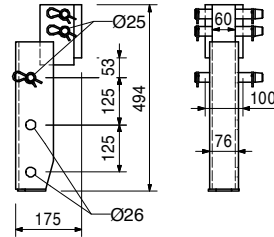
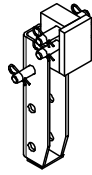

109791	25.900
--------	--------

Climbing Rail Extension RCS 100

As extension of the Climbing Rail RCS for connecting the finishing platform.

Complete with

2 pc. 109612 Bolt ISO 4014 M24 x 130-8.8, galv.
2 pc. 105032 Nut ISO 7040 M24-8, galv.

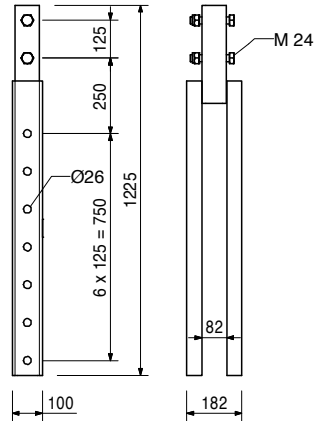
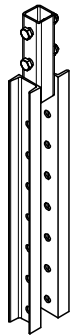

111390	32.800
--------	--------

Climbing Rail Connector RCS 97

For rigidly connecting the Climbing Rails RCS.
With connection for the Heavy-Duty Spindles SLS.

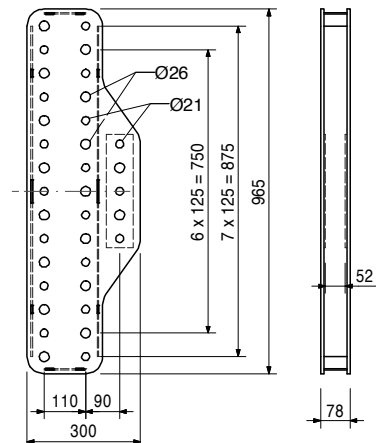
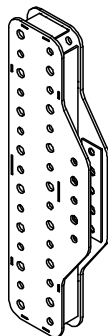

Accessories

104031	0.462	Fitting Pin \varnothing 21 x 120
018060	0.014	Cotter Pin 4/1, galv.
111567	0.729	Fitting Pin \varnothing 26 x 120
022230	0.033	Cotter Pin 5/1, galv.

RCS-C Rail Climbing Formwork

Item no.	Weight kg
113744	21.000

Climbing Rail Connector RCS 73

For rigid connection of Climbing Rails RCS.
Perm. bending moment limited.

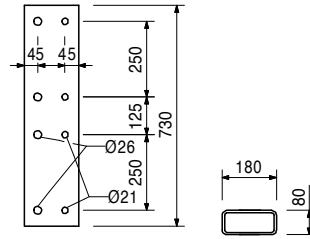
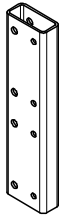

Accessories

104031	0.462	Fitting Pin Ø 21 x 120
018060	0.014	Cotter Pin 4/1, galv.
111567	0.729	Fitting Pin Ø 26 x 120
022230	0.033	Cotter Pin 5/1, galv.

111833	12.700
--------	--------

Climbing Rail Connector RCS 40

For an articulated connection or doubling of the RCS Climbing Rails.

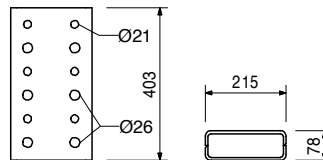
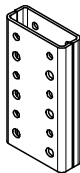

Accessories

104031	0.462	Fitting Pin Ø 21 x 120
018060	0.014	Cotter Pin 4/1, galv.
111567	0.729	Fitting Pin Ø 26 x 120
022230	0.033	Cotter Pin 5/1, galv.

109743	6.370
--------	-------

Climbing Rail Connector RCS 33

For an articulated connection of Climbing Rails RCS.

Complete with

3 pc. 710894 Pin Ø 25 x 180, geomet.
6 pc. 018060 Cotter Pin 4/1, galv.

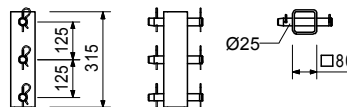

RCS-C Rail Climbing Formwork



Item no.	Weight kg
111283	9.950

Angle Connector RCS/SRU

For right-angled connection of Steel Walers SRU to the Climbing Rails RCS and for attaching guardrail posts to Steel Walers SRU.

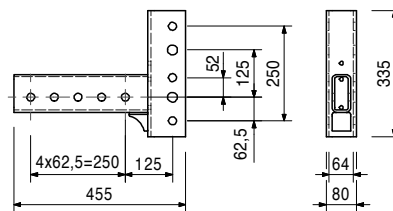
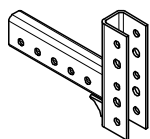

Accessories

104031	0.462	Fitting Pin Ø 21 x 120
018060	0.014	Cotter Pin 4/1, galv.
111567	0.729	Fitting Pin Ø 26 x 120
022230	0.033	Cotter Pin 5/1, galv.

123534	5.910
--------	-------

Brace Connector RCS DW 15/M20

For mounting diagonal bracing with Tie Rod DW 15 and a compression strut to the Climbing Rail RCS.

Complete with

2 pc. 710894 Pin Ø 25 x 180, geomet.
4 pc. 018060 Cotter Pin 4/1, galv.

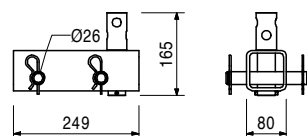
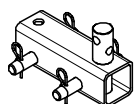

111382	35.200
--------	--------

Climbing Rail Angle Connector RCS

For rigidly connecting the Climbing Rails RCS at right-angles, for frame construction or as bracket. With connection for the Heavy-Duty Spindle SLS and Tie Rod Cylinder Yoke SRU.

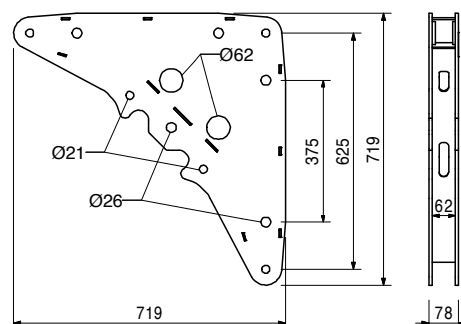
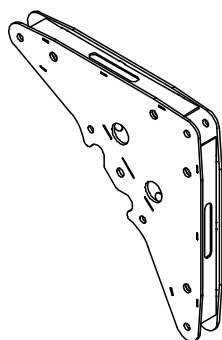

Accessories

104031	0.462	Fitting Pin Ø 21 x 120
018060	0.014	Cotter Pin 4/1, galv.
111567	0.729	Fitting Pin Ø 26 x 120
022230	0.033	Cotter Pin 5/1, galv.
110755	5.140	Tie Yoke SRU

Item no.	Weight kg
104031	0.462

Fitting Pin Ø 21 x 120
For different connections.

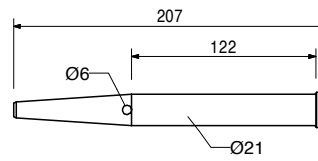
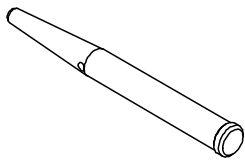

Accessories

018060	0.014
--------	-------

Cotter Pin 4/1, galv.

018060	0.014
--------	-------

Cotter Pin 4/1, galv.



111567	0.729
--------	-------

Fitting Pin Ø 26 x 120
For different connections.

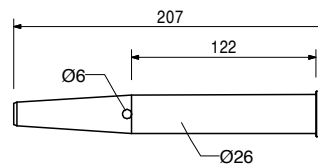
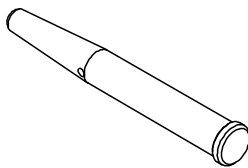

Accessories

022230	0.033
--------	-------

Cotter Pin 5/1, galv.

022230	0.033
--------	-------

Cotter Pin 5/1, galv.



RCS-C Rail Climbing Formwork



Item no.	Weight kg
118094	159.000

Crossbeam Unit RCS 220 VARIO

Platform Beam for RCS climbing formwork.
Assembly unit of Crossbeam RCS 220,
Crossbeam Head RCS/VARIO and Carriage RCS.

Complete with

- 1 pc. 109716 Crossbeam RCS 220
- 1 pc. 110015 Crossbeam Head RCS/VARIO
- 1 pc. 109968 Carriage RCS
- 1 pc. 109612 Bolt ISO 4014 M24 x 130-8.8, galv.
- 1 pc. 105032 Nut ISO 7040 M24-8, galv.
- 1 pc. 104477 Bolt ISO 4014 M20 x 120-8.8, galv.
- 1 pc. 781053 Nut ISO 7040 M20-8, galv.

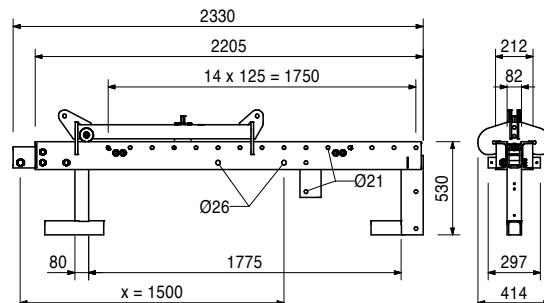
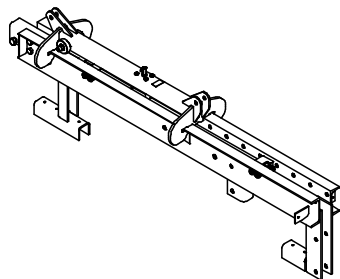

Accessories

110094	0.895
710240	0.050
024390	0.090
024470	0.008
109720	26.600

Carriage Crank Lever SW 19

F.H. Bolt DIN 603 M8 x 100 MU, galv.

F.H. Bolt DIN 603 M8 x 200 MU, galv.

TSS-Torx 6 x 60, galv.

Guardrail Post RCS 226

110285	7.920
--------	-------

Crossbeam Head RCS/TRIO

For connecting the Crossbeam RCS 220 to the
Climbing Rail RCS when using TRIO formwork
(x = 1364).

Complete with

- 1 pc. 109612 Bolt ISO 4014 M24 x 130-8.8, galv.
- 1 pc. 105032 Nut ISO 7042 M24-8, galv.
- 3 pc. 104477 Bolt ISO 4014 M20 x 120-8.8, galv.
- 3 pc. 781053 Nut ISO 7042 M20-8, galv.

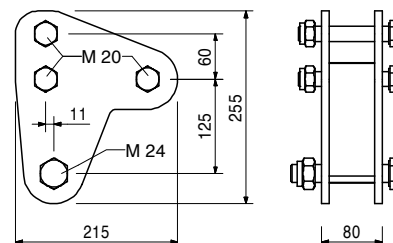
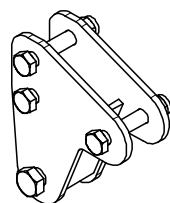

116477	10.600
--------	--------

Platform Beam Support RCS

Support for additional Platform Beams 2 x GT 24
or VT 20 when used with Cross Beam RCS 220.
With connector for Guardrail Post RCS.

Complete with

- 1 pc. 109612 Bolt ISO 4014 M24 x 130-8.8, galv.
- 1 pc. 105032 Nut ISO 7040 M24-8, galv.

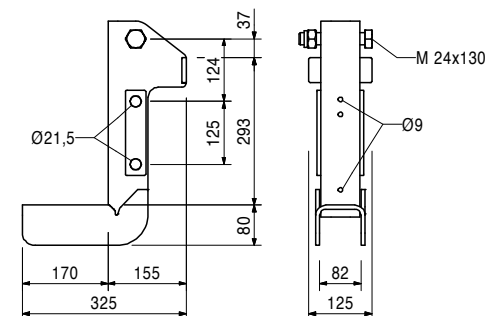
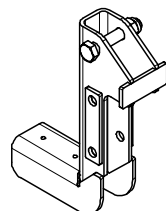

RCS-C Rail Climbing Formwork



Item no.	Weight kg
109717	59.300

Intermediate Platform Beam RCS 241
Platform beam for climbing platform.

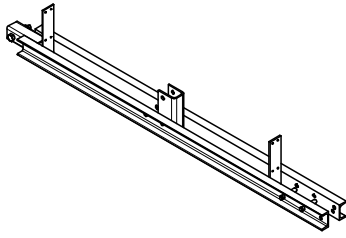

Complete with

- 1 pc. 109612 Bolt ISO 4014 M24 x 130-8.8, galv.
- 1 pc. 105032 Nut ISO 7042 M24-8, galv.
- 2 pc. 104031 Fitting Pin Ø 21 x 120
- 2 pc. 018060 Cotter Pin 4/1, galv.

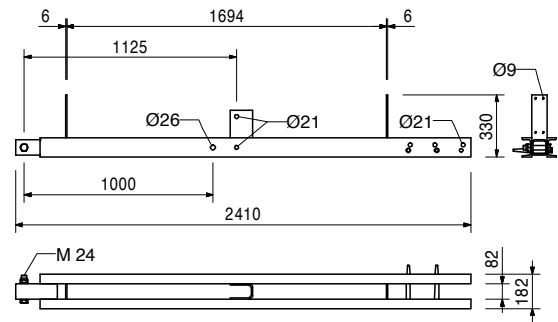

Accessories

710240	0.050
024390	0.090

F.H. Bolt DIN 603 M8 x 100 MU, galv.
F.H. Bolt DIN 603 M8 x 200 MU, galv.

109722	14.200
--------	--------

Finishing Platform Beam RCS 122
Platform beam for finishing platform.

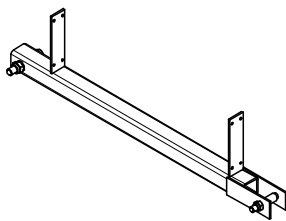

Complete with

- 1 pc. 104477 Bolt ISO 4014 M20 x 120-8.8, galv.
- 1 pc. 781053 Nut ISO 7042 M20-8, galv.
- 1 pc. 109612 Bolt ISO 4014 M24 x 130-8.8, galv.
- 1 pc. 105032 Nut ISO 7042 M24-8, galv.

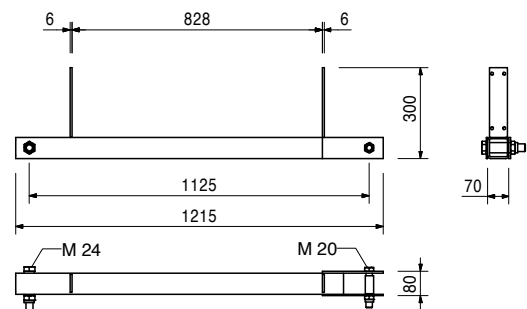

Accessories

710240	0.050
024390	0.090

F.H. Bolt DIN 603 M8 x 100 MU, galv.
F.H. Bolt DIN 603 M8 x 200 MU, galv.

109718	16.600
110012	23.500

Diagonal Struts RCS
Diagonal Strut RCS 142
Diagonal Strut RCS 212
For bracing RCS framework brackets.

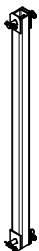

L	X	Y
1512	1000	1000
2217	1500	1500

Complete with

- 2 pc. 109612 Bolt ISO 4014 M24 x 130-8.8, galv.
- 2 pc. 105032 Nut ISO 7040 M24-8, galv.

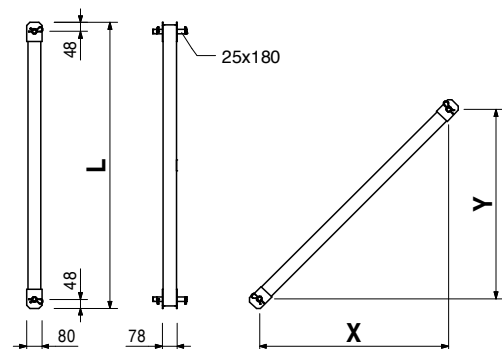

RCS-C Rail Climbing Formwork



Item no.	Weight kg
114301	17.100

Platform Beam RCS/SRU 113

For assembling cantilvered platforms on Steel Walers SRU or Climbing Rails RCS.

Complete with

- 2 pc. 104031 Fitting Pin \varnothing 21 x 120
- 2 pc. 706454 Washer ISO 7089 200 HV, A 20, galv.
- 2 pc. 022230 Cotter Pin 5/1, galv.
- 2 pc. 706458 Bolt ISO 4017 M20 x 40-8.8, galv.
- 2 pc. 781053 Nut ISO 7042 M20-8, galv.

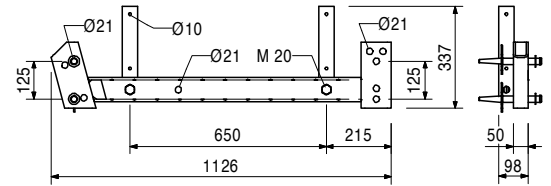
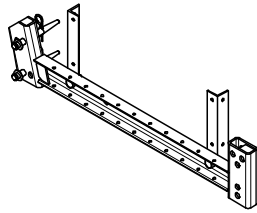

Accessories

114328	16.600
--------	--------

Guardrail Post RCS/SRU 184

114328	16.600
--------	--------

Guardrail Post RCS/SRU 184

For assembly of the guardrail on the Platform Beam RCS/SRU or Angle Connector RCS/SRU.

Complete with

- 2 pc. 114727 Bolt ISO 4017 M20 x 100-8.8, galv.
- 2 pc. 781053 Nut ISO 7040 M20-8, galv.

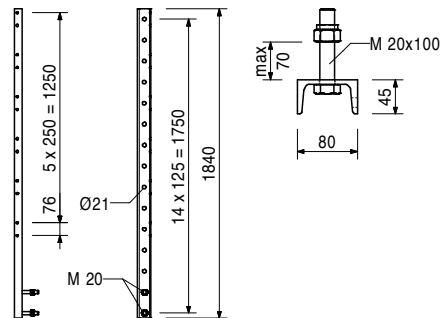

Accessories

110296	0.220
710330	0.017

Clamp A64 DIN 3570 M12, galv. Nut ISO 4032 M12-8, galv.

109720	26.600
--------	--------

Guardrail Post RCS 226

For assembly of the guardrail on the main platform with RCS Formwork Scaffolding or as horizontal strut in the bracing.

Complete with

- 2 pc. 104477 Bolt ISO 4014 M20 x 120-8.8, galv.
- 2 pc. 781053 Nut ISO 7040 M20-8, galv.

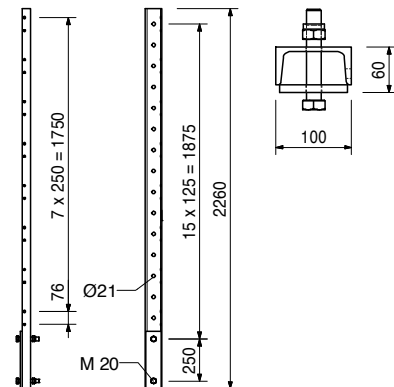

RCS-C Rail Climbing Formwork



Item no.	Weight kg
109721	40.700
109773	67.900

Guardrail Posts RCS Guardrail Post RCS 384 Guardrail Post RCS 509

For assembly of the guardrail on the intermediate and finishing platforms with RCS Formwork Scaffolding or as horizontal strut in the bracing.

Complete with

1 pc. 104477 Bolt ISO 4014 M20 x 120-8.8, galv.
1 pc. 781053 Nut ISO 7040 M20-8, galv.

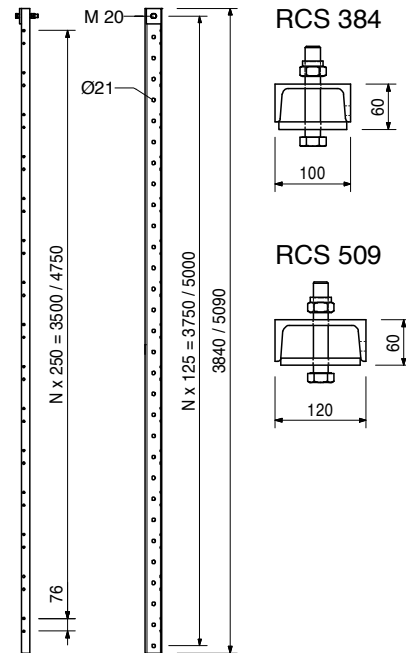

126088	4.390
--------	-------

Guardrail Post Holder Multi

For fixing of an end guardrail post on Girders GT 24, VT 20 or Timbers 80/160.
Fixing of the guardrail posts by means of Hex. Bolts M20 or Clamp A64.

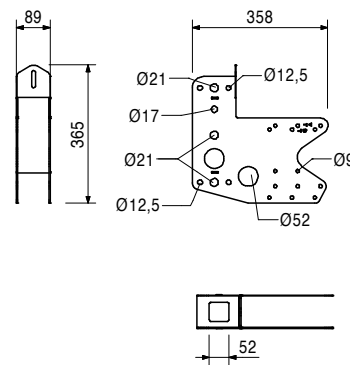
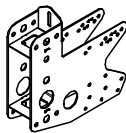

Accessories

710285	0.050
024090	0.005
024470	0.008

Bolt ISO 4014 M8 x 100-8.8, galv.
Nut ISO 4032 M8-8, galv.
TSS-Torx 6 x 60, galv.

RCS-C Rail Climbing Formwork

Item no.	Weight kg		A	min. L	max. L
111035	12.000	Heavy Duty Spindles SLS	344	400	800
101773	15.300	Heavy Duty Spindle SLS 40/80	746	800	1400
101774	18.300	Heavy Duty Spindle SLS 100/180	946	1000	1800
101776	24.900	Heavy Duty Spindle SLS 140/240	1346	1400	2400
101778	32.300	Heavy Duty Spindle SLS 200/300	1944	2000	3000
101779	38.500	Heavy Duty Spindle SLS 260/360	2544	2600	3600
109726	44.800	Heavy Duty Spindle SLS 320/420	3144	3200	4200
109785	51.000	Heavy Duty Spindle SLS 380/480	3744	3800	4800

Used as adjustable spindle for truss beams made of Steel Walers SRU and Climbing Rails RCS.

Note

Permissible load see PERI Design Tables.

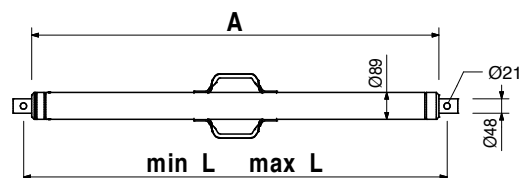
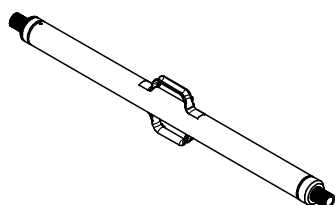

Accessories

104031	0.462	Fitting Pin Ø 21 x 120
018060	0.014	Cotter Pin 4/1, galv.
110477	3.990	Spindle Adapter SLS/RCS
129695	0.028	Reducing Sleeve Ø 26 - 21, galv.

110477	3.990	Spindle Adapter SLS/RCS	Complete with
		For connecting the Heavy-Duty Spindle SLS to the Climbing Rail RCS.	1 pc. 104031 Fitting Pin Ø 21 x 120
			1 pc. 018060 Cotter Pin 4/1, galv.

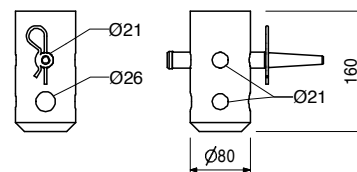
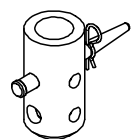

Accessories

104031	0.462	Fitting Pin Ø 21 x 120
018060	0.014	Cotter Pin 4/1, galv.
111567	0.729	Fitting Pin Ø 26 x 120
022230	0.033	Cotter Pin 5/1, galv.

Item no.	Weight kg		L
		Steel Walers Universal SRU U120	
103868	18.100	Steel Waler Universal SRU U120, l = 0.72 m	722
103871	24.200	Steel Waler Universal SRU U120, l = 0.97 m	972
103874	30.900	Steel Waler Universal SRU U120, l = 1.22 m	1222
103877	38.100	Steel Waler Universal SRU U120, l = 1.47 m	1472
103886	44.700	Steel Waler Universal SRU U120, l = 1.72 m	1722
103889	52.000	Steel Waler Universal SRU U120, l = 1.97 m	1972
103898	58.600	Steel Waler Universal SRU U120, l = 2.22 m	2222
103892	65.600	Steel Waler Universal SRU U120, l = 2.47 m	2472
103929	72.000	Steel Waler Universal SRU U120, l = 2.72 m	2722
103903	81.000	Steel Waler Universal SRU U120, l = 2.97 m	2972
103906	92.600	Steel Waler Universal SRU U120, l = 3.47 m	3472
103915	106.000	Steel Waler Universal SRU U120, l = 3.97 m	3972
103918	119.000	Steel Waler Universal SRU U120, l = 4.47 m	4472
103922	135.000	Steel Waler Universal SRU U120, l = 4.97 m	4972
103925	146.000	Steel Waler Universal SRU U120, l = 5.47 m	5472
103928	159.000	Steel Waler Universal SRU U120, l = 5.97 m	5972

Universal Steel Waler Profile U120 used as waling for girder wall formwork and for diverse special applications. With adjustable spacers.

Note
Permissible load: see PERI Design Tables.

Technical Data
U120: $W_y = 121.4 \text{ cm}^3$, $I_y = 728 \text{ cm}^4$.

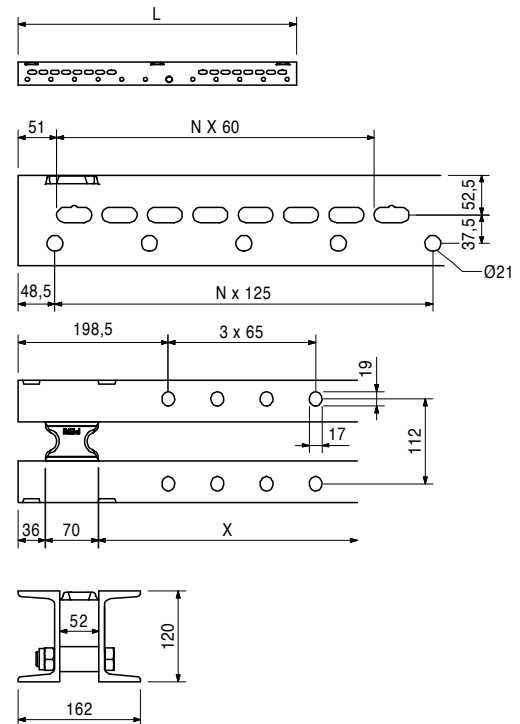
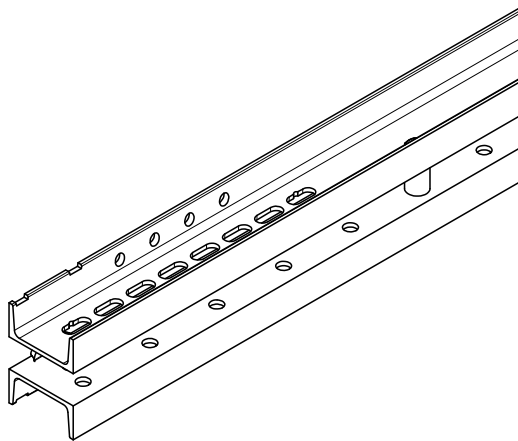

020620 0.561

Spacer for Platform Beam BR
For Platform Beam BR or Steel Walers SRU.

Complete with
1 pc. 710226 Bolt ISO 4014 M20 x 90-8.8, galv.
1 pc. 781053 Nut ISO 7040 M20-8, galv.

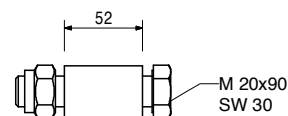
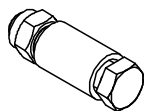

RCS-C Rail Climbing Formwork

Item no.	Weight kg
110059	2.840

Waler Fixation U100 – U120

For fixing VARIO GT 24 Panels to Strongbacks CB, SCS and Steel Waler SRU.

Complete with

1 pc. 110055 Cross Clamp, galv.
1 pc. 118260 Spherical Nut RD 16, galv.

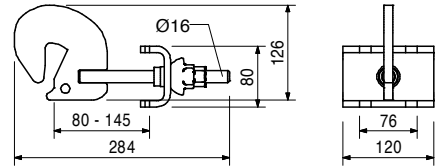
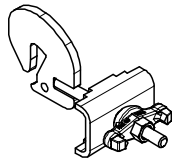

110400	7.150
--------	-------

Adjusting Unit SRU, external

For the external height adjustment of the formwork element at the strongback (Steel Waler SRU).

Complete with

1 pc. 105400 Pin Ø 20 x 140, galv.
1 pc. 018060 Cotter Pin 4/1, galv.
1 pc. 706454 Washer ISO 7089 200 HV, A 20, galv.
1 pc. 110637 Schr. ISO 4017-M20X260 BEARB.
1 pc. 780807 Sleeve ISO8752-08, 0 x 028, galv.

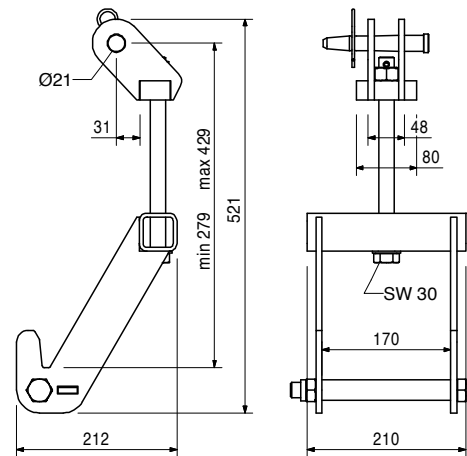
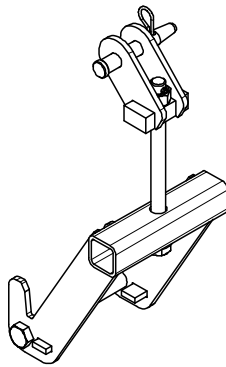

111135	5.620
--------	-------

Adjusting Unit SRU, internal

For internal height adjustment of the formwork on the strongback (Steel Waler SRU) or Climbing Rail RCS.

Complete with

1 pc. 105400 Pin Ø 20 x 140, galv.
1 pc. 018060 Cotter Pin 4/1, galv.

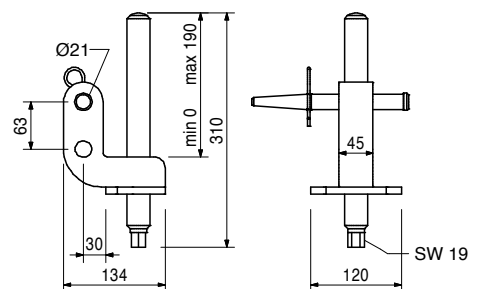
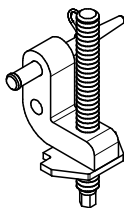

RCS-C Rail Climbing Formwork



Item no.	Weight kg
115325	16.600

Strongback Adapter RCS/SRU

For mounting the Strongback SRU to the Carriage RCS when used with TRIO.

Complete with

2 pc. 105400 Pin \varnothing 20 x 140, galv.
2 pc. 018060 Cotter Pin 4/1, galv.

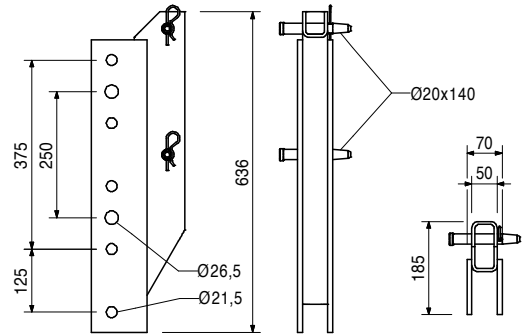
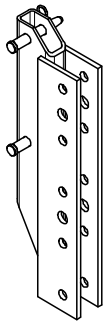

115623	5.040
--------	-------

Connector SRU VARIOKIT

For a rigid connection of Steel Walers SRU.

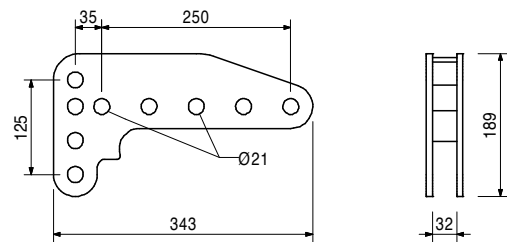
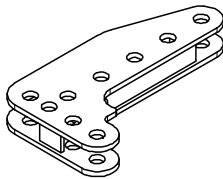

104031	0.462
018060	0.014

Accessories

Fitting Pin \varnothing 21 x 120
Cotter Pin 4/1, galv.

111403	4.840
--------	-------

Mounting Castor Climbing Rail RCS

For mounting and moving formwork elements on horizontally-positioned Climbing Rails RCS.

Technical Data

Permissible load-bearing capacity 1.5 t.

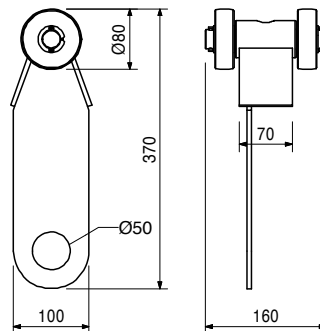
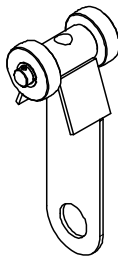

057050	4.450
--------	-------

Suspension Tube Vario 53

For attaching VARIO GT 24 Elements.

Complete with

2 pc. 710593 Bolt ISO 4014 M10 x 80-8.8, galv.
2 pc. 710234 Nut ISO 4032 M10-8, galv.

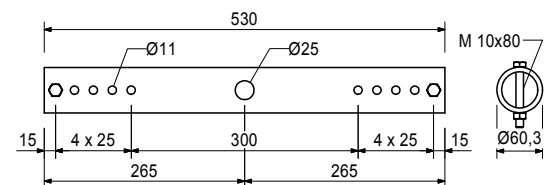
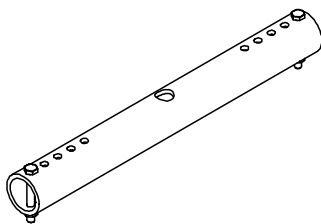

RCS-C Rail Climbing Formwork

Item no.	Weight kg
125823	2.170

Formwork Suspension VARIO GT 24, Ø 60

For connecting the Suspension Tube VARIO 53 to Formwork Girders GT 24.

Note

Permissible load-bearing capacity see PERI Design Information (on request).
At least 2 pieces per fixing point.

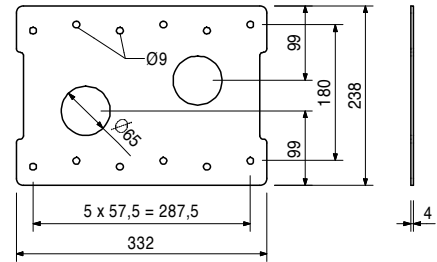
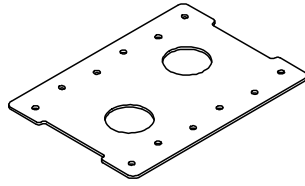

Accessories

024540	0.005
024470	0.008

TSS-Torx 6 x 40, galv.

TSS-Torx 6 x 60, galv.

		Scaffold Tubes Steel Ø 48.1 x 3.2	
026415	3.550	Scaff. Tube Steel Ø 48.3 x 3.2, special length	
026417	0.000	Cutting Cost Scaffold Tube	
026411	3.550	Scaff. Tube Steel Ø 48.3 x 3.2, l = 1.0 m	L
026412	7.100	Scaff. Tube Steel Ø 48.3 x 3.2, l = 2.0 m	1000
125976	8.900	Scaff. Tube Steel Ø 48.3 x 3.2, l = 2.5 m	2000
026413	10.650	Scaff. Tube Steel Ø 48.3 x 3.2, l = 3.0 m	2500
114287	12.500	Scaff. Tube Steel Ø 48.3 x 3.2, l = 3.5 m	3000
026414	14.200	Scaff. Tube Steel Ø 48.3 x 3.2, l = 4.0 m	3500
026419	17.750	Scaff. Tube Steel Ø 48.3 x 3.2, l = 5.0 m	4000
026418	21.600	Scaff. Tube Steel Ø 48.3 x 3.2, l = 6.0 m	5000
			6000

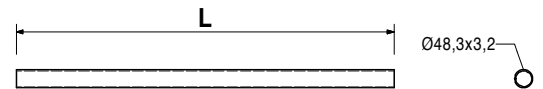
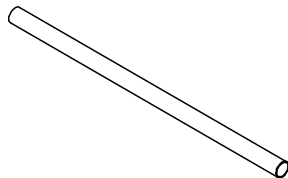

017010	1.400
--------	-------

Swivel Coupling SW 48/48, galv.

For Scaffold Tubes Ø 48 mm.

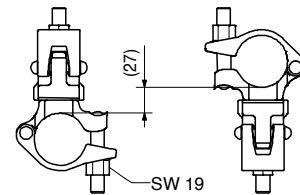
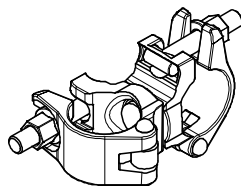

017020	1.120
--------	-------

Standard Coupler RA 48/48, galv.

For Scaffold Tubes Ø 48 mm.

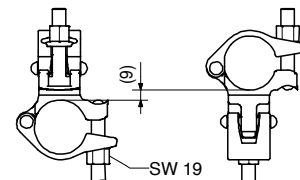
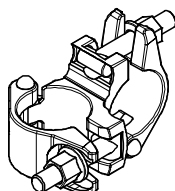

RCS-C Rail Climbing Formwork



Item no.	Weight kg
110084	2.510

Scaffold Tube Adapter Ø 48 RCS

For connecting Scaffold Tubes Ø 48 mm to Climbing Rails RCS.

Complete with

- 1 pc. 017040 Screw-On Coupler AK 48, galv.
- 1 pc. 710894 Pin Ø 25 x 180, geomet.
- 2 pc. 018060 Cotter Pin 4/1, galv.

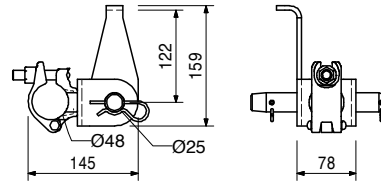
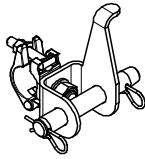

110296	0.220
--------	-------

Clamp A64 DIN 3570 M12, galv.

For assembling Scaffold Tubes Ø 48 or Ø 60.

Note

Wrench size SW 19.

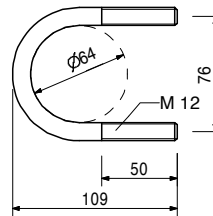
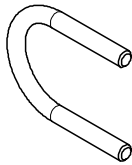

Accessories

710330	0.017
--------	-------

Nut ISO 4032 M12-8, galv.

710330	0.017
--------	-------

Nut ISO 4032 M12-8, galv.

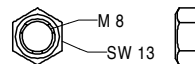

131404	1.080
--------	-------

Screw-On Coupler-2 HT B Ø 48-M20, galv.

For Screwing Scaffold Tubes Ø 48 mm to components up to 9 mm thickness.

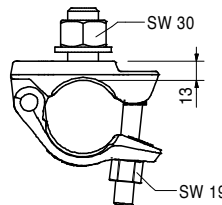
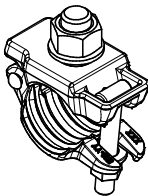

RCS-C Rail Climbing Formwork

Item no.	Weight kg
110289	4.260

L-Angle RCS 120 x 120 x 200
For fixing end handrail posts on the decking.

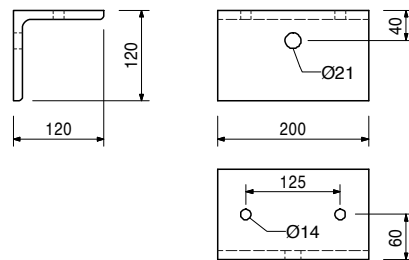
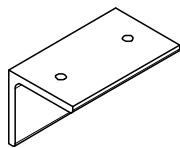

017040	0.850
--------	-------

Accessories
Screw-On Coupler AK 48, galv.

123478	0.255
--------	-------

Toe Board Angle 90°
For diverse timber connections.

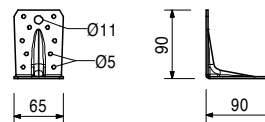

024550	0.005
129711	0.010

Accessories
Spax Screw TX 30 8 x 20, yellow galv.
Spax Screw TX 25, 6 x 20, yellow galv.

125973	12.400
--------	--------

Cover Strip Rubber 0.20 x 10 m
Universal elastic covering for closing gaps between platforms.

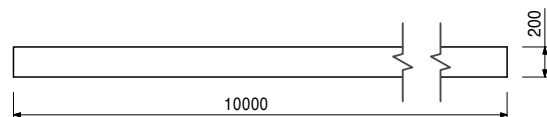
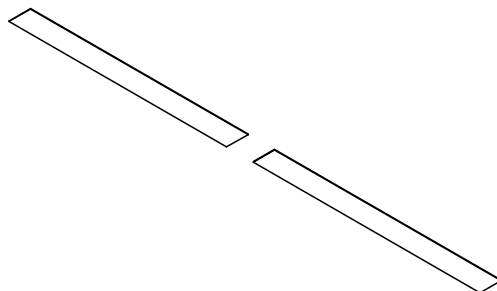

114727	0.321
--------	-------

Bolt ISO 4017 M20 x 100-8.8, galv.

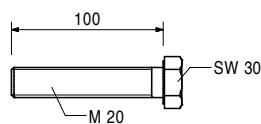
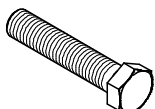

RCS-C Rail Climbing Formwork

Item no.	Weight kg	
104477	0.300	Bolt ISO 4014 M20 x 120-8.8, galv.

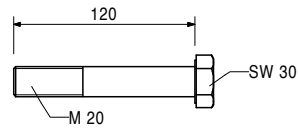
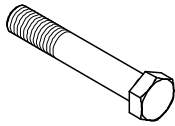

Accessories

781053	0.065	Nut ISO 7040 M20-8, galv.
--------	-------	----------------------------------

781053	0.065	Nut ISO 7040 M20-8, galv. Self-locking.
--------	-------	---

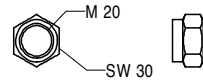

109612	0.600	Bolt ISO 4014 M24 x 130-8.8, galv.
--------	-------	---

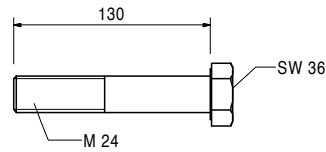
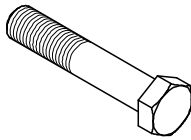

105032	0.070	Nut ISO 7040 M24-8, galv. Self-locking.
--------	-------	---

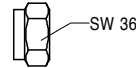

		F.H. Bolts DIN 603	L	B
051650	0.060	F.H. Bolt DIN 603 M6 x 180 MU, galv.	180	24
024140	0.033	F.H. Bolt DIN 603 M8 x 70 MU, galv.	70	58
710240	0.050	F.H. Bolt DIN 603 M8 x 100 MU, galv.	100	80
024390	0.090	F.H. Bolt DIN 603 M8 x 200 MU, galv.	200	150
024410	0.109	F.H. Bolt DIN 603 M8 x 250 MU, galv.	250	150

With nut.

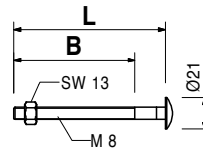

RCS-C Rail Climbing Formwork

Item no.	Weight kg	
780354	0.002	Washer ISO 7089 200 HV, A 8, galv.



024540	0.005	TSS-Torx 6	L
024470	0.008	TSS-Torx 6 x 40, galv.	40
024690	0.008	TSS-Torx 6 x 60, galv.	60
		TSS-Torx 6 x 80, galv.	80
For Torx Bits TX 30. Self-drilling.			

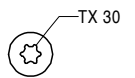
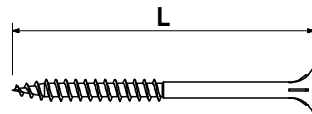
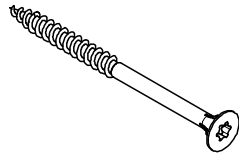

111437	0.004	Spax Screws TX25	L
110642	0.006	Spax Screw TX25, 5 x 20, yellow galv.	20
		Spax Screw TX25, 5 x 40, yellow galv.	40

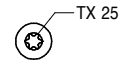
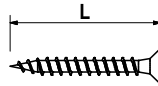
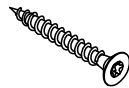

024950	0.012	Spax Screw TX 30 6 x 100, yellow galv.
For Torx Blade TX 30. Self-drilling.		

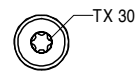
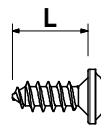
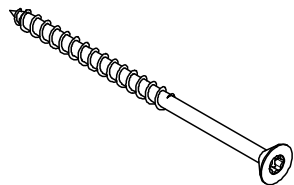

Item no.	Weight kg		L
051640	0.014	Lag Screwn DIN 571	80
024270	0.023	Lag Screw DIN 571 6 x 80, galv.	60
024260	0.027	Lag Screw DIN 571 8 x 60, galv.	80

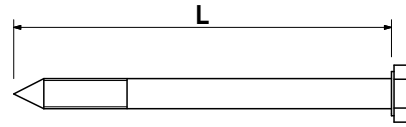
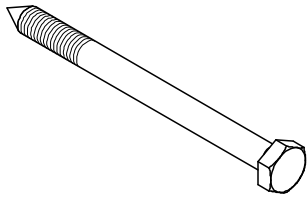

127320	158.000	Lifting Beam 9 t	
		For moving climbing units.	

Complete with

- 1 pc. 112865 Bolt 25 x 180
- 1 pc. 022230 Cotter Pin 5/1, galv.
- 1 pc. 107297 Bolt ISO4014-M12 x 140-8.8, galv.
- 1 pc. 710330 Nut ISO 4032 M12-8, galv.

Note

Follow Instructions for Use.

Technical Data

Permissible load-bearing capacity 9 t.

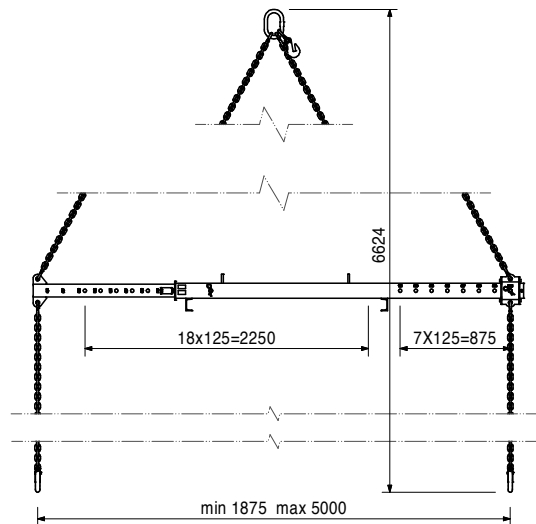
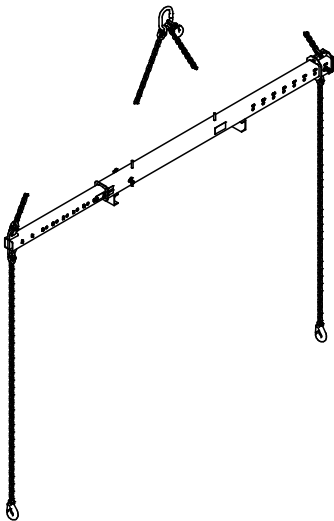

RCS-C Rail Climbing Formwork



Item no.	Weight kg
127834	2.210

Crane Eye BR-2 2.5 t, galv.

As attachment point for moving climbing systems or Platform Beam BR.

Note

Follow Instructions for Use!

Technical Data

Permissible load-bearing capacity 2.5 t.

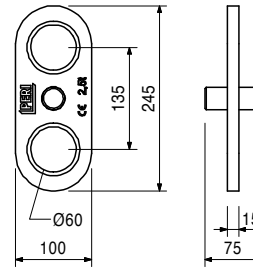

Accessories

020620	0.561
--------	-------

Spacer for Platform Beam BR

113745	30.200
--------	--------

Climbing Rail Extension RCS 125

For extending the Climbing Rail RCS and using the Climbing Device RCS 50 on the working platform.

Complete with

- 4 pc. 110022 Spacer M20-82
- 2 pc. 111567 Fitting Pin \varnothing 26 x 120
- 2 pc. 022230 Cotter Pin 5/1, galv.

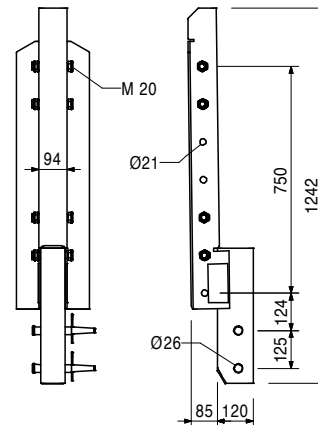
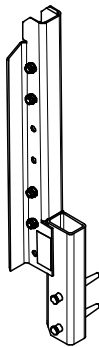

116469	5.920
--------	-------

Wheel RCS 1.5 t

For assembling in Climbing Rails RCS, foldable.

Complete with

- 2 pc. 113012 Pin \varnothing 20 x 260, galv.
- 2 pc. 018060 Cotter Pin 4/1, galv.

Technical Data

Permissible load-bearing capacity 1.5 t.

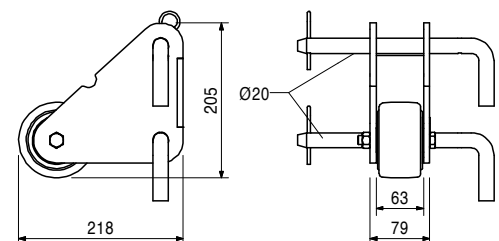
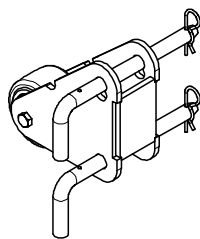

Item no.	Weight kg
114317	3.210

Guide in Tool RCS

For pulling up the Climbing Rail RCS in order to close the folding runners of the Climbing Shoe.

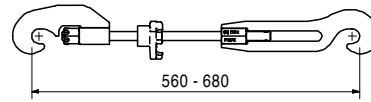
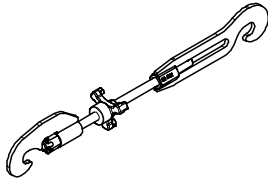

109468	19.800
--------	--------

Climbing Shoe RCS

Guide and support for Climbing Rail RCS. With foldable leading runners and self-actuating bearing pawl.

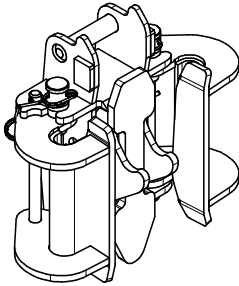

Complete with

- 2 pc. 116067 Locking Device
- 2 pc. 109902 Pin \varnothing 30 x 290, galv.
- 4 pc. 711063 Dowel Pin \varnothing 5 x 35
- 2 pc. 109508 Pin \varnothing 16 x 239, galv.
- 4 pc. 750329 Dowel Pin \varnothing 5 x 20
- 1 pc. 109903 Spring Lock

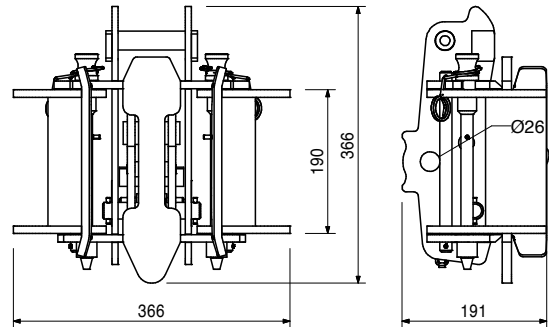

135962	0.379
--------	-------

Climbing Shoe Display RCS MAX

For use as Climbing Shoe Display RCS

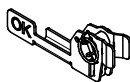

Complete with

- 1 pc. 711071 Nut ISO 7040 M8-8, galv.
- 1 pc. 126908 bolt ISO 4014 M8 x 45-8.8, galv.

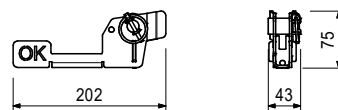

Accessories

109468	19.800
--------	--------

Climbing Shoe RCS

109503	7.380
--------	-------

Wall Shoe RCS

Anchor System M30. For anchoring Climbing Shoe RCS to the wall.

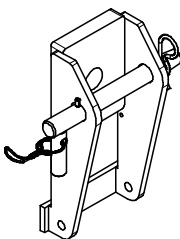

Complete with

- 1 pc. 715585 Pin \varnothing 25 x 240, SKS, galv.
- 1 pc. 022230 Cotter Pin 5/1, galv.

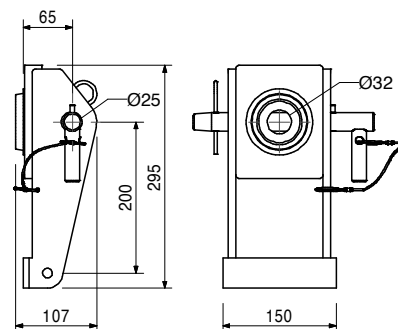

Accessories

029420	0.590
--------	-------

Bolt ISO 4017 M30 x 70-8.8, galv.

RCS-C Rail Climbing Formwork

Item no.	Weight kg
110667	13.700

Wall Shoe RCS, pivoted

Anchor System M30. For anchoring Climbing Shoe RCS to circular walls. Swivel range $\pm 15^\circ$.

Complete with

1 pc. 715585 Pin $\varnothing 25 \times 240$, SKS, galv.
1 pc. 022230 Cotter Pin 5/1, galv.

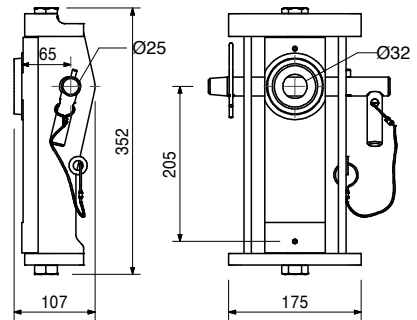
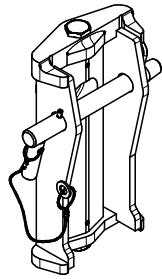

Accessories

113007	0.700
--------	-------

Cyl. Bolt ISO 4762 M30 x 70-8.8, galv.

110315	11.000
--------	--------

Mounting Ring Adapter RCS M30

For suspension with Scaffold Mounting Ring M30 during use as unguided climbing formwork.

Complete with

1 pc. 715585 Pin $\varnothing 25 \times 240$, SKS, galv.
2 pc. 104031 Fitting Pin $\varnothing 21 \times 120$
2 pc. 018060 Cotter Pin 4/1, galv.

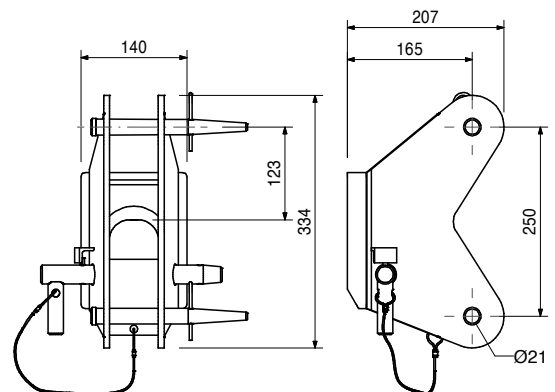
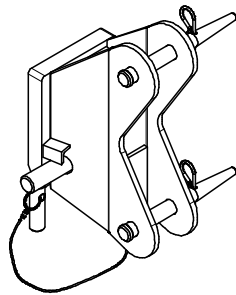

Accessories

029480	1.830
--------	-------

Scaffold Mounting Ring M30, galv.

029480	1.830
--------	-------

Scaffold Mounting Ring M30, galv.

Anchor System M30.
For anchoring climbing systems.

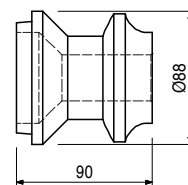
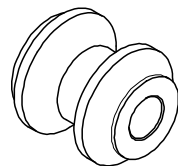

Accessories

029540	0.920
--------	-------

Bolt ISO 4014 M30 x 130-10.9, galv.

RCS-C Rail Climbing Formwork

Item no.	Weight kg
030920	1.650

Climbing Cone-2 M30/DW 20, galv.
Anchor System M30.
For anchoring climbing systems.

Note
Separate Design Information on request.

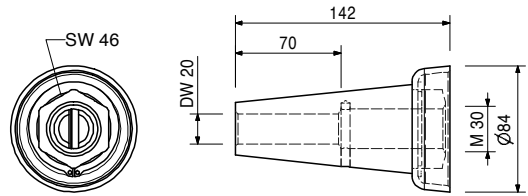
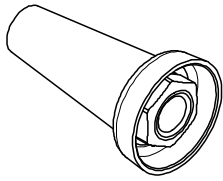

Accessories

030860	0.792
030700	2.560
030745	2.600

Threaded Anchor Plate DW 20
Tie Rod DW 20, spec. length
Tie Rod B 20, spec. length

030860	0.792
--------	-------

Threaded Anchor Plate DW 20
For use with Tie Rod DW 20, B 20 or Screw-On Cone-2 M24/DW 20. For anchoring in concrete.

Note
Lost anchor part.

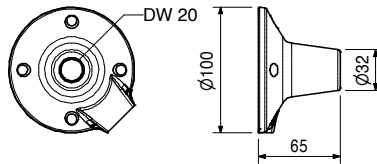
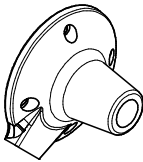

030700	2.560
030800	0.000

Tie Rod DW 20
Tie Rod DW 20, spec. length
Cutting Cost Tie Rod DW 20/B 20

Note
Non-weldable! Take official Approval into consideration!

Technical Data
Permissible tension force 150 kN.

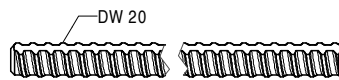
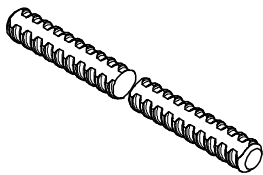

030745	2.600
030800	0.000

Tie Rod B 20
Tie Rod B 20, spec. length
Cutting Cost Tie Rod DW 20/B 20

Note
Weldable! Take official Approval into consideration!

Technical Data
Permissible tension force 150 kN.

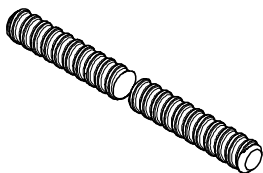

RCS-C Rail Climbing Formwork



Item no.	Weight kg
057257	1.810

Screw-On Cone M30/DW 26, galv.
Anchor System M30.
For anchoring climbing systems.

Note
Permissible load see PERI Product Information.

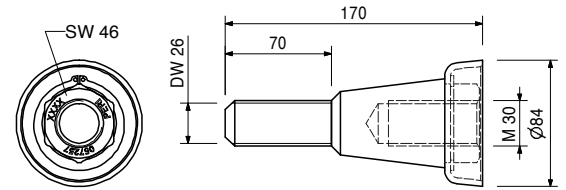
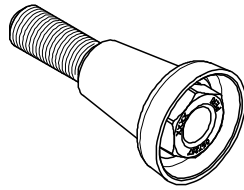

Accessories

030870	1.260
--------	-------

Threaded Anchor Plate DW 26

030870	1.260
--------	-------

Threaded Anchor Plate DW 26
For use with Tie Rod DW 26 or Screw-On Cone M36/DW 26. For anchoring in concrete.

Note
Lost anchor part.

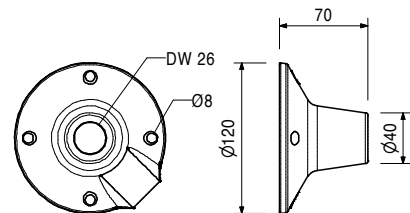
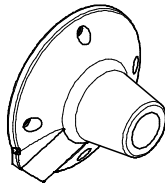

031653	0.364
--------	-------

KK Concrete Cone M30-80/52
For closing anchor points with Climbing Cone-2 M30/DW 20 or Screw-On Cone M30/DW 26.

Note
Delivery unit 50 pieces.

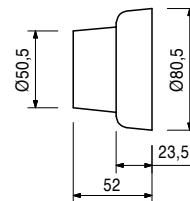
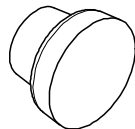

Accessories

131709	9.980
--------	-------

Sealing Compound-3, 6 cans-set

131709	9.980
--------	-------

Sealing Compound-3, 6 cans-set
For bonding PERI Concrete Cones.

Note
See Safety Data sheet!
Consisting of:
6 x Component A, 6 x Component B

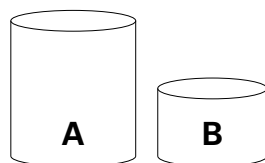

Item no. Weight kg

029380 0.200

Anchor Positioning Plate M30, galv.

For fixing the M30 Anchor System if the plywood formlining is drilled through.

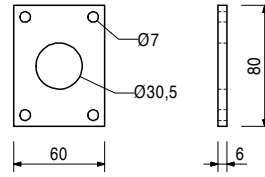
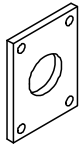

Accessories

029440 0.005

Lag Screw DIN 571 6 x 20, galv.

029450 0.339

Advancing Screw M30, galv.

For fixing the M30 Anchor System if the plywood formlining is drilled through.

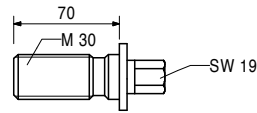
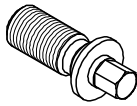

Accessories

029380 0.200

Anchor Positioning Plate M30, galv.

029420 0.590

Bolt ISO 4017 M30 x 70-8.8, galv.

Bolt for anchoring of climbing systems.

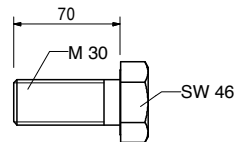
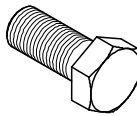

Accessories

029380 0.200

Anchor Positioning Plate M30, galv.

029540 0.920

Bolt ISO 4014 M30 x 130-10.9, galv.

High-strength bolt for anchoring climbing systems.

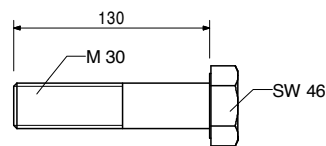
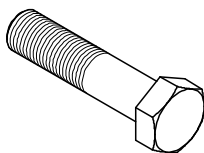

RCS-C Rail Climbing Formwork



Item no.	Weight kg
109765	27.000

Climbing Device RCS 50
For crane-independent climbing of RCS Climbing Units.

Note
Follow Instructions for Use!
Technical Data
Maximum lifting capacity 50 kN.

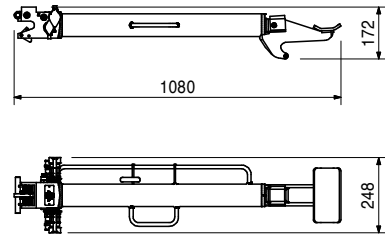
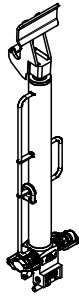

109766	109.000
--------	---------

Hydraulic Pump RCS 4-fold, 380 – 460 V
Hydraulic pump for actuating the Climbing Device RCS 50 and LPS 30.

Note
Follow Instructions for Use.
Use only original PERI Hydraulic Oil HV LP46.

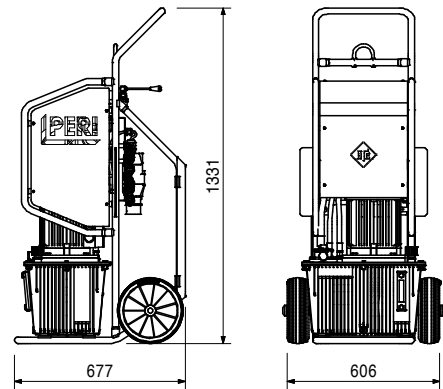
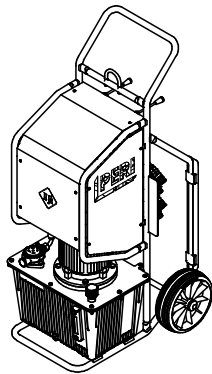

Accessories

057376	18.300
--------	--------

Hydraulic Oil ISO 11158 HVI46, 20 l

057376	18.300
--------	--------

Hydraulic Oil ISO 11158 HVI46, 20 l
High quality synthetic hydraulic oils for PERI Hydraulic Units.

Note
Observe the safety data sheet and applicable national safety regulations regarding hydraulic oil, in particular for transport, storage and disposal! Observe the technical documentation for the hydraulic unit!
Product data sheet on request.

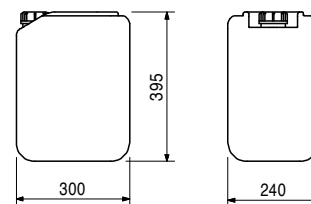

Item no.	Weight kg	
110069	8.500	Hydraulic Twin Hoses RCS
110070	15.300	Hydraulic Twin Hose RCS, 10 m Hydraulic Twin Hose RCS, 20 m

Two permanently connected hydraulic hoses for connecting hydraulic pumps with hydraulic climbing devices.

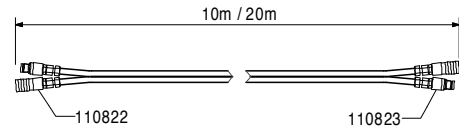
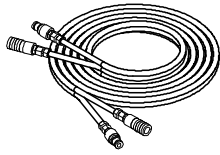

Complete with
 2 pc. 128992 Pin ISO16028 DN10 R3/8IG
 2 pc. 128993 Sleeve ISO16028 DN10 R3/8IG
 4 pc. 051750 Male Stud Coupler X-GE12PSR-ED

110280	0.500	Adapter Cable RCS For the power supply to the Hydraulic Pump RCS.	Note Follow Instructions for Use! With CEE plug connector 400 V 16 A.
--------	-------	---	--

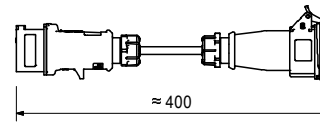
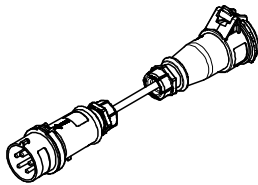

110279	0.250	Plug Socket RCS, black For providing the power supply to the Hydraulic Pump RCS with 380 – 460 V, 50 – 60 Hz.	Note Follow Instructions for Use!
--------	-------	---	---

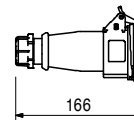

			L
072180	0.560	Ratchet Wrench	300
051764	2.650	Ratchet Wrench 1/2"	630
029610	5.300	Ratchet Wrench 3/4" Ratchet Wrench 1"	900

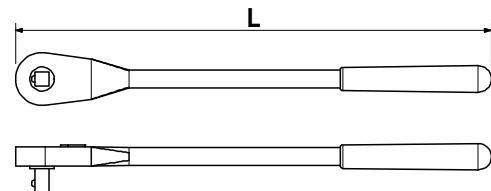
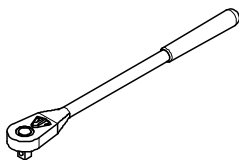

RCS-C Rail Climbing Formwork

Item no. Weight kg

		Sockets SW
029620	0.075	Socket SW 19-1/2"
057276	0.625	Socket SW 30-3/4"
102785	0.452	Socket SW 36-3/4"
029630	0.580	Socket SW 46-1"
Fits to Hex. Bolts M12 or Height Adjusting Unit SW 19.		

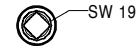

110094	0.895	Carriage Crank Lever SW 19 For operating the Carriage RCS.
--------	-------	--

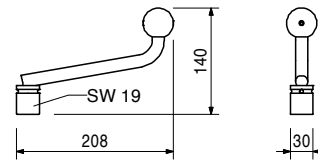
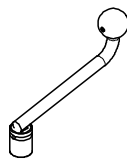

110950	4.760	Excentric Lever RCS For dismantling Climbing Shoe RCS.
--------	-------	--

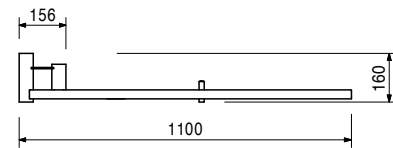
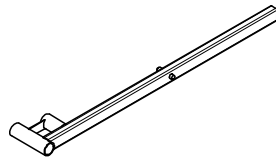

109716	107.000	Crossbeam RCS 220 Spare part. Platform beam for formwork scaffolding with Carriage RCS.
--------	---------	--

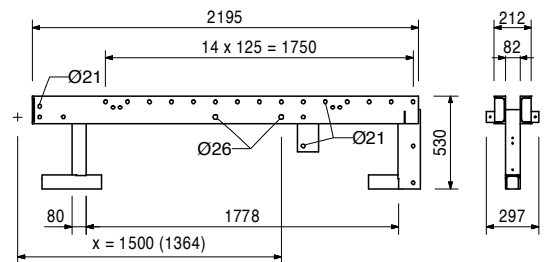
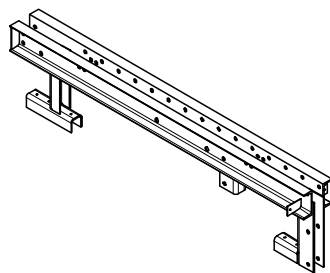

Accessories		
110015	10.400	Crossbeam Head RCS/VARIO
110285	7.920	Crossbeam Head RCS/TRIO
109968	41.500	Carriage RCS

RCS-C Rail Climbing Formwork



Item no.	Weight kg
110015	10.400

Crossbeam Head RCS/VARIO

Spare part.
For connecting the Crossbeam RCS 220 to the Climbing Rail RCS when using VARIO GT 24 formwork (x = 1500).

Complete with

- 1 pc. 109612 Bolt ISO 4014 M24 x 130-8.8, galv.
- 1 pc. 105032 Nut ISO 7040 M24-8, galv.
- 3 pc. 104477 Bolt ISO 4014 M20 x 120-8.8, galv.
- 3 pc. 781053 Nut ISO 7040 M20-8, galv.

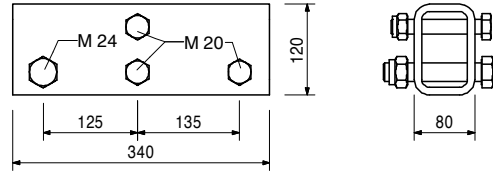
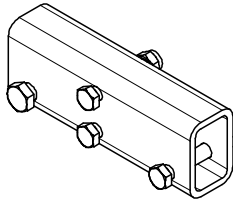

109968	41.500
--------	--------

Carriage RCS

Spare part.
Self-locking carriage with roller bearings on the Crossbeam RCS 220. Formwork moveable by max. 88 cm.

Complete with

- 4 pc. 104477 Bolt ISO 4014 M20 x 120-8.8, galv.
- 4 pc. 781053 Nut ISO 7040 M20-8, galv.

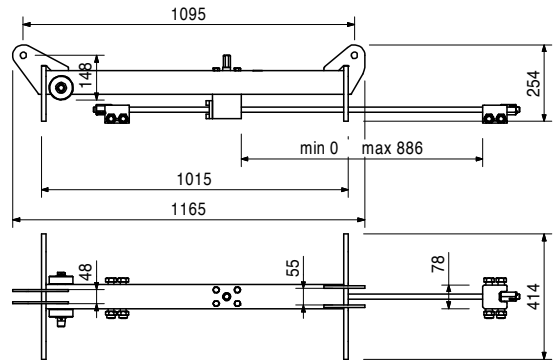
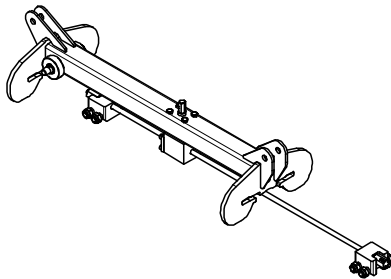

Accessories

110094	0.895
--------	-------

Carriage Crank Lever SW 19

117585	24.300
116478	37.000
116479	61.500
116480	86.300
113705	98.700
116481	124.000
116482	186.000
116483	248.000

Climbing Rail Profiles RCS

- Climbing Rail Profile RCS 98
- Climbing Rail Profile RCS 148
- Climbing Rail Profile RCS 248
- Climbing Rail Profile RCS 348
- Climbing Rail Profile RCS 398
- Climbing Rail Profile RCS 498
- Climbing Rail Profile RCS 748
- Climbing Rail Profile RCS 998

L

- 980
- 1480
- 2480
- 3480
- 3980
- 6980
- 7480
- 9980

Steel profile for all-purpose use of climbing application or civil constructions. Single profile.

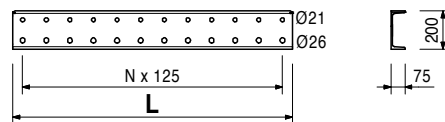
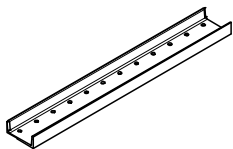

Accessories

110022	0.491
110023	0.910

- Spacer M20-82
- Spacer M24-82

Item no.	Weight kg
115581	10.280

Hydraulic Service Case

Consisting of:

- 1 pc. 115590 Tool Box 580 x 260 x 285 mm
- 6 pc. 115583 Pressure Gauge Typ 570 VA-Geh.
- 6 pc. 115584 Hose MKT 6-02 DN 02
- 12 pc. 115582 Measuring Coupl. SMK 20-G 1/4-PC
- 2 pc. 115591 Double Spanner SW 10 x 13
- 1 pc. 115592 Double Spanner SW 13 x 17
- 1 pc. 115588 Double Spanner SW 19 x 24
- 1 pc. 051778 Double Spanner SW 24 x 27
- 1 pc. 115589 Double Spanner SW 27 x 32
- 1 pc. 057278 Allen Key Set, 8 pcs.
- 1 pc. 115585 Allen Key SW 12
- 1 pc. 057279 Allen Key SW 14
- 1 pc. 057282 Pipe Wrench
- 1 pc. 115147 Angle Fitting Set PS
- 2 pc. 115396 Fitting Set PS
- 1 pc. 072180 Ratchet Wrench 1/2"
- 20 pc. 123881 Tube Screw Plug ROV12SX
- 20 pc. 123880 Threaded Plug VKAN 12S VIT
- 100 pc. 051760 Cable Binder NT-240H
- 2 pc. 126425 Distance Piece Ø 120
- 1 pc. 126440 Socket SW 17 - 1/2"
- 1 pc. 135172 Double Spanner SW 19 x 22
- 1 pc. 135173 Allen Key SHR-Bit SW 05
- 1 pc. 135174 Allen Key SHR-Bit SW 06
- 1 pc. 135175 Allen Key SHR-Bit SW 08
- 1 pc. 135176 Allen Key SHR-Bit SW 10
- 1 pc. 135177 SHR Screwdriver Bit 6 Tl. Slot/PH
- 2 pc. 711035 Adhesive Label 128 x 65 mm
- 1 pc. 126434 List of contents Hydraulic Service Case

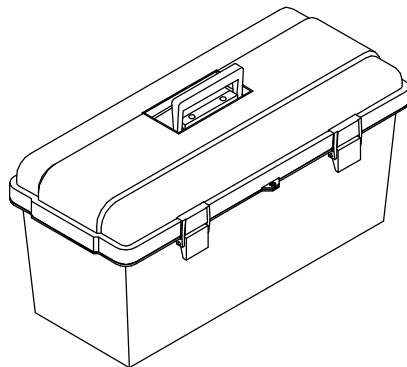

125632	0.050
--------	-------

Protect. Covers Climb. Device RCS

To protect unplugged quick couplings X-GE 12PSR-ED+ against dirt and damage.

Technical Data

1 set for 1 Climbing Device RCS 50 (2x bushing and 2x nipple each).

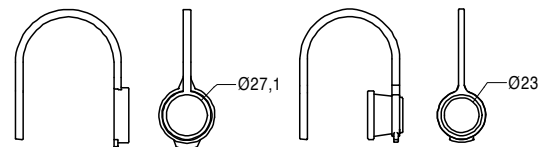
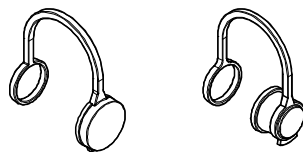

Item no.	Weight kg	
110823	0.171	Quick Coupler Nipple RCS

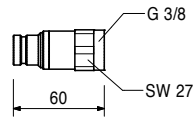

110822	0.297	Quick Coupler Bushing RCS
--------	-------	----------------------------------

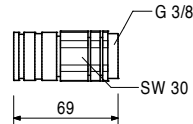
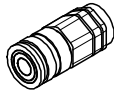

115147	0.750	<p>Angle Fitting Set PS Conversion set for 1 cylinder (item-no. 109765 Climbing Device RCS50) to arrange quick couplers vertically on one side.</p>	<p>Note consisting of: 2 pc. Screw Plug K006.080 2 pc. Angle Screwing K018.740 2 pc. Screwing K018.294 1 pc. Hose Safety Device 109.063G.00.015</p>
--------	-------	--	--

115396	0.720	<p>Fitting Set PS Spare fitting set for 1 cylinder (item-no. 109765 Climbing Device RCS 50) for Quick Coupler Bushings and Nipples.</p>	<p>Note consisting of: 4 pc. Screwing G 3/8 - G 3/8 2 pc. Dust Cover Nipple 2 pc. Dust Cover Bushing</p>
--------	-------	--	---

126431	12.300	<p>Hatch 55 x 60-2, foldable Self-closing hatch for ladder access. Clear opening approx. 55 x 60 cm. Ladder fixation with bolts or by hanging up.</p>	<p>Complete with 1 pc. 126785 Hatch Hinge RCS 12 pc. 108647 Rivet DIN 7337- A5 x 20 2 pc. 022230 Cotter Pin 5/1, galv.</p>
--------	--------	--	---

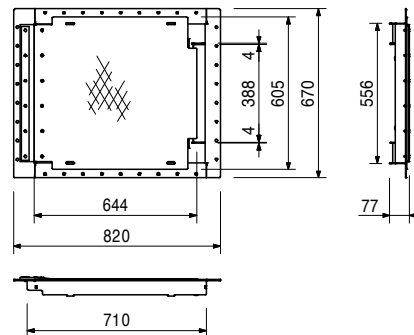
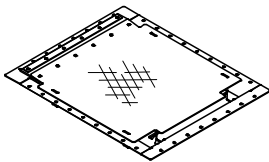

710224	0.047	Accessories
710381	0.017	<p>Bolt ISO 4017 M12 x 40-8.8, galv. Nut ISO 7042 M12-8, galv.</p>

RCS-C Rail Climbing Formwork



Item no.	Weight kg
110608	15.600

Hatch 55 x 60, foldable

Self-closing hatch for ladder access. Clear opening approx. 55 x 60 cm. Ladder fixation with bolts.

Complete with

- 1 pc. 110529 Hinging Plate left, galv.
- 1 pc. 110535 Hinging Plate right, galv.
- 8 pc. 721412 Rivet DIN 7337 - A4,8 x 12

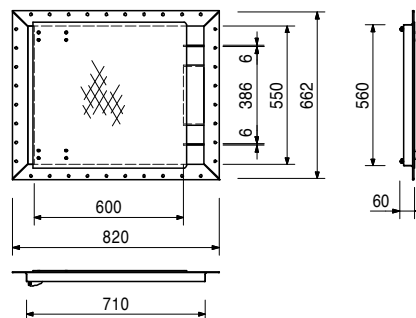
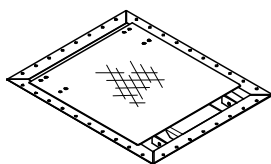

Accessories

710224	0.047
710381	0.017

Bolt ISO 4017 M12 x 40-8.8, galv.

Nut ISO 7042 M12-8, galv.

051430	37.900
--------	--------

Sliding Hatch Cover

Non self-closing hatch for ladder access. Clear opening approx. 73 x 55 cm. Ladder fixation with bolts.

Complete with

- 4 pc. 710266 Bolt ISO 4017 M12 x 25-8.8, galv.
- 4 pc. 710381 Nut ISO 7042 M12-8, galv.

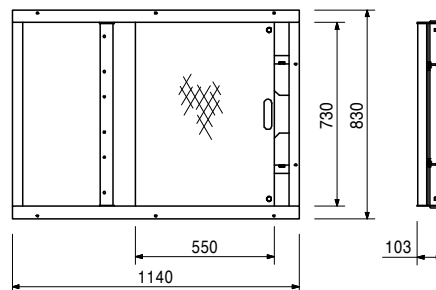
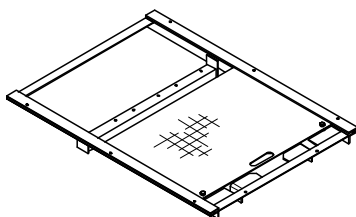

051410	11.700
--------	--------

Ladder 180/6, galv.

As access for PERI Formwork Systems.

Complete with

- 4 pc. 710224 Bolt ISO 4017 M12 x 40-8.8, galv.
- 4 pc. 710381 Nut ISO 7042 M12-8, galv.

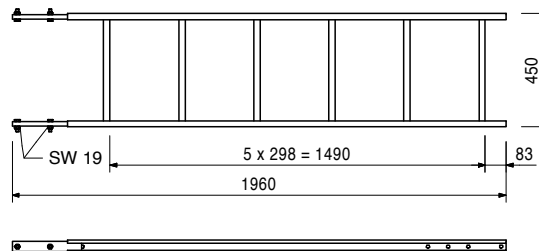
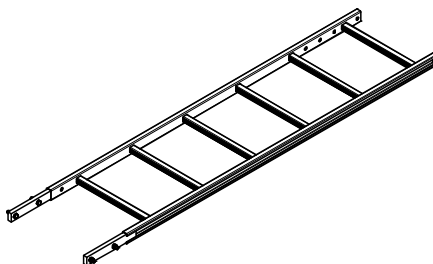

RCS-C Rail Climbing Formwork



Item no.	Weight kg
051420	12.800

Ladder 220/6, galv.
As access for PERI Formwork Systems.

Complete with
4 pc. 710224 Bolt ISO 4017 M12 x 40-8.8, galv.
4 pc. 710381 Nut ISO 7042 M12-8, galv.

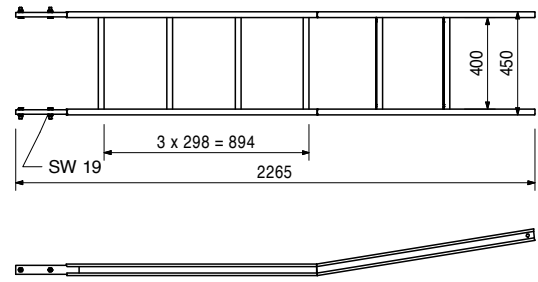

103724	10.400
--------	--------

End Ladder 180/2, galv.
As access for PERI Formwork Systems.

Complete with
4 pc. 710224 Bolt ISO 4017 M12 x 40-8.8, galv.
4 pc. 710381 Nut ISO 7042 M12-8, galv.

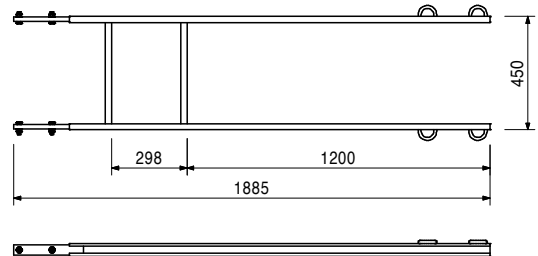
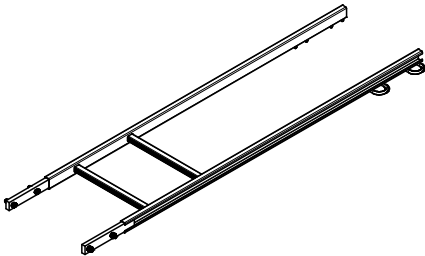

109105	5.070
--------	-------

Ladder Base 30 adjustable, galv.
For horizontal fixing of ladders on the platform decking.

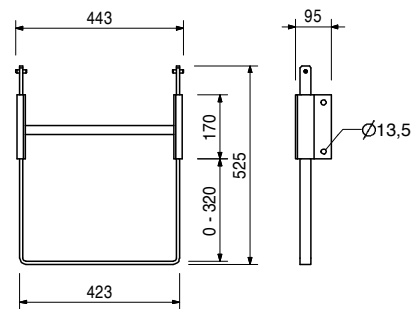

051460	2.180
--------	-------

Ladder Base, galv.
As bottom ladder connection and for securing ladders against sliding on the scaffold decks.

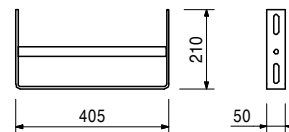
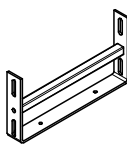

RCS-C Rail Climbing Formwork

Item no.	Weight kg
103718	0.684

Ladder Hook, galv.
 For adjusting the bottom ladder.
 Always use in pairs.

Complete with
 2 pc. 710266 Bolt ISO 4017 M12 x 25-8.8, galv.
 2 pc. 710381 Nut ISO 7042 M12-8, galv.

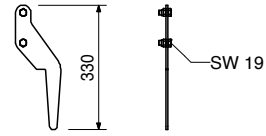

104132	15.600
051450	25.200

Ladder Safety Cages, galv.
Ladder Safety Cage 75, galv.
Ladder Safety Cage 150, galv.
 Ladder safety cage for PERI Access Ladders.

Complete with
 4 pc. 710266 Bolt ISO 4017 M12 x 25-8.8, galv.
 4 pc. 701763 Clamping Plate FI 25 x 10 x 90

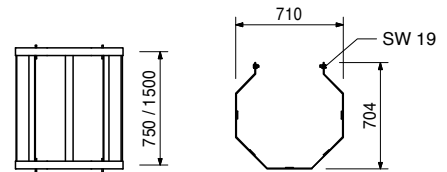
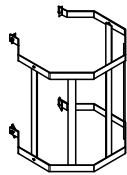

710224	0.047
--------	-------

Bolt ISO 4017 M12 x 40-8.8, galv.
 As access for PERI formwork systems.

L
 40

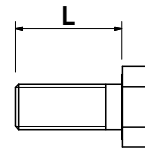
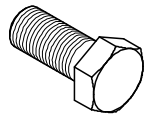

710381	0.017
--------	-------

Nut ISO 7042 M12-8, galv.
 Self-locking.

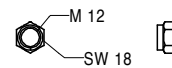

Item no.	Weight kg		L
075100	5.300	Girder GT 24	918
075120	7.100	Girder GT 24, l = 0.90 m	1214
075150	8.900	Girder GT 24, l = 1.20 m	1510
075180	10.600	Girder GT 24, l = 1.80 m	1806
075210	12.400	Girder GT 24, l = 2.10 m	2102
075240	14.200	Girder GT 24, l = 2.40 m	2398
075270	15.900	Girder GT 24, l = 2.70 m	2694
075300	17.700	Girder GT 24, l = 3.00 m	2990
075330	19.500	Girder GT 24, l = 3.30 m	3286
075360	21.200	Girder GT 24, l = 3.60 m	3582
075390	23.000	Girder GT 24, l = 3.90 m	3878
075420	24.800	Girder GT 24, l = 4.20 m	4174
075450	26.600	Girder GT 24, l = 4.50 m	4470
075480	28.300	Girder GT 24, l = 4.80 m	4766
075510	30.100	Girder GT 24, l = 5.10 m	5062
075540	31.900	Girder GT 24, l = 5.40 m	5358
075570	33.600	Girder GT 24, l = 5.70 m	5654
075600	35.400	Girder GT 24, l = 6.00 m	5950

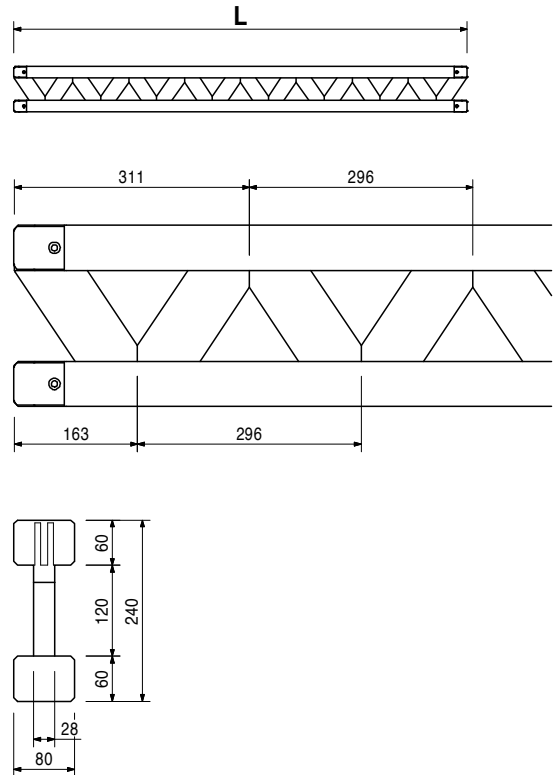
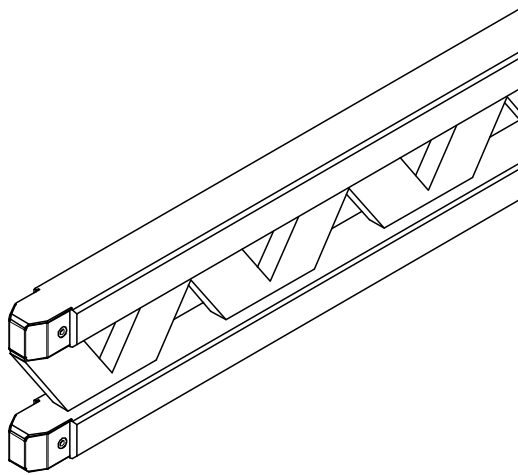

078010	36.875	Girder GT 24, l = 6.25 m
--------	--------	---------------------------------

RCS-C Rail Climbing Formwork

Item no.	Weight kg
026230	1.010

Anchor Sleeve M24
To anchor platform systems.

Note
Separate design information on request.

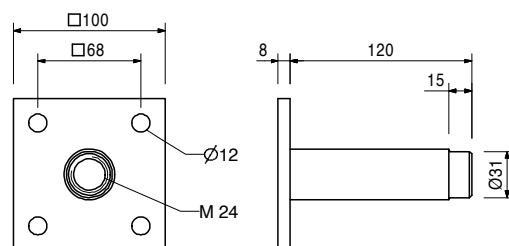
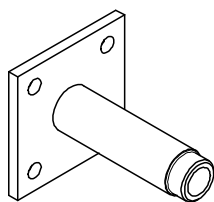

Accessories

026240	0.026	Cone PP Ø 31/26, c = 25
026250	0.005	Plug Ø 26 mm
116233	0.116	Cone FRC Ø 32/52, c = 40
026420	0.123	Anchor Positioning Stud M24, galv.
116234	0.033	Plug FRC Ø = 32
115150	0.200	Anchor Positioning Stud M24 x 65, galv.
123800	0.045	Metric Threaded Cone M24

031220 1.010 **Climbing Cone-2 M24/DW 15, galv.**
Anchor System M24.
For anchoring climbing systems.

Note
Separate design information on request.

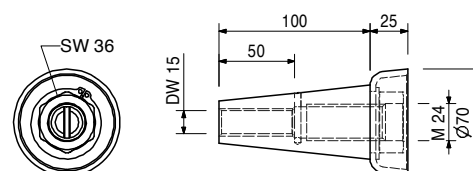
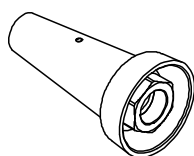

Accessories

030840	0.515	Threaded Anchor Plate DW 15
030030	1.440	Tie Rod DW 15, spec. length
030740	1.550	Tie Rod B 15, spec. length

065033 0.010 **Cone DR 22**
Plastic. Suitable for Spacer Tube DR 22.

Note
Delivery unit 500 pieces.

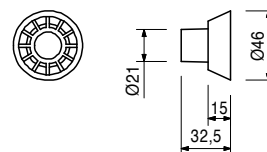

125856 2.580 **Scaffold Tube Adapter LPS/RCS Ø 48**
For assembling Scaffold Tubes Ø 48 to Climbing Rail RCS.

Complete with
1 pc. 017040 Screw-On Coupler AK 48, galv.
1 pc. 710894 Pin Ø 25 x 180, geomet.
2 pc. 018060 Cotter Pin 4/1, galv.

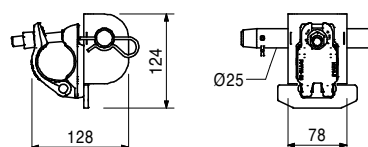
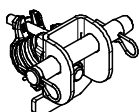

Item no.	Weight kg
051610	6.940

Side Guardrail Post CB

For assembly of an end guardrail. Bolted to the platform main beam.

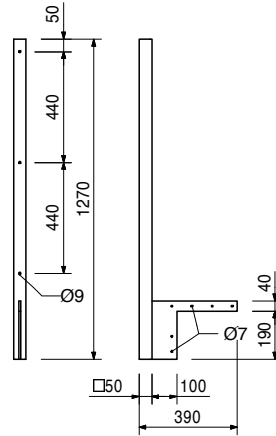

Accessories

051640	0.014
--------	-------

Lag Screw DIN 571 6 x 80, galv.

051160	1.050
--------	-------

Guardrail Connector CB

For assembling scaffold tubes on handrail posts.

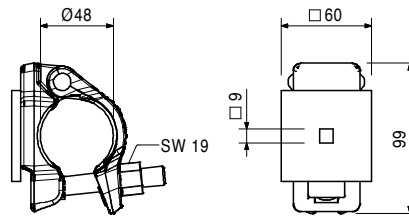
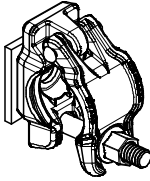

Accessories

126228	0.030
--------	-------

F.H. Bolt DIN 603 M8 x 70 MU, galv.

110598	0.142
--------	-------

Bolt ISO 4017 M12 x 140-8.8, galv.

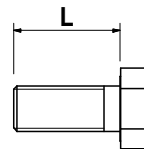
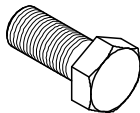

Item no.	Weight kg	
711084	0.420	Bolt ISO 4014 M20 x 150-8.8, galv.

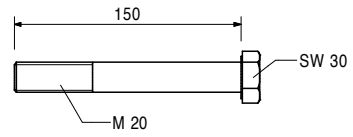
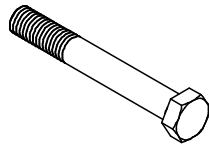

781053	0.065	Accessories Nut ISO 7040 M20-8, galv.
--------	-------	---

710342	0.007	Washer ISO 7093-1-08-200 HV, galv.
--------	-------	---

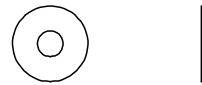

113348	0.043	Washer ISO 7094 100 HV, A 12, galv.
--------	-------	--

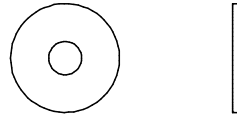
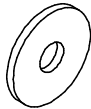

029440	0.005	Lag Screw DIN 571 6 x 20, galv.
--------	-------	--

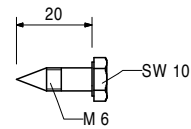

030370	1.660	Wingnut Pivot Plate DW 15, galv.
--------	-------	---

For anchoring with Tie Rod DW 15 and B 15. With pivoting captive nut. Maximum angle of tilting 8°.

Note
Wrench size SW 27.
Technical Data
Permissible load 90 kN.

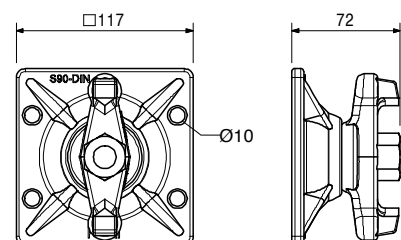
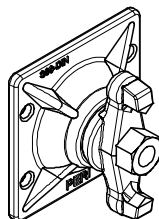

RCS-C Rail Climbing Formwork

Item no.	Weight kg
023650	0.769

Hook Tie DW 15, l = 400 mm, galv.
For connecting accessories to MAXIMO and TRIO Panels. DW 15 thread.

Technical Data
Permissible tension force 20.0 kN.

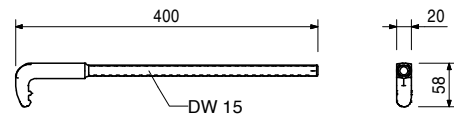
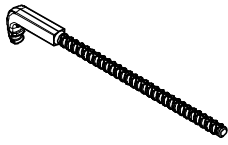

710312	0.005
--------	-------

Nail 3 x 80

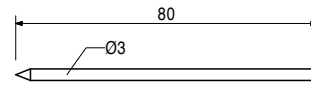
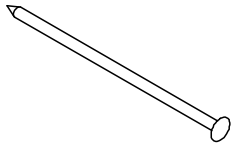

**The optimal System
for every Project and
every Requirement**



Wall Formwork



Column Formwork



Slab Formwork



Climbing Systems

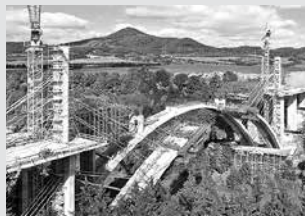

Bridge Formwork



Tunnel Formwork



Shoring Systems



Construction Scaffold



Facade Scaffold



Industrial Scaffold



Access



Protection Scaffold



Safety Systems



**System-Independent
Accessories**



Services



PERI Ltd
Formwork Scaffolding Engineering
 Market Harborough Road
 Clifton Upon Dunsmore
 Rugby
 Warwickshire
 CV23 0AN
 Tel. +44 (0)1788 861600
 info@peri.ltd.uk
 www.peri.ltd.uk