

RCS CL Rail Climbing System

Lightweight climbing formwork

Instructions for Assembly and Use – Standard Configuration – Version 1.0

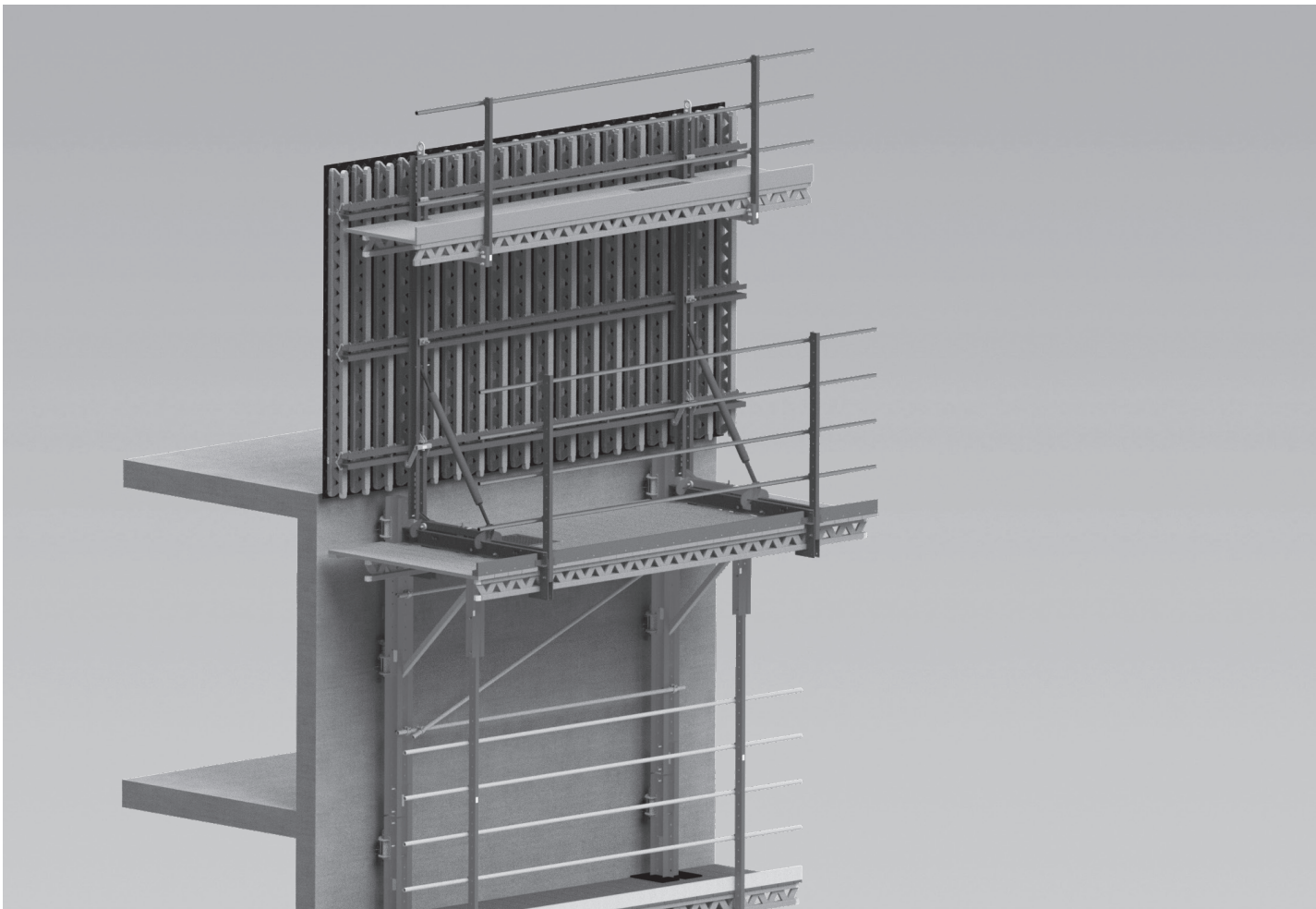

Overview

Main components	4
Key	6

Introduction

Target groups	7
Additional technical documentation	7
Product description	8
Instructions for Use	8
Cleaning and maintenance instructions	9

Safety instructions

Cross-system	10
System-specific	12

Component overview and tool list

Component overview	16
Tool list	17
Tightening torques	17

General information

A1 System overview	18
A2 Climbing device and hydraulics	22
General information	22
Climbing Device RCS 50	22
Hydraulic unit	23
Accessories	24
A3 Operating states and loads	26
Operating states and loads	26
A4 Standard work flow	28
Sequence of operation	28

Process planning

B1 Planning the shoring	32
System dimensions	32
Framework assembly	34
Additional spacers	35
Support reactions	36
B2 Planning the platforms	38
General	38
Platform beams	39
Finishing platform	41
Planking	42
Toe boards	42
Work platforms	43
Finishing platform	44
B3 Planning corner platforms	46
General information	46
Work platforms	46
Finishing platform	47
Concreting platform	48
B4 Planning round platforms	50
Parallel console bracket arrangement	50
Radial console bracket arrangement	51
B5 Planning guardrails	52
Guardrails	52
Lateral guardrails	54
Mounting the Handrail Boards	55
Installing the scaffolding tubes	55
B6 Planning requirements	58
Position of the leading tie	58
Planning the climbing sequence	59
Attachment point for crane	59
Repositioning with the Climbing Beam 9 t	60

Assembly

C1	Pre-assembling the formwork	62
	Strongback on TRIO Panel Formwork	62
	Strongback with Formwork Waler 150 CB	64
	Strongback on VARIO formwork	66
	Concreting platform	67
C2	Pre-assembling the console bracket unit	72
	Mounting the work platform	72
	Installing the lateral protection	74
	Preparing the climbing rail	75
C3	First concreting section	78
	Attaching the climbing rail	79
	Mounting the work platform	80
	Fitting formwork	81
	Fitting the leading tie	82
	Concreting	84
C4	Assembling the finishing unit	86
	General	86
	Pre-assembling the finishing platform	86
	Preparing the climbing rails	87
	Attaching the finishing platform	88
	Preparing the climbing procedure	89
	First climbing procedure	90
	Completing the finishing platform	91
	Recovering the suspension	92
	Finishing the climbing procedure	93
C5	Ladder access	94
	Ladders	94

Use

D1	Standard cycle work procedures	96
D2	Operating the formwork	102
	Operating the carriage	102
	Adjusting the formwork	103
D3	Leading tie	104
	Releasing the leading tie	104
D4	Suspension	106
	Fitting the suspension	106
	Dismantling the suspension	107
	Removing climbing cones	109
D5	Operating the climbing shoe	110
	Opening and closing the climbing shoe	110
	Activating and deactivating the climbing pawl	112
D6	Repositioning with the climbing device	114
	Safety instructions	114
	Hydraulic diagram	115
	Remedial measures for malfunctions	115
	Operating the hydraulic system	115
	Bleeding the hydraulic system	115
	Putting climbing hydraulics into operation	116
	Preparations	116
	Preparations	117
	Self-climbing procedure	118
	Concluding work	125
	Self-climbing the final unit	126
D7	Repositioning with the crane	128
	Safety instructions	128
	Preparations	129
	Moving procedure	130
	If climbed too far	133
Dismantling		
E1	Lifting out the climbing formwork	134
	General	134
	Dismantling formwork	134
	Lifting out the climbing unit	135
Program overview		
	RCS-CL Lightweight Climbing Formwork	140

Main components

- 1 Upper climbing rail
- 2 Lower climbing rail
- 7 Climbing Rail Extension RCS 125
- 20 Work platform
- 21 Crossbeam U160
- 24 Carriage RCS
- 28 Formwork spindle (Heavy-Duty Spindle SLS)
- 29 Ladder cage
- 33 Finishing platform
- 35 Strongback RCS/SRU
- 36 Concreting platform
- 40 Formwork
- 50 Climbing Shoe RCS
- 60 Climbing Device RCS 50
- 87 Scaffolding tube bracing

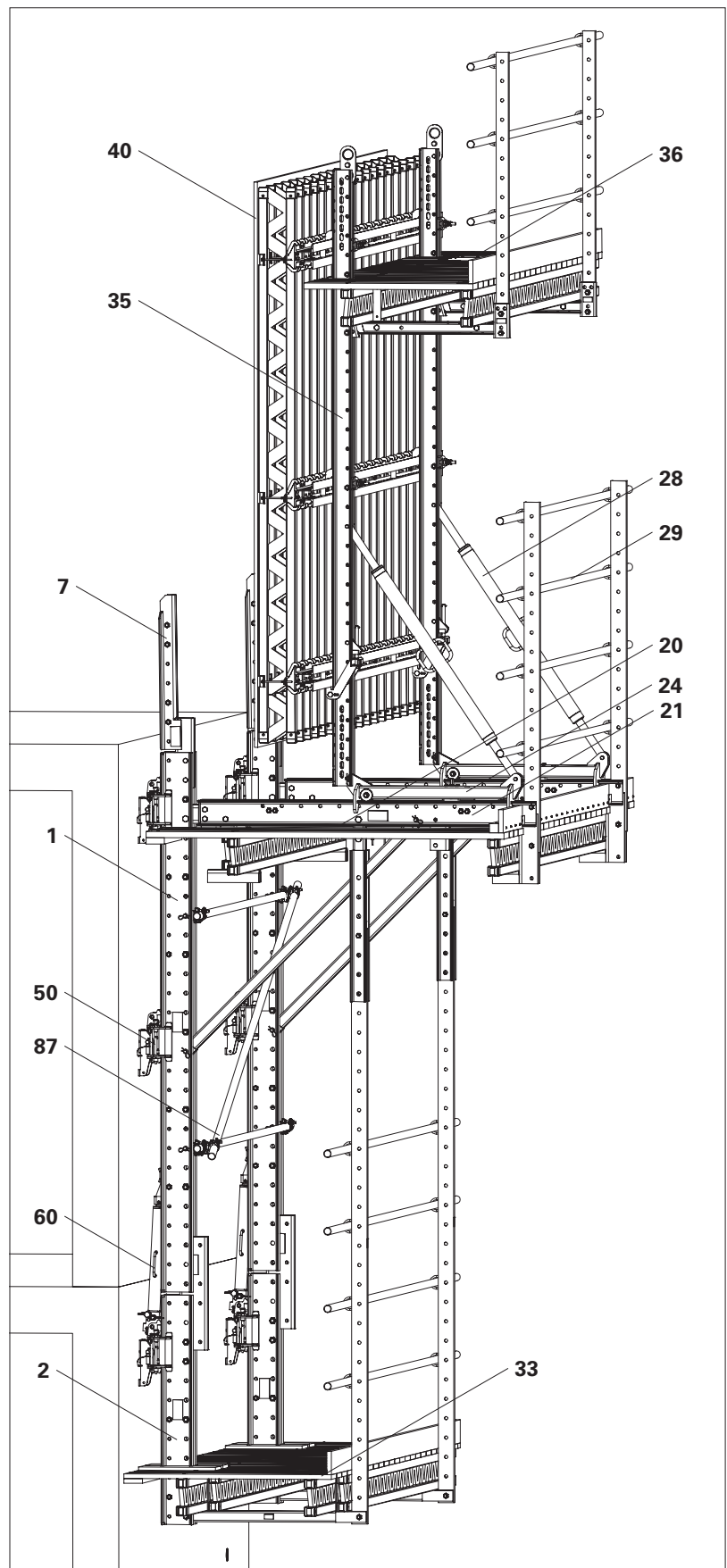

Key

Pictogram Definition



Danger/Warning/Caution



Note



To be complied with



Load-bearing point



Visual inspection



Tip



Incorrect use



Safety helmet



Safety shoes



Safety gloves



Safety goggles



Personal protective equipment to prevent falling from a height (PPE)

Arrows



Arrow representing an action



Arrow representing a reaction of an action*



Arrow representing forces

* If not identical to the action arrow.

Safety instruction categories

The safety instructions alert site personnel to the risks involved and provide information on how to avoid these risks. Safety instructions can be found at the beginning of the section or before instructions for action and are highlighted as follows:



Danger

This sign indicates an extremely hazardous situation that could result in death or serious, irreversible injury if the safety instructions are not followed.



Warning

This sign indicates a hazardous situation that could result in death or serious, irreversible injury if the safety instructions are not followed.



Caution

This sign indicates a hazardous situation that could result in minor or moderate injury if the safety instructions are not followed.



Note

This sign indicates situations in which failure to observe the information can result in material damage.

Format of the safety instructions



Signal word

Type and source of hazard!
Consequences of non-compliance.
⇒ Preventative measures.

Dimensions

Dimensions are usually given in cm. Other measurement units, e.g. m, are shown in the illustrations.

Conventions

- Instructions are numbered with: 1., 2., 3.
- The result of an instruction is shown by: →
- Position numbers are clearly provided for the individual components and are given in the drawing, e.g. **1**, in the text in brackets, for example **(10)**.
- Several position numbers, i.e. alternative components, are represented with a slash: e.g. **1/2**.

Notes on illustrations

The illustration on the front cover of these instructions is understood to be a system representation only. The assembly steps presented in these Instructions for Assembly and Use are shown in the form of examples with only one component size. They are valid for all component sizes contained in the standard configuration.

To facilitate understanding, detailed illustrations are sometimes incomplete. The safety equipment that might not be shown in these detailed illustrations must still be available.

Target groups

Contractors

These Instructions for Assembly and Use are designed for contractors who either

- assemble, modify and dismantle PERI systems, or
- use them, e.g. for concreting, or
- allow them to be used for other operations, e.g. carpentry or electrical work.

Competent person

(Construction Site Coordinator)

The Safety and Health Protection Coordinator*

- is appointed by the client,
- must identify potential hazards during the planning phase,
- determines measures that provide protection against risks,
- creates a safety and health protection plan,
- coordinates the protective measures for the contractor and site personnel so that they do not endanger each other,
- monitors compliance with the protective measures.

Competent persons qualified to carry out inspections

Due to the specialist knowledge gained from professional training, professional experience and recent professional activity, the competent person qualified to carry out inspections has a reliable understanding of safety-related issues and can carry out inspections correctly. Depending on the complexity of the inspection to be undertaken, e.g. scope of testing, type of testing or the use of certain measuring devices, a range of specialist knowledge is necessary.

Qualified personnel

PERI systems may only be assembled, modified or dismantled by personnel who are suitably qualified to do so. Qualified personnel must have completed a course of training** in the work to be performed, covering the following points at least:

- Explanation of the plan for the assembly, modification or dismantling of the formwork in an understandable form and language.
- Description of the measures for assembling, modifying or dismantling the formwork.

- Designation of the preventive measures to be taken to avoid the risk of persons and objects falling.
- Naming of the safety precautions in the event of changing weather conditions which could adversely affect the safety of the formwork system as well as the persons concerned.
- Details regarding permissible loads.
- Description of all other risks and dangers associated with assembly, modification or dismantling operations.



- **In other countries, ensure that the relevant national guidelines and regulations in the respective current version are complied with!**
- **If no country-specific regulations are available, it is recommended to proceed according to German guidelines and regulations.**
- **A competent person must be on site when any work is carried out on the climbing system as well as during the climbing procedure.**

* Valid in Germany: Regulations for Occupational Health and Safety on Construction Sites 30 (RAB 30).

** Instructions are given by the contractor themselves or a competent person selected by them.

Additional technical documentation

- Assembly Instructions:
 - RCS Climbing Device and Hydraulics
- Instructions for Use:
 - Climbing Beam 9 t
 - Lifting Eye BR-2 2.5 t
- Approvals:
 - Z-21.6-1766 PERI Screw-On Cone
 - Z-21.6-1767 PERI Climbing Cone
- Separate structural design information
- Design Tables 2015 – Formwork and Shoring

Product description

Regular assembly

These Instructions for Assembly and Use describe the standard assembly of the RCS CL Rail Climbing System as a formwork girder

- with finishing platform,
- with two climbing shoes per concreting section,
- self-climbing or rail-guided with the help of the crane,
- with Climbing Device RCS 50, installed from the work platform,
- maximum weight of a climbing unit: 9,000 kg.

Features

The RCS CL Formwork Scaffold is a standard application of the RCS Rail Climbing System.

The system is a bracket-like truss construction and is designed as shoring in accordance with DIN EN 12812 (formerly DIN 4421) to support wall formwork.

The climbing scaffold consists of 2 console discs (climbing rails with platform beams and struts) that are connected to the platforms (work platform and finishing platform) and scaffolding tube bracing. The platforms consist of a deck on platform beams. The platforms are pre-assembled on crossbeams (work platform) or finishing platform beams.

By connecting the formwork and the climbing scaffold by means of strongbacks, the climbing formwork is created, which is implemented as a self-climbing unit with the crane or with the hydraulic climbing device.

The vertical distances between the platforms can be selected using a 12.5 cm grid.

The RCS-CL Formwork Scaffold can also be equipped with an enclosure.

Intended use

- Formwork scaffolding in building construction projects,
- To provide anti-fall protection for site personnel,
- To protect workers from falling objects,
- To protect workers against the effects of the weather (only with enclosure).

PERI products have been designed for exclusive use in the industrial and commercial sectors only by suitably trained personnel.

Instructions for Use

Use in a way not intended, deviating from the standard configuration or the intended use according to the Instructions for Assembly and Use, represents a misapplication with a potential safety risk, e.g. risk of falling.

Only PERI original components may be used. Use of other products and spare parts is not allowed and represents a misapplication with associated safety risk.

Changes to PERI components are not permitted.

The system described in these Instructions for Assembly and Use may contain patent-protected components.

Foreseeable misuse

- Transportation/lifting of persons (exception: operating personnel required for the climbing procedure.)
- Transportation of loads, e.g. during assembly/dismantling or as a material lifter,
- Welding work (risk of fire),
- Flame-cutting operations (risk of fire),
- Working with a naked flame (fire hazard),
- Exceeding the permissible load-bearing capacity and load limits.
- Carrying out work in impermissible wind conditions.

Cleaning and maintenance instructions

In order to maintain the value and operational readiness of the materials over the long term, clean the panels after each use.

Some repair work will be inevitable due to the working conditions.

The following instructions should help to keep cleaning and maintenance costs as low as possible.

Spray components of the climbing system that are exposed to concrete contamination with concrete release agent before each use, this makes them easier and faster to clean.

Spray the concrete release agent very thinly and evenly.

Do not spray work platforms and access routes with concrete release agent.

Slip hazard.

Spray the climbing system with water immediately after concreting; this avoids any time-consuming and costly cleaning operations.

Mechanical components, e.g. climbing rails in the sliding area of the climbing shoes, spindles or gear mechanisms, must be cleaned of dirt or concrete residue before and after use, and then greased with a suitable lubricant.

Never clean powder-coated components, e.g. elements and accessories, with a steel brush or hard metal scraper; this ensures that the powder-coating remains intact.

Provide suitable support for the components during cleaning so that no unintentional change in their position is possible.

Do not clean components suspended on crane lifting gear.

Cross-system



Safety instructions apply to all service life phases of the system.

General information

The contractor must ensure that the Instructions for Assembly and Use supplied by PERI are available at all times and understood by the site personnel.

These Instructions for Assembly and Use can be used as the basis for creating a risk assessment. The risk assessment is compiled by the contractor. The Instructions for Assembly and Use are not a substitute for a risk assessment!

Observe and comply with the safety instructions and permissible loads.

For the application and inspection of PERI products, the current safety regulations and guidelines valid in the respective countries must be observed.

Materials and working areas are to be inspected before each use and assembly for:

- damage,
- stability and
- functional correctness.

Damaged components must be exchanged immediately on site and may no longer be used.

Safety components are to be removed only when they are no longer required.

When on slab formwork, scaffolds and working platforms:

- do not jump,
- do not run,
- do not drop anything from or onto it.

Components provided by the contractor must comply with the characteristics stipulated in these Instructions for Assembly and Use and all applicable laws and standards. Unless otherwise indicated, the following applies in particular:

- Timber components: Strength Class C24 for Solid Wood according to EN 338.
- Scaffolding tubes: galvanised steel tubing with minimum dimensions of $\varnothing 48.3 \times 3.2$ mm according to EN 12811-1:2003 4.2.1.2.
- Scaffolding tube couplings according to EN 74-1 and EN 74-2.

Deviations from the standard configuration are only permitted after a further risk assessment has been carried out by the contractor.

Appropriate measures for working and operational safety, as well as stability, are defined on the basis of this risk assessment.

Corresponding proof of stability can be provided by PERI on request if the risk assessment and resulting measures to be implemented are made available.

Before and after extraordinary events that may have damaging effects on the safety of the climbing system, the contractor shall immediately

- produce another risk assessment and make use of its results to take suitable steps to guarantee the stability of the climbing system,
- arrange for an extraordinary inspection to be carried out by a competent person qualified to do so. The aim of this inspection is to identify and rectify any damage in good time in order to guarantee safe use of the climbing system.

Exceptional events could be:

- accidents, fire,
- longer periods of non-use,
- natural events, e.g. heavy rainfall, icing, heavy snowfall, storms, lightning or earthquakes.

Assembly, modification and dismantling work

Assembly, modification or dismantling of climbing systems may only be carried out by qualified persons under the supervision of a competent person. The qualified personnel must have received appropriate training for the work to be carried out with regard to specific risks and dangers.

On the basis of the risk assessment and Instructions for Assembly and Use, the contractor must create installation instructions, in order to guarantee safe assembly, modification and dismantling of the climbing unit.



The contractor must ensure that the personal protective equipment required for the assembly, modification or dismantling of the climbing formwork, e.g.

- safety helmet,
- safety shoes,
- safety gloves,
- safety goggles,

is available and used as intended.



If personal protective equipment against falling from a height (PPE) is required or specified in local regulations, the contractor must determine appropriate attachment points on the basis of the risk assessment.

The PPE to be used to prevent falling is determined by the contractor.

The contractor must

- provide safe working areas for site personnel, which are to be reached through the provision of safe access ways. cordon off and clearly mark danger zones.
- guarantee stability during all stages of construction, in particular during assembly, modification and dismantling operations.
- ensure and demonstrate that all loads that occur are safely transferred.

Use

Every contractor who uses or allows the climbing systems to be used, is responsible for ensuring that the equipment is in good condition.

If the climbing system is used successively or at the same time by several contractors, the health and safety coordinator must point out any possible mutual hazards and all work must be then coordinated.

System-specific



Warning

In cases of leakage, hydraulic oil can escape at high pressure.

The oil can penetrate the skin and cause severe irreversible injuries.

⇒ Do not use parts of your body to cover the leakage.

⇒ Stay away from the leakage point.



Safety instructions apply to all service life phases of the system.

Make sure that the guardrails and/or edge covers at building openings and projections are fully installed before accessing the climbing/formwork system.

Strike components only when the concrete has sufficiently hardened and the person in charge has given the go-ahead for striking to take place.

Anchoring is to take place only if the anchorage has sufficient concrete strength.

Inspection of the anchoring and associated components must be carried out by the party responsible.

When the formwork is retracted, open building edges are created between the platforms. Cordon off or secure danger zones.

The enclosure of the platform or mounting of additional surfaces exposed to the wind changes the degree of stability and must be rechecked. If necessary, additional measures must be implemented.

Use a guide rope to ensure that assembly units suspended from the crane are fully under control when being moved.

Welding and/or abrasive cutting work must not be carried out on the platforms.

Reliable lightning conduction must be ensured by the contractor.

Assembly work

The contractor must ensure that the user has an appropriate and sufficient number of tools, lifting equipment and slings, a suitable and sufficient space for assembly and storage with a sufficient load-bearing capacity as well as adequate crane capacity at their disposal.

During the transportation procedure, only use the specified attachment points for components.

Avoid standing under suspended loads. If work under suspended loads cannot be avoided, come up with suitable safety measures and apply them. Avoid standing between a fixed object and an object that is drawing near.

Secure interim assembly states by means of temporary supports in order to prevent any items from toppling over.

Unexpected hazards can always arise when assembly work is carried out. Assess the degree of risk in each individual case and, if necessary, take measures to prevent or minimise the risk.

If guardrails cannot be used or has to be removed due to operational reasons, safety equipment must be installed in its place in order to prevent falls from any height.

If the use of anti-fall equipment is deemed to be inappropriate, personal protection equipment (PPE) can be used if suitable fixing points are available.

Site personnel are forbidden to remain in areas below where assembly work is being carried out, unless the danger zone has been provided with sufficient protection against falling, overturned, sliding or rolling objects.

Cordon off and clearly mark any danger zones and check that these are in place and complete every time work is commenced.

Do not walk on components and assembly units.

Find a secure standing position next to the components or assembly units. Use assembly scaffolds.

Always keep components and assembly units free of dirt, ice and snow.

Means of access

Safe access to all working areas must be guaranteed at all times.

Hatches and openings to accessible working areas must be kept closed during working operations.

Use walkways, stairs, stair towers or site lifts. Ladders are suitable for use as passageways in exceptional cases only.

Ladders must not be connected to each other for more than two levels and should be offset against one another.

Ladders must be secured on the outer side by means of appropriate anti-fall equipment such as ladder cages or safety nets.

Building edges at passages and openings in accessible areas must be secured.

In case of danger, it must be ensured that working areas can be vacated via emergency escape routes or rescue equipment.

It must also be ensured that at least one emergency escape route or piece of rescue equipment can still be used if the power supply fails.

Determine and apply all appropriate measures.

Throughout the entire relocation procedure, ensure that site personnel can still use the emergency escape route.

In case the access hatches are blocked when retracting the formwork, ensure that site personnel can still use the emergency escape route.

Protection against falling components

Work activities may not be carried out simultaneously on areas positioned on top of each other if the lower working areas are not protected against falling objects.

Avoid installing working areas and access routes in danger zones.

If this is not possible due to work procedures, suitable protective measures must be available to provide protection against falling objects. This also applies to work that only takes a short period of time.

Safety nets (mesh size ≤ 2 cm) and platform planking are considered to be suitable means and are to be installed very close to the structure (distance ≤ 5 cm).

Secure all bolts with cotter pins and all screws with nuts.

Secure tools and material to prevent them from falling down. Remove concrete residue and other dirt as soon as possible, at the latest before the next climbing cycle. The platforms are to be kept clean at all times.

Operational working areas at great heights are to be secured by means of appropriate structural measures to prevent objects from falling down.

Components that are likely to become unstable

Components

Secure components that are likely to become unstable with suitable means, e.g. using push-pull props, or leave them attached to the crane until the tipping hazard has been eliminated.

Draw attention to and clearly mark any danger zones.

If necessary, cordon off the danger zones with suitable means. Check that safety signs and barriers are in place before commencing work.

Climbing procedure

Take into consideration the permissible wind speed limit for the climbing procedure.

Site personnel, construction materials or tools must not be transported with the crane during relocation operations. Exceptions to this can be determined through the operational working and assembly instructions on the basis of a corresponding risk analysis.

The climbing procedure must be monitored by a competent and qualified person.

During the climbing procedure, clamping and crushing hazards are brought about by moving components.

The individuals carrying out the climbing procedure must be fully informed about all possible hazards.

All persons who are not required to carry out the climbing procedure must leave the danger zones.

When climbing with the hydraulic climbing device, specifications regarding the arrangement of the hydraulic hoses must be observed. If the standard arrangement is not possible, an authorised person must determine a safe and secure alternative.

As a result of the moving procedure, open edges are formed between the platforms as well as at building openings. If work is carried out in this area, site personnel must be protected to prevent them from falling (e.g. PPE).

Secure all resulting shearing edges by means of covers. Cordon off danger zones during the climbing procedure.

In case of a malfunction, lower the platform to the next possible position. Personnel are to leave the climbing unit in a safe and secure manner and a person who is authorised to give instructions is to be notified immediately.

The climbing system cannot be mounted for the next concreting section until the required concrete strength has been achieved.

Maintenance and repairs

The components of the climbing system are to be inspected before every use to ensure that they are in flawless condition.

Only flawless materials may be used. Have the climbing units checked monthly for signs of damage by competent persons who are authorised to give instructions.

Remove concrete residue and dirt immediately after concreting.

Immediately remove any dirt that impairs functionality. Remove and replace damaged components.

In case of overload or damage, stop work on and under the platforms, determine the cause, set down and replace damaged components.

If the maximum permissible wind speed has been exceeded, temperatures are outside the scope of application or after any extraordinary event has taken place, the functionality and load-bearing capacity of all safety components as well as the supporting structure are to be checked.

Safety components:

- A visual inspection is to be carried out by authorised personnel before each climbing procedure.
- Before each climbing procedure or each assembly procedure, a functionality check is carried out by qualified personnel.
- If parts need to be replaced, only PERI original components may be used.
- Repairs are to be carried out by qualified PERI personnel only.
- In the case of overloading or recurrent damage, stop work operations on and under the platforms, determine the cause and rectify.

Supporting structure:

- A visual inspection is to be carried out by authorised personnel before initial use.
- Only PERI original components are to be used for repairs or replacement.
- In the case of overloading or recurrent damage, stop work operations on and under the platforms, determine the cause and rectify.

Other components:

- Repairs are carried out by authorised personnel and the person authorised to give instructions is to be informed.
- In the event of recurring damage, determine the cause and remedy it.

Hydraulic components

Visual inspections are to be carried out by authorised personnel at regular intervals.

Qualified personnel are to carry out a functionality check before every working cycle or before assembly takes place.

If any defects are discovered, repairs are only allowed to be carried out by qualified personnel.

Hydraulic hoses have an expiry date. Observe the manufacturer-specific information.

Do not suspend any objects from the hydraulic hoses.

Arrange and securely fasten the hydraulic hoses in such a way that they do not create any tripping hazard and cannot be pinched, kinked, pulled or shorn off.

Observe minimum bending radii.

Observe the manufacturer-specific information regarding inspection and maintenance of the hydraulic unit.

For correct use and disposal of the hydraulic oil, observe the manufacturer-specific instructions.

Thicken spilled hydraulic oil immediately with oil binder and mop it up.



Wear safety goggles and suitable protective gloves when working on the hydraulic system.

Electrical components



Danger

High electric voltage at the hydraulic unit!

Death or serious injury can result from an electric shock.

⇒ Connection only by qualified personnel.

⇒ Only qualified personnel may carry out work and repairs on the electrical components of the systems.

⇒ Only approved, undamaged and tested connecting cables should be used.

Compare the required type of current and voltage with the information on the type plate.

Do not suspend any objects from the electrical lines.

Arrange and securely fasten the electrical lines in such a way that they do not create any tripping hazard and cannot be pinched, kinked, pulled or shorn off. Observe minimum bending radii.

Store and transport components in such a way that no unintentional change in their position is possible. Detach lifting accessories and lifting gear from the lowered components only if they are in a stable position and no unintentional change is possible.

Do not drop the components.

Use PERI lifting accessories and lifting gear and only those load-bearing points provided on the component.

During the relocation procedure

- ensure that components are picked up and set down in such a way that unintentional falling over, falling apart, sliding, falling down or rolling is avoided.
- no one is allowed to remain under the suspended load.

The access areas on the construction site must be free of obstacles and tripping hazards, and must also be slip-resistant.

For transportation, the substrate must have sufficient load-bearing capacity.

Use original PERI storage and transport systems, e.g. crate pallets, pallets or stacking devices.

Component overview

Pos. no.	Component name	Article no.
1	Upper Climbing Rail RCS	
1.1	Climbing Rail RCS 348	109470
2	Lower Climbing Rail RCS	
2.1	Climbing Rail RCS 498	109471
3	Spacer M20-82	110022
4	Spacer M24-82	110023
6	Climbing Rail Extension RCS 100	109791
7	Climbing Rail Extension RCS 125	113745
8	Climbing Rail Joint RCS	110569
9	Lifting Eye BR-2 2.5 t	127834
10	Climbing Beam 9 t	127320
11	Diagonal strut l = 2121	110012
15	Filler pin Ø 21 x 120	104031
16	Cotter pin 4/1	018060
20	Work platform	
21	Crossbeam Unit RCS 220 VARIO	118094
22	Crossbeam Head RCS/VARIO	132800
24	Carriage RCS	109968
25	Steel Waler Universal SRU L = 2.72	103929
26	Waler Fixation U100-U120	110059
27	Height Adjustment Unit SRU, outer	110400
28	Heavy Duty Spindle SLS 200/300	101778
32	Waler	
33	Finishing platform	
34	Finishing platform girder	109722
35	Strongback Adapter RCS/SRU	115325
36	Concreting platform	
37	Platform Beam RCS/SRU 113	114301
39	Intermediate formwork platform	
40	VARIO formwork	
41	TRIO element	
42	Leading tie	
42.1	Positioning Screw M30	029450
42.2	Anchor Positioning Stud M30	026450
42.3	Anchor Positioning Plate M30	029380
47	Anchoring	
47.1	Screw-On Cone M30/DW 26	057257
47.2	Threaded Anchor Plate DW 20	030860
47.5	Climbing Cone-2 M30/DW 20	031220
47.6	Tie Rod DW 20, special length	030700
47.7	Threaded Anchor Plate DW 26	030870
47.9	Cone DR 22	065033
50	Climbing Shoe RCS	109468
51	Wall Shoe RCS	109503

Pos. no.	Component name	Article no.
53	Wall Shoe RCS, rotatable	110667
54	Eccentric Lever RCS	110950
60	Climbing Device RCS 50	109765
61	Hydraulic twin hoses RCS 10 m	110069
62	Hydraulic twin hoses RCS 20 m	110070
63	Hydraulic Unit RCS 4 x 190 bar	109766
64	Adapter Cable RCS	110280
65	Coupling Socket RCS, black	110279
66	Hatch RCS 55 x 60-2, foldable	126431
67	Ladder 180/6	051410
68	Ladder 220/6	051420
69	Access ladder 180/2 complete	103724
70	Ladder Base 30, adjustable	109105
71	Ladder hook	103718
72	Ladder Cage 75	104132
73	Ladder Cage 150	051450
75	Formwork Girder GT 24, e.g. 450	075450
76	Planking	
77	Toe board	
78	Squared timber angle connector 90°	123478
79	Guardrail Post RCS 226	109720
80	Guardrail Post RCS/SRU 184	114328
81	Guardrail Post 384 RCS	109721
82	Guardrail boards	
84	L-bracket	110289
87	Scaffolding tube bracing	
88	Steel scaffolding tube Ø 48.3 x 3.2	026413
89	Clamp A64 DIN 3570	110296
90	Guardrail Post SCS 150	118579
91	Scaffold Tube Holder LPS/RCS D = 48	125856
93	Guardrail Post Connector CB	051160
94	Guardrail post holder multi	126088
95	Standard Coupler RA 48/48	017020
96	Screw-on coupling-2 HT B D48-M20	131404
97	Swivel Coupling AF 48/48	017010
98	Squared timber 6/6	
99	Deck covering	
101	Bolt ISO 4017 M12 x 40-8.8	710224
102	Bolt ISO 4017 M12 x 140-8.8	110598
106	Bolt ISO 4014-M20 x 120-8.8	104477
107	Bolt ISO 4014-M20 x 150-8.8	711084
108	Bolt ISO 4014-M24 x 130-8.8	109612
109	F.H. Bolt DIN 603 M8 x 45 MU	710295
110	F.H. Bolt DIN 603 M8 x 100 MU	710240

Pos. no.	Component name	Article no.
111	FI-Rd Bolt M08X070-DIN603-8.8VZ	126228
111.1	Self-cleaning nut M8 VZ	024090
112	Lock screw M08X125-8.8-VZ-MU	024390
114	Lock screw M08X125-8.8-VZ-MU	131375
115	Nut ISO 7040-M20-8	781053
118	Nut ISO 7040 M12-8	710381
120	Washer ISO 7093 200 HV, A8	710342
121	Washer ISO 7089 200 HV, A8	780354
122	Washer ISO 7094-12-100HV	113348
125	Wood screw 6x80 SK-TX30 HPI	024690
126	Wood screw 6x60 SK-TX30 HPI	024470
127	Wood screw 6x40 SK-TX30 HPI	024540
129	Wood screw 5x20 SK-TX20 HSX	111437
132	Wood screw 6x100 SK-TX30 HSX	024950
135	Hex wood screw 6 X 20 DIN 571	029440
137	Hex wood screw 8 X 60 DIN 571	024270
138	Hex wood screw 8 X 80 DIN 571	024260
139	Wingnut Pivot Plate DW 15	030370
140	Formwork Waler 150 CB	127633
141	Hook Tie DW 15/400	023650
142	Clamp Adapter MX/TR-SRU	127659
143	Wire nail 3 x 80	710312

Tool name
Cordless screwdriver
TORX 25/30/35 screw bits
Ring wrench, open-end wrench, socket wrench AF 13/17/19/30/36/46
Wood drill Ø 5/8
Torque wrench
Hammer
Round slings
4-sling lifting gear

Abbreviations used in these Instructions for Assembly and Use:

- a Tie spacing for concrete joints
- b_n Width of n-th designated section
- C Climbing rail spacing
- d_n Thickness of n-th designated section
- G Weight force
- V Vertical force
- V_{AY} Tie shear force
- N_A Tie tensile force
- H Height
- h_n Height of n-th designated section
- h_b Storey height
- H_x Horizontal force
- L Length
- L_n Length of the n-th designated section
- q Wind load
- V Vertical force
- v Speed
- W Wind pressure

Tightening torques

Unless otherwise indicated, PERI recommends the following guide values for screw connections as "hand-tightened" tightening torques $M_{A, \text{hand-tightened}}$. These guide values are based on EN 15048 with minimum Safety Factor 3 against breakage.

Quality class	Quality 4.6		Quality 8.8 and 10.9
	Lightly oiled	MoS2	undefined
Screw M8	8 Nm	6.6 Nm	8 Nm
Screw M10	16 Nm	13.0 Nm	16 Nm
Screw M12	30 Nm	23.0 Nm	30 Nm
Screw M16	65 Nm	54.0 Nm	65 Nm
Screw M20	100 Nm		100 Nm
Screw M24	150 Nm		150 Nm
Screw M30	260 Nm		260 Nm
Screw M36	350 Nm		350 Nm

Tightening torques have been determined for the following components:

Scaffolding tube coupling	50 Nm
Clamping plate for the slab tie gauge	120 Nm

Climbing unit

The construction of the climbing scaffold varies depending on the storey height, the formwork used and the type of lateral protection.

In all versions, the climbing rails (**1 + 2**) are supported by climbing shoes (**50**) and wall shoes (**51**) which are mounted on parts of the structure that have already been assembled.

The climbing rails are usually split.

The crossbeams (**21**) for the work platform with carriage and strongback (**25**) for the formwork system are mounted on the upper climbing rails (**1**).

The finishing platform (**33**) with finishing platform girder (**34**) and guardrail post (**88**) is mounted on the lower climbing rail (**2**).

The lateral protection can take the form of a closed enclosure consisting of scaffolding tubes or guardrail boards.

Variant 1:

Use with TRIO formwork (**41**) and scaffolding tubes as lateral protection
Storey height (h_B) 3.00 m to 3.60 m (Fig. A1.01)

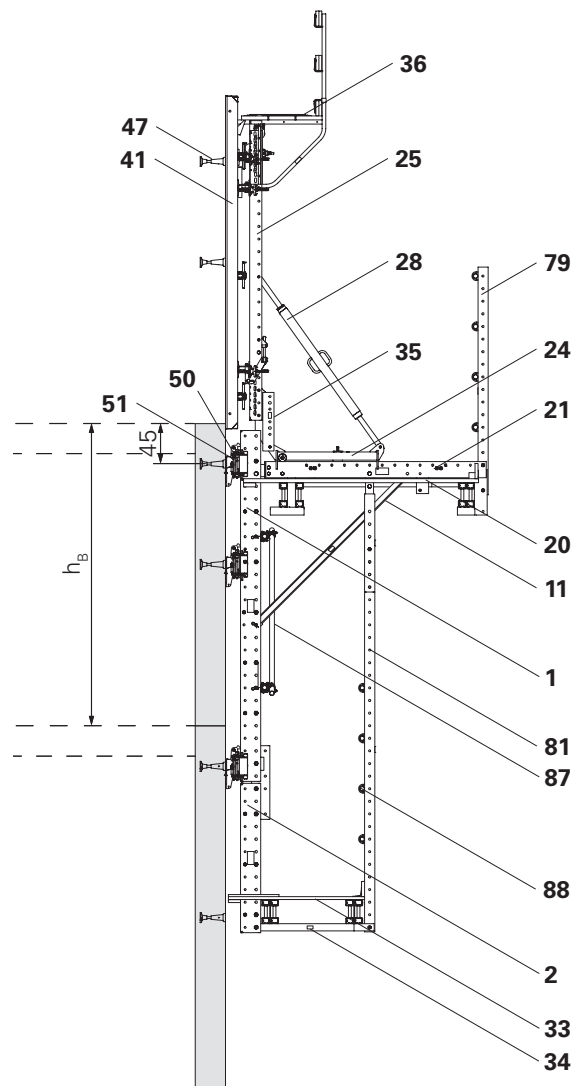

Fig. A1.01

Variante 2:

Use with VARIO formwork and scaffolding tubes as lateral protection
 h_B 3.60 m to 4.00 m.
 (Fig. A1.02)

Components

- 1 Upper Climbing Rail RCS
- 2 Lower Climbing Rail RCS
- 11 Diagonal strut I = 2121
- 20 Work platform
- 21 Crossbeam Unit RCS 220 VARIO
- 24 Carriage RCS
- 25 Strongback RCS (Steel Waler Universal SRU L = 2.72)
- 28 Formwork spindle (heavy duty spindle e.g. SLS 200/300)
- 33 Finishing platform
- 34 Finishing platform girder
- 35 Strongback Adapter RCS/SRU
- 36 Concreting platform
- 40 VARIO formwork
- 41 TRIO formwork
- 47 Anchoring for next section
- 50 Climbing Shoe RCS
- 51 Wall Shoe RCS
- 79 Guardrail Post U100 225 RCS
- 81 Guardrail Post U100 384 RCS
- 87 Scaffolding tube bracing
- 88 Steel scaffolding tube \varnothing 48.3 x 3.2

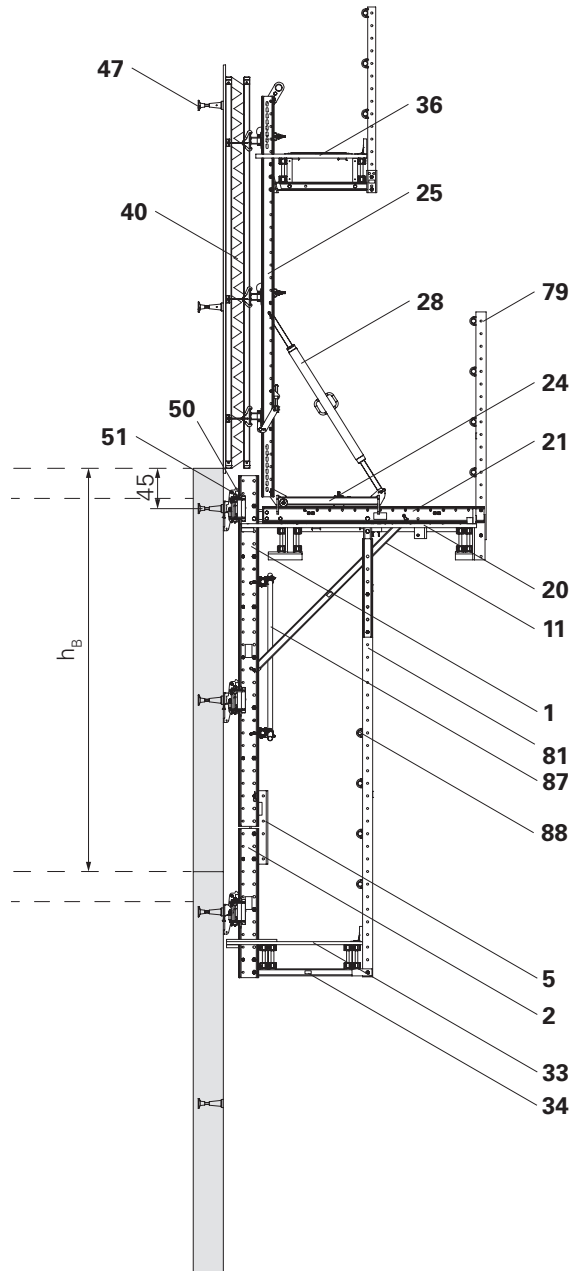

Fig. A1.02

Variante 3:

Use with VARIO formwork and scaffolding tubes as lateral protection
 h_B 4.00 m to 4.50 m.
 (Fig. A1.03)

Components

- 1 Upper Climbing Rail RCS
- 2 Lower Climbing Rail RCS
- 5 Climbing Rail Connector RCS 73
- 11 Diagonal strut I = 2121
- 20 Work platform
- 21 Crossbeam Unit RCS 220 VARIO
- 24 Carriage RCS
- 25 Strongback RCS (Steel Water Universal SRU)
- 28 Formwork spindle (heavy duty spindle e.g. SLS 200/300)
- 33 Finishing platform
- 34 Finishing platform girder
- 36 Concreting platform
- 40 VARIO formwork
- 47 Anchoring
- 50 Climbing Shoe RCS
- 51 Wall Shoe RCS
- 79 Guardrail Post U100 225 RCS
- 81 Guardrail Post U100 384 RCS
- 82 Guardrail boards
- 87 Scaffolding tube bracing

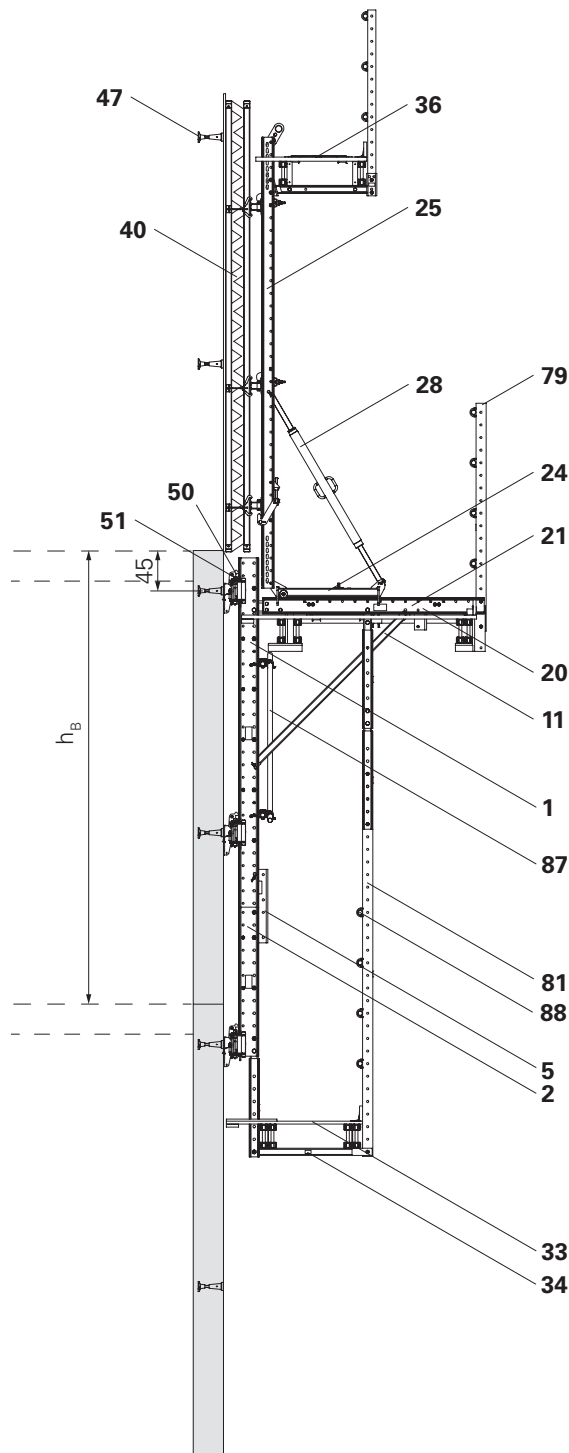

Fig. A1.03

General information

This section provides basic information about the climbing device and hydraulic unit. Further information is provided in the following sections, as well as in the separate assembly instructions for the RCS Climbing Device and hydraulics.

Climbing Device RCS 50

The Climbing Device RCS 50 is used for gradually climbing the climbing formwork.

Once the climbing procedure is completed, the climbing formwork must be placed on the climbing pawls of the climbing shoes ensuring that the load is fully supported. The climbing device must be free of load.

(Fig. A2.01 + A2.02)

Main components

- 60** Climbing Device RCS 50 ^{1*}
- 60.1** Piston with claw and roller
- 60.2** Cylinder base
- 60.3** Return from rod side with Quick-Coupler Nipple RCS for the left and right, with protective cap
- 60.4** Inflow to the piston base with Quick Coupler Bushing RCS left and right, with protective cap
- 60.5** Cylinder repositioning (spring-loaded)
- 60.6** Locking lever (spring-loaded)

The quick couplers on the climbing device and hydraulic unit are interchangeable.

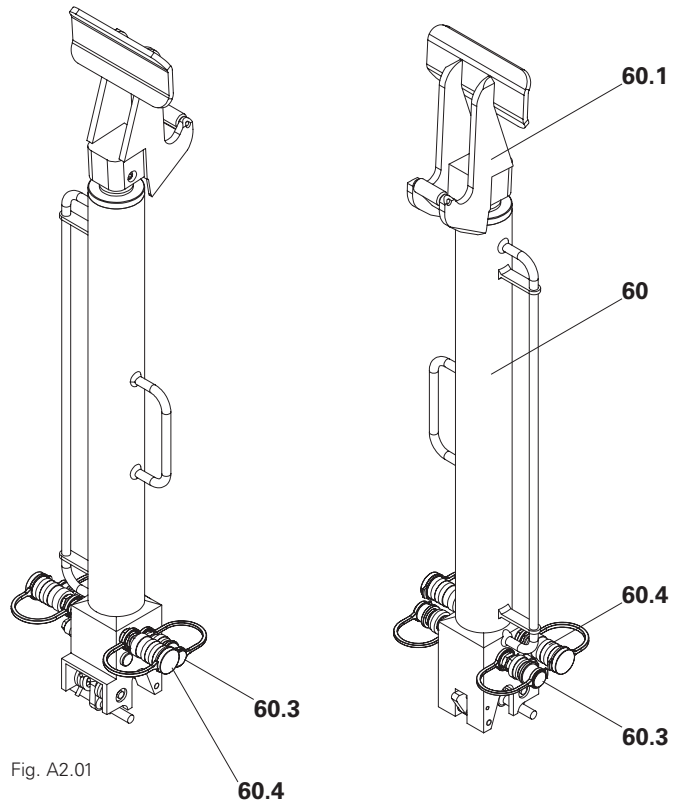

Fig. A2.01

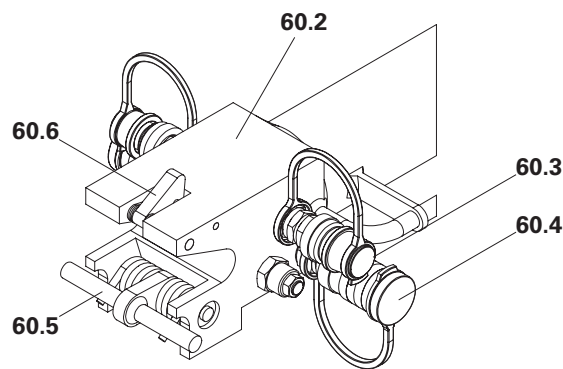

Fig. A2.02



To prevent the quick-couplers from colliding with the platforms or other parts of the climbing unit when climbing, it is possible to equip the climbing devices with angle pieces.

→ Contact PERI.

^{1*} Safety components.

Hydraulic unit

Hydraulic Unit RCS 4 x 190 bar,
380 – 460 V (63) for 4 climbing
devices RCS 50^{1*}.
(Fig. A2.03 + A2.03a)

Main components

- 63** Hydraulic Unit RCS
4 x 190 bar, 380 – 460 V
- 63.1** Control lever
- 63.2** Switch unit
- 63.3** Power socket with phase inverter
- 63.4** Hydraulic oil tank
- 63.5** Filler tube
- 63.6** Oil level indicator, thermometer
- 63.7** Return filter
- 63.8** Return from the rod side of the
cylinder with Quick Coupler
Bushing RCS
- 63.9** Inflow to piston bottom side of
cylinder with Quick-Coupler
Nipple RCS
- 63.10** Rotary field control lamp

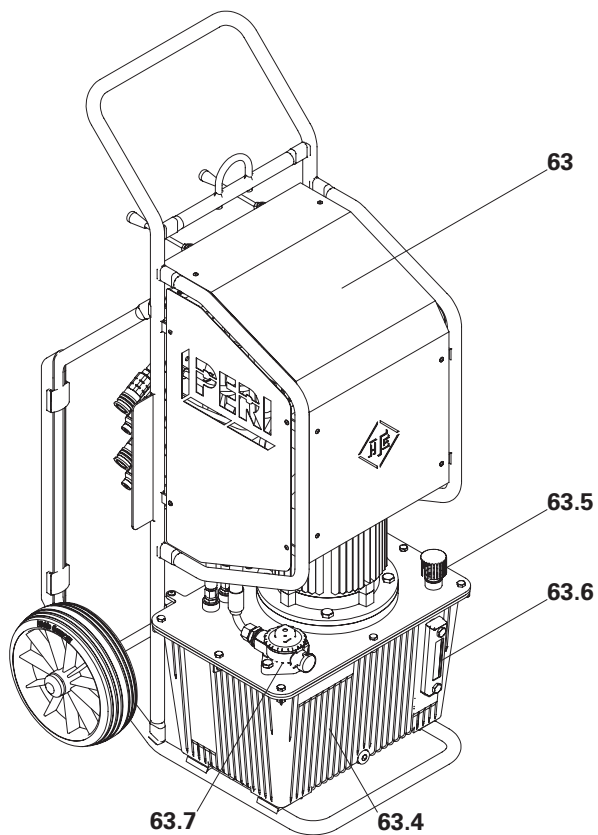

Fig. A2.03

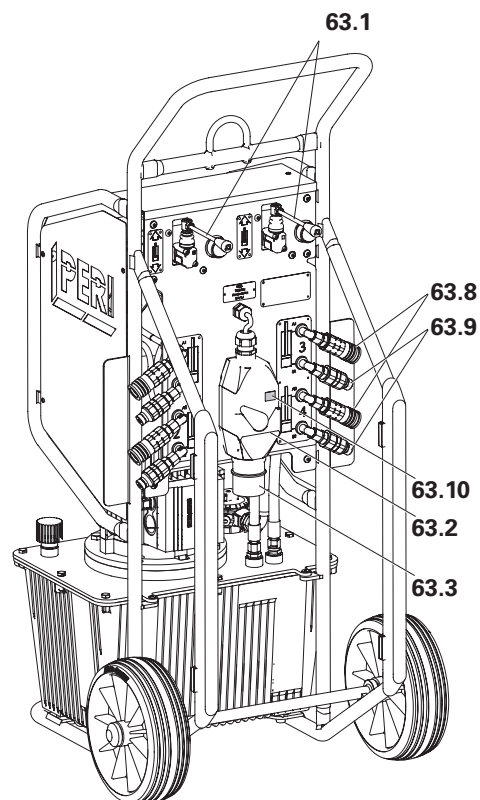

Fig. A2.03a

^{1*} Safety components.

Accessories

(Fig. A2.04 + A2.05)

- 64** Adapter Cable RCS for supply line with CEE socket
- 65** Coupling Socket RCS, black for fitting an adapter cable

Hydraulic hose

The hydraulic twin hose is available in Lengths L = 10 m and 20 m available. (Fig. A2.06 + A2.07)

- 61** Hydraulic Twin Hose RCS 10 m
- 62** Hydraulic Twin Hose RCS 20 m
- 61.3** Quick Coupler Bushing RCS
- 61.4** Quick-Coupler Nipple RCS



During transport, join the two coupler ends together to protect the hoses. (Fig. A2.08)

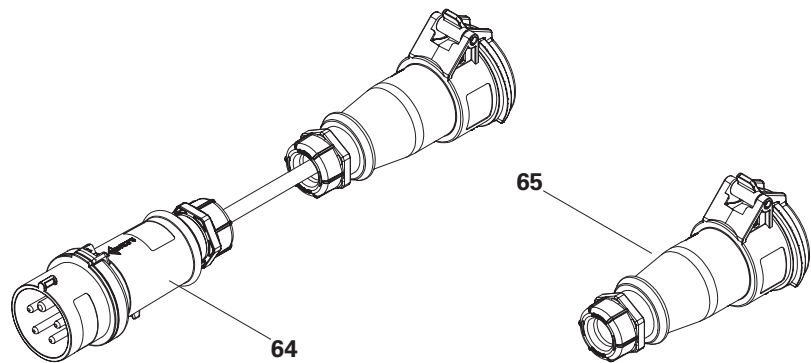

Fig. A2.04

Fig. A2.05

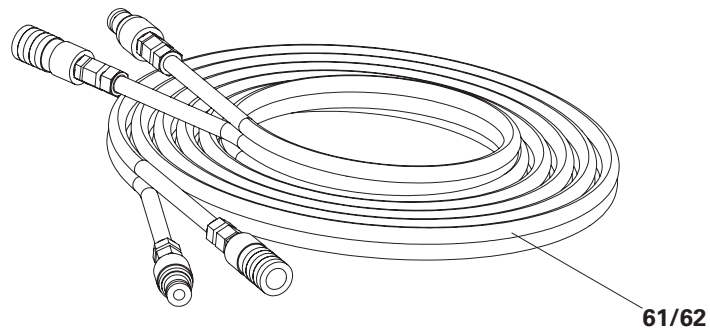

Fig. A2.06

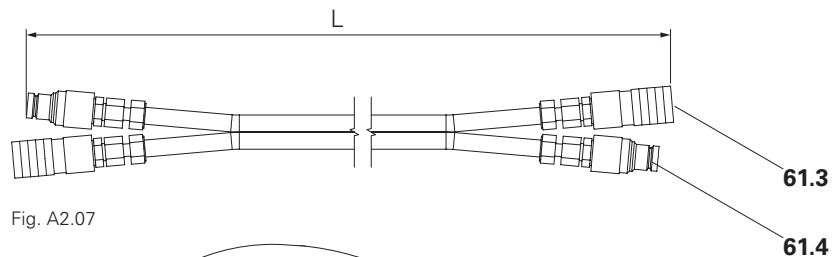

Fig. A2.07

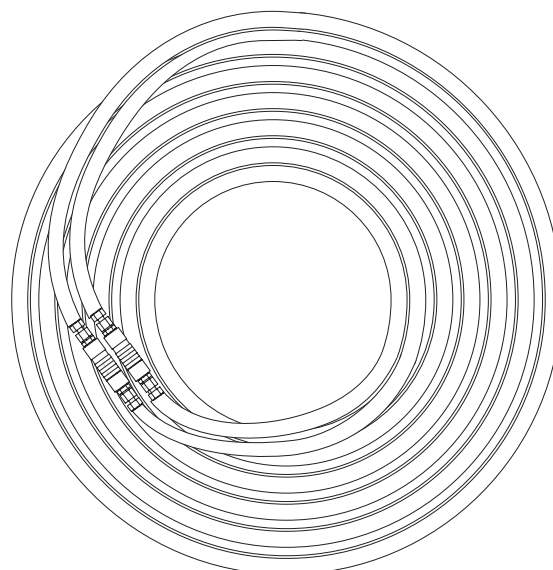

Fig. A2.08

Operating states and loads

Operating status: Working

All work carried out on the climbing formwork and its work platforms:

- Cleaning the formwork, reinforcing the wall, closing the formwork, concreting and striking, inspection and maintenance.
→ Platforms must be freely accessible for the required work to be carried out.
- Moving the formwork backwards and forwards on the carriage.
- Max. wind speed 72 km/h (dynamic wind pressure $q = 0.25 \text{ kN/m}^2$).
- Loads are evenly distributed. Unilateral loads on cantilevered platform areas are only permitted with suitable lift locks on the reciprocal console bracket.

Operating status: Climbing

Moving the climbing unit by crane or by means of the hydraulic climbing device

- Move the formwork backwards on the carriage.
- Remove non-planned loads from the platforms.
- Climbing by crane: **Walking on the platforms while climbing is prohibited.**
- Self-climbing: The personnel required for climbing usually stand on the adjacent platforms. When climbing the final platforms of a cycle or when manually intervening in the self-climbing process, it is necessary to step onto the platform being climbed.
- Max. wind speed 64 km/h (dynamic wind pressure $q = 0.20 \text{ kN/m}^2$).
- The climbing position must be verified statically, as this can be decisive.

Non-operational

During longer work breaks, overnight, storm warnings, measured wind speeds above 72 km/h:

- Move the formwork into the concreting position on the carriage.
- Remove materials and equipment from the work platforms.

Sudden storm

- In the event of sudden storms or lightning hazards, only put the safety measures in place if this does not pose a danger to personnel. Otherwise leave the climbing formwork immediately.
- Accessing the platforms during storm conditions is prohibited.
- Material and equipment can be left on the work platform.
- Clear areas below.

Storm warning

- The assumed wind speed (dynamic wind pressure) during storm conditions is calculated based on the respective application height, wind zone and terrain category according to DIN EN 1991-1-4 or EC 1.
- If given limits are exceeded, a visual inspection of all load-bearing components and a functional check of all safety components are necessary for further use.
- If a storm warning has higher wind speeds than originally stated, the site management must be informed. Remove any enclosure tarpaulins that may be attached.
- On the instructions of authorised site personnel, the climbing formwork can be climbed down to the previous storey. For this, additional instructions are required. Remove materials and equipment from the platforms.

Overview of live loads



Verify the supporting structure for these loads and conditions by means of a static calculation based on PERI product information.

Platform	State				
	Reinforcing	Concreting	Climbing	Non-operational	Storm
Concreting platform level +1	75 kg/m ²	150 kg/m ²	–	–	–
Intermediate platform on formwork	–	–	–	–	–
Work platform level 0	200 /300 kg/m ² *	150 kg/m ²	75 kg/m ²	200 kg/m ²	–
Finishing platform level -1	–	–	75 kg/m ²	–	–

* The maximum live load of the work platform can be designed for 200 kg/m² or 300 kg/m², depending on requirements.

The areas projecting over the corner of the building on corner platforms must not be loaded with more than 150 kg/m² during work operations. Storage of materials in these areas is not permitted.

Each platform is rated for at least 150 kg/m² live load.

In the case of deviating working conditions and distributions, the sum of the live loads must be adhered to.

Overview of wind loads

	State			
	Working	Climbing	Non-operational	Storm*
Wind speed	72 km/h	64 km/h	>72 – 102/136 km/h	136 – 188 km/h
Dynamic wind pressure	0.25 kN/m ²	0.2 kN/m ²	>0.25 – 0.5/0.9 kN/m ²	0.9 – 1.7 kN/m ²
Position of the carriage	Any	Retracted	Formwork closed	Formwork closed

* The wind speed (wind pressure) to be assumed during a storm is calculated according to DIN EN 1991-1-4 or EC 1 depending on the altitude, wind zone and terrain category. Different aerodynamic coefficients, which are determined by a wind assessment, are applicable for the position in the ground plan (corner, transition or central control range).

The wind loads are to be assumed in accordance with the applicable national standard.

This structural design information takes into consideration loads in accordance with DIN EN 1991-1-4, taking into consideration an available wind report.

Sequence of operation

In principle, all variants can be climbed with a crane or hydraulic climbing device.

However, when climbing with a crane, the weight of the units may be limited by the crane's load-bearing capacity.

When climbing with a hydraulic climbing device, the weight is, in theory, limited to 9 t.

Hydraulic climbing is possible after the 1st work cycle.

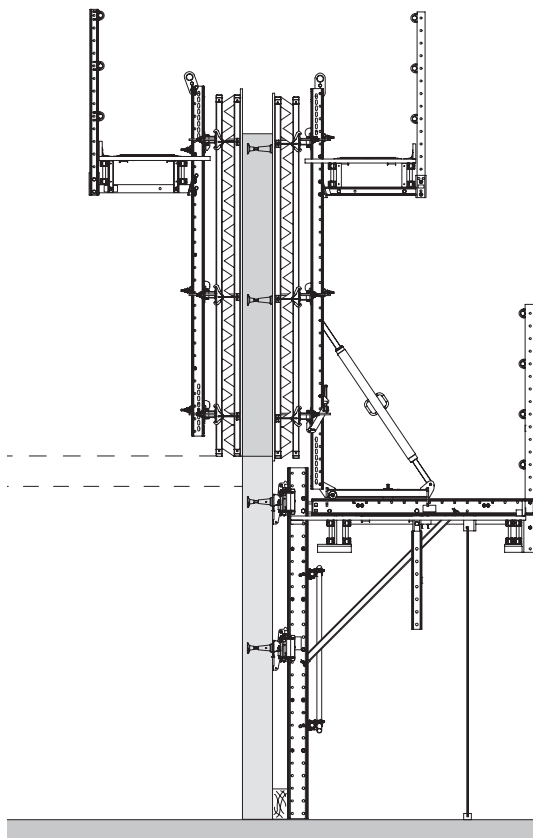

Fig. A4.01

1st work cycle

Attach the work platform to the 1st concreting section, brace it and install the formwork.

Reinforce, and concrete the 2nd section.

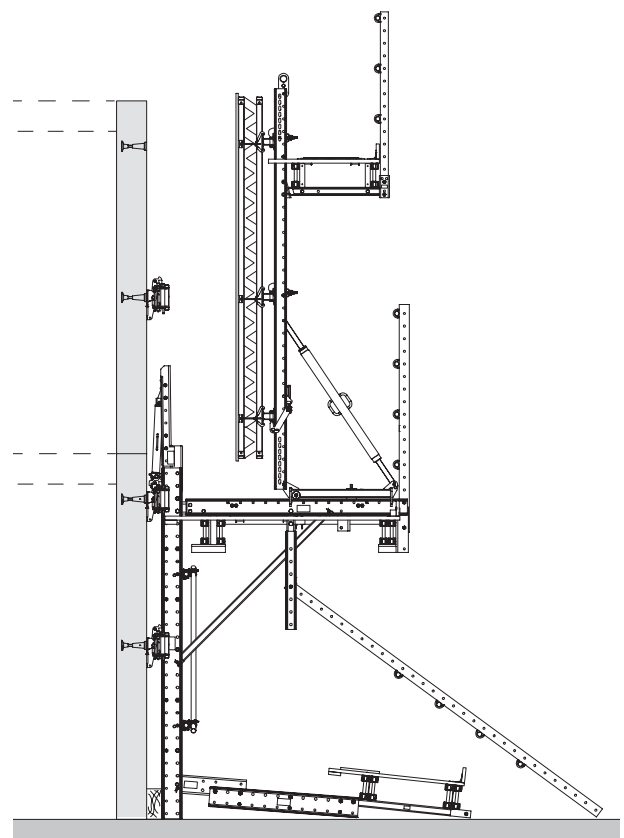

Fig. A4.02

2nd work cycle

Fit climbing shoes, climbing rail extensions and fit climbing device.

Attach the finishing platform.

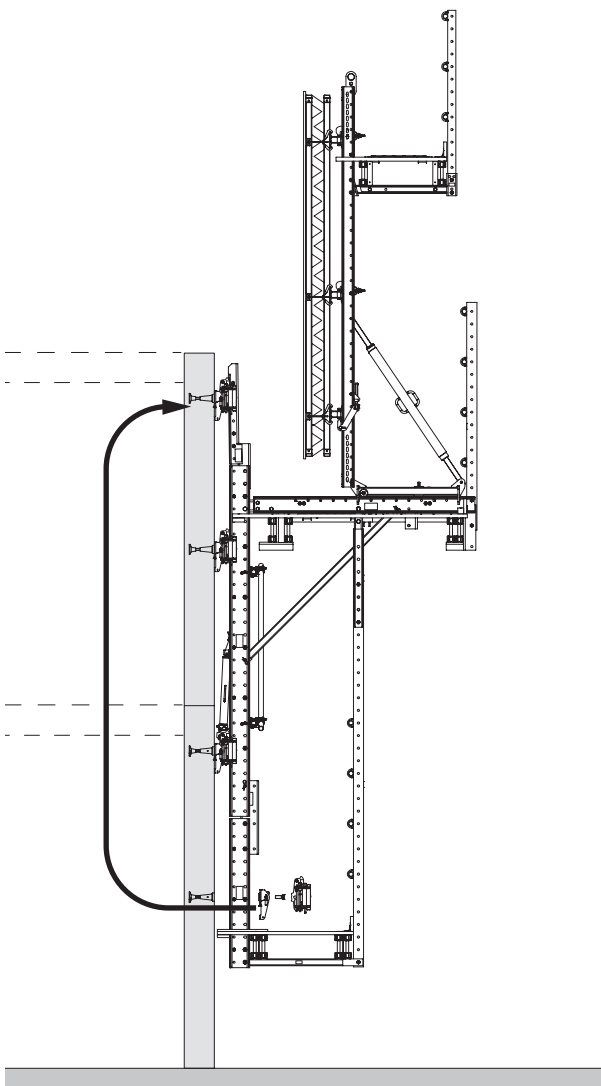

Fig. A4.03

3rd work cycle

Climb to the 2nd concreting section. The climbing rail extension leads into the climbing shoe.
 Complete the finishing platform attachment process.
 Remove the lower anchoring.

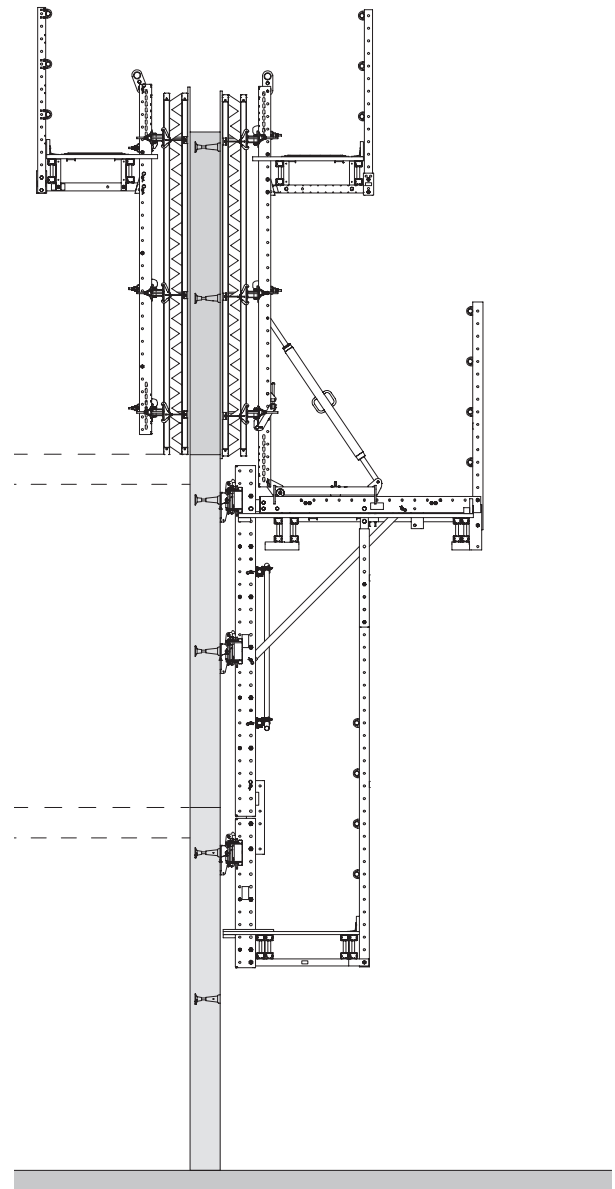

Fig. A4.04

4th work cycle

Dismantle the climbing rail extension.
 Fit the leading tie, close the formwork, reinforce and pour the concrete.

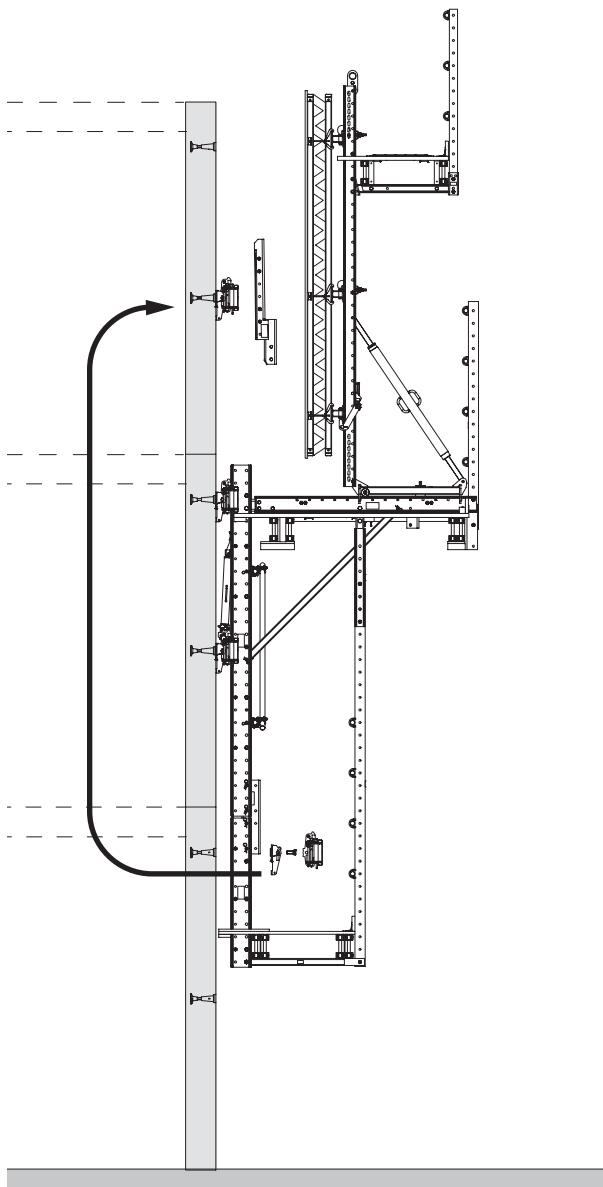

Fig. A4.05

5th work cycle

Remove the formwork, remove the lower wall shoe and climbing shoe, and fit them in the next concreting section. Fit the climbing rail extension and climbing device. Self-climb the climbing formwork.

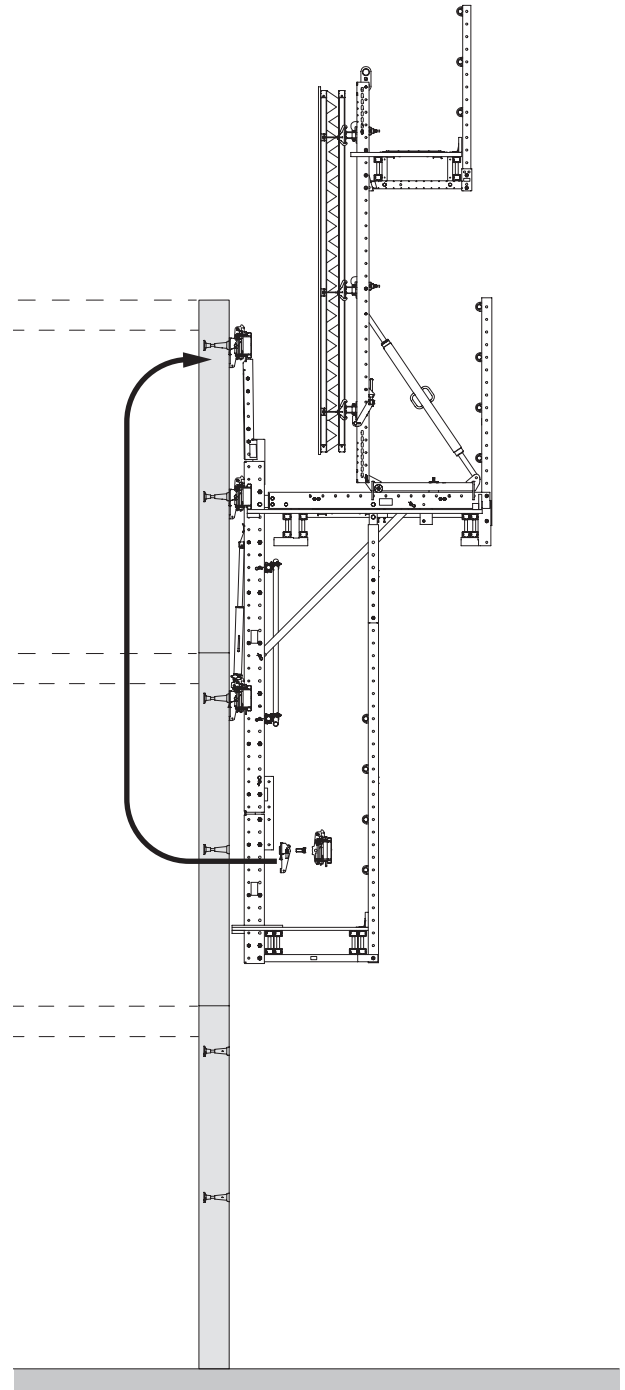

Fig. A4.06

6th work cycle

Interrupt the climbing process and remove and re-fit another climbing shoe.

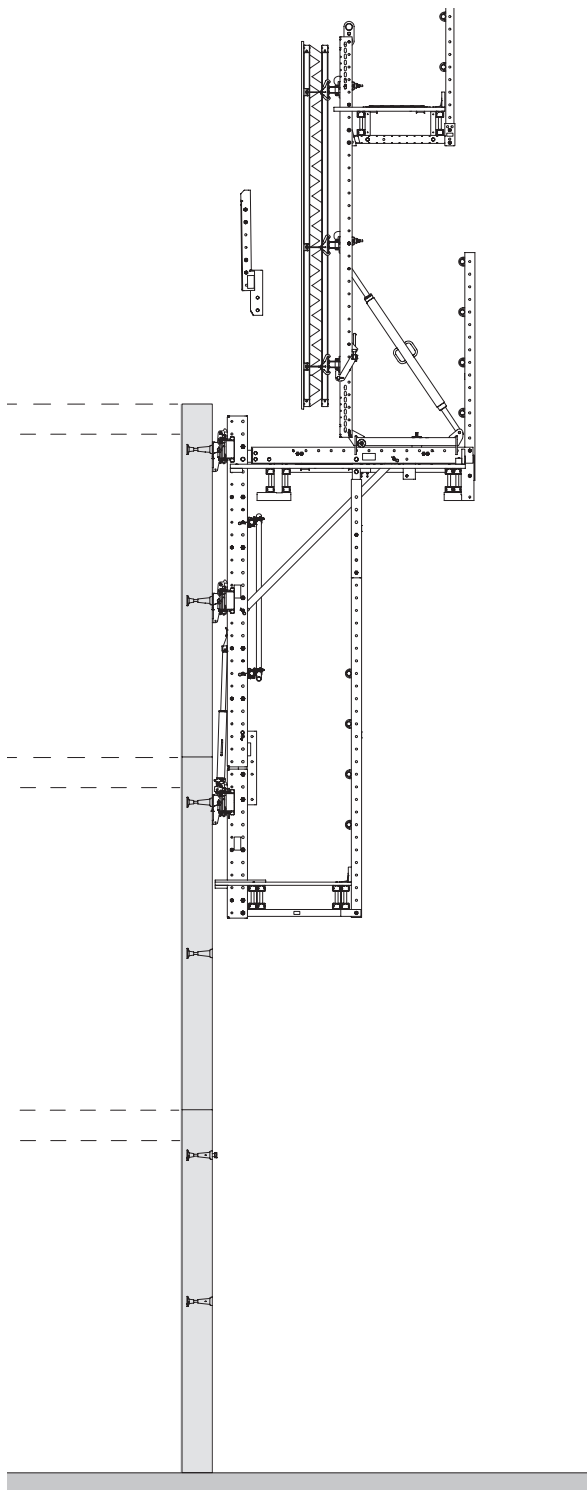

Fig. A4.07

7th work cycle

Continue climbing until you reach the end position.
Remove the climbing rail extension in the end position.



For each additional floor, repeat the procedure starting from work cycle 4.

System dimensions

Climbing rails

Depending on the storey height h_B , combine the climbing rails in such a way that at least 2 climbing shoes are guiding the climbing rail at all times. Ensure that the vertical distance between the climbing shoes is even.

Total length

Upper and lower climbing rail:
 $3.48 \text{ m} + 1.48 \text{ m} = 4.96 \text{ m}$,
 with climbing rail extension:
 $4.96 \text{ m} + 1.00 \text{ m} = 5.96 \text{ m}$.

Smallest permissible climbing shoe spacing 1.50 m. (h_1)

At the climbing shoe supporting the climbing device, the distance to the climbing shoe above must be at least 2.00 m (h_2).

If this distance has to be undercut, for example due to low storey heights, at least 3 climbing shoes must be guiding the climbing rail at all times. The lowest climbing shoe may only be removed when the upper climbing rail extension is guided entirely by the next climbing shoe.

If necessary, mount the finishing platform lower down on a climbing rail extension.

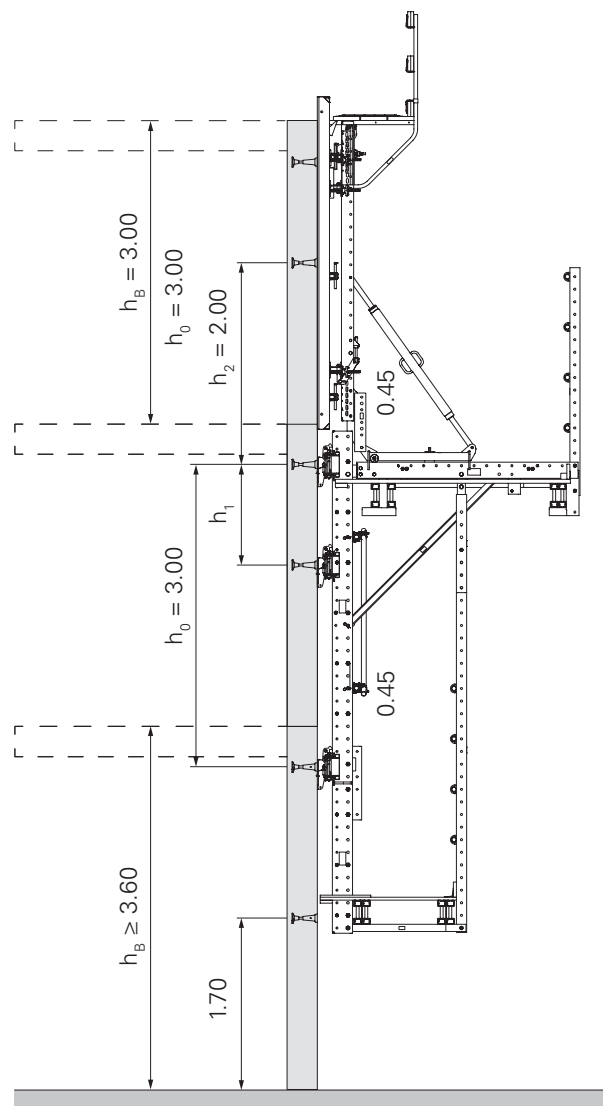

Fig. B1.01a

Typical arrangement for storey heights
 h_B 3.00 m to 3.60 m.

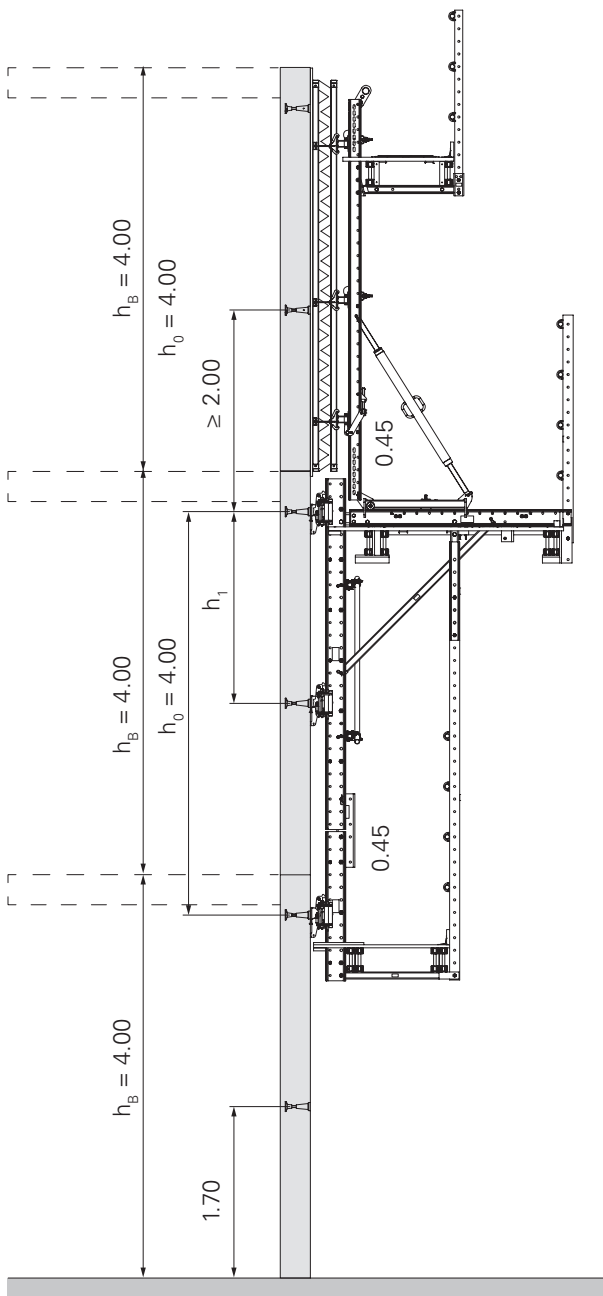

Fig. B1.01b

Typical arrangement for storey heights
 h_b 3.60 m to 4.00 m.

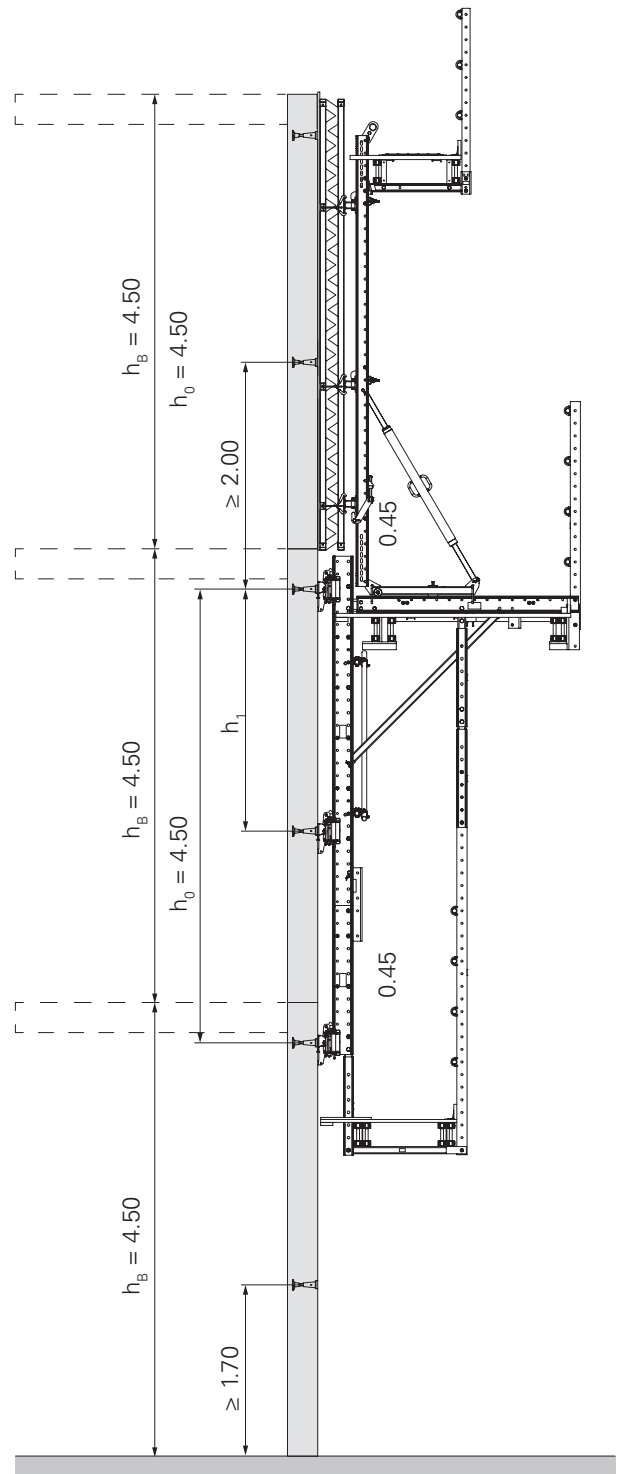

Fig. B1.01c

Typical arrangement for storey heights
 h_b 4.00 m to 4.50 m.

Framework assembly

Climbing rail spacing

Determine and verify the spacing of the climbing rails for the project at hand.

Starter height and anchoring distance

Tie spacing (a) 45 cm.

Length of upper climbing rail 3.48 m.

Starter height at least 3.60 m.



The specified dimensions are determined by the:

- Requirements for proper assembly and alignment of the formwork.
- Functionality of the first section to be self-climbed.
- Attachment of the pre-assembled finishing platform.

Support the climbing rail at the lower end with a Climbing Rail Joint RCS (8) or squared timber (thickness 15 cm) as a pressure point against the wall.

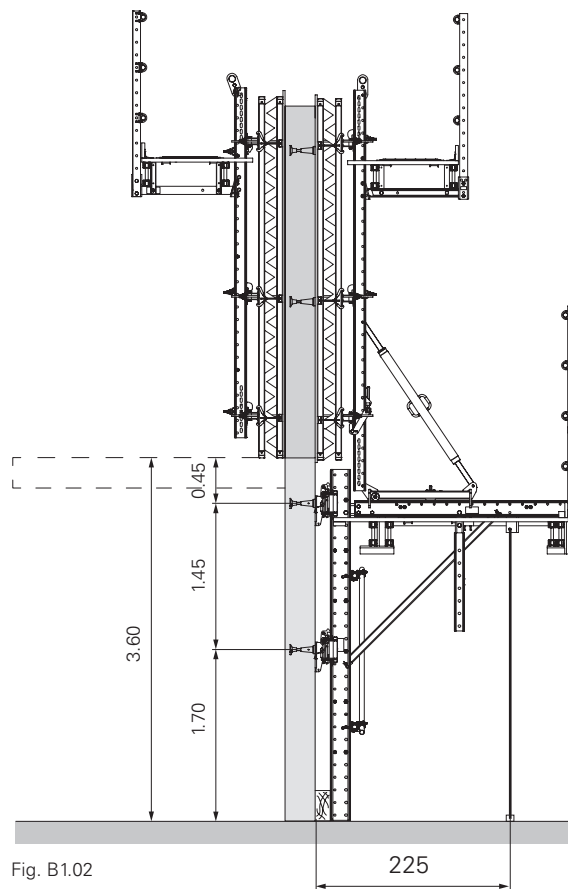

Fig. B1.02

Additional spacers

Spacers are mounted at a distance of 50 cm on the climbing rails.

Additional spacers

M20-82 (3) can be installed on the climbing rail (2) as climbing bolts. This allows the height of the climbing formwork and work platforms to be adjusted in increments of 12.5 cm.

(Fig. B1.03 + B1.04)

Spacers are used to support the climbing units on climbing shoes during working operations.



PERI recommends mounting an additional spacer M20-82 for the load-bearing slab shoe for standard storey heights that are multiples of 50 cm. This ensures a definite bearing on the planned slab shoe without having to deactivate the other slab shoes.

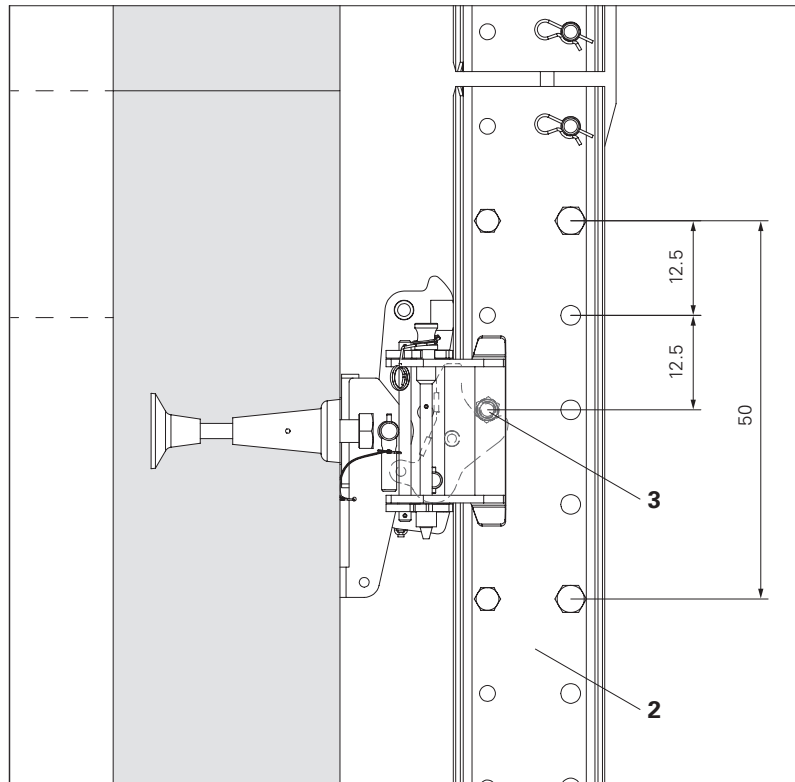

Fig. B1.03

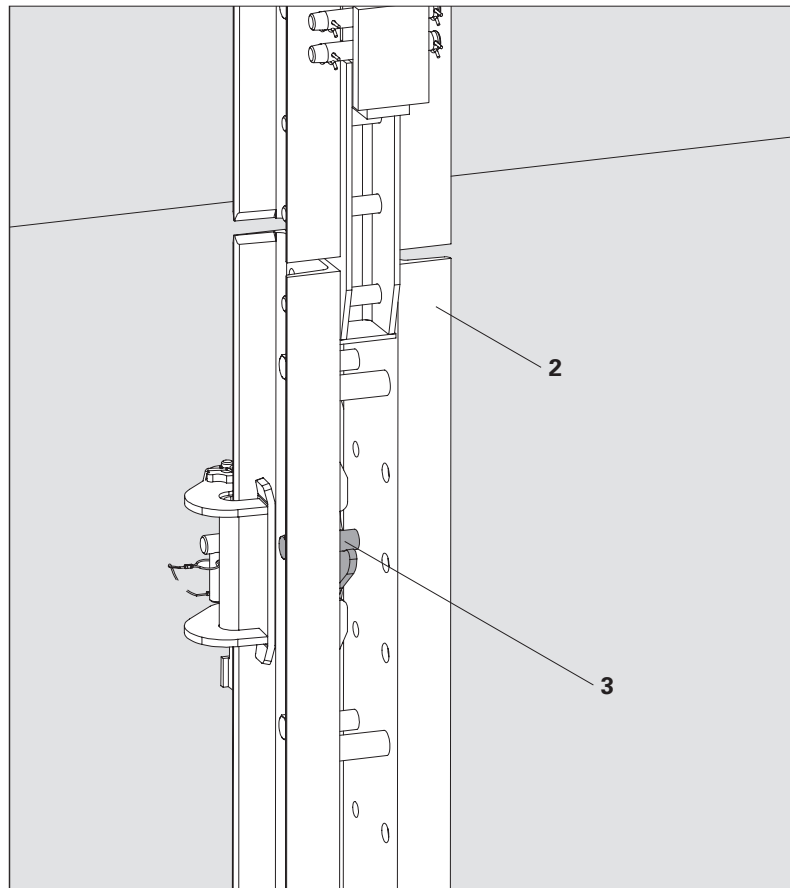

Fig. B1.04

Support reactions

H_1 : Horizontal force on the top slab shoe (positive: tension, negative: compression)

H_3 : Horizontal force on the bottom slab shoe (positive: tension, negative: compression)

V: Vertical force on the slab shoe

Version 1

To ensure that the self-climbing hydraulics operate properly, the uppermost slab shoe is activated to absorb the vertical force.

Verify the structural stability of the anchoring (47a) for forces H_1 and V_1 . The load-bearing capacity of the anchoring can be decisive in determining the size and weight of the climbing formwork. Adhere to the edge distances (a) set out in approvals

Z-21.6-1766 PERI Screw-On Cone

Z-21.6-1767 PERI Climbing Cone

Version 2

To reach the maximum load-bearing capacity of the anchoring, the vertical force is introduced at the middle climbing shoe.

Verify the structural stability of the anchoring (47a) with regard to the pure tensile force, and the anchoring (47b) with regard to the pure shear force.

For self-climbing operation, take the specified dimensions into account.

After the first stroke, introduce the vertical force into the upper anchoring. To do this, activate the upper climbing shoes and deactivate the middle climbing shoes.

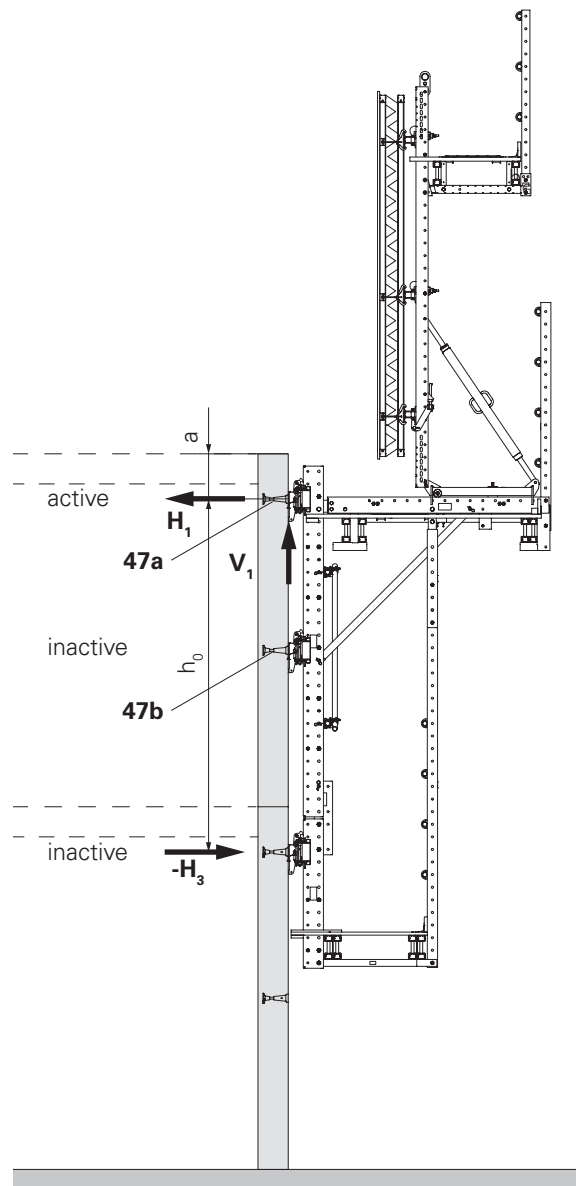

Fig. B1.06

Version 1

The vertical force is introduced at the upper climbing shoe.



- Refer to the project-specific calculation for the reaction forces acting on the anchoring and the building.
- The maximum reaction forces must be shown on the arrangement drawings.
- For all decisive load cases, statically verify the anchoring, the load introduction into the concrete and the transmission of forces in the building.

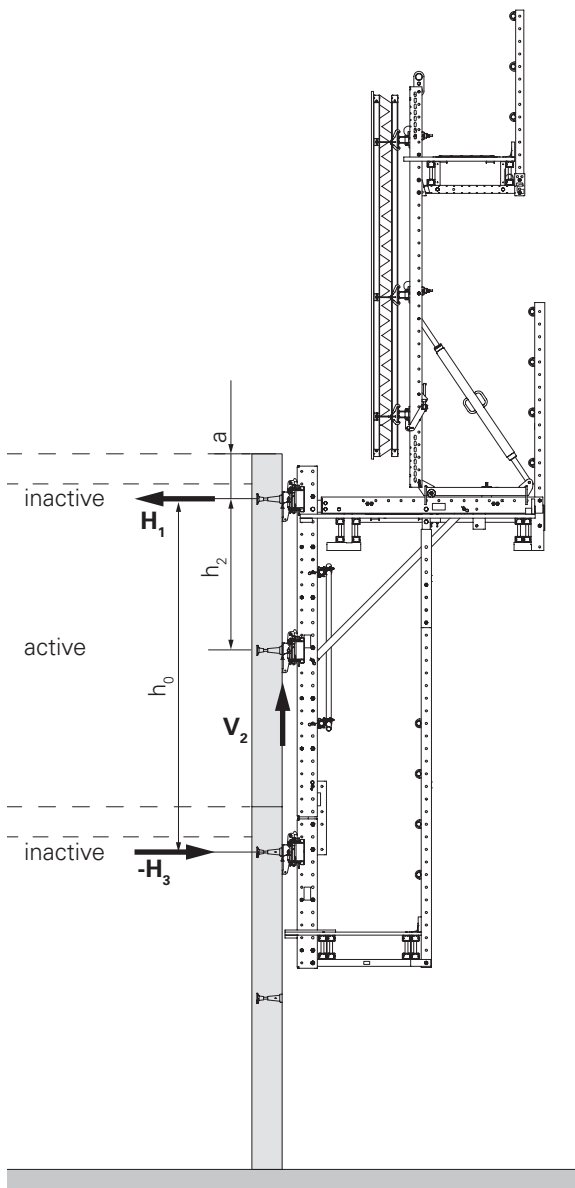

Fig. B1.06a

Version 2

The vertical force is introduced at the middle climbing shoe.

Load cases

A: Status: Working

Wind load from wind suction with $q(z) = 0.50 \text{ kN/m}^2$
 ($v = 102 \text{ km/h}$),
 100% live load on one level,
 50% live load on a second level.

B1: Status: Storm

max. wind load from wind pressure $w_e > 0$,
 no live loads.

B2: Status: Storm

max. wind load from wind suction $w_e < 0$,
 no live loads.

B3: Status: Storm

max. wind load from wind suction $w_e < 0$,
 no live loads.

$$w_e = C_s \times \chi \times \sum (c_F \times q(zE))$$

w_e = wind load [kN/m^2]

C_s = position coefficient

χ = service life factor for temporary constructions

c_F = force coefficient

$q(zE)$ = peak velocity pressure [kN/m^2]

Permissible wind speeds

State	Wind speed [v]	Wind pressure [q]
Working	72 km/h	0.25 kN/m ²
Climbing	64 km/h	0.20 kN/m ²
Non-operational	72 – 136 km/h	0.25 – 0.9 kN/m ²
Storm	136 – 188 km/h	0.9 – 1.7 kN/m ²

General

- Form the platform decking in the correct manner and in accordance with the applicable safety regulations.
- The material qualities must comply with the standards.
- Avoid – or at least cover – tripping hazards, unnecessary recesses and gaps in the deck.
- The distance between the lowest decking and the structure must not exceed 5 cm. Gaps in the deck must not exceed 2 cm.
- Fix immovable covering over any gaps between the decks of adjacent platforms when work is being carried out, e.g. with Cover Tape LPS or safety nets with a mesh size of max. 2 cm.
- Any openings in the decking that are required for normal working procedures must be covered with suitable immovable materials.
- If necessary, mount intermediate platforms on the formwork so that tie points can be operated safely.
- None of the decks on any of the platforms are designed to act as safety scaffolds. For safety scaffolds the planking must be dimensioned according to DIN 4420-1.

Work platform planking

Depending on the design of the working scaffold:

Load class 4 with max. load of 300 kg/m².

Load class 3 with max. load of 200 kg/m².

complies with DIN EN 12811-1.

Solid Wood Strength Class C24 – EN 338; Coniferous Wood Grade S10. Minimum dimensions of the planking: $b \times d = 24 \times 4$ cm or 20×4.5 cm.

PERI recommends bolting the individual planks to a transverse squared timber at the cantilever arm and in the centre of the bay if the plank thickness is less than 4.5 cm.

Minimum dimensions $w \times d = 12 \times 4$ cm.

Alternatively:

1. Multi-layered plywood sheeting made of laminated veneer lumber according to EN 14374 with a minimum thickness of 39 mm and a durability class of 4 or better.
2. Strength class C16 for solid wood EN 338: Minimum dimensions of planks $w \times d = 24 \times 5$ cm.

As safety scaffold for fall heights up to 3.00 m, double covering with planks $w \times d = 24 \times 5$ cm is required – see DIN 4420-1.

Plank decking of the finishing platform

Working scaffold of load class 2 max. load 150 kg/m² according to DIN EN 12811-1.

Solid Wood Strength Class C24 – EN 338; (Coniferous Wood Quality Grade S10).

Minimum dimensions of the planking: $w \times d = 20 \times 4$ cm.

PERI recommends bolting the individual planks to a transverse squared timber at the cantilever arm and in the centre of the bay if the plank thickness is less than 45 mm.

Minimum dimensions $w \times d = 12 \times 4$ cm.

Alternatively:

1. Multi-layered plywood sheeting made of laminated veneer lumber according to EN 14374 with a minimum thickness of 39 mm and a durability class of 4 or better.
2. Strength class C16 for solid wood EN 338: Minimum dimensions of planks $w \times d = 24 \times 5$ cm.



When using planking with a lower strength class or plywood boards, static verification is required.

Platform beams

Dimensioning the platform beams

For permissible span widths and cantilever arms of the platform beams for the work and finishing platforms, see Product Information PI 331.

Additional tilt bracing may be required for the platform beams.

Platform bracing

Screw down the plank diagonals underneath the platforms. Min. $w \times d = 20 \times 4$ cm screwed down.

Use 2x wood screws 6x80 SK-TX30 HPI to secure each plank.

Fixing the platform beams

The number of fasteners relates to one supporting point respectively. Therefore, the required number is 4 per platform in the standard case.

Work platform with

Crossbeam Head RCS/VARIO (22)

Crossbeam Unit RCS 220 VARIO (21)

Platform beam (GT 24 here) (75).

Double girder position

Fixing with 2x F.H. bolts M8 x 200 MU (112) + washer (121).

As an option to prevent lifting: 2x wood screws. 6x60 SK-TX30 HPI (126).

(Fig. B2.01 – B2.01b)



- For M8 truss-head screws, pre-drill the platform beam with a hole measuring $\varnothing 8$.
- For $\varnothing 8$ wood screws, pre-drill the platform beam with a hole measuring $\varnothing 5$.
- For 6x80 SK-TX30 HPI wood screws, do not pre-drill the platform beam.

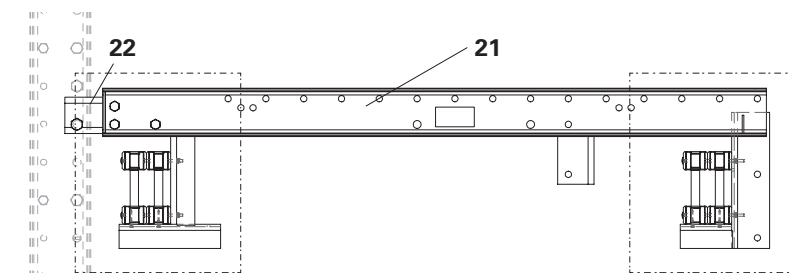

Fig. B2.01

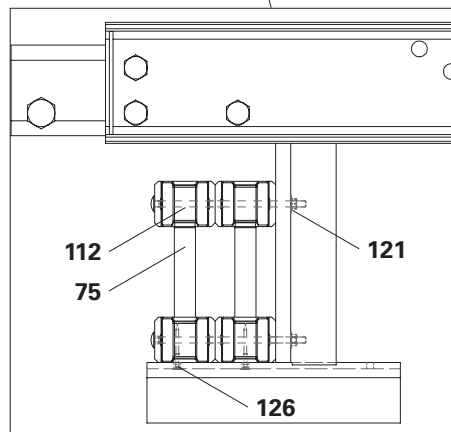

Fig. B2.01a

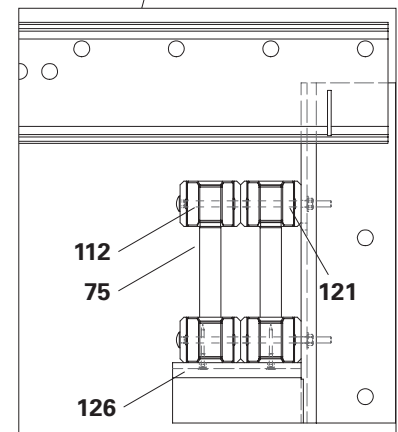

Fig. B2.01b

Single girder position

Fixing with 2x F.H. bolts M8 x 100 MU (110).

(Fig. B2.02 – B2.02b)

As an option to prevent lifting: 1x wood screws. 6x60 SK-TX30 HPI (126).



- Pre-drill the platform beam for M8 truss-head screws with a hole measuring $\varnothing 8$.
- When using VT 20:
Screw the upper chord into the crossbeam through the lower hole (21.1). (Fig. B2.03)
- For cantilevers over 1 m, screw the beams together at the top chord.

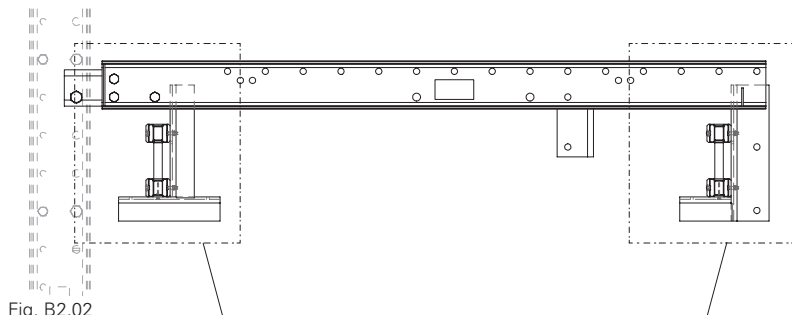

Fig. B2.02

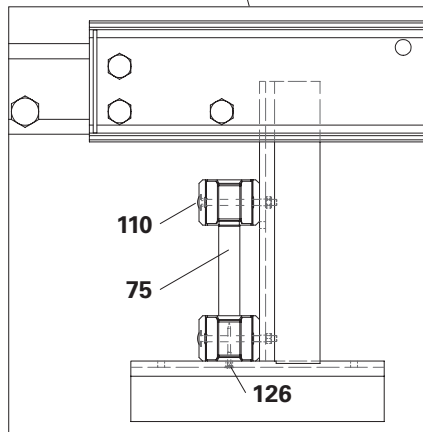

Fig. B2.02a

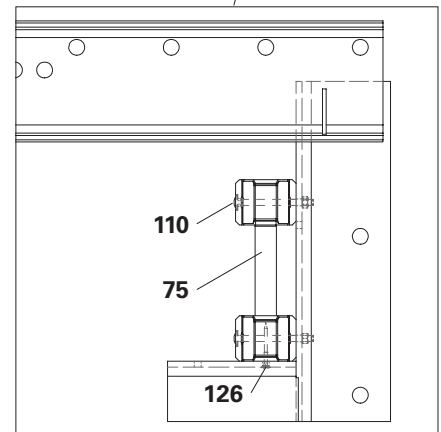

Fig. B2.02b

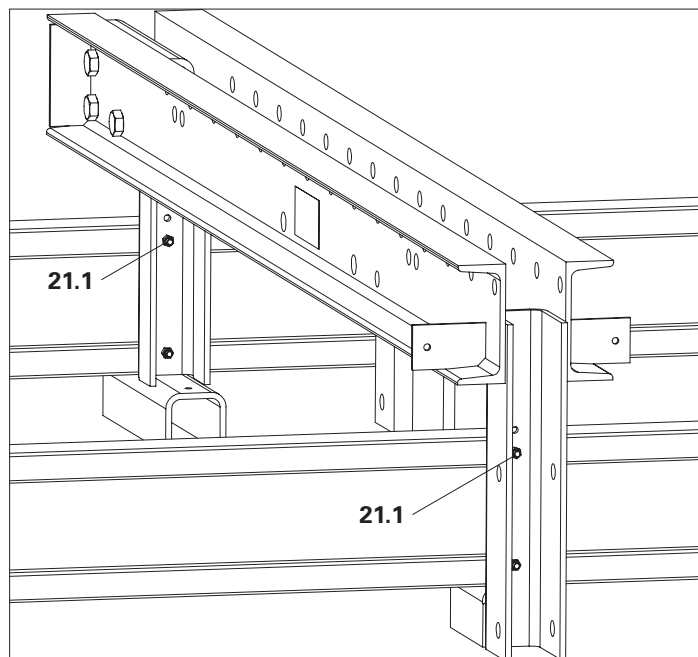

Fig. B2.03

Finishing platform

Finishing platform beam (34)
Platform beam (GT 24 here) (75)

Single girder position:

Fasten with
4x hex. wood screw 8 x 80 (138)
alternatively with wood screws 6x80
SK-TX30 HPI (125).
(Fig. B2.04 + B2.04a)

Double girder position:

Fasten with
2x F.H. bolts M8 x 200 MU (112) +
washer (121).
(Fig. B2.05 + B2.05a)



- For M8 truss-head screws, pre-drill the platform beam with a hole measuring $\varnothing 8$.
- For $\varnothing 8$ wood screws, pre-drill the platform beam with a hole measuring $\varnothing 5$.
- For 6x80 SK-TX30 HPI wood screws, do not pre-drill the platform beam.

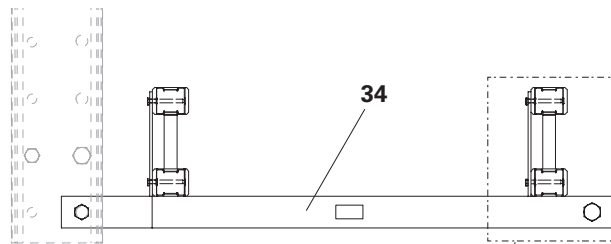

Fig. B2.04

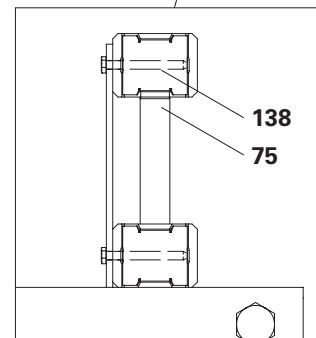

Fig. B2.04a

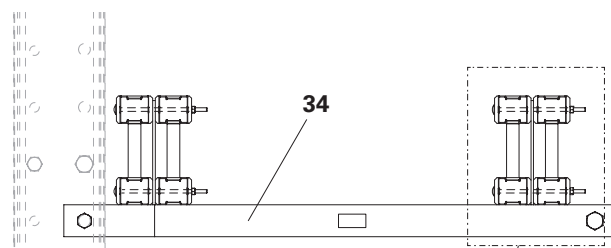

Fig. B2.05

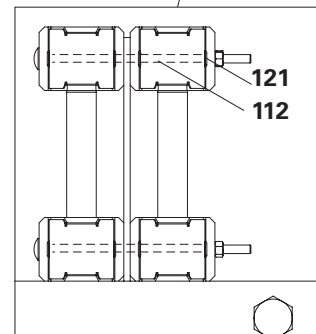

Fig. B2.05a

Planking

Assembly

Screw down each plank (76) at every intersection with a platform beam (75) using 2x wood screws 6x80 SK-TX30 HPI (125), $e = 120$ mm.



Prevent cantilevered planking and deck supports from lifting off using suitable fasteners!

For cantilevers greater than those specified in Product Information PI 331, structural verification is required.

In mitre and cut-out areas, where support for the planking is not guaranteed on both sides, install multi-layer plywood sheets.

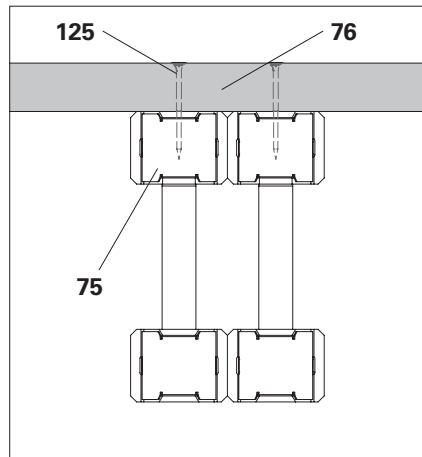

Fig. B2.06

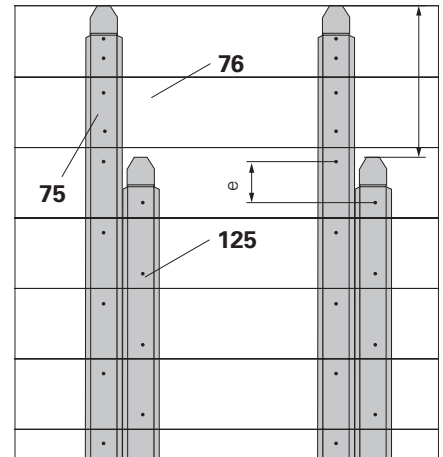

Fig. B2.07

Toe boards

Requirements:

Toe boards made of solid wood C24. Minimum dimensions $d/b = 3/15$ cm shown Planking (76) for the work platform.

Assembly

Alternative 1:

Screw down the toe board (77) with end-to-end squared timber 6/6 cm (98) and wood screws 6x80 SK-TX30 HPI (125) and wood screws 6x100 SK-TX30 HPI (132) at a spacing of approx. 50 cm.

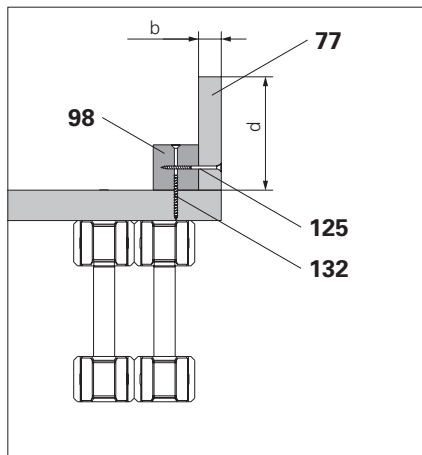

Fig. B2.08

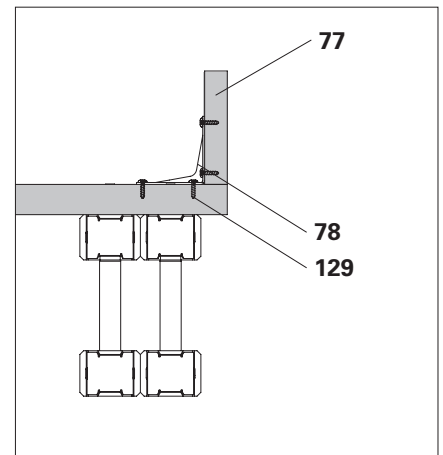

Fig. B2.09

Alternative 2:

Screw the 90° angle connector (78) onto the toe board (77) with 4x wood screws 5x20 SK-TX20 HSX (129) at a distance of approx. 1 m. Screw each squared timber angle connector onto the planking with 4x wood screws 5x20 SK-TX20 HSX (129).

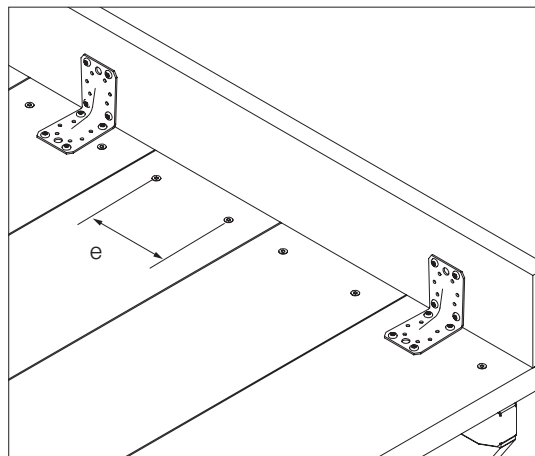

Fig. B2.10

Work platforms

Application variant for VARIO and TRIO formwork. (Fig. B2.11 + B2.11a)

Opening for hinged hatch

57 x 72 cm opening in the deck.
Screw an additional support 120/40 mm, onto the side of the end-to-end planks with at least 4x F.H. screws DIN 603 M8 x 125 (**114**) + washers A8 ISO 7093 (**120**). Bore \varnothing 8 mm.

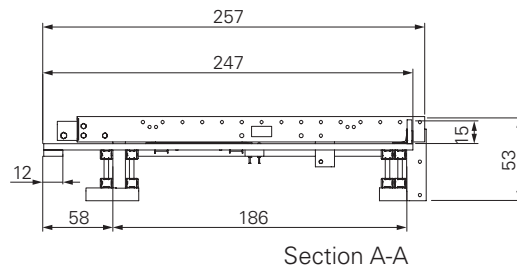

Fig. B2.11a

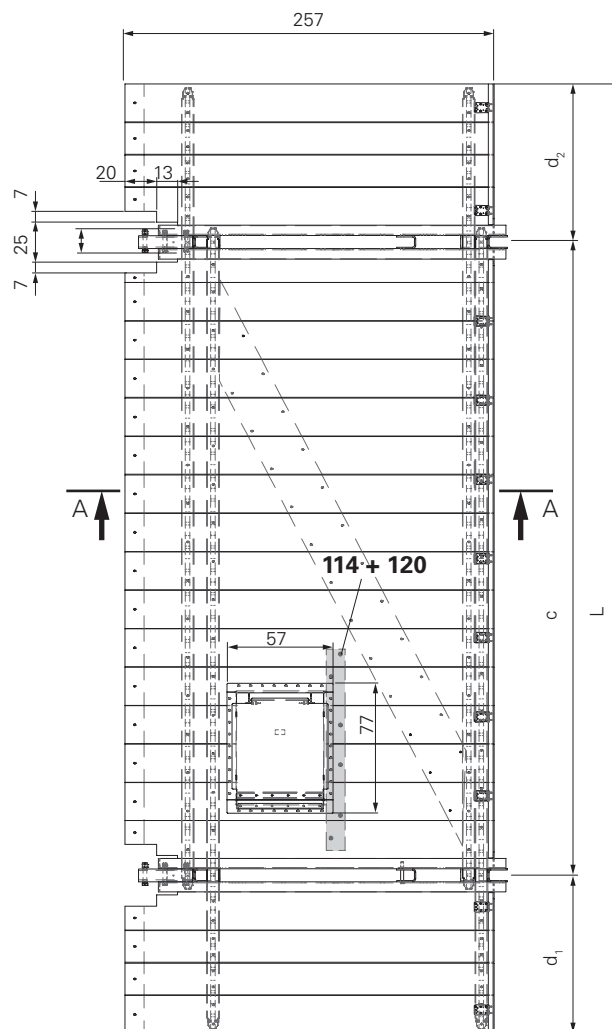
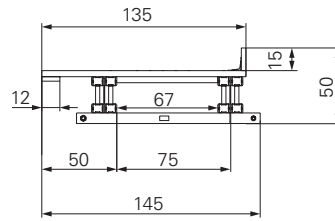

Fig. B2.11

Finishing platform

To avoid having to cut off the platform beams, use double beams that are shifted up against each other. (Fig. B2.12)



Section A-A

Fig. B2.12a

Deck coverings

For climbing rails or climbing rail extensions, cut the deck coverings (99) to size and fix them in place on the mounted planking with wood screws 6x60 SK-TX30 HPI (126).

Cover for climbing rail. (Fig. B2.12b)

Cover for climbing rail extension. (Fig. B2.12c)

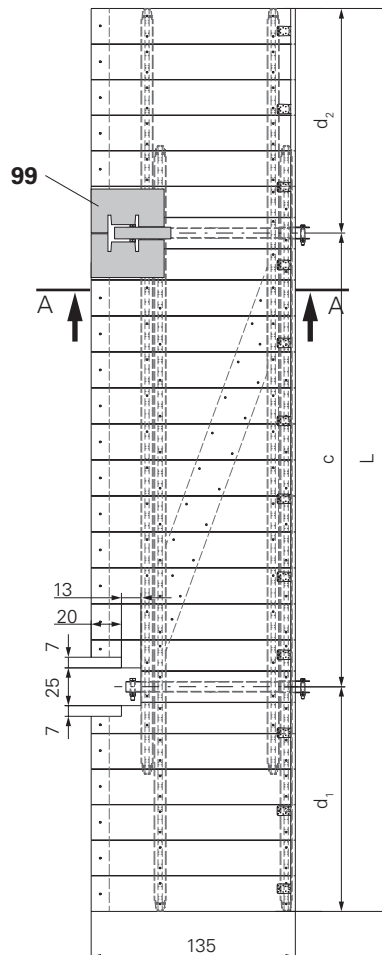

Fig. B2.12

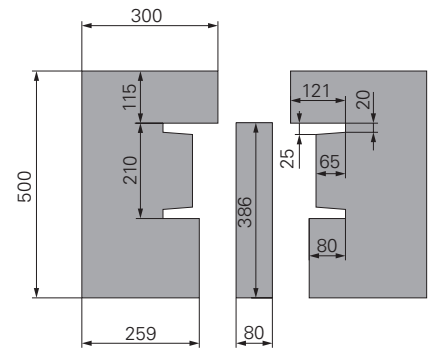

Fig. B2.12b

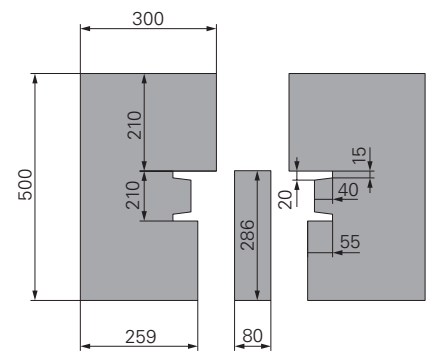

Fig. B2.12c

General information

Decking on corner and internal platforms should be formed in such a way that they do not hinder the climbing process.

Fit lateral guardrails at the front, see Section "B5 Planning guardrails" on page 52.

All the dimensions provided are merely examples. These must be checked and determined on a project-by-project basis.



Secure all cantilevered platforms on the opposite side to prevent them from lifting off.

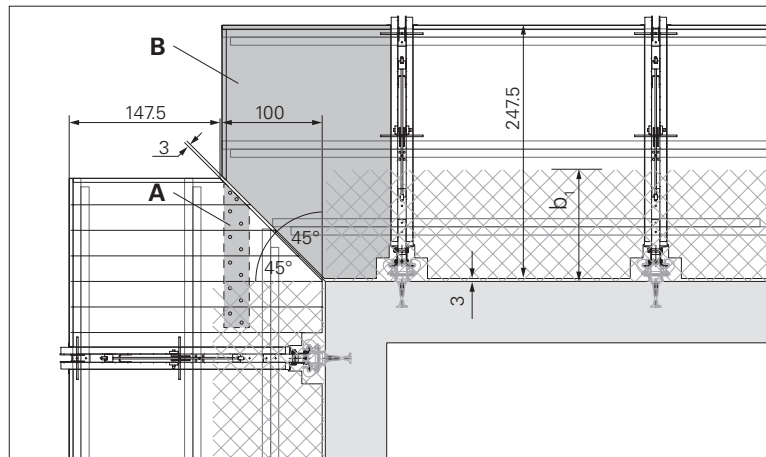

Fig. B3.01

Work platforms

When the formwork is retracted (hatched area b_1), it must be possible to transition from one platform to the next without any issues. The minimum passage width must not be less than 50 cm.

Mitred work platform, truncated

Guide the platform beams up to the edge of the platform. Screw down cantilevered planking with planks screwed underneath at right angles to the direction of the planking (A).

Alternatively, fit a multi-layered plywood sheet for corner areas (B).

Cover the mitre gap. (Fig. B3.01)

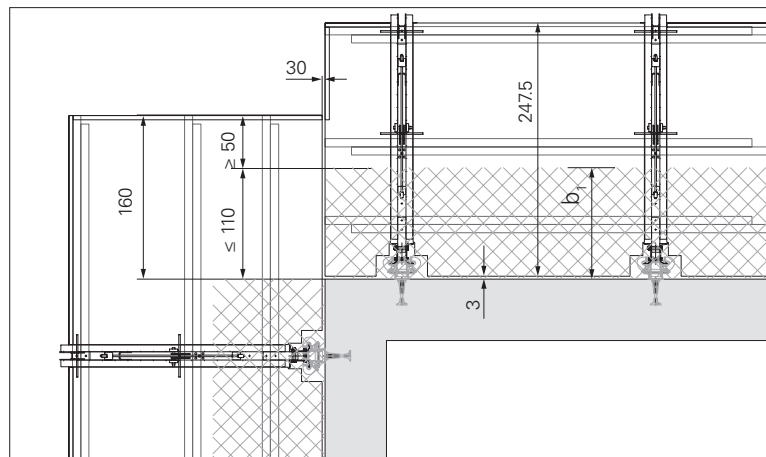

Fig. B3.02

Overlapping work platform

Cover the platform gap.

(Fig. B3.02 + B3.03)



In order to ensure that the cantilever arms of the platform beams are permissible, minimise the distance between the console bracket and the corner of the projecting platform.

Attention – it may be necessary to produce precise static verification for the anchoring.

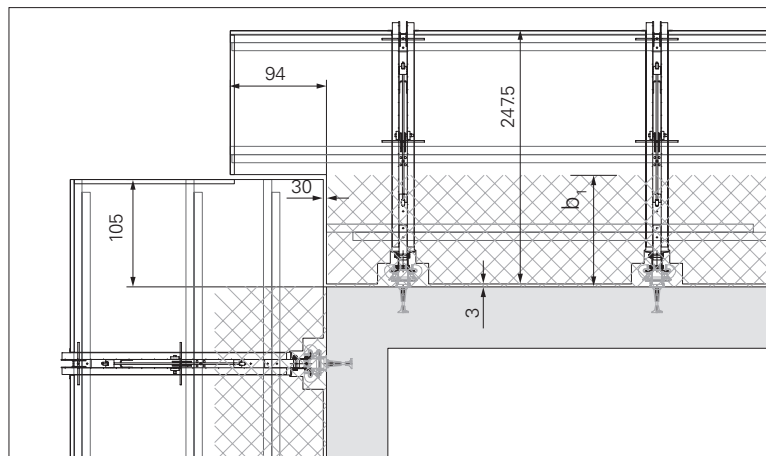

Fig. B3.03

Finishing platform

It must be possible to transition from one platform to the next without any issues. The minimum passage width must not be less than 50 cm. Fix immovable covering over any remaining gaps.

Mitred finishing platform

Guide the platform beams up to the edge of the platform. Screw down cantilevered planking with a plank screwed underneath at right angles to the direction of the planking (A).

Alternatively, fit a multi-layered plywood sheet for corner areas (B).

Cover the mitre gap. (Fig. B3.04)

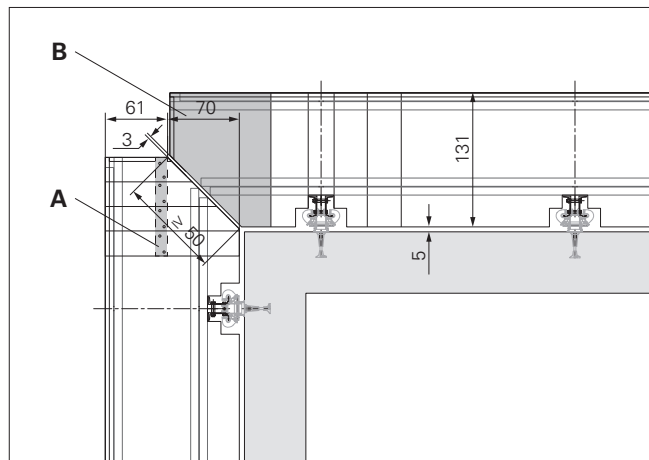

Fig. B3.04

Overlapping finishing platform

Cover the remaining beams in the platform. (Fig. B3.05)

Recommended distance to the structure 50 mm, to adjacent platform 30 mm.

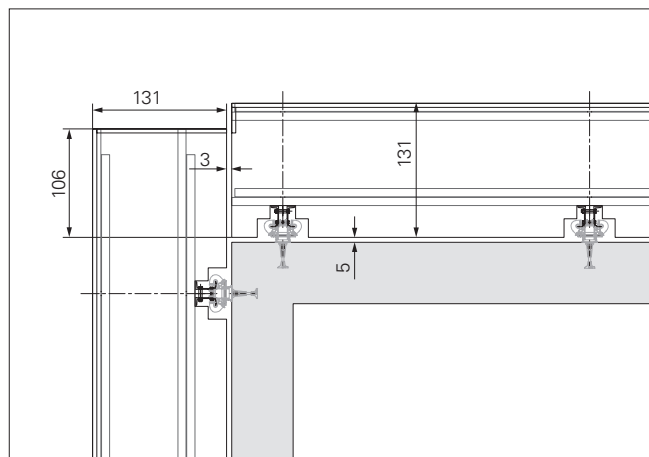

Fig. B3.05

Concreting platform

It must be possible to transition from one platform to the next without any issues. The minimum passage width must not be less than 50 cm.

Mitred concreting platform

Guide the platform beams up to the edge of the platform. Screw down cantilevered planking with planks screwed underneath at right angles to the direction of the planking (A).

Alternatively, fit a multi-layered plywood sheet for corner areas (B).

Cover the mitre gap. (Fig. B3.06)

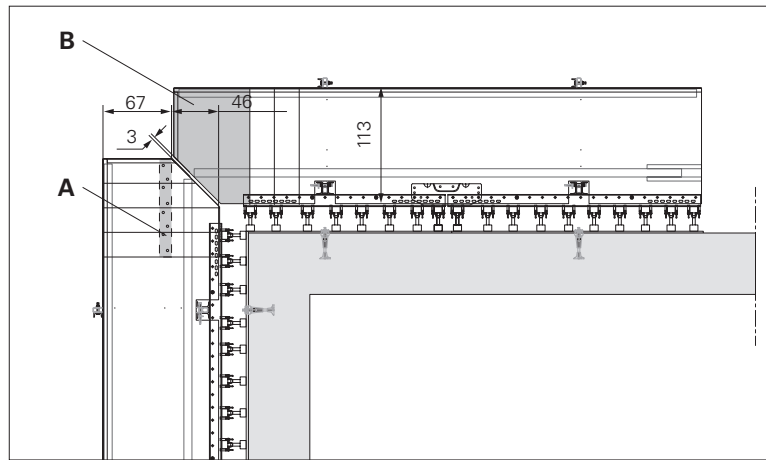

Fig. B3.06

Overlapping concreting platform

Move the platform decking of the overlapping platform closer to the adjacent platform in the transition area.

Screw down cantilevered planking with squared timber screwed underneath at right angles to the direction of the planking.

Cover the remaining gap in the platform. (Fig. B3.07)

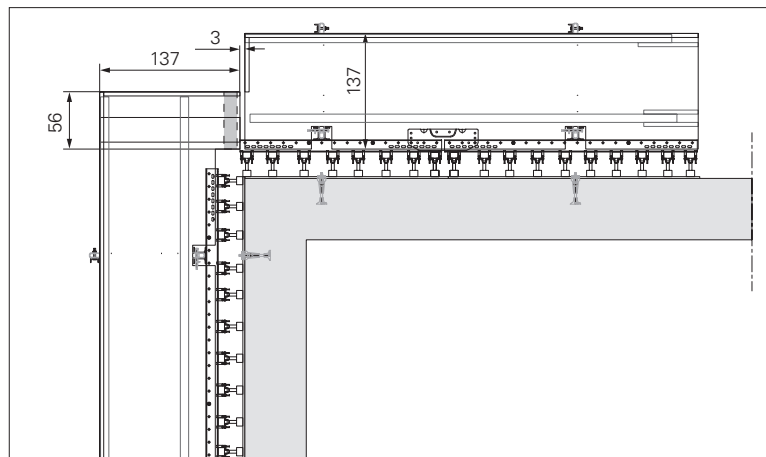

Fig. B3.07

Parallel console bracket arrangement

To ensure that the carriage functions properly, arrange the console brackets in parallel on round structures.

Screw the rotatable wall shoe (53) onto the anchoring (47). Fit the climbing shoe (50) onto the rotatable wall shoe.

The rotatable wall shoe compensates for contortions of up to $\alpha = 15^\circ$ between the axes of the anchoring and the truss section.



Separate static verification is required for the wall shoe and the anchoring.

The minimum radius for use of the rotatable wall shoe subject to the tie spacing c is calculated as:

$$R \geq \frac{c}{2 \times \sin(15^\circ)} \approx 2 \times c$$

Recommended distance to the structure 50 mm, to adjacent platform 30 mm.

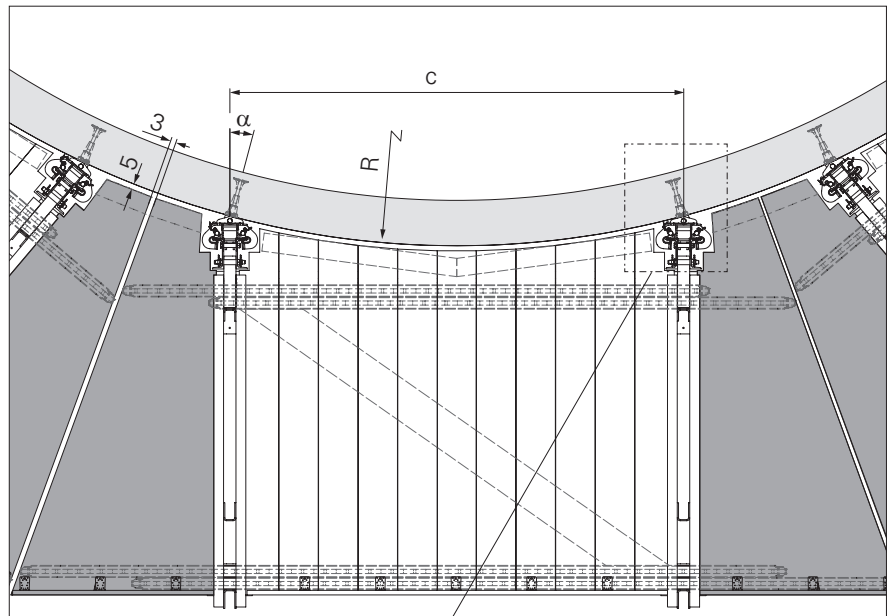

Fig. B4.01

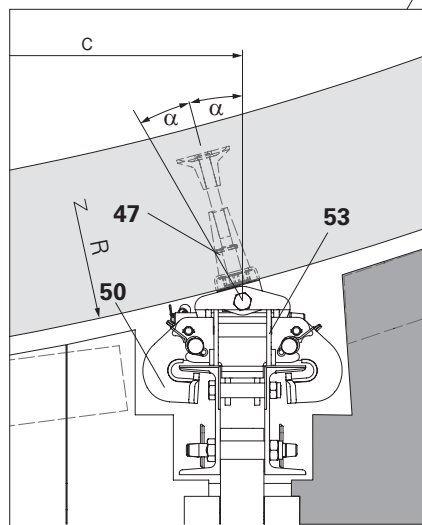

Fig. B4.01a

Radial console bracket arrangement

When the climbing brackets are arranged in a radial manner, the formwork cannot be moved backwards onto the carriage.

Therefore, after a section has been climbed, the wall and climbing shoes must be mounted between the formwork and the work platform.

In addition, special measures should be taken for the platform beam fastening and the bracing with scaffolding tubes.

Recommended distance
to the structure 50 mm,
to adjacent platform 30 mm.

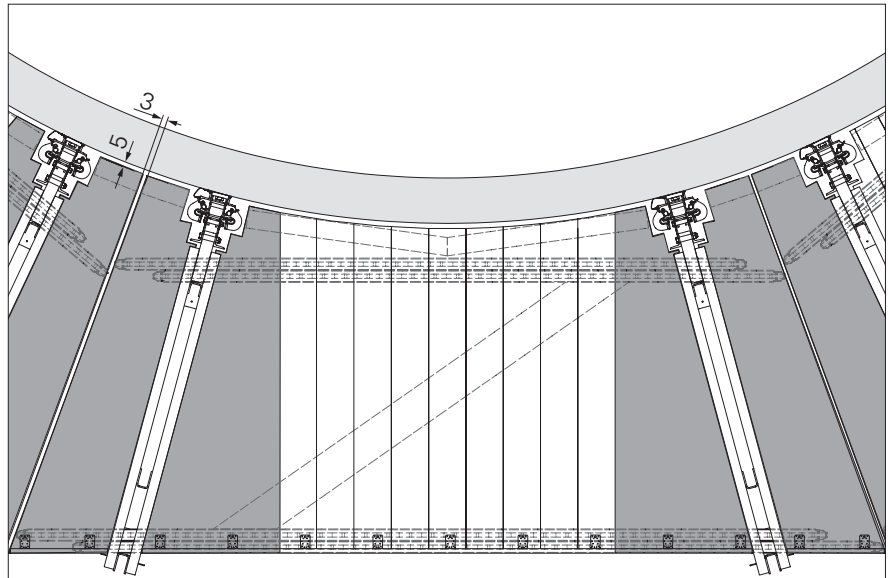

Fig. B4.02

Guardrails

General requirements

Guardrails and lateral protection must be fitted according to valid safety regulations.

Guardrails must be fitted onto all leading edges and on all platform levels.

High working positions must be secured in order to prevent objects falling to the ground. To this end, fit safety nets or lateral protection with closed protection panels.

The following can be used as lateral protection:

- Guardrail boards,
- Galvanised steel scaffolding tubes $\varnothing 48.3$ or $\varnothing 60.3$,
- Squared timber with enclosure made of netting, tarpaulin, plywood or trapezoidal metal sheeting.

(Fig. B5.01)

Ladder cage with guardrail boards

Requirements:

Guardrail boards (**82**) made of solid wood C24,

Dimensions $t/w = 3/15, 4/12$ or $5/12$ cm or according to the static verification.

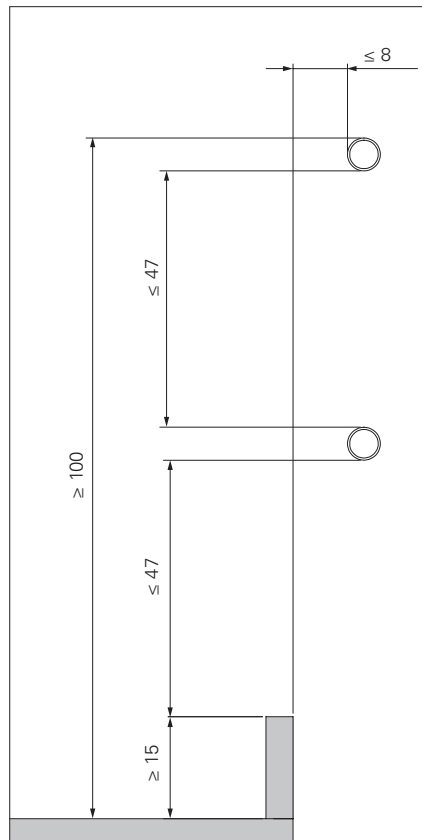

Fig. B5.01

Components

79 Guardrail Post U100 225 RCS

82 Guardrail boards

111 F.H. Bolt DIN 603 M8 x 70 MU

1. Screw the guardrail boards to the inside of the guardrail posts (**79**) at intervals of $a = 50$ cm using DIN 603 M8 x 70 MU truss-head screws (**111**).

(Fig. B5.02)

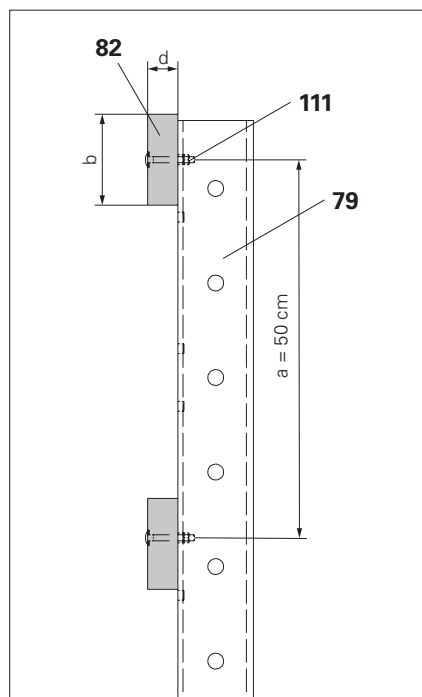

Fig. B5.02

Ladder cage with scaffolding tubes

Requirements:

Steel scaffolding tubes (**88**), minimum quality S235.
 Dimensions $\varnothing \times t = 48.3 \times 3.2$ or 60.3×4.5 mm.

Components

- 79** Guardrail Post U100 225 RCS
- 88** Steel scaffolding tube $\varnothing 48.3 \times 3.2$
- 89** Clamp A64 DIN 3570
- 89.1** Hex. Nut ISO 4032 M12-8

1. Insert scaffolding tubes into clamps A64 DIN 3570 (**89**) and screw them into place on the inside with hex. nut ISO 4032 M12-8 (**89.1**), for example onto the guardrail posts (**79**). (Fig. B5.03)

Connect or support the scaffolding tubes at the ends and in the centre of the bay with vertical scaffolding tubes. This prevents overloading.

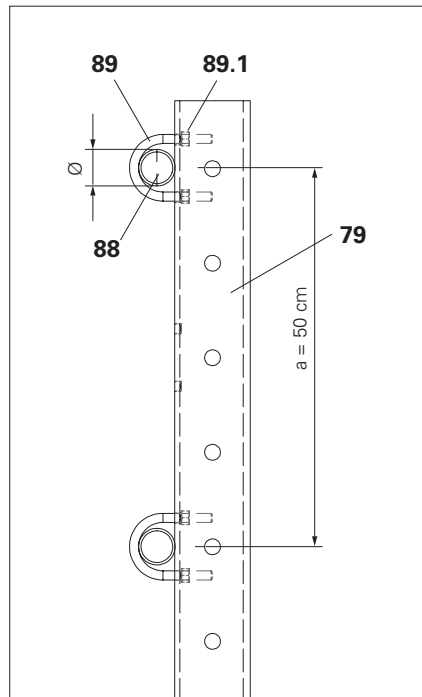

Fig. B5.03

Fitting safety nets

1. Attach the safety net according to the manufacturer information.
2. Guide the lower edge of the safety nets towards the building.
3. Ensure that there is a sufficient overlap with other parts of the enclosure.



Mesh size for enclosure nets ≤ 20 mm.
 Scaffolding tube spacing $a = 50$ cm.
 (Fig. B5.04)

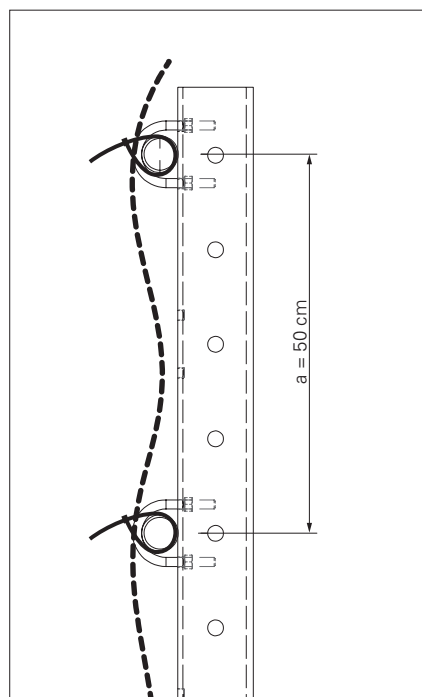

Fig. B5.04

Lateral guardrails



- Lateral side protection is required to be installed on all end platforms without adjacent platforms.
- For alternative fixing possibilities: see PI Sheet 375.
- The length of the guardrails and toe boards must correspond to the width of the platforms.
- If the platform beams are only slightly displaced, screw the Multi guardrail post holders in tight before installing the platform beams. Screw holes may otherwise be covered. (Fig. B5.05a)

Components

- 15** Filler pin Ø 21 x 120
- 16** Cotter pin 4/1
- 77** Toe board 30 x 150 mm
- 90** Guardrail Post SCS 150
- 94** Guardrail Post Holders Multi
- 109** F.H. Bolt DIN 603 M8 x 45 MU
- 120** Washer ISO 7094 200 HV, A8
- 126** Wood screw 6x60 SK-TX30 HPI

Assembly

1. Fix guardrail post holder multi (**94**) to the platform beam (**75**) using 12x wood screws 6x60 SK-TX30 HPI (**126**).
2. Install Guardrail Post SCS 150 (**90**) using 2x filler pins Ø 21 x 120 (**15**) and cotter pins 4/1 (**16**) in each case.
3. Fit the guardrail, see the following Section.
4. Fix toe board (**77**) to the guardrail post holder multi (**94**):
 - Pre-drill (Ø 9 mm) toe board.
 - Fix the toe board in place using F.H. bolts DIN 603 M8 x 45 MU (**109**) and washers ISO 7094 200 HV, A8 (**120**).

(Fig. B5.05)

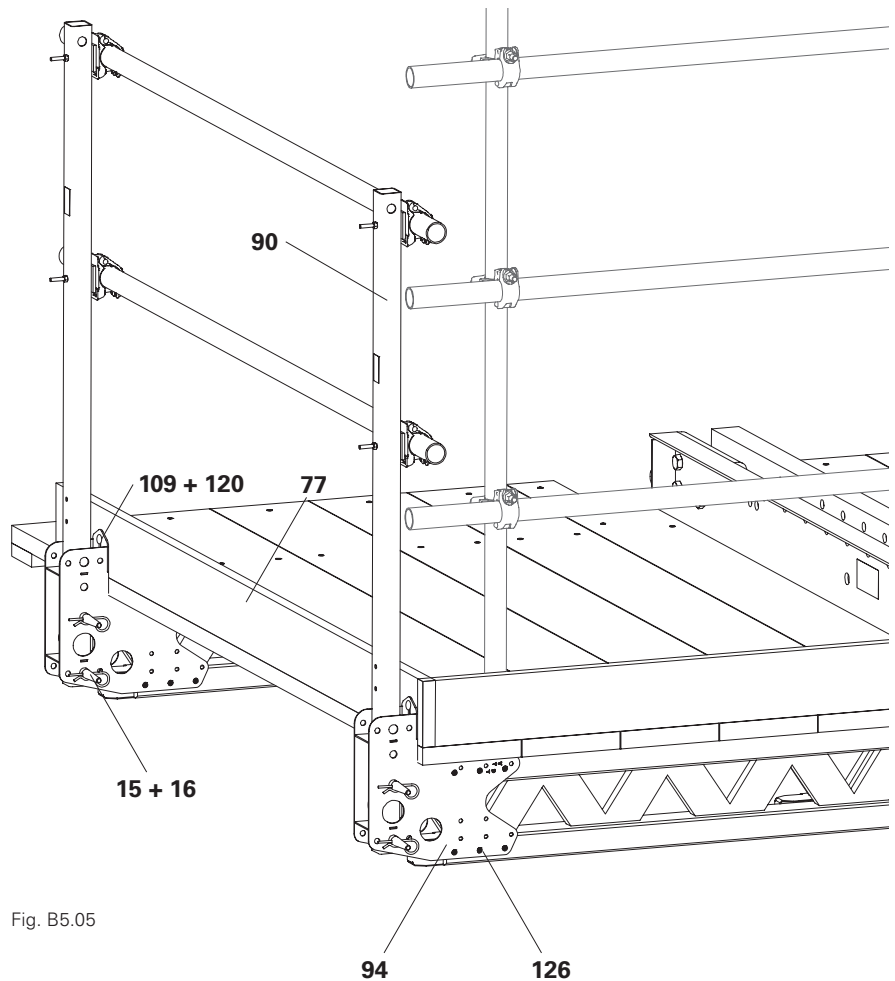

Fig. B5.05

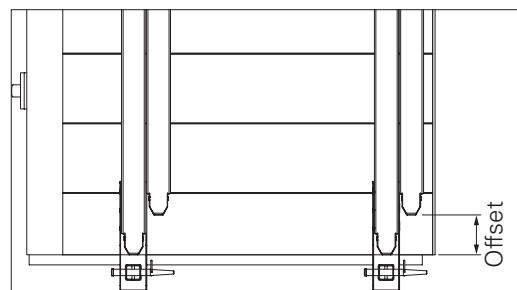

Fig. B5.05a

Mounting the Handrail Boards

Components

- 82** Guardrail board
- 90** Guardrail Post SCS 150
- 110** F.H. Bolt DIN 603 M8 x 100 MU

Assembly

2. Position guardrail board (**82**) L x 12 x 4 cm on Guardrail Post SCS 150 (**90**).
3. Pre-drill the guardrail board (Ø 9 mm).
4. Screw the guardrail board onto Guardrail Post RCS 150 (**90**) with F.H. bolts DIN 603 M8 x 100 MU (**110**). (Fig. B5.06)

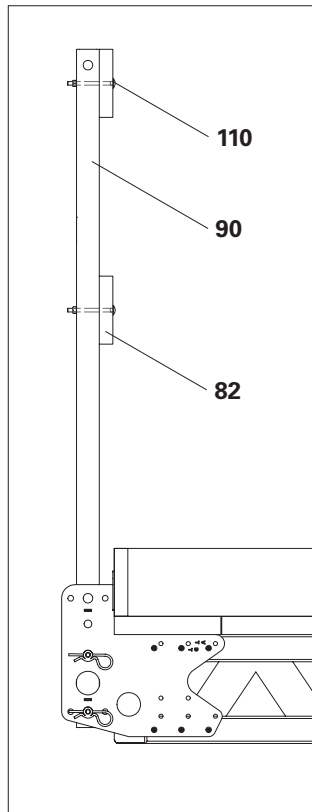

Fig. B5.06

Installing the scaffolding tubes

Components

- 88** Steel scaffolding tube Ø 48.3 x 3.2, special length
- 90** Guardrail Post SCS 150
- 93** Guardrail Post Connector CB
- 110** F.H. Bolt DIN 603 M8 x 100 MU
- 120** Washer ISO 7094 200 HV, A8

Assembly

1. Mount Guardrail Post Connector CB (**93**) to Guardrail Post SCS 150 (**90**) using F.H. bolt DIN 603 M8 x 100 MU (**110**) and washer ISO 7094 200 HV A8 (**120**).
3. Insert the steel scaffolding tubes (**88**) and screw them tight. (Fig. B5.06a)

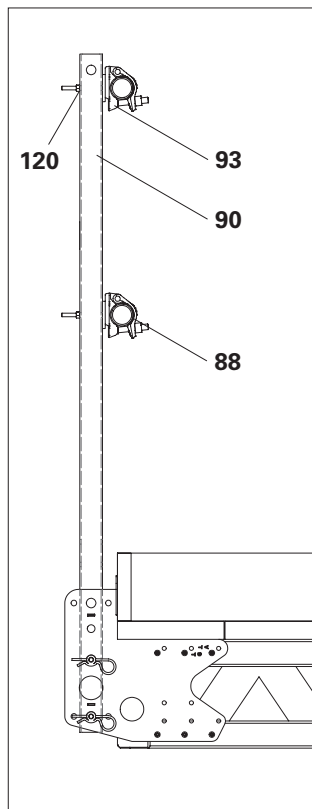

Fig. B5.06a

End-to-end lateral guardrail with guardrail boards

Components

75	Girder GT 24, e.g. 450
76	Planking
82	Guardrail boards
84	L-bracket RCS 120 x 120 x 200
98.1	Squared timber 10/12
102	Bolt ISO 4017 M12 x 140-8.8
107	Bolt ISO 4014-M20 x 150-8.8
115	Nut ISO 7040-M20-8
118	Nut ISO 7040 M12-8
122	Washer ISO 7094-A12-100HV
123	Washer ISO 7094-A20-100HV
125	Wood screw 6x80 SK-TX30 HPI



Not suitable as a supporting structure for enclosures!

1. For transferring force above the L-bracket (**84**), screw on planks (**76a**) transversely to the direction of the decking (**76**).
 2. Fix lateral planking to the planking as well as the planking on the platform beams (**75**) using wood screws 6x80 SK-TX30 HPI (**125**).
 3. Pre-drill lateral planking and planking with holes measuring \varnothing 13 mm.
 4. Screw the L-bracket (**84**) to the lateral planking and planking with 2x hex. screws M12 x 140 (**102**), large washers (**122**) and nuts (**118**).
 5. Pre-drill the vertical squared timber 10/12 (**98.1**) with holes measuring \varnothing 22 mm and screw it to the L-bracket with hex. Screws M20 x 150 (**107**), large washers (**123**) and nuts (**115**).
 6. Screw the guardrail boards (**82**) to the vertical squared timber with wood screws 6x80 SK-TX30 HPI (**125**).
 7. To fit the toe board, see Section "Toe boards" on page 42.
- (Fig. B5.07 – B5.07b)

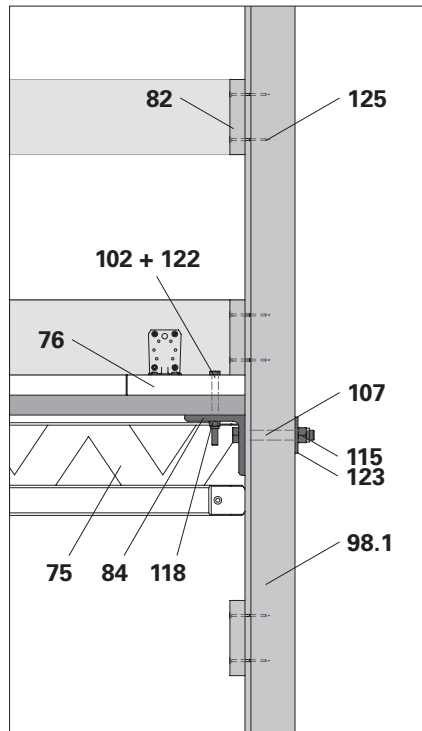

Fig. B5.07

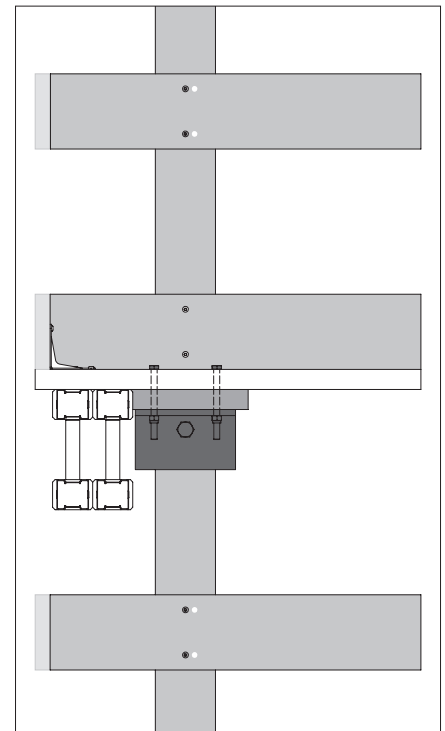

Fig. B5.07a

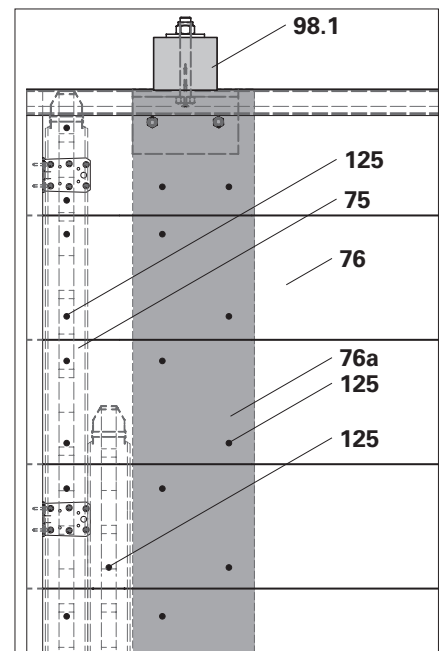

Fig. B5.07b

End-to-end lateral guardrail with scaffolding tubes

Components

- 75** Girder GT 24, e.g. 450
- 76** Planking
- 84** L-bracket RCS 120 x 120 x 200
- 88** Steel scaffolding tube \varnothing 48.3 x 3.2
- 95** Standard Coupler RA 48/48
- 96** Screw-on coupling-2 HT B D48-20
- 102** Bolt ISO 4017 M12 x 140-8.8
- 118** Nut ISO 7040 M12-8
- 122** Washer ISO 7094-12-100HV
- 125** Wood screw 6x80 SK-TX30 HPI



Not suitable as a supporting structure for enclosures.

1. For transferring force above the L-bracket (**84**), screw on planks (**76a**) transversely to the direction of the decking (**76**).
 2. Fix lateral planking to the planking as well as the planking on the platform beams (**75**) using wood screws 6x80 SK-TX30 HPI (**125**).
 3. Pre-drill lateral planking and planking with holes measuring \varnothing 13 mm.
 4. Screw the L-bracket (**84**) to the lateral planking and planking with 2x hex. screws M12 x 140 (**102**), large washers (**122**) and nuts (**118**).
 5. Screw the vertical scaffolding tube \varnothing 48 (**88**) onto the L-bracket with the screw-on coupling AK48 (**96**).
 6. Attach horizontal scaffolding tubes \varnothing 48 (**88a**) to the vertical scaffolding tube using Standard Couplers RA 48/48 (**95**).
 7. To fit the toe board, see Section "Toe boards" on page 42.
- (Fig. B5.08 – B5.08b)

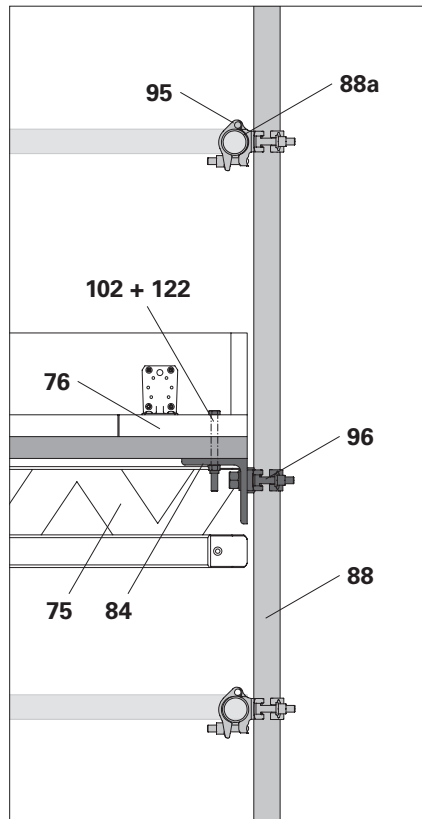

Fig. B5.08

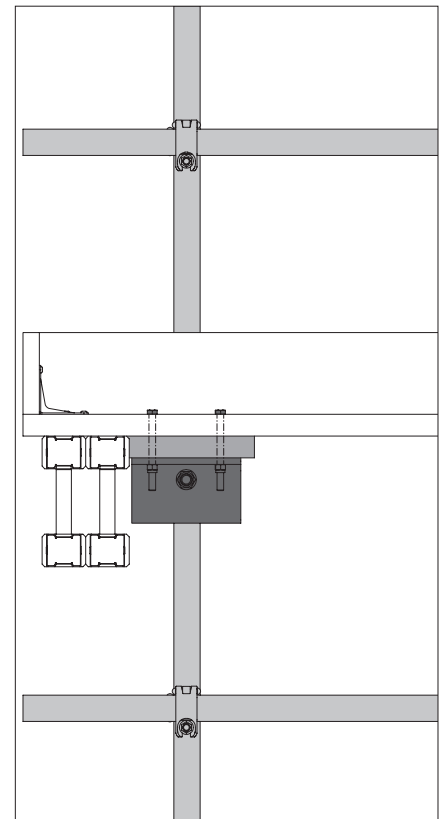

Fig. B5.08a

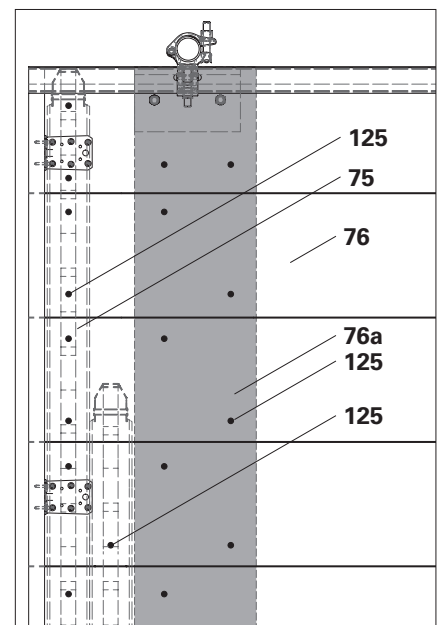

Fig. B5.08b

Position of the leading tie

VARIO:

Keep a distance of at least 3 cm between the leading tie axis and the adjacent girders so that the leading tie (42) can be fitted with the positioning screw (42.1). (Fig. B6.01)

TRIO:

Keep a distance of at least 3 cm horizontally and at least 4 cm vertically between the leading tie axis and the struts of the formwork so that the leading tie can be fixed with the positioning screw.

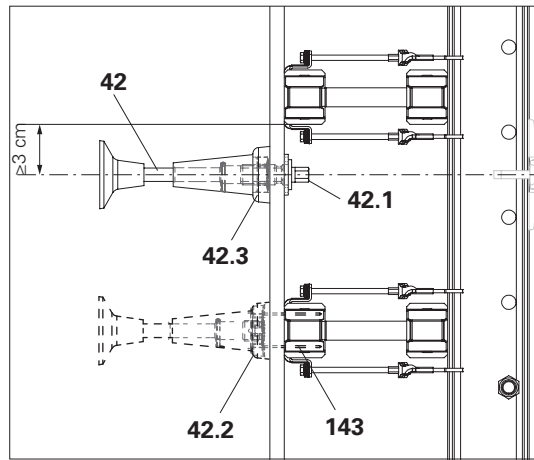

Fig. B6.01

Top view

If the tie position falls on struts (41.1) or girders, then fit the leading tie with an anchor positioning stud. Nail the Anchor Positioning Stud M30 (42.2) to the formlining with wire nails 3.0 x 80 (143). See Fig. B6.01 – Fig. B6.02a, bottom example in each case.

Components

42	Leading tie
42.1	Positioning screw
42.2	Anchor Positioning Stud M30
42.3	Anchor Positioning Plate M30
143	Wire nail 3 x 80

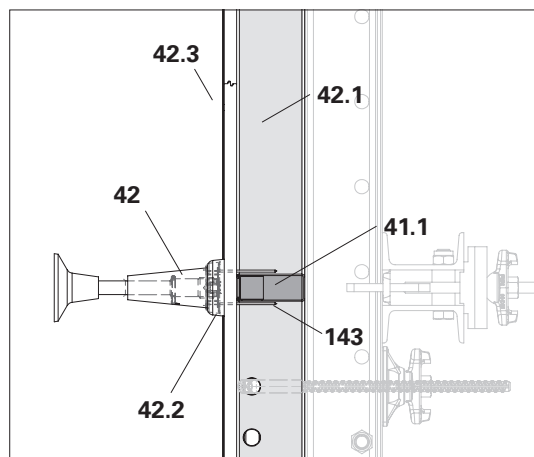

Fig. B6.02

Top view

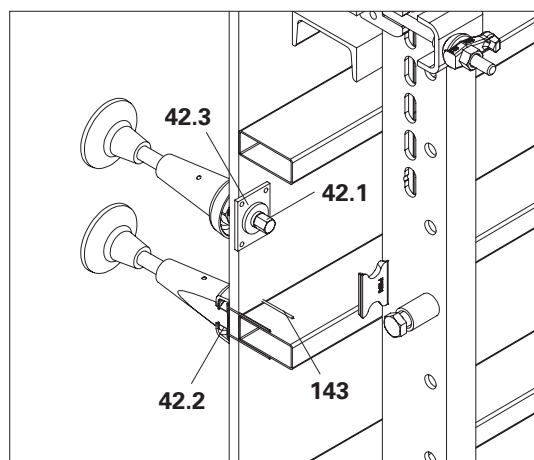

Fig. B6.02a

Planning the climbing sequence



Keep the following points in mind when planning the climbing sequence and putting together the work instructions:

- Arrange the finishing platforms, especially in the corner areas, in such a way that the unit can be transported from one climbing unit to the next without any problems. To do this, make the crossings sufficiently wide and without any steps.
- Form the decks, especially on corner and internal platforms, in such a way that they do not collide with the platforms or formwork of adjacent climbing units during the climbing process.
- Plan access and ladder descents in such a way that there is safe access to all climbing units at all times.
- The climbing sequence must be planned for the entire building. In doing so, determine a suitable route for the hydraulic hoses and a suitable way to climb the final climbing unit.
- Draw up a hydraulic plan for connecting the climbing devices and hydraulic hoses to the hydraulic units.
- Specify appropriate measures to cord off or secure the open building edges that appear.

Attachment point for crane

The size of climbing units may be restricted by the permissible load of the attachment point. For this, determine the weight of the relevant panels during the planning phase.

As a rule, attach the climbing unit to the Climbing Rail RCS.

When assembling and dismantling climbing units that are moved with the self-climbing device, also observe the permissible load of the attachment points.

Specify the weight of the climbing units in the general arrangement drawings.

Standard case: Climbing

Permissible total weight of the climbing unit

- when attached to climbing rail with 2 x Lifting Eye BR-2 2.5 t (9) max. 5 t,
- when attached 2 x directly to the spacer in the Climbing Rail RCS max. 9 t. (Fig. B6.03)

Repositioning

For attaching to the strongback, see the next section.

Assembly/dismantling

Attach assemblies in line with the following assembly and pre-assembly instructions.

Transportation by crane without climbing beam



Caution!

Trip hazard due to protruding squared timber! This can result in injuries.

⇒ Mark squared timber with a signal colour.

If, in exceptional cases, it is not possible to use a climbing beam, squared timber must be fitted between the upper ends of the strongback as a compression brace. To fix it in position, screw the squared timber to the concreting platform.

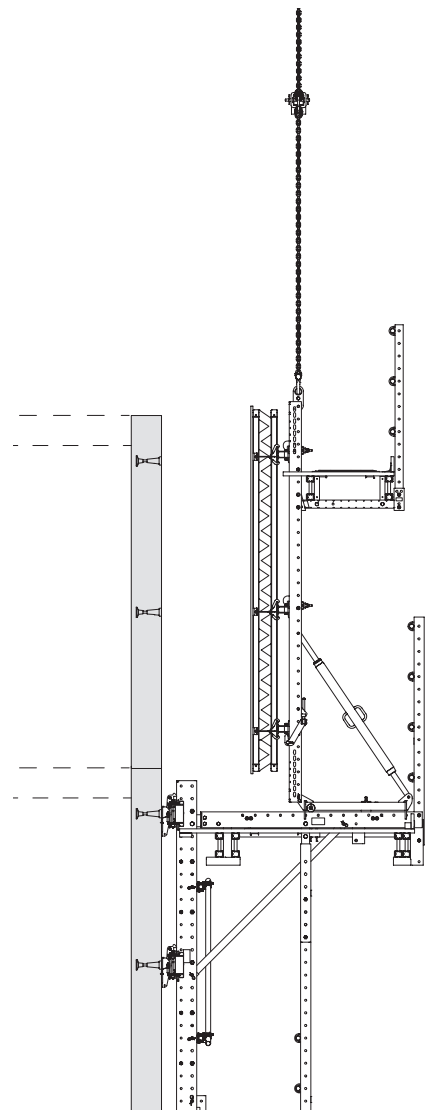

Fig. B6.03

Repositioning with the Climbing Beam 9 t



- Always lift and move climbing units with Climbing Beam 9 t (10).
- For safe attachment and removal of the crane hook, provide suitable measures to prevent falls.
- Refer to the corresponding assembly instructions for Climbing Beam 9 t and Lifting Eye BR-2 2.5 t (not shown)!
- Ensure loads are evenly balanced when they are picked up.

Components

- 4 Spacer M24-82
- 10 Climbing beam 9 t
- 25 Steel Waler Universal SRU

Attachment point:

Spacer (4) attached to uppermost hole of strongback (25).
Load-bearing capacity 5,000 kg.

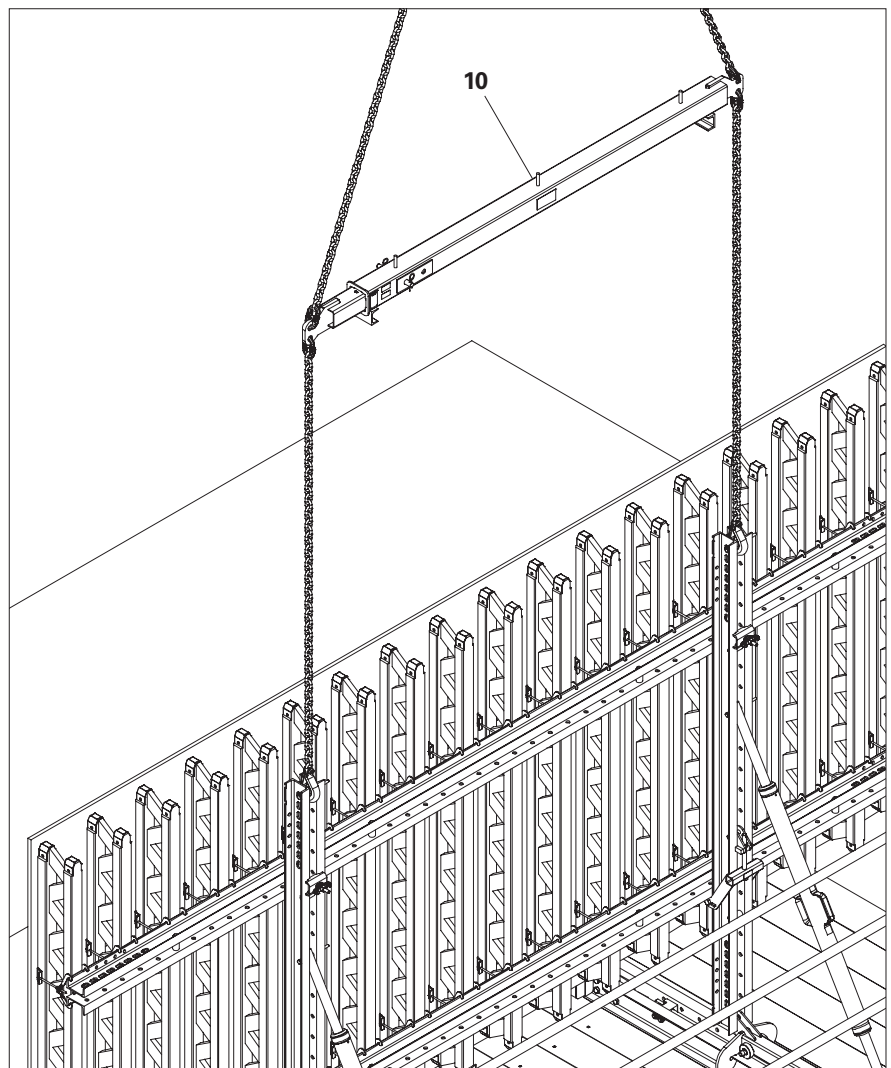

Fig. B6.04

Concreting platform not shown

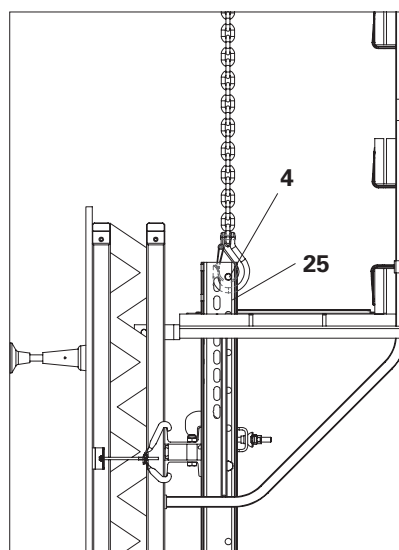

Fig. B6.05

Strongback on TRIO Panel Formwork

Components

- 15** Filler pin \varnothing 21 x 120
- 16** Cotter pin 4/1
- 25** Steel Waler Universal
SRU L = 2.72
- 26** Waler Fixation SRU
- 27** Height Adjustment Unit SRU
- 32** Waler
- 35** Strongback Adapter RCS/SRU
- 41** TRIO Element
- 139** Wingnut Pivot Plate DW 15
- 141** Hook Tie DW 15/400

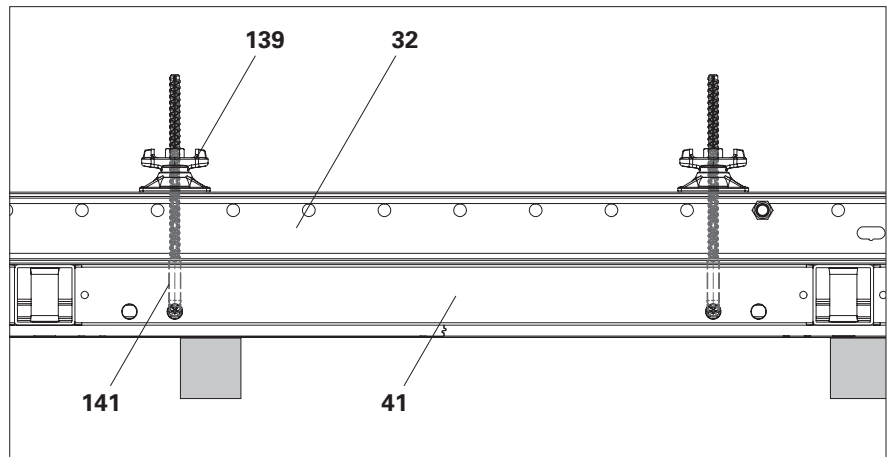

Fig. C1.01

1. Clamp the waler (**32**) to the specified position on the TRIO panel (**41**) with the Hook Tie DW 15 (**141**) and the Wingnut Pivot Plate DW 15 (**139**). (Fig. C1.01)



- Use at least 2 Hook Ties DW 15 (left and right) in the vicinity of the strongback. The hooks point upwards. (Fig. C1.01a)
- At least 8 hook ties are needed for each climbing unit.
- The waler must protrude at least 5 cm above the wingnut pivot plate.

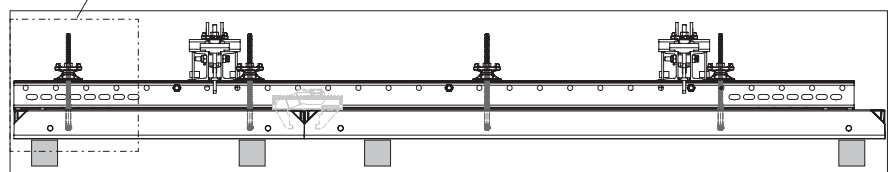
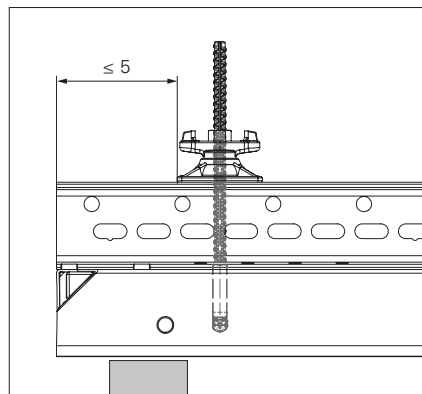

Fig. C1.01a

C1 Pre-assembling the formwork

2. Place the Strongback SRU (25) on the walers (32) according to the plan.
3. Clamp the strongback to the upper waler (32) with Waler Fixation SRU (26). (Fig. C1.01b + C1.01c)
4. Pull the outer Height Adjustment Unit SRU (27.1) over the lower end of the strongback.
5. If Crossbeam Head RCS/VARIO is used: Fit the strongback adapter (35) onto the strongback with filler pin \varnothing 21 (15) and cotter pin 4/1 (16).
6. Position the upper section of the height adjustment unit (27.1) and mount it in the strongback with filler pin \varnothing 21 (15a) and cotter pin 4/1 (16a).
7. Spindle the lower section (27.2) of the adjusting screw AF 30 (27.3) until it makes contact with the waler.
- The waler is now resting on the stringers of the height adjustment unit on both sides.
8. Fine-tune the strongback position.



Maximum formwork weight per Height Adjustment Unit SRU: 1,200 kg.

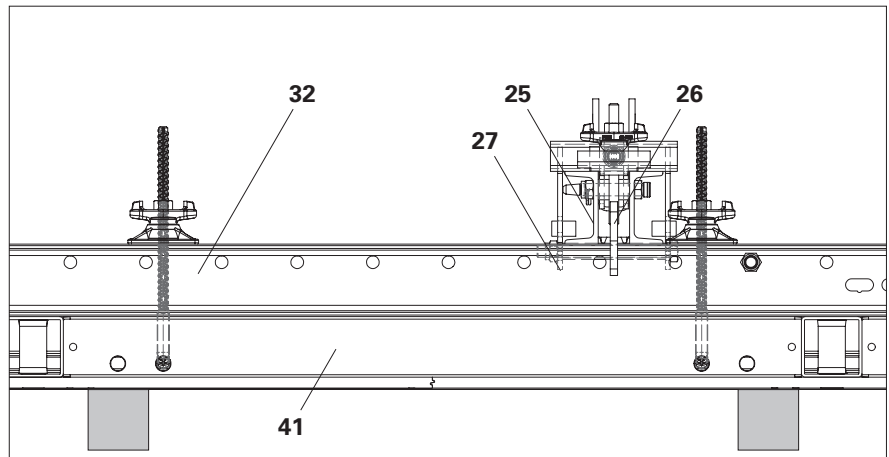

Fig. C1.01b

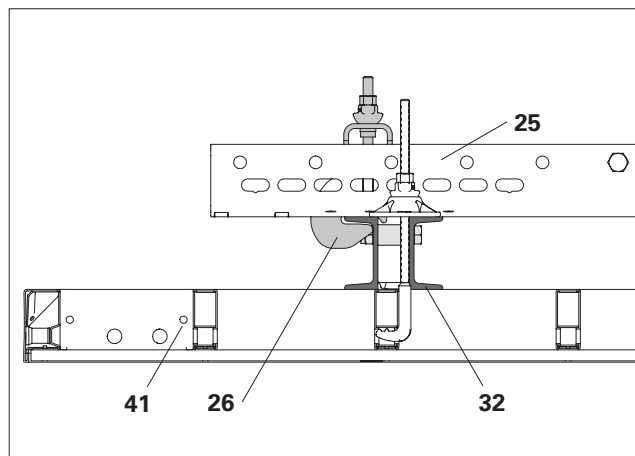

Fig. C1.01c

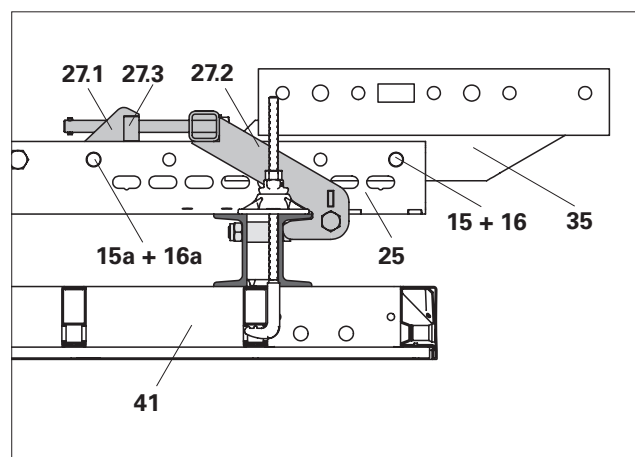

Fig. C1.01d



The Strongback Adapter RCS/SRU enables TRIO Formwork Panels to be mounted on Crossbeam Unit RCS 220 VARIO.

Strongback with Formwork Waler 150 CB



Position the U-profile of the Formwork Waler 150 CB upwards or downwards depending on the attachments required.
e.g. upwards for waler fixation (26), downwards for height adjustment unit-2 (27).

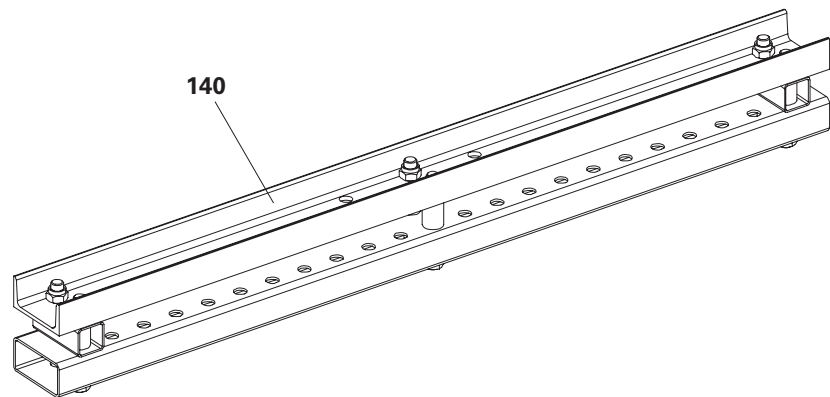

Fig. C1.02

Components

- 25** Steel Waler Universal
SRU L = 2.72
 - 26** Waler Fixation U100 – U120
 - 27** Height Adjustment Unit-2
CB/SCS/RCS
 - 140** Formwork Waler 150 CB
 - 142** Clamp Adapter MX/TR-SRU
- For alternative assembly process:
- 15** Filler pin Ø 21 x 120
 - 16** Cotter pin 4/1



- Project-specific planning and dimensioning is required!
- The Formwork Waler 150 CB (110) is attached to the Clamp Adapter MX/TR – SRU (142) as standard by means of the Tie Rod DW 15 (142.3) and Wingnut Counterplate DW 15 (142.4). (Fig. C1.04a)
If the Wingnut Counterplate DW 15 (142.4) collides with the strongback, the Clamp Adapter MX/TR – SRU (142) can be fitted using filler pins Ø 21 x 120 (15) and cotter pins 4/1 (16). (Fig. C1.03)
- Assembly on the Strongback SCS 325 and 550 takes place in the same way.

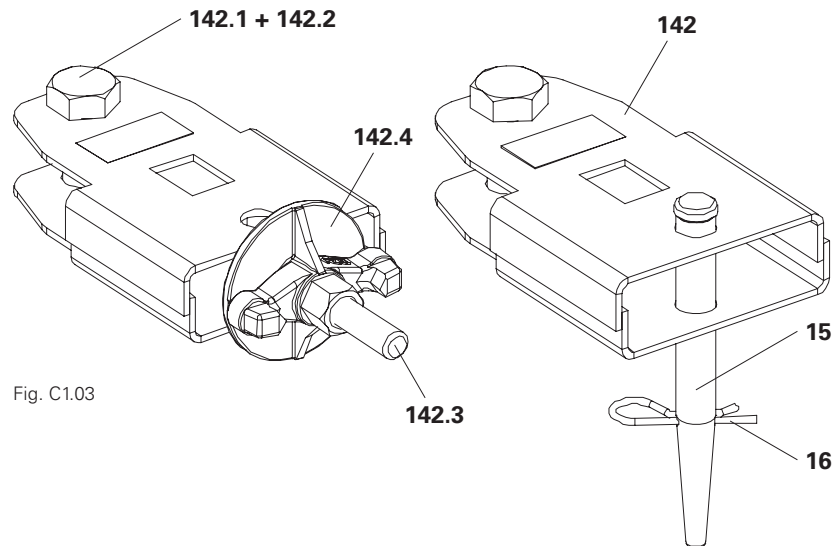

Fig. C1.03

Assembly of Formwork Waler 150 CB on the TRIO Panel

1. Assemble TRIO Panels on the assembly area to create formwork units.
2. Fit 2x Clamp Adapter MX/TR-SRU (**142**) onto the formwork using bolt ISO 4014 M24 x 80-8.8 (**142.1**) and nuts ISO 4032 M24-8 (**142.2**). (Fig. C1.04)
3. Place the Formwork Waler 150 CB (**110**) with U-profile pointing upwards on the Clamp Adapter MX/TR-SRU (**142**).
4. Brace the Formwork Waler 150 CB (**110**) on the formwork using Tie Rod DW 15 (**142.3**) and Wingnut Counterplate DW 15 (**142.4**). (Fig. C1.04a)

Alternatively:

Mount the Formwork Waler 150 CB on the Clamp Adapter MX /TR-SRU using filler pins $\varnothing 21 \times 120$ (**15**) and cotter pins 4/1 (**16**).

5. Position the strongback (**25**) on Formwork Waler 150 CB (**110**) according to the bracket spacing. For the bottom projecting length, see the project-specific planning.
6. Mount Waler Fixation U100 – U120 (**26**) and secure in position by tightening the quick jack nut. (Fig. C1.05 + C1.05a)

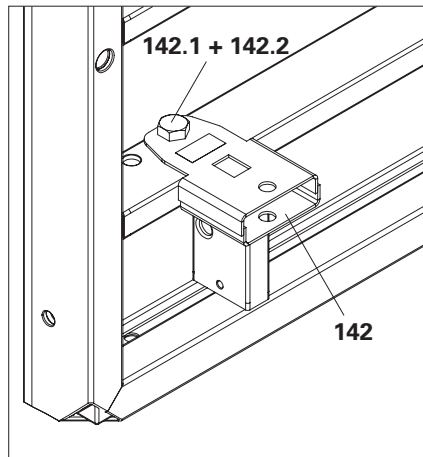

Fig. C1.04

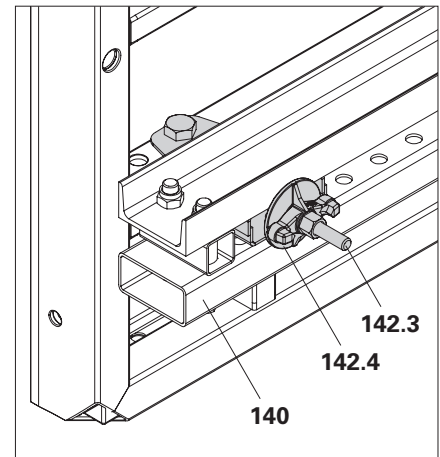

Fig. C1.04a

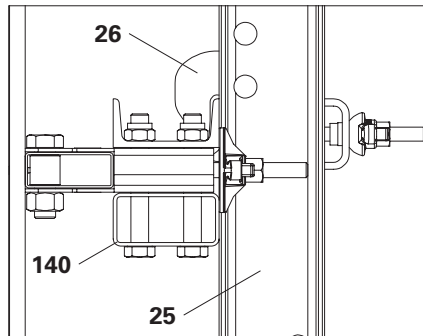

Fig. C1.05

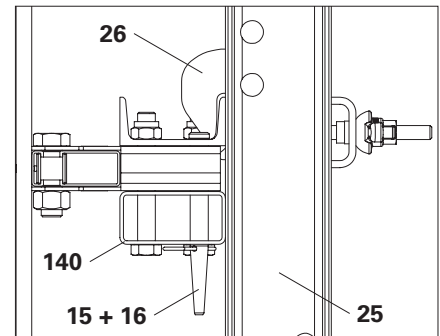

Fig. C1.05a



Does the Formwork Waler 150 CB rest against the vertical profiles of the formwork?

Strongback on VARIO formwork

Components

- 15 Filler pin Ø 21 x 120
- 16 Cotter pin 4/1
- 25 Steel Waler Universal SRU
- 26 Waler Fixation SRU
- 27 Height Adjustment Unit SRU
- 32 Waler

Assembly

Assembly takes place on horizontally-positioned element

1. Position the strongback on the walers of the formwork according to the planning specifications.
2. Fix the Strongback SRU U120 (25) to the upper waler (32) with Waler Fixations SRU (26). (Fig. C1.07a)
3. Pull the outer Height Adjustment Unit SRU (27) over the lower end of the strongback.
4. Fit the upper section of the height adjustment unit into the strongback using filler pins Ø21 (15) and cotter pins 4/1 (16).
5. Spindle the lower section of the adjusting screw AF 30 until it makes contact with the waler. (Fig. C1.07b)
→ The waler is now resting on the stringers of the height adjustment unit on both sides.
6. Fine-tune the strongback position.
7. Tighten the Waler Fixation SRU (26).



Maximum formwork weight per Height Adjustment Unit SRU: 1,200 kg.

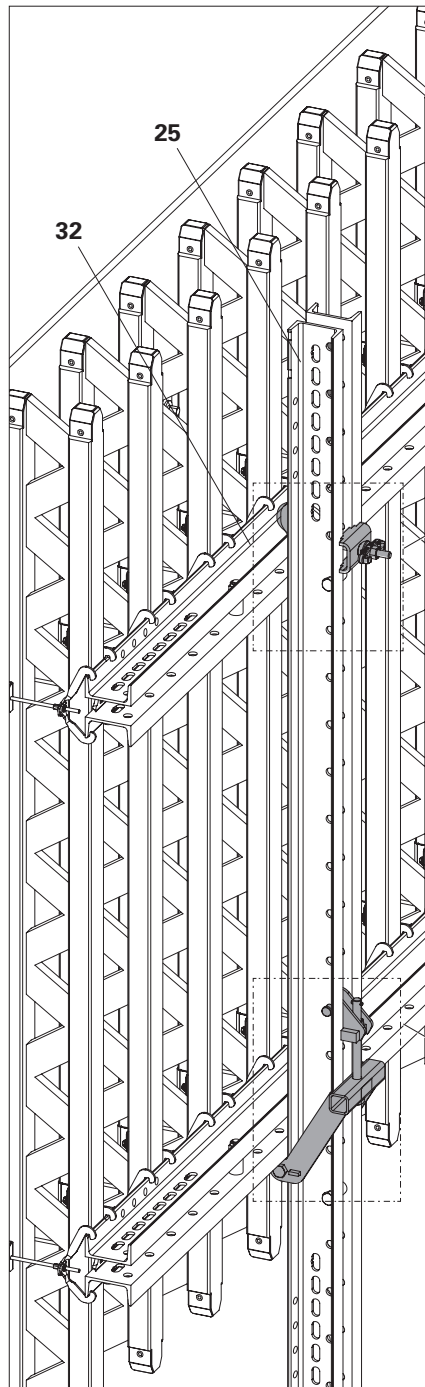

Fig. C1.07

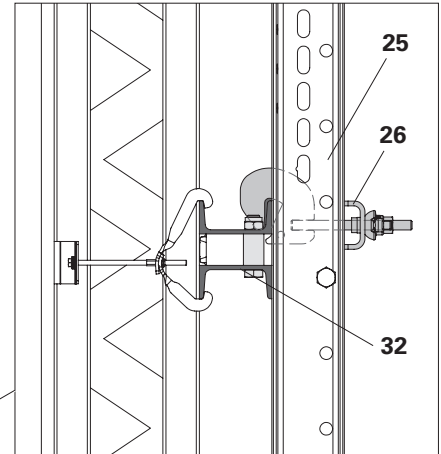

Fig. C1.07a

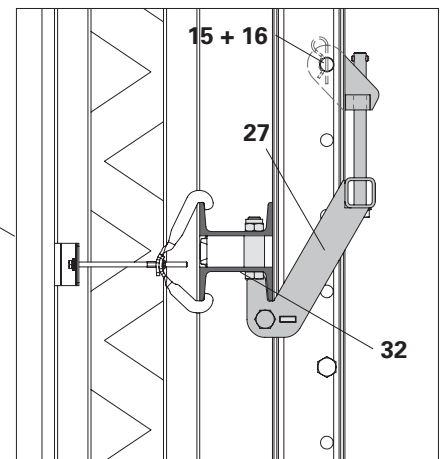

Fig. C1.07b

Concreting platform

Concreting platform with individual brackets

Install the concreting platform according to project-specific planning:

Use the Scaffold Bracket GB 80 for VARIO.

Use the Scaffold Bracket TRG 80 for TRIO.

See the Instructions for Assembly and Use of the relevant formwork system.

1. Attach the console brackets for the concreting platform to the formwork.
2. Cover the console brackets with planks. Make recesses in the planking (**76**) at the strongbacks (**25**) and secure them at the console brackets to prevent them from shifting and lifting.

(Fig. C1.08)

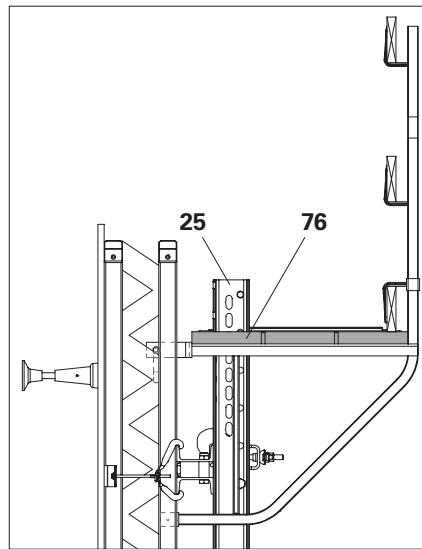

Fig. C1.08

Mounting concreting platforms on the strongback

Components

- 37** Platform Beam RCS/SRU 113
- 75** Platform beam (GT 24 here)
- 76** Planking
- 77** Toe board
- 80** Guardrail Post RCS/SRU 184
- 88** Steel scaffolding tube $\varnothing 48.3 \times 3.2$
- 125** Wood screw 6x80 SK-TX30 HPI
- 137** Hex wood screw 8 X 60 DIN 571

Assembly

Install the concreting platform according to project-specific planning. Assembly takes place on horizontally-positioned element:

1. Screw the platform beam (**75**) onto each vertical connection of the Platform Beam RCS/SRU 113 (**37**) with 2x wood screws $\varnothing 8 \times 60$ (**137**).
2. Cut the planking (**76**) to size. Make recesses in the planking in the area of the strongbacks. Screw the planks onto each platform beam with 2x wood screws 6x80 SKTX30 HPI (**125**).
3. Screw toe boards (**77**) to the planking with squared timber angle connectors at intervals of approx. 1 m. See Section "Toe boards" on page 42.
4. Screw the Guardrail Post RCS/SRU (**80**) to the concreting platform with the 2x hex. bolts M20 x 100 (**80.1**) and nuts supplied. (Fig. C1.09)
5. Attach the concreting platform on the platform beam to the crane and transport it to the formwork. (Fig. C1.10)

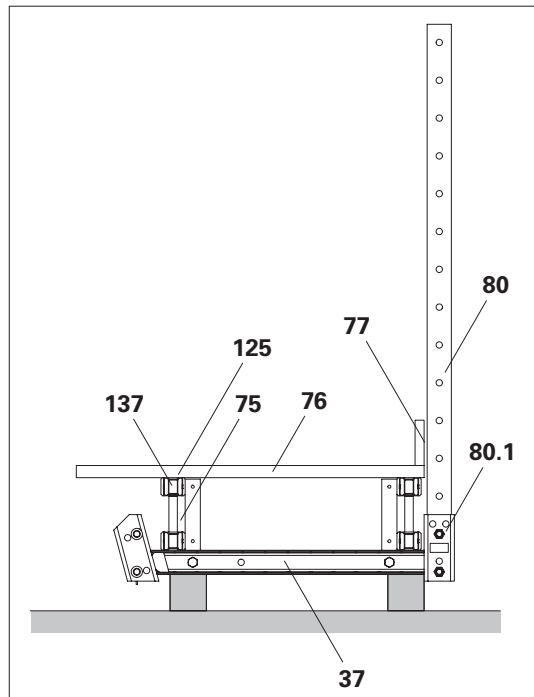

Fig. C1.09

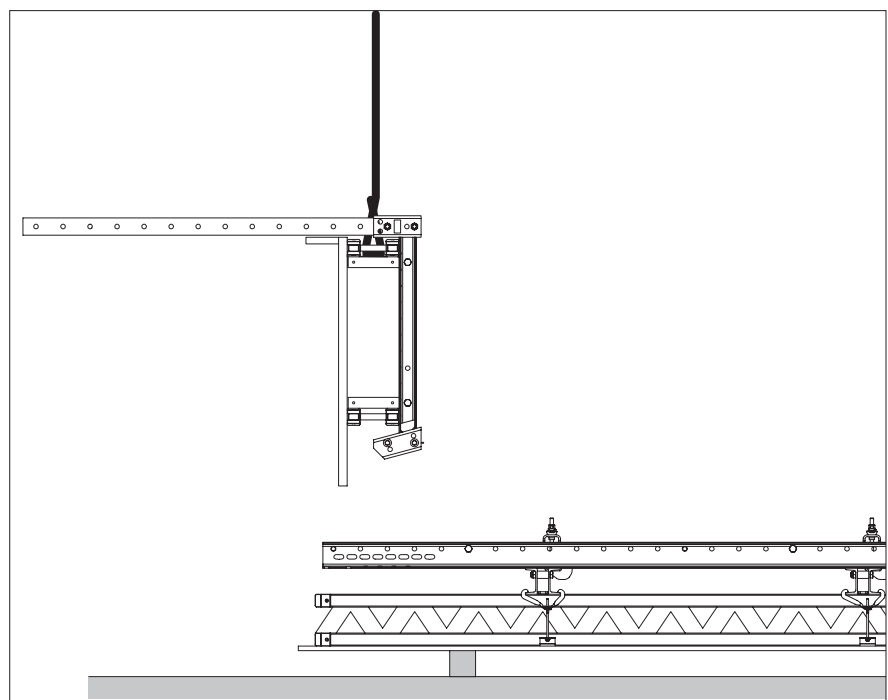

Fig. C1.10

C1 Pre-assembling the formwork

6. Mount the pre-assembled platform on the strongback (25) with the 2x filler pins $\varnothing 21 \times 120$ (37.1), washer and cotter pin 5/1 supplied.
7. Attach the strongback to the crane and rotate the formwork. (Fig. C1.11)
8. Fit the scaffolding tubes (88) or guardrail boards to the guardrail post. See Section "Guardrails" on page 52. (Fig. C1.12)
9. Spray the formlining with concrete release agent. Protect platform planking from release agent.

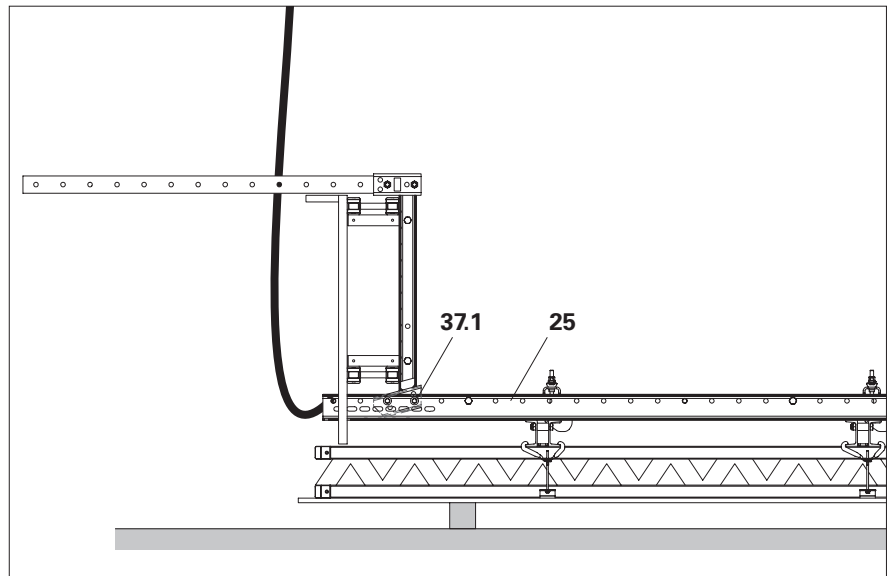

Fig. C1.11

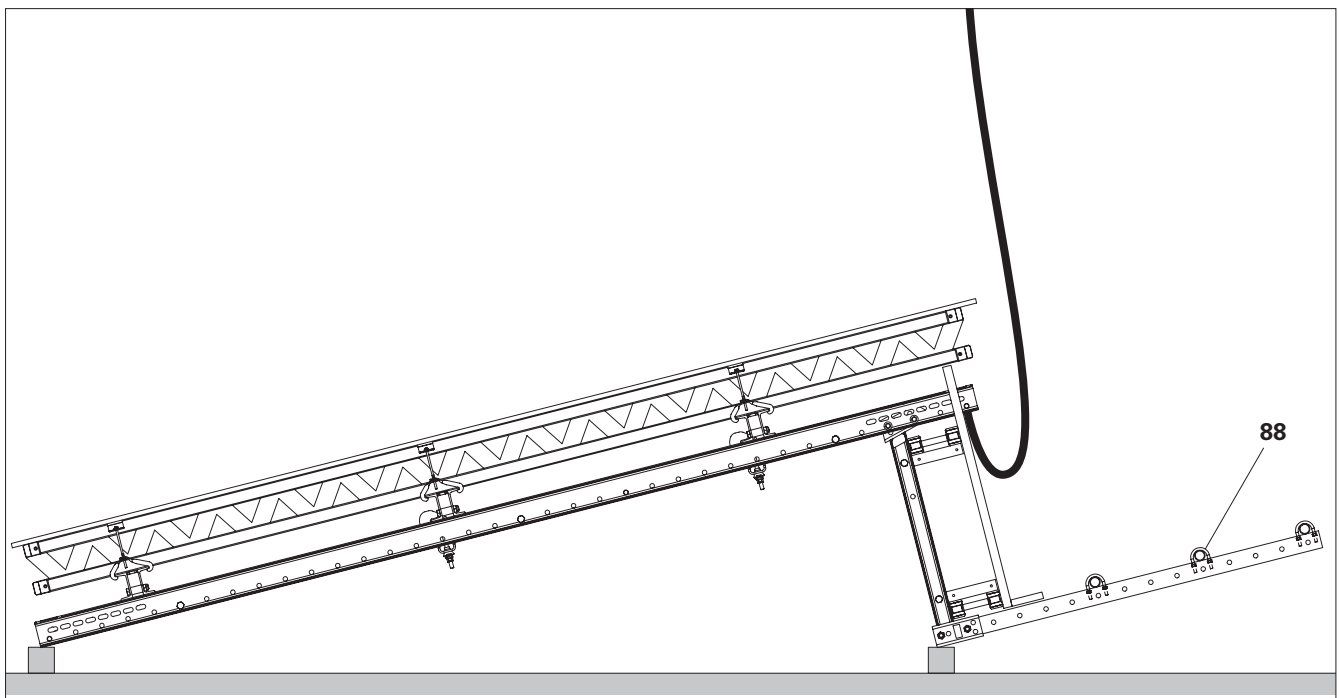

Fig. C1.12

Fitting the intermediate platforms onto the strongback

Components

- 37** Platform Beam RCS/SRU 113
- 81** Guardrail Post U100 384 RCS
- 137** Hex wood screw 8 X 60 DIN 571

1. For intermediate platforms, pre-assemble Platform Beam RCS/SRU (**37**) in the same way as the concreting platform.
2. Screw the shared Guardrail Post RCS 384 (**81**) to the concreting and intermediate platform using the 2x hex. bolts M20 x 100 (**81.1**) and nuts supplied.
3. Attach the strongback to the crane and rotate the formwork.
4. Attach the scaffolding tubes or guardrail boards to the guardrail post. See Section "Guardrails" on page 52.
5. Spray the formlining with concrete release agent. Protect platform planking from release agent.



To fit an access ladder, see the separate product information.

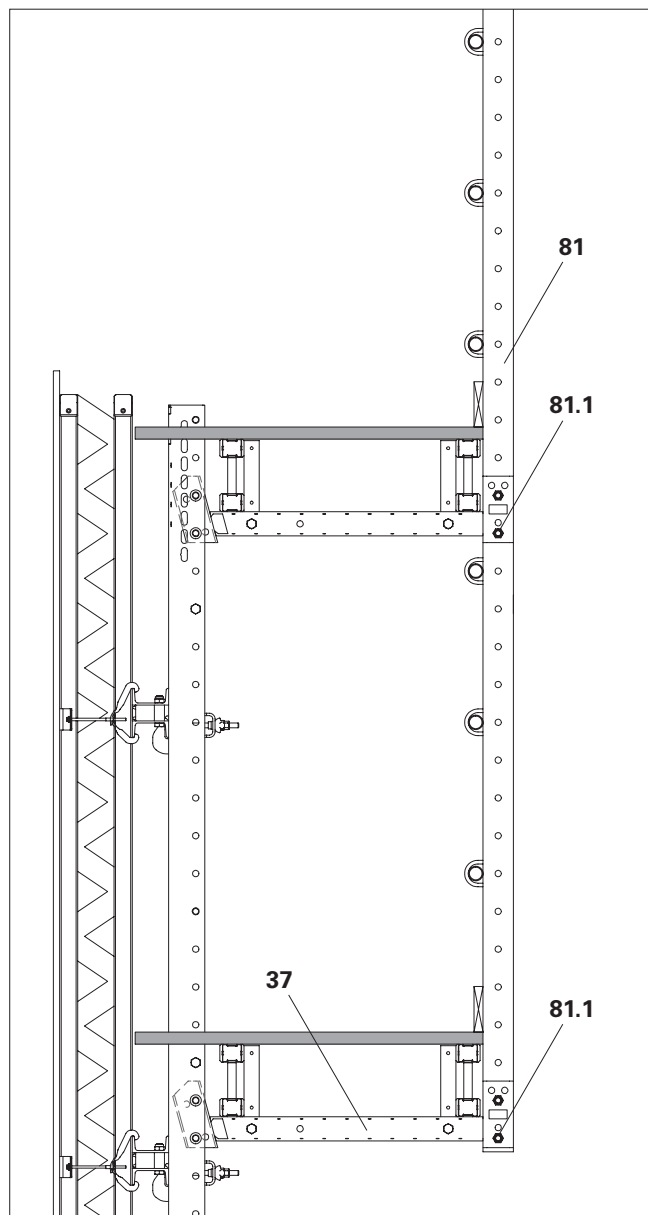

Fig. C1.13

Mounting the work platform



- For assembly, a crane or other lifting device as well as a level assembly surface are required.
- Secure intermediate posts with temporary supports to prevent tipping over.
- Aligned and calibrated stops simplify the process of pre-assembling the console brackets in a precise and quick manner.

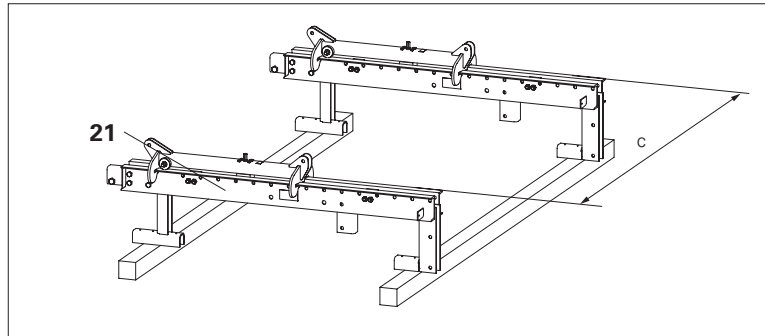

Fig. C2.01

Assembling the platform

Components

- 21** Crossbeam Unit RCS 220 VARIO
- 22** Crossbeam Head RCS/VARIO
- 24** Carriage RCS
- 75** Girder GT 24, e.g. 450

Assembly

1. Measure and align the crossbeam unit (**21**) on squared timbers. (Fig. C2.01)
2. Pre-drill the platform beams, in this case, GT 24 (**75**), with $\varnothing 8$ mm holes according to the drilling plan. (Fig. C2.02a)
3. Insert the platform beam into the crossbeam according to the plan and screw it tight with F.H. Bolts M8, see Section "B2 Planning the platforms" on page 38. (Fig. C2.02)

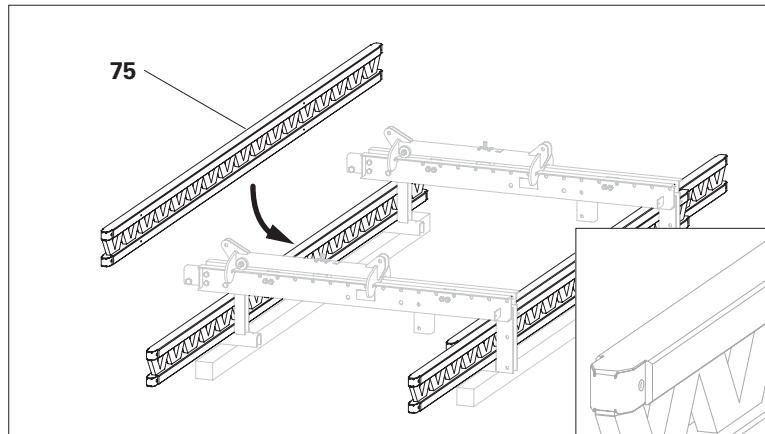

Fig. C2.02

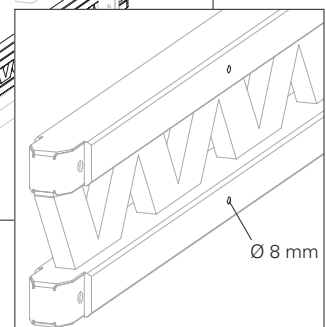

Fig. C2.02a

4. Screw the planking, diagonal bracing and multi-layer plywood sheets to the platform beams according to the plan, see Section "Planking" on page 42.
5. Fit the toe boards with squared timber angle connectors, see Section "Toe boards" on page 42. (Fig. C2.03)

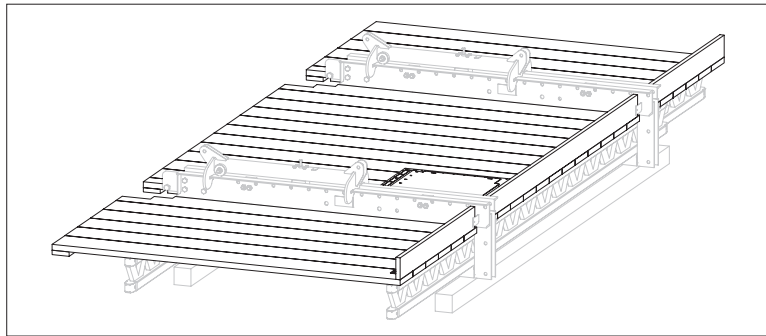

Fig. C2.03

Opening for hinged hatch

Make a recess of 57 x 72 cm in the deck. The position must be determined on a project-specific basis. Screw an additional support 120/40 mm, to the side of the end-to-end planks with at least 4x F.H. bolts DIN 603 M8 x 125 (**114**) + washers A8 ISO 7093 (**120**). Bore \varnothing 8 mm.

Fitting the hatch

1. Place Hatch RCS 55 x 60-2, foldable (**66**) in the prepared recess. The opening direction of the hatch cover must be determined on a project-specific basis.
2. Screw the frame of the hatch and the planking together with approx. 16x wood screws 6x40 SK-TX30 HPI (**127**).

(Fig. C2.03 + C2.03a)

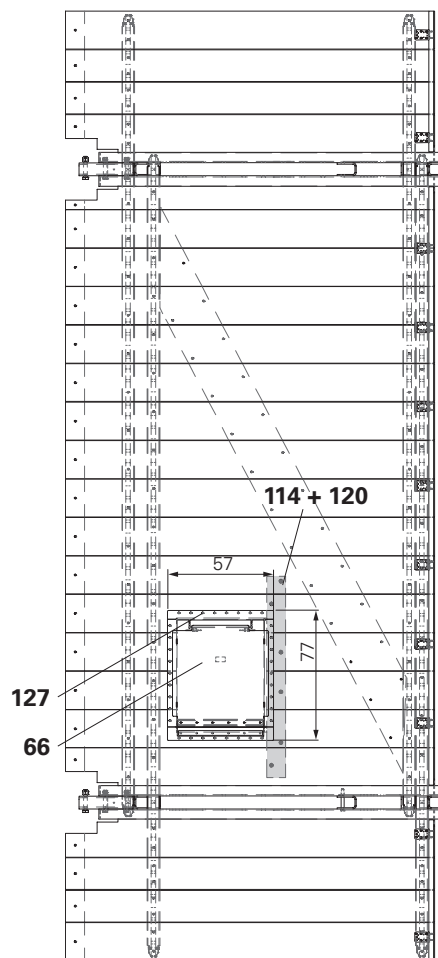

Fig. C2.03a

Installing the lateral protection

Components

- 79** Guardrail Post RCS 226
- 79.1** Bolt ISO 4014-M20 x 120-8.8
- 89** Clamp A64 DIN 3570

Assembly

1. Screw Guardrail Post RCS 226 (**79**) in place with 2x screws M20 x 120 (**79.1**) and nuts. Use the two upper holes. The lower hole must remain free for fitting the bottom ladder cage.
2. Screw the scaffolding tubes \varnothing 48 to the guardrail post with clamp A64 (**89**), see Section "Guardrails" on page 52. (Fig. C2.04)
3. Fit the lateral guardrail, see Section "Lateral guardrails" on page 54.

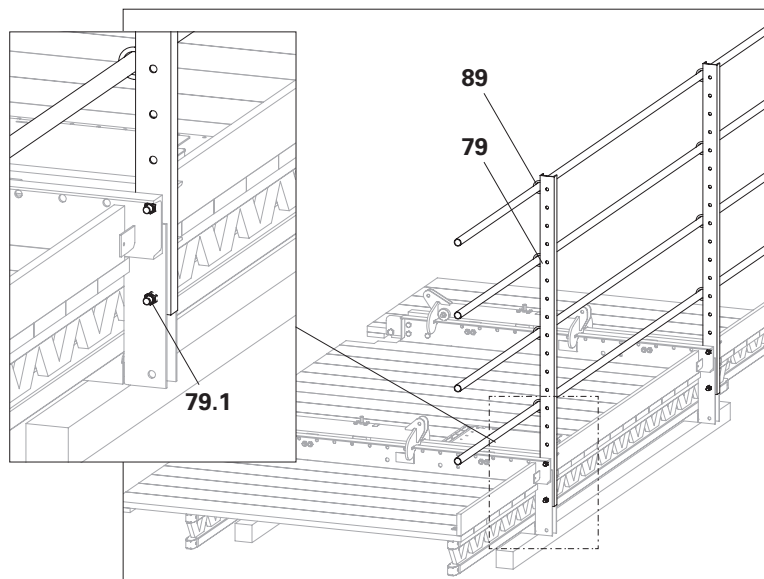

Fig. C2.04

Preparing the climbing rail

Components

- 1** Upper Climbing Rail RCS
- 87** Scaffolding tube bracing
- 91** Scaffold Tube Holder LPS/
RCS D = 48
- 97** Swivel Coupling AF 48/48

Assembly

1. Measure and align upper climbing rails (**1**) on squared timbers based on the project-specific climbing rail spacing (c).
2. Connect climbing rails with scaffolding tubes and scaffold tube holders \varnothing 48 (**91**).
3. Connect scaffolding tube diagonally with swivel couplings (**97**).
4. Fit a 15-cm-thick squared timber at the lower end of the climbing rails as a spacer to the structure. (Fig. C2.05)

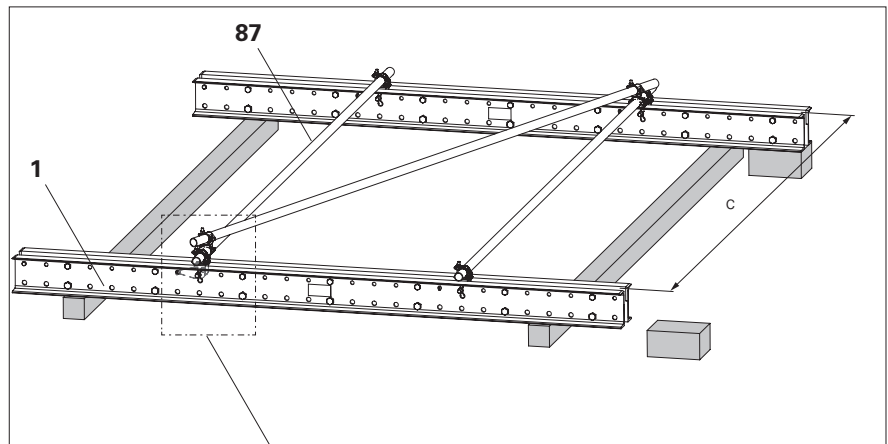
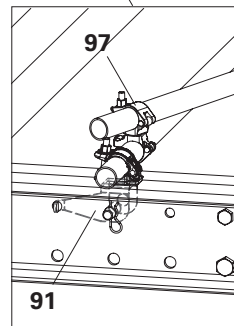

Fig. C2.05



Fitting the spacer M20

In some cases, it may be necessary to fit a spacer M20-82 (**3**) as a climbing bolt in the climbing rail, see Section "Additional spacers" on page 35.

Components

- 3** Spacer M20-82
- 3.1** Spacer tube $\text{\O} 26.9 \times 2.6 \dots 82$
- 3.2** Bolt ISO 4014 M20 $\times 120$ -8.8
- 3.3** Nut ISO 7042 M20-8

Assembly

1. Position spacer tube $\text{\O} 26$ (**3.1**) of the spacer M20 (**3**) in the Climbing Rail RCS with the help of a hammer.
2. Insert bolt M20 $\times 120$ (**3.2**) through the holes $\text{\O} 21$ of the climbing rail and through the spacer tube.
3. Attach self-locking nut M20-8 (**3.3**) (AF 30) to the bolt and tighten. Tightening torque min. 100 Nm. (Fig. C2.06)

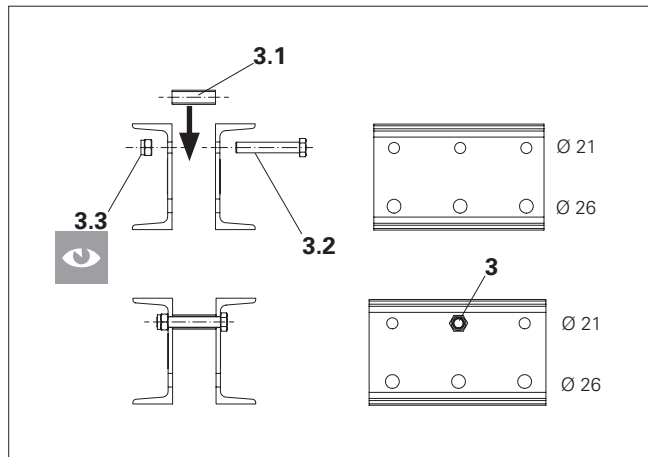

Fig. C2.06



Has the nut (**3.3**) been tightened?
(Fig. C2.06)



- Spacers M20 (climbing bolts) must **not be moved** within the climbing rail, but installed in addition. The stroke of the climbing device allows a maximum distance of 50 cm from the spacers.
- It may be necessary to release adjacent spacers in the climbing rail. After mounting the additional spacer, re-tighten all previously loosened bolts. Tightening torque min. 100 Nm.

Re-positioning spacer M24

In some cases, it may be necessary to move spacers M24 within the climbing rail.

Components

- 4** Spacer M24-82
- 4.1** Spacer tube $\text{Ø } 33.7 \times 4...82$
- 4.2** Bolt ISO 4014 M24 $\times 130$ -8.8
- 4.3** Nut ISO 7042 M24-8

Assembly

1. Remove nut M24-8 (**4.3**) (AF 36).
2. Remove bolt M24 $\times 130$ (**4.2**).
3. Re-position the spacer tube $\text{Ø } 33.7$ (**4.1**) of the spacer M24 with the help of a hammer.
4. Insert bolt M24 $\times 130$ (**4.2**) through the holes $\text{Ø } 26$ of the climbing rail and through the spacer tube.
5. Attach self-locking nut M24-8 (AF36) to the bolt and tighten. Tightening torque min. 150 Nm.

(Fig. C2.07)

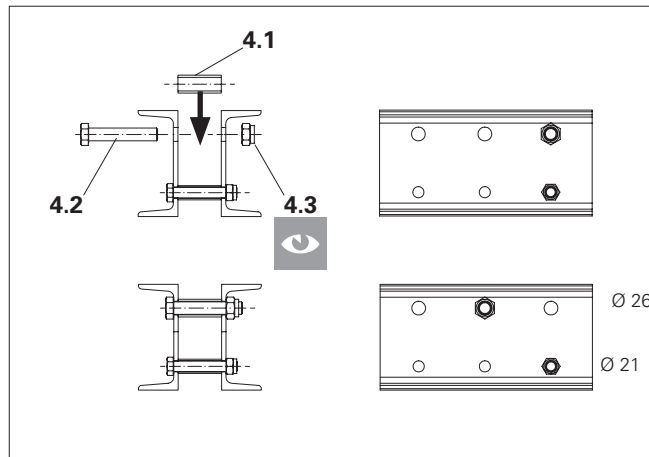

Fig. C2.07



Has the nut (**4.3**) been tightened?
(Fig. C2.07)



It may be necessary to release adjacent spacers in the climbing rail. After mounting the additional or repositioned spacer, re-tighten all previously loosened bolts. Tightening torque min. 150 Nm.

General information



Warning

- Risk of falling from unsecured building edges!
A fall can result in serious injury or even death.
⇒ Install guardrails.
⇒ Use personal protective equipment to prevent falling from a height (PPE).
- During assembly on the construction site, components may fall to the ground and hit people below!
This can lead to serious injuries or even death.
⇒ Cordon off danger zones beneath the working areas.
⇒ Release the climbing unit from the crane lifting gear only when all climbing shoes are closed and the climbing unit is resting fully on the climbing shoes.



- Before attaching the RCS units, check the structure for sufficient load-bearing capacity.
- A pre-requisite of the assembly procedure is that work is carried out for a short period of time with the load attached in a positive-locking manner.

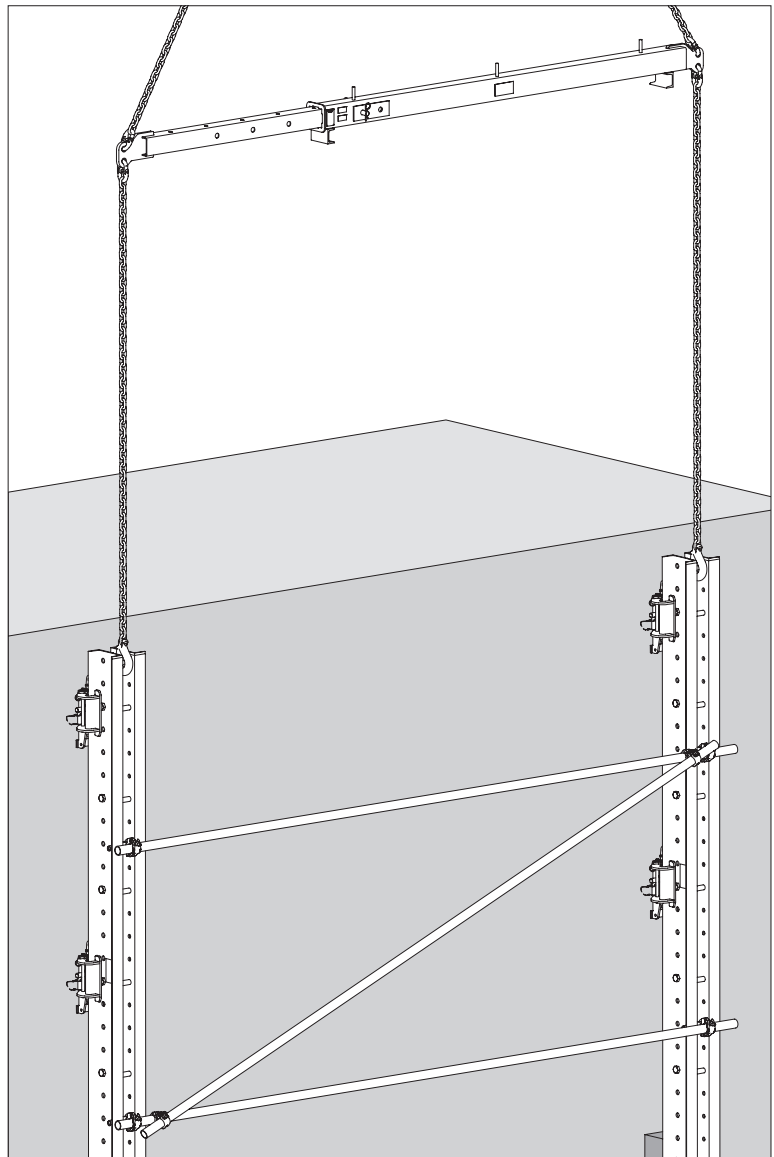

Fig. C3.01

Attaching the climbing rail

Components

- 3** Spacer M20-82
- 10** Climbing beam 9 t
- 47** Anchoring
- 50** Climbing Shoe RCS
- 51** Wall Shoe RCS

Assembly

1. Fit the Wall Shoes RCS (**51**) onto the anchoring (**47**) set in concrete.
 2. Fit the Climbing Shoes RCS (**50**) onto the wall shoes with the corresponding locking pin.
 3. Activate the climbing pawls.
 4. Attach climbing rails with climbing beam (**10**) to the uppermost spacer or Lifting Eye BR-2 2.5 t.
 5. Insert the climbing rails into the opened climbing shoes and close them from a safe position.
 6. Place the climbing rail with planned spacer (**3**) on the climbing pawl (**50.1**).
 7. Check that the squared timber is securely seated in its role as a spacer to the structure.
 8. From a safe position, knock off the crane lifting gear.
- (Fig. C3.02)

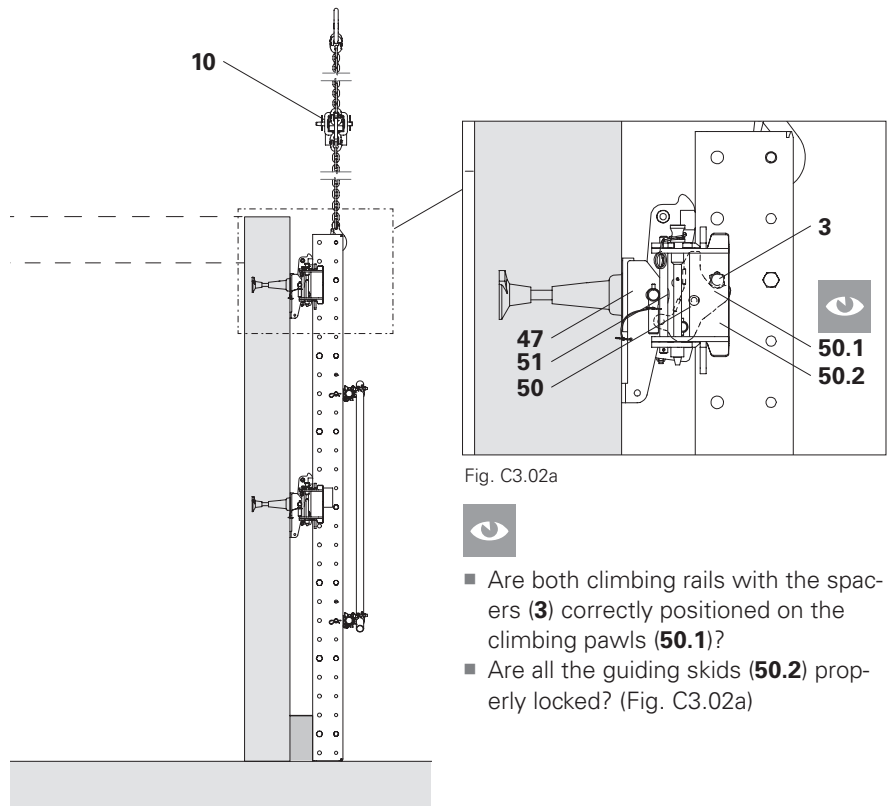

Fig. C3.02

Fig. C3.02a



- Are both climbing rails with the spacers (**3**) correctly positioned on the climbing pawls (**50.1**)?
- Are all the guiding skids (**50.2**) properly locked? (Fig. C3.02a)



- For assembly of the wall and climbing shoes, see Section "Fitting the suspension" on page 106.
- For operation of the climbing shoes, see Section "D5 Operating the climbing shoe" on page 110.

Mounting the work platform

Components

- 6** Climbing rail extension RCS 100
- 11** Diagonal strut I = 2121
- 21** Crossbeam Unit RCS 220 VARIO
- 22** Crossbeam Head RCS/VARIO
- 108** Bolt ISO 4014-M24 x 130-8.8

Assembly

1. Attach the work platform to the crane with the four-sling lifting gear.
Attachment points: 1 filler pin $\varnothing 21 \times 120$ with cotter pin 4/1 at both the front and back of the carriage.
2. When transporting by crane, guide the work platform with ropes from a safe position.
3. Fix the crossbeam (**21**) with Crossbeam Head RCS/VARIO (**22**) to the climbing rail by fitting a screw M24 x 130-8.8 (**108**) in the 4th hole $\varnothing 26$. (Fig. C3.03a)
4. Fit the diagonal struts (**11**) with 2x bolts (**11.1**) and 4x cotter pins (**11.2**).
5. Screw the climbing rail extension (**6**) to the crossbeam unit with the M24 x 130 bolt and nut supplied.

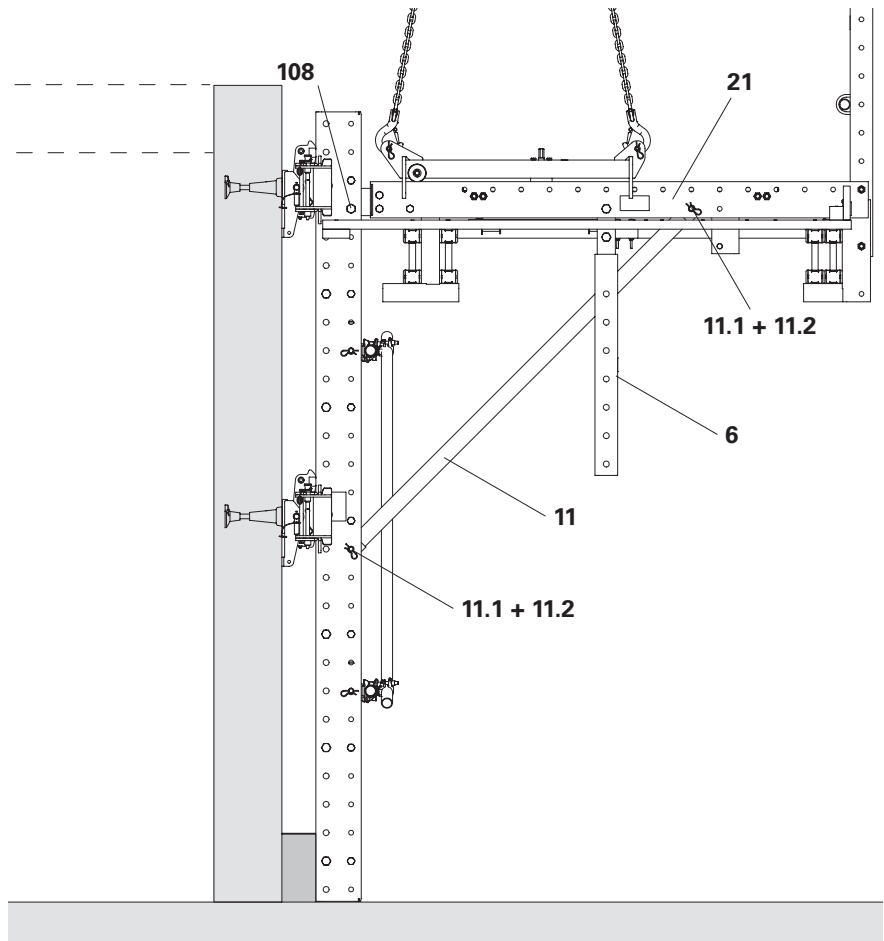

Fig. C3.03



It may be necessary to move spacers or to loosen adjacent spacers in the climbing rail for installation. See Section "Preparing the climbing rails" on page 87.

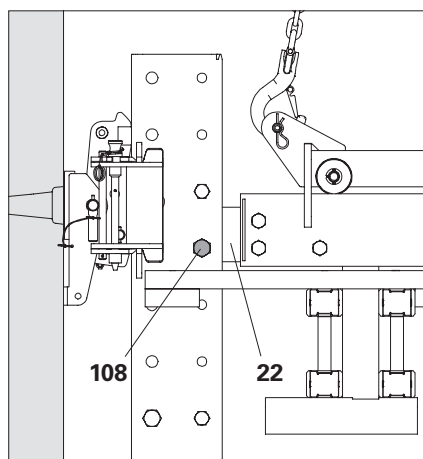

Fig. C3.03a

Fitting formwork

Components

- 15 Filler pin \varnothing 21 x 120
- 16 Cotter pin 4/1
- 24 Carriage RCS
- 25 Steel Waler Universal SRU L = 2.72
- 28 Heavy Duty Spindle SLS 200/300
- 47 Anchoring

Requirements

The climbing rail must be braced against the structure at the lower end using squared timber (thickness 15 cm). Alternatively, a Climbing Rail Joint RCS can be used.

Assembly

1. Fit a formwork spindle (28) onto the strongback (25) with a filler pin and cotter pin. The installation position must be determined on a project-specific basis.
2. Attach pre-assembled formwork elements to the strongback (25).
3. Set up the formwork and move it to the bracket unit. (Fig. C3.04)

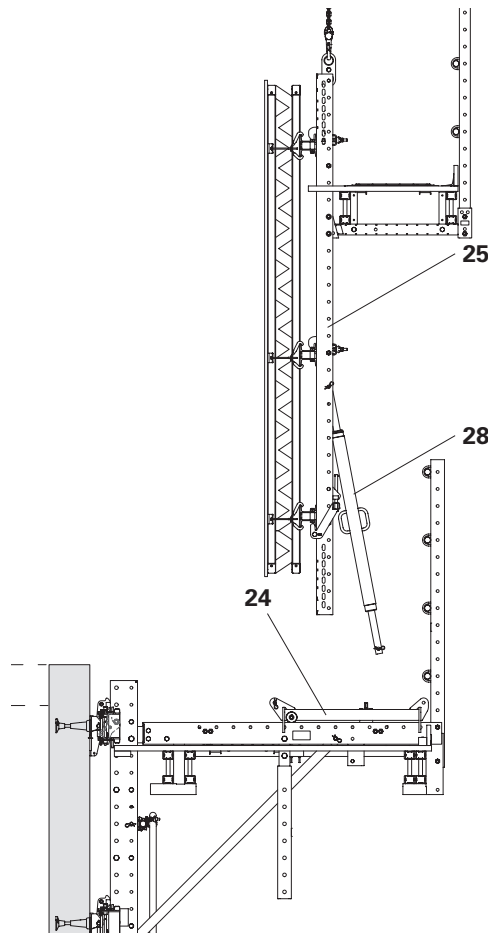

Fig. C3.04

4. Fit the strongback (25) onto the carriage (24.1) with 1 filler pin \varnothing 21 x 120 (15) and cotter pin 4/1 (16). The crane continues to carry the load.
5. Fit the formwork spindle onto the carriage (24.2) with filler pin and cotter pin.
6. Release crane from all loads and remove crane lifting gear.
7. Fit the leading tie (47). (Fig. C3.05)

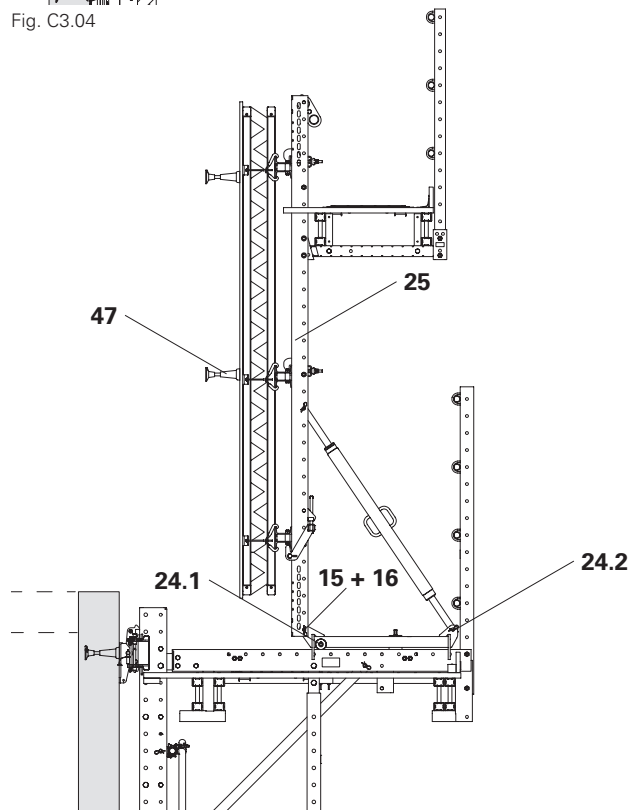

Fig. C3.05

Fitting the leading tie

Preparation

Measure out the position of the leading tie and mark on the formwork surface.

Standard: Positioning screw



- Ensure there is sufficient distance to the formwork girder. (Fig. C3.06a)
- If the distance is insufficient, the anchor positioning stud must be used.
- Check all tie components, assembly and position before concreting takes place.
- Before striking the formwork, always loosen the positioning screws first!

Components per climbing tie

- 475** Climbing Cone-2 M30/DW 20
- 476** Tie Rod DW 20
- 472** Threaded Anchor Plate DW 20
- 42.1** Positioning Screw M30
- 42.3** Anchor Positioning Plate M30 1x
- 135** Hex. wood screw DIN 571 6 x 20

Assembly

1. Drill a suitable hole in the formlining. (M30 = bore Ø 32 mm)
2. Attach Anchor Positioning Plate M30 (**42.3**) to the rear side of the formlining matching the drilled hole using 4x hex. wood screws DIN 571 6 x 20 (**135**).
3. Insert the Positioning Screw M30 (**42.1**) from the rear side through the drilled hole.
4. Screw the Climbing Cone-2 M30/DW 20 (**475**) from the front side on the Positioning Screw M30 (**42.1**).
5. Screw Tie Rod DW 20 (**476**) onto the Climbing Cone-2 M30/DW 20 (**475**).
6. Screw the Threaded Anchor Plate DW 20 (**472**) onto the Tie Rod DW 20 (**476**).

(Fig. C3.06)



Precise alignment of the anchoring points in all 3 axes is essential if the climbing unit is to function correctly.

- Measure the anchoring points precisely (plumb line, chalk line) and fit them securely in their positions.
- To secure the position, fasten the Threaded Anchor Plate (**472**) to the reinforcement, e.g. with wire.
- To this end, tie in additional reinforcement bars both vertically and horizontally, if necessary.



To ensure that the climbing cone can be recovered later carefully grease the surfaces that are in contact with the concrete and the internal thread for the tie rod.

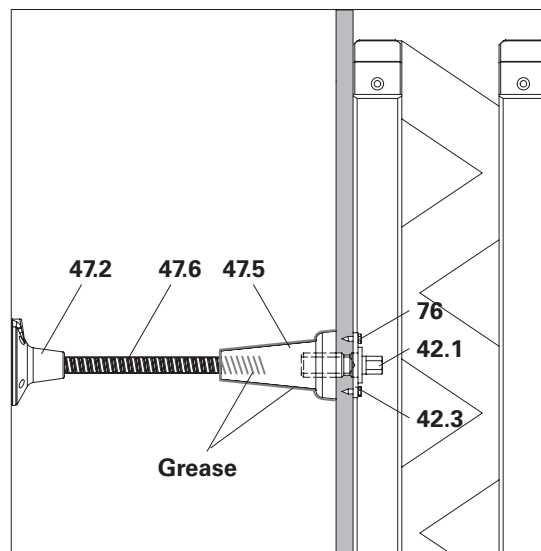

Fig. C3.06

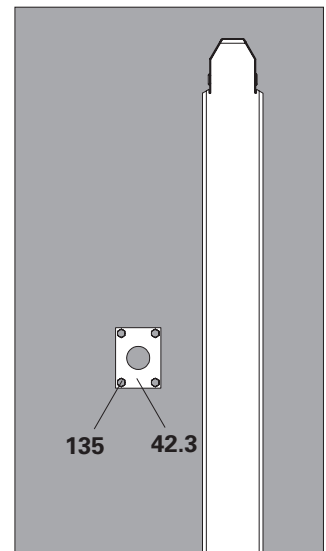

Fig. C3.06a

Alternatively: Anchor positioning stud



- Fix the Threaded Anchor Plate DW 20 (47.2) to the reinforcement with wire to secure the position.
- Check all tie components, assembly and position before concreting takes place.
- If possible, use the fixing with the positioning screw as the connection is more stable.
- When striking the formwork, the nails must be pulled through the formlining. So, do not bend the nails.

Components per climbing tie

47.1	Screw-On Cone-2 M30/DW 26	1x
47.5	Climbing Cone-2 M30/ DW 20	1x
47.6	Tie Rod DW 20	1x
47.7	Threaded Anchor Plate DW 26	1x
47.2	Threaded Anchor Plate DW 20	1x
42.2	Anchor Positioning Stud M30	1x
143	Wire nail 3 x 80	6x

Assembly

1. Nail the Anchor Positioning Stud M30 (42.2) to the front side of the formlining using 6 x wire nails 3 x 80 (143).
2. Screw Climbing Cone-2 M30/DW 20 (47.5) onto the Anchor Positioning Stud M30 (42.2).
3. Screw Tie Rod DW 20 (47.6) onto the Climbing Cone-2 M30/DW 20 (47.5).
4. Screw the Threaded Anchor Plate DW 20 (47.2) onto the Tie Rod DW 20 (47.6).

(Fig. C3.07)

Alternative

Anchoring with screw-on cone-2 (47.1) and Threaded Anchor Plate DW 26 (47.7). (Fig. C3.08)

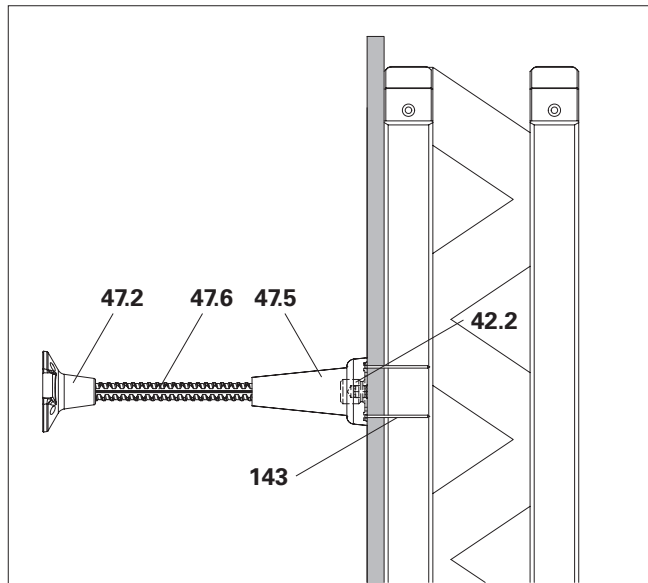

Fig. C3.07

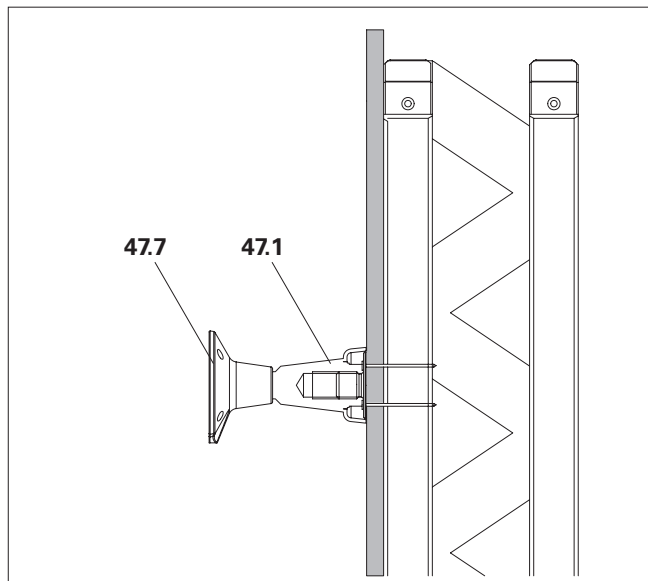

Fig. C3.08

Concreting

1. Move the carriage (24) to the concreting position.
 2. Align the formwork vertically and horizontally with the formwork spindle (28) and the Height Adjustment Unit SRU (27).
 3. Pretension the formwork moderately against the wall with the carriage.
 4. Reinforce the concreting section and pour the concrete.
- (Fig. C3.09)

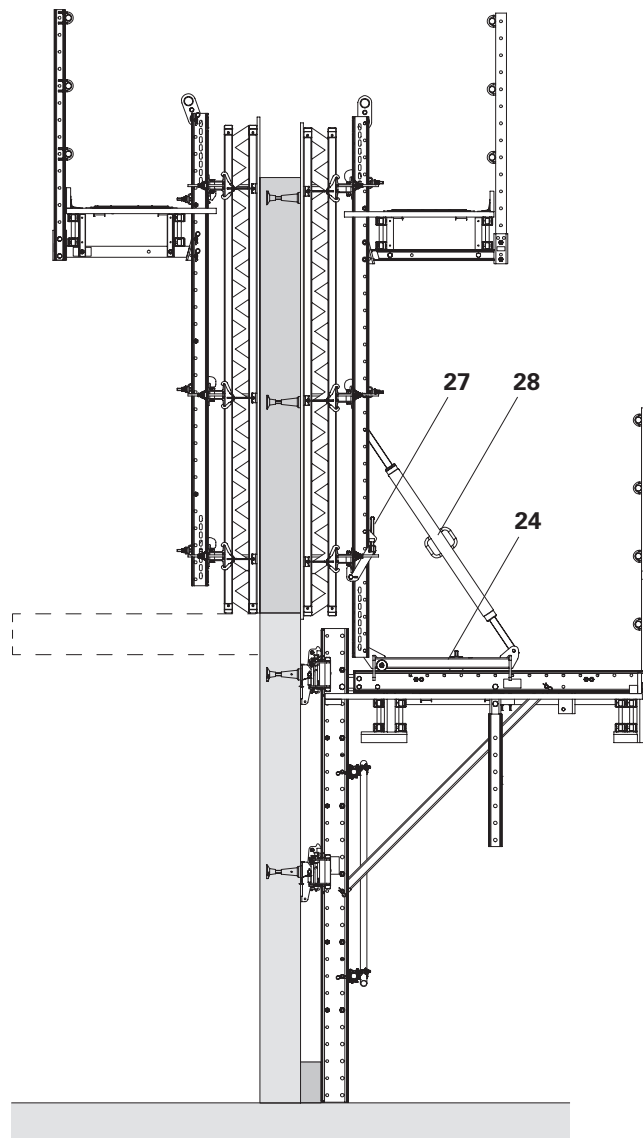

Fig. C3.09

General

For pre-assembly, there must be a sufficiently large and level assembly area available, as well as sufficient space for temporary storage.

A crane or other lifting equipment is required.

Secure intermediate posts with temporary supports to prevent tipping over.

Assembly is carried out on aligned squared timbers.

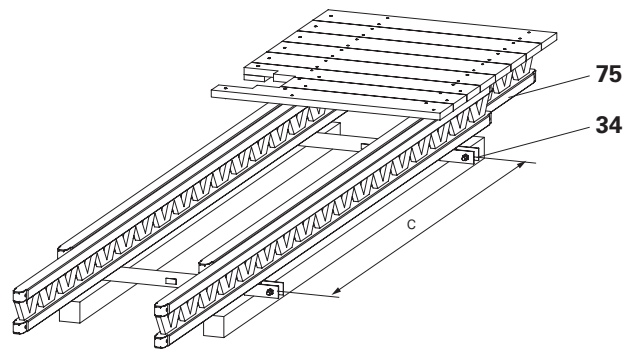

Fig. C4.01

Pre-assembling the finishing platform

Components

- 34** Finishing platform girder
- 75** Girder GT 24, e.g. 450
- 112** F.H. bolt M8 x 200 MU
- 121** Washer ISO 7089 200 HV, A8

Assembly

1. Measure and align the finishing platform beam (**34**) on squared timbers based on the project-specific climbing rail spacing (c). (Fig. C4.01)
 2. Pre-drill the platform beams, in this case, GT 24 (**75**), with $\varnothing 8$ mm holes according to the drilling plan.
 3. Place the platform beam on the finishing platform beam according to the plan and screw it tight with F.H. bolts M8, see Section "Finishing platform" on page 41.
 4. Screw the planking, diagonal bracing and multi-layer plywood sheets to the platform beams according to the plan, see Section "Planking" on page 42.
 5. Fit the toe boards with squared timber angle connectors, see Section "Toe boards" on page 42.
- The finishing platform is pre-assembled. (Fig. C4.02)

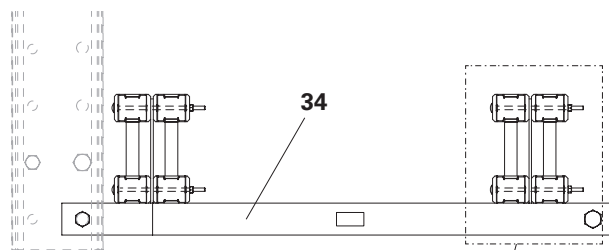

Fig. C4.01a

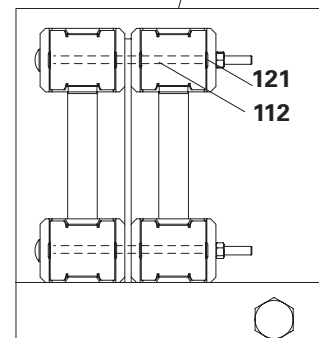

Fig. C4.01b

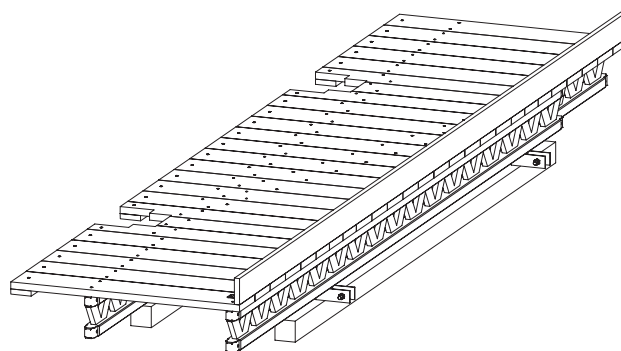

Fig. C4.02

Preparing the climbing rails

Components

- 2** Lower Climbing Rail RCS
- 5** Climbing Rail Connector RCS 73
- 17** Filler pin \varnothing 26 x 120
- 18** Cotter pin 5/1

Assembly

1. Move the M24 spacer (**4**) by one hole, see Section "C2 Pre-assembling the console bracket unit" on page 77.
2. Fit the climbing rail connector (**5**) at the upper end of the climbing rail (**2**) with 2x filler pins \varnothing 26 mm (**17**) and cotter pins 5/1 (**18**). (Fig. C4.03)

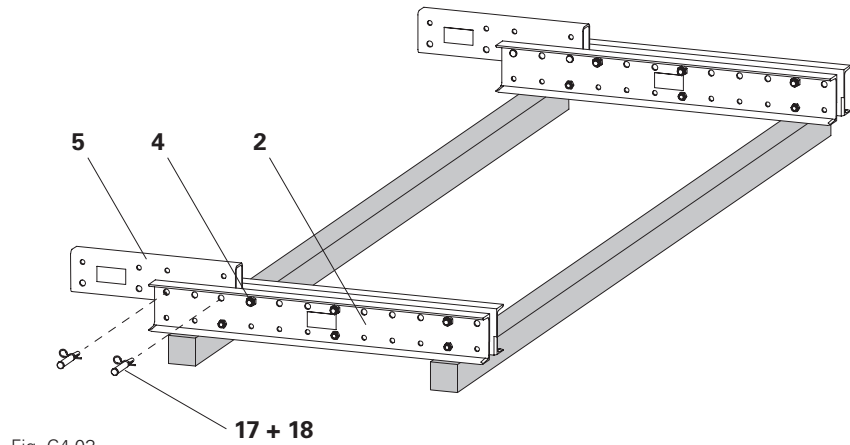

Fig. C4.03

Attaching the finishing platform

Components

- 1** Upper Climbing Rail RCS
- 2** Lower Climbing Rail RCS
- 5** Climbing Rail Connector RCS 73
- 17** Filler pin \varnothing 26 x 120
- 18** Cotter pin 5/1
- 34** Finishing platform girder
- 81** Guardrail Post 384 RCS
- 106** Bolt ISO 4014-M20 x 120-8.8
- 115** Nut ISO 7040-M20-8

Assembly

1. Mount the lower climbing rails (**2**) on the pre-assembled climbing rail connector (**5**) on the upper climbing rail (**1**) with 1 x filler pin \varnothing 26 x 120 (**17**) and cotter pin 5/1 (**18**).
2. Screw the finishing platform beam (**34**) of the pre-assembled finishing platform to the lower climbing rail using the bolt M24 x 130 (**34.1**) and nut (**34.2**) supplied, but do not tighten the bolt yet.
3. Screw Guardrail Post 384 (**81**) with the ladder cage already mounted, see Section "Guardrails" on page 52, onto the pre-mounted climbing rail extension (**6**) using 1x bolt M20 x 120 (**106**) and nut (**115**).

(Fig. C4.04)



The guardrail post has some slack in the climbing rail connector.
The M20 bolt has some slack in the hole of the climbing rail extension (\varnothing 26 mm).

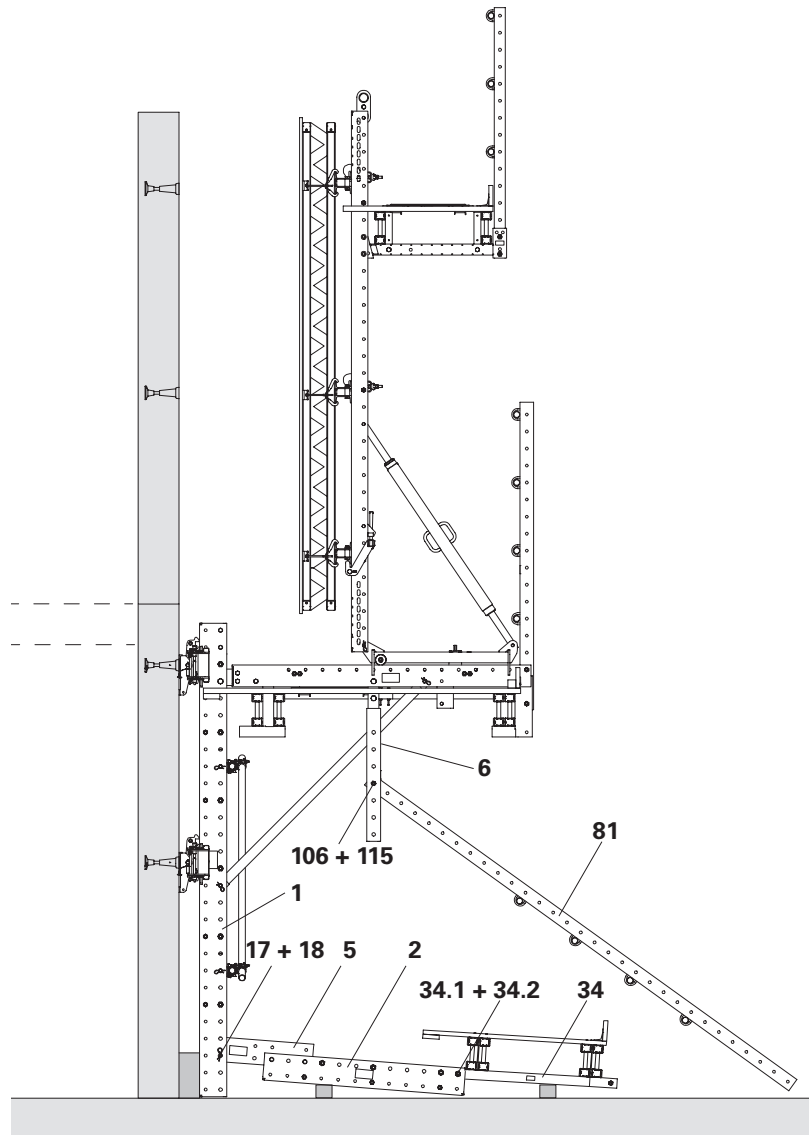

Fig. C4.04

Preparing the climbing procedure

Components

- 7 Climbing rail extension RCS 125
- 17 Filler pin Ø 26 x 120
- 18 Cotter pin 5/1
- 50 Climbing Shoe RCS
- 51 Wall Shoe RCS
- 60 Climbing Device RCS 50
- 63 Hydraulic Unit RCS 4 x 190 bar

Assembly

1. Undo formwork ties and leading tie fixings.
2. Remove the transitions and other connections between the formwork and climbing units.
3. Retract the carriage (24).
4. Fit the upper wall and climbing shoes (50b + 51b), deactivate the climbing pawl. See Section "Fitting the suspension" on page 106.
5. Fit the climbing rail extension (7) at the upper end of the climbing rail (1) with 2x filler pins Ø 26 x 120 (17) and cotter pins 5/1 (18).
6. Fit the Climbing Device RCS 50 (60) on the climbing shoe (50c). Activate the climbing pawl in the climbing shoe.
7. Connect the climbing devices to the hydraulic unit, see Section "D6 Repositioning with the climbing device" on page 114.

(Fig. C4.05)

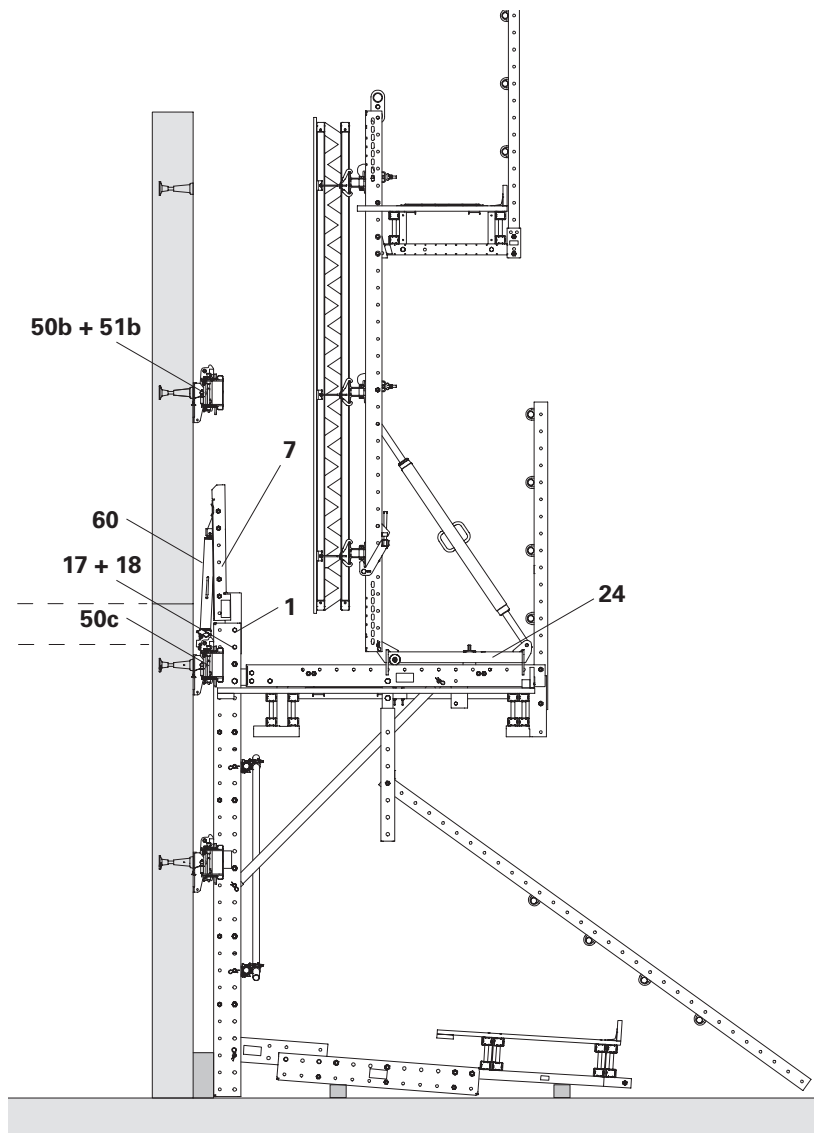

Fig. C4.05

First climbing procedure



Refer to the safety measures and climbing procedure in Section “D6 Repositioning with the climbing device” on page 114!

Components

- 2** Lower Climbing Rail RCS
- 5** Climbing Rail Connector RCS 73
- 33** Finishing platform
- 50** Climbing Shoe RCS
- 81** Guardrail Post 384 RCS

Assembly

1. Climb the climbing unit with the self-climbing hydraulics until the climbing rail extension threads into the climbing shoe (**50b**) above.



Watch the threading process. In the event of jamming, stop the climbing procedure and guide the climbing rail extension with pry bars.

2. Continue the climbing procedure. (Fig. C4.06)
 - The climbing rail (**2**) and climbing rail connector (**5**) swivel towards the structure.
 - The finishing platform (**33**) and guardrail post (**81**) are pulled towards the structure.
3. Stop the climbing procedure before the end of the upper climbing rail (**1**) reaches the lowest climbing shoe (**50d**) and as soon as the guardrail post (**81**) can be mounted on the finishing platform (**33**).

(Fig. C4.06a)

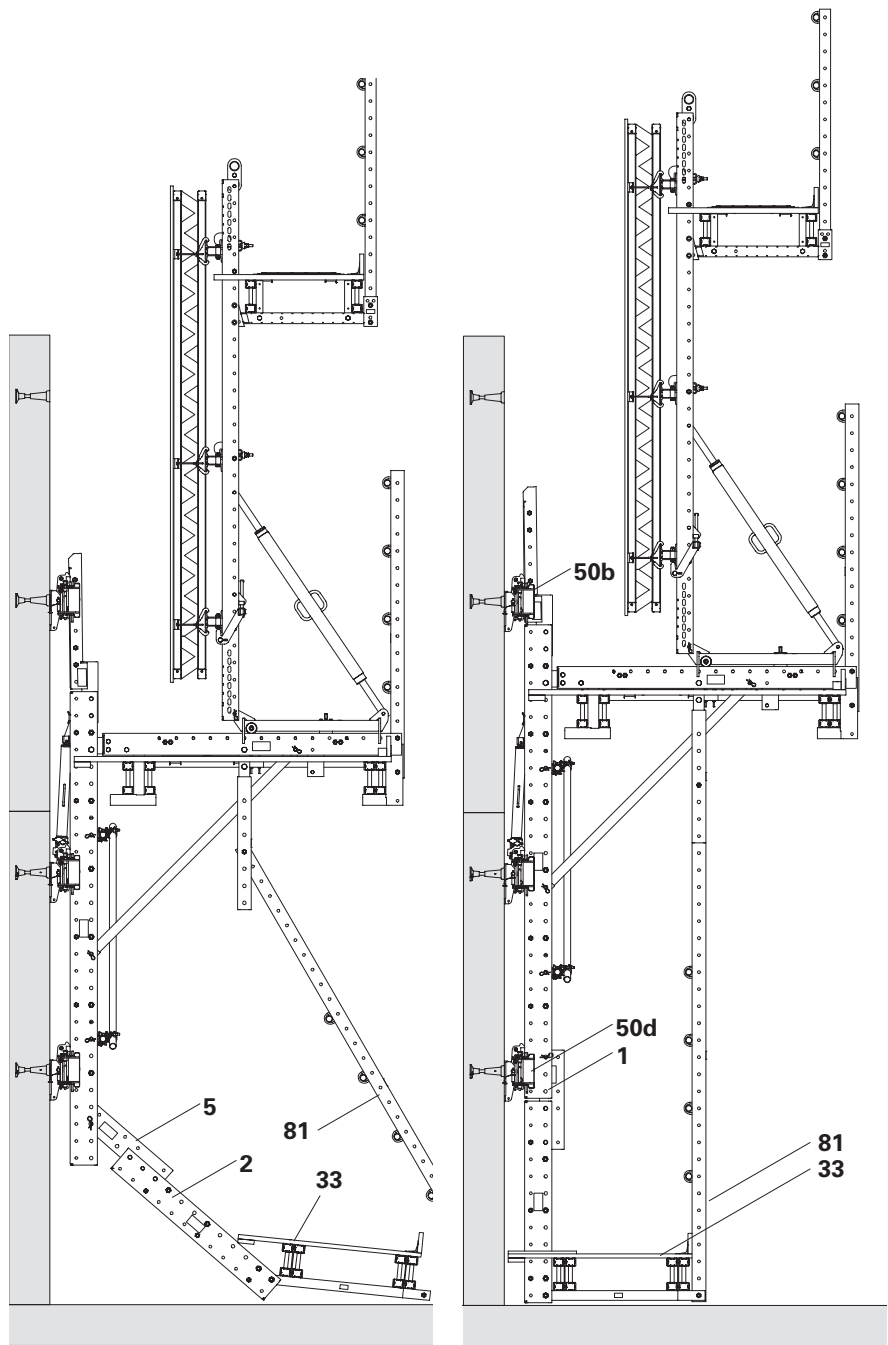

Fig. C4.06

Fig. C4.06a

Completing the finishing platform

Components

- 1** Upper Climbing Rail RCS 348
- 2** Lower Climbing Rail RCS 148
- 5** Climbing Rail Connector RCS 73
- 6** Climbing rail extension RCS 100
- 17** Filler pin \varnothing 26 x 120
- 18** Cotter pin 5/1
- 34** Finishing platform girder
- 81** Guardrail Post 384 RCS
- 106** Bolt ISO 4014-M20 x 120-8.8
- 115** Nut ISO 7040-M20-8

Assembly

1. Connect the climbing rail connector (**5**) rigidly to the upper climbing rail (**1**) using the fourth filler pin (**17**) and cotter pin (**18**).
2. Screw the guardrail post (**81**) to the finishing platform beam (**34**) with the bolt M20 x 1 20 (**34.1**) and nut (**34.2**) supplied.
3. Connect the guardrail post (**81**) rigidly to the pre-assembled climbing rail extension (**6**) using the second bolt M20 x 120 (**106**) and nut (**115**) supplied.
4. Fit lateral guardrails at the edge platforms, see Section "Lateral guardrails" on page 54.
5. Tighten bolt M24 x 130 (**34.1**) and nut (**34.2**) between the lower climbing rail (**2**) and finishing platform beam (**34**).
6. Continue the climbing procedure. (Fig. C4.07)

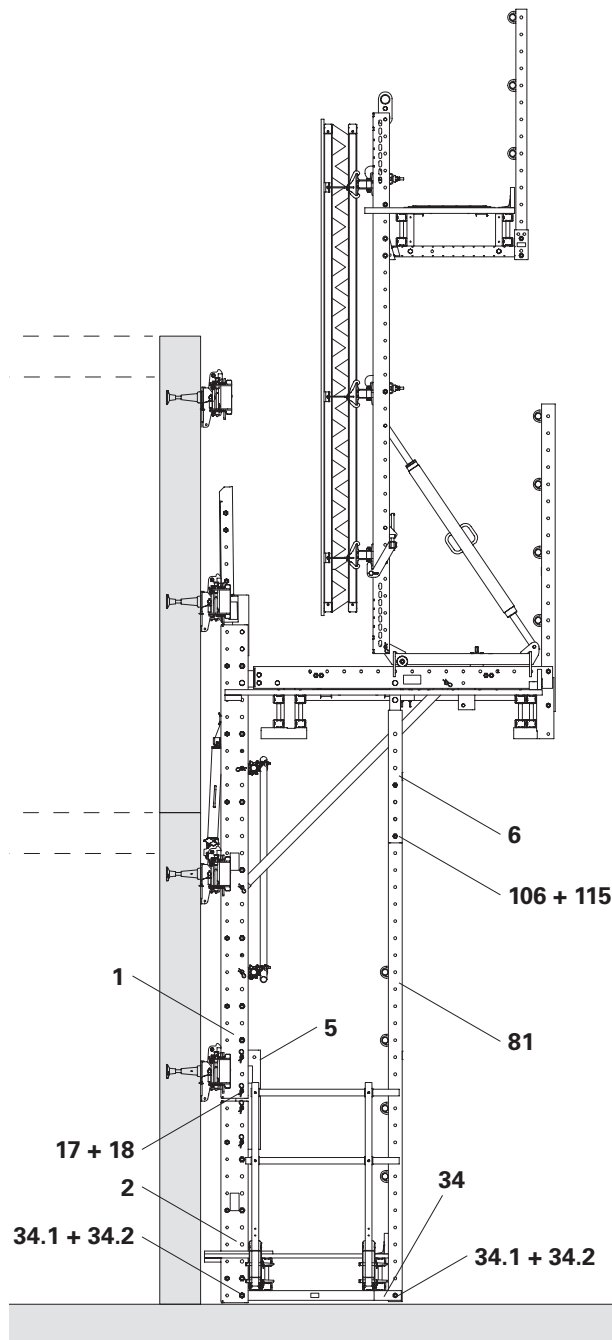

Fig. C4.07

Recovering the suspension

Components

- 1 Upper Climbing Rail RCS 348
- 7 Climbing rail extension RCS 125
- 50 Climbing Shoe RCS
- 54 Eccentric Lever RCS

Assembly

1. Stop the climbing procedure before the finishing platform reaches the lowest climbing shoe (50d).
2. Release the lowest climbing shoe with the eccentric lever (54) and remove the suspension, see Section "Dismantling the suspension" on page 107.
3. Fit the uppermost wall and climbing shoes (50a + 51a), deactivate the climbing pawl. See Section "Fitting the suspension" on page 106.
4. Continue climbing until the climbing rail extension (7) threads into the climbing shoe (50a) above.

(Fig. C4.08)



Watch the threading process. In the event of jamming, stop the climbing procedure and guide the climbing rail extension with pry bars.

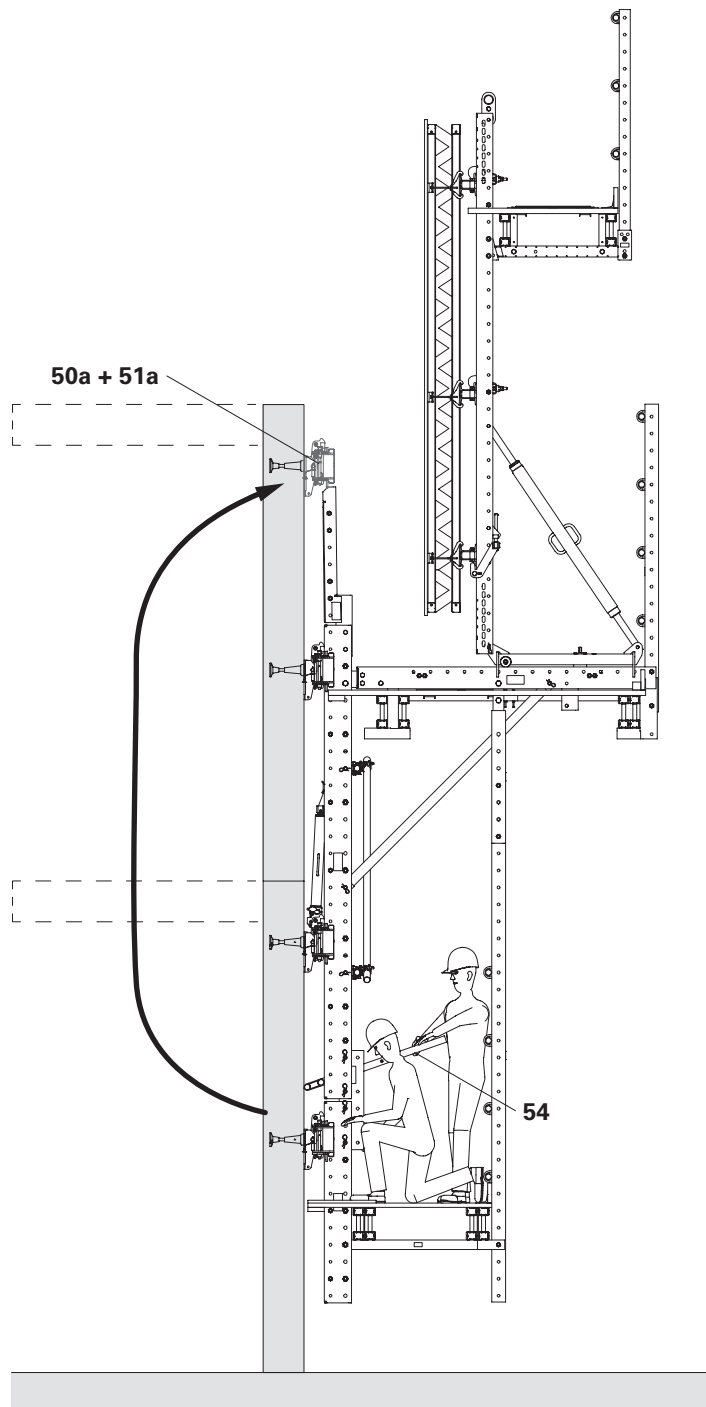

Fig. C4.08

Finishing the climbing procedure

Components

- 1 Upper Climbing Rail RCS 348
- 7 Climbing rail extension RCS 125
- 50 Climbing Shoe RCS

Assembly

1. Continue climbing until the upper climbing rail (1) is positioned in the uppermost climbing shoe (50a) in its entirety.
 2. Stop the climbing procedure and activate the climbing pawl of climbing shoe (50a) or (50b).
 3. Deactivate the climbing pawl on the climbing shoe that is carrying the climbing device (50c).
 4. Lift the climbing unit into the end position until the activated climbing pawl engages beneath the intended spacer.
 5. Set the climbing unit down on the climbing pawl ensuring that the load is fully supported.
 6. Remove the climbing rail extension (7) from the upper end of the climbing rail (1) and the climbing device.
- (Fig. C4.09)

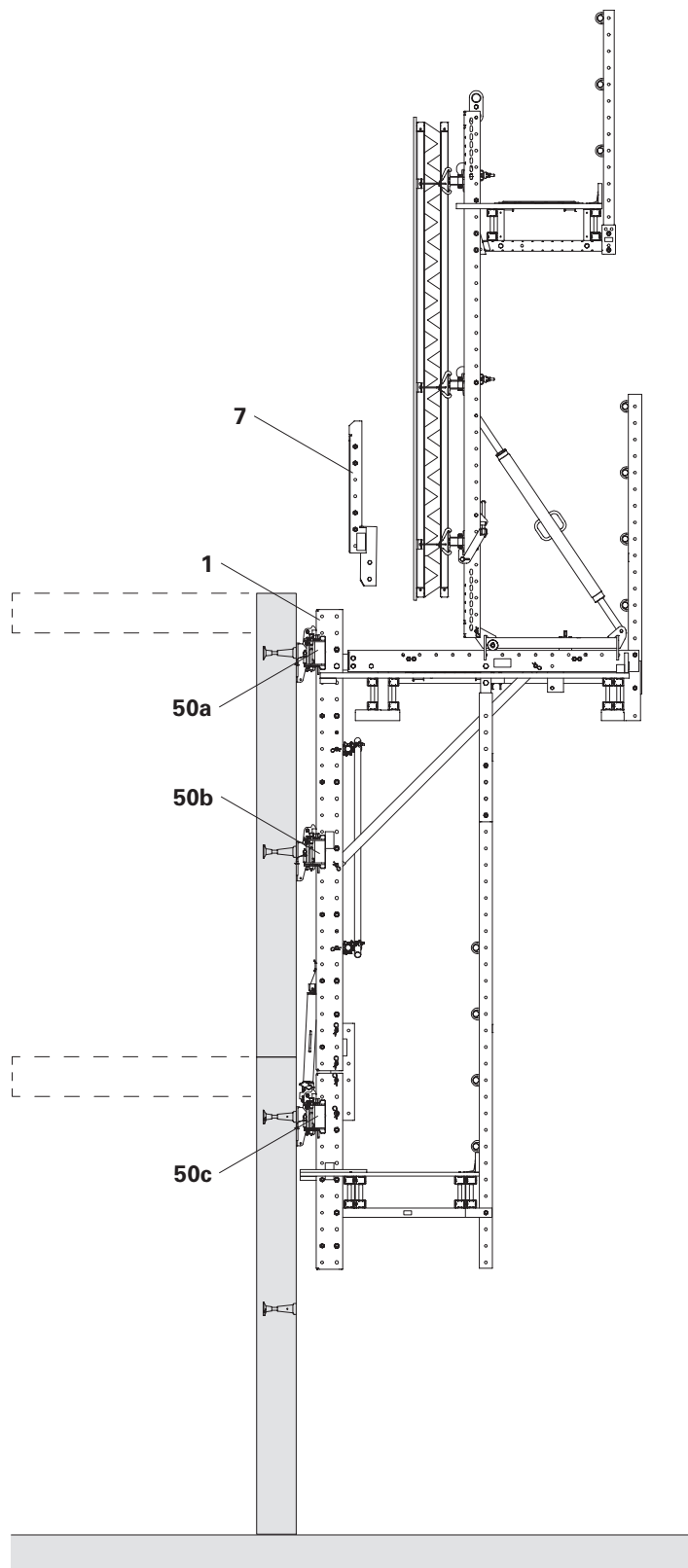

Fig. C4.09

Ladders



Do not use the ladder until it is securely attached at the top and bottom, and the ladder cage has been mounted. Assemble the ladder elements that are required for the project at hand.

Components

- 66** Hinged Hatch 55 x 60-2
- 67** Ladder 180/6
- 68** Ladder 220/6
- 69** Access Ladder 180/2
- 70** Ladder Base 30, adjustable
- 71** Ladder hook
- 72** Ladder Cage 75
- 73** Ladder Cage 150
- 101** Bolt ISO 4017 M12 x 40-8.8
- 118** Nut ISO 7040 M12-8
- 127** Wood screw 6x40 SK-TX30 HPI

Pre-assembling the ladder

- Permanently mounted ladder:
 1. Push top ladder 220/6 (**68**) with the connector (**68.1**) as far as possible into the lower ladder 180/6 (**67**).
 2. Secure the bottom ladder to the connector using the 4 bolts M12 x 40 and nuts (**68.2**) which have been provided.
 3. Install the ladder base (**70**) in the same manner with 4 bolts M12 x 40 (**101**) and nuts onto the connector (**67.1**) of the lower ladder.
 (Fig. C5.01)

- Lower ladder as hook-in ladder:
 1. Secure ladder hook (**71**) to the 2 bottom holes on the ladder rail using 4x bolts M12 x 25 and nuts (**71.1**) which have been provided.
 2. Securely mount the ladder base (**70**). See above.
 3. Attach hook-in ladder to the top ladder.
 (Fig. C5.02 + C5.03)

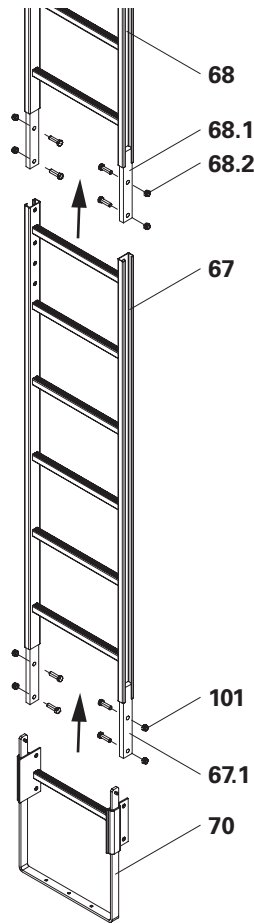

Fig. C5.01

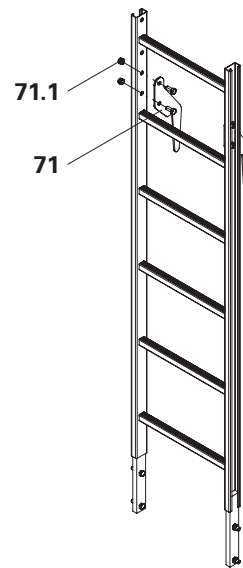

Fig. C5.02



The rungs of the hook-in ladder and top ladder must be positioned at the same height. Otherwise secure the ladder hooks using the correct holes.



Fig. C5.03

Fitting the ladder on the hatch

1. Lift the ladder using the crane. Lower ladder through hatch opening (66).
2. Fix ladder to the hatch from above using 2 bolts M12 x 40 and nuts (101 + 118).

(Fig. C5.04)

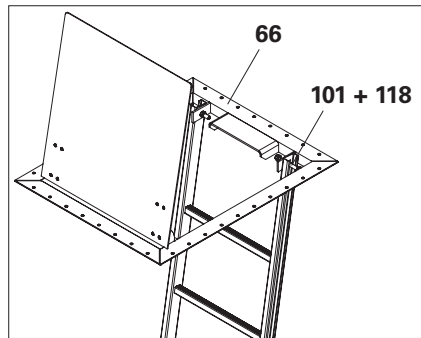

Fig. C5.04

Attaching the Access Ladder 180/2

1. Open the hatch cover (66.1).
2. Lift pre-assembled ladders (67 + 69) with the crane into the hatch (66) and lower so that the top rung of the ladder lies in the U-section of the hatch.

(Fig. C5.05)

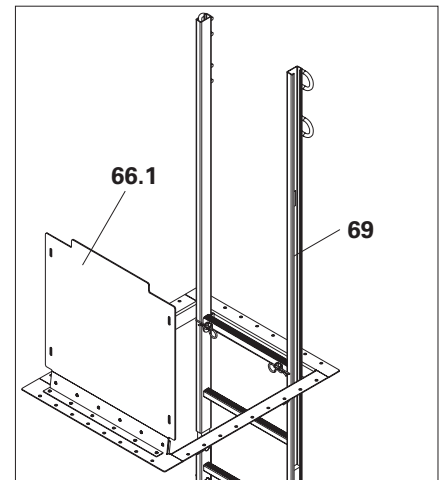

Fig. C5.05

Fixing the ladder base

1. Pull out the bracket (70.1) of the ladder base (70) as far as the platform decking. Screw the bracket to the planking with 3 wood screws 6x40 SK-TX30 HPI (127).

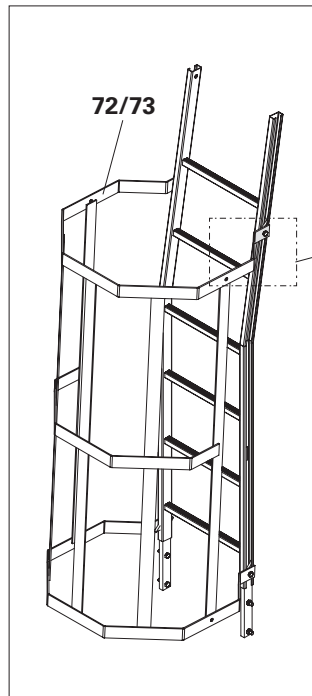
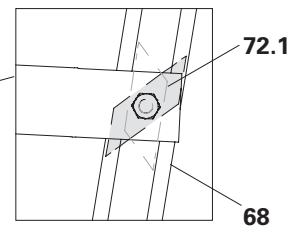

Fig. C5.06



Mounting the ladder cage



- The distance from the platform decking to the ladder cage ranges from 2.0 m to 2.5 m.
- The opening between two ladder cages must not exceed 50 cm.

1. Bring and hold the ladder safety cage (72) in position using a rope.
2. Slightly loosen screw M12 x 25 (4x) of the clamping plate (72.1), insert clamping plate into the ladder stile (68), turn and tighten screw.

(Fig. C5.06)



- The ladder can be used up to a platform distance of 7.0 m, according to the criteria of DIN EN 131-2.
- Maximum inclination $\alpha < 15^\circ$.

As a rule, climbing is carried out with a hydraulic climbing device. The procedure is different when climbing with a crane, see Section "D7 Repositioning with the crane" on page 128.



For storey heights that are multiples of 50 cm, PERI recommends installing an additional spacer in the climbing rails as a support.

Components

- 7 Climbing rail extension RCS 125
- 24 Carriage RCS
- 50 Climbing Shoe RCS
- 60 Climbing Device RCS 50

Step 1 – Concreting

Concrete the wall and ceiling with anchored formwork.

The vertical loads are introduced into the structure via the climbing shoe

(50c) or **(50d)**.

(Fig. D1.01)

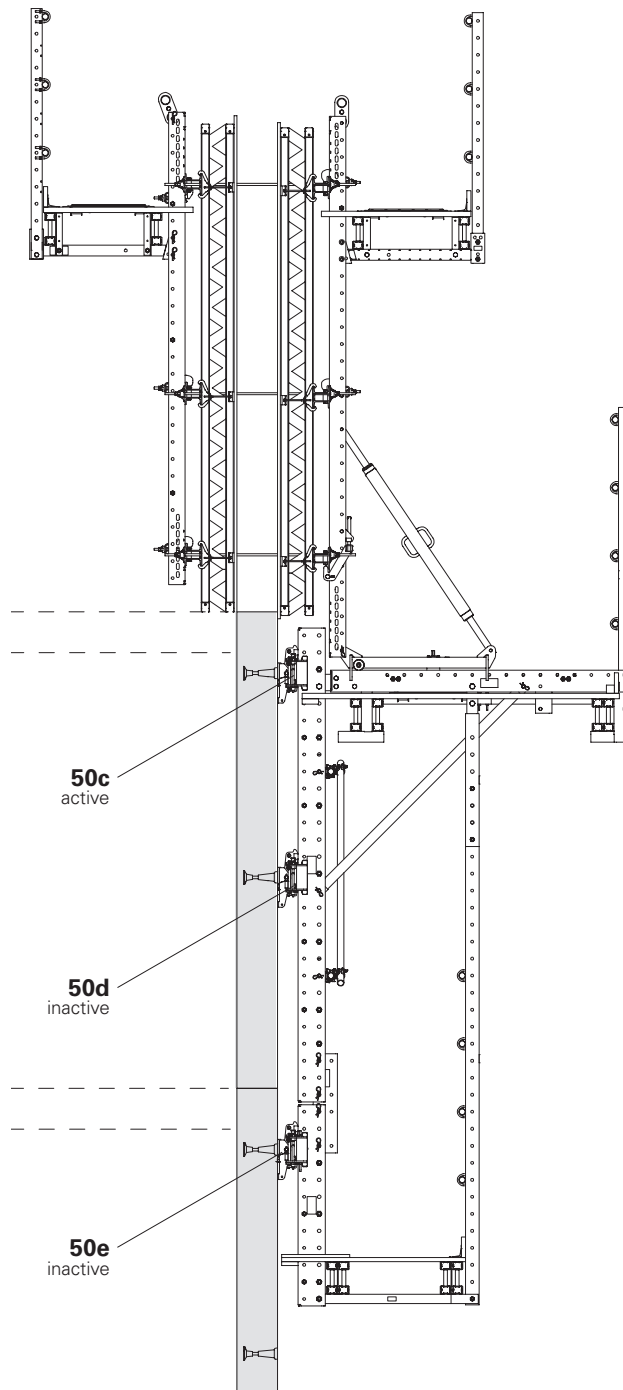

Fig. D1.01

Step 1

Step 2 – Deshuttering



The vertical distance between the climbing shoes (50c) and (50d) must be at least 1.50 m. Otherwise, do not remove the anchoring (50e) until the climbing rail extension (7) has retracted all the way into the climbing shoe (50b).

Release the leading tie fixing and deshutter the concreting section. Retract the formwork with the carriage (24).

Remove the wall and climbing shoe (50e) in the area of the finishing platform and mount it in advance on the new concreting section (50b).

Remove the anchoring, close the tie hole, if necessary.

Mount the climbing rail extension (7) with the filler pin and cotter pin supplied.

(Fig. D1.02)

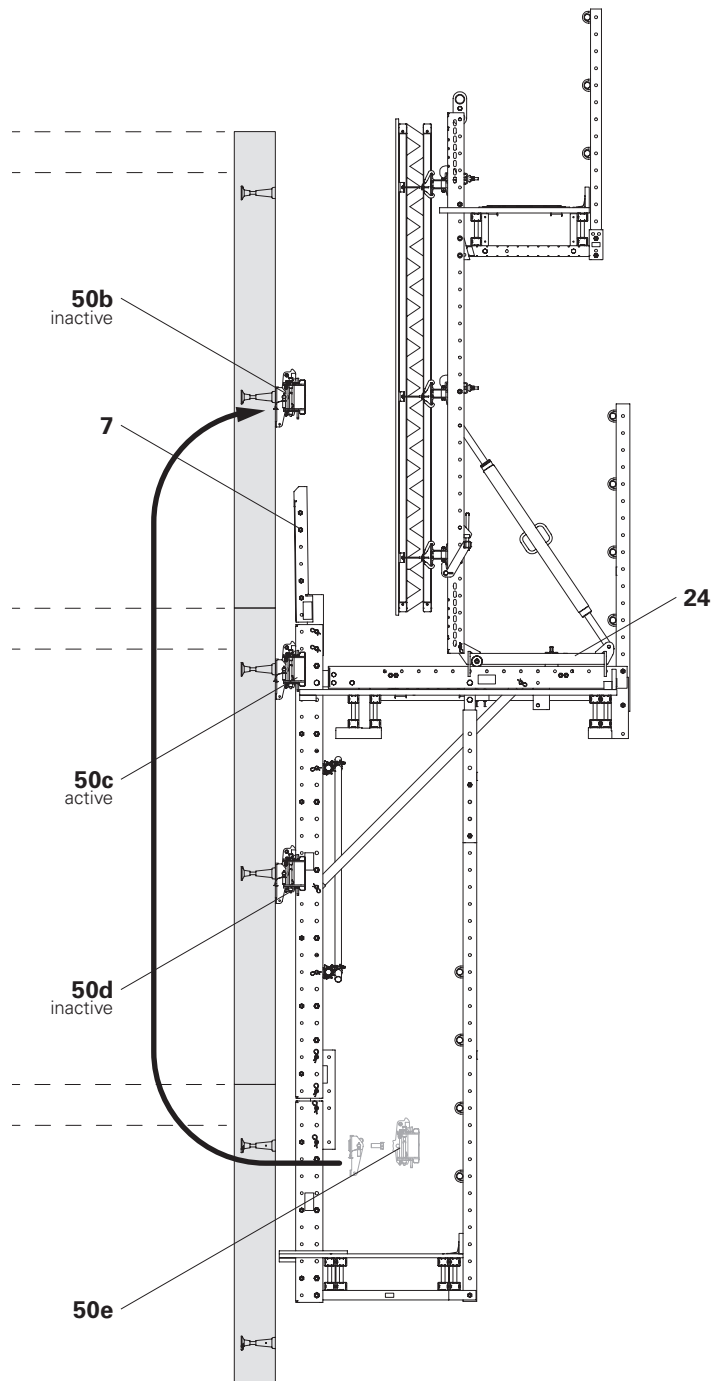

Fig. D1.02

Step 2

Step 3 – Self-climbing

Fit the climbing devices (60) on the climbing shoe (50c) and connect it to the hydraulic unit.

Climb in strokes of 50 cm.

(Fig. D1.03)



Watch the threading process. In the event of jamming, stop the climbing procedure and guide the climbing rail extension with pry bars.

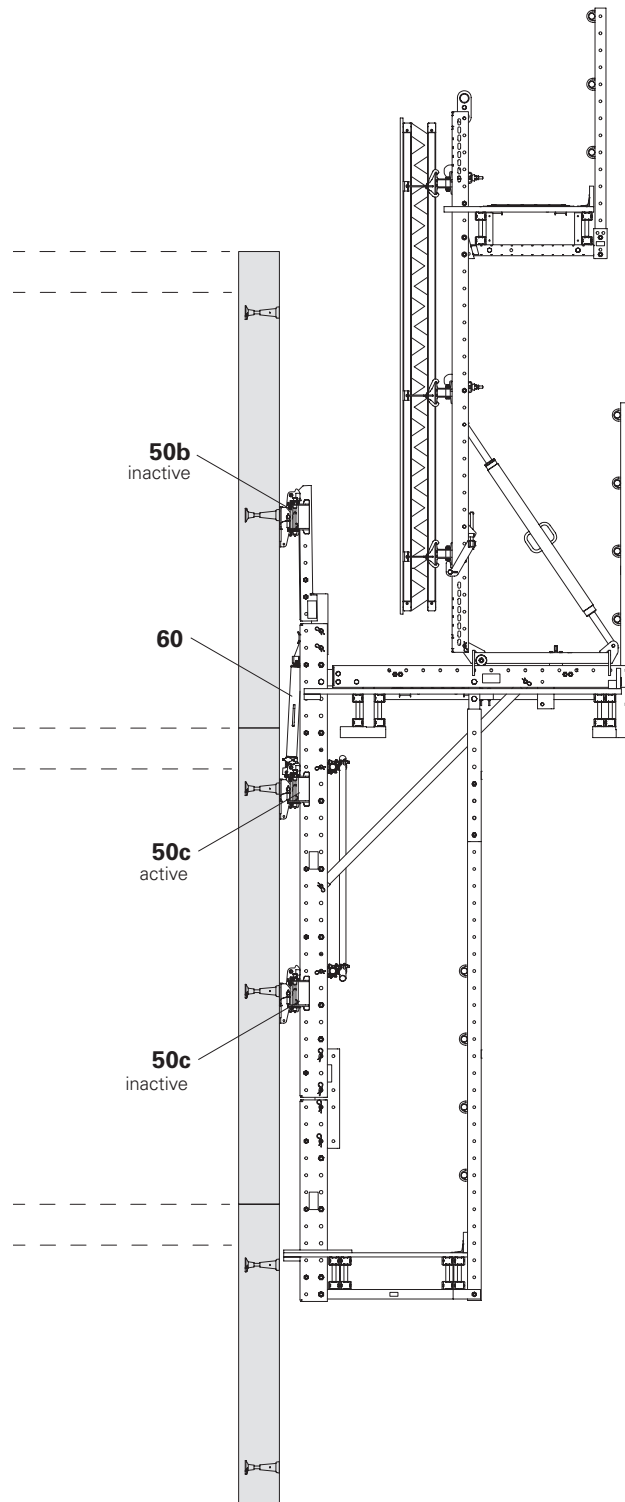

Fig. D1.03

Step 3

Step 4 – Reposition the climbing shoes

Stop the climbing procedure.
 Remove the climbing shoe (50d) and leading tie. Fit the recovered climbing shoe as a leading climbing shoe (50a).
 Activate the climbing pawl of the climbing shoe (50a).
 Continue climbing.
 (Fig. D1.04)



Watch the threading process. In the event of jamming, stop the climbing procedure and guide the climbing rail extension with pry bars.

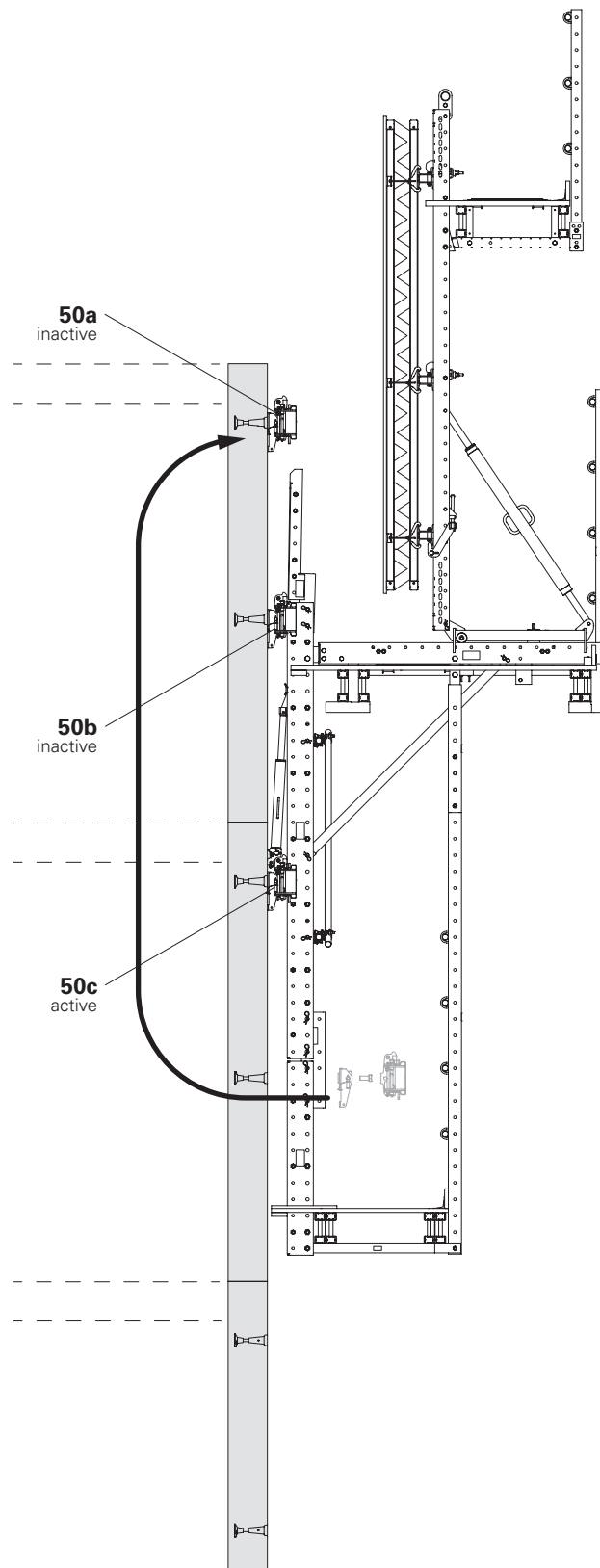

Fig. D1.04

Step 4

Step 5 – Set the climbing unit down

With the final stroke, set the climbing unit down completely on the intended climbing shoe (50a) together with the intended spacer, ensuring that the load is fully supported.

Remove the climbing rail extension (7) from the upper end of the climbing rail (1) and the climbing device (60).

(Fig. D1.05)

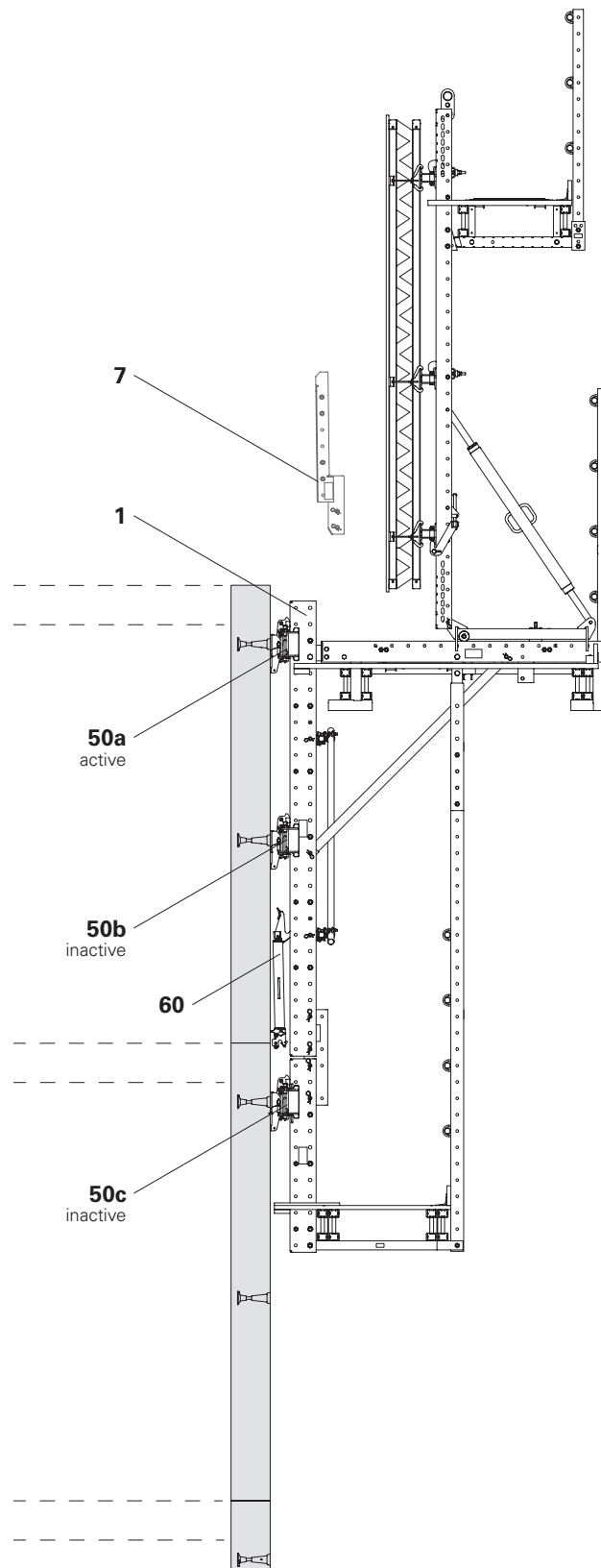

Fig. D1.05

Step 5

Step 6 – Concrete the standard cycle

Attach the leading tie to the formwork.
Move the formwork to the wall using the carriage (24).
Adjust the formwork.
Install reinforcement.
Position the internal formwork and anchor it against the external formwork.
Concrete the wall.
The external wall formwork also serves as the stop end formwork for the slab.
(Fig. D1.06)

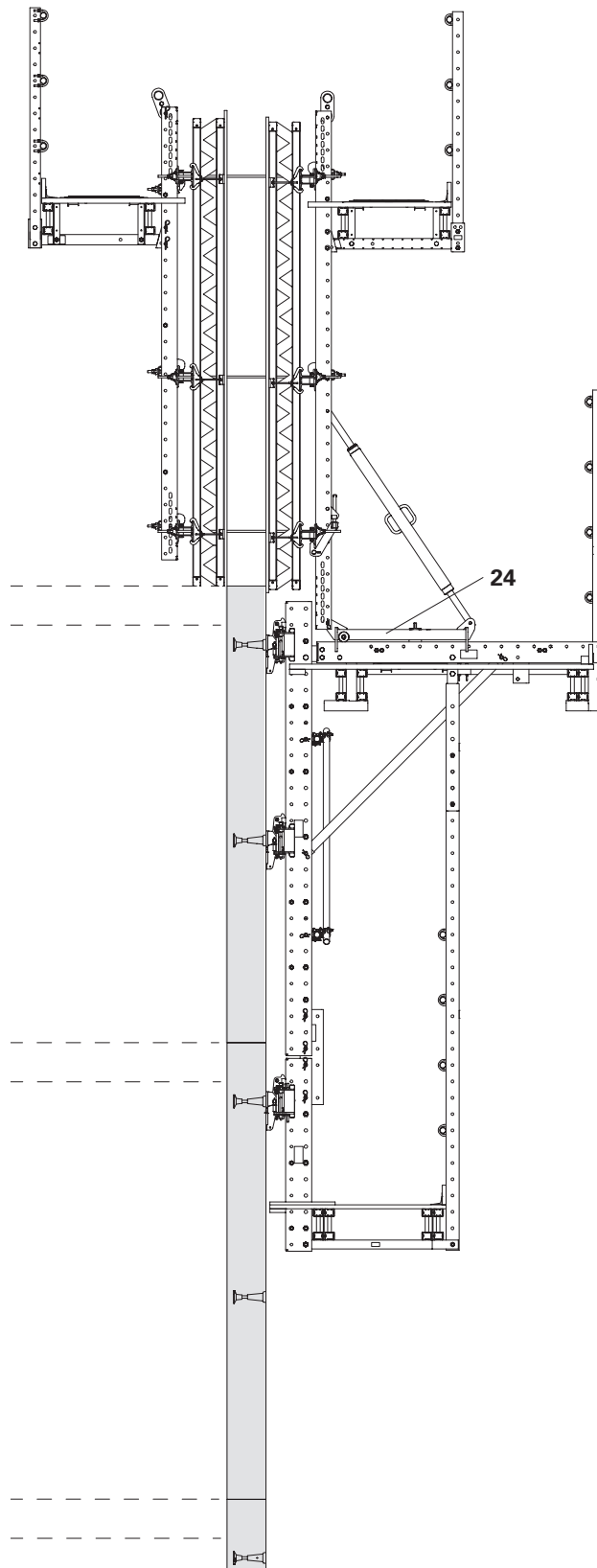

Fig. D1.06

Step 6

Operating the carriage

Components

24 Carriage RCS

1. Turn the traction screw (24.3) with the Carriage Crank Lever AF 19 (24.4) and thereby move the Carriage (24) towards or away from the wall.
 - The max. travel distance is approx. 90 cm.
 - During the moving process, operate both carriages of a platform at the same time.

(Fig. D2.01)



Have all positioning screws, formwork ties and connections to the formwork units of the adjacent platforms been removed?

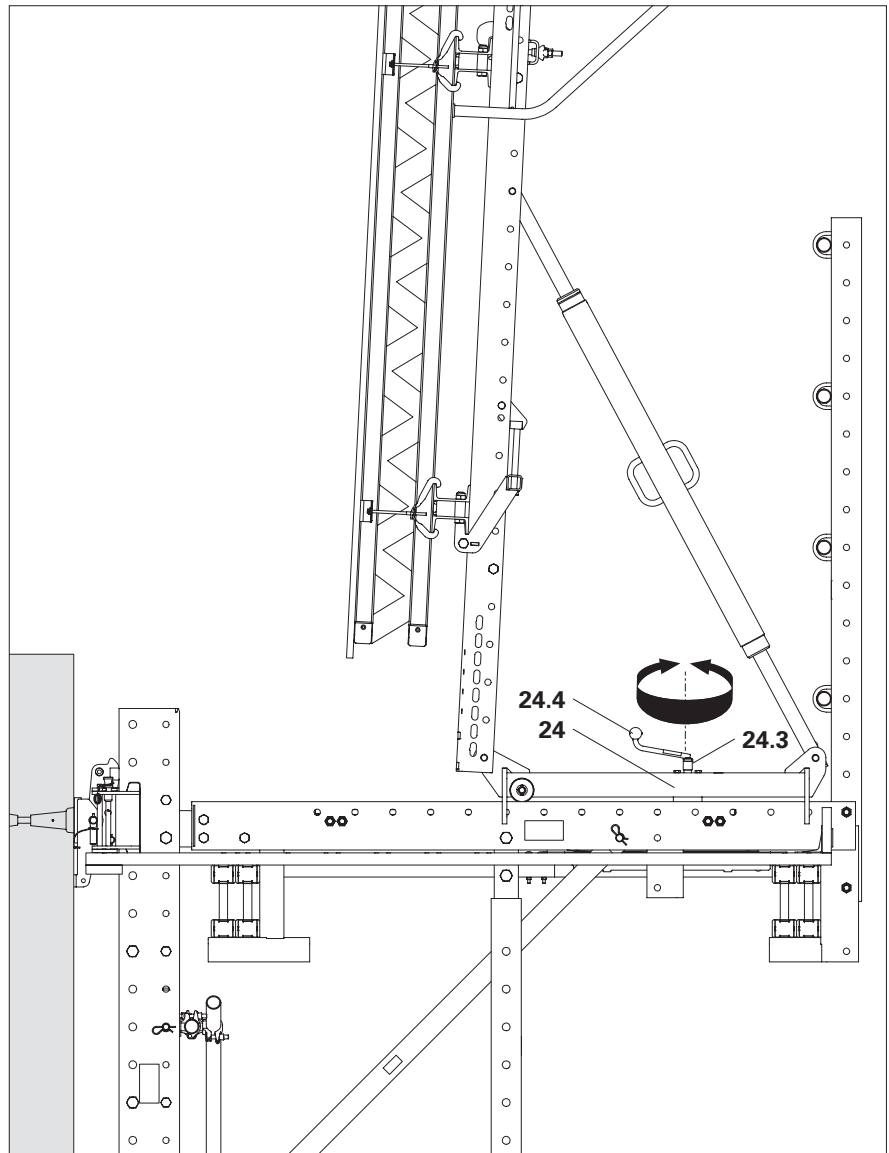

Fig. D2.01

Adjusting the formwork

Components

- 25** Steel Waler Universal SRU L = 2.72
- 26** Waler Fixation U100 – U120
- 27** Height Adjustment Unit SRU, outer
- 28** Heavy Duty Spindle SLS 200/300

Ensuring the formwork is vertical

1. Hold the spirit level against the formwork and move the formwork into a vertical position by turning the formwork spindle (**28**). (Fig. D2.02)



Is the formwork flush with the wall?

Adjusting the height:

1. Loosen the waler fixation (**26**) slightly.
2. Set the formwork to the exact height by turning the height adjustment unit (**27**).
3. Tighten the waler fixation.

Moving the formwork horizontally:

1. Loosen the waler fixation (**26**) slightly.
2. Move the formwork with the lever against the strongback (**25**).
3. Tighten the waler fixation.

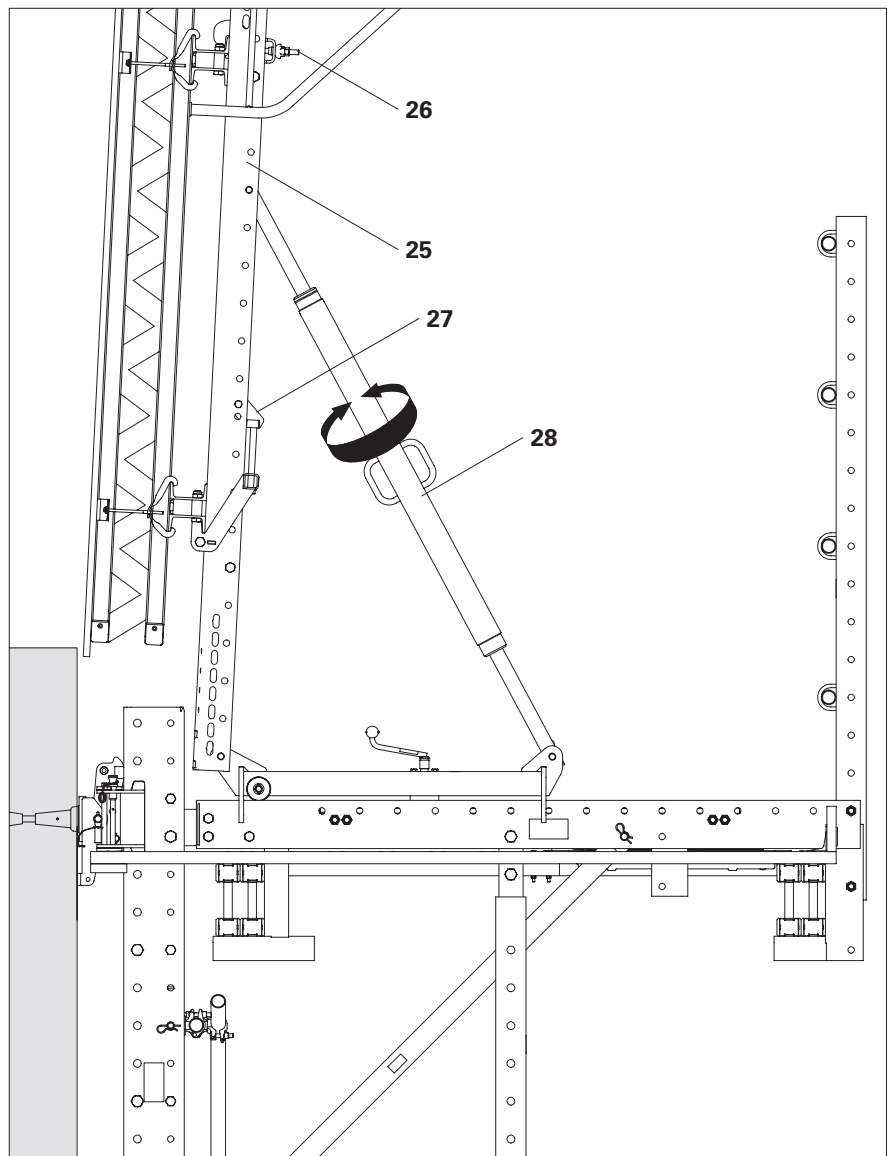

Fig. D2.02

Releasing the leading tie

Components

42.1 Positioning screw

42.2 Anchor Positioning Stud M30

Preparation

Remove all connections, e.g. couplings, from the formwork units of the adjacent climbing units.

Standard: Positioning screw

Disassembly

1. Release Positioning Screws M30 (**42.1**) and remove. (Fig. D3.01)
2. Release the formwork using the heavy-duty spindle.
3. Strike the formwork using the carriage, see Section "D2 Operating the formwork" on page 102.

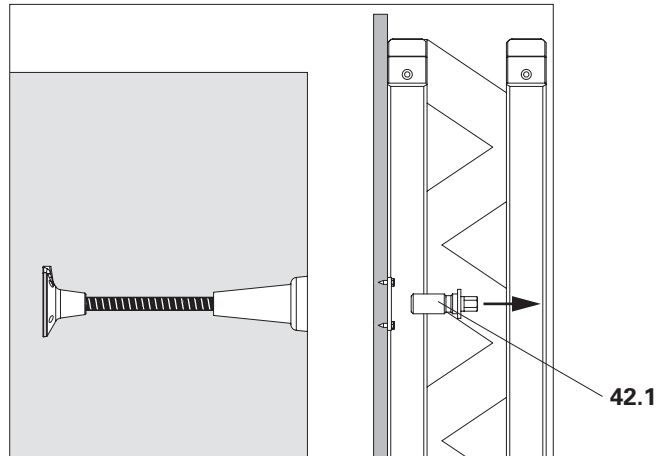

Fig. D3.01

Alternatively: Anchor positioning stud

Disassembly

1. Straighten wire nails $\text{Ø } 3 \times 80$ (**143**).
2. Release the formwork using the heavy-duty spindle.
→ Pull wire nails $\text{Ø } 3 \times 80$ (**143**) out of the formlining. (Fig. D3.02)
3. Strike the formwork with the carriage.
4. Bend wire nails $\text{Ø } 3 \times 80$ (**143**) in order to protect hands.
5. Remove Anchor Positioning Stud M30 (**42.2**) using Allen key AF 14. (Fig. D3.03)

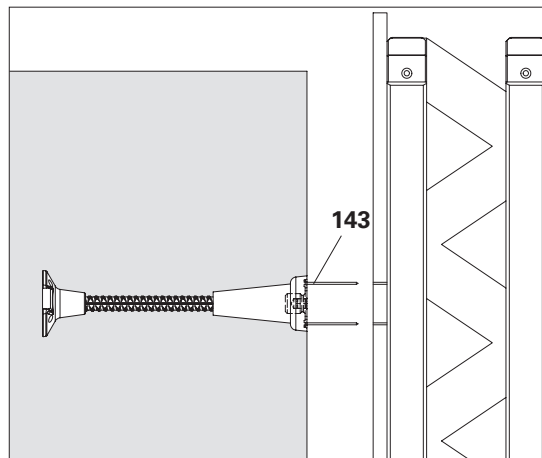

Fig. D3.02

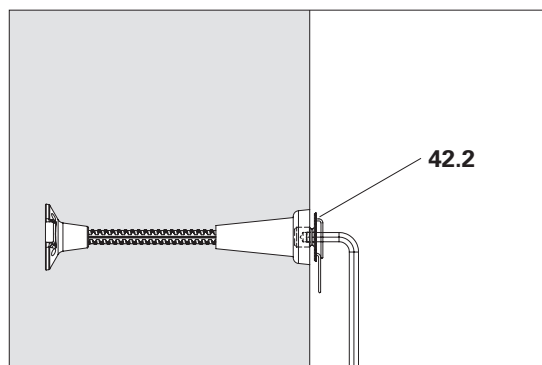

Fig. D3.03

Fitting the suspension

Components

- 47** Anchoring
- 50** Climbing Shoe RCS
- 51** Wall Shoe RCS

Fitting the wall shoe

1. Pull the cotter pin (**51.3**) out of the locking pin and pull the locking pin (**51.1**) out of the Wall Shoe RCS.
2. Leave the cotter pin in the locking pin.
3. Screw the Wall Shoe RCS to the anchoring (**47**) with the hex. bolt M30 x 70-8.8 (**51.2**). Tightening torque 260 Nm.

(Fig. D4.01 + D4.01a)

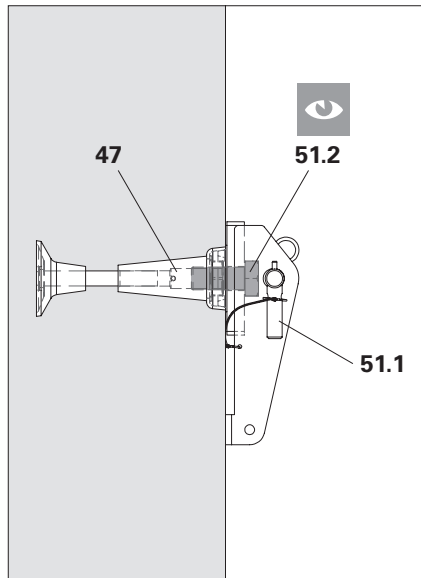

Fig. D4.01

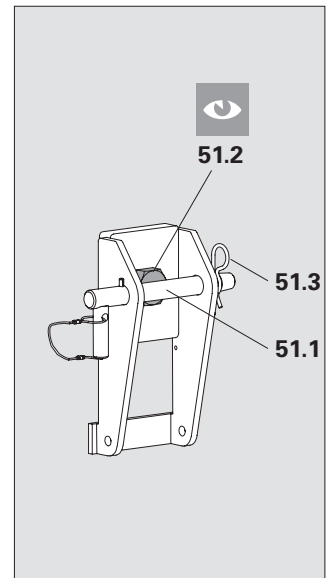

Fig. D4.01a



Is the screw tightened?

Installing the climbing shoe

1. Insert the Climbing Shoe RCS (**50**) into the Wall Shoe RCS (**51**).
2. Insert the locking pin (**51.1**) through the stringers of the wall shoe and climbing shoe and secure with the cotter pin (**51.3**).
3. Depending on the situation, deactivate or activate the climbing pawl (**50.1**) in the climbing shoe, or open or close the guiding skids (**50.2**). See Section "D5 Operating the climbing shoe" on page 110.

(Fig. D4.02 + D4.02a)

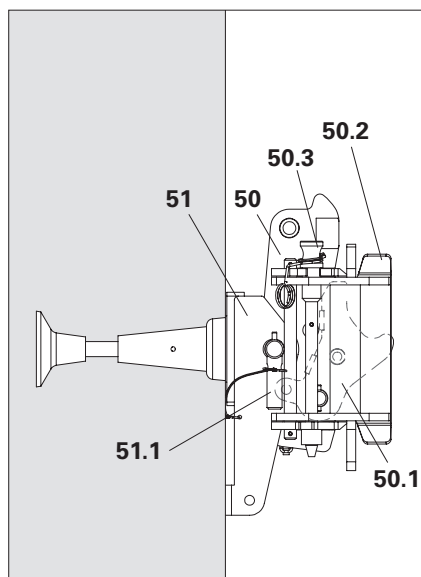

Fig. D4.02

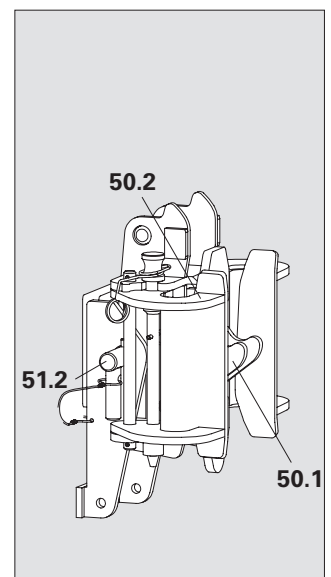

Fig. D4.02a



- Have all the locking pins (**50.3**) on the climbing shoes been pushed all the way down?
- Is the locking pin (**51.1**) secured with a cotter pin?
- Is the climbing shoe aligned completely vertically?

Dismantling the suspension

Components

- 2** Lower Climbing Rail RCS
- 50** Climbing Shoe RCS
- 51** Wall Shoe RCS
- 54** Eccentric Lever RCS



Warning

- During assembly on the construction site, components may fall to the ground and hit people below! This can lead to serious injuries or even death.
 - ⇒ Secure all components, e.g. with ropes.
 - ⇒ Cordon off danger zones beneath the working areas.
- The climbing rail can spring back! As a result, body parts can become trapped and seriously injured.
 - ⇒ Make sure that the eccentric lever is fixed in place sufficiently by the friction.
 - ⇒ Have a 2nd person hold the eccentric lever tight.
 - ⇒ Do not reach into clamping points.

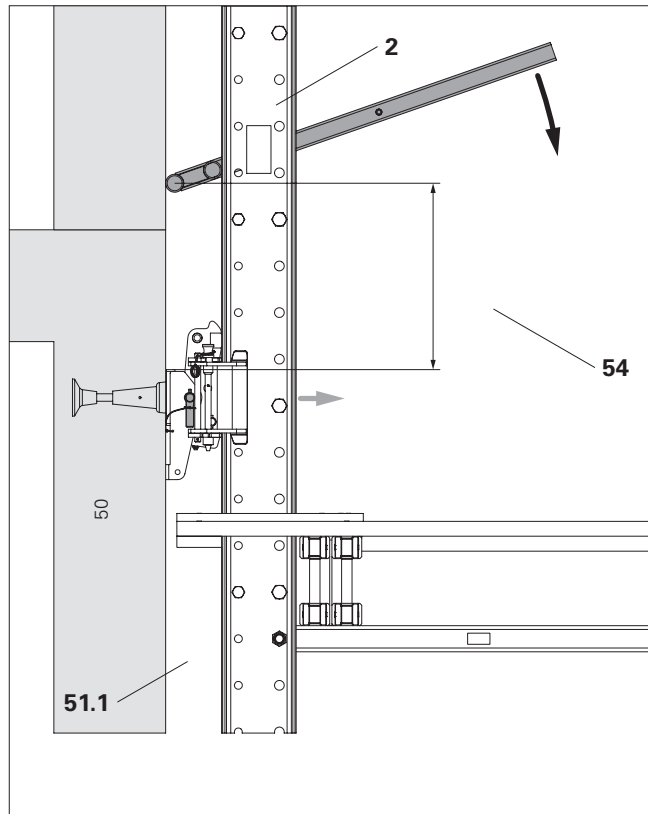

Fig. D4.03

Disassembly

1. Insert Eccentric Lever RCS (**54**) between the wall and the lower climbing rail (**2**) from the side. For the climbing shoe to be removed a distance of at least 50 cm from the wall shoe is required.
 2. Push the climbing rail away from the wall with the eccentric lever until the locking pin (**51.1**) in the wall shoe is disengaged. Have a 2nd person hold the eccentric lever tight.
 - The climbing shoe is now released.
- (Fig. D4.03 + D4.03a)

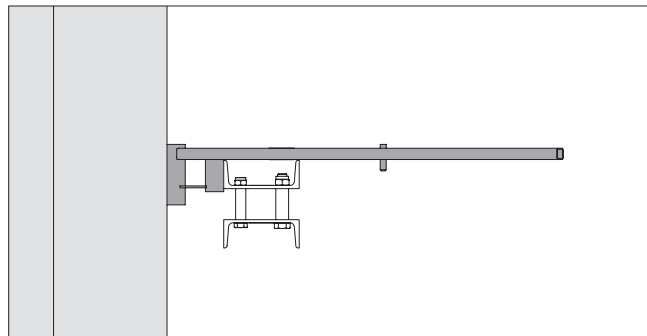

Fig. D4.03a

Top view

3. Open both guiding skids (**50.2**).
4. Deactivate the climbing pawl in the climbing shoe. See Section "D5 Operating the climbing shoe" on page 110.
5. Hold the climbing shoe tight (**50**) and pull the locking pin (**51.1**) out of the Wall Shoe RCS (**51**).
6. Pull the climbing shoe upwards, then out to the side behind the climbing rail. (Fig. D4.04 + D4.04a)
7. Replace the locking pin and cotter pin. Hold the wall shoe tight and unscrew the hex. bolt M30 x 70-8.8 (**51.2**).
8. Pull the Wall Shoe RCS out to the side behind the climbing rail.
9. **Caution!** The eccentric lever (**54**) jumps up when lifted. Carefully lift the eccentric lever until the climbing rail is disengaged.

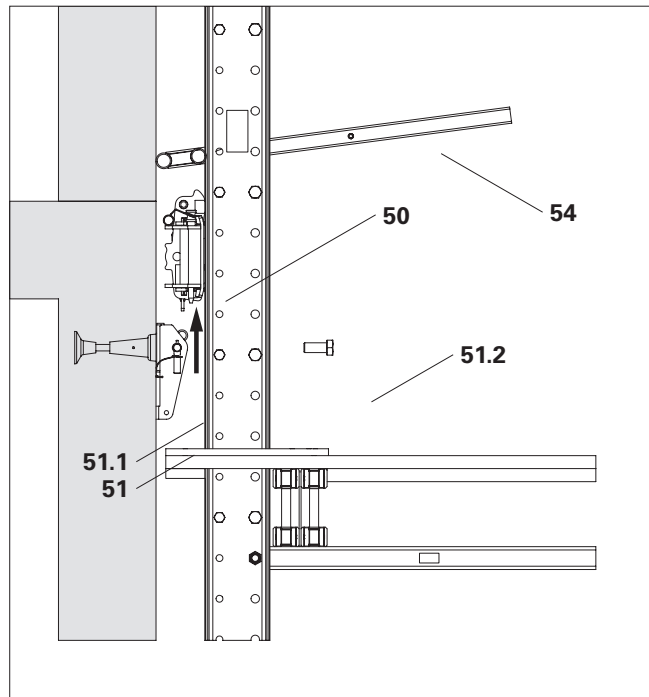

Fig. D4.04

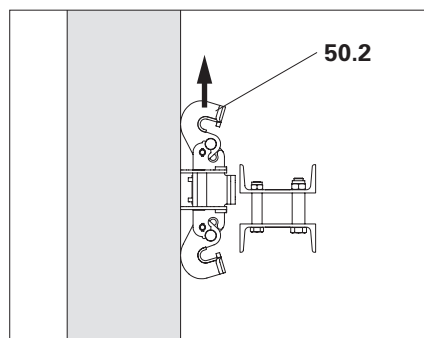

Fig. D4.04a

Top view

Removing climbing cones

Components

47.1 Screw-On Cone-2 M30/DW 26

47.5 Climbing Cone-2 M30/DW 20

Disassembly

1. Loosen the reusable part of the anchoring with a ring wrench AF 46 and unscrew it completely:

- Climbing Cone-2 M30/DW 20 (**47.5**).
- Screw-On Cone-2 M30/DW 26 (**47.1**).



- If necessary: seal the tie hole with KK Concrete Cone M30-80/52 (**47.9**) and PERI sealing compound so it is watertight.
→ See User Information for Concrete Cones with Sealing Compound-3.

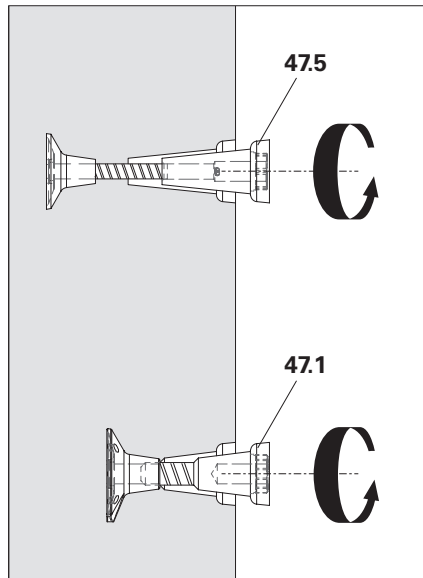

Fig. D4.05

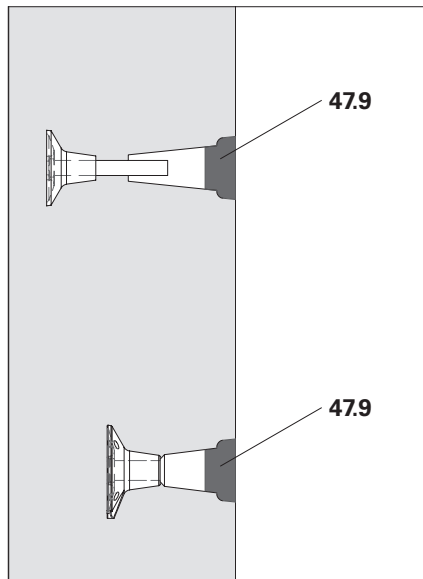

Fig. D4.06

Opening and closing the climbing shoe

The safety pins (50.3) hold the guiding skids (50.2) in a closed position. (Fig. D5.01 + D5.01a)

Components

- 50 Climbing Shoe RCS
- 50.2 Guiding skids
- 50.3 Safety pins
- 50.6 Spring lock

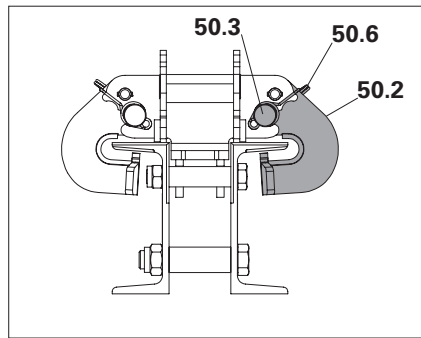

Fig. D5.01

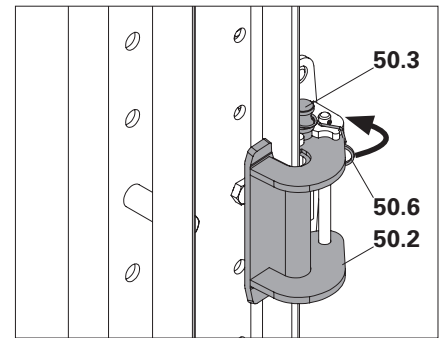

Fig. D5.01a

Opening the climbing shoe

1. Release the locking spring (50.6). For this, pull out the ring under the guiding skid (50.2). (Fig. D5.01 + D5.01a)
2. Lift safety pin (50.3).
3. Fold up guiding skids (50.2). (Fig. D5.02 + D5.02a)
4. Re-insert safety pins (50.3) in the opened position; place the locking spring (50.6) only loosely on the guiding skid. (Fig. D5.03 + D5.03a)
5. Proceed in the same way with the other guiding skid. (not shown)

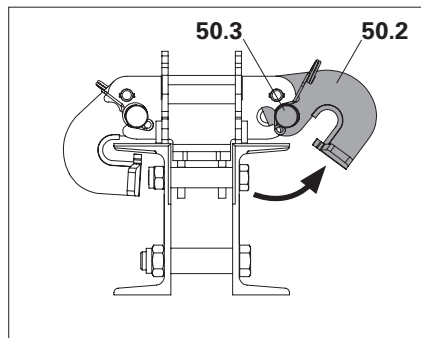

Fig. D5.02

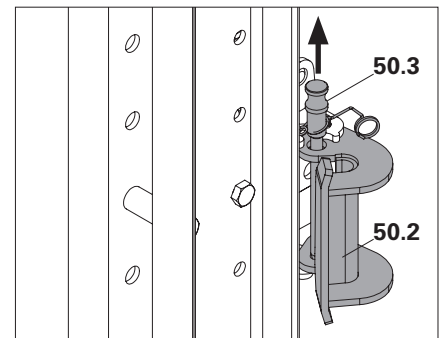

Fig. D5.02a



Opening the guiding skids facilitates the process of inserting the climbing rail during climbing and allows the climbing rail to be inserted during initial assembly.

Danger

Do not open the guiding skids of any Climbing Shoe that is under load / supporting the Rail.

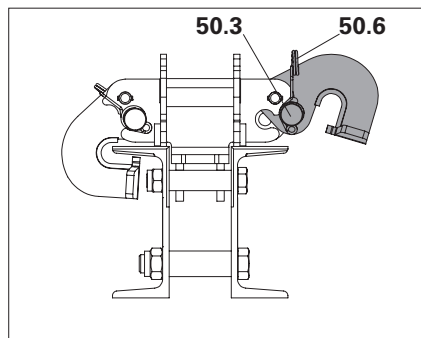

Fig. D5.03

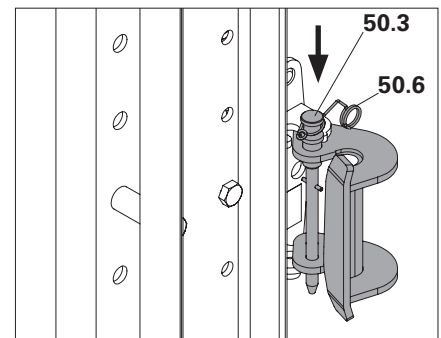

Fig. D5.03a

D5 Operating the climbing shoe

Closing the climbing shoe

1. Lift safety pin (50.3).
(Fig. D5.04 + D5.04a)
2. Fold guiding skid (50.2) forwards.
(Fig. D5.05 + D5.05a)
3. Fully re-insert the safety pin (50.3) in the closed position.
4. Fix the locking spring in place (50.6).
For this, the ring is snapped into place under the guiding skid (50.2).
5. Proceed in the same way with the other guiding skid.

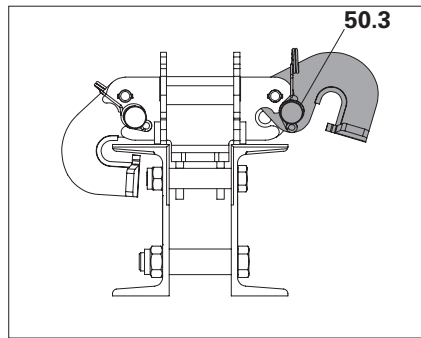

Fig. D5.04

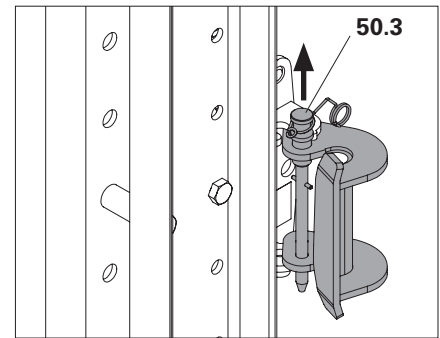

Fig. D5.04a



Are both locking pins completely inserted and is the locking spring fixed in position?

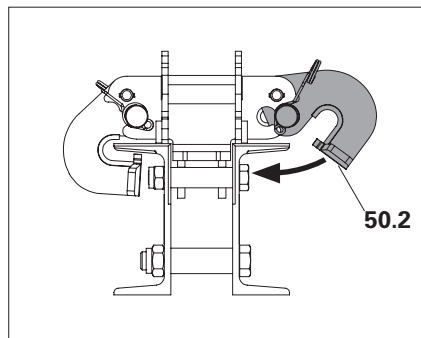

Fig. D5.05

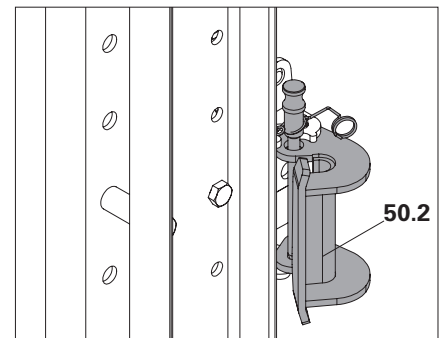

Fig. D5.05a

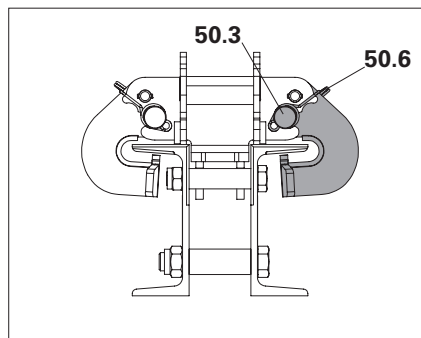

Fig. D5.06

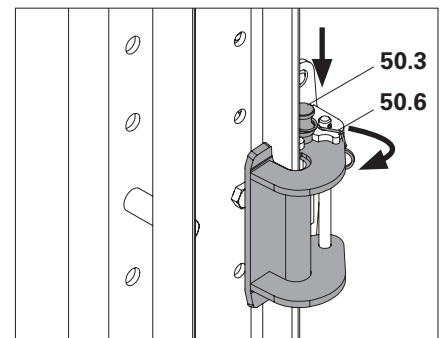

Fig. D5.06a

Activating and deactivating the climbing pawl



Warning

Hands can become trapped between climbing rails and climbing shoes! This can result in serious injuries.

- ⇒ Only activate or deactivate the climbing pawl when the climbing unit has stopped moving.
- ⇒ Do not reach into the climbing rail during the climbing procedure.

Components

- 50** Climbing Shoe RCS
- 50.1** Climbing pawl
- 50.4** Pawl lock
- 50.5** Hinged clamp

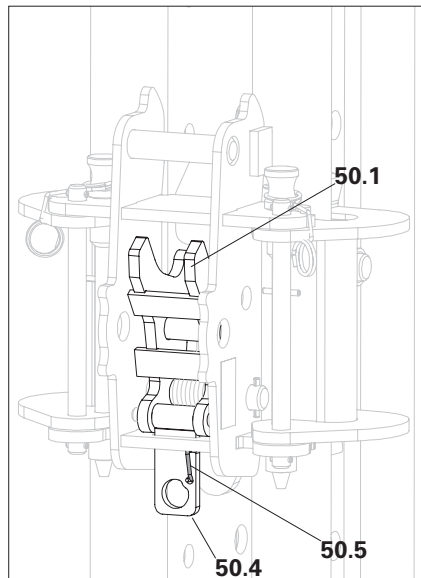

Fig. D5.07

Deactivating the climbing pawl

1. Ensure that the climbing unit is stationary.
 2. Pull down the pawl lock (**50.4**) on the climbing shoe.
 3. Fold up the hinged clamp (**50.5**) on the pawl lock and then let go of the pawl lock.
 - The hinged clamp is then clamped and blocks the pawl lock.
 - The climbing pawl (**50.1**) is deactivated and therefore non-operational.
- (Fig. D5.07 + D5.07a)



In this position, no vertical forces from the climbing rail can be transferred via this particular shoe.

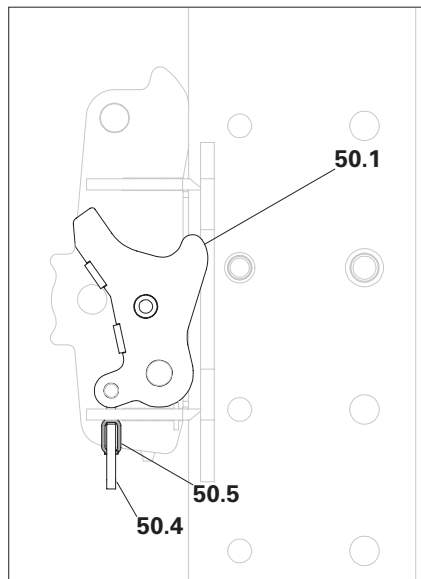

Fig. D5.07a

Activating the climbing pawl

1. Ensure that the climbing unit is stationary.
 2. Pull down the pawl lock (50.4) on the climbing shoe.
 3. Fold down the hinged clamp (50.5) on the pawl lock and then let go of the pawl lock.
 - The climbing pawl (50.1) jumps into its working position.
 - The climbing pawl is activated and therefore operational.
- (Fig. D5.08 + D5.08a)



Can the climbing pawl (50.1) move freely?
Is the hinged clamp (50.5) hanging downwards?



- This position serves the purpose of transferring vertical forces from the climbing rail during working operations and climbing.
- For storey heights that are dividable by 50 cm, only activate the pawls on the climbing shoes that serve as the planned vertical support. Deactivate all other climbing shoes.

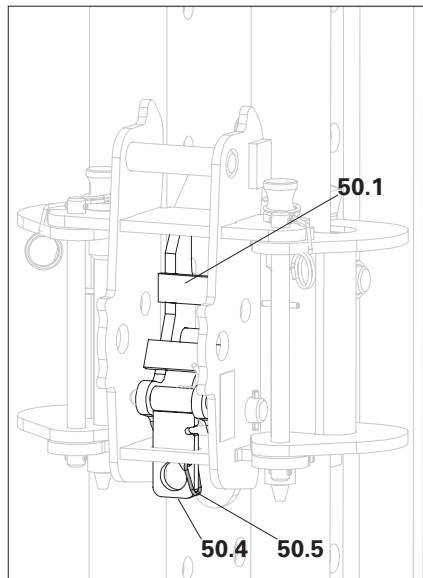

Fig. D5.08

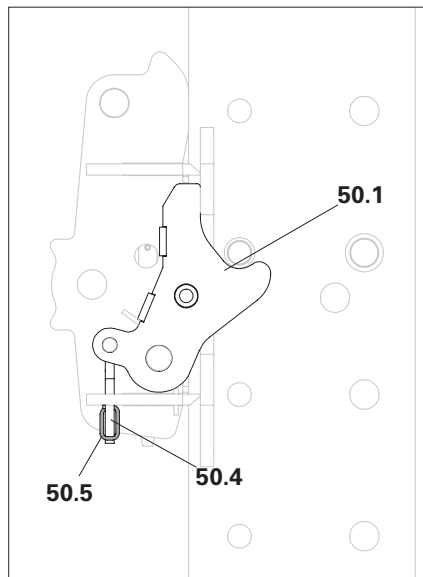

Fig. D5.08a

D5 Operating the climbing shoe (With Climbing Shoe Display RCS)

Activating and deactivating the climbing pawl

Warning

Hands can become trapped between climbing rails and climbing shoes! This can result in serious injuries.

- ⇒ Only activate or deactivate the climbing pawl when the climbing unit has stopped moving.
- ⇒ Do not reach into the climbing rail during the climbing procedure.

Components

- 50** Climbing Shoe RCS
- 50.1** Climbing pawl
- 50.9** Climbing Shoe Display RCS

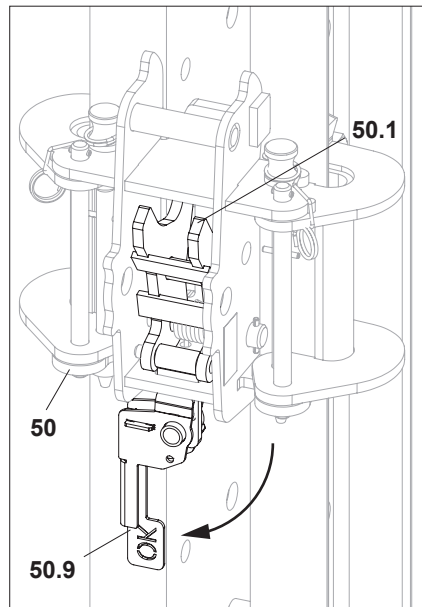

Fig. D5.09

Deactivating the climbing pawl

1. Ensure that the climbing unit is stationary.
2. Swing the Climbing Shoe Display RCS (**50.9**) on the Climbing Shoe RCS (**50**) downwards until it engages in a vertical position.
 - The climbing pawl (**50.1**) is deactivated and therefore non-operational.

(Fig. D5.09 + D5.09a)



- In this position, no vertical forces from the climbing rail or from the drive rail can be transferred via this particular shoe.
- Deactivating the climbing pawl prevents unintentional engagement with the pins of the climbing rail.

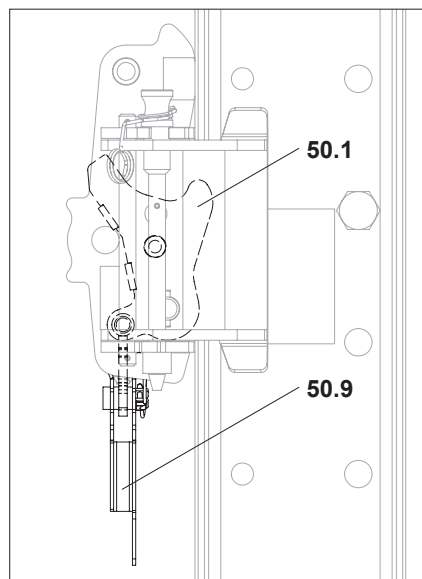

Fig. D5.09a

D5 Operating the climbing shoe (With Climbing Shoe Display RCS)

Activating the climbing pawl

1. Ensure that the climbing unit is stationary.
2. Swing the Climbing Shoe Display RCS (50.9) on the Climbing Shoe RCS (50) upwards.
→ The climbing pawl (50.1) is activated and therefore operational.
(Fig. D5.10 + D5.10a)



- Can the climbing pawl (50.1) move freely?
- Is the Climbing Shoe Display RCS (50.9) suspended horizontally?



This position serves the purpose of transferring vertical forces from the climbing rail during working operations and climbing.

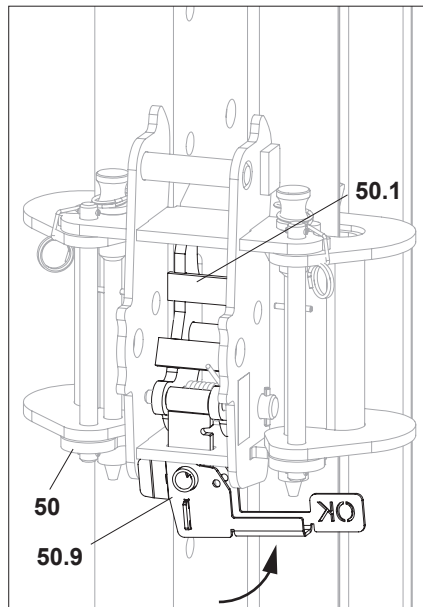

Fig. D5.10

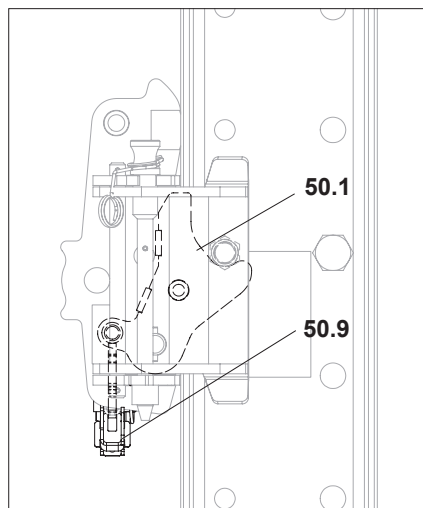

Fig. D5.10a

Safety instructions



Warning

- There is a risk of falling at unsecured building and platform edges!
- As a result of the relocation procedure, falling edges are formed between the platforms!

A fall can result in serious injury or even death.

- ⇒ Guardrails should be installed prior to climbing.
- ⇒ Cordon off areas of risk in advance.
- ⇒ Use personal protective equipment to prevent falling from a height.



Warning

Body parts can become trapped between climbing rails and climbing shoes!

This can result in serious injuries.

- ⇒ Do not hold the climbing shoe and climbing rails when the climbing unit is being moved.



Warning

Incorrect operation or faults in the hydraulic system, e.g. air, can cause the climbing unit to move unexpectedly!

This can result in serious injuries.

- ⇒ Only access the climbing unit if manual intervention is required.
- ⇒ Set the climbing unit down on the climbing shoes before accessing it, ensuring that the load is fully supported.
- ⇒ Consult the operating personnel before accessing the climbing unit.



- The load-bearing capacity of the structural elements, which carry the load-carrying climbing shoes, must be ensured.
- Do not transport persons, building materials or tools when moving with the crane. These could fall off, leading to serious injury or even death.
- Materials or other components must not protrude beyond the building edge. These could hinder the climbing process or fall off.
- No parts of the finishing platform may protrude into the area of the hoses.
- If manual intervention in the climbing process is necessary, the platforms being climbed may only be accessed if they are supported by the climbing shoes in a load-bearing manner. Consult the operating personnel.
- In the event of a malfunction, the climbing unit is to be set down in the next possible position and an authorised person is to be informed immediately!
- Arrange the hydraulic hoses in such a way that
 - loops and knots are prevented,
 - no loops overhang the edge of the platform,
 - they do not get caught on the climbing platforms.
- Up to 2 units can be climbed at the same time.
- Monitor the climbing procedure from a safe position.



The following points are key if the climbing unit is to function perfectly:

- Exact alignment of the anchoring in all 3 axes.
 - Measure the anchoring points precisely (plumb line, chalk line) and fit them securely in their positions.
- Keep the weight of the climbing unit as low as possible.
 - Remove all ballast from the platforms.
 - Do not make climbing units unnecessarily heavy.
- Maintenance status of the climbing shoes and climbing rails.
 - Clean climbing rails regularly and lubricate the sliding section of the climbing shoes. Protect the structure and platform planking from lubricants.
- Optimum condition of the entire hydraulic system.
 - Use hydraulic oil (viscosity) that is suited to the ambient conditions.
 - Use hydraulic lines that are as short as possible.

Hydraulic diagram

See Fig. D6.01.

The arrangement of the plug connectors and bushings of the quick couplers is clearly shown.

Remedial measures for malfunctions

- Uneven cylinder extension and retraction
- Cylinder sinks
- Hydraulic oil is leaking
- Cylinder does not extend

See "Assembly Instructions for the RCS Climbing Device and Hydraulics".

Operating the hydraulic system

See "Assembly Instructions for the RCS Climbing Device and Hydraulics".

Bleeding the hydraulic system

See "Assembly Instructions for the RCS Climbing Device and Hydraulics".

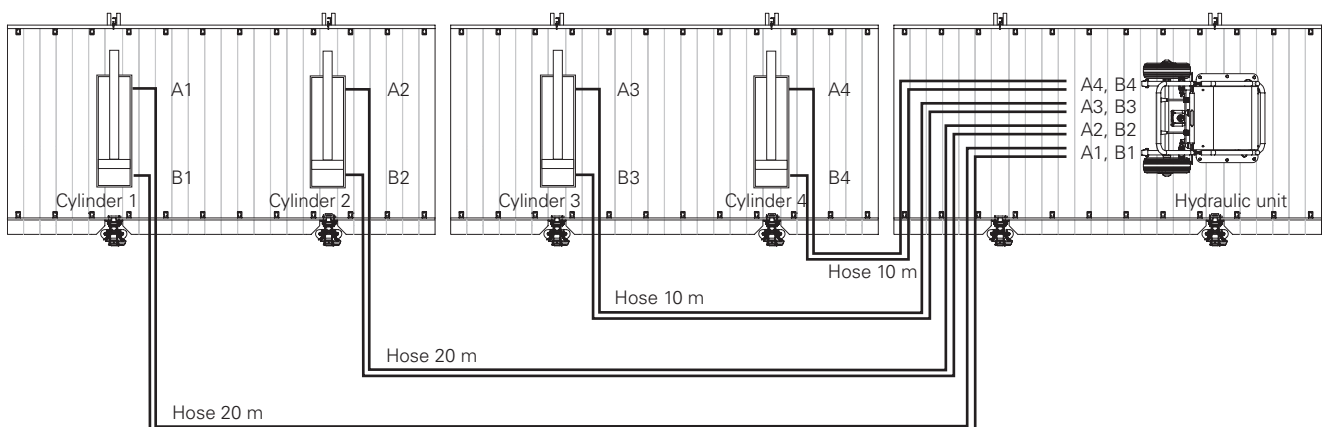

Fig. D6.01

Putting climbing hydraulics into operation

See "Assembly Instructions for the RCS Climbing Device and Hydraulics".

Preparations

The load is resting on the upper climbing shoe.
Self-climbing is carried out from the upper climbing shoes.

The process is controlled from the finishing platform of the adjacent climbing unit. (Fig. D6.01)

Lay the hydraulic hoses on the finishing platform.

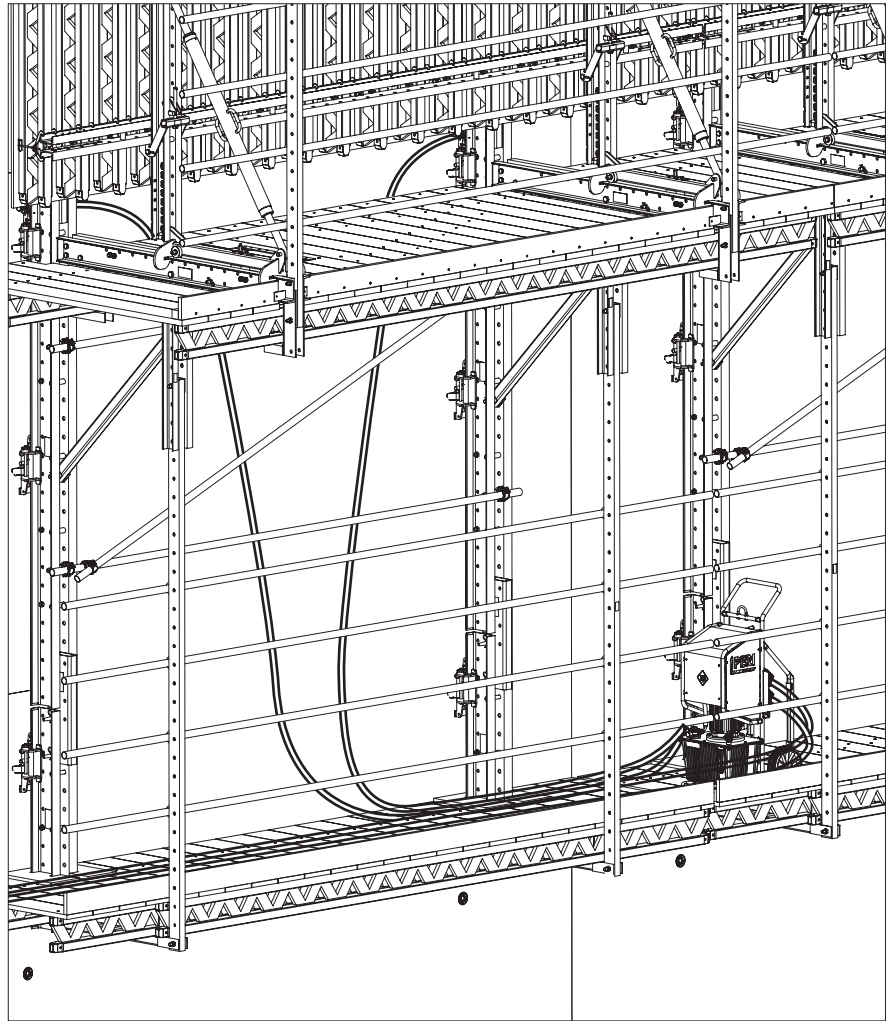

Fig. D6.02

Preparations

Components

- 7** Climbing Rail Extension RCS 125
- 24** Carriage
- 50** Climbing Shoe RCS

The load is resting on the upper climbing shoe (**50c**).

Assembly

1. Undo formwork ties and leading tie fixings. See Section "Releasing the leading tie" on page 104.
2. Remove connections between the climbing units.
3. Retract the carriage (**24**). See Section "Operating the carriage" on page 102.
4. Mount the climbing rail extension (**7**) on the climbing rail with the filler pins and cotter pins supplied.
5. Working from the finishing platform, remove the climbing shoes (**50e**), wall shoes and anchoring, see Section "Dismantling the suspension" on page 107.
6. Fit the wall and climbing shoes on the new concreting section in advance (**50b**), deactivate the climbing pawls and close the guiding skids. (Fig. D6.03)
7. Prepare the climbing hydraulics. See "Assembly Instructions for the RCS Climbing Device and Hydraulics".
8. Pull the hydraulic hoses between the wall and the platforms without creating any loops. If necessary, attach suitable strain relief. (Fig. D6.02)

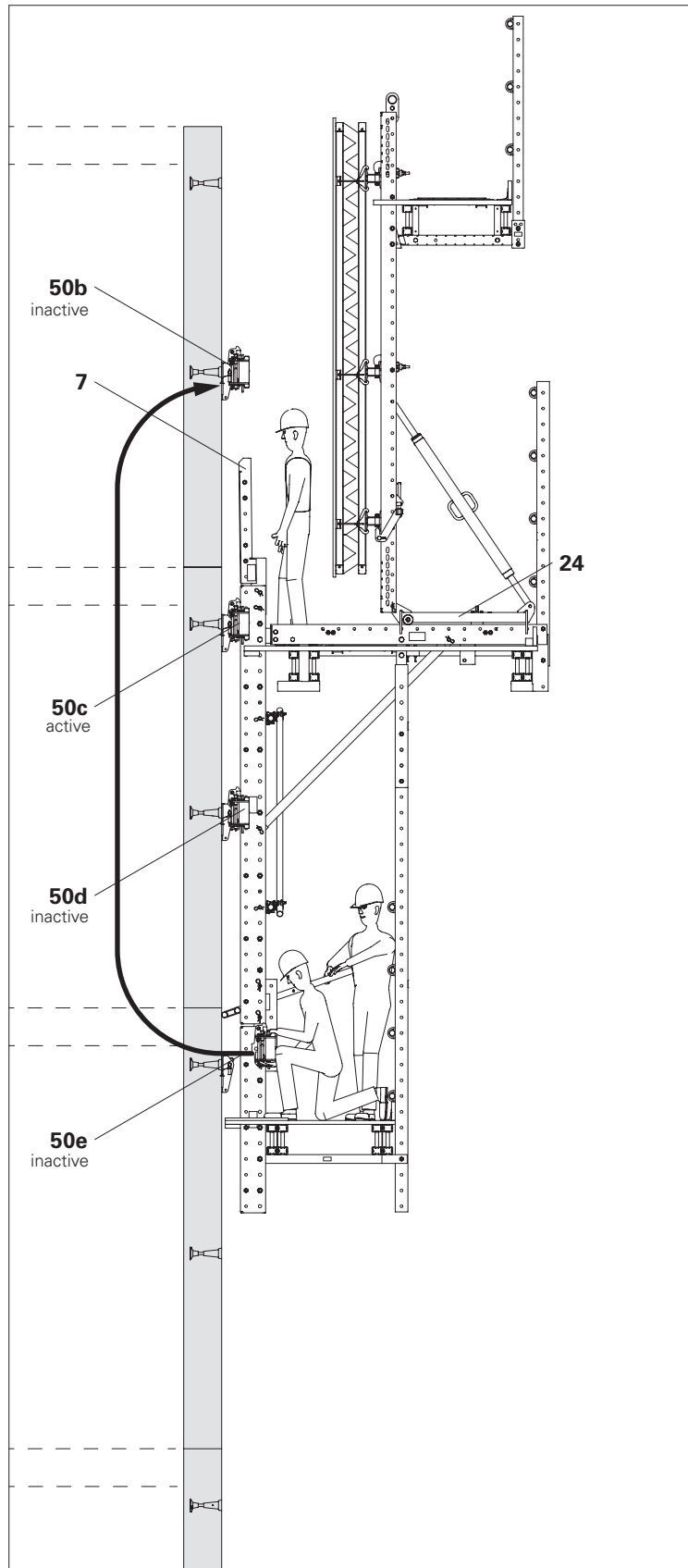

Fig. D6.03

Self-climbing procedure

Components for steps 1– 2

- 3** Spacer M20-82
- 7** Climbing rail extension RCS 125
- 50** Climbing Shoe RCS
- 50.1** Climbing pawl
- 50.6** Bolt
- 60** Climbing Device RCS 50
- 60.1** Claw
- 60.6** Locking lever

Step 1

1. Position the Climbing Device RCS (**60**) on the bolts (**50.6**) of the upper climbing shoes (**50c**) and engage. The climbing device is pressed against the climbing rail through spring force. Guide the claw into the climbing rail.
3. Attach twin hoses to the hydraulic unit and create a short-circuit connection at the other end by coupling them together.
4. Switch on the hydraulic unit and flush the hose for approx. 1 minute by operating the hand valve.
5. Disconnect the hose ends from one another and connect them to the climbing devices (**50**).
6. If necessary, activate the climbing pawls of the upper slab shoes (**50c**) and deactivate the others.
7. Leave the climbing unit.

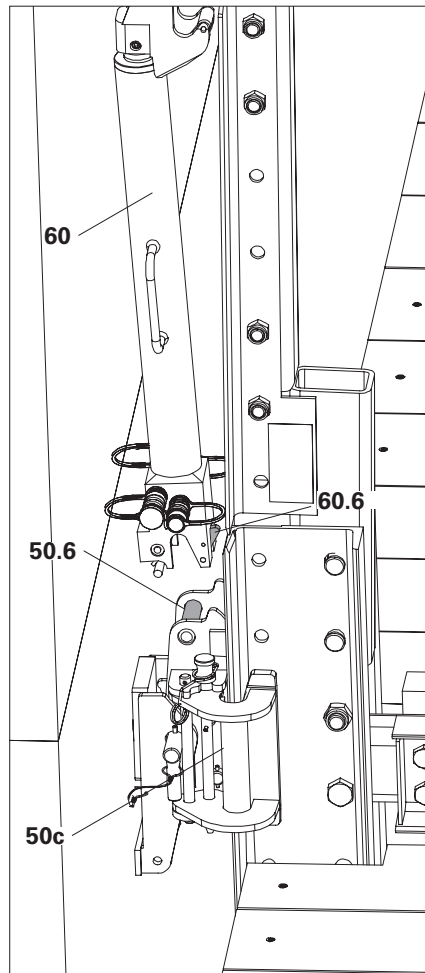

Fig. D6.04

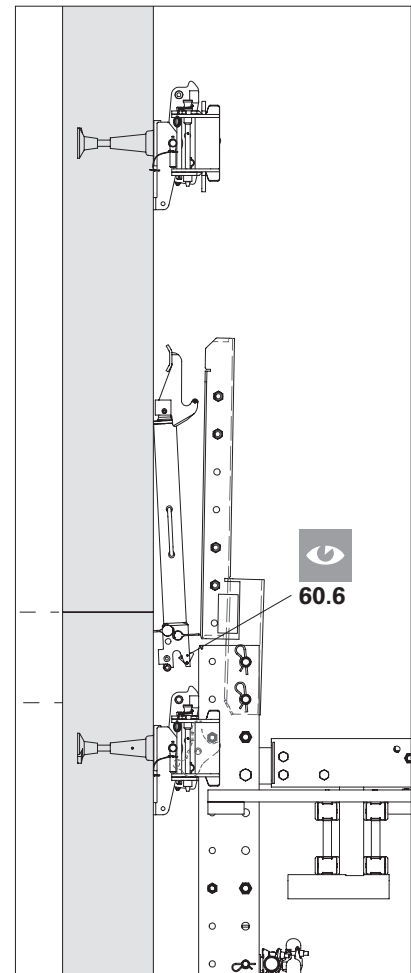

Fig. D6.05



- Is the locking lever (**60.6**) fully engaged on the cylinder base?
- No possibility of the hydraulic hoses becoming entangled?

Step 2

1. Extend the climbing device (**60**) to the first spacer (**3**) of the climbing rail extension.
 2. Load is now carried by the piston with claw (**60.1**).
- (Fig. D6.06)



Are all claws engaged in the spacers?

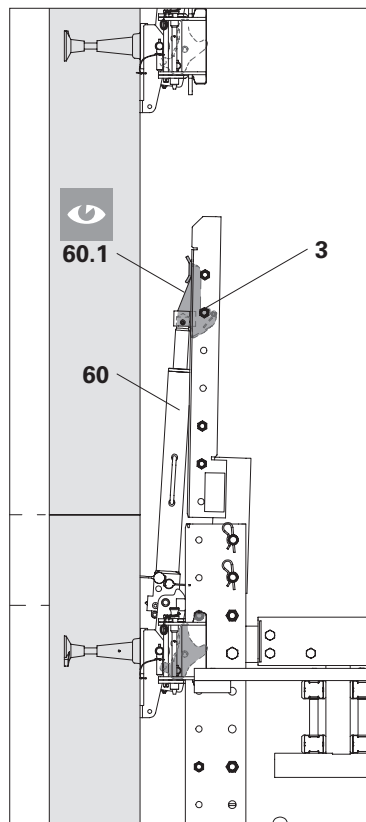

Fig. D6.06

Components for steps 3– 6

- 3** Spacer M20-82
- 7** Climbing rail extension RCS 125
- 50** Climbing Shoe RCS
- 50.1** Climbing pawl
- 60** Climbing Device RCS 50
- 60.1** Claw

Step 3

1. Extend the climbing device (**60**) all the way.
 2. The climbing pawl (**50.1**) in the climbing shoe (**50c**) is pressed inwards by the spacer (**3**) when climbing past, then unfolded again by means of the spring force (audible click).
- (Fig. D6.07 + D6.08)

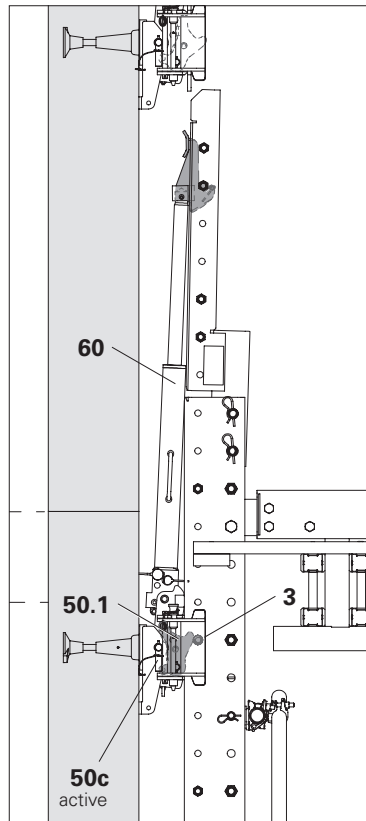

Fig. D6.07

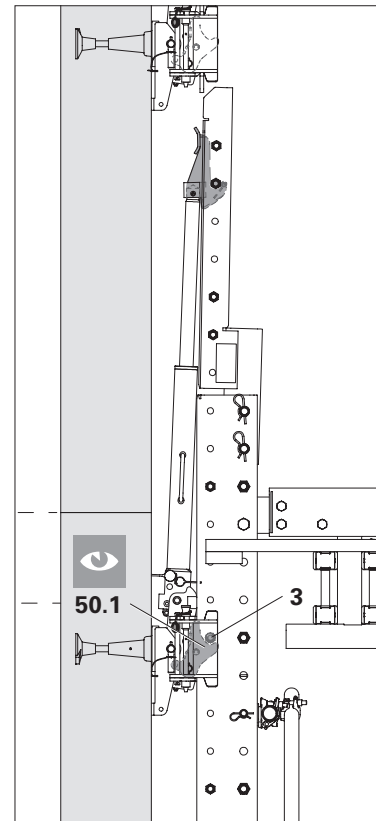

Fig. D6.08



Are the climbing pawls (**50.1**) of all upper slab shoes (**50c**) engaged in the climbing rail? (Fig. D6.08)

If not:

- Extend the climbing device all the way. Due to the end position compensation, the following cylinder moves very slowly.

Step 4

1. Retract all climbing devices until:
 - The spacer (**3**) on the climbing pawl (**50.1**) is mounted in the upper slab shoe (**50c**),
 - The claw is relieved by the spacer (**3a**).
- (Fig. D6.09)

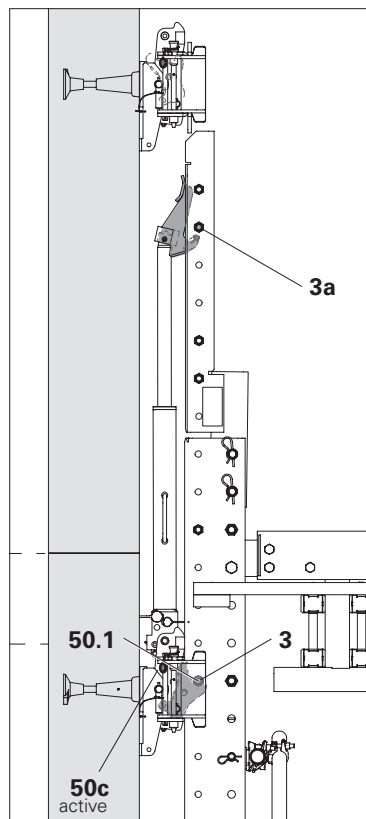

Fig. D6.09

Step 5

1. Retract the climbing device (**60**) until it tilts backwards, the claw (**60.1**) slides past the spacer (**3**) positioned underneath and engages again below.

(Fig. D6.10)



Are all claws under the spacers correctly engaged?

Otherwise press down by hand.

If necessary, further retract the hydraulic cylinder.

Check the spring in the climbing device base.

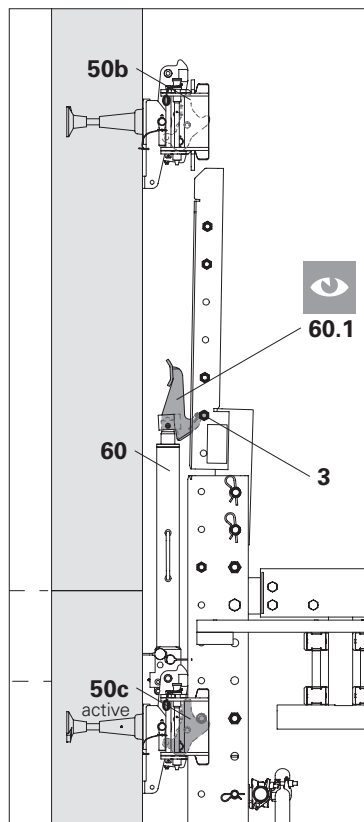

Fig. D6.10

Step 6

1. Extend the climbing device (**60**).
→ The claw (**60.1**) grips onto the spacer (**3**) and lifts the climbing rail.
2. By repeating steps 3 to 6 several times, the climbing unit is gradually climbed upwards in increments of 50 cm.

(Fig. D6.11)



If the hydraulic hoses become taut or entangled, immediately stop the climbing procedure and eliminate the problem.

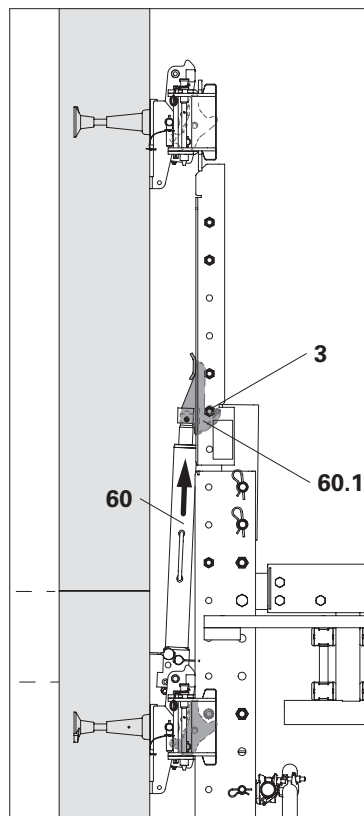

Fig. D6.11

Components for steps 7– 9

- 7 Climbing rail extension RCS 125
- 50 Climbing Shoe RCS
- 50.1 Climbing pawl
- 50.2 Guiding skid

Step 7

Once the climbing shoe in advance (50b) is reached:

1. If this has not already taken place: Interrupt the climbing process and close the guiding skids (50.2) of the climbing shoe in advance (50b), deactivate the climbing pawl (50.1).
2. Continue climbing until the climbing rail extension (7) threads into the climbing shoe (50b).
(Fig. D6.12 + D6.13)



Watch the threading process. In the event of jamming, stop the climbing procedure and guide the climbing rail extension with pry bars.

3. Continue the climbing procedure.

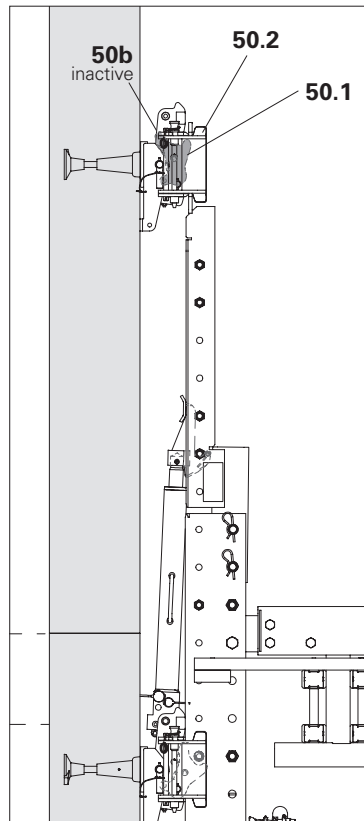

Fig. D6.12

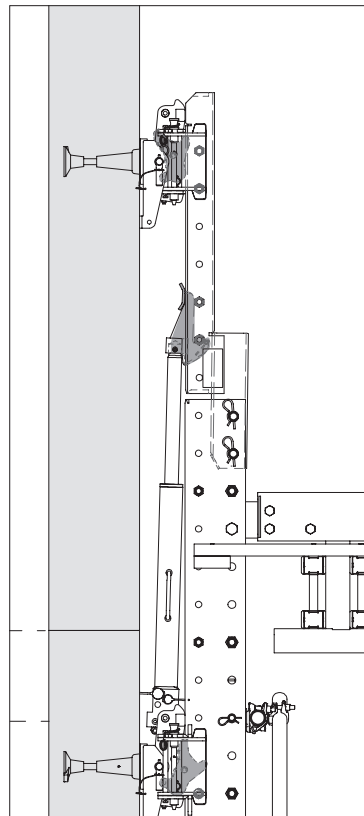

Fig. D6.13

Step 8

Once the climbing shoe in advance (50a) is reached: (Fig. D6.14)

1. Stop the climbing procedure.
2. Working from the finishing platform, remove the climbing shoes (50d) – not shown – wall shoes and anchoring, see Section “Dismantling the suspension” on page 107.
3. If this has not already taken place: Close the guiding skids of the climbing shoe in advance (50a). If the uppermost climbing shoe (50a) is the one intended for the vertical load, activate the climbing pawl there.
4. Continue climbing until the climbing rail extension (7) threads into the climbing shoe. (Fig. D6.15)



Watch the threading process. In the event of jamming, stop the climbing procedure and guide the climbing rail extension with pry bars.

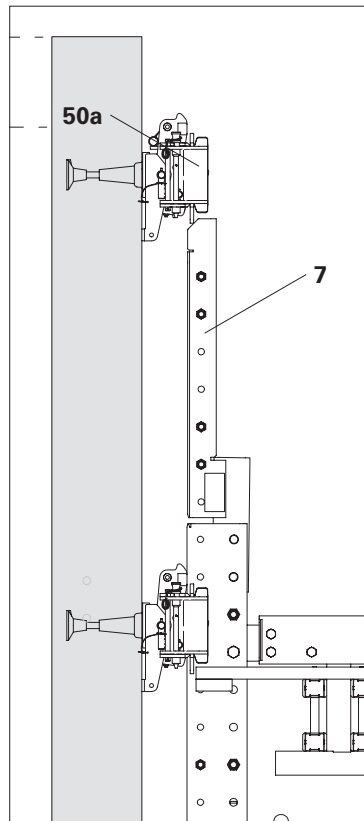

Fig. D6.14

Step 9

1. Continue the climbing procedure.
2. Interrupt the final stroke after approx. 10 cm
3. Activate the climbing pawl on the climbing shoe (50a) that is earmarked to take the vertical load.
4. Deactivate the climbing pawl on the climbing shoe that is carrying the climbing device (50c).

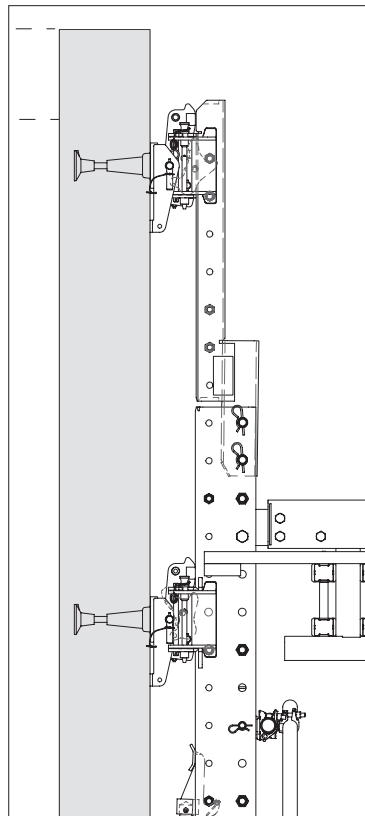

Fig. D6.15

Components for steps 10– 11

- 3** Spacer M20-82
- 7** Climbing rail extension RCS 125
- 50** Climbing Shoe RCS
- 60** Climbing Device RCS 50
- 60.1** Claw
- 60.6** Locking lever

Step 10

1. Lift the climbing unit into the end position until the activated climbing pawl (**50.1**) engages beneath the intended spacer (**3**).
2. Retract the climbing device until:
 - The load is carried by the climbing pawl (**50.1**) in the earmarked slab shoe (**50a**).
 - The claw (**60.1**) is released from the spacer (**3**).

(Fig. D6.16)



Is the climbing unit resting on both sides of the climbing pawls (**50.1**) of the earmarked climbing shoes (**50a**)?
If not:

- Raise the climbing unit with the climbing device by a few centimetres.
- Deactivate the climbing pawls of all other climbing shoes (**50b + 50c**).
- Lower the climbing unit until the spacers are fully load-bearing on the climbing pawls of the upper slab shoes (**50a**).

3. Retract the climbing device all the way.

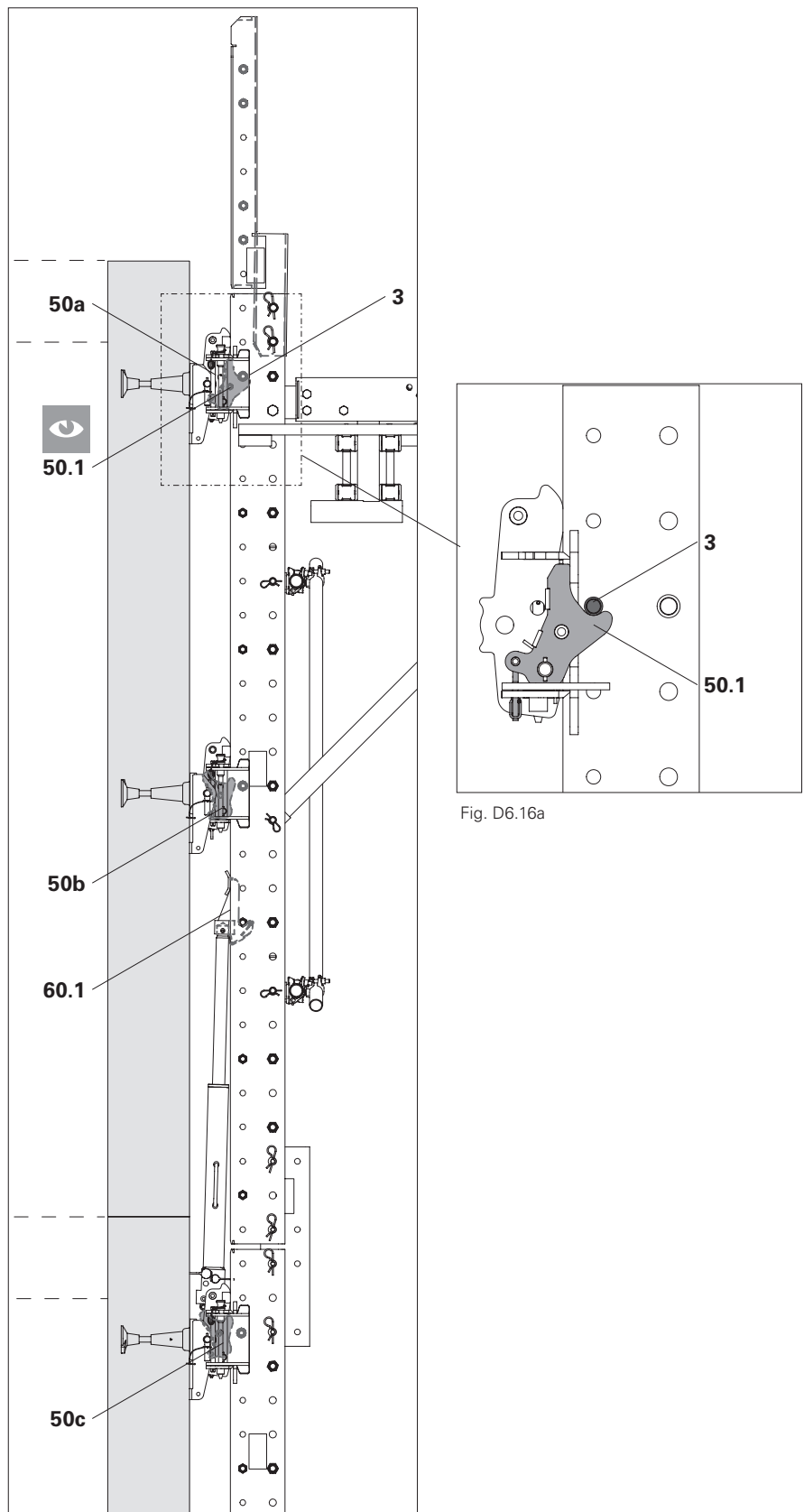

Fig. D6.16a

Fig. D6.16

Step 11

1. Remove the climbing rail extension (7) from the upper end of the climbing rail (1).
2. Detach hydraulic hoses from the climbing device using the quick couplers.
3. Tilt the climbing device backwards, operate the locking lever (60.6) on the cylinder base and lift out the climbing device. (Fig. D6.17 + D6.17a)
4. Transport the hydraulic unit, climbing device and hydraulic hoses to the next climbing unit.



In order to prevent the locking lever immediately engaging again after releasing, press the climbing device slightly to the side.



When the hydraulic cylinders are not in use, always retract the pistons completely.

Concluding work

1. Complete or reinstate the guardrail.
2. Reinstall the covers and connections between the platforms of the climbing units.

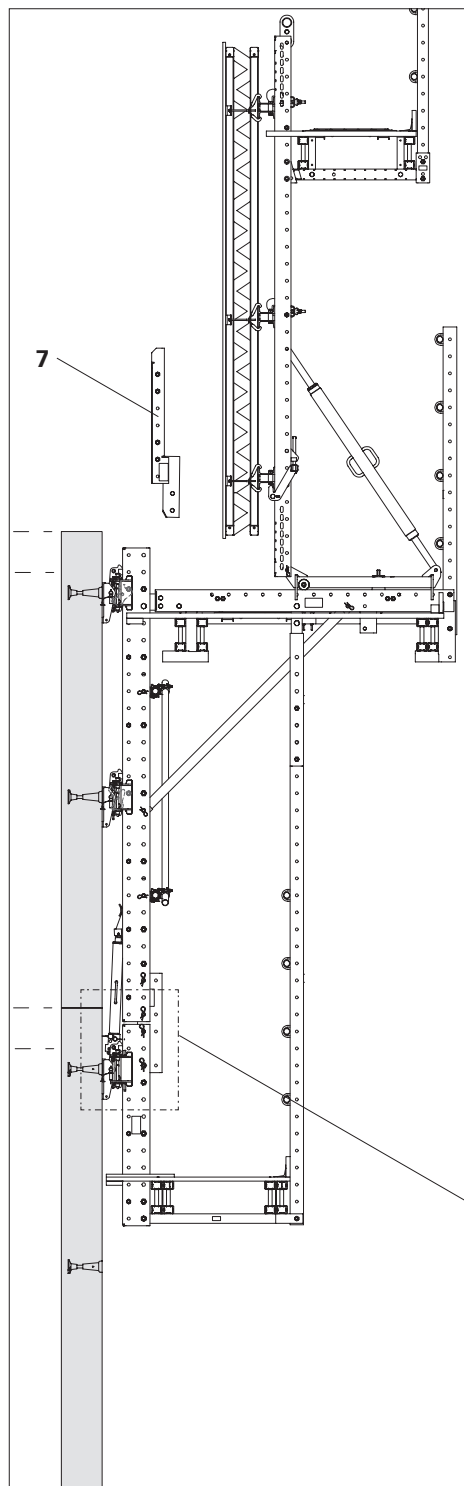

Fig. D6.17

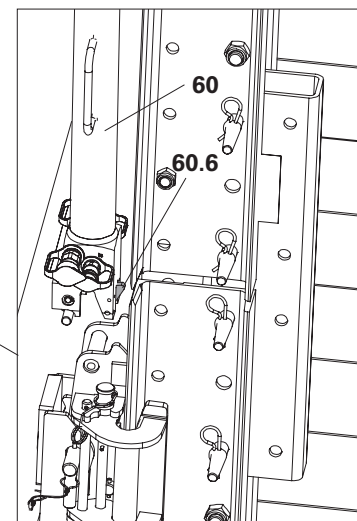

Fig. D6.17a

Self-climbing the final unit

The hydraulic unit is placed on the finishing platform of the climbing unit.

- Only climb one unit at a time so that the hydraulic hoses do not get tangled.
- Keep an eye on the hydraulic hoses during the climbing process.

(Fig. D6.18)



- If the hydraulic hoses become taut or entangled, stop the climbing procedure and eliminate the problem!
- After climbing the final unit, move the climbing devices one storey upwards.
- Store all hydraulic equipment until the next application, protected against dirt and damage.

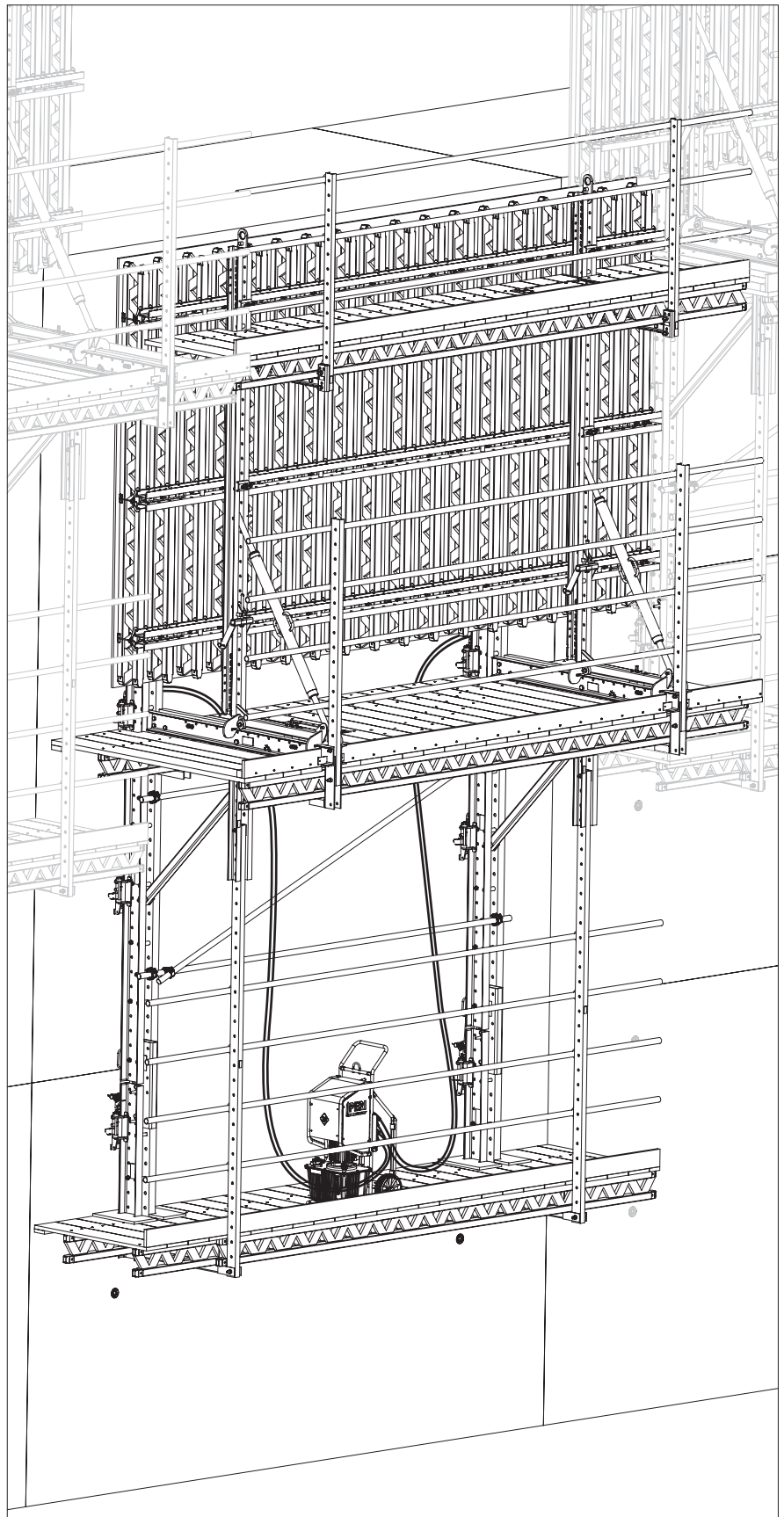

Fig. D6.18

Safety instructions



Warning

- There is a risk of falling from unsecured building edges!
 - As a result of the relocation procedure, falling edges are formed between the platforms!
- A fall can result in serious injury or even death!
- ⇒ Guardrails must be installed prior to climbing.
 - ⇒ Cordon off areas of risk in advance.
 - ⇒ Use personal protective equipment to prevent falling from a height.



Warning

- Body parts can become trapped between climbing rails and climbing shoes!
- This can result in serious injuries.
- ⇒ Do not hold the climbing shoes and climbing rails when the climbing formwork is being moved.



Warning

- Climbing with a crane can lead to unexpected movements in the climbing unit, e.g. due to incorrect operation!
- This can result in serious injuries.
- ⇒ Only access the climbing unit if manual intervention is required.
 - ⇒ Set the climbing unit down on the climbing shoes before accessing it, ensuring that the load is fully supported.
 - ⇒ Before accessing the climbing unit, consult the operating and crane personnel.



- The load-bearing capacity of the structural elements, which carry the load-carrying climbing shoes, must be ensured.
- Do not transport persons, building materials or tools when moving with the crane. These could fall off, leading to serious injury or even death.
- Materials or other components must not protrude beyond the building edge. These could hinder the climbing process or fall off.
- In the event of a malfunction, the climbing unit should be set down in the next available position and an authorised person should be informed immediately.
- When climbing by crane, always provide safe access for attaching and detaching the crane lifting gear. Additional two-sling lifting gear that remains on the climbing formwork may be necessary until it can be safely removed.



The following points are key if the climbing unit is to function perfectly:

- Exact alignment of the anchoring in all 3 axes.
 - Measure the anchoring points precisely (plumb line, chalk line) and fit them securely in their positions.
- Keep the weight of the climbing unit as low as possible.
 - Remove all ballast from the platforms.
 - Do not make climbing units unnecessarily heavy.
- Maintenance status of the climbing shoes and climbing rails.
 - Clean and grease climbing rails regularly.

Preparations

Components

- 1** Upper Climbing Rail RCS
- 24** Carriage
- 50** Climbing Shoe RCS

The load is resting on the upper climbing shoe (**50c**).

Assembly

1. Undo formwork ties and leading tie fixings. See Section "Releasing the leading tie" on page 104.
2. Remove connections between the climbing units.
3. Retract the carriage (**24**). See Section "Operating the carriage" on page 102.
4. Working from the finishing platform, remove the climbing shoes (**50e**), wall shoes and anchoring, see Section "Dismantling the suspension" on page 107.
5. Fit the wall and climbing shoes on the new concreting section in advance. (**50b**)
6. Activate the climbing pawl on the climbing shoe in advance (**50b**) and close the guiding skids.
7. From a safe position, attach the crane lifting gear to the upper climbing rail (**1**), then leave the climbing unit and the danger zone.

(Fig. D7.01)

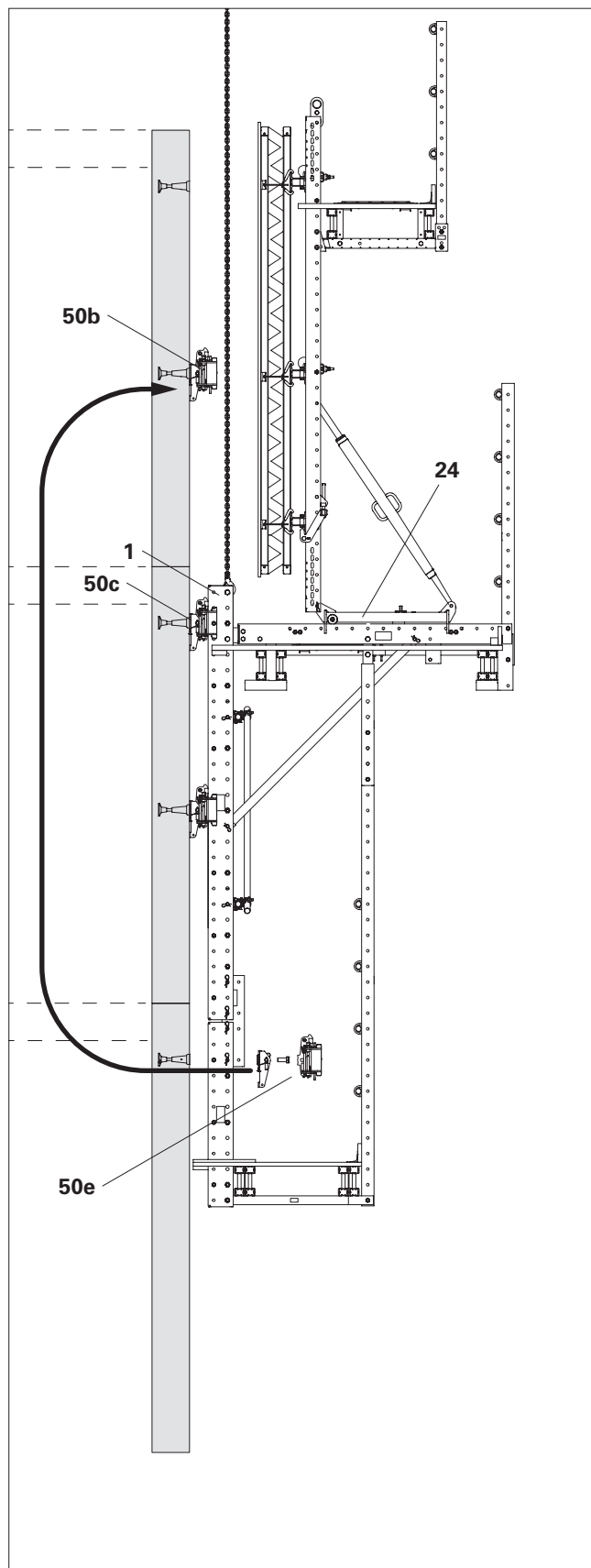

Fig. D7.01

Moving procedure

Components

- 3** Spacer
- 25** Strongback
- 50** Climbing Shoe RCS
- 50.1** Climbing pawl

Step 1

1. Slowly lift the climbing unit into the next climbing shoes (**50b**) with the crane until the climbing pawls (**50.1**) of the climbing shoes (**50b**) audibly engage with the earmarked spacers (**3**). (Fig. D7.02 + D7.02a)
2. Set the climbing unit down on the climbing shoes (**50b**) ensuring that the load is fully supported, and stop the climbing process.



Is the climbing unit resting on both sides of the climbing pawls (**50.1**) of the climbing shoes (**50b**)? (Fig. D7.03)

If not:

1. Raise the climbing unit by a few centimetres with the crane.
2. Deactivate the climbing pawls of all other climbing shoes.
3. Lower the climbing unit until the spacers are resting on the climbing pawls of the slab shoes (**50b**) in a fully load-bearing manner.

Step 2

1. Enter the platform and remove the climbing shoes (**50d**), wall shoes and anchoring from the finishing platform.
2. Fit the recovered climbing shoe as a leading climbing shoe (**50a**).
3. Leave the climbing unit and danger zone and continue the climbing procedure.

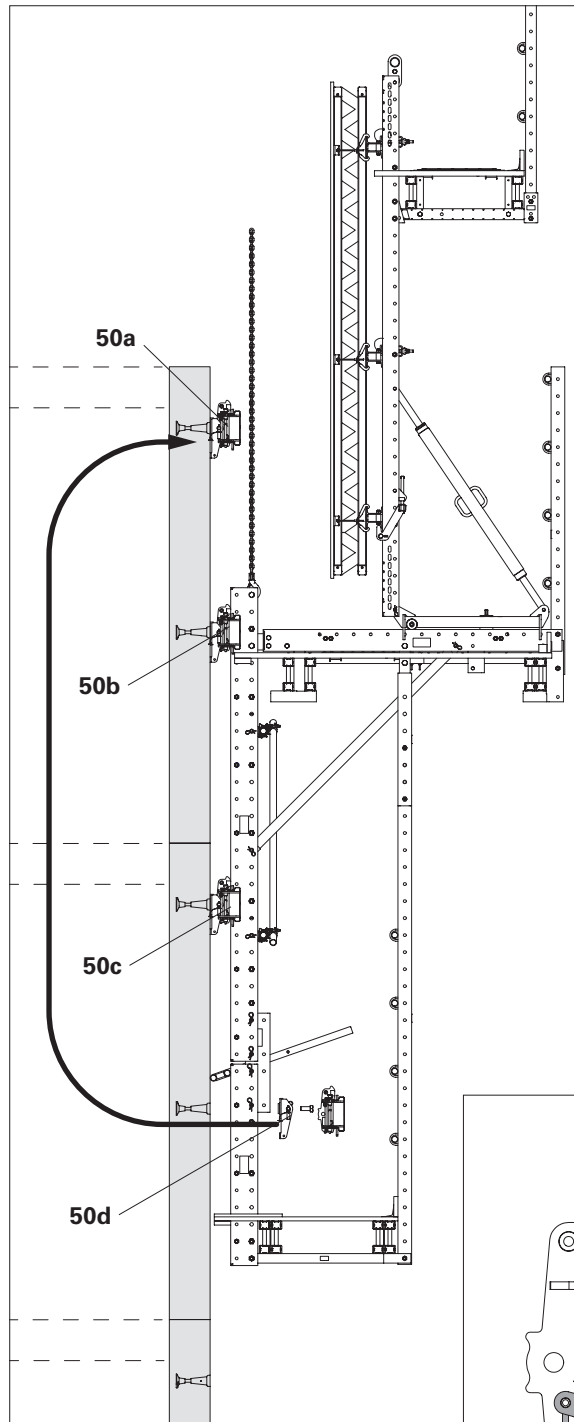

Fig. D7.02

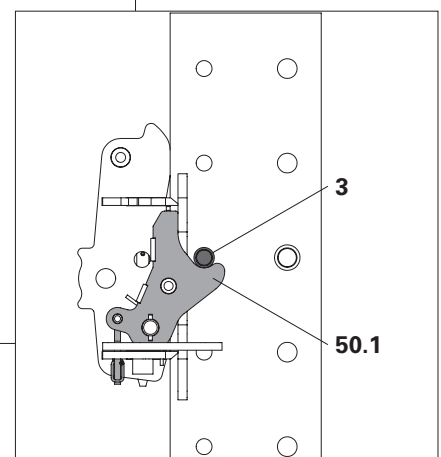

Fig. D7.02a

Step 3

1. Slowly lift the climbing unit into the next climbing shoes (50a) with the crane until the climbing pawls (50.1) of the climbing shoes (50a) audibly engage with the earmarked spacers (3).
2. Set the climbing unit down on the climbing shoes (50a), ensuring that the load is fully supported.



Is the climbing unit resting on both sides of the climbing pawls (50.1) of the climbing shoes (50a)? (Fig. D7.03)
If not:

1. Raise the climbing unit by a few centimetres with the crane.
2. Deactivate the climbing pawls of all other climbing shoes.
3. Lower the climbing unit until the spacers are resting on the climbing pawls of the slab shoes (50a) in a fully load-bearing manner.

Step 4

1. Enter the climbing unit and knock the crane lifting gear off the strongback.
2. Add connections between the climbing units.

For operation of the climbing shoes, see Section "D5 Operating the climbing shoe" on page 110.

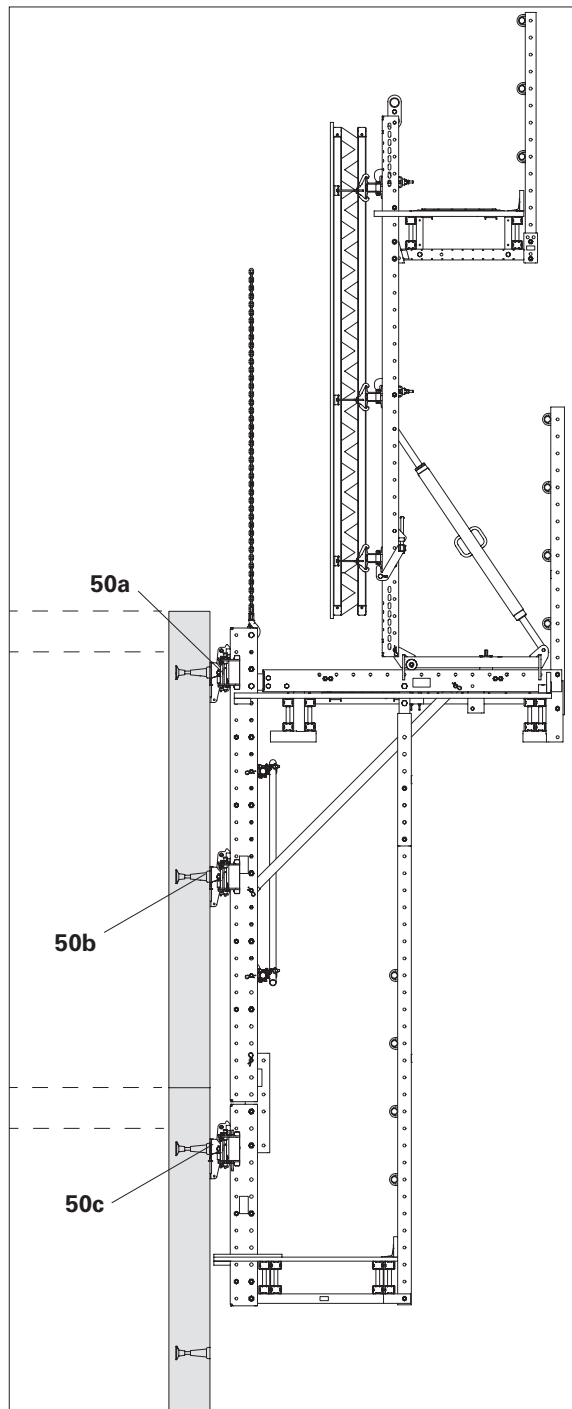

Fig. D7.03



Warning!

Unsecured lateral fall edges! A fall can result in serious injuries or even death.

⇒ Use PPE when attaching and detaching the crane lifting gear.



- Particularly in the case of enclosed climbing formwork, changes to the centre of gravity position can cause the climbing shoes to jam.
- The centre of gravity depends on the individual components used.

1. Adjust the carriage (24) in such a way that the strongback (25) is positioned as close as possible above the centre of gravity of the entire climbing formwork.
2. Attach crane lifting gear to the strongback (25).

(Fig. B7.04)

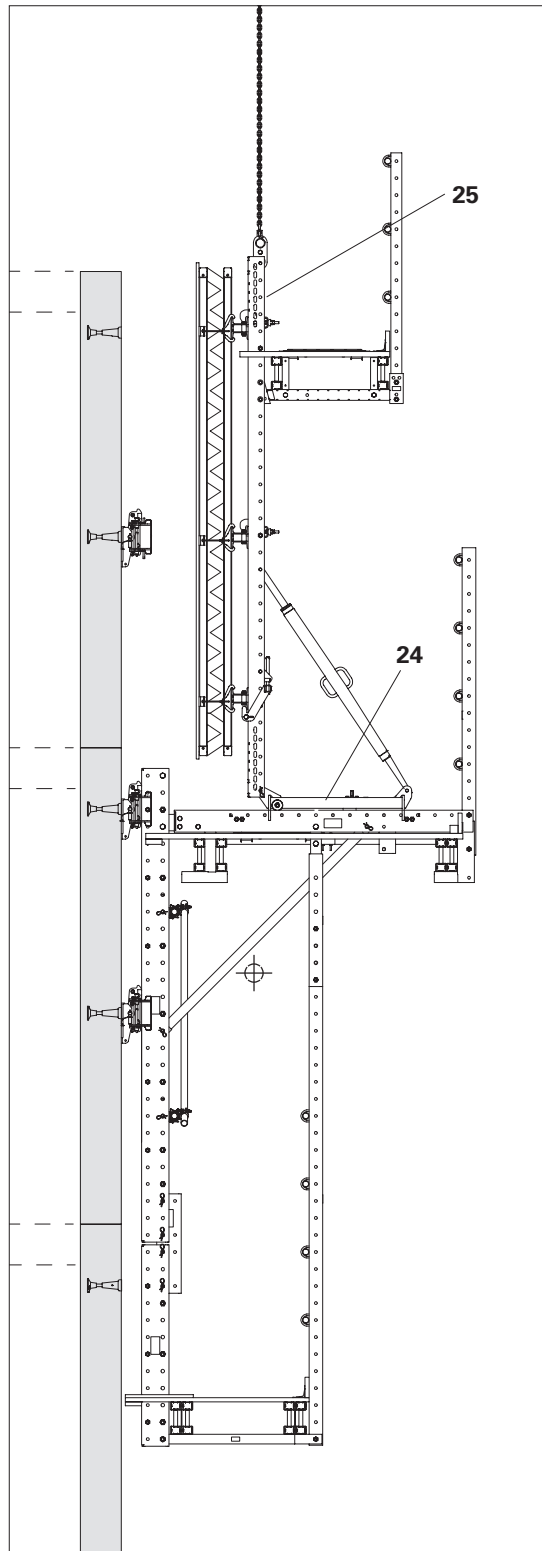

Fig. D7.04

If climbed too far



Climbing back is only permitted with a crane!

1. Deactivate the pawls of the climbing shoes (**50b + 50c**). Fit the pawl locks of the climbing shoes (**50a**) with sufficiently long ropes.
2. Leave the climbing unit and the danger zone.
3. Raise the climbing unit by approx. 10 cm using the crane.
4. From a safe position, pull the pawl locks of the upper climbing shoes (**50a**) with the rope and maintain that tension.
5. Lower the climbing unit with the crane until the correct spacer is approx. 10 cm above, then pull the rope and release the pawl locks.
6. Set the climbing unit down on the upper climbing shoes (**50a**) to support the load. Remove the ropes.



For operation of the climbing shoes, see Section "D5 Operating the climbing shoe" on page 110.

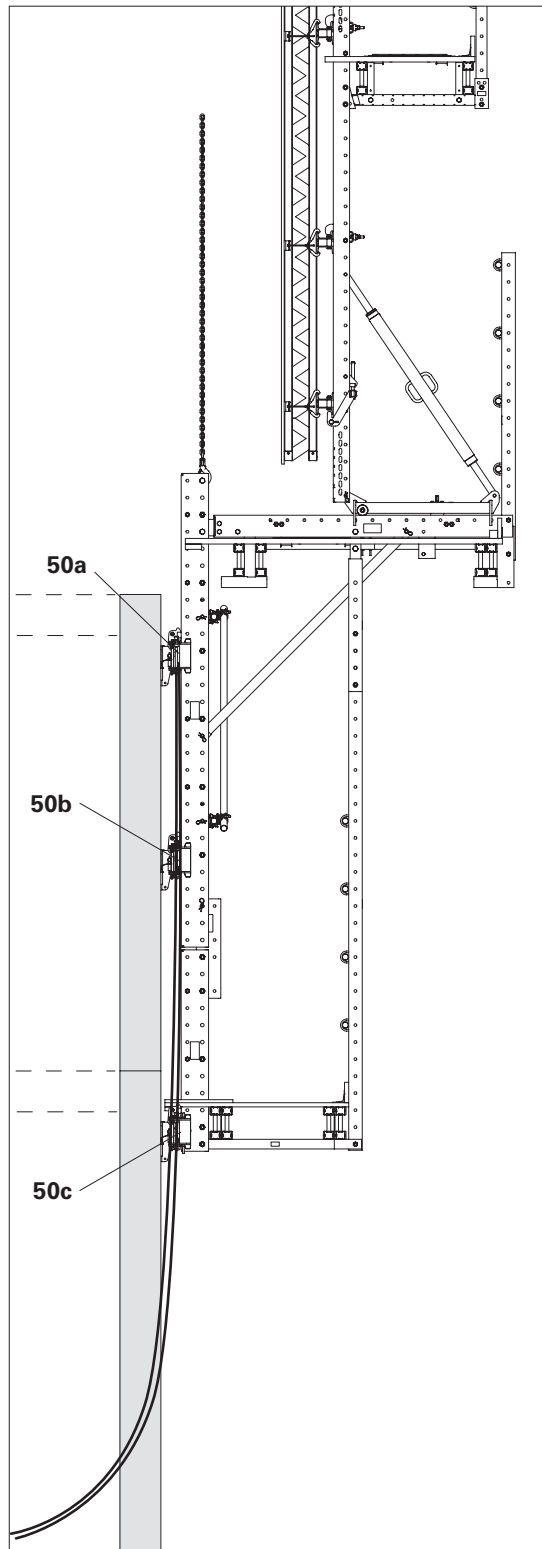

Fig. D7.05

General



Warning

- Risk of falling from unsecured building edges and climbing units!
A fall can result in serious injury or even death.
⇒ Install guardrails.
⇒ Use personal protective equipment to prevent falling from a height (PPE).
- During assembly on the construction site, components may fall to the ground and hit people below!
This can lead to serious injuries or even death.
⇒ Remove or secure all loose parts.
⇒ Cordon off danger zones beneath the working areas.

Dismantling formwork

Components

- 24** Carriage RCS
25 Steel Waler Universal SRU L = 2.72
28 Heavy Duty Spindle SLS 200/300

Disassembly

1. Remove the formwork and retract the carriage (**24**).
2. Attach crane lifting gear to the head of the strongback (**25**) and tighten with the crane.
3. Remove the bolts from the formwork spindle (**28**) and the strongback (**25**) on the carriage.
4. Lift away the formwork, set it down at a suitable assembly site and dismantle it.

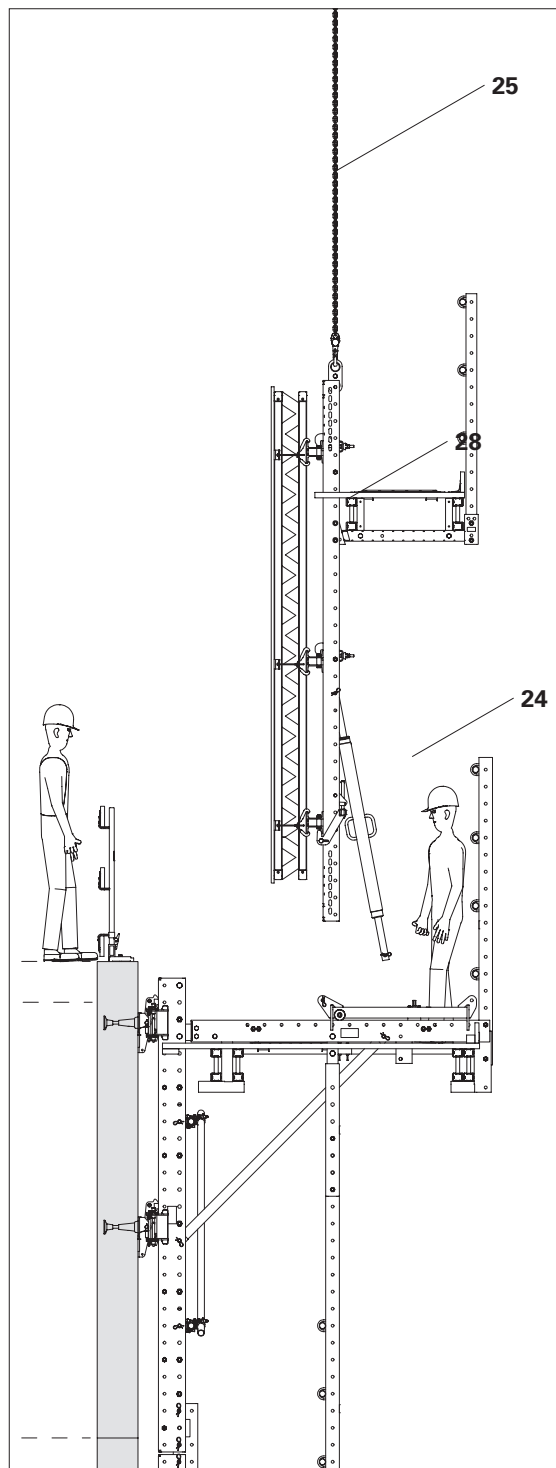

Fig. E1.01

Lifting out the climbing unit

Requirements

The vertical load is resting on the upper climbing shoe (50a).

Otherwise, activate the climbing pawl of the uppermost climbing shoe (50a) and set the climbing unit down on the uppermost climbing shoe, ensuring that the load is supported.

If necessary, deactivate the climbing pawl of the middle climbing shoe (50b).

Components

24 Carriage RCS

79 Guardrail Post U100 225 RCS

50 Climbing Shoe RCS

Disassembly

1. Working from the finishing platform, remove the climbing shoes (50c), wall shoes and anchoring.
2. Remove or brace the lateral protection (79) of the work platform. See Section "C2 Pre-assembling the console bracket unit" on page 74. (Fig. E1.02)

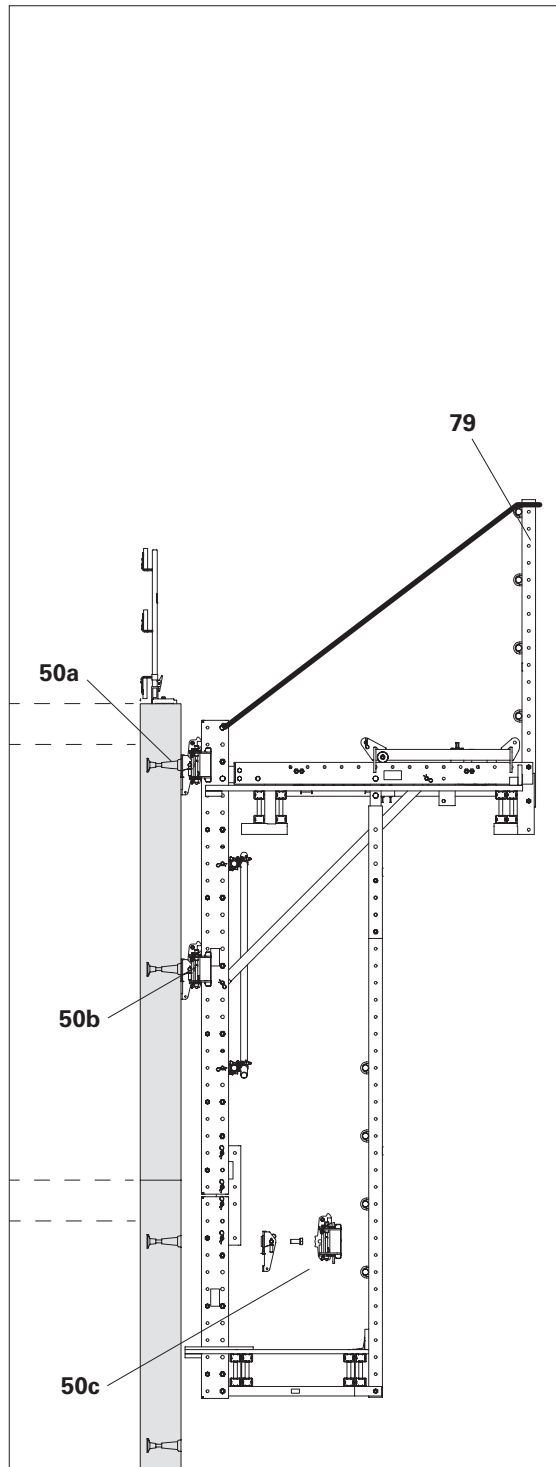

Fig. E1.02

3. Move the carriage (24) over the centre of gravity of the climbing unit.
4. Attach the climbing unit to the carriage with filler pins 4x 21 x 120, tighten the crane lifting gear.
5. Open the guiding skids of the climbing shoe (50b).
6. Leave the climbing unit and the danger zone.
7. Lift the climbing unit upwards and out of the climbing shoes.
8. Lift away the climbing unit and dismantle it at a suitable assembly site.
9. Secure the remaining climbing shoes (50b) + (50a), wall shoes and anchoring to prevent them from falling down and have them removed by safeguarded personnel.

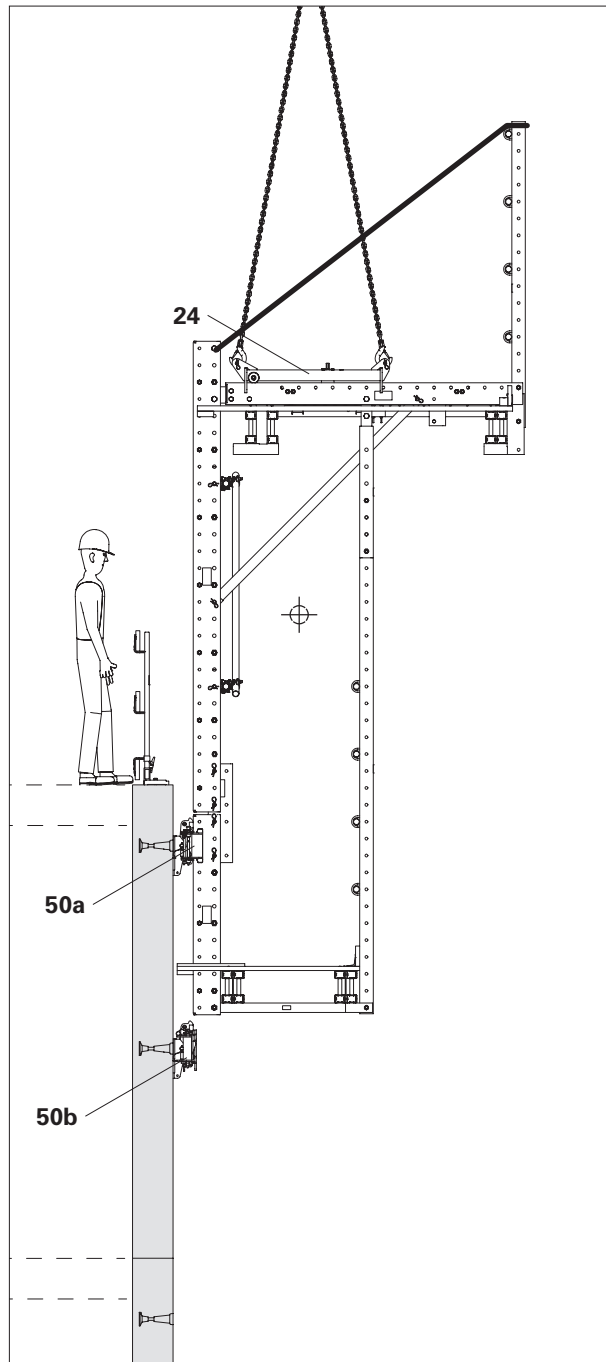

Fig. E1.03

Removing the climbing unit



Warning

Heavy components at risk of falling down!

Body parts can get trapped, resulting in injuries.

- ⇒ Do not linger in the danger zone.
- ⇒ Do not reach into pinch points.
- ⇒ Attach the components being removed to the crane and tighten the crane lifting gear.
- ⇒ Secure components to prevent them from falling.

Disassembly

1. Secure the finishing platform (33) to prevent it from tipping over.
2. Remove scaffolding tubes (88) and guardrail posts (79) (81). (Fig. E2.01)
Alternatively: Lift the entire ladder cage to the side with a crane and dismantle it separately. (Fig. E2.02)

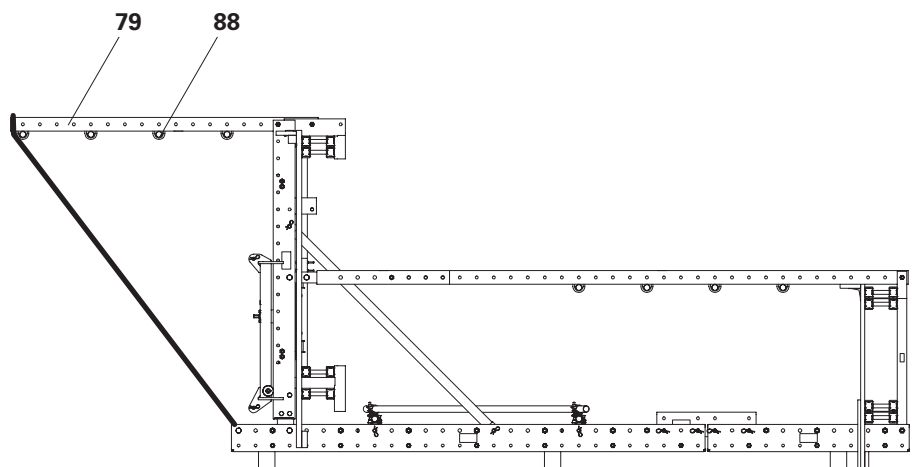

Fig. E2.01

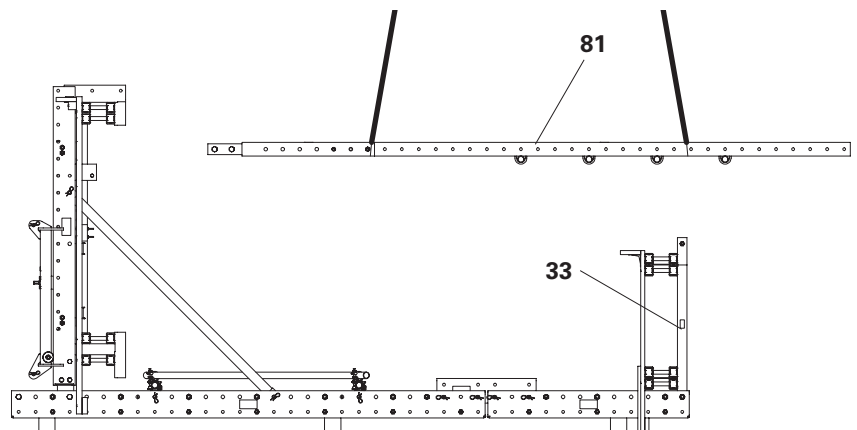

Fig. E2.02

3. Attach the finishing platform (**33**) to the crane, tighten the crane lifting gear.
4. Release the screw connection between the finishing platform beam and the climbing rail and lift the finishing platform to one side with a crane for dismantling. (Fig. E2.03)
5. Attach the work platform (**30**) to the crane, extend the crane lifting gear.
6. Remove the diagonal strut (**11**).
7. Remove the screw connection (**21.1**) between the crossbeam unit (**21**) and the climbing rail (**1**) and lift the work platform to one side for dismantling.



To dismantle the individual modules, see the respective sections on assembly.

Disassembly is carried out analogously in reverse order.

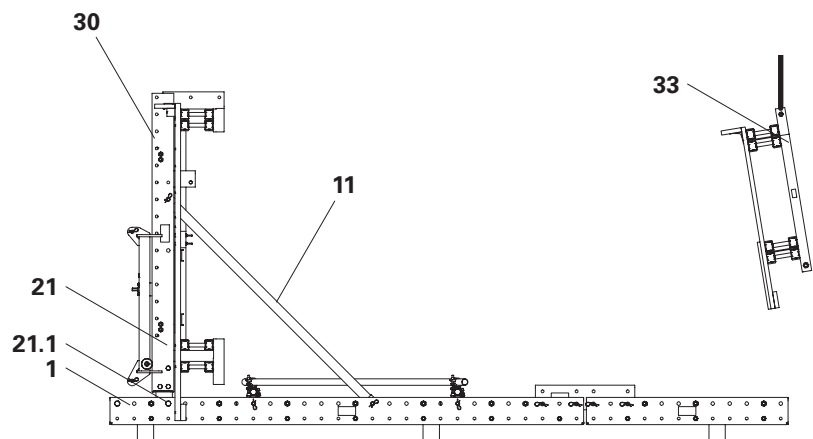

Fig. E2.03

RCS-CL Lightweight Climbing Formwork

Art no.	Weight [kg]		L [mm]
		Climbing Rail RCS	
114166	78.200	CLIMBING RAIL RCS 148	1480
109470	182.000	CLIMBING RAIL RCS 348	3480

Steel profile for all-purpose use in climbing applications or civil construction. With spacers M20-82 and M24-82.

Notes

Wy = 357.6 cm³, ly = 3,576 cm .

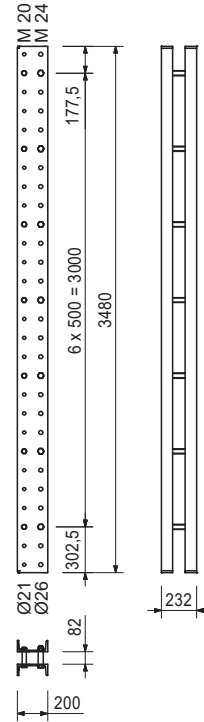

Accessory (not included)

136109	0.472	PIN SET RCS MAX
--------	-------	------------------------

Art no.	Weight [kg]	
110022	0.491	SPACER M20-82

Spacer for Climbing Rails RCS.

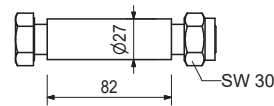
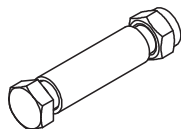

Consists of

1 pc 104477 bolt ISO 4014 M20 x 120-8.8, galv. 1 pc 130341 groove ISO 7042 M20-8, galv.

Art no.	Weight [kg]	
110023	0.910	SPACER M24-82

Spacer for Climbing Rails RCS.

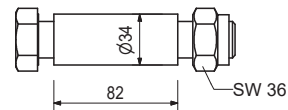
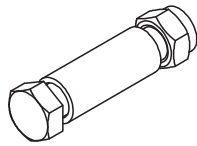

Consists of

1 pc 109612 bolt ISO 4014 M24 x 130-8.8, galv. 1 pc 130342 groove ISO 7042 M24-8, galv.

Art no.	Weight [kg]	
113744	21.000	CLIMBING RAIL CONNECTOR RCS 73

For rigid connection of Climbing Rails RCS. Perm. bending moment limited.

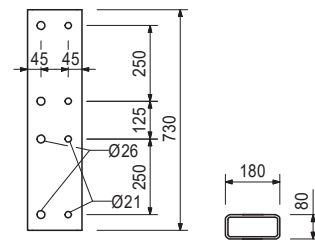

Accessory (not included)

104031	0.462	FILLER PIN D=21X120
018060	0.014	Cotter pin 4/1, galv.
111567	0.729	PIN D=26X120
022230	0.033	COTTER PIN 5/1, GALV.

Art no.	Weight [kg]	
109791	25.900	CLIMB. RAIL EXTENSION 100 RCS

As extension of the Climbing Rail RCS for connecting the finishing platform.

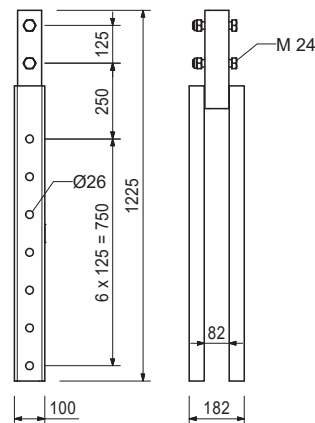

Consists of

2 pc 109612 bolt ISO 4014 M24 x 130-8.8, galv. 2 pc 105032 groove ISO 7040 M24-8, galv.

RCS-CL Lightweight Climbing Formwork

Art no.	Weight [kg]	
114301	17.100	PLATFORM BEAM RCS/SRU 113

For assembling cantilevered platforms on Steel Walers SRU or Climbing Rails RCS.

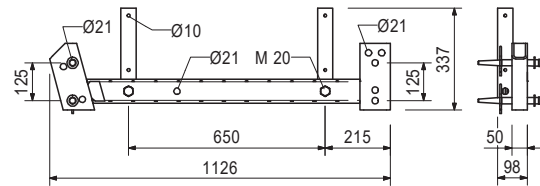
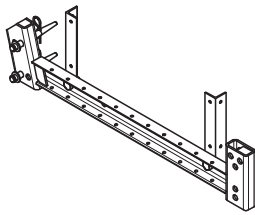

Accessory (not included)

114328	16.600	HANDRAIL POST RCS/SRU 184
--------	--------	----------------------------------

Consists of

- 2 pc 022230 Cotter Pin 5/1, galv.
- 2 pc 104031 Fitting Pin Ø 21 x 120
- 2 pc 706454 Washer ISO 7089 200 HV, A 20, galv.
- 2 pc 706458 Bolt ISO 017 M20 x 40-8.8, galv.
- 2 pc 781053 Nut ISO 7040 M20-8, galv.

Art no.	Weight [kg]	
115325	16.600	STRONGBACK ADAPTER RCS/SRU

For mounting the Strongback SRU to the Carriage RCS when used with TRIO.

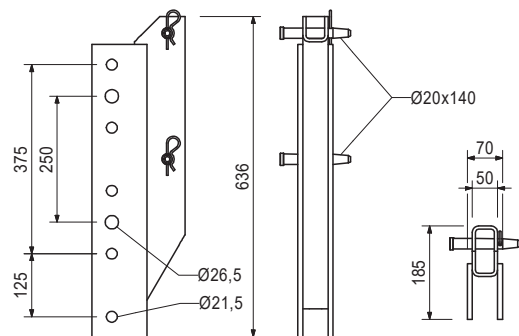
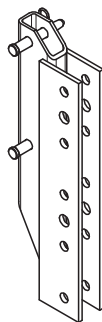

Consists of

- 2 pc 105400 Pin Ø 20 x 140, galv.
- 2 pc 018060 Cotter Pin 4/1, galv.

Art no.	Weight [kg]	
029450	0.339	ADVANCING SCREW M 30, GALV.

For fixing the M30 Anchor System if the plywood formlining is drilled through.

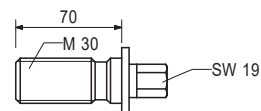
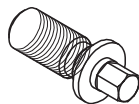

Accessory (not included)

029380	0.184	ANCHOR POSIT. PLATE 20, GALV.
--------	-------	--------------------------------------

Art no.	Weight [kg]	
026450	0.214	ANCHOR POSIT. STUD M 30, GALV.

For fixing the M30 Anchor System if the plywood formlining is not drilled through.

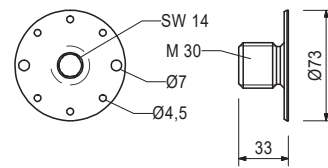

Accessory (not included)

027212	0.445	HEXAGONAL RECESS WRENCH AF14 L
710312	0.005	NAIL 3.0X80

Art no.	Weight [kg]	
029380	0.184	ANCHOR POSIT. PLATE 20, GALV.

For fixing the M30 Anchor System if the plywood formlining is drilled through.

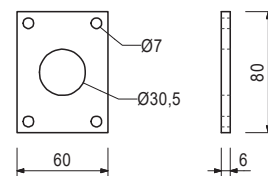

Accessory (not included)

029440	0.005	LAG SCREW 6X20 DIN 571, GALV.
--------	-------	--------------------------------------

Art no.	Weight [kg]	
057257	1.810	SCREW-ON CONE M30 /DW26

Anchor System M30.

For anchoring climbing systems.

Notes

Separate dimensioning information on request.

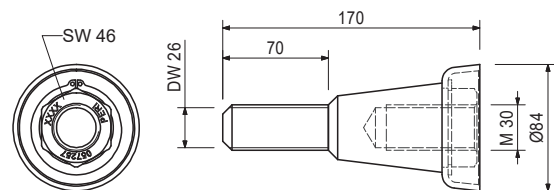
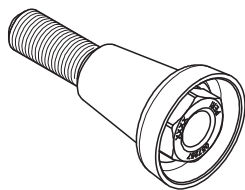

Accessory (not included)

030870	1.260	THREADED ANCHOR PLATE DW26
--------	-------	-----------------------------------

Art no.	Weight [kg]	
030860	0.792	THREADED ANCHOR PLATE DW20

For use with Tie Rod DW 20, B 20 or Screw-On Cone-2 M24/DW 20. For anchoring in concrete.

Notes

Lost anchor part.

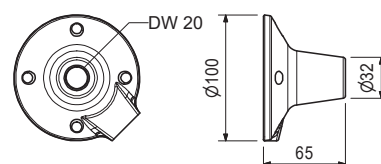
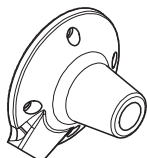

Art no.	Weight [kg]	
031220	1.050	CLIMBING CONE-2 M24/DW15

Anchor System M24. For anchoring climbing systems.

Notes

Separate design information on request.

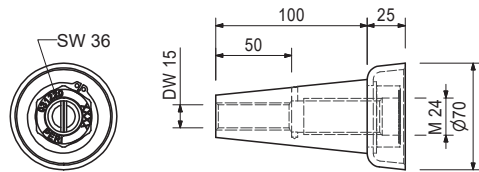
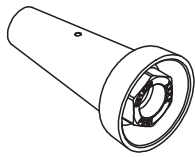

Accessory (not included)

030840	0.515	THREADED PLATE DW15
030030	1.440	TIE ROD DW15 SPEC LENGTH
030740	1.550	TIE ROD B15 SPEC LENGTH

Art no.	Weight [kg]	
030370	1.660	WINGNUT PIVOT PLATE DW15 GALV

For anchoring with Tie Rod DW 15 and B 15.
With articulated, captive nut. Maximum inclination of anchor: 8°.

Notes

Wrench size AF 27.
Permissible load 90 kN.

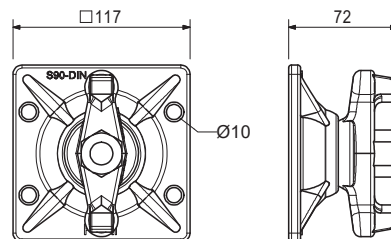
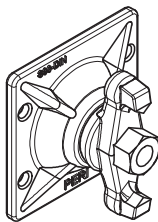

Art no.	Weight [kg]	
030700	2.560	TIE ROD DW20 SPEC LENGTH

Notes

Non-weldable! Take official Approval into consideration!
Permissible tension force 150 kN.

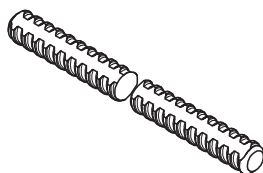

Art no.	Weight [kg]	
030030	1.440	TIE ROD DW15 SPEC LENGTH

Notes

Non-weldable! Observe the permissions! Permissible tension force 90 kN.

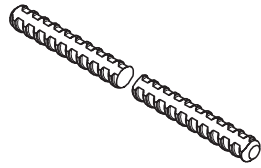

Art no.	Weight [kg]	
030870	1.260	THREADED ANCHOR PLATE DW26

For use with Tie Rod DW 26 or Screw-On Cone M36/DW 26. For anchoring in concrete.

Notes

Lost anchor part.

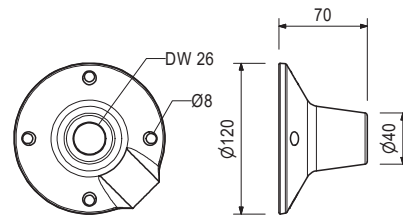
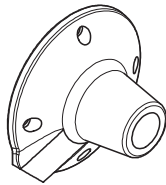

Art no.	Weight [kg]	
109503	7.380	WALL SHOE RCS

Anchor System M30. For anchoring Climbing Shoe RCS to the wall.

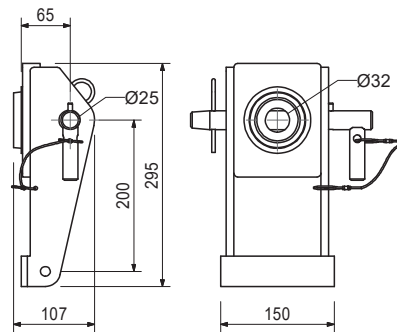
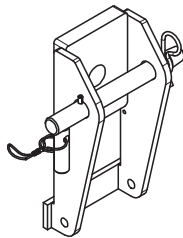

Accessory (not included)

029420	0.590	HEX BOLT ISO 4017-M30X070-8.8VZ
--------	-------	--

Consists of

- 1 pc 715585 Pin Ø 25 x 240, SKS, galv.
- 1 pc 022230 Cotter Pin 5/1, galv.

RCS-CL Lightweight Climbing Formwork



Art no.	Weight [kg]	
110667	13.700	WALL SHOE RCS, PIVOTED

Anchor System M30. For anchoring Climbing Shoe RCS to circular walls. Swivel range $\pm 15^\circ$.

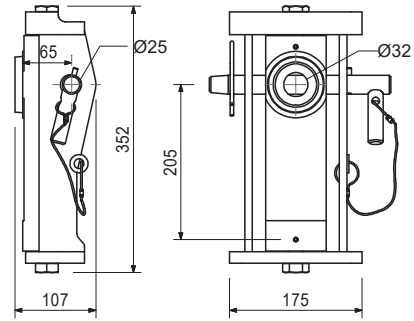
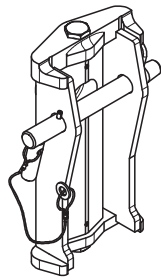

Accessory (not included)

113007	0.700	HEX BOLT ISO 4762 M30X70-8.8 GA
--------	-------	--

Consists of

- 1 pc 715585 Pin $\varnothing 25 \times 240$, SKS, galv.
- 1 pc 022230 Cotter Pin 5/1, galv.

Art no.	Weight [kg]	
110950	4.760	EXCENTRIC LEVER RCS

For dismantling Climbing Shoe RCS.

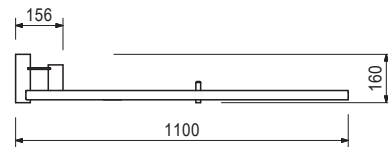
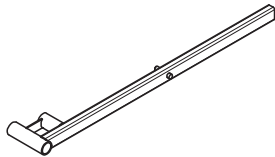

Art no.	Weight [kg]	
109765	27.000	CLIMBING DEVICE RCS 50

For crane-independent climbing of RCS Climbing Units.

Notes

- Follow Instructions for Use.
- Maximum lifting capacity 50 kN.

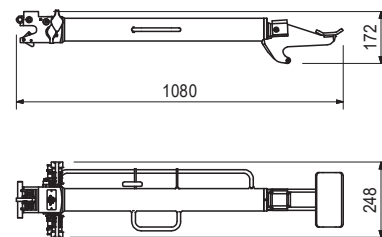
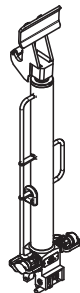

RCS-CL Lightweight Climbing Formwork

Art no.	Weight [kg]	
110069	8.500	HYDRAULIC TWIN HOSE RCS 10M

Two permanently connected hydraulic hoses for connecting hydraulic pumps with hydraulic climbing devices.

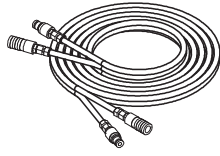

Consists of

- 2 pc 128992 Pin ISO 16028 DN10 R3/8IG
- 2 pc 128993 Sleeve ISO 16028 DN10 R3/8IG
- 4 pc 051750 Male Stud Coupler X-GE12PSR-ED

Art no.	Weight [kg]	
110070	15.300	HYDRAULIC TWIN HOSE RCS 20M

Two permanently connected hydraulic hoses for connecting hydraulic pumps with hydraulic climbing devices.

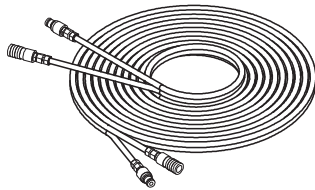

Consists of

- 2 pc 128992 Pin ISO 16028 DN10 R3/8IG
- 2 pc 128993 Sleeve ISO 16028 DN10 R3/8IG
- 4 pc 051750 Male Stud Coupler X-GE12PSR-ED

Art no.	Weight [kg]	
109766	109.000	HYDRAULIC PUMP RCS 4-FOLD

Hydraulic pump for actuating the Climbing Device RCS 50 and LPS 30.

Notes

Follow Instructions for Use.
Use only original PERI Hydraulic Oil.

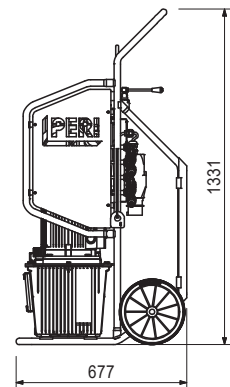
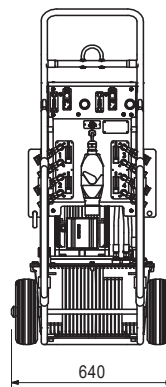
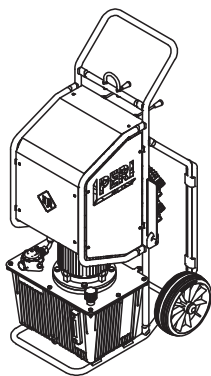

Accessory (not included)

057376	18.300	HYDR.FLUID ISO 11158 HVI46, 20L
--------	--------	--

RCS-CL Lightweight Climbing Formwork

Art no.	Weight [kg]	
110280	0.500	ADAPTER CABLE RCS

For the power supply to the Hydraulic Pump RCS.

Notes

Follow Instructions for Use!
With CEE plug connector 400 V 16 A.

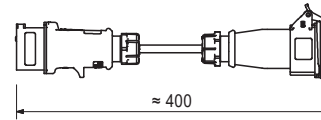
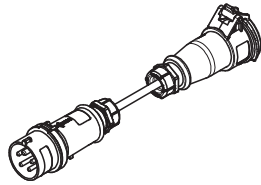

Art no.	Weight [kg]	
110279	0.291	PLUG SOCKET RCS, BLACK

For providing the power supply to the Hydraulic Pump RCS with 380 – 460 V, 50 – 60 Hz.

Notes

Follow Instructions for Use!

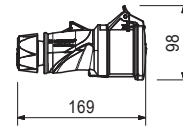

Art no.	Weight [kg]	
126431	12.300	HATCH RCS 55X60-2 FOLDABLE

Self-closing hatch for ladder access. Clear opening approx. 55 x 60 cm.
Ladder fixation with bolts or by hanging up.

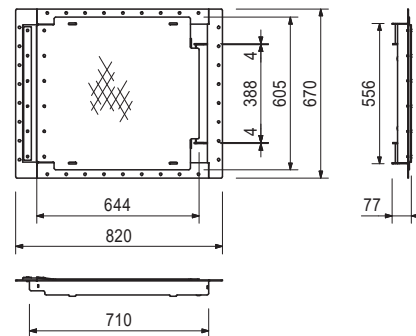
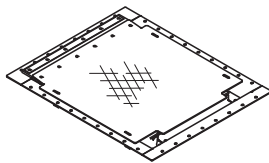

Accessory (not included)

710224	0.047	HEX BOLT ISO 4017-M12X040-8.8VZ
710381	0.017	HEX NUT ISO 7040-M12-8-GALV.

Consists of

- 1 pc 126785 Hatch Hinge RCS
- 12 pc 108647 Rivet DIN 7337- A5 x 20
- 2 pc 022230 Cotter Pin 5/1, galv.

RCS-CL Lightweight Climbing Formwork

Art no.	Weight [kg]	
051410	11.700	LADDER 180/6

For accessing PERI Formwork Systems.

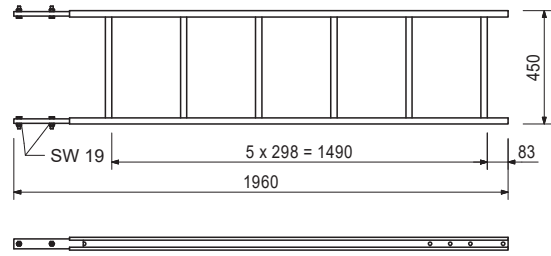
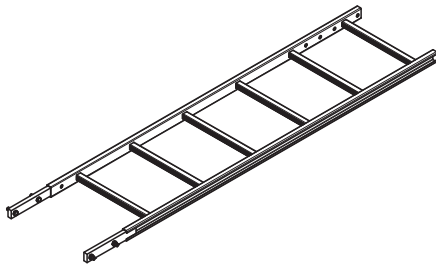

Consists of

4 pc 710224 bolt ISO 4017 M12 x 40-8.8, galv. 4 pc 710381 groove ISO 7042 M12-8, galv.

Art no.	Weight [kg]	
051420	12.800	LADDER 220/6

As access for PERI Formwork Systems.

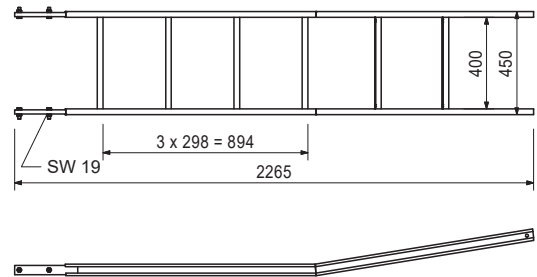
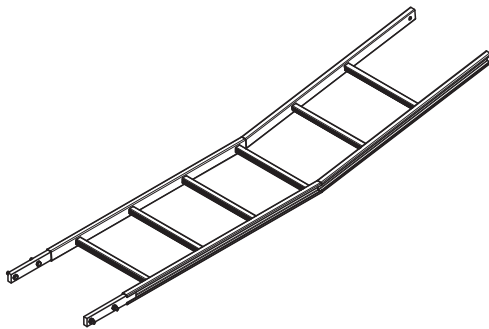

Consists of

4 pc 710224 bolt ISO 4017 M12 x 40-8.8, galv. 4 pc 710381 groove ISO 7042 M12-8, galv.

Art no.	Weight [kg]	
103724	10.400	END LADDER 180/2, CPL.

As access for PERI Formwork Systems.

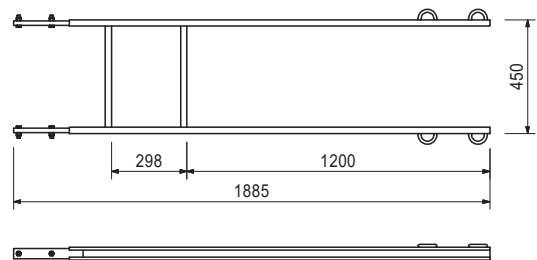
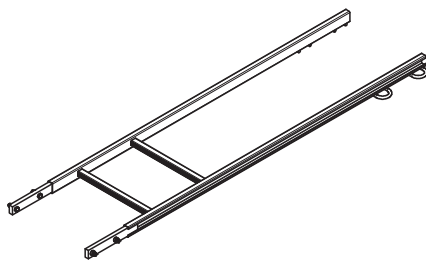

Consists of

4 pc 710224 bolt ISO 4017 M12 x 40-8.8, galv. 4 pc 710381 groove ISO 7042 M12-8, galv.

RCS-CL Lightweight Climbing Formwork

Art no.	Weight [kg]	
109105	5.070	LADDER BASE 30, GALV.

For horizontal fixing of ladders on the platform decking.

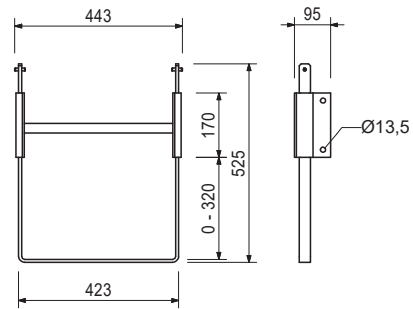
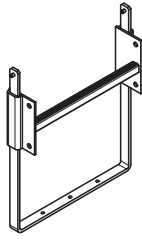

Art no.	Weight [kg]	
103718	0.684	LADDER HOOK

For adjusting the bottom ladder. Always use in pairs.

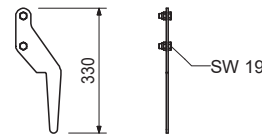

Consists of

2 pc 710266 bolt ISO 4017 M12 x 25-8.8, galv. 2 pc 710381 groove ISO 7042 M12-8, galv.

Art no.	Weight [kg]	
		Ladder cages
051450	25.200	LADDER SAFETY CAGE
104132	15.600	RAILING 75

Ladder cage for PERI ladder access.

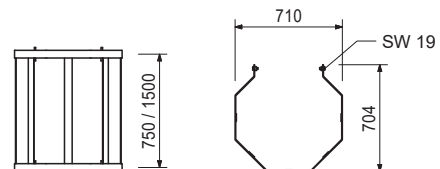
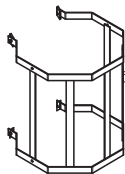

Consists of

4 pc 710266 Bolt ISO 017 M12 x 25-8.8, galv.
4 pc 701763 Clamping Plate FI 25 x 10 x 90

RCS-CL Lightweight Climbing Formwork

Art no.	Weight [kg]		L [mm]
075450	26.600	GIRDER GT 24, 450	4470

Universal formwork girder made of wood.

Notes

Approved by General Building Authorities under no.: Z-9.1-157.

For easy handling, the common lengths of the GT 24 are colour-coded.

perm. QD = 14.0 kN

perm. QZ = 13.0 kN

perm. M = 7.0 kNm

$I_y = 8,000 \text{ cm}^4$

QD = perm. shear force compression strut

QZ = perm. shear force compression force

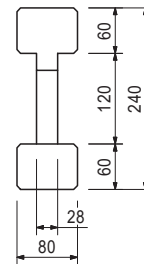
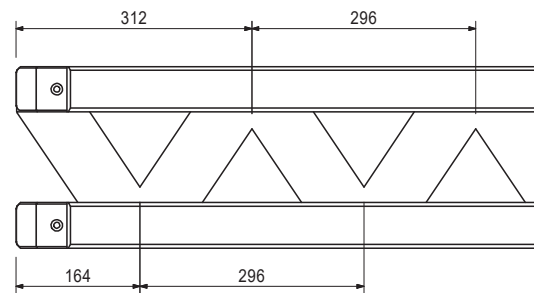
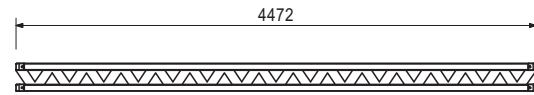
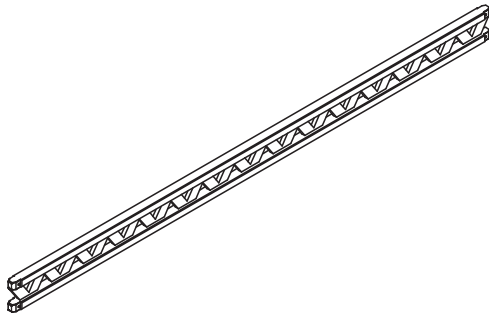

Art no.	Weight [kg]	
123478	0.255	ANGLE BRACKET 90 REINFORCED

For various timber connections.

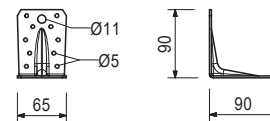

Accessory (not included)

024550	0.005	WOOD SCREW 8x20 TK-TX30 HKG
129711	0.010	WOOD SCREW 6x20 HRK-TX30 HSX

Art no.	Weight [kg]	
110289	4.260	L-ANGLE RCS 120X120X200

For fixing end handrail posts on the decking.

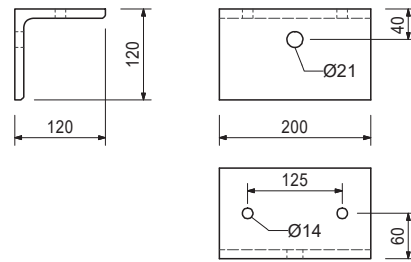
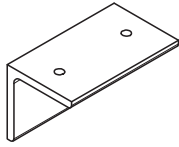

Accessory (not included)

131404	1.080	SCREW-ON COUPL.-2 HT B D48-M20
--------	-------	---------------------------------------

Art no.	Weight [kg]	
110296	0.220	CLAMP A64 DIN 3570 M12, GALV.

For assembling scaffolding tubes on Railing Posts RCS.

Notes

Wrench size AF 19.

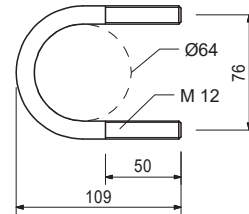
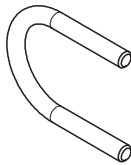

Accessory (not included)

710330	0.017	HEX NUT ISO 4032-M12-8-VZ
--------	-------	----------------------------------

Art no.	Weight [kg]	
131404	1.080	SCREW-ON COUPL.-2 HT B D48-M20

For screwing scaffolding tubes Ø 48 mm to components up to 9 mm thick.

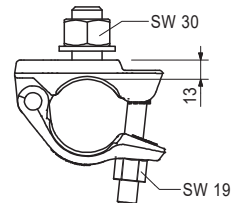
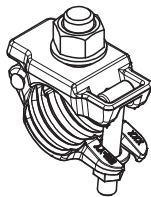

Art no.	Weight [kg]	
109720	26.600	GUARDRAIL POST U100, 225 RCS

For assembly of the guardrail on the main platform with RCS Formwork Scaffolding or on Guardrail Post Holder Multi .

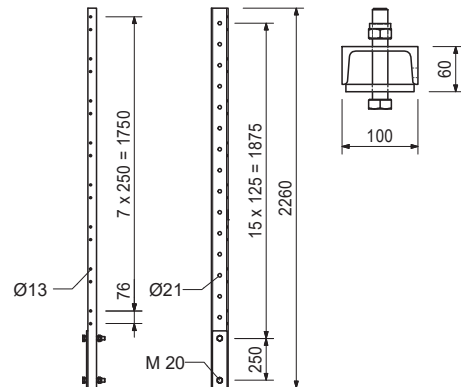

Accessory (not included)

110296	0.220	CLAMP A64 DIN 3570 M12, GALV.
710330	0.017	HEX NUT ISO 4032-M12-8-VZ
710709	0.036	F.H.BOLT M08X065MUDIN 603-4.8VZ
780354	0.002	WASHER ISO 7089-08-200HV-VZ
057345	0.010	WASHER 9MM DIN 434 GALV.

Consists of

2 pc 104477 bolt ISO 4014 M20 x 120-8.8, galv. 2 pc 781053 groove ISO 7040 M20-8, galv.

Art no.	Weight [kg]	
114328	16.600	HANDRAIL POST RCS/SRU 184

For assembly of the guardrail on the Platform Beam RCS/SRU or Guardrail Post Holder Multi.

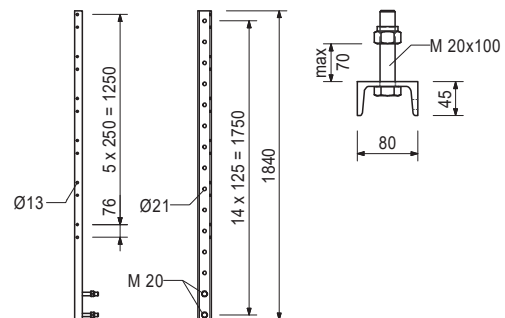

Accessory (not included)

110296	0.220	CLAMP A64 DIN 3570 M12, GALV.
710330	0.017	HEX NUT ISO 4032-M12-8-VZ
710709	0.036	F.H.BOLT M08X065MUDIN 603-4.8VZ
780354	0.002	WASHER ISO 7089-08-200HV-VZ
057345	0.010	WASHER 9MM DIN 434 GALV.

Consists of

2 pc 114727 bolt ISO 4017 M20 x 100-8.8, galv. 2 pc 781053 groove ISO 7040 M20-8, galv.

Art no.	Weight [kg]	
109721	40.700	GUARDRAIL POST U100, 384 RCS

For assembly of the guardrail on the intermediate and finishing platforms with RCS Formwork Scaffolding or as horizontal strut in the bracing.

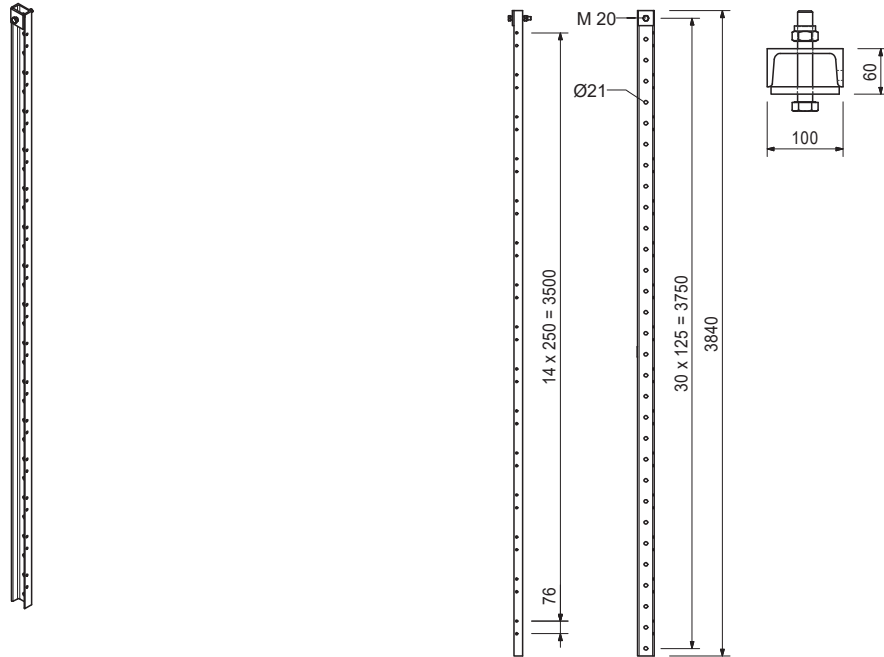

Consists of

1 pc 104477 bolt ISO 4014 M20 x 120-8.8, galv. 1 pc 781053 groove ISO 7040 M20-8, galv.

Art no.	Weight [kg]	
126088	4.390	GUARDRAIL POST HOLDER MULTI

For fixing of an end guardrail post on Girders GT 24, VT 20 or KH 80/160. Fixing of the guardrail posts by means of Hex. Bolts M20.

Notes

Suitable for
 Guardrail Post RCS 226 item no.: 109720
 Guardrail Post RCS /SRU 184 item no.: 114328
 Vertical scaffolding tubes
 Special Post QR 50 x 50

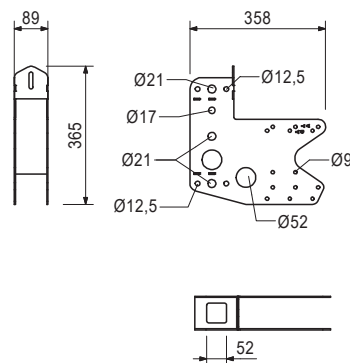
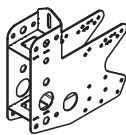

Accessory (not included)

710285	0.050	HEX BOLT ISO 4014-M08X100-8.8VZ
024090	0.005	NUT M8, GALV.
024470	0.008	TSS-TORX 6X60, GALV.

Art no.	Weight [kg]		L [mm]
		Steel scaffolding tubes Ø 48.3	
026417	0.000	Cutting costs for scaffolding tubes	1
026411	3.550	SCAFFOLDING TUBE 48.3x3.2 L=1.0M	1000
026412	7.100	SCAFFOLDING TUBE 48.3x3.2 L=2.0M	2000
026413	10.650	SCAFFOLDING TUBE 48.3x3.2 L=3.0M	3000
026414	14.200	SCAFFOLDING TUBE 48.3x3.2 L=4.0M	4000
026418	21.600	SCAFFOLDING TUBE 48.3x3.2 L=6.0M	6000
026415	3.550	SCAFFOLDING TUBE 48.3x3.2 LFM	1000
125976	8.900	SCAFFTUBE 48.3X3.2X2500, GALV	2500
114287	12.500	SCAFFTUBE 48.3X3.2X3500, GALV	3500
026419	17.750	Steel scaffolding tube Ø 48.3 x 3.2, L = 5.0 m	5000

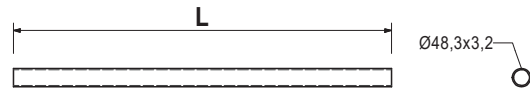
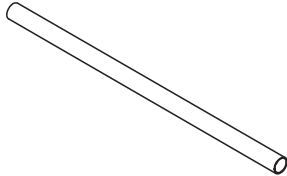

Art no.	Weight [kg]	
017020	1.120	STANDARD COUPLER RA 48/48 GALV

For scaffolding tubes Ø 48 mm.

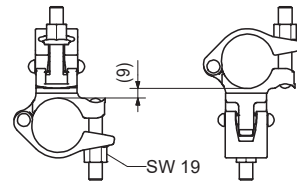
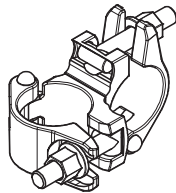

Art no.	Weight [kg]	
017010	1.400	SWIVEL COUPLER AF 48/48 GALV.

For scaffolding tubes Ø 48 mm.

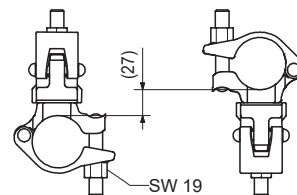
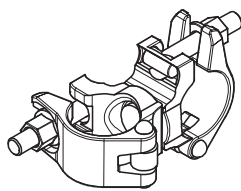

Art no.	Weight [kg]	
118579	6.280	GUARDRAIL POST SCS 150

Guardrail post to connect handrail boards and toe boards.

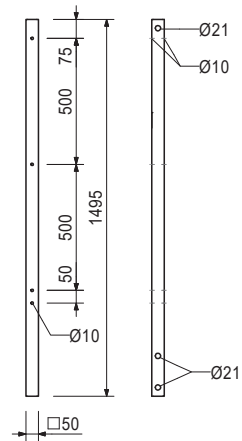

Accessory (not included)

113762	0.884	GUARDRAIL CONN. PLATE ACS/SCS
051160	1.050	HANDRAIL CONNECTOR CB

Art no.	Weight [kg]	
065033	0.010	CONES 22

Plastic. Suitable for Spacer Tube DR 22.

Notes

Delivery unit 500 pieces.

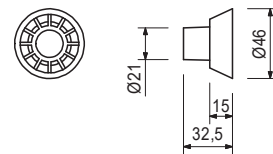

Art no.	Weight [kg]	
125856	2.580	SCAFFOLDING TUBE ADAPTER LPS/RCS

For assembling Scaffolding Tubes Ø 48 to Climbing Rail RCS.

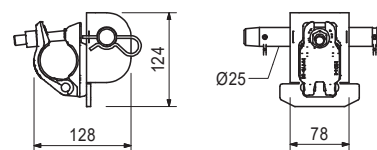
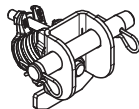

Consists of

- 1 pc 017040 Screw-On Coupler AK 48, galv.
- 1 pc 710894 Pin Ø 25 x 180, geomet.
- 2 pc 018060 Cotter Pin 4/1, galv.

RCS-CL Lightweight Climbing Formwork

Art no.	Weight [kg]	
051160	1.050	HANDRAIL CONNECTOR CB

For assembling scaffolding tubes on handrail posts.

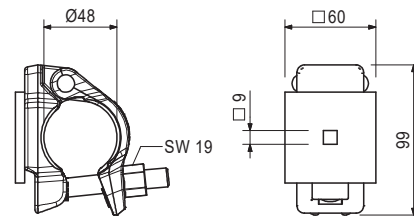
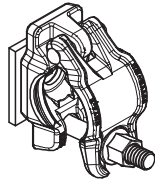

Accessory (not included)

126228	0.030	FH.BOLT M08X070-DIN 603-8.8VZ
--------	-------	--------------------------------------

Art no.	Weight [kg]		L [mm]
710224	0.047	HEX BOLT ISO 4017-M12X040-8.8VZ	40

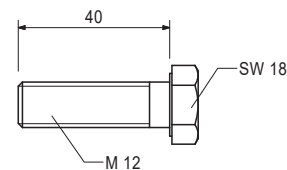
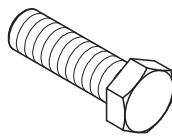

Art no.	Weight [kg]		L [mm]
110598	0.142	HEX BOLT ISO f4017-M12X140-8.8-G	140

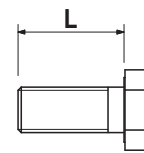
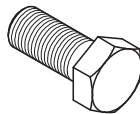

Art no.	Weight [kg]		L [mm]
104477	0.300	HEX BOLT ISO 4014 M20X120-8.8,G	120

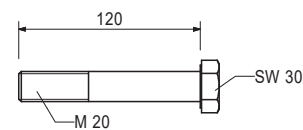
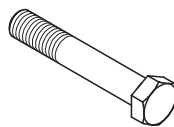

Accessory (not included)

781053	0.065	HEX NUT ISO 7040-M20-8-VZ
--------	-------	----------------------------------

Art no.	Weight [kg]		L [mm]
711084	0.420	HEX BOLT ISO 4014-M20X150-8.8VZ	150

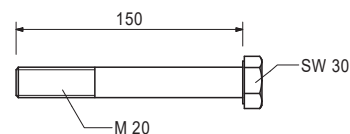
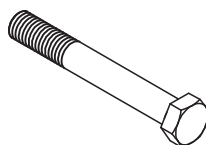

Accessory (not included)

781053	0.065	HEX NUT ISO 7040-M20-8-VZ
--------	-------	----------------------------------

RCS-CL Lightweight Climbing Formwork

Art no.	Weight [kg]		W [mm]	L [mm]
109612	0.600	HEX.BOLT ISO 4014 M24X130-8.8GV		130

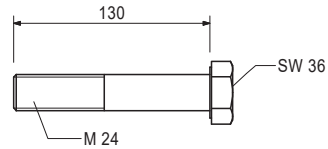
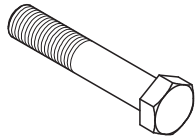

Art no.	Weight [kg]		W [mm]	L [mm]
710240	0.050	F.H BOLT M8X100 W.GROOVE	80	100

With nut.

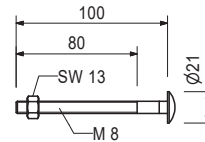
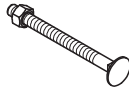

Art no.	Weight [kg]		W [mm]	L [mm]
126228	0.030	F.H.BOLT M08X070-DIN 603-8.8VZ		

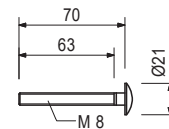

Art no.	Weight [kg]		W [mm]	L [mm]
024090	0.005	NUT M8, GALV.		

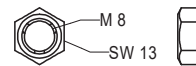

Art no.	Weight [kg]		W [mm]	L [mm]
024390	0.090	FH BOLT M 8X200 W.GROOVE	150	200

With nut.

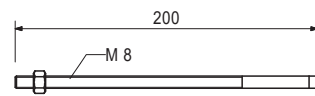
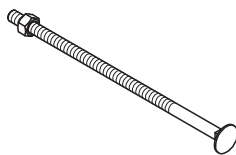

Art no.	Weight [kg]		W [mm]	L [mm]
131375	0.058	F.H BOLT M08X125-8.8-GAL W.NUT		

With nut.

Notes

Wrench size AF 13.

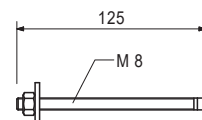
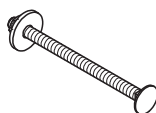

RCS-CL Lightweight Climbing Formwork

Art no.	Weight [kg]	
781053	0.065	HEX NUT ISO 7040-M20-8-VZ

Self-locking.

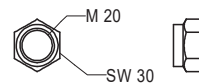

Art no.	Weight [kg]	
710381	0.017	HEX NUT ISO 7040-M12-8-GALV.

Self-locking.

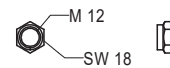

Art no.	Weight [kg]	
710342	0.007	WASHER ISO 7093-1-08-200HV-VZ

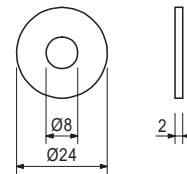

Art no.	Weight [kg]	
780354	0.002	WASHER ISO 7089-08-200HV-VZ

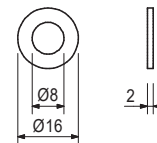

Art no.	Weight [kg]	
113348	0.043	WASHER ISO 7094-12 100HV, GALV.

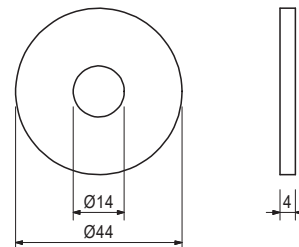
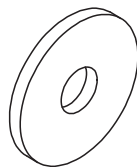

Art no.	Weight [kg]		L [mm]
024690	0.008	WOOD SCREW 6x80 SK-TX30 HPI	80

For Torx Bit Points TX 30. Self-drilling.

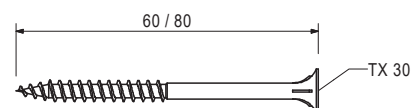
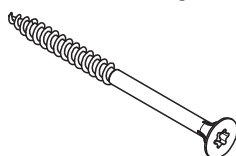

RCS-CL Lightweight Climbing Formwork

Art no.	Weight [kg]		L [mm]
024470	0.008	WOOD SCREW 6x60 SK-TX30 HPI	60

For Torx Bit Points TX 30. Self-drilling.

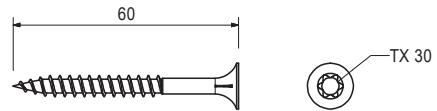
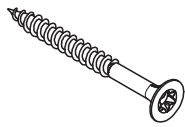

Art no.	Weight [kg]		L [mm]
024540	0.005	WOOD SCREW 6x40 SK-TX30 HPI	40

For Torx Bit Points TX 30. Self-drilling.

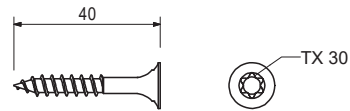
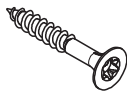

Art no.	Weight [kg]		L [mm]
111437	0.004	WOOD SCREW 5x20 SK-TX20 HSX	20

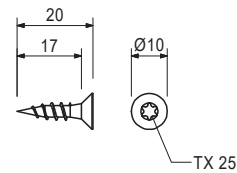
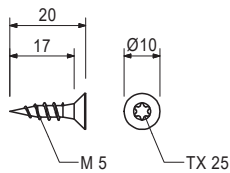

Art no.	Weight [kg]		L [mm]
024950	0.012	WOOD SCREW 6x100 SK-TX300 HSX	100

For Torx Blade TX 30. Self-drilling.

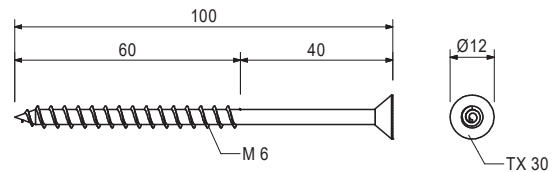
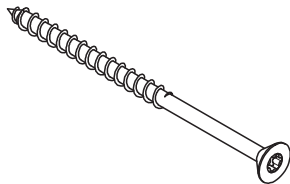

Art no.	Weight [kg]		L [mm]
029440	0.005	LAG SCREW 6X20 DIN 571, GALV.	20

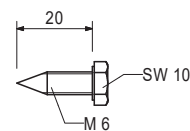

Art no.	Weight [kg]		L [mm]
024270	0.023	LAG SCREW 8X 60 DIN 571, GALV.	60

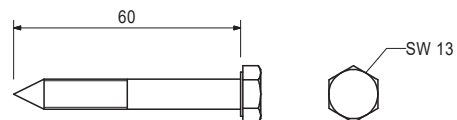
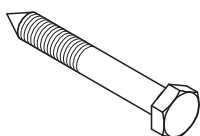

RCS-CL Lightweight Climbing Formwork

Art no.	Weight [kg]		L [mm]
024260	0.027	LAG SCREW 8X80 DIN 571, GALV.	80

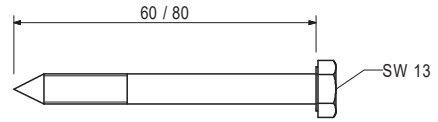
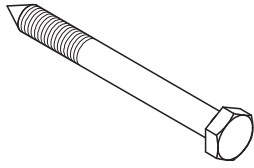

Art no.	Weight [kg]		
710312	0.005	NAIL 3.0X80	

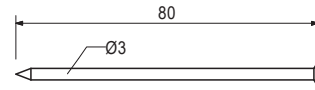
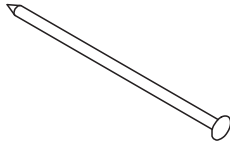

Art no.	Weight [kg]	
113745	30.200	CLIMBING RAIL EXTENS. RCS 125

For extending the Climbing Rail RCS and using the Climbing Device RCS 50 on the work platform.

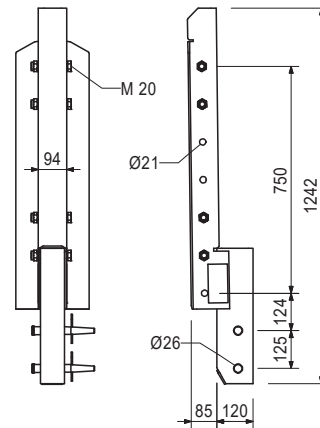

Consists of

- 4 pc 110022 Spacer M20-82
- 2 pc 111567 Fitting Pin Ø 26 x 120
- 2 pc 022230 Cotter Pin 5/1, galv.

Art no.	Weight [kg]	
110569	16.700	CLIMBING RAIL HINGE RCS

For an articulated connection of the Climbing Rails RCS and as pressure point on the RCS Climbing Brackets.

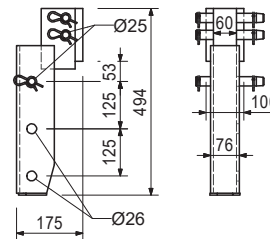
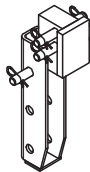

Consists of

- 3 pc 710894 Pin Ø 25 x 180, geomet.
- 4 pc 018060 Cotter Pin 4/1, galv.

Art no.	Weight [kg]	
104031	0.462	FILLER PIN D=21X120

For different connections.

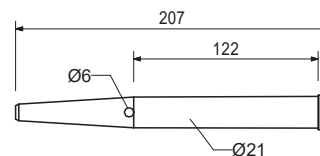
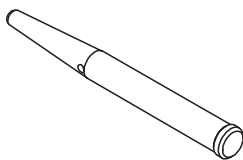

Accessory (not included)

018060	0.014	Cotter pin 4/1, galv.
--------	-------	------------------------------

Art no.	Weight [kg]	
018060	0.014	Cotter pin 4/1, galv.

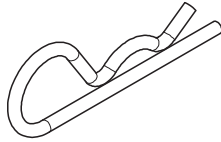

Art no.	Weight [kg]	
111567	0.729	PIN D=26X120

For different connections.

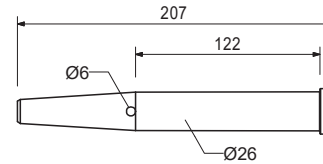
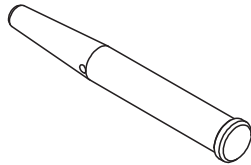

Accessory (not included)

018060	0.014	Cotter pin 4/1, galv.
--------	-------	------------------------------

Art no.	Weight [kg]	
022230	0.033	COTTER PIN 5/1, GALV.



Art no.	Weight [kg]	
127834	2.210	CRANE EYE BR-2 2.5T, galv.

As attachment point for moving climbing systems or Platform Beam BR.

Notes

Follow Instructions for Use!

Permissible load-bearing capacity 2.5 t.

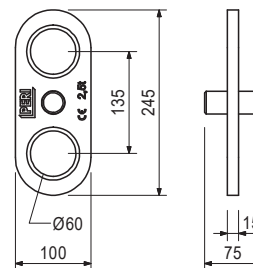

Accessory (not included)

020620	0.561	SPACER FOR PLATFORM BEAM BR
--------	-------	------------------------------------

RCS-CL Lightweight Climbing Formwork



Art no.	Weight [kg]	
109468	19.800	CLIMBING SHOE RCS

Guide and support for Climbing Rail RCS. With foldable leading runners and self-actuating bearing pawl.

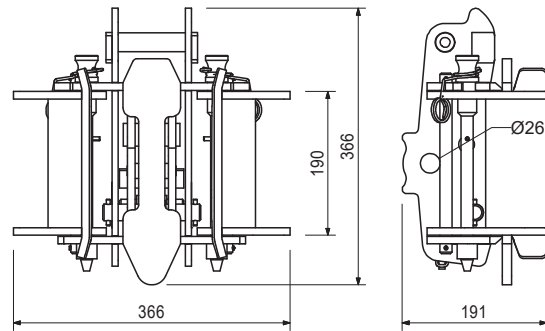
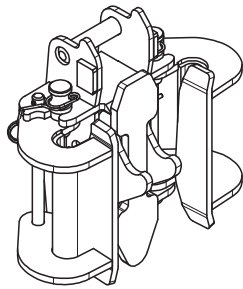

Consists of

- 2 pc 116067 Locking Device
- 2 pc 109902 Pin Ø 30 x 290, galv.
- 4 pc 711063 Dowel Pin Ø 5 x 35
- 2 pc 109508 Pin Ø 16 x 239, galv.
- 4 pc 750329 Dowel Pin Ø 5 x 20
- 1 pc 109903 Spring Lock

135962	0.379	Climbing Shoe Display RCS MAX For use as Climbing Shoe Display RCS	Complete with 1 pc. 711071 Nut ISO 7040 M8-8, galv. 1 pc. 126908 bolt ISO 4014 M8 x 45-8.8, galv.
--------	-------	--	--

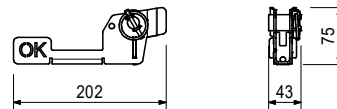
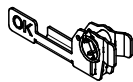

Art no.	Weight [kg]	
127320	158.000	LIFTING BEAM 9T

For moving climbing units.

Notes

Follow Instructions for Use.
Permissible load-bearing capacity 9 t.

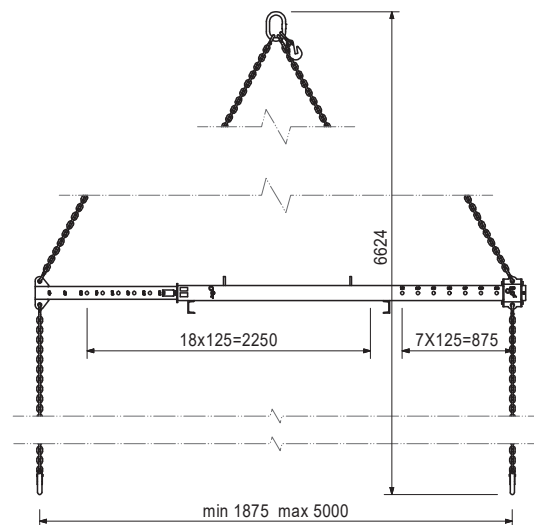
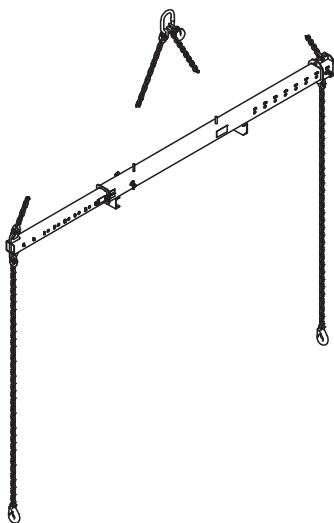

Consists of

- 1 pc 112865 Bolt 25 x 180
- 1 pc 022230 Cotter Pin 5/1, galv.
- 1 pc 107297 Bolt ISO 4014-M12 x 140-8.8, galv.
- 1 pc 010330 Nut ISO 4032 M12-8, galv.

RCS-CL Lightweight Climbing Formwork

Art no.	Weight [kg]		L [mm]	X [mm]	Y [mm]
110012	23.500	DIAGONAL STRUT L= 2121MM RCS	2217	1500	1500

For bracing RCS Framework Brackets.

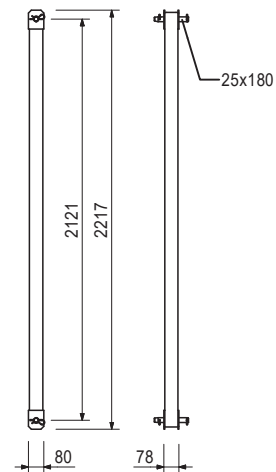
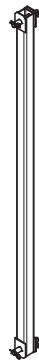

Consists of

- 1 pc 710894 Pin Ø 25 x 180, geomet.
- 1 pc 018060 Cotter Pin 4/1, galv.
- 2 pc 109612 Bolt ISO 4014 M24 x 130-8.8, galv.
- 1 pc 105032 Nut ISO 7040 M24-8, galv.

Art no.	Weight [kg]	
118094	159.000	CROSSBEAM UNIT RCS220, VARIO

Platform Beam for RCS Climbing Formwork. Assembly unit of Crossbeam RCS 220, Crossbeam Head RCS/VARIO and Carriage RCS.

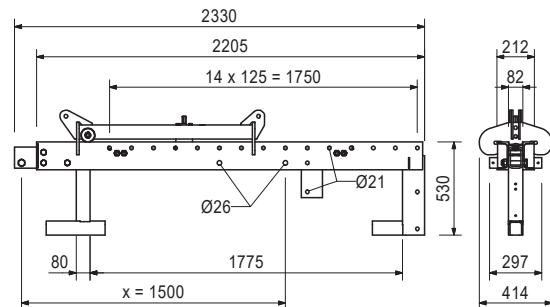
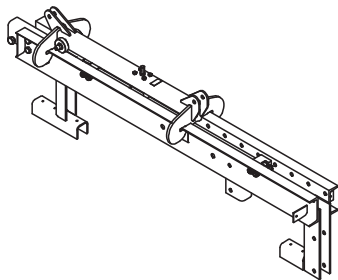

Accessory (not included)

110094	0.895	CARRIAGE CRANK LEVER AF19 RCS
710240	0.050	F.H BOLT M8X100 W.GROOVE
024390	0.090	F.H BOLT M 8X200 W.GROOVE
024470	0.008	WOOD SCREW 6x60 SK-TX30 HPI
109720	26.600	GUARDRAIL POST U100, 225 RCS
104031	0.462	FILLER PIN D=21X120
018060	0.014	COTTER PIN 4/1, GALV.

Consists of

- 1 pc 109716 Crossbeam RCS 220
- 1 pc 110015 Crossbeam Head RCS/VARIO
- 1 pc 109968 Carriage RCS
- 1 pc 109612 Bolt ISO 4014 M24 x 130-8.8, galv.
- 1 pc 105032 Nut ISO 7040 M24-8, galv.
- 1 pc 104477 Bolt ISO 4014 M20 x 120-8.8, galv.
- 1 pc 781053 Nut ISO 7040 M20-8, galv.

RCS-CL Lightweight Climbing Formwork



Art no.	Weight [kg]	
132800	10.900	CROSSBEAM HEAD RCS/VARIO

Spare part. For connecting the Crossbeam RCS 220 to the Climbing Rail RCS.

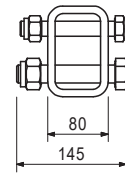
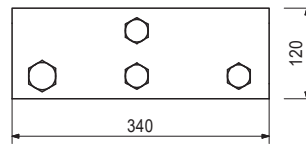
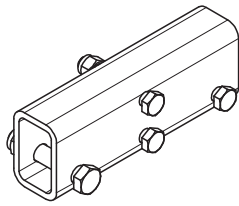

Art no.	Weight [kg]	
109968	41.500	CARRIAGE RCS

Spare part.

Self-locking carriage with roller bearings on the Crossbeam RCS 220. Formwork moveable by max. 88 cm.

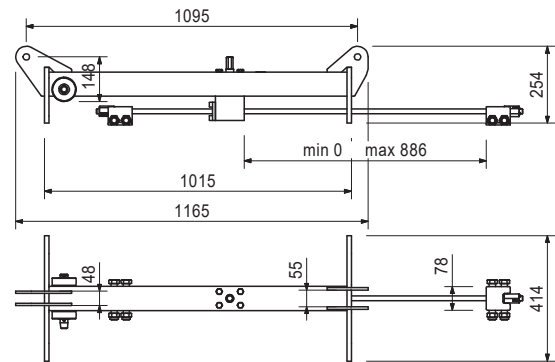
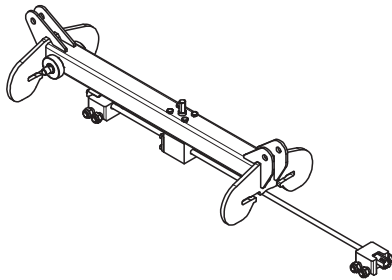

Accessory (not included)

110094	0.895	CARRIAGE CRANK LEVER AF19 RCS
--------	-------	--------------------------------------

Consists of

4 pc 104477 bolt ISO 4014 M20 x 120-8.8, galv. 4 pc 781053 groove ISO 7040 M20-8, galv.

RCS-CL Lightweight Climbing Formwork



Art no.	Weight [kg]		L [mm]
103929	72.000	STEEL WALER SRU 272 U120	2722

Universal Steel Waler Profile U120 used as waling for girder wall formwork and for various special applications. With adjustable spacers.

Notes

Permissible load: see PERI Design Tables.

SRU 120 $W_y = 121.4 \text{ cm}^3$, $I_y = 728 \text{ cm}^4$.

SRU 140 $W_y = 172.8 \text{ cm}^3$, $I_y = 1,210 \text{ cm}^4$.

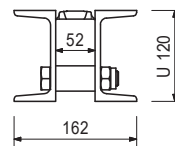
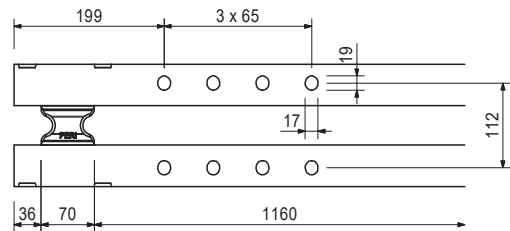
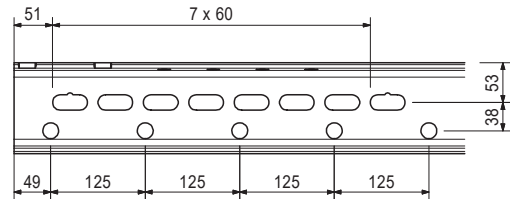
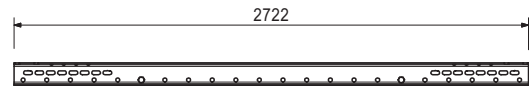
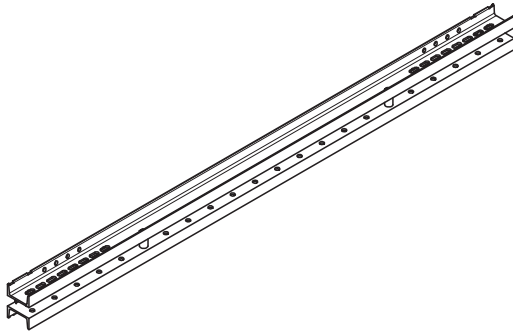

Art no.	Weight [kg]	
110059	2.840	WALER FIXATION U100-U120

For fixing VARIO GT 24 panels to Strongbacks CB, SCS and Steel Waler SRU.

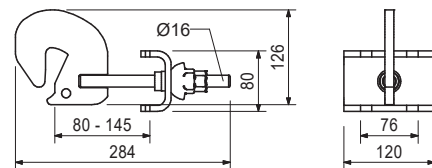
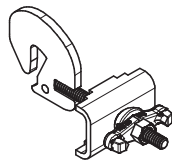

Consists of

1 pc 110055 Cross Clamp, galv.

1 pc 118260 Spherical Nut RD 16, galv.

RCS-CL Lightweight Climbing Formwork



Art no.	Weight [kg]	
110400	7.150	ADJUSTING UNIT CARRIAGE RCS

For the external height adjustment of the formwork element at the strongback (Steel Waler SRU).

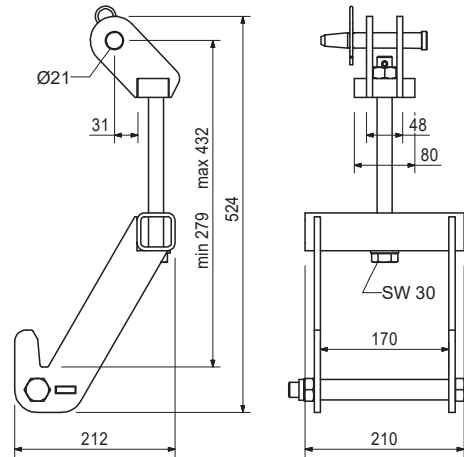
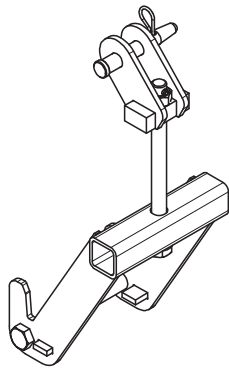

Consists of

- 1 pc 105400 Pin Ø 20 x 140, galv.
- 1 pc 018060 Cotter Pin 4/1, galv.
- 1 pc 706454 Washer ISO 7089 200 HV, A 20, galv.
- 1 pc 110637 Bolt ISO 4017-M20X260 MACH.
- 1 pc 780807 Sleeve ISO 8752-08, 0 x 028, galv.

Art no.	Weight [kg]	
127633	38.700	FORMWORK WALER 150 CB

Horizontal waler for connecting the spindle with the wall formwork.

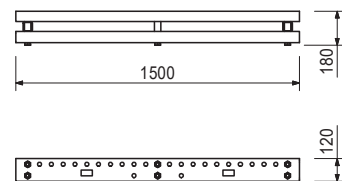
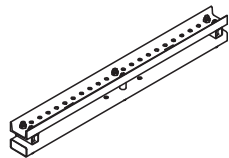

Accessory (not included)

127659	3.980	CLAMP ADAPTER MX_TR-SRU
--------	-------	--------------------------------

Art no.	Weight [kg]	
023650	0.769	TRIO HOOK TIE DW15/400, GALV.

For connecting accessories to MAXIMO and TRIO Panels. DW 15 thread.

Notes

Permissible tension force 20.0 kN.

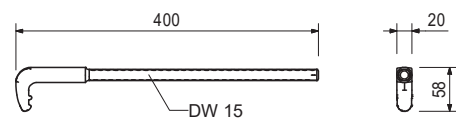
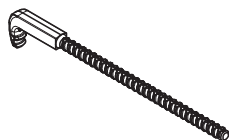

RCS-CL Lightweight Climbing Formwork

Art no.	Weight [kg]	
127659	3.980	CLAMP ADAPTER MX_TR-SRU

For the connection of Formwork Waler 150 CB to the formwork.

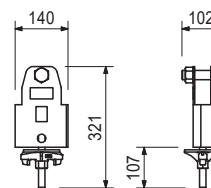

Accessory (not included)

127633	38.700	FORMWORK WALER 150 CB
--------	--------	------------------------------

Consists of

1 pc 105416 Bolt ISO 4014 M24 x 80-8.8, galv.

1 pc 022250 Nut ISO 4032 M24-8, galv.

Art no.	Weight [kg]		min. L [mm]	max. L [mm]
101778	32.300	HEAVY DUTY SPINDLE SLS 200/300	2000	3000

Used as adjustable spindle for truss beams made of Steel Walers SRU and Climbing Rails RCS.

Notes

Permissible load see PERI Design Tables.

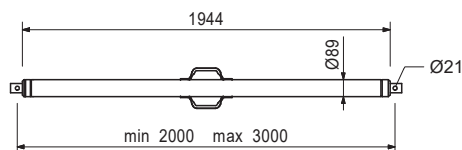
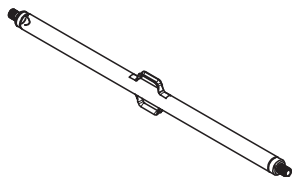

Art no.	Weight [kg]	
109722	14.200	FINISHING PLATFORM BEAM RCS

Platform beam for finishing platform.

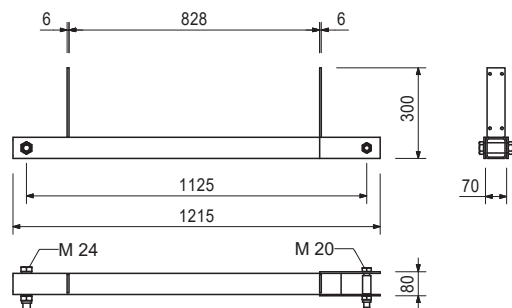
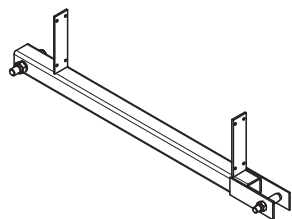

Accessory (not included)

710240	0.050	FH BOLT M8X100 W.GROOVE
024390	0.090	FH BOLT M 8X200 W.GROOVE

Consists of

1 pc 104477 Bolt ISO 4014 M20 x 120-8.8, galv.

1 pc 781053 Nut ISO 7040 M20-8, galv.

1 pc 109612 Bolt ISO 4014 M24 x 130-8.8, galv.

1 pc 105032 Nut ISO 7040 M24-8, galv.

The optimal system
for every project and
every requirement



Wall formwork



Column formwork



Slab formwork



Climbing systems

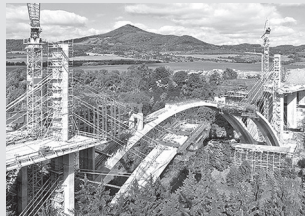

Bridge formwork



Tunnel formwork



Shoring systems



Construction scaffolds



Facade scaffolds



Industrial scaffolds



Access



Safety scaffolds



Safety systems

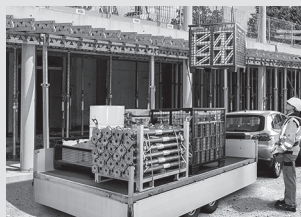

System-independent accessories



Services



PERI Ltd
Formwork Scaffolding Engineering
 Market Harborough Road
 Clifton Upon Dunsmore
 Rugby
 Warwickshire
 CV23 0AN
 +44 (0)1788 861600
 info@peri.ltd.uk
 www.peri.ltd.uk