

RCS P

Climbing Protection Panel

Instructions for Assembly and Use – standard configuration – Version 2.1

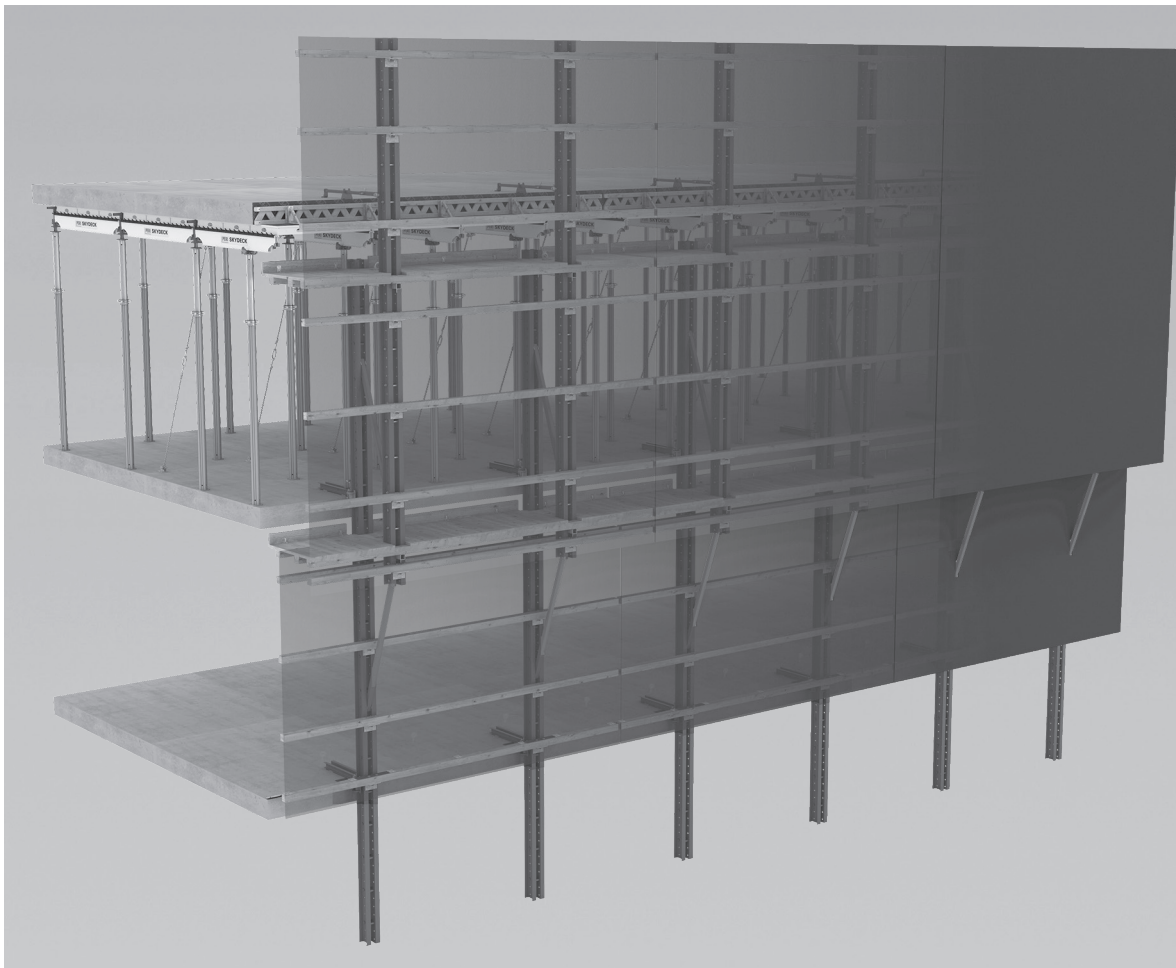

Overview

Main components	4
Key	5

Introduction

Target groups	6
Additional technical documentation	6
Product description	7
Instructions for Use	7
Cleaning and maintenance instructions	8

Safety instructions

Cross-system	9
System-specific	11
Storage and transportation	13

Component overview and tool list	14
----------------------------------	----

General

A1 System overview	16
A2 Climbing device and hydraulics	20
A3 Operating states and loads	23
A4 Work procedure	24

Process planning

B1 Planning the supporting structure	28
System dimensions	28
Framework assembly	30
Additional spacers	32
Additional finishing platforms	33
Reaction forces	35
Suspension with the slab shoe	37
Suspension with the stop end slab shoe	40
Horizontal support	41
B2 Planning the units	42
General	42
Attachment point for crane	42
Planking	44
Deck support	45
To protect workers from falling objects	46
Guardrails	48
Enclosure	50
B3 Corner platforms	52
General	52
Gap cover with cover tapes	52
Outside corners	53
Inside corners	59
Non-rectangular building corners	60
B4 Special applications	62
Units on circular structures	62
Anchoring to props or walls	63
Anchoring on the front side of the slab	64

Assembly

C1 Pre-assembly of console brackets	66
General	66
Preparing the climbing rails	66
Assembly of the attachment points	69
Assembly of Climbing Rail Connector RCS 73	71
Assembly of the bracket framework	72
Overview of the bracket framework	76

C2 Assembly of the work platforms	78
General	78
Installing the platform beams	78
Mounting the platform decking and toe boards	79
Foldable cover	80
C3 Assembly of the enclosure	84
Mounting the squared timber adapter	84
Mounting the enclosure beam	85
Mounting the Girder VT 20	86
Mounting the multi-layer plywood sheeting	87
Cover for Variant 1	88
Mounting the trapezoidal metal sheeting	89
Mounting the protection edges	90
Scaffolding tubes with nets or tarpaulins	91
C4 Attachment to the building	94
Attaching the climbing unit	94
Assembly of the climbing unit	95
Troubleshooting	100

Use

D1 Suspension and anchoring	102
Fitting the leading tie	102
Mounting the stop end slab tie	105
Fitting the suspension	106
Bracing of corner elements	110
Horizontal bracing	112
Dismantling the suspension	115
Removing the anchoring	117
D2 Operating the climbing shoe	120
Opening and closing the climbing shoe	120
Activating and deactivating the climbing pawl	122
D3 Transport by crane	124
Safety instructions	124
Preparations	125
Moving procedure	126
Troubleshooting	127
Concluding work	127
D4 Relocating with a climbing device	128
Safety instructions	128
Initial operation of the climbing hydraulics	129
Preparations	129
Hydraulic diagram	129
Remedial measures for malfunctions	129
Moving procedure	130
Self-climbing procedure	131
Concluding work	137

Dismantling

E1 Dismantling	138
Removing the climbing enclosure	138
Dismantling the climbing enclosure	140

Program overview

RCS-P Climbing Protection Panel	142
---------------------------------	-----



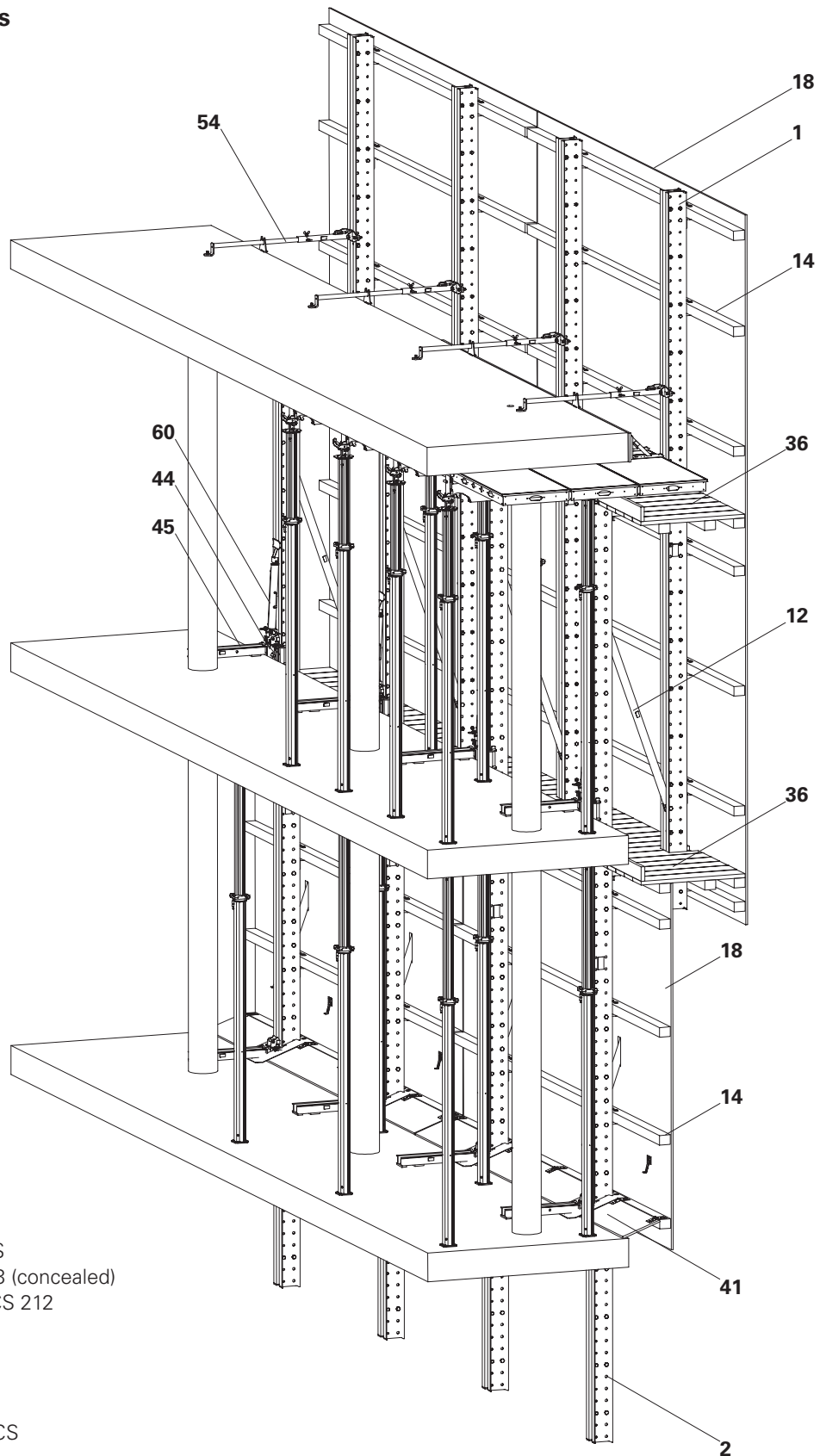









Main components





- 1 Enclosure post
- 2 Climbing Rail RCS
- 10 Crossbar RCS 103 (concealed)
- 12 Diagonal Strut RCS 212
- 14 Enclosure beam
- 18 Enclosure
- 36 Work platform
- 41 Foldable cover
- 44 Climbing Shoe RCS
- 45 Slab Shoe RCS
- 54 Slab Tie Gauge 61 RCS
- 60 Climbing Device RCS 50

Key

Pictogram | Definition

	Danger/Warning/Caution
	Note
	To be complied with
	Load-bearing point
	Visual inspection
	Tip
	Incorrect use
	Safety helmet
	Safety shoes
	Safety gloves
	Safety goggles
	Personal protective equipment to prevent falling from a height (PPE)
	Observe additional documentation

Arrows

-  Arrow representing an action
-  Arrow representing a reaction of an action*
-  Arrow representing forces

* If not identical to the action arrow.

Safety instruction categories

The safety instructions alert site personnel to the risks involved and provide information on how to avoid these risks. Safety instructions can be found at the beginning of the section or before instructions for action and are highlighted as follows:

Danger

This sign indicates an extremely hazardous situation which could result in death or serious, irreversible injury if the safety instructions are not followed.

Warning

This sign indicates a hazardous situation which could result in death or serious, irreversible injury if the safety instructions are not followed.

Caution

This sign indicates a hazardous situation which could result in minor or moderate injury if the safety instructions are not followed.

Note

This sign indicates situations in which failure to observe the information can result in material damage.

Format of the safety instructions

Signal word

Type and source of hazard!
Consequences of non-compliance.
⇒ Preventative measures.

Dimensions

Dimensions are usually given in cm. Other measurement units, e.g. m, are shown in the illustrations.

Conventions

- Instructions are numbered with: 1., 2., 3.
- The result of an instruction is shown by: →
- Position numbers are clearly provided for the individual components and are given in the drawing, e.g. **1**, in the text in brackets, for example **(1)**.
- Multiple position numbers, i.e. alternative components, are represented with a slash: e.g. **1/2**.

Notes on illustrations

The illustration on the front cover of these instructions is understood to be a system representation only. The assembly steps presented in these Instructions for Assembly and Use are shown in the form of examples with only one component size. They are valid for all component sizes contained in the standard configuration.

To facilitate understanding, detailed illustrations are sometimes incomplete. The safety equipment that might not be shown in these detailed illustrations must nevertheless be available.

Target groups

Contractor

These Instructions for Assembly and Use are designed for contractors who either

- assemble, modify and dismantle formwork systems, or
- use them, e.g. for pouring concrete, or
- allow them to be used for other operations, e.g. carpentry or electrical work.

Competent person

(Construction Site Coordinator)

The Safety and Health Protection Coordinator*

- is appointed by the client,
- must identify potential hazards during the planning phase,
- determines measures that provide protection against risks,
- creates a safety and health protection plan,
- coordinates the protective measures for the contractor and site personnel so that they do not endanger each other,
- monitors compliance with the protective measures.

Competent persons qualified to carry out inspections

Due to the specialist knowledge gained from professional training, work experience and recent professional activity, the competent person qualified to carry out inspections has a reliable understanding of safety-related issues and can carry out inspections correctly. Depending on the complexity of the inspection to be undertaken, e.g. scope of testing, type of testing or the use of certain measuring devices, a range of specialist knowledge is necessary.

Qualified personnel

Formwork systems may only be assembled, modified or dismantled by personnel who are suitably qualified to do so. Qualified personnel must have completed a course of training** in the work to be performed, covering the following points at least:

- Explanation of the plan for the assembly, modification or dismantling of the formwork in an understandable form and language.
- Description of the measures for assembling, modifying or dismantling the formwork.

- Designation of the preventive measures to be taken to avoid the risk of persons and objects falling.
- Naming of the safety precautions in the event of changing weather conditions which could adversely affect the safety of the formwork system as well as the persons concerned.
- Details regarding permissible loads.
- Description of all other risks and dangers associated with assembly, modification or dismantling operations.



- **In other countries, ensure that the relevant national guidelines and regulations in the respective current version are complied with!**
- **If no country-specific regulations are available, it is recommended to proceed according to German guidelines and regulations.**
- **A competent person must be present on site during formwork operations.**

* Valid in Germany: Regulations for Occupational Health and Safety on Construction Sites 30 (RAB 30).

** Instructions are given by the contractor themselves or a competent person selected by them.

Additional technical documentation

- Translation of Original Instructions for Use:
 - Climbing Beam RCS 9t
- Assembly instructions:
 - RCS Climbing Device and Hydraulics
 - Rail Climbing System RCS Climbing Scaffold with Carriage
- Product approvals:
 - Z-21.6-1766 PERI Screw-On Cone
 - Z-21.6-1767 PERI Climbing Cone
- Separate structural design information
- Design Tables 2015 – Formwork and Shoring

Product description

Regular assembly

These Instructions for Assembly and Use describe the standard assembly of the Rail Climbing System RCS as a climbing protection panel.

Variant 1:

Minimum width with a narrow work platform for 1 storey in advance.

Variant 2:

Several wide work platforms for 1 storey in advance.

Variant 3:

Several wide work platforms for 2 storeys in advance.

Variant 4:

Without work platforms, with straight protection screen.

Features

The RCS P Climbing Protection Panel is a standard application of the RCS Rail Climbing System.

The climbing protection panel is a bracket-type truss construction and is designed as a safety scaffold within the meaning of DIN 4420-1:2004-03. Wind load assumptions are accepted in accordance with DIN EN 1991-1-4:2010-12.

The climbing protection panel basically consists of 2 bracket structures which are connected to each other by means of work platforms and the enclosure.

Two Climbing Rails RCS connected with ledgers and struts form the bracket structure. The platforms are realised using planking and platform beams. The enclosure is attached to the climbing rails and consists of squared timbers and cladding comprising wooden multi-layer panels or trapezoidal metal sheets. Alternatively, other components can be used for the enclosure providing static proof has been obtained.

The lower Climbing Rail RCS is anchored in the floor slabs of the structure by means of climbing shoes and slab shoes. The upper climbing rail is offset and supports the enclosure projecting upwards.

Intended use

- Use in building construction projects
- To provide anti-fall protection for site personnel
- To protect workers from falling objects
- Protection against the effects of the weather

PERI products have been designed for exclusive use in the industrial and commercial sectors only by suitably trained personnel.

Instructions for Use

Use in a way not intended, deviating from the standard configuration or the intended use according to the Instructions for Assembly and Use and/or project-specific planning represents a misapplication with a potential safety risk, e.g. risk of falling.

Only PERI original components may be used. The use of other products and spare parts is not allowed.

Changes to PERI components are not permitted.

The system described in these Instructions for Assembly and Use may contain patent-protected components.

Cleaning and maintenance instructions

In order to maintain the value and operational readiness over the long term, clean the surface areas after every use.

The following instructions should help to keep cleaning and maintenance costs as low as possible.

For cleaning and maintenance of the hydraulic system, observe the Instructions for Use for the RCS Climbing Device and hydraulics.

Remove concrete residue with water immediately after concreting; this avoids any time-consuming and costly cleaning operations.

Never clean powder-coated components, e.g. elements and accessories, with a steel brush or hard metal scrapers; this ensures that the powder coating remains intact.

Mechanical components, e.g. spindles or gear mechanisms, must be cleaned of dirt or concrete residue before and after use, and then greased with a suitable lubricant.

Provide suitable support for the components during cleaning so that no unintentional change in their position is possible.

Do not clean components suspended on crane lifting gear.

Do not spray work platforms and access routes with concrete release agent — slip hazard!

Any repairs to PERI products are to be carried out by PERI qualified personnel only.

Cross-system

General

The contractor must ensure that the Instructions for Assembly and Use supplied by PERI are available at all times and understood by the site personnel.

These Instructions for Assembly and Use and project-specific planning can be used as the basis for creating the risk assessment. The risk assessment is compiled by the contractor. The Instructions for Assembly and Use are not a substitute for a risk assessment!

Observe and comply with the safety instructions and permissible loads.

For the application and inspection of PERI products, the current safety regulations and guidelines valid in the respective countries must be observed.

Materials and working areas are to be inspected on a regular basis, especially before each use and assembly, for:

- damage,
- stability and
- functional correctness.

Damaged components must be exchanged immediately on site and may no longer be used.

Safety components are to be removed only when they are no longer required.

Components provided by the contractor must comply with the characteristics stipulated in these Instructions for Assembly and Use and all applicable laws and standards. Unless otherwise indicated, the following applies in particular:

- Timber components: Strength class C24 for solid wood according to EN 338.
- Scaffolding tubes: galvanised steel tubing with minimum dimensions $\varnothing 48.3 \times 3.2$ mm according to EN 12811-1:2003 4.2.1.2.
- Scaffolding tube couplings according to EN 74.

Deviations from the standard configuration are only permitted after a further risk assessment has been carried out by the contractor.

Appropriate measures for working and operational safety, as well as stability, are defined on the basis of this risk assessment.

Corresponding proof of stability can be provided by PERI on request, if the risk assessment and resulting measures to be implemented are made available.

Before and after exceptional occurrences that may have an adverse effect on the safety of the formwork system, the contractor must immediately

- produce another risk assessment and make use of its results to take suitable steps to guarantee the stability of the formwork system,
- arrange for an extraordinary inspection to be carried out by a competent person qualified to do so. The aim of this inspection is to identify and rectify any damage in good time in order to guarantee safe use of the formwork system.

Exceptional events could be:

- accidents,
- long periods of non-use,
- natural events, e.g. heavy rainfall, icing, heavy snowfall, storms or earthquakes.

Assembly, modification and dismantling work

Assembly, modification or dismantling of climbing enclosures may only be carried out by qualified persons under the supervision of a competent person. The qualified personnel must have received appropriate training for the work to be carried out with regard to specific risks and dangers.

On the basis of the risk assessment and Instructions for Assembly and Use, the contractor must create installation instructions, in order to guarantee safe assembly, modification and dismantling of the climbing enclosure.

The contractor must ensure that the personal protective equipment required for the assembly, modification or dismantling of climbing enclosure, e.g.

- safety helmet,
- safety shoes,
- safety gloves,
- safety goggles,

is available and used as intended.

If personal protective equipment against falling from a height (PPE) is required or specified in local regulations, the contractor must determine appropriate attachment points on the basis of the risk assessment.

The PPE to be used to prevent falling is determined by the contractor.

The contractor must

- provide safe working areas for site personnel, which are to be reached through the provision of safe access ways, cordon off and clearly mark danger zones.
- guarantee stability during all stages of construction, in particular during assembly, modification and dismantling operations.
- ensure and demonstrate that all loads that occur are safely transferred.

Use

Every contractor who uses or allows the climbing enclosures to be used, is responsible for ensuring that the equipment is in good condition.

If the climbing enclosure is used successively or at the same time by several contractors, the health and safety coordinator must point out any possible mutual hazards and all work must be then coordinated.

System-specific

Assembly work

The contractor must ensure that the user has an appropriate and sufficient number of tools, lifting equipment and slings, suitable and sufficient space for assembly and storage as well as adequate crane capacity at his disposal.

Unexpected hazards can always arise when assembly work is carried out. The level of risk is to be estimated according to each individual case and, if necessary, measures are to be taken to avoid or at least to minimise the risk.

If anti-fall protection cannot be used or has to be removed due to operational reasons, safety equipment must be installed in its place in order to prevent falls from any height. If the use of fall arrest equipment is deemed to be inappropriate, personal protection equipment (PPE) can be used if suitable fixing points are available.

Use a guide rope to ensure that assembly units suspended from the crane are fully under control when being moved.

Persons are not allowed to remain under suspended loads. If work under suspended loads cannot be avoided, come up with suitable safety measures and apply them. Avoid entering the area between suspended loads and the building.

Site personnel are not permitted to loiter beneath areas where assembly work is being carried out, unless the danger zone has been provided with sufficient protection against falling, overturned, sliding or rolling objects and masses. The danger zone is to be cordoned off.

Maintenance and repairs

The system components are to be inspected before each use to ensure that they are in perfect condition and function correctly. Only materials in perfect condition are to be used.

The units are to be inspected for signs of damage at regular intervals by authorised personnel. Dirt that affects functionality is to be removed immediately. Damaged components are to be inspected, removed and replaced.

If the maximum permissible wind speed has been exceeded, temperatures are outside the scope of application or after any extraordinary event has taken place such as a fire or earthquake, the functionality and load-bearing capacity of all safety components as well as the supporting structure are to be checked.

Safety components:

- Visual inspections are to be carried out by authorised personnel at regular intervals
- Before each climbing procedure or each assembly procedure, a functionality check is carried out by qualified personnel
- If parts need to be replaced, only PERI original components may be used
- Repairs are only allowed to be carried out by PERI qualified personnel
- In the case of overloading or recurrent damage, stop work operations on and under the platforms, determine the cause and rectify.

Supporting structure:

- A visual inspection is to be carried out by authorised personnel before initial use
- Only PERI original components are to be used for repairs or replacement
- In the case of overloading or recurrent damage, stop work operations on and under the platforms, determine the cause and rectify.

Other components:

- Repairs are carried out by authorised personnel and the person authorised to give instructions is to be informed
- In the event of recurring damage, determine the cause and remedy it.

Transport routes

Safe access to all working areas must be guaranteed at all times.

Preferred options are walkways, stairs, stair towers or site lifts. Ladders are only suitable for use as access means in exceptional cases.

In the case of an emergency situation, the working areas must have escape routes in place or suitable rescue equipment available. It must also be ensured that at least 1 emergency escape route or piece of rescue equipment can still be used if the power supply fails.

The access areas on the construction site must be free of obstacles and tripping hazards and must also be slip-resistant.

Protection from falling objects

Avoid installing working areas and access points in danger zones. If this is not possible due to work procedures, suitable protection equipment must be available. This also applies to work that only takes a short period of time.

Tools and materials are to be secured to prevent them from falling to the ground. Concrete residue and other forms of dirt are to be removed at regular intervals. The platforms are to be kept clean at all times.

Operational working areas at great heights are to be secured by means of appropriate structural measures to prevent objects from falling down.

Climbing procedure

The climbing system cannot be mounted for the next concreting section until the required concrete strength has been achieved.

As a result of moving the platforms, unprotected falling edges are formed. Such affected areas are to be cordoned off and additional equipment must be in place to secure those persons working at the falling edge, e.g. personal protective equipment against falling from a height (PPE)!

Site personnel, construction materials or tools must not be transported with the crane during relocation operations. Exceptions to this can be determined through the operational working and assembly instructions on the basis of a corresponding risk analysis.

The climbing procedure must be monitored by a competent and qualified person.

During the climbing procedure, clamping and crushing hazards are brought about by moving components.

The individuals carrying out the climbing procedure must be fully informed about all possible hazards.

All persons who are not required to carry out the climbing procedure must leave the danger zones.

When climbing with the hydraulic climbing device, specifications regarding the arrangement of the hydraulic hoses must be observed. If the standard arrangement is not possible, an authorised person must determine a safe and secure alternative.

In case of a malfunction, lower the platform to the next possible position, personnel are to leave the climbing unit in a safe and secure manner and an authorised person is to be notified immediately!

Storage and transportation

Store and transport components in such a way that no unintentional change in their position is possible. Detach lifting accessories and lifting gear from the lowered components only if they are in a stable position and no unintentional change is possible.

Do not drop the components.

Use PERI lifting accessories and lifting gear and only those load-bearing points provided on the component.

During the relocation procedure

- ensure that components are picked up and set down in such a way that unintentional falling over, falling apart, sliding, falling down or rolling is avoided.
- no one is allowed to remain under the suspended load.

The access areas on the construction site must be free of obstacles and tripping hazards and must also be slip-resistant.

For transportation, the substrate must have sufficient load-bearing capacity.

Use original PERI storage and transport systems, e.g. crate pallets, pallets or stacking devices.

Component overview and tool list

Pos. no.	Component name	Article no.
1	Enclosure post	–
1.1	Climbing Rail RCS 498	109471
1.2	Climbing Rail RCS 748	109472
1.3	Climbing Rail RCS 248	109469
1.4	Climbing Rail RCS 148	114166
1.5	Climbing Rail RCS 298	112102
2	Climbing Rail RCS	–
2.1	Climbing Rail RCS 748	109472
2.2	Climbing Rail RCS 998	109610
2.3	Climbing Rail RCS 248	109469
2.4	Climbing Rail RCS 348	109470
2.5	Climbing Rail RCS 398	112141
3	Spacer M20-82	110022
4	Spacer M24-82	110023
7	Girder VT 20	–
8	Lifting Eye BR-2 2.5 t	127834
9	Compression brace (squared timber)	–
10	Crossbar RCS 103	110234
11	Crossbar RCS 69	111631
12	Diagonal Strut RCS 212	110012
13	Squared Timber Adapter RCS 12/20	110290
14	Enclosure beam (squared timber)	–
15	Adapter VT20/RCS-P	126430
17	Climbing Rail Connector RCS 73	128671
18	Enclosure (multi-layer plywood sheeting)	–
19	Enclosure (trapezoidal metal sheeting)	–
20	Protection edge	–
21	Climbing Rail Extension RCS 100	109791
22	Climbing Rail Connector RCS 33	109743
23	Plate connector Ø 48/12 mm	070030
24	Fitting pin Ø 21 x 120	104031
25	Fitting pin Ø 26 x 120	111567
26	Cotter pin 4/1	018060
27	Cotter pin 5/1	022230
31	Climbing Rail Connector RCS 73	113744
36	Work platform decking	–
37	Work platform decking (planks)	–
39	Toe board	–
39.1	Angle Connector 90° reinforced	123478
40	Platform beam (squared timber)	–
41	Foldable cover	–
42	Hinge DIN 7957-200-ST	111436
43	Cover Mat RCS 70 x 70	114113
44	Climbing Shoe RCS	109468
45	Slab Shoe RCS	109567

Pos. no.	Component name	Article no.
45.2	Bolt ISO 4014 M24 x 70-10.9	026430
46	Slab Shoe RCS Corner	110375
47	Anchoring	–
47.1	Screw-On Cone-2 M24/DW 20	114158
47.2	Threaded Anchor Plate DW 20	030860
47.3	Anchor Sleeve M24	026230
47.4	Cone for anchor sleeve	–
47.5	Climbing Cone-2 M24/DW 15	031220
47.6	Tie Rod DW 15, special length	030030
47.7	Threaded Anchor Plate DW 15	030840
47.8	Spacer tube Ø 22	–
47.9	Cone DR 22	065033
47.10	Plug PP Ø 26 mm	026250
48	Stop End Slab Shoe RCS	113232
49	Bolt ISO 4017 M30 x 70-8.8	029420
50	Reducing bushing Ø 30 - 25	113822
51	Stop End Slab Tie M30/25-160	113821
52	Stop End Slab Tie M24/20-128	113820
53	Bolt ISO 4014 M24 x 70-10.9	026430
54	Slab Tie Gauge 61 RCS	114947
59	Wall Shoe RCS	109503
60	Climbing Device RCS 50	109765
61	Hydraulic twin hoses RCS 10 m	110069
62	Hydraulic twin hoses RCS 20 m	110070
63	Hydraulic Unit RCS 4 x 190 bar	109766
64	Adapter Cable RCS	110280
65	Coupling Socket RCS, black	110279
78	Fitting pin Ø 21 x 120	104031
79	Fitting pin Ø 26 x 120	111567
80	Steel scaffolding tube Ø 48.3 x 3.2	–
81	Clamp A64 DIN 3570	110296
82	Hex. Nut ISO 4032 M12-8	710330
84	Standard Coupler NK 48/48	017020
85	Guardrail	–
86	L-bracket RCS	110289
87	Squared timber 50 x 50	–
88	Safety net	–
89	Slab prop	–
90	Bolt ISO 4017 M12 x 140-8.8	110598
91	Bolt ISO 4017 M12 x 240-8.8	110599
92	Bolt ISO 4014-M20 x 120-8.8	104477
93	Hex. Nut ISO 7042-M20-8	781053
94	Bolt ISO 4014-M24 x 130-8.8	109612
95	Hex. Nut ISO 7042-M24-8	105032
96	Nut ISO 4032 M12-8	710330

Pos. no.	Component name	Article no.
97	Washer ISO 7093 200HV, A12	750350
98	TSS-Torx 6 x 80	024690
99	TSS-Torx 6 x 60	024470
109	Spax Screw TX25, 5 x 20	111437
110	Spax Screw TX30, 6 x 20	129711
111	Spax Screw TX30, 6 x 120	024960
117	Heavy-duty dowel Ø22	–
118	Heavy-duty dowel Ø30	–
119	Hex Nut DW 15 AF 30/50	030070
120	Heavy-Duty Spindle SLS 100/180	101774
121	Spindle Shoe SLS/RCS M24	115298
122	Bracing Shoe RCS DW 15	114997
123	Eye Nut RCS DW 15	115378
124	Forkhead Adapter RCS/SLS	115388
125	Articulated Spanner RCS DW 15	115375
126	Guide-in Tool RCS	114317
136	Fixation Bar RCS	114937
137	Scaffold Tube Holder LPS/RCS Ø48	125856
138	Flap Hinge LPS D48/M10	125461
139	Flap Safety Plate LPS D=48	125458
150	Reinforcing bar	–
151	PERI Tie Bolt 14/20x130	124777

Abbreviations used in these Instructions for Assembly and Use:

a_D	Tie spacing to slab edge
b_n	Width of n-th designated section
c	Climbing rail spacing
d_n	Thickness of n-th designated section
d_x	Distance to the slab edge
F	Fibre detection
G	Weight force
V	Vertical force
V_{AY}	Tie shear force
N_A	Tie tensile force
P_c	Support force of the slab
H	Height
h_n	Height of n-th designated section
h_B	Storey height
h_P	Projecting height of the protection panel
h_{nom}	Installation depth of anchoring
H_x	Horizontal force
L	Length
L_n	Length of n-th designated section
L_S	Length of tie rod
L_T	Length of the spacer tube
$L_{1,2}$	Length of the climbing rail
q	Wind load
v	Speed

Tool name
Ratchet wrench
Extension for the ratchet wrench
Spirit level
Cordless screwdriver
TORX 25 / 30 / 35 screw bits
Ring wrench, open-end wrench, socket wrench AF 16 / 18 / 21 / 30 / 36 / 46
Forstner drill Ø 45
Wood drill Ø 7 / 11 / 12 / 14
Circular saw
Torque wrench
Hammer
Round slings
4-sling lifting gear

Tightening torques

Unless otherwise indicated, PERI recommends the following guide values for screw connections as “hand-tightened” tightening torques $M_{A,hand-tightened}$. These guide values are based on EN 15048 with minimum Safety Factor 3 against breakage.

Quality class	Quality 4.6		Quality 8.8 and 10.9
	Lightly oiled	MoS2	undefined
Screw M8	8 Nm	6.6 Nm	8 Nm
Screw M10	16 Nm	13.0 Nm	16 Nm
Screw M12	30 Nm	23.0 Nm	30 Nm
Screw M16	65 Nm	54.0 Nm	65 Nm
Screw M20	100 Nm		100 Nm
Screw M24	150 Nm		150 Nm
Screw M30	260 Nm		260 Nm
Screw M36	350 Nm		350 Nm

Tightening torques have been determined for the following components:

Bolt of spacer M20	100 Nm
Bolt of spacer M24	150 Nm
Slab Shoe RCS M24	60 Nm
Stop End Slab Shoe RCS M24	100 Nm
Stop End Slab Shoe RCS M30	100 Nm
Slab Shoe RCS Corner M24	60 Nm
Clamping plate for the slab tie gauge	120 Nm
Scaffolding tube coupling	50 Nm

Climbing enclosure

The climbing enclosure can be assembled in 4 basic variants.

Variant 1:

Minimum width with a narrow work platform for one storey in advance, Storey height (h_B) = 2.80 – 4.50 m.

Variant 2:

Several wide work platforms for one storey in advance. h_B = 2.80 – 4.50 m.

Variant 3:

Several wide work platforms for two storeys in advance. h_B = 2.80 – 4.00 m.

Variant 4:

Without work platforms, with straight protection screen. h_B = 2.80 – 4.50 m.

In all variants, the climbing rails (2) are supported by slab shoes (45) which are mounted on pre-completed floor slabs.

The enclosures, e.g. multi-layer plywood sheets (18) or trapezoidal metal sheeting (19) are mounted on the climbing rails (2) using squared timbers (14) and squared timber adapters (13).

Spacings between floor slabs and the climbing enclosure are closed with foldable covers (41). During the climbing procedure, these are folded up and secured in position.

Assembly of the climbing enclosure varies depending on the storey height, projection of the slab formwork and type of lateral protection used.

Variant 1

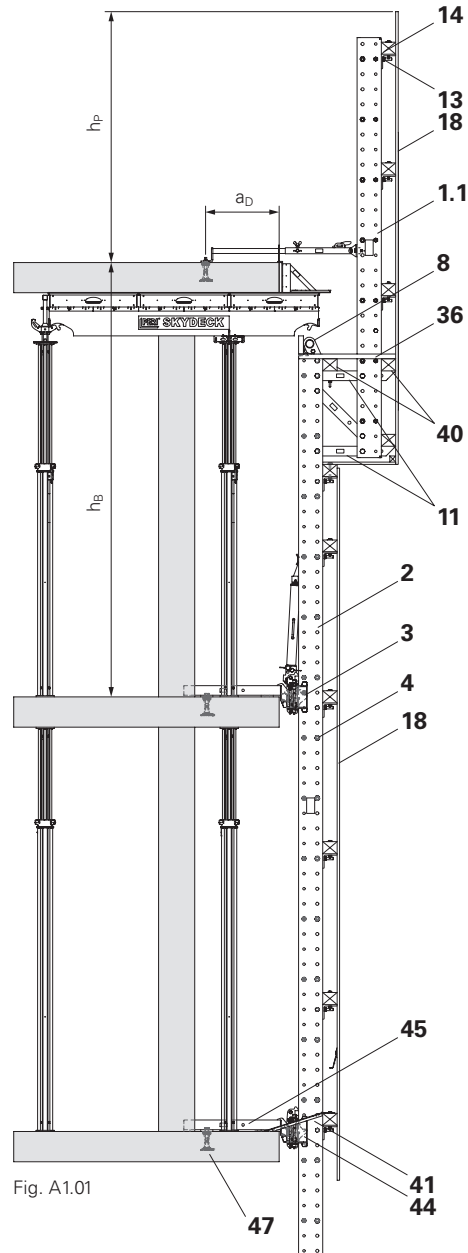

Components

- 1.1 Climbing Rail RCS 498
- 1.2 Climbing Rail RCS 748
- 2 Climbing rail
- 2.2 Climbing Rail RCS 998
- 3 Spacer M20-82
- 4 Spacer M24-82
- 8 Lifting Eye BR-2 2.5 t
- 10 Crossbar RCS 103
- 11 Crossbar RCS 69
- 12 Diagonal Strut RCS 212
- 13 Squared Timber Adapter RCS 12/20
- 14 Enclosure beam (squared timber)
- 18 Enclosure (multi-layer plywood sheeting)
- 36 Work platform decking
- 40 Platform beam (squared timber)
- 41 Foldable cover
- 44 Climbing Shoe RCS
- 45 Slab Shoe RCS
- 47 Anchoring

Variant 2

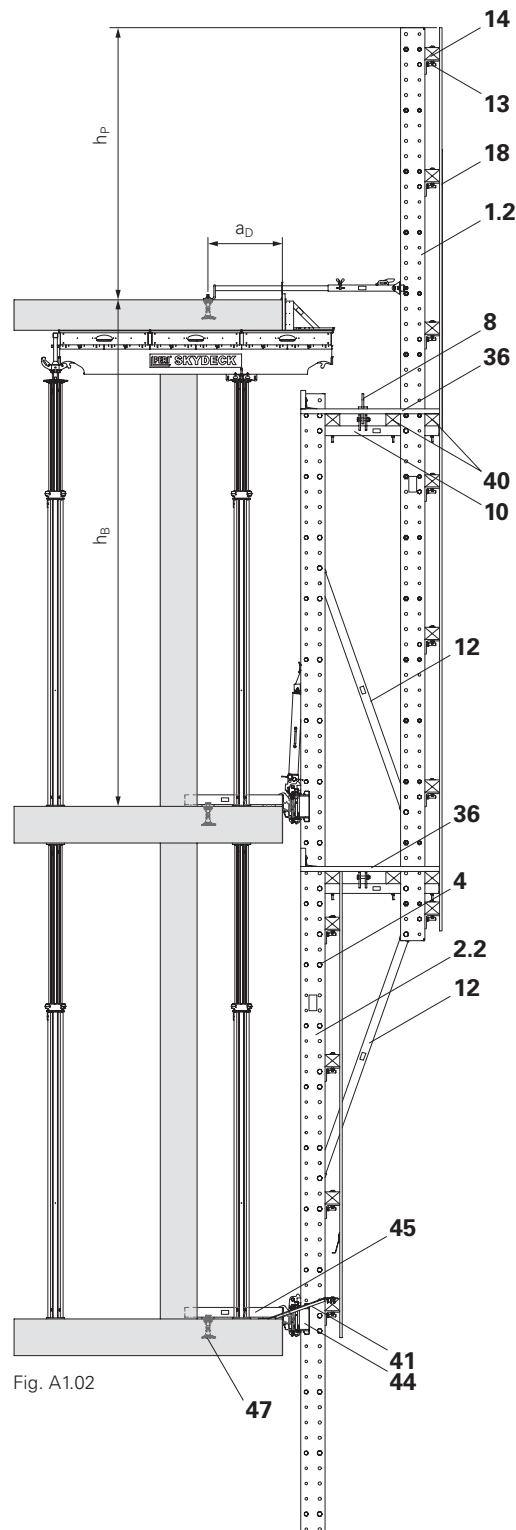

Fig. A1.02

47

Components

- 1.2 Climbing Rail RCS 748
- 1.4 Climbing Rail RCS 148
- 1.5 Climbing Rail RCS 298
- 2 Climbing rail
- 8 Lifting Eye BR-2 2.5 t
- 10 Crossbar RCS 103
- 12 Diagonal Strut RCS 212
- 13 Squared Timber Adapter RCS 12/20
- 13.1 Eyebolt M20
- 14 Enclosure beam (squared timber)
- 17 Climbing Rail Connector RCS/LPS 73
- 18 Enclosure (multi-layer plywood sheeting)
- 31 Climbing Shoe Connector RCS 73
- 36 Work platform decking
- 39 Toe board
- 40 Platform beam (squared timber)
- 41 Foldable cover (multi-layer plywood sheeting)
- 42 Hinge DIN 7957-200-ST
- 44 Climbing Shoe RCS
- 45 Slab Shoe RCS
- 47 Anchoring
- 60 Climbing Device RCS 50
- 90 Bolt ISO 4017 M12 x 140-8.8
- 91 Bolt ISO 4017 M12 x 240-8.8
- 92 Bolt ISO 4014-M20 x 120-8.8
- 94 Bolt ISO 4014-M24 x 130-8.8
- 96 Nut ISO 4032 M12-8
- 120 Heavy-Duty Spindle SLS 100/180

(Fig. A1.03 – A1.06)

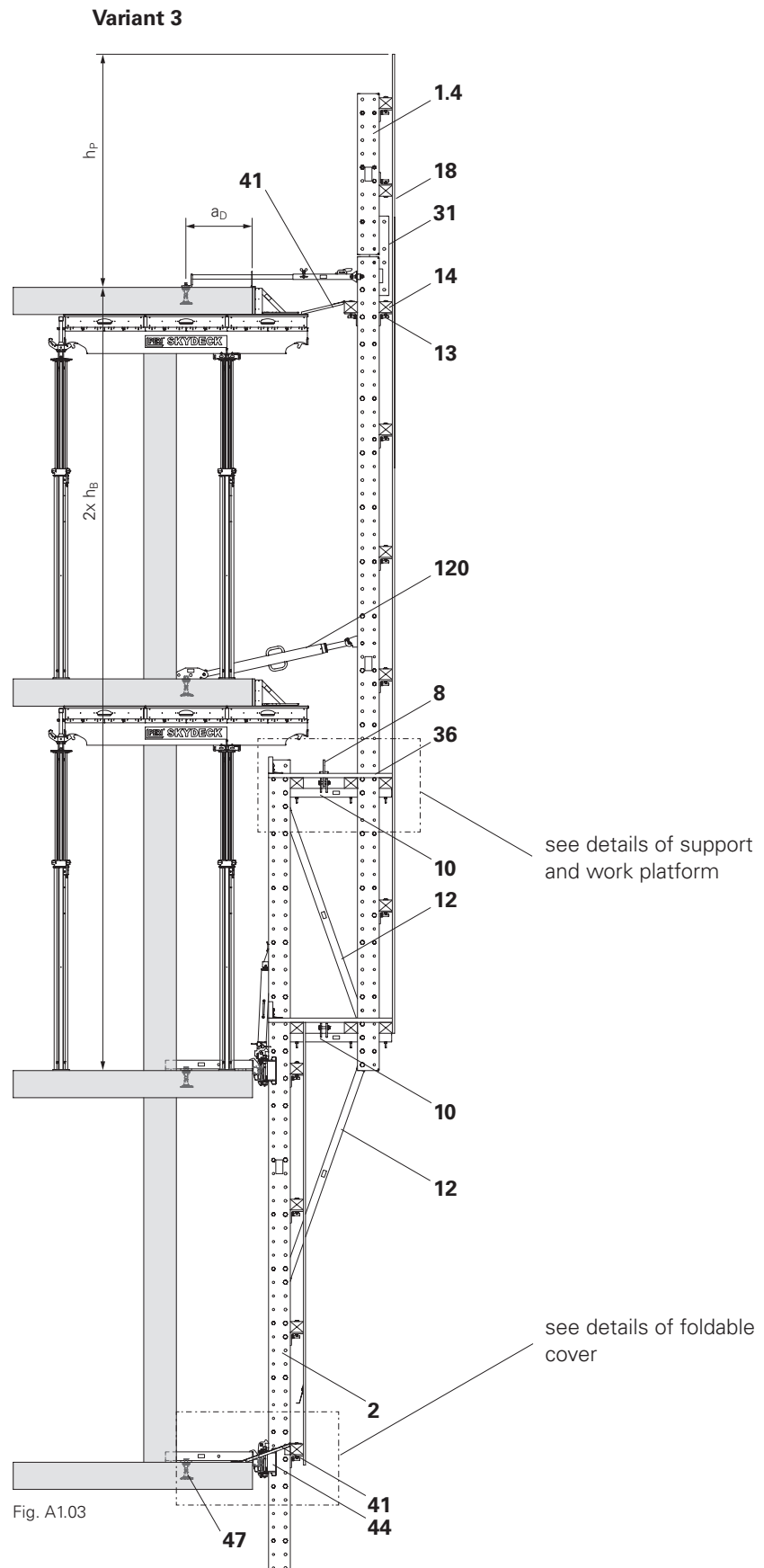

Variant 4

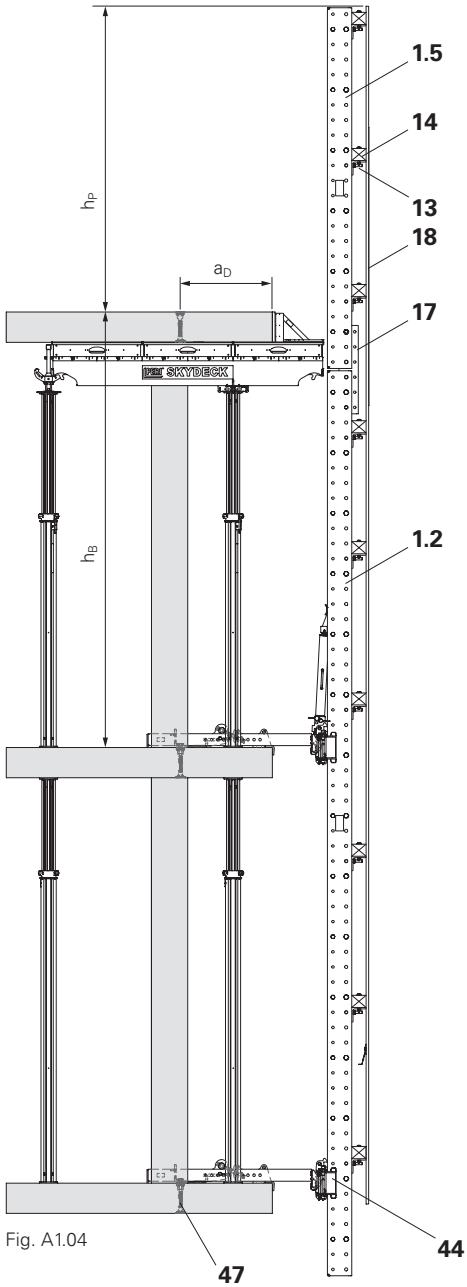

Fig. A1.04

Details of support and work platform

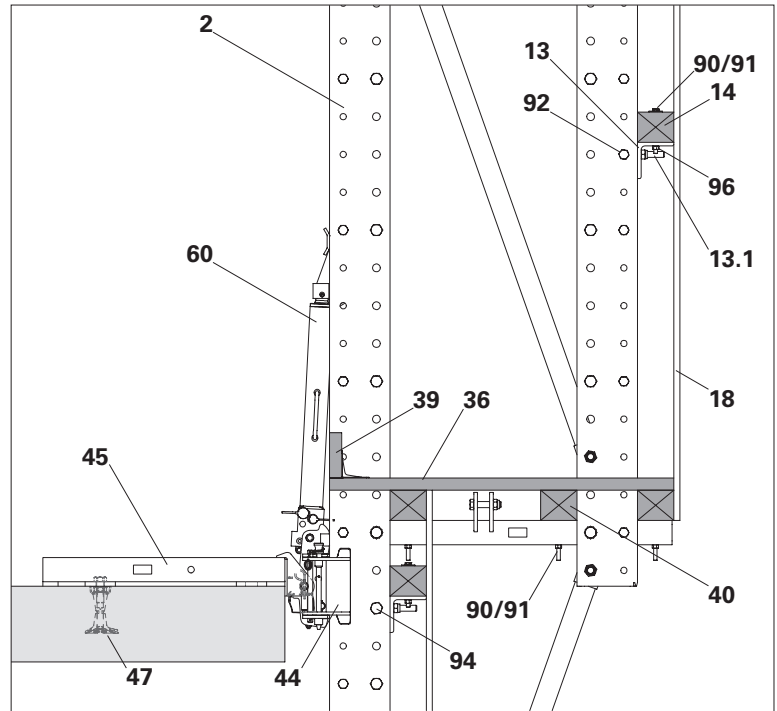

Fig. A1.05

Details of foldable cover

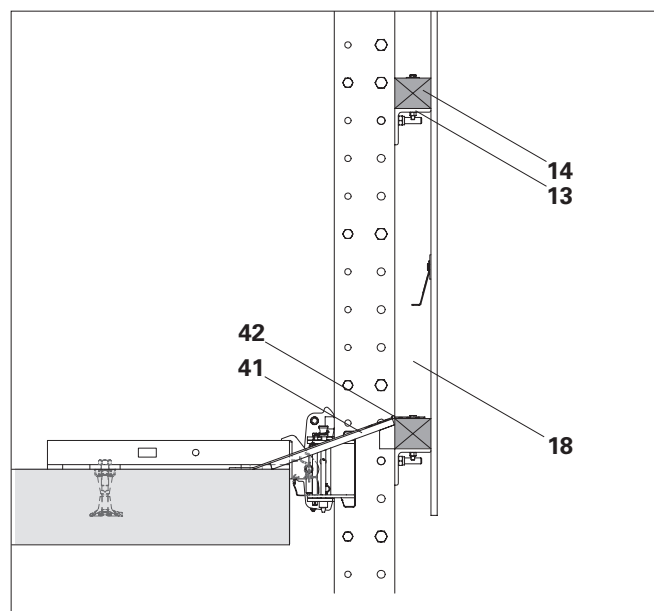

Fig. A1.06

Climbing device and hydraulics

This section provides basic information about the climbing device and hydraulic unit. Further information is provided in the following sections, as well as in the separate Instructions for Use for the RCS Climbing Device and hydraulics.

Climbing Device RCS 50

The Climbing Device RCS 50 is used to gradually climb the climbing enclosure. After the climbing procedure is completed, the climbing enclosure must be placed on the climbing pawls of the climbing shoes ensuring that the load is fully supported. The climbing device must be free of load.

(Fig. A2.01 + A2.02)

Main components

- 60** Climbing Device RCS 50 (1*)
- 60.1** Piston with claw and roller
- 60.2** Cylinder base
- 60.3** Return from rod side with hydraulic quick coupler (nipple) left and right with protective cap
- 60.4** Inflow to the piston base with the hydraulic quick coupler (bushing) left + right with protective cap
- 60.5** Cylinder repositioning (spring-loaded)
- 60.6** Locking lever (spring-loaded)

The quick couplers on the climbing device and hydraulic unit are interchangeable. Feed line and return line cannot be mixed up.

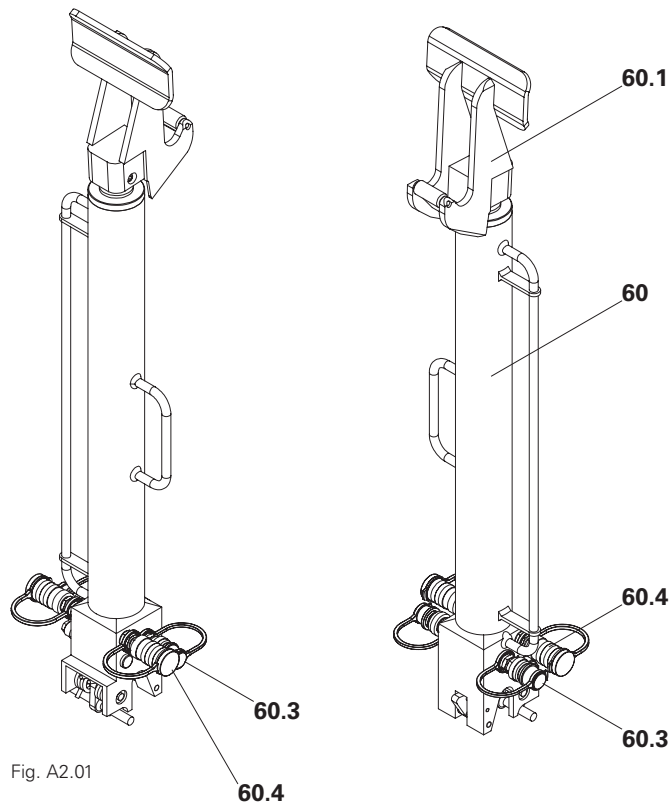

Fig. A2.01

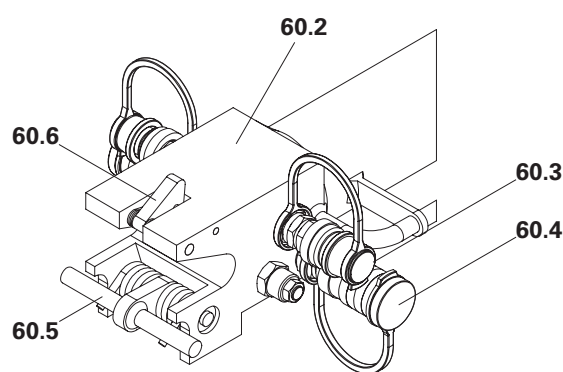

Fig. A2.02



To avoid collisions of the quick couplers with platforms or other parts of the climbing protection panel during climbing, it is possible to arrange the couplers vertically with angle pieces.
→ Contact PERI

1* safety components.

Hydraulic unit

Hydraulic Unit RCS 4 x 190 bar,
380 – 460 V (63) for 4 climbing
devices 1*
(Fig. A2.03)

Main components

- 63** Hydraulic Unit RCS
4 x 190 bar, 380 - 460 V
- 63.1** Control lever
- 63.2** Switch unit
- 63.3** Power socket with phase inverter
- 63.4** Hydraulic oil tank
- 63.5** Filler tube
- 63.6** Oil level indicator; thermometer
- 63.7** Oil filter
- 63.8** Return from the piston-rod side of
the cylinder with the hydraulic
quick coupler (bushing)
- 63.9** Inflow to the piston head side of
the cylinder with hydraulic quick
coupler (nipple)
- 63.10** Rotary field control lamp

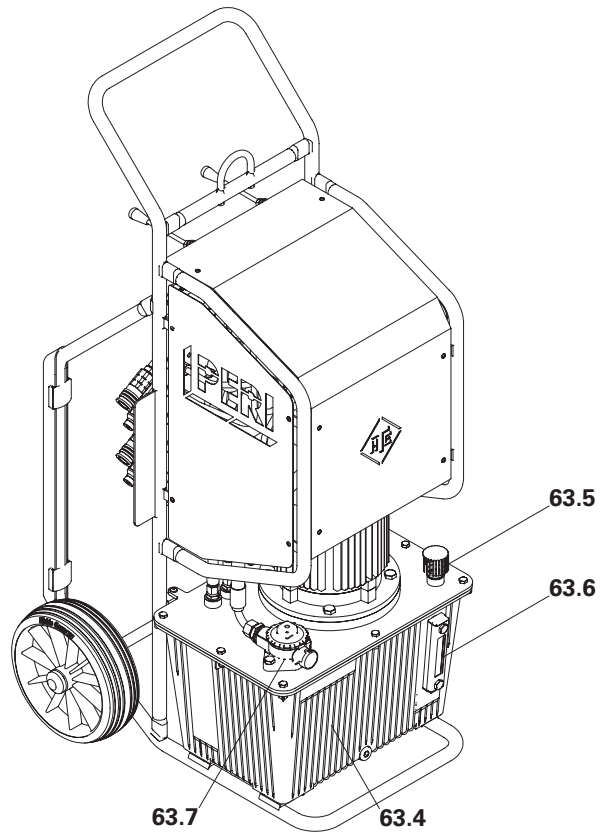

Fig. A2.03

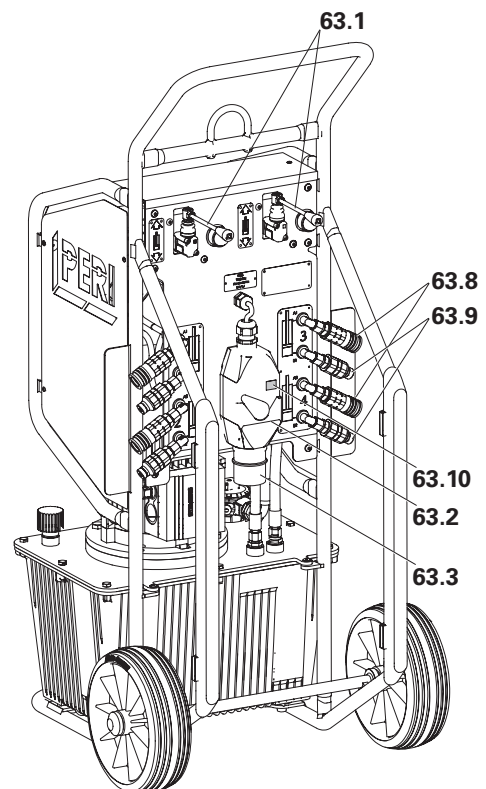

Fig. A2.03a

Accessories

(Fig. A2.04 + A2.05)

- 64** Adapter Cable RCS for supply line with CEE socket, operational voltage 380 – 400 V/16 A, 50 Hz
- 65** Coupling Socket RCS, black for mounting an adapter cable carried out by a qualified electrician. Operational voltage 380 – 460 V, 50 – 60 Hz

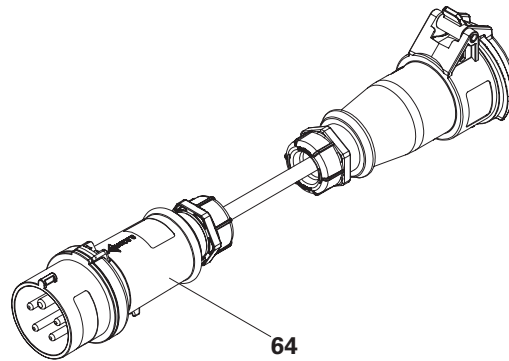

Fig. A2.04

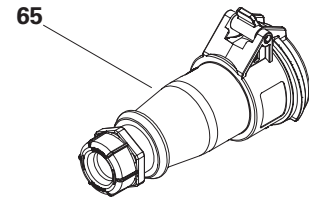

Fig. A2.05

Hydraulic hose

The hydraulic twin hose is available in lengths (**L**) of 10 m and 20 m.

(Fig. A2.06 + A2.07)

Main components

- 61** Hydraulic Twin Hose RCS 10 m
- 62** Hydraulic Twin Hose RCS 20 m
- 61.3** Hydraulic quick coupler (bushing)
- 61.4** Hydraulic quick coupler (nipple)

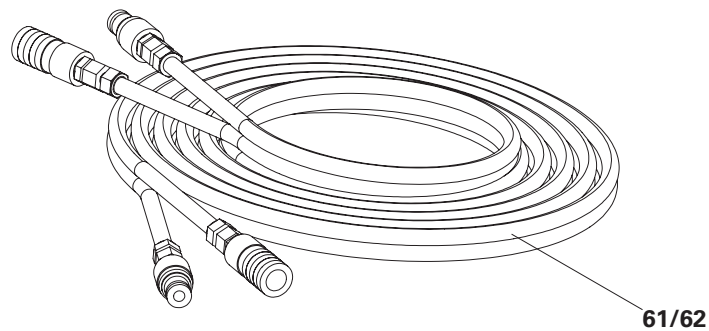

Fig. A2.06



During transport, join the two coupler ends together to protect the hoses.

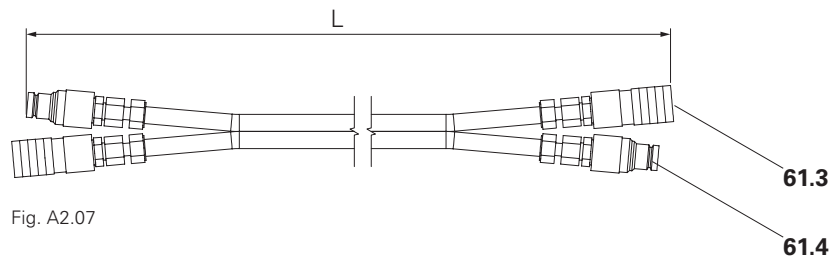

Fig. A2.07

1* safety components.

Operating states and loads

Operating status: Working

All work carried out with protection provided by the climbing protection panel and on its work platforms: assembly of the slab and column formwork, concreting and striking, inspection and maintenance.

- Platforms must be freely accessible for the required work to be carried out.
- Max. wind speed 100 km/h.

Operating status: Climbing

Moving the climbing unit by crane or by means of the hydraulic climbing device.

- Non-planned loads on the platforms are to be removed.
- Crane-assisted climbing:
Personnel are not allowed on the platforms during the climbing procedure.
- Self-climbing:
Personnel required for climbing are usually on the floor slab.
- Max. wind speed 72 km/h. (**0.25 kN/m²**).



The project-related assumed dynamic wind pressure, which was taken as basis for the design, has to be stated on the execution plan.

Live loads (if applicable)

Concreting platform	150 kg/m ²
Work platform	150 kg/m ²
Finishing platform	75 kg/m ²

Non-operational

During longer work breaks, overnight, in the case of storm warnings, with assumed or recorded wind speeds over 100 km/h.

- Accessing the platforms during storm conditions is prohibited.
- Materials and equipment are to be removed from the platforms.
- The assumed wind speed (dynamic wind pressure) during storm conditions is calculated based on the respective application height, wind zone and terrain category according to DIN EN 1991-1-4 or (EC 1).
 $q = 0.8 \text{ kN/m}^2$: $v = 129 \text{ km/h}$
 $q = 1.1 \text{ kN/m}^2$: $v = 151 \text{ km/h}$
 $q = 1.3 \text{ kN/m}^2$: $v = 164 \text{ km/h}$
 $q = 1.7 \text{ kN/m}^2$: $v = 187 \text{ km/h}$
- If given limits are exceeded, a visual inspection of all bearing components and a functional check of all safety components are necessary for further use.
- If a storm warning has higher wind speeds than originally stated, the site management has to be informed. All enclosure tarpaulins are to be removed and the climbing protection panel is to be supported by means of additional struts.
- On the instructions of authorised site personnel, the climbing protection panel can be climbed down to the previous storey. For this, additional instructions are required.
- If a storm warning with wind speeds of more than 100 km/h is assumed, additional safety measures on all corner elements are required.

Sequence of operation

The difference in the operating sequence of Variants 1 – 3 and 4 is primarily due to when the slab is struck.

All variants can be climbed using the hydraulic self-climbing device or by crane.

Variant 1 – 3

Climbing enclosure with work platform.

The slab formwork is in the way for the climbing procedure. PERI recommends a slab formwork system, e.g. SKYDECK, which allows early striking. The example shows the operating sequence with SKYDECK Slab Formwork.

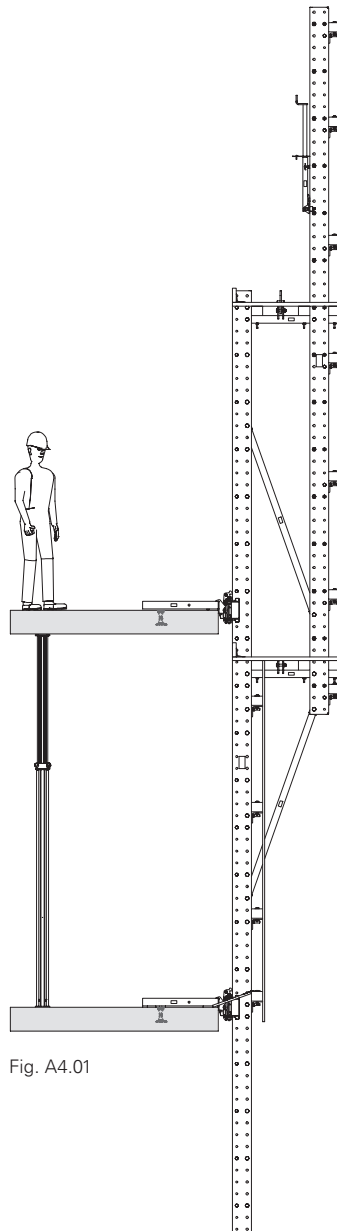

Fig. A4.01

Step 1

Climbing enclosure is in position.
Close cover flaps.
Concrete the columns.

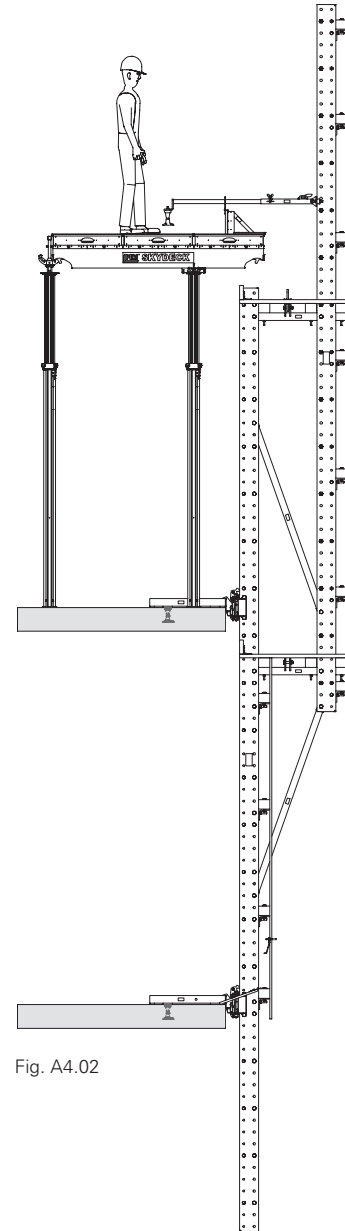

Fig. A4.02

Step 2

Erect slab formwork with stop ends.
Install leading tie with the aid of the slab tie gauge.

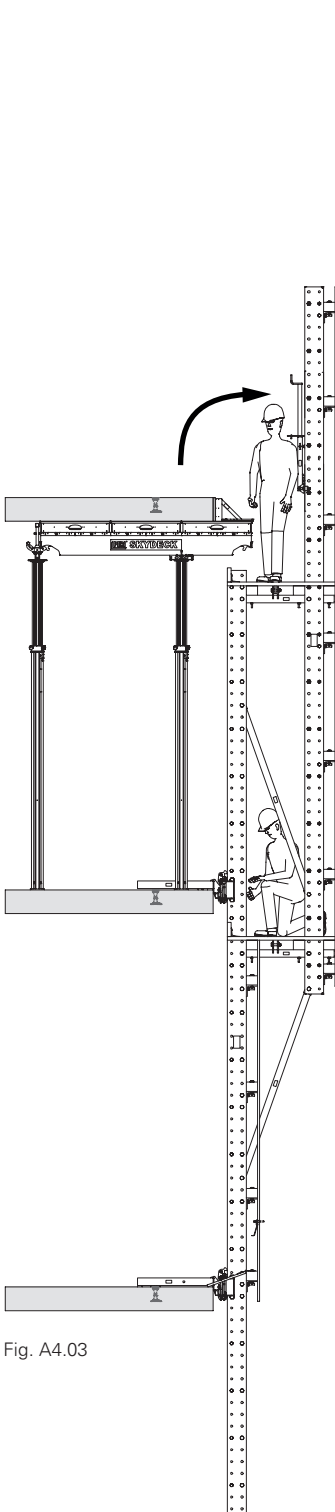

Fig. A4.03

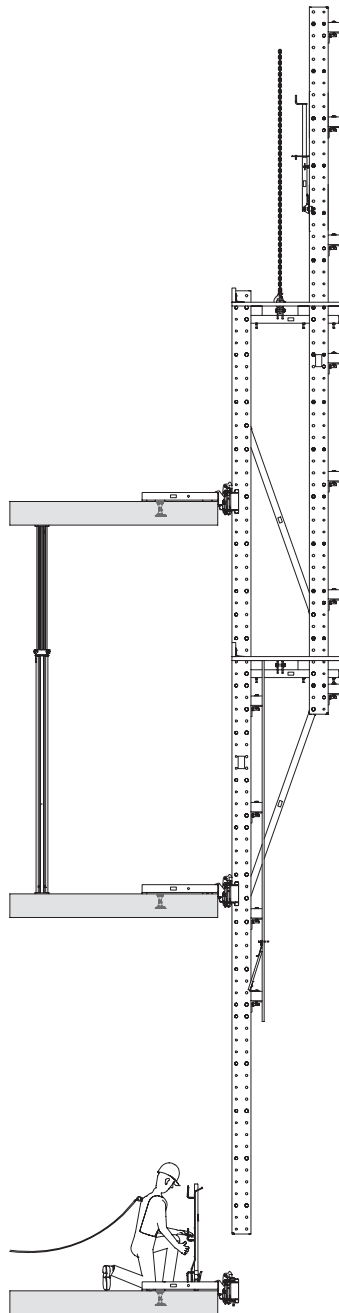

Fig. A4.04

Step 3

Concrete the slab.
 Fold up the slab tie gauge.
 Rework slab.
 Assemble subsequent guardrails.
 Dismantle the formwork.

Step 4

Fit the upper slab shoes.
 Strip slab formwork and back-prop.
 Open cover flaps.
 Climb climbing enclosure hydraulically
 or by crane (as depicted above).
 Dismantle lower slab shoes.

Variante 4

Climbing enclosure with straight protection screen.

The slab formwork can remain in position. The climbing enclosure can climb past the slab formwork.

Example

Operating sequence with shortened cycle times if two sets of SKYDECK Slab Formwork are used.

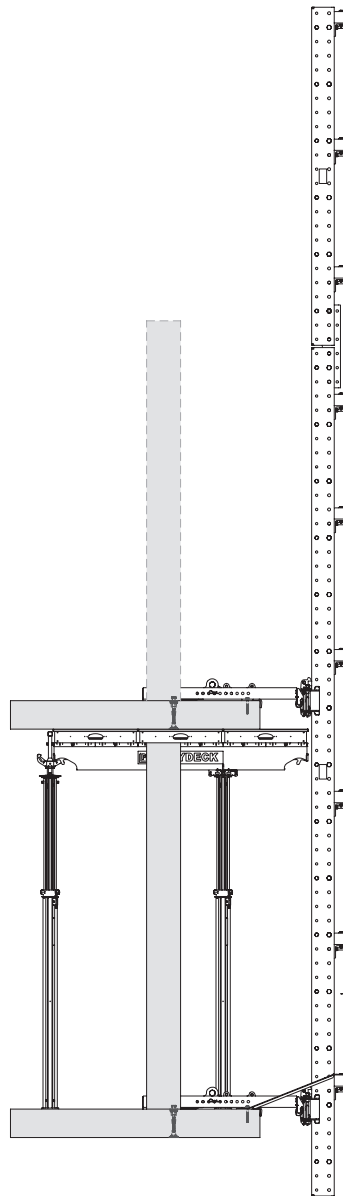

Fig. A4.05

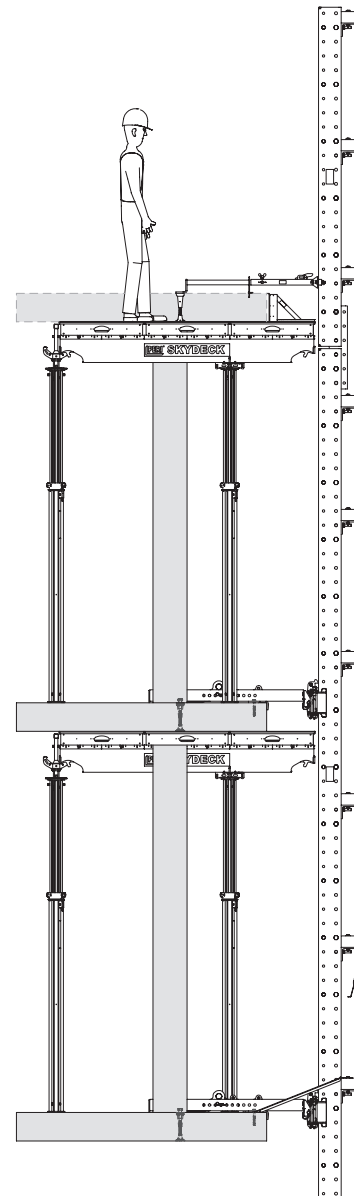

Fig. A4.06

Step 1

Climbing enclosure is in position.
Close cover flaps.
Concrete the columns.

Step 2

Erect slab formwork with stop ends.
Install leading tie with the aid of the slab tie gauge.

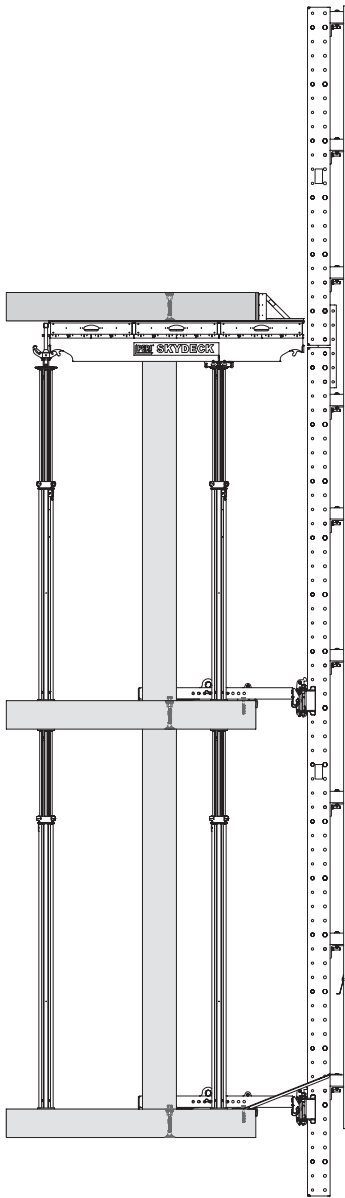

Fig. A4.07

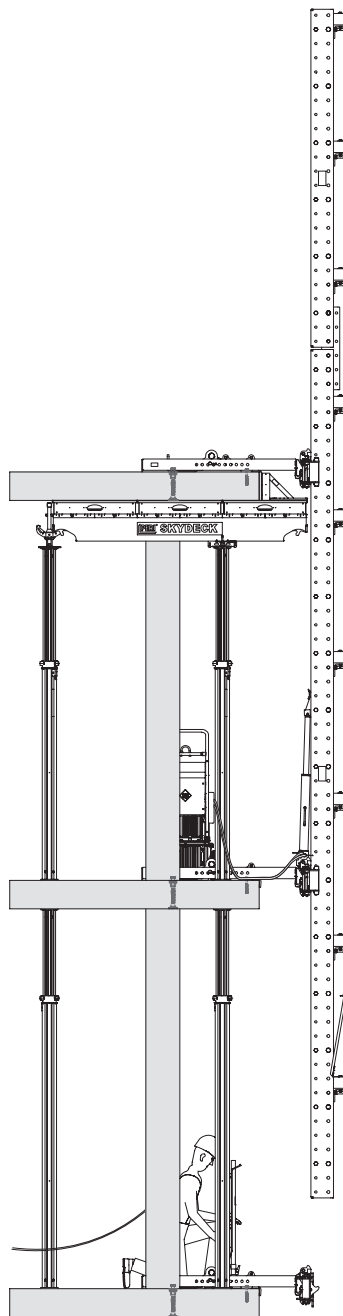

Fig. A4.08

Step 3

Concrete the slab.
 Fold up the slab tie gauge.
 Rework slab.
 Remove lower slab formwork and back-prop.
 Assemble subsequent guardrails.

Step 4

Fit the upper slab shoes.
 Open cover flaps.
 Climb climbing enclosure hydraulically (as depicted above) or by crane.
 Dismantle lower slab shoes.

System dimensions

Climbing rails

The length of the climbing rail L_1 (2) corresponds to the height of the storeys h_B .

It must correspond to at least the height of two successive storeys plus an overlap for safety reasons.

With changing storey heights, the largest dimension of two consecutive storeys must be selected.

Projecting height of the protection panel $h_p \geq 2.00$ m.



- At least 2 slab shoes must guide each climbing rail at all times.
- It is possible to plan so that the climbing rail does not overlap 2 entire storeys for those intermediate storeys with larger storey heights. In this case, self-climbing is not possible. When climbing with the crane, special measures are required because there is no climbing rail guide. These special measures must be defined in manufacturer-specific assembly instructions.



After calculation, the next largest Climbing Rail RCS must be used.

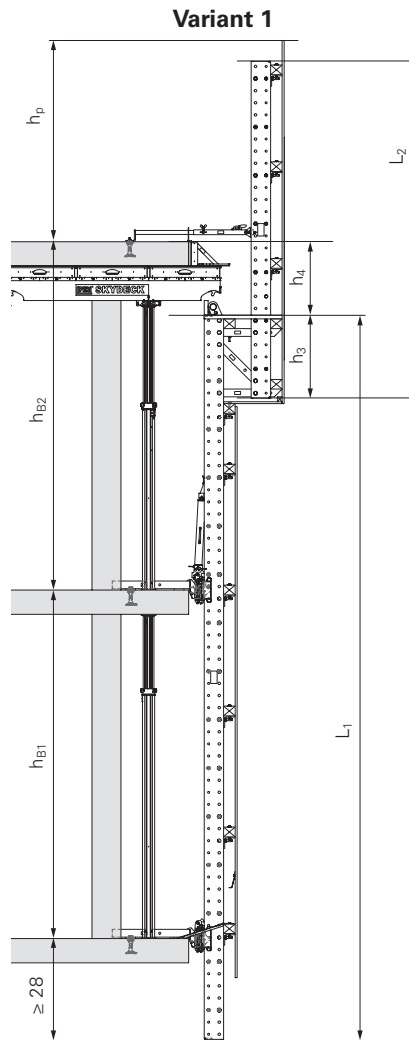

Fig. B1.01

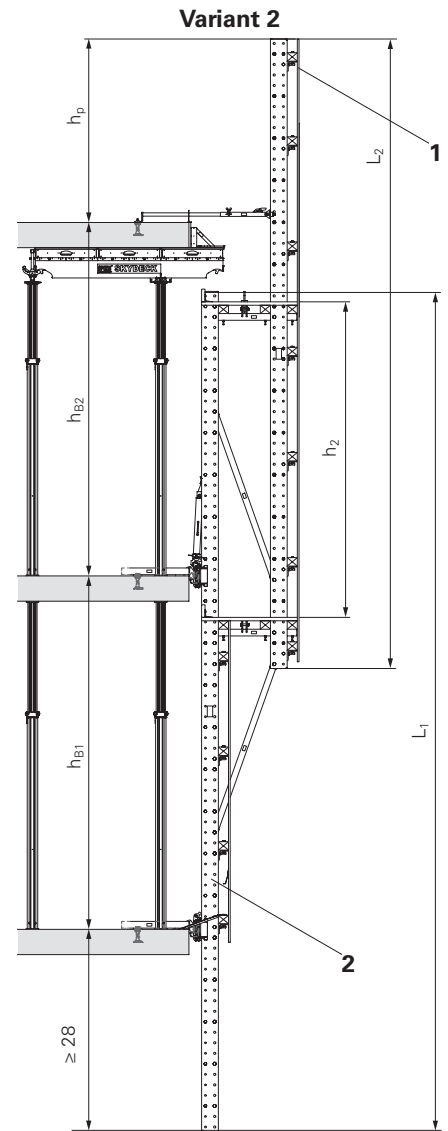

Fig. B1.02

Calculation: Variant 1

(Fig. B1.01)

Climbing Rail RCS (2).

$$L_1 \geq h_{B1} + h_{B2} + 28 \text{ cm.}$$

Enclosure Post RCS (1)

$$L_2 \geq h_3 + h_4 + h_p$$

Calculation: Variant 2

(Fig. B1.02)

Climbing Rail RCS (2).

$$L_1 \geq h_{B1} + h_{B2} + 28 \text{ cm.}$$

Enclosure Post RCS (1)

$$L_2 \geq h_{B2} + h_p.$$

Climbing rails depending on Storey height h_B

Climbing rails	max. storey heights $h_{B1} + h_{B2}$	with a constant storey height max. $h_{B1} = h_{B2}$
7.48 m	7.20 m	3.60 m
9.98 m	9.70 m	4.85 m

Tab. B1.01

Calculation: Variant 3

(Fig. B1.03)

Climbing Rail RCS (2).

$$L_1 \geq h_{B1} + h_{B2} + 28 \text{ cm.}$$

Enclosure Post RCS (1)

$$L_2 \geq h_{B2} + h_{B3} + h_p$$

Calculation: Variant 4

(Fig. B1.04)

Climbing Rail RCS (2) with projecting protection panel.

$$L_1 \geq h_{B1} + h_{B2} + h_p + 28 \text{ cm.}$$

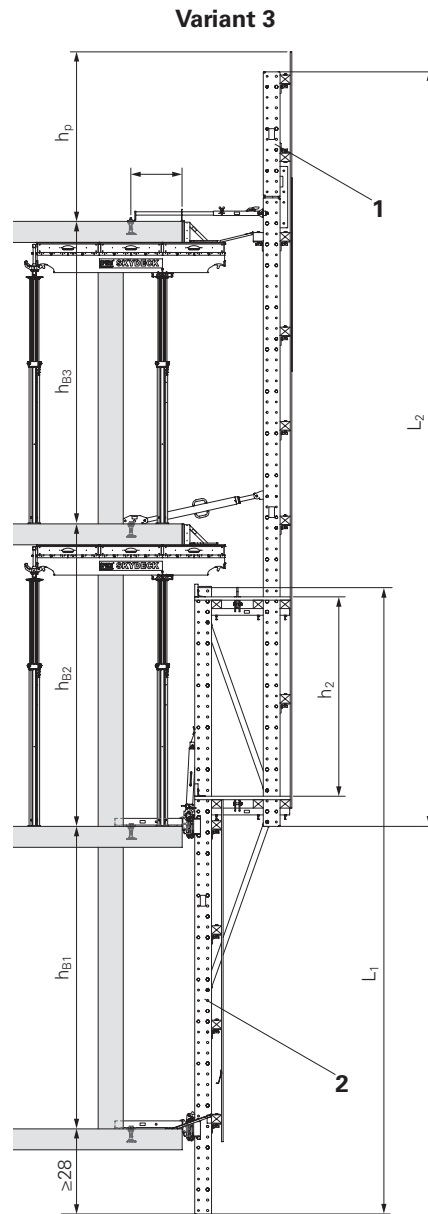

Fig. B1.03

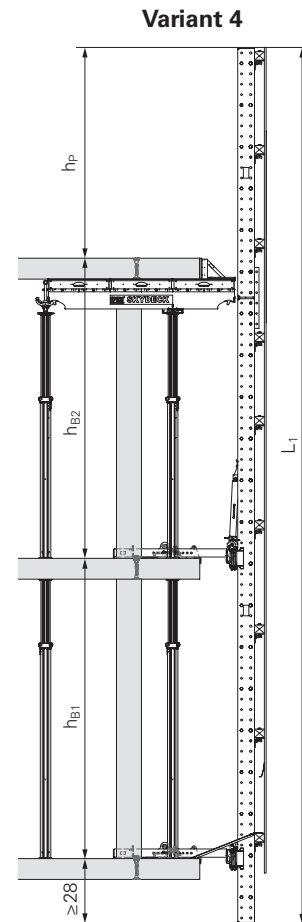

Fig. B1.04

Framework assembly

General

Depending on the assembly variant, install different framework components between the climbing rail (2) and enclosure post (1).

The bolts ISO 4014 M24 x 130-8.8 and nuts ISO 7040 M24-8 that are provided are to be used.

Climbing rail spacing

The spacing between the climbing rails is determined and proven on a project-specific basis.



The respective dimensions for the assembly are based on the specified design and must be included on separate assembly drawings. All separate fasteners that are not standard PERI components must be identified.

Variant 1

(Fig. B1.04)

Components

- | | |
|----|-----------------|
| 1 | Enclosure post |
| 2 | Climbing rail |
| 4 | Spacer M24-82 |
| 11 | Crossbar RCS 69 |

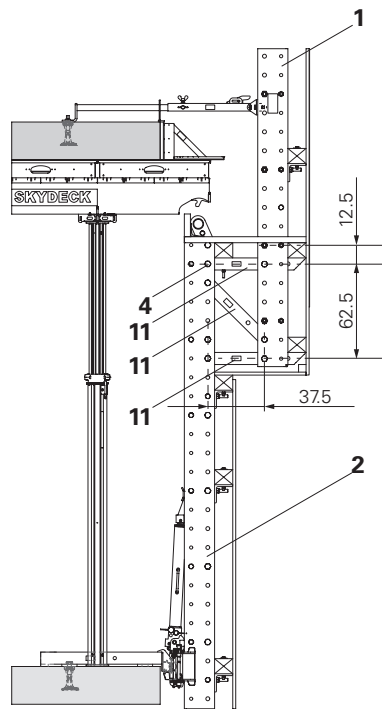

Fig. B1.04



- Offset dimension of the spacers in the climbing rail and enclosure post: 125 mm.
- The Crossbar RCS 69 is used as a horizontal platform beam and as a diagonal truss strut.
- In the arrangement shown, a spacer must be moved in the climbing rail. See Section "Additional spacers" on page 32.

Variant 2 and 3

(Fig. B1.05)

Components

- 1 Enclosure post
- 2 Climbing rail
- 10 Crossbar RCS 103
- 12 Diagonal Strut RCS 212



- No offset of the spacers (**A**) in the climbing rail and enclosure post.
- With the arrangement of the diagonal struts shown, no spacers need to be removed.

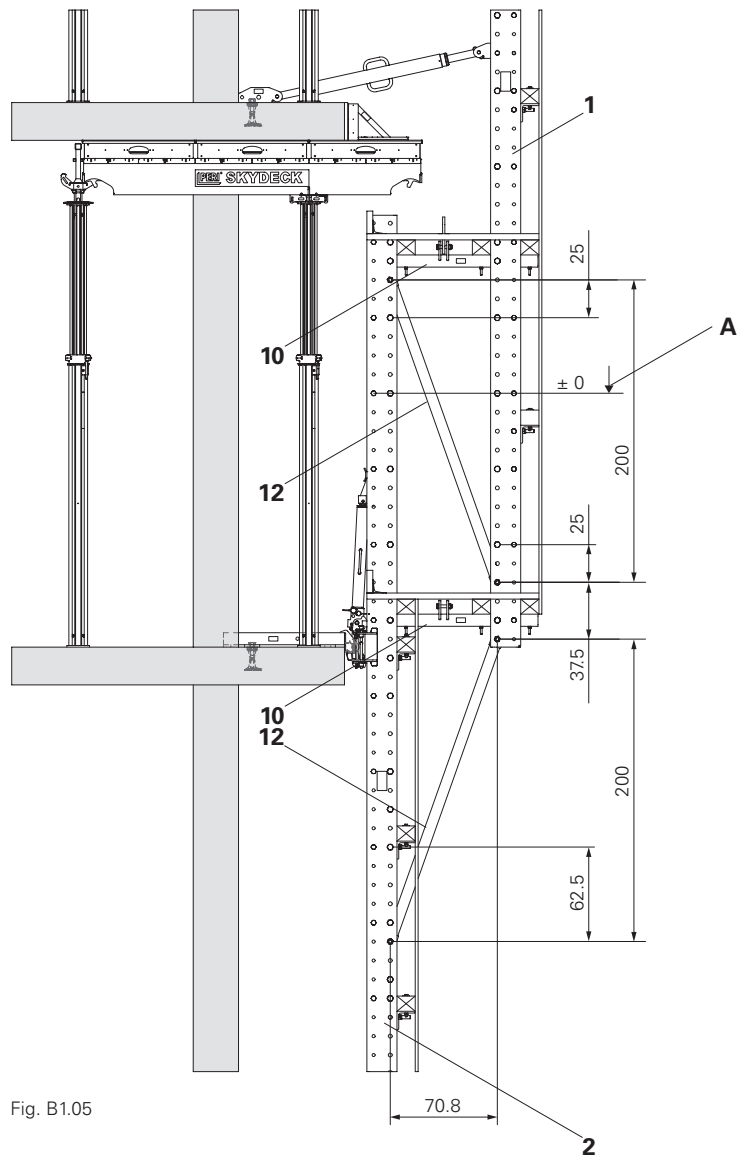

Fig. B1.05

Additional spacers

Spacers are mounted at a distance of 50 cm on the climbing rails.

Additional spacers M20-82 (**3**) can be installed on the climbing rail (**2**) as climbing bolts.

This allows the height of the climbing enclosure and work platform to be adjusted in increments of 12.5 cm.

(Fig. B1.06)

Spacers are used to support the climbing enclosure on slab shoes during working operations.



PERI recommends mounting an additional spacer M20-82 for the bottom slab shoe for standard storey heights that are multiples of 50 cm.

This ensures a definite bearing on the planned slab shoe without having to deactivate the other slab shoes.

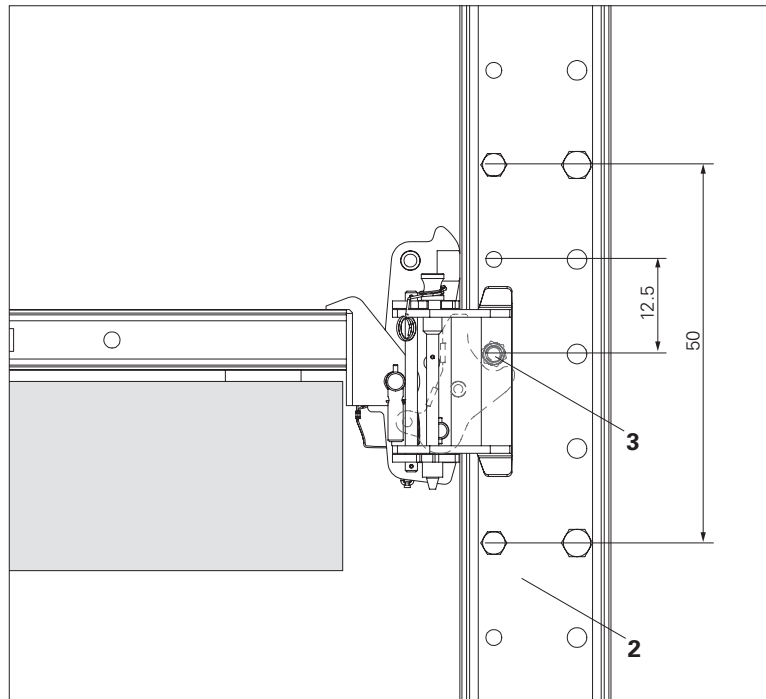

Fig. B1.06

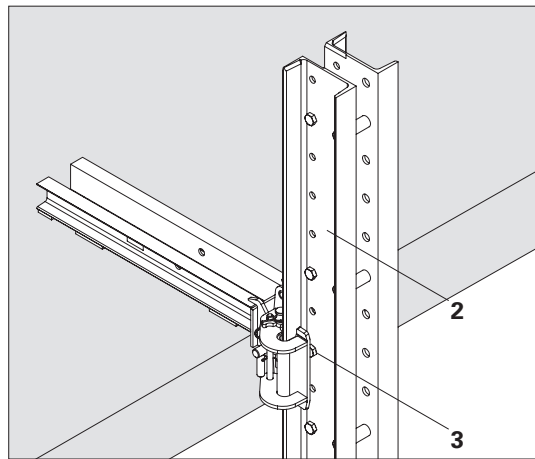

Fig. B1.07

Additional finishing platforms



Only for variants 2 and 3 with the Crossbar RCS 103. See Section A1 System Overview, Fig. A1.02 + A1.03.

Finishing platforms can be installed for work operations in the area of the bottom slab shoe.

The execution takes place corresponding to the work platforms positioned above.

Screw in additional Crossbar RCS 103 (**10**) into the climbing rail (**2**) and the extension of the enclosure post.

Components

- 1** Enclosure post
- 2** Climbing rail
- 2.3** Climbing Rail RCS 248
- 2.4** Climbing Rail RCS 348
- 10** Crossbar RCS 103
- 14** Enclosure beam (squared timber)
- 21** Climbing Rail Extension RCS 100
- 22** Climbing Rail Connector RCS 33

Variant 1

If only a short extension of enclosure post 1 is required, the finishing platform can be suspended by means of a Climbing Rail Extension 100 RCS (**21**). (Fig. B1.08)

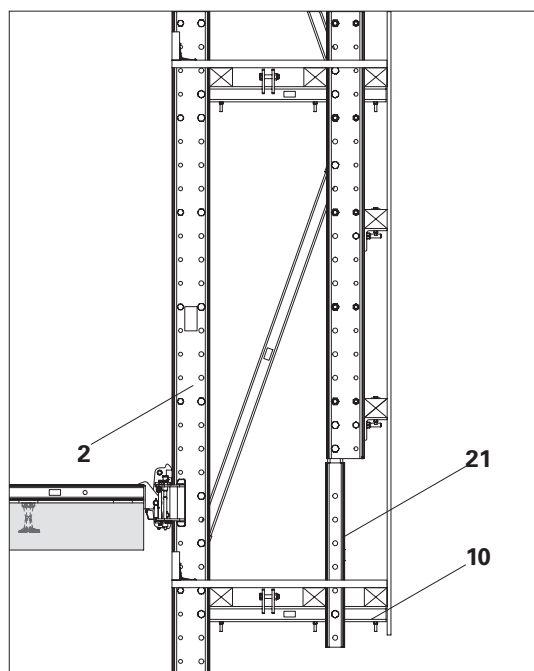

Fig. B1.08

Variant 2

To mount the enclosure post with a lower-positioned finishing platform (14), install a Climbing Rail RCS 248 (5) (L = 2.48 m) or Climbing Rail RCS 348 (6) (L = 3.48 m).

Screw the climbing rails onto enclosure post 1 with Climbing Rail Connectors R CS 33 (22). (Fig. B1.09)

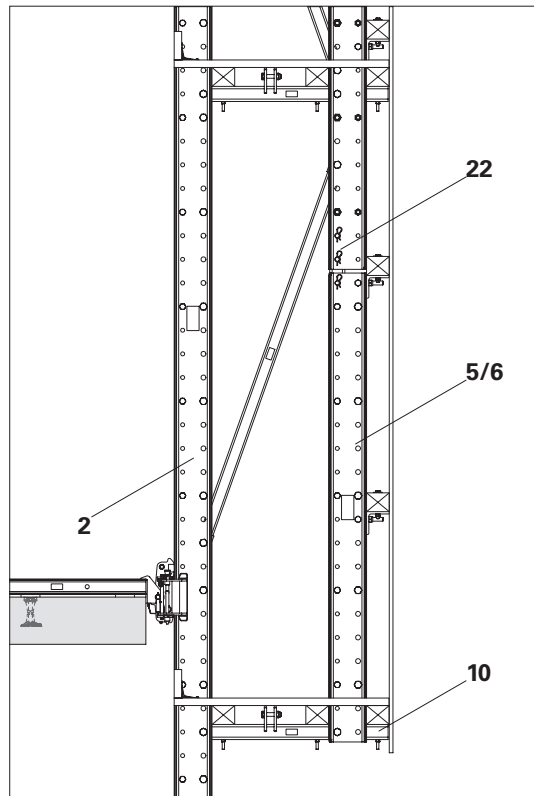

Fig. B1.09

Reaction forces

Support forces

- H_{x1} : horizontal force on the top slab shoe (positive: tension, negative: compression)
- H_{x2} : horizontal force on the bottom slab shoe (positive: tension, negative: compression)
- V : Vertical force on bottom slab shoe
- Z : Diagonal bracing force on corner elements.



PERI recommends temporary bracing of the corner elements in the case of expected wind speeds of more than 100 km/h. See Section "Bracing the corner elements" on page 110.

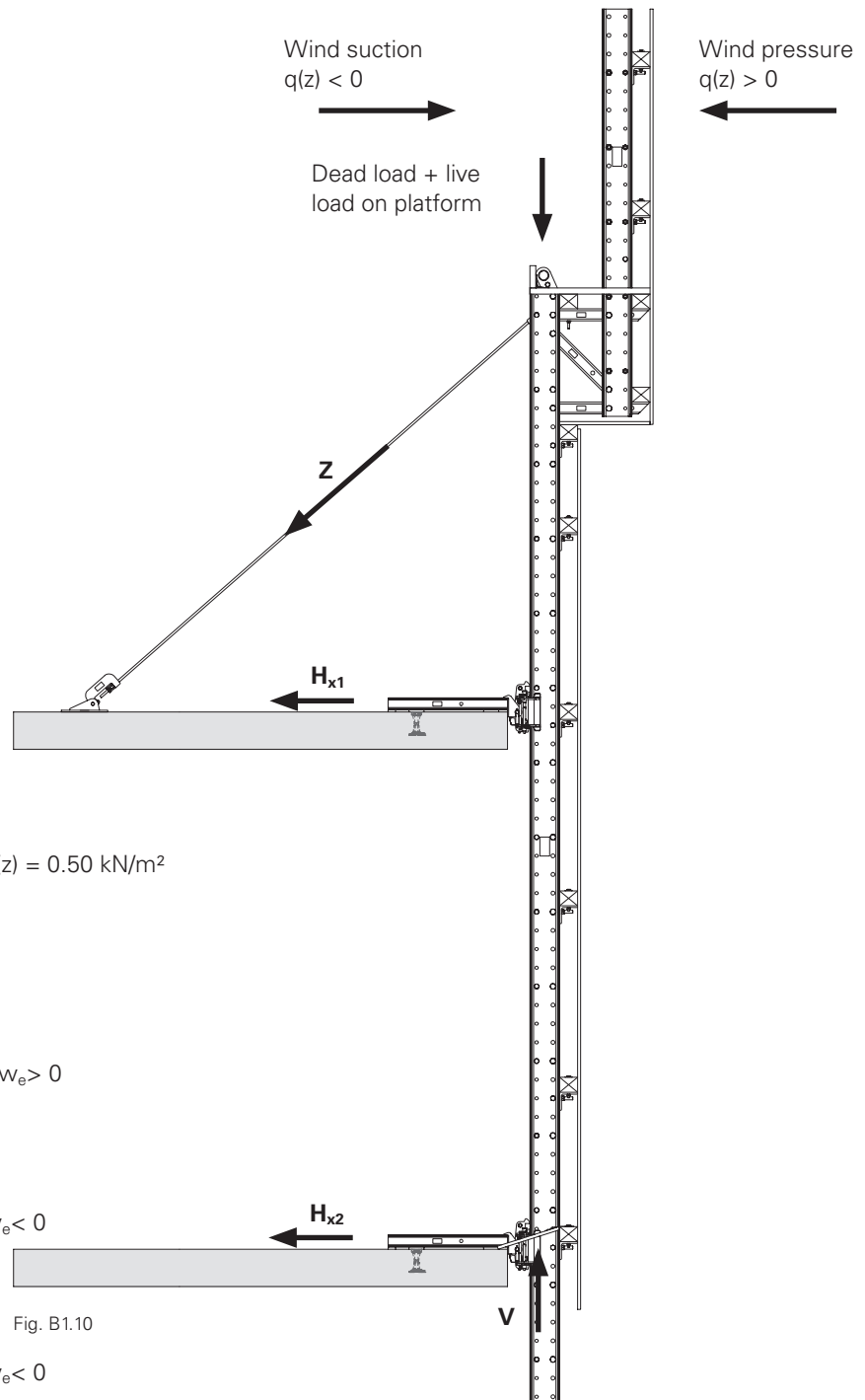

Fig. B1.10

Load cases

- A: Status: Working
Wind load from wind suction with $q(z) = 0.50 \text{ kN/m}^2$
($v = 100 \text{ km/h}$)
100% live load on one level,
50% live load on a second level.
Without bracing.
- B1: Status: Storm
max. wind load from wind pressure $w_e > 0$
no live loads
Bracing not effective ($Z = 0$)
- B2: Status: Storm
max. wind load from wind suction $w_e < 0$
no live loads
Bracing is effective ($Z > 0$)
- B3: Status: Storm
max. wind load from wind suction $w_e < 0$
no live loads
Corner elements with bracing ($Z > 0$)

- $w_e = q(z) \times \chi \times c_p$
- $= q(z) \times \chi \times c_t$
- $q(z)$ = peak velocity pressure
- c_p = aerodynamic pressure coefficient
- c_t = aerodynamic force coefficient
- χ = service life factor for temporary constructions

Tie forces

H_x : horizontal force on the slab shoe
(positive: tension, negative: compression)

V : Vertical force on slab shoe

V_{Ax} : Tie shear force

N_A : Tie tensile force

P_c : Support force of the slab
If the concrete slab is not sufficiently stable, then a slab prop, e.g. MULTIPROP, is to be installed under the slab to provide load relief.

(Fig. B.1.11)

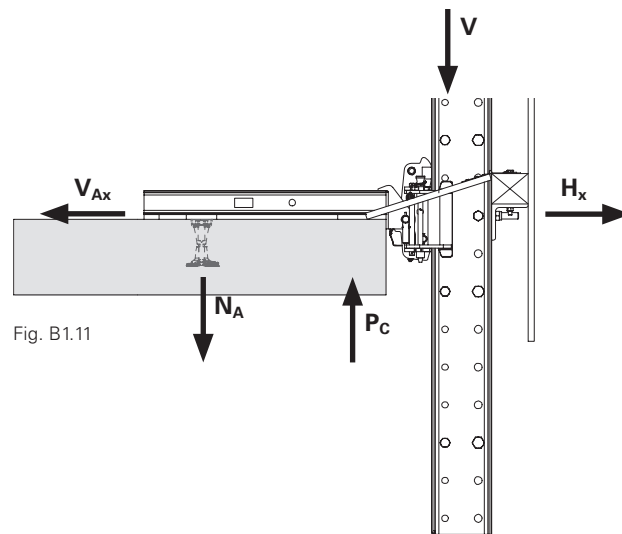

Fig. B.1.11



Slab props that have already been installed may fall over due to unscheduled load relief of the slab. Secure slab props against falling over especially on the edge of the structure.



Take into consideration PERI expert information “Design Chart for RCS Climbing Protection Panel”!

- The load-bearing capacity of the Slab Shoe RCS and anchoring must be verified separately.
- The load-bearing capacity of the anchoring depends on the type of tie, anchoring depth, edge distances and the concrete strength. Deviating conditions may require the installation of additional back-draft reinforcement or reinforcement for the edging.
- The contractor is responsible for the correct transfer of the reaction forces into the building structure.

Suspension with the slab shoe



Observe torques from Table "Tightening torques" on page 15 .

Suspension overview

- 2 Climbing Rail RCS
- 3 Spacer M20-82
- 44 Climbing Shoe RCS
- 45 Slab Shoe RCS
- 45.1 Locking pin
- 45.2 Bolt ISO 4014 M24 x 70-10.9
- 47 Anchoring
- 54 Slab Tie Gauge 61 RCS

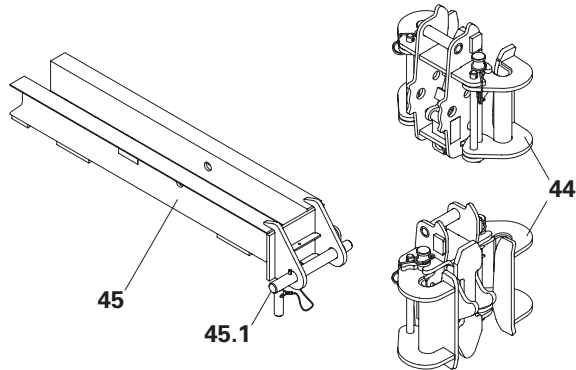

Fig. B1.12

Tie fastening

There are 3 possible variants of anchoring M24:

Variant 1

Screw-On Cone M24/DW 20

Variant 2

Anchor Sleeve M24

Variant 3

Climbing Cone-2 M24/DW 15

Tie spacing to slab edge:

$a_D = 600 \text{ mm}$

Leading ties (47) are fixed in their respective position during concreting by means of the Tie Locating Point M24 of the Slab Tie Gauge RCS (54).

The slab tie gauge with the support plate rests on the stop end formwork.

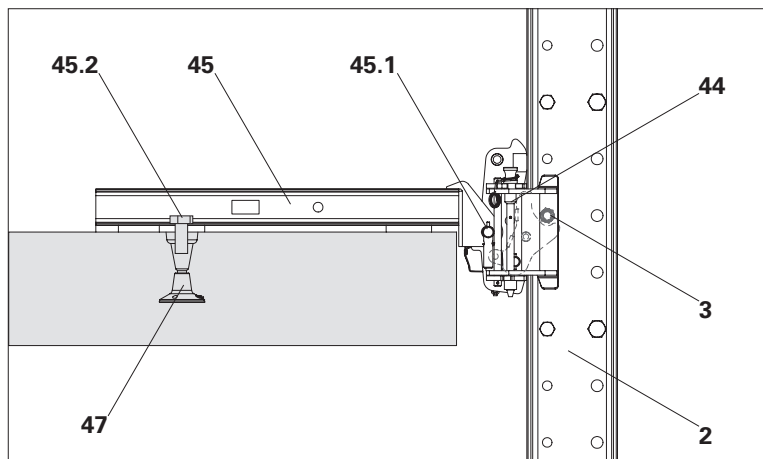

Fig. B1.13



The stop on the support plate creates an impression in the concrete.

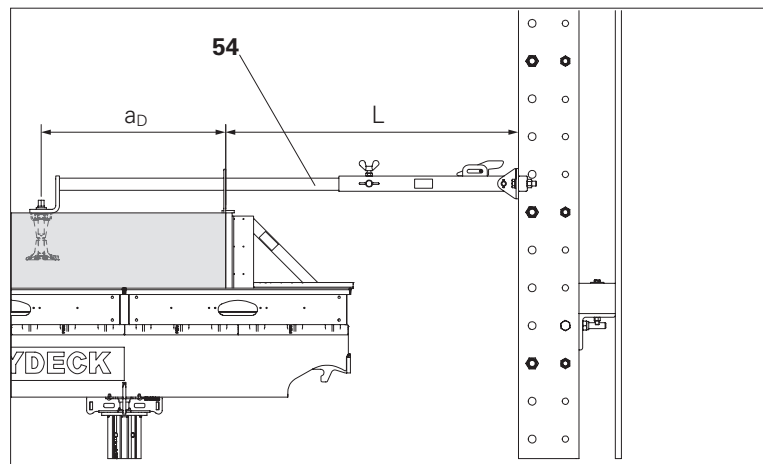

Fig. B1.14

Anchoring

Variant 1:

with Screw-On Cone M24/DW 20.
(Fig. B1.15)

Components

47.1 Screw-On Cone-2 M24/DW 20

47.2 Threaded Anchor Plate DW 20

Approval No. Z-21.6-1766
or expert opinion for the
PERI Climbing Tie.

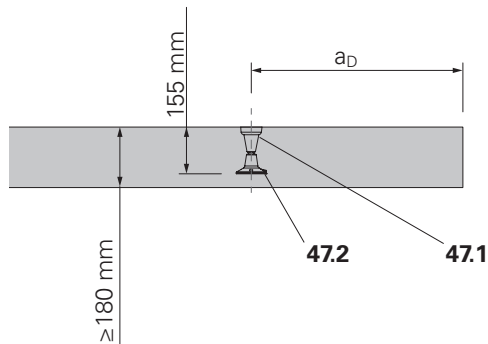

Fig. B1.15

Variant 2:

with Climbing Cone-2 M24/DW 15.
(Fig. B1.17)

Components

47.5 Climbing Cone-2 M24/DW 15^{1*}

47.6 Tie Rod DW 15^{1* 2*} or

Tie Rod B 15^{1* 2*}

$$L_S = h_{nom} - 80 \text{ mm}$$

47.7 Threaded Anchor Plate DW 15^{1* 2*}
Ø 80 mm

Approval No. Z-21.6-1767
or expert opinion for the
PERI Climbing Tie

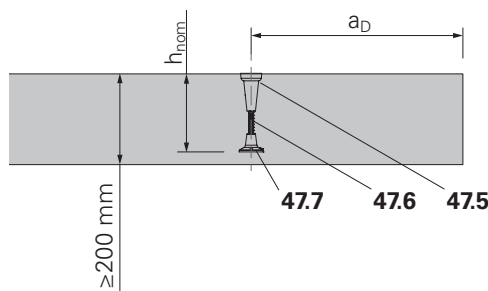

Fig. B1.17

^{1*} All suspension and anchoring parts
are safety components.

^{2*} Non-reusable components.

Variant 3:

with Climbing Cone-2 M24/DW 15. completely re-usable. (Fig. B1.18)

Components

475 Climbing Cone-2 M24/DW 15 ^{1*}
 $h_{nom} = h \geq 185 \text{ mm}$

476 Tie Rod DW 15 ^{1*}
 or Tie Rod B 15 ^{1*}
 $L_S = h_{nom} - 80 \text{ mm}$

477 Threaded Anchor Plate DW 15 ^{1*}
 $\varnothing 80 \text{ mm}$, nailed for positioning on the slab formwork

478 Spacer Tube $\varnothing 22$,
 $L_T = h - 185 \text{ mm}$ ^{2*}

Approval No. Z-21.6-1767
 or expert opinion for the PERI Climbing Tie.

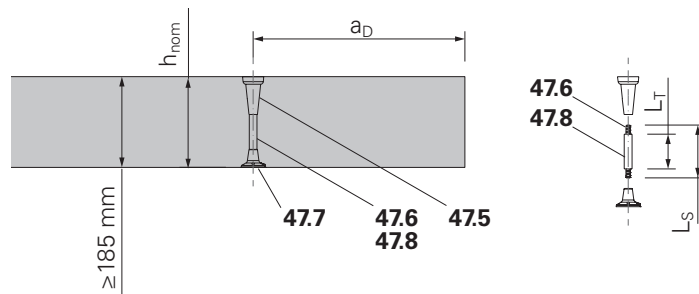

Fig. B1.18

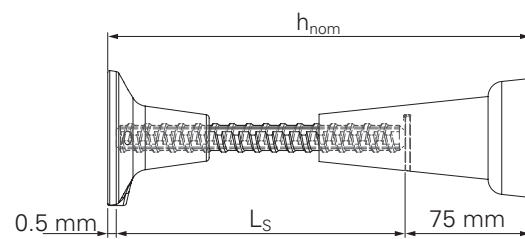

Fig. B1.18a



- With Tie Rod B15 (with circumferential thread), the load-bearing capacity of the anchoring may be lower than with the Tie Rod DW15 (with interrupted thread)! For this, see building authority approval or corresponding product information
- Fixing the threaded anchor plate to the slab formwork is not allowed especially with architectural concrete.

^{1*}All suspension and anchoring parts are safety components.

^{2*} Non-reusable components.

Suspension with the stop end slab shoe

For installing a stop end slab shoe during the assembly of the stop end slab shoe.

Components

- 44** Climbing Shoe RCS
- 48** Stop End Slab Shoe RCS
- 48.1** Locking pin 25 mm

Stop End Anchoring M30

Components

- 49** Bolt ISO 4017 M30 x 70-8.8
 - 51** Stop End Slab Tie M30/25-160
- Alternatively:
- Climbing Cone-2 M30/DW 20
 - Tie Rod DW20 or B20
 - Threaded Anchor Plate DW20

Stop End Anchoring M24

Components

- 53** Bolt ISO 4014 M24 x 70-10.9
 - 50** Reducing bushing Ø 30 - 25
 - 52** Stop End Slab Tie M24/20-128
- Alternatively:
- Climbing Cone-2 M24/DW15
 - Tie Rod DW15 or B15
 - Threaded Anchor Plate DW15

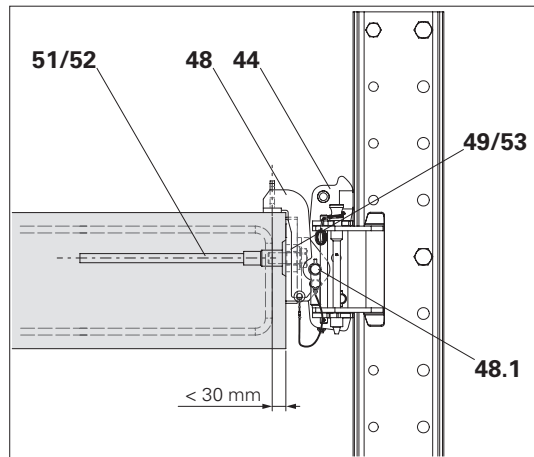

Fig. B1.19

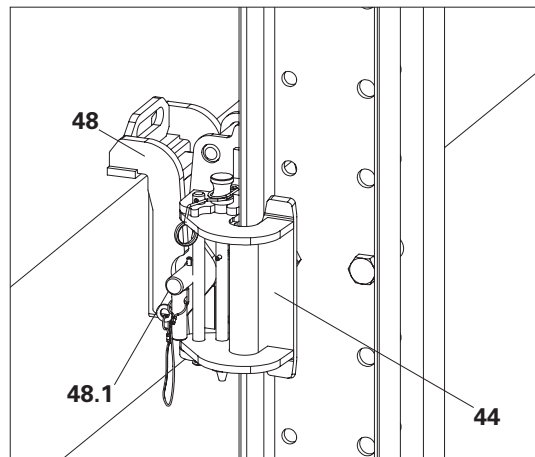

Fig. B1.20

Horizontal support

The climbing protection panel variant 3 requires additional horizontal support given the enclosure is spread over 2 storeys.

Fit the heavy-duty spindle on the enclosure post with one fitting pin $\varnothing 21$ mm and fitting pin $\varnothing 26$ mm respectively. Use the anchoring on the slab which will subsequently carry the slab shoe. Permissible angle of inclination $\alpha = 10 \pm 5^\circ$

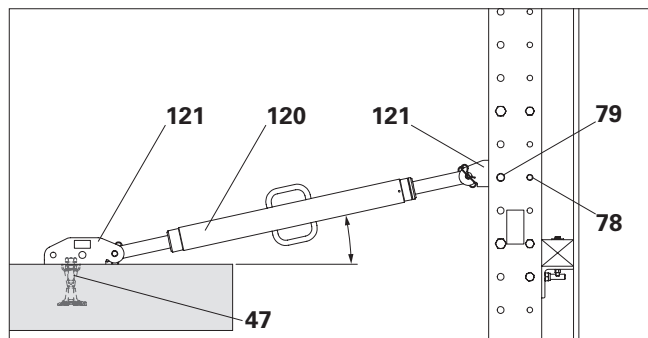

Fig. B1.21

Components

- 45.2** Bolt ISO 4014 M24 x 70-10.9
- 47** Anchoring
- 78** Fitting pin $\varnothing 21$ mm
- 79** Fitting pin $\varnothing 26$ mm
- 120** Heavy-Duty Spindle SLS 100/180
- 121** Spindle Shoe SLS/RCS M24

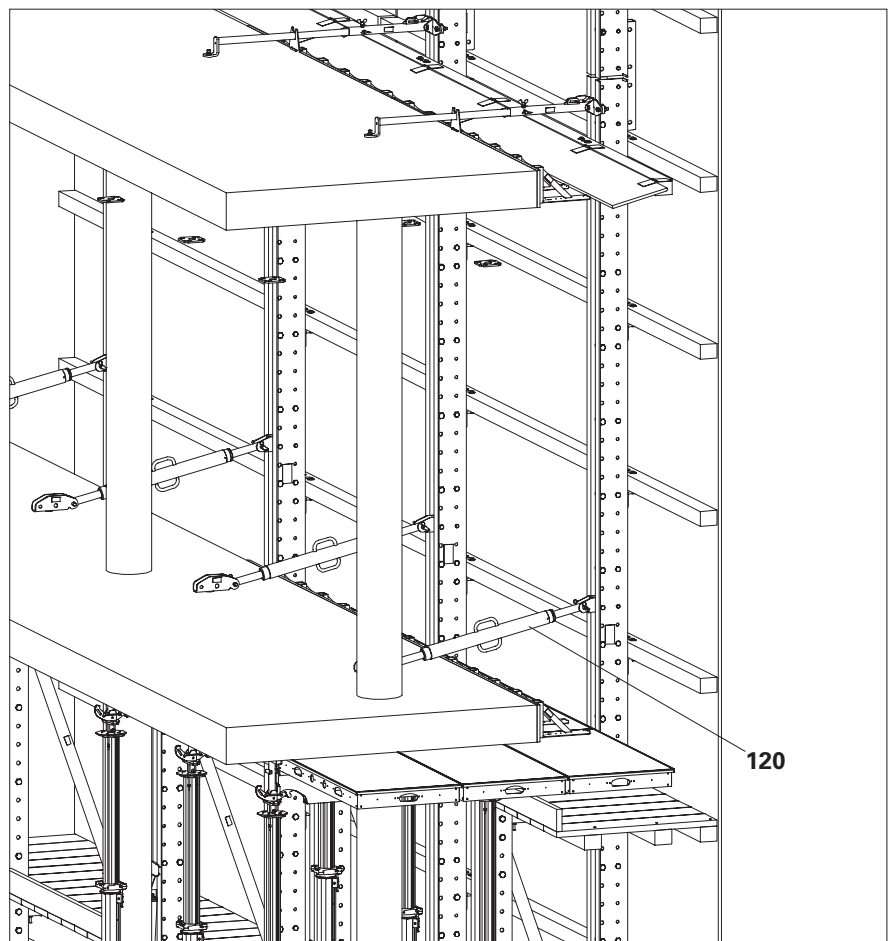

Fig. B1.22

Upper slab formwork not shown

General

Keep the following points in mind when planning the climbing sequence and putting together the work instructions:

- Form the decks, especially on corner and internal platforms, in such a way that they do not collide with the platforms or adjacent climbing enclosures during the climbing process.
- If overlapping components are planned between the climbing enclosures, then the climbing sequence is to be planned accordingly and be clearly indicated on the general arrangement drawings. Overlapping components are, for example, covering for the gaps between the climbing enclosures.
- Plan access and ladder descents in such a way that there is safe access to all climbing units at all times.
- The climbing sequence must be planned for the entire building. Suitable installation of the hydraulic hoses and climbing of the last climbing unit must to be determined accordingly.
- When climbing by crane, always provide safe access for attaching and detaching the crane lifting gear. Additional two-sling lifting gear that remains on the climbing enclosure may be necessary until it can be safely removed.
- A hydraulics plan shows how the climbing devices are to be correctly attached to the hydraulic units with the hydraulic hoses.
- Specify appropriate measures to cord off or secure the open building edges that appear.

Attachment point for crane

The size of the climbing enclosures can be limited by the permissible load of the attachment point on the Crossbar RCS. For this, determine the weight of the relevant panels during the planning phase.

When assembling and dismantling climbing enclosures that are moved with the self-climbing device, also observe the permissible load of the attachment points.

The weight G of the climbing units is to be specified in the general arrangement drawings.

Standard case:

Attachment point with Lifting Eye BR 2.5 t (8) Platform beam (40) as compression brace (Fig. B2.01)

Components

- 8** Lifting Eye BR-2 2.5 t
- 10** Crossbar RCS 103
- 40** Platform beam (squared timber)



- Always lift and move climbing units with Climbing Beam RCS 9t.
- For safe attachment and removal of the crane hook, provide suitable measures to prevent falls.
- Permissible load per Lifting Eye BR 2.5 t: max. 25 kN.
- Crane sling angle $\alpha \geq 60^\circ$.
- With heavy climbing units where a load of more than 25 kN per attachment point must be lifted, attach the PERI Climbing Beam RCS 9t to a spacer. (Fig. B2.01)
 - Observe the relevant Instructions for Use.
 - Ensure loads are evenly balanced when they are picked up.

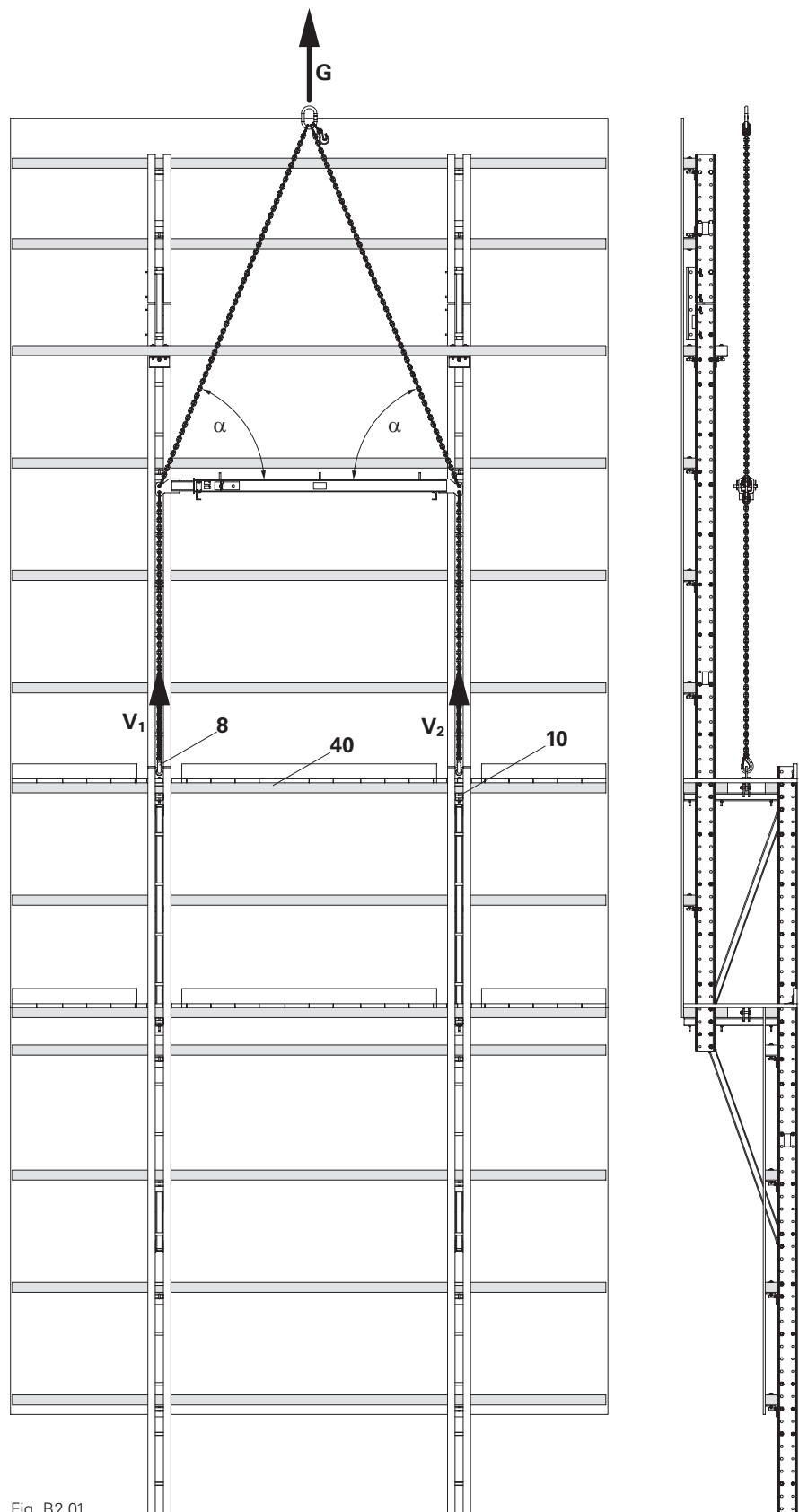

Fig. B2.01

Planking

Platform planking

Working scaffold of Load Class 2
max. load 150 kg/m² according to
DIN EN 12811-1

Solid Wood Strength Class C24 –
EN 338 (Coniferous Wood Grade S10).
Minimum dimensions of the planking:
 $b \times d = 24 \times 4$ cm

Dimension B depends on the dimen-
sions of the platform beams (40) as
well as the overhang of the deck above
the climbing rails.

Alternatively:

Solid Wood Strength Class C16 –
EN 338 (Coniferous Wood Grade S7).
Minimum dimensions of the planking:
 $b \times d = 24 \times 5$ cm

For use as **safety scaffold** for heights
up to 3.00 m, decking with planks $w \times$
 $d = 24 \times 4.5$ cm is required – see
DIN 4420-1

Toe boards:

Toe boards made of Solid Wood C24
(coniferous wood S10).
Minimum dimensions:
 $w \times d = 3 \times 15$ cm.



When using planking with a lower
strength class or plywood boards,
static verification is required!

Components

- 1 Enclosure post
- 2 Climbing rail
- 8 Lifting Eye BR-2 2.5 t
- 37 Work platform decking (planks)
- 39 Toe board
- 39.1 Angle Connector 90° reinforced
- 40 Platform beam (squared timber)
- 98 TSS-Torx 6 x 80

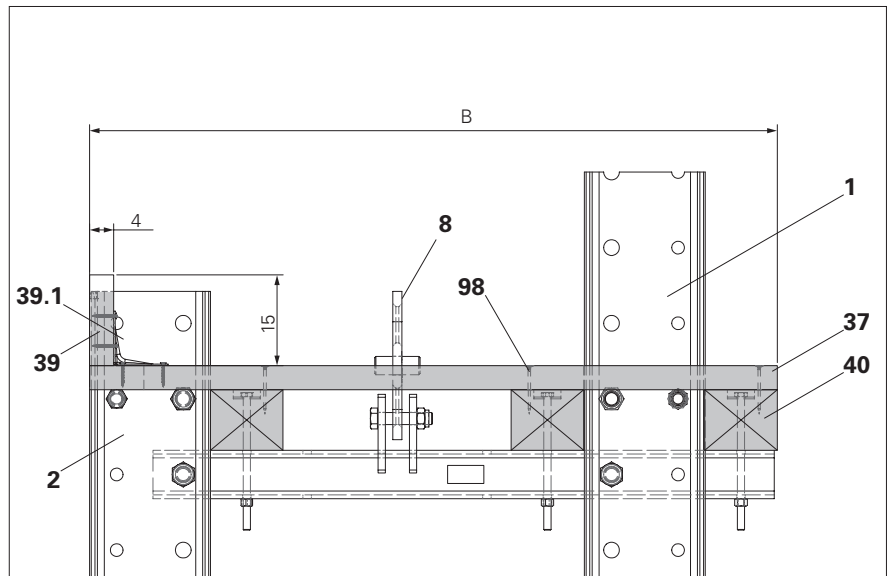

Fig. B2.02

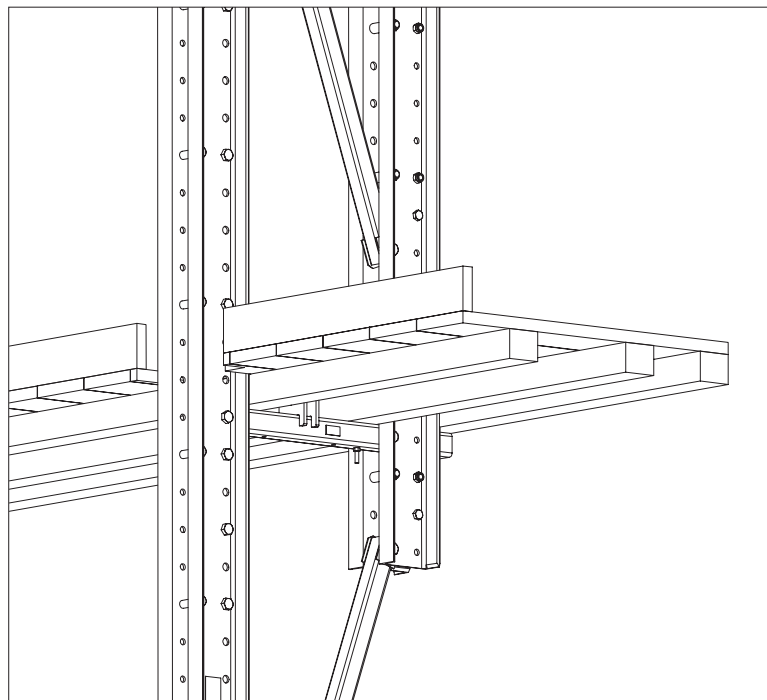

Fig. B2.03

Deck support

The platform beams (squared timbers) are dimensioned and proven on a project-specific basis.

Solid wood strength class C24 – EN 338 (Coniferous Wood S10).
Max. width of influence (e_B) of the platform beam: 0.50 m

Work platform load according to Scaffold Group 2:
Max. live load 150 kg/m²
Max. cantilever $d \leq 0.5 c$

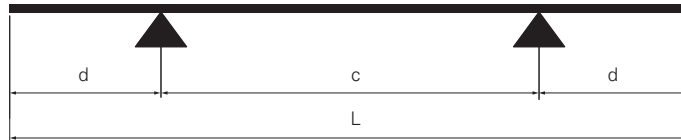

Fig. B2.04

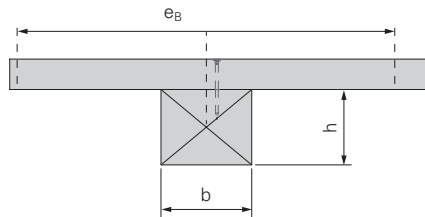

Fig. B2.05

To protect workers from falling objects

The enclosure and platforms should completely enclose the working area. Openings > 20 mm are to be covered in a non-displaceable manner or filled with installation foam.



- Setting down and storing materials and tools on the coverings is prohibited.
- Foldable covers are not decking surfaces and are planned as areas not to be walked on or subjected to loads.
- Take into account the fibre direction (**F**) of the surface layer! (Fig. B2.06a)

Securing the slab edge

In the area of the lower storey slab, mount multi-layer plywood sheeting (**41**) on the enclosure beam (**14**) by means of hinges (**42**). Screw on chamfered squared timber (**14.1**) to support the cover flap.

Alternatively, mount the scaffolding tube (**80**) on the climbing rail by means of the scaffold tube holder (**137**). Mount foldable covers (**41**) using flap hinges (**138**) and flap safety plates (**139**).

Cover any remaining gaps in the area of the slab shoe with Cover Mat RCS 70x70 (**43**).

Components

- 14** Enclosure beam (squared timber)
- 41** Foldable cover (multi-layer plywood sheeting)
- 42** Hinge DIN 7957-200-ST
- 43** Cover Mat RCS 70 x 70
- 80** Steel scaffolding tube Ø 48.3 x 3.2
- 137** Scaffold Tube Holder Ø RCS
- 138** Flap Hinge LPS D48/M10
- 139** Flap Safety Plate LPS D=48 RCS

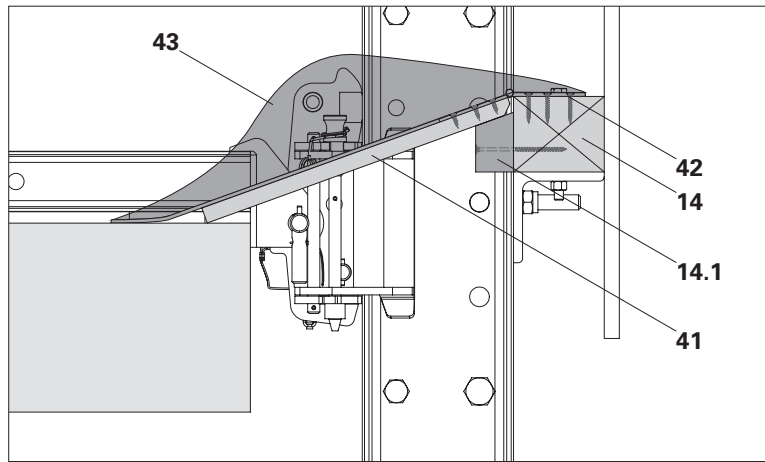

Fig. B2.06

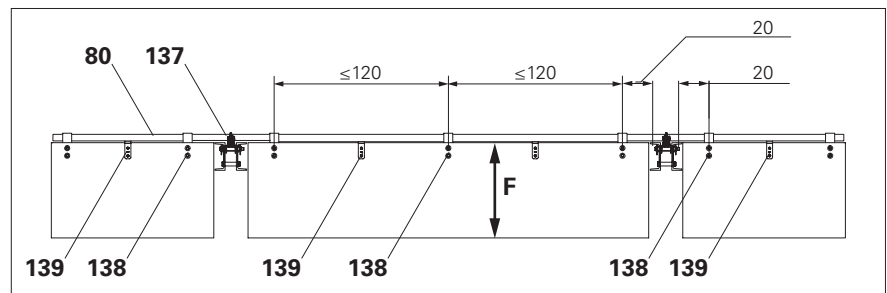

Fig. B2.06a

Flap material:	Untreated plywood ≥ 20 mm
Permissible inclination:	10°– 30°
Permissible depth:	≤ 0.75 m
Hinge spacing:	≤ 1.20 m, at least 2 hinges per flap
Hinge spacing to climbing rail (2):	≤ 20 cm

Tab. B2.02



PERI recommends a distance between the climbing units of 50 mm.

Cover gaps between the climbing units in a non-displaceable manner in the working state, e.g. with:

- boards that are screwed on and that are removed or folded up during climbing.
- Alternatively, gaps can be covered with rubber lips.



In order to ensure a simple moving procedure with the crane without jamming the enclosure beams (**14**), protection edges (**20**) can be arranged on the front side. The width (b_1) depends on the design of the enclosure with multi-layer plywood sheeting (**18**) or trapezoidal metal sheets (**19**).

Components

- | | |
|-----------|--|
| 14 | Enclosure beam (squared timber) |
| 18 | Enclosure (multi-layer plywood sheeting) |
| 19 | Enclosure (trapezoidal metal sheeting) |
| 20 | Protection edge |

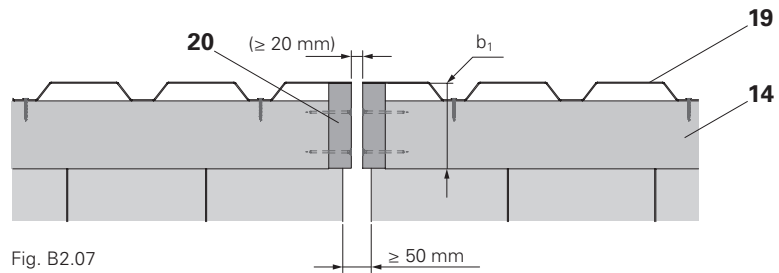

Fig. B2.07

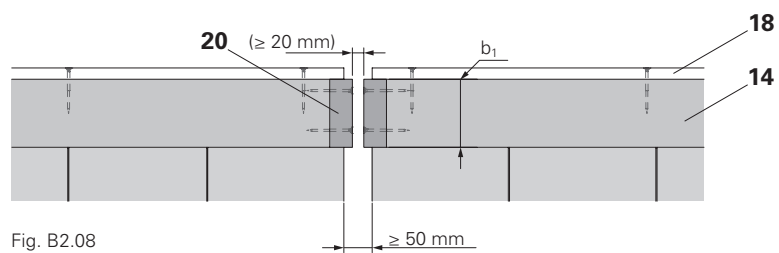

Fig. B2.08

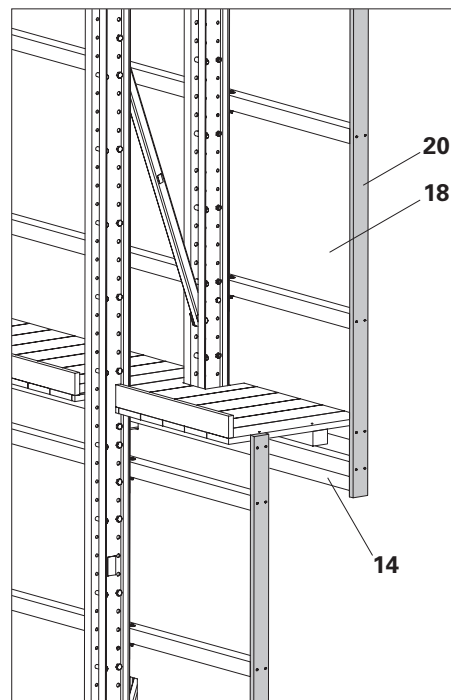

Fig. B2.09

Guardrails

Guardrails and lateral protection must be fitted according to valid safety regulations!

Guardrails must be fitted onto all leading edges and on all platform levels.

High working positions must be secured in order to prevent objects falling to the ground. To this end, fit safety nets or lateral protection with closed protection panels.

The following can be used as lateral protection:

- Handrail boards
- Galvanised steel scaffolding tubes $\varnothing 48.3$ or $\varnothing 60.3$
- Squared timbers with enclosure made of netting, tarpaulin, plywood or trapezoidal metal sheeting

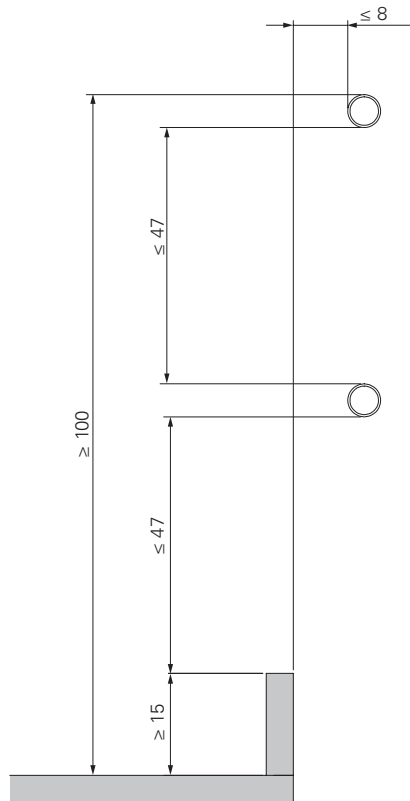

Fig. B2.10

Ladder cage with scaffolding tubes

Requirements:

Steel scaffolding tubes **(80)**, minimum quality St37-2.

Dimensions $\varnothing \times t = 48.3 \times 3.2$ or 60.3×4.5 mm

Fixing:

Clamp A64 DIN 3570 **(81)**

Hex. Nut ISO 4032 M12-8 **(82) (2x)**

Mount scaffolding tubes on inner side, with netting or tarpaulin also on the outer side with spacing of $a = 50$ cm.

Max. cantilever $d \leq 0.5 \times c$
(Fig. B2.11)

At the ends and in the middle of the span the scaffolding tubes are to be connected to each other using vertical scaffolding tubes or supported to prevent any overloading.

Components

80 Steel scaffolding tube $\varnothing 48.3 \times 3.2$

81 Clamp A64 DIN 3570

82 Hex. Nut ISO 4032 M12-8

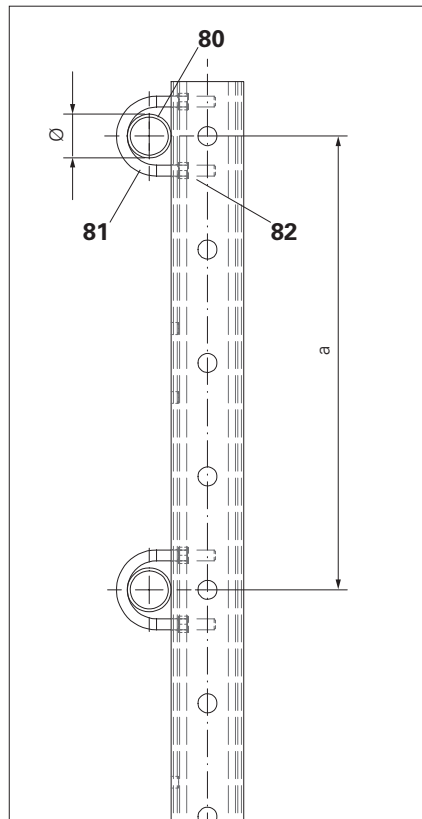

Fig. B2.11

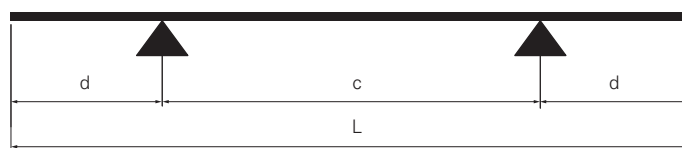

Fig. B2.12

Enclosure

Requirements for enclosure beams:

Squared timbers (**14**) made of Solid Wood C24 (Coniferous Wood S10).
 Dimensions w/h = 12/10, 12/12, 14/10, 14/14, 15/7.5 cm or 15/15
 Spacing a and span according to static proof. Mount the squared timbers on the outer side.

Fixing the enclosure beams:

Attach the Squared Timber Adapter RCS (**13**) to the Enclosure Post RCS (**1**) using eyebolts (**13.1**) and to the climbing rail with bolts (**92/94**) according to the respective hole diameter.
 Spacers (**3**) can be used.

Hole Ø 26:

Bolt ISO 4014-M24 x 130-8.8 (**94**)
 with Hex. Nut ISO 7042-M24-8 (**95**)

Hole Ø 21:

Bolt ISO 4014-M20 x 120-8.8 (**92**)
 with Hex. Nut ISO 7042-M20-8 (**93**)

Attach enclosure beam (**14**) to the Squared Timber Adapter RCS (**13**) using bolt ISO 4017:

for $h \leq 120$ mm: M12 x 140-8.8 (**2x**)

for $h > 120$ mm: M12 x 240-8.8 (**2x**)

Hex. Nut ISO 4032 M12-8 (**2x**)

Washer ISO 7093 200HV, A12 (**2x**).

(Fig. B2.13 + B2.14 + B2.15)

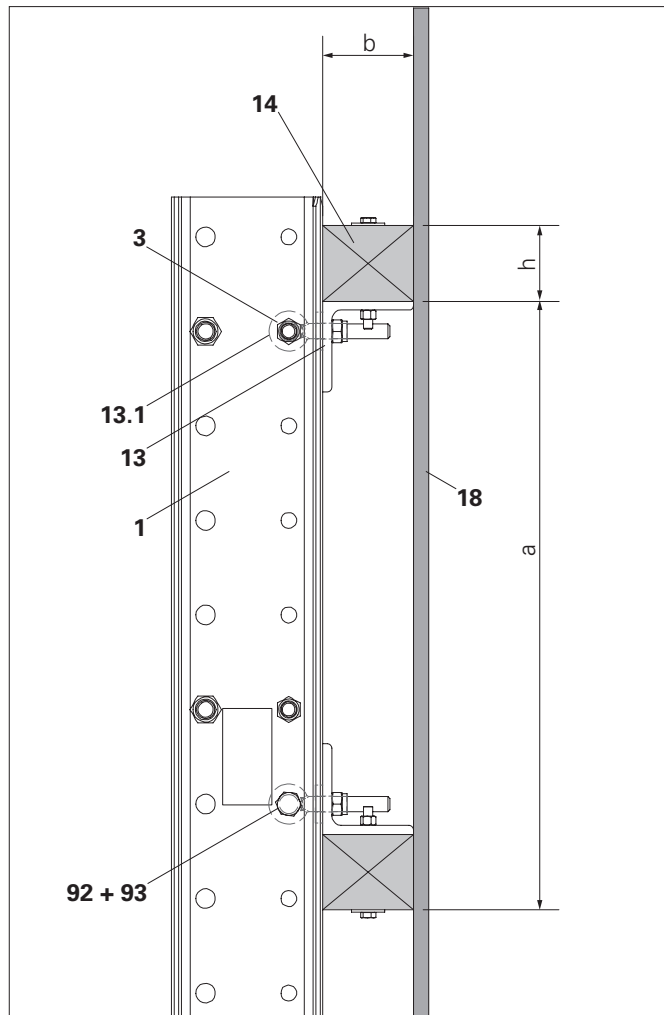

Fig. B2.13

Components

- 1** Enclosure post
- 3** Spacer M20-82
- 13** Squared Timber Adapter RCS 12/20
- 13.1** Eyebolt M20
- 14** Enclosure beam (squared timber)
- 18** Enclosure (multi-layer plywood sheeting)
- 19** Enclosure (trapezoidal metal sheeting)
- 23** Plate connector Ø 48/12 mm
- 90** Bolt ISO 4017 M12 x 140-8.8
- 91** Bolt ISO 4017 M12 x 240-8.8
- 92** Bolt ISO 4014-M20 x 120-8.8
- 93** Hex. Nut ISO 7042-M20-8
- 94** Bolt ISO 4014-M24 x 130-8.8
- 95** Hex. Nut ISO 7042-M24-8
- 96** Hex. Nut ISO 4032 M12-8
- 97** Washer ISO 7093 200HV, A12
- 98** TSS-Torx 6 x 80
- 99** TSS-Torx 6 x 60

Enclosure with multi-layer plywood sheeting

Install the enclosure (18) in accordance with the static proof.

Weight max. 15 kg/m²

Fixing by means of TSS-Torx 6x60 (99) or 6x80 (98) with given spacing e in accordance with the static proof.

(Fig. B2.14 + B2.14a)

Enclosure with trapezoidal metal sheeting

Design of enclosure (19) and its fixing (19.1) in accordance with the static proof.

Weight max. 15 kg/m²

(Fig. B2.15 + B2.15a)



The enclosure should completely enclose the working area.

Variant 1 with multi-layer plywood sheet

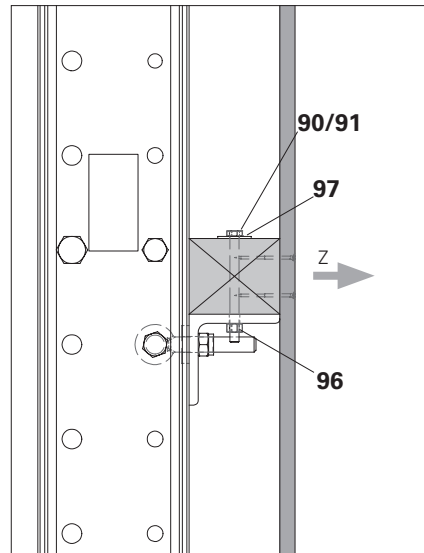

Fig. B2.14

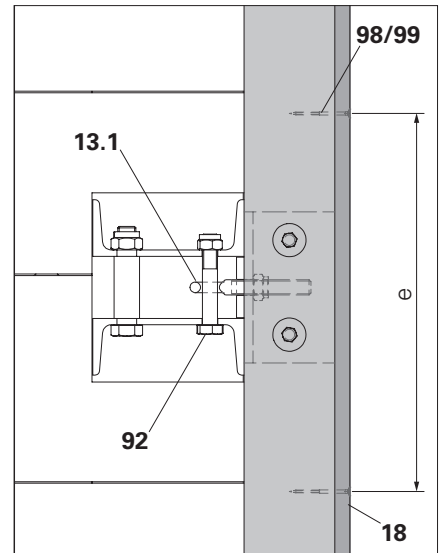

Fig. B2.14a

Fixing: Variant 1

perm. Z = 6.2 kN

(Fig. B2.14)

Fixing: Variant 2

mount an additional plate connector (23) between the enclosure beam (14) and squared timber adapter (13).

perm. Z = 9.0 kN

(Fig. B2.15)

Variant 2 with trapezoidal sheeting

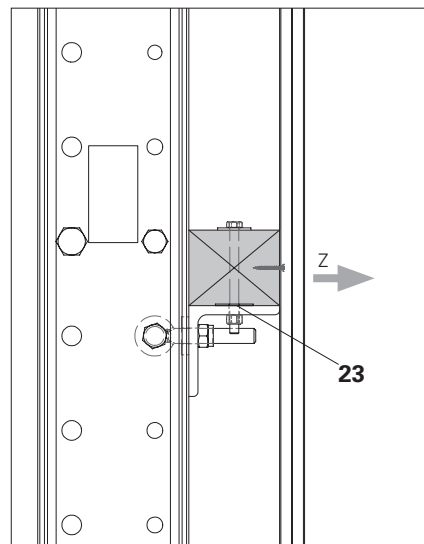

Fig. B2.15

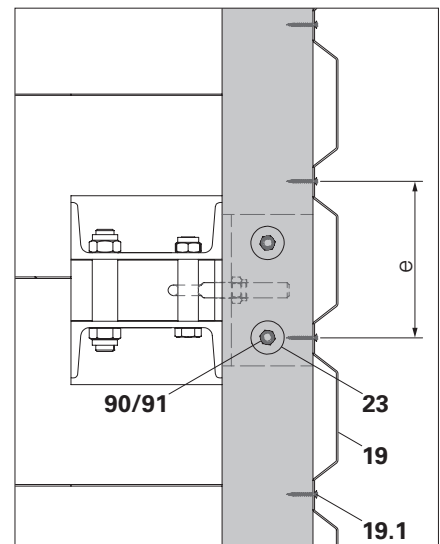

Fig. B2.15a

General

- When planning all corner solutions ensure that the enclosure on the climbing rail does not collide with the platform of the neighbouring unit during climbing.
- Maintain a distance between the climbing units of 50 mm.
- Cover gaps between the enclosure elements, e.g. with Elastomer cover tape, or foldable covers consisting of multi-layer plywood sheet. Ensure covering does not move out of position. Remove covers during the climbing procedure.
- Close all open edges with toe boards.



If there is a risk of the platforms colliding with the enclosure of the neighbouring unit during climbing, then the climbing sequence has to be specified during planning and has to be pointed out explicitly during the briefing and introduction.

For a load-optimised corner solution, arrange the slab shoes as close to the building corner as possible.



Going below a lateral edge distance c_2 for the anchoring is not advisable without additional static proof. If necessary, measure and arrange edging reinforcement in the slab.

Anchoring applicable for c_2 :

- Screw-on cone 285 mm,
- Climbing cone 320 mm.



Observe the official approvals.

Gap cover with cover tapes

Fix cover tapes to the enclosure or platform decking using Spax screws and washers.

Units straight next to each other

Fix cover tape on one side.

Units on outside corner

Fix one cover tape on each enclosure.

Units on the inside corner

Fix one cover tape on each enclosure.

Work platforms

Fix cover tape on one side.

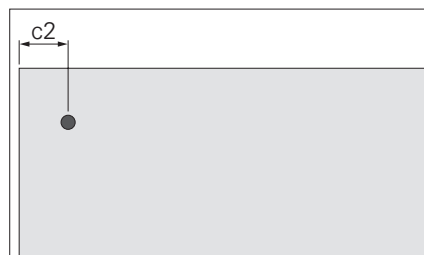

Outside corners

Mitred corner elements

Standard corner elements e.g. for internal building columns with an edge distance of $x \geq 400$ mm. (Fig. B3.02)

At the corner of the building: a cross-wise arrangement of the Slab Shoe RCS (45) and Slab Shoe Corner RCS (46). (Fig. B3.01)

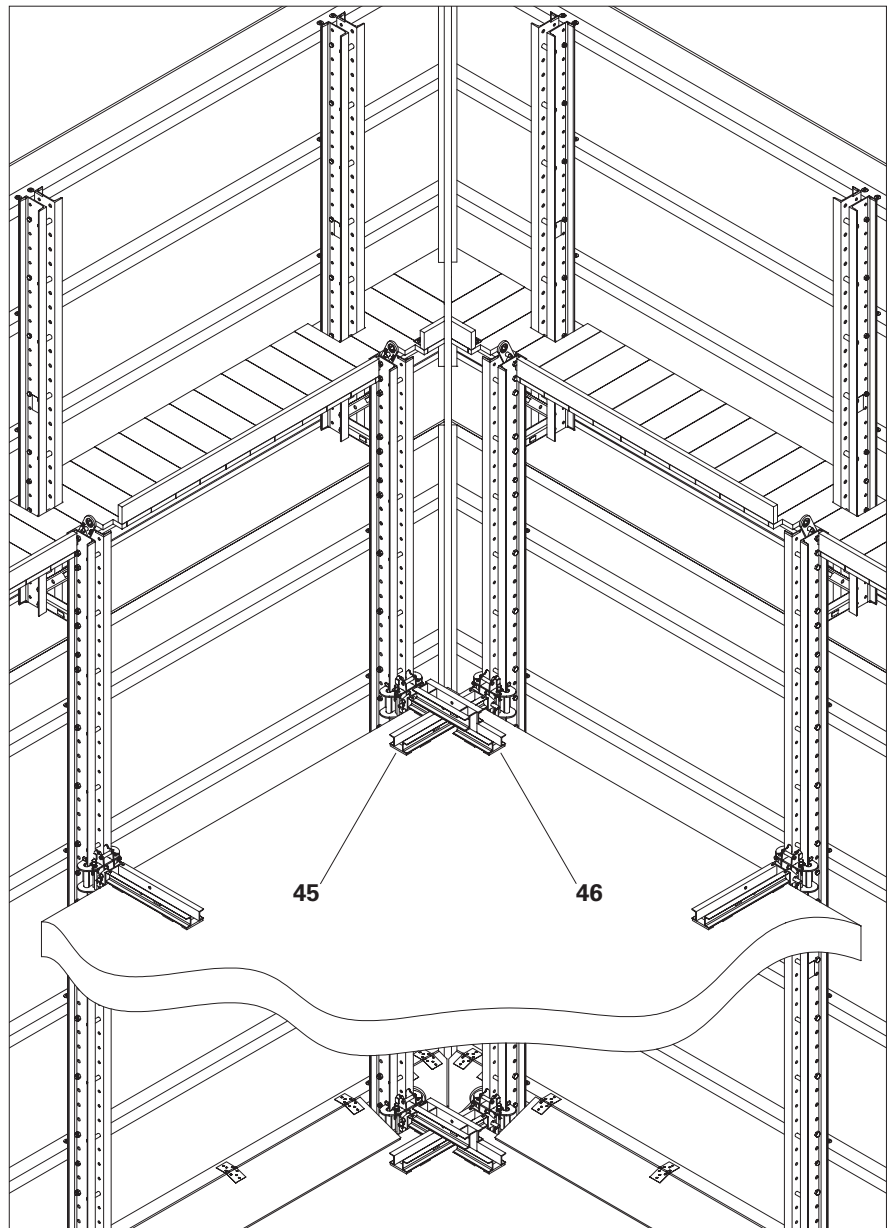

Fig. B3.01

Climbing protection panel: Variant 1
with narrow work platform, see Section A1 System overview.

The work platform is mitred accordingly. Push the enclosure beam (14) and platform beam (40) up to the mitre. Assemble platform decking using multi-layer plywood sheeting in the mitred area. Cover the mitre gap. (Fig. B3.02)

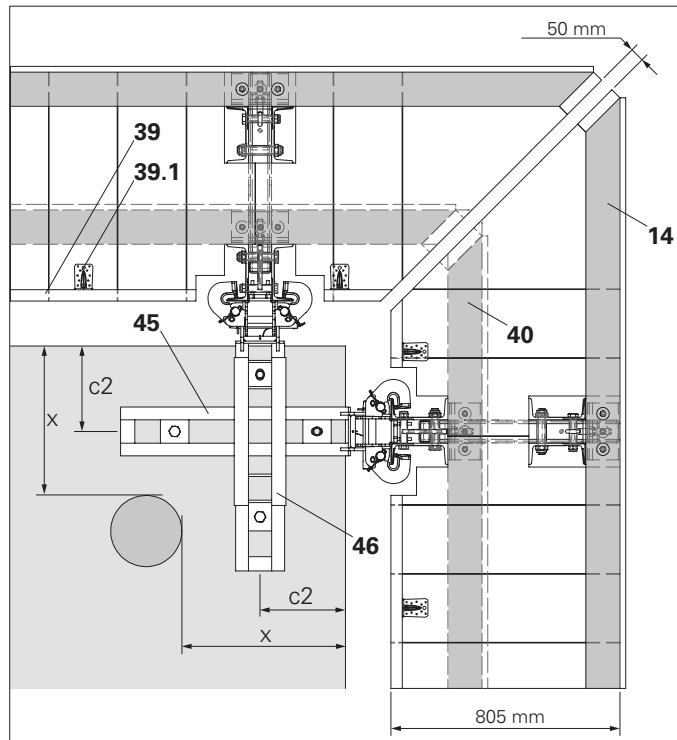

Fig. B3.02

Climbing protection panel: Variant 2 + 3
with wide work platform, see Section A1 System overview.

The work platform is mitred accordingly. Push the enclosure beam (14) and platform beam (40) up to the mitre. Assemble platform decking using multi-layer plywood sheeting in the mitred area. Cover the mitre gap. (Fig. B3.03)

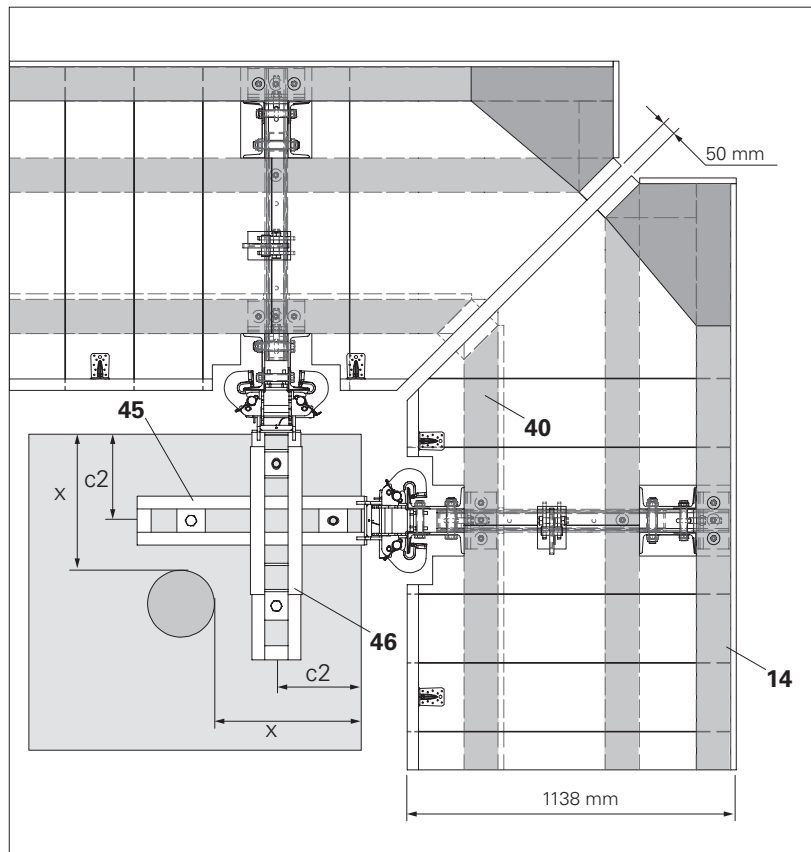

Fig. B3.03

Components

- 14** Enclosure beam (squared timber)
- 39** Toe board
- 39.1** Angle Connector 90° reinforced
- 40** Platform beam (squared timber)
- 45** Slab Shoe RCS
- 46** Slab Shoe RCS Corner

Climbing protection panel:

Variant 2 + 3

with wide work platform, see Section A1 System overview.

Provide inclined support for the work platform in the mitred area. Guide the enclosure beam (14) around the corner up to the platform joint.

Reinforce the topside and underside of the enclosure beam with multi-layer plywood sheeting (14.1).

Assemble platform decking using multi-layer plywood sheeting in the mitred area.

Cover the mitre gap.
(Fig. B3.04 + B3.05)

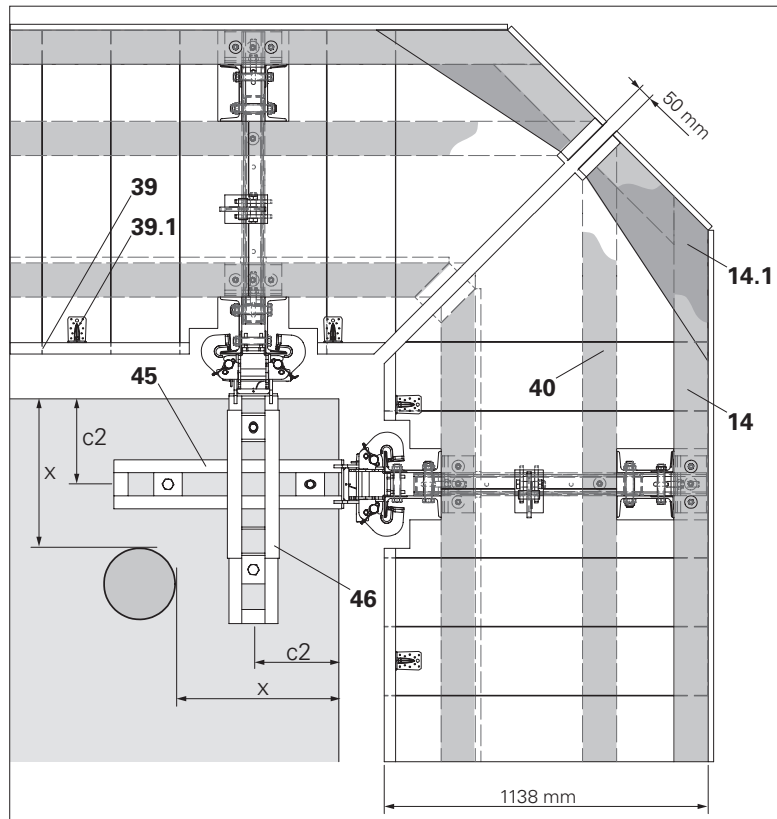

Fig. B3.04

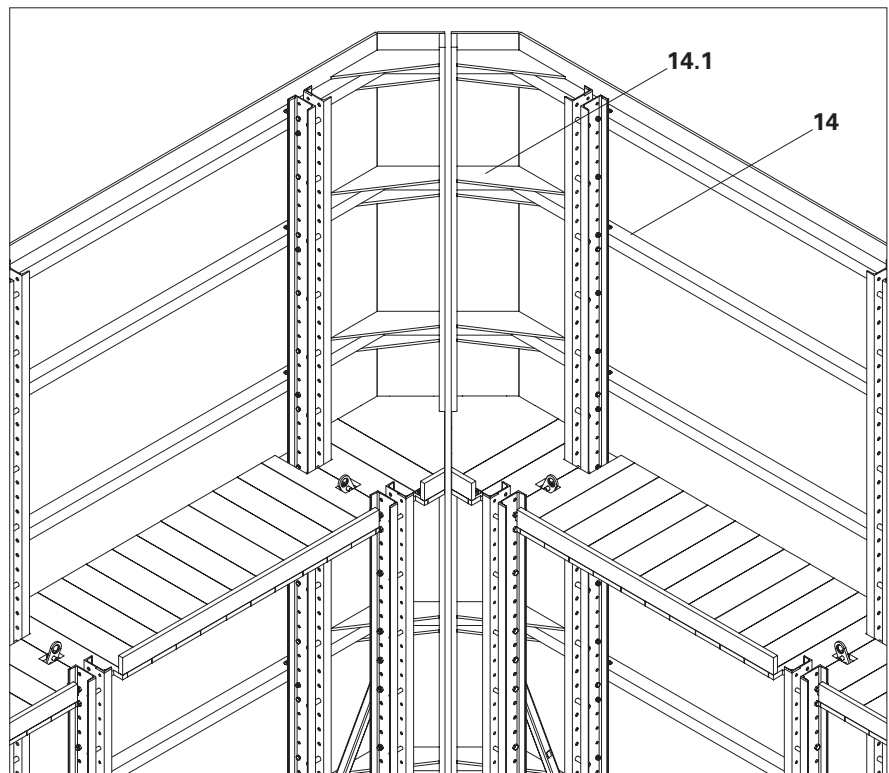

Fig. B3.05

Components

- 14** Enclosure beam (squared timber)
- 14.1** Bracing (multi-layer plywood sheeting)
- 39** Toe board
- 39.1** Angle Connector 90° reinforced
- 40** Platform beam (squared timber)
- 45** Slab Shoe RCS
- 46** Slab Shoe RCS Corner

Corner supports at the edge of the building

For corner support, mount the Stop End Slab Shoe RCS (**48**).

The work platform in the mitred area is implemented as previously described.

The corresponding stop end slab tie (**51/52**) enables anchoring through the prop reinforcement.

Due to load transfer through the bond, the stop end slab tie can be positioned very close to the slab edge. (Fig. B3.06) See Section B4 "Anchoring on the slab front side"



Going below a lateral edge distance c_1 for the anchoring is not advisable without additional static proof. If necessary, measure and arrange edging reinforcement in the slab.

Anchoring applicable for c_2 : screw-on cone 285 mm, climbing cone 320 mm. (Fig. B3.06)

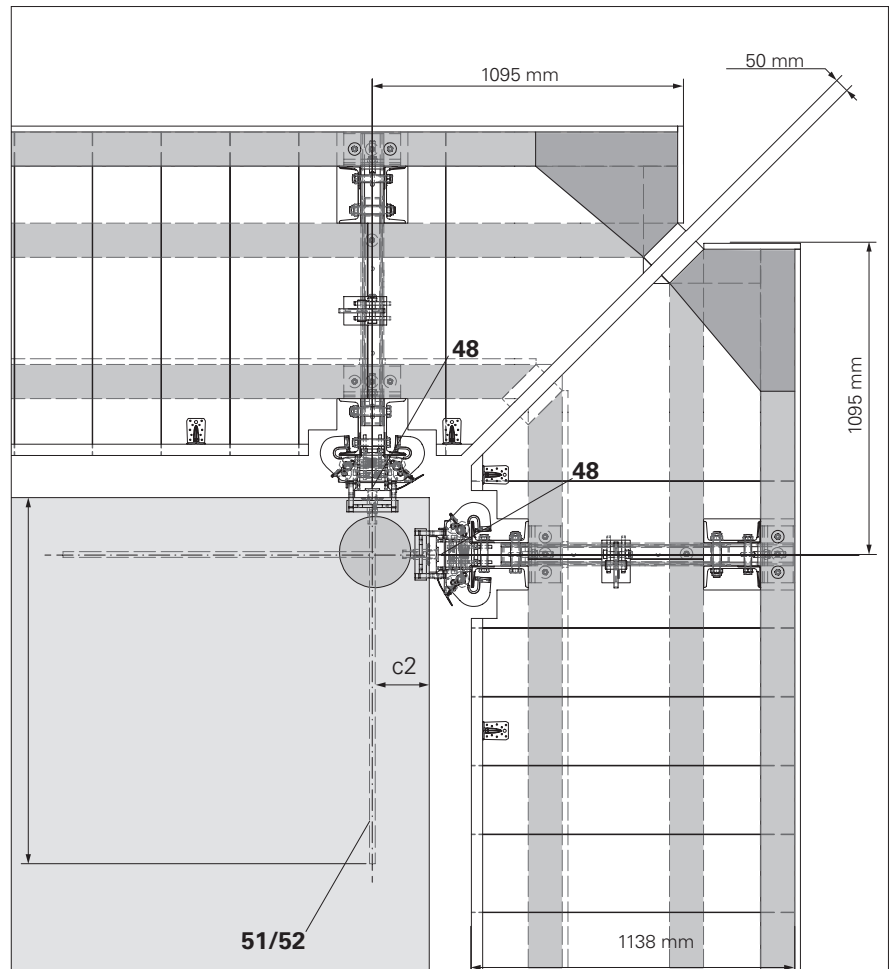

Fig. B3.06

Components

- 48** Stop End Slab Shoe RCS
- 51** Stop End Slab Tie M30/25-160
- 52** Stop End Slab Tie M24/20-128

Overlapping corner elements

With large building columns in the corner of a building, the corner elements can also be overlapped.

In order to keep the cantilever of the corner element to a minimum, a Wall Shoe RCS (**59**) can be used for anchoring in the prop. See Section B4 "Anchoring on props and walls".

The side wind load on corner platforms is kept to a minimum through an open, multi-part design of the lateral guard-rails (**85**).

PERI recommends scaffolding tube bracing.

An enclosure consisting of netting or sheeting which is attached to this must be removed if wind speeds of over 100 km/h are expected.

For transferring force under the Lbracket (**86**), screw on planks (**37a**) transversely to the direction of the decking (**37**). Fix lateral planking to planking as well as the planking on platform beams (**40**) by means of Torx screws (**99**).

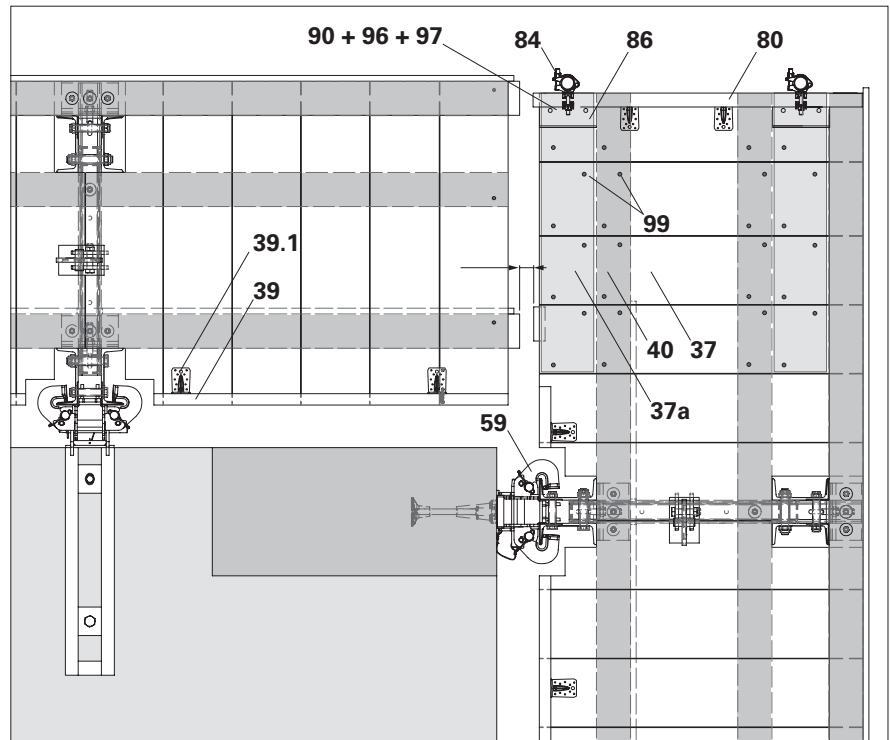

Fig. B3.07

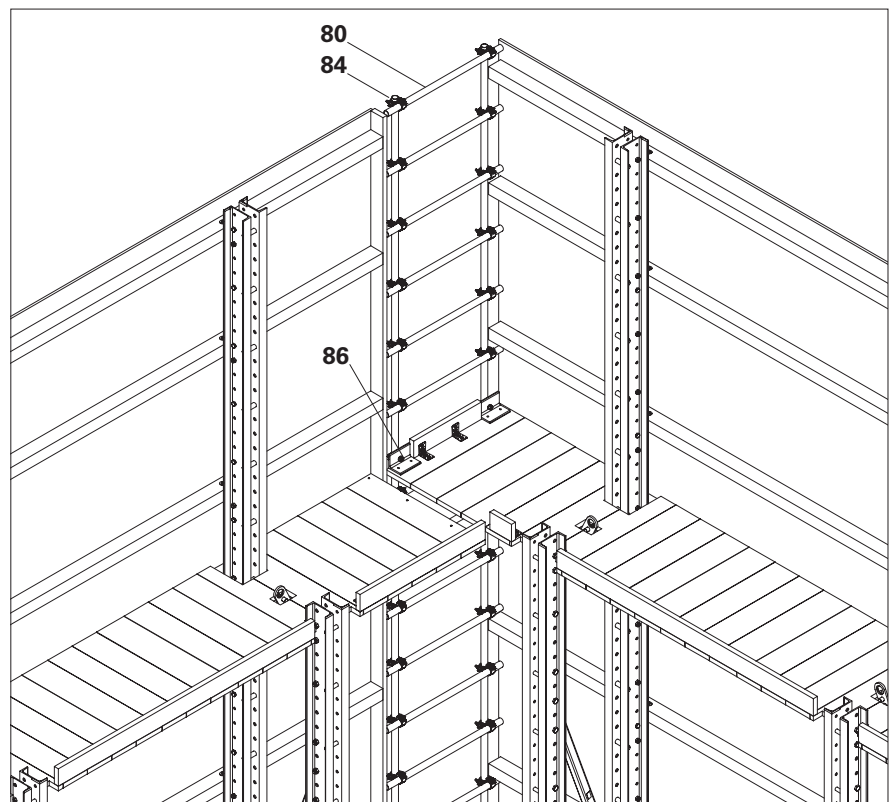

Fig. B3.08

Components

- 37** Work platform decking (planks)
- 39** Toe board
- 39.1** Squared timber angle connector 90°
- 40** Platform beam (squared timber)
- 59** Wall Shoe RCS
- 80** Steel scaffolding tube Ø 48.3 x 3.2
- 84** Standard Coupler NK 48/48
- 85** Guardrail
- 86** Lbracket RCS
- 90** Bolt ISO 4017 M12 x 140-8.8
- 96** Nut ISO 4032 M12-8
- 97** Washer ISO 7093 200HV, A12
- 99** TSS-Torx 6 x 60

Bracing of corner elements

In the case of expected wind speeds of more than 100 km/h, corner elements are to be additionally secured with temporary diagonal bracing.

Angle of inclination $\alpha = 45 \pm 5^\circ$

Anchoring with
4 x heavy-duty dowel $\varnothing 22$ (117),
Dowel spacings 130 x 230 mm,
e.g. Hilti HDA-T M12

Alternative
2 x heavy-duty dowel $\varnothing 30$ (118),
Dowel spacing 230 mm,
e.g. Hilti HDA-T M16.

Components

- 47.6** Tie Rod DW 15, special length
- 79** Fitting pin $\varnothing 26$ mm
- 117** Heavy-duty dowel $\varnothing 22$
- 118** Heavy-duty dowel $\varnothing 30$
- 119** Hex. Nut DW 15 AF 30/50
- 121** Spindle Shoe SLS/RCS M24
- 122** Bracing Shoe RCS DW 15
- 123** Eye Nut RCS DW 15
- 125** Articulated Spanner RCS DW 15

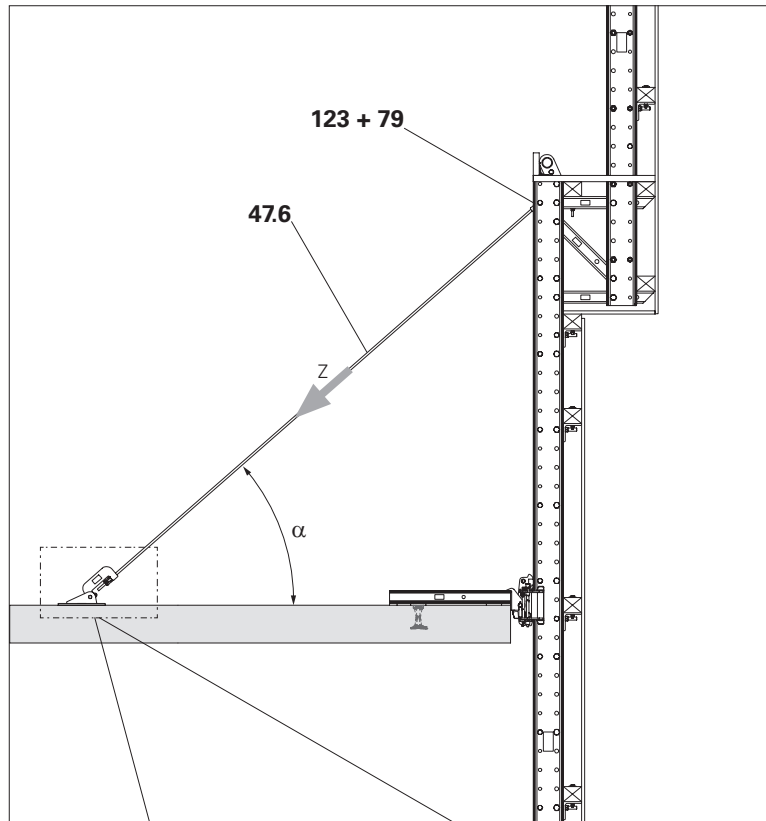

Fig. B3.08



The heavy-duty dowels used have to be statically verified for the oblique tension force Z.

The given minimum slab thicknesses and edge distances are valid for the mentioned dowels only.

Take into consideration the technical documentation of the dowel that has been used!

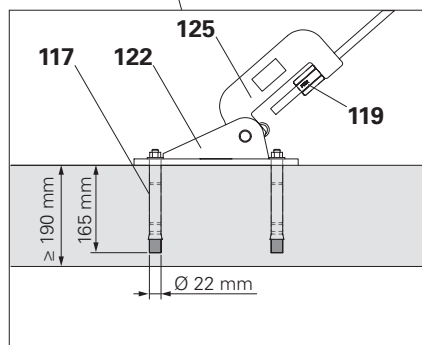

Fig. B3.08a

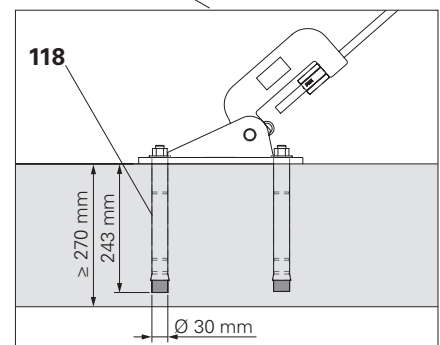

Fig. B3.08c

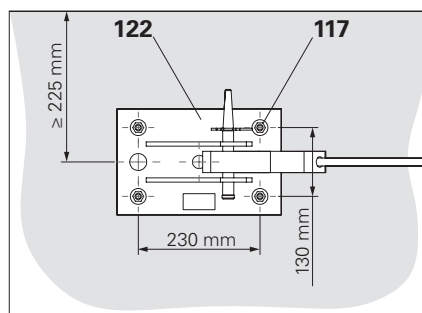

Fig. B3.08b

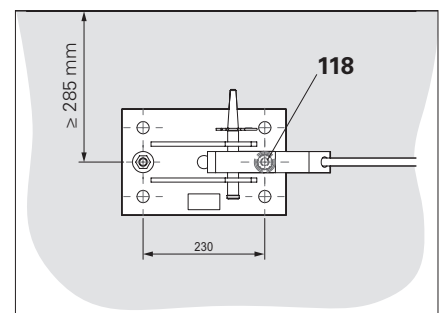

Fig. B3.08d

Inside corners

For inside corners, PERI recommends having a mitred arrangement.

The work platform is mitred accordingly. Push the enclosure beam (14) and platform beam (40) up to the mitre. Assemble platform decking using multi-layer plywood sheeting in the mitred area. Cover the mitre gap. (Fig. B3.09)

Components

- | | |
|-------------|---------------------------------|
| 14 | Enclosure beam (squared timber) |
| 39 | Toe board |
| 39.1 | Angle Connector 90° reinforced |
| 40 | Platform beam (squared timber) |

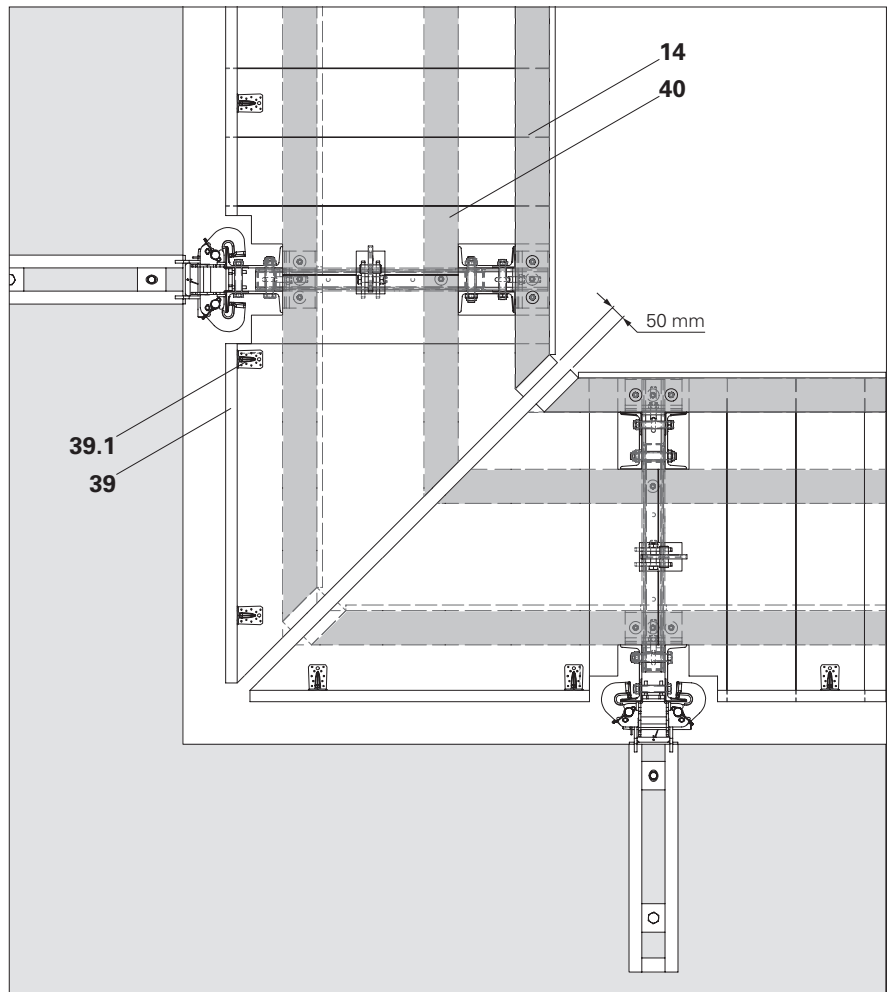

Fig. B3.09

Non-rectangular building corners

A combination of the Slab Shoe RCS (45) with the Slab Shoe Corner RCS (46) in the corner.

Using the Slab Shoe Corner RCS on non-rectangular corners results in an application range of min. 65° and max. 115°.

The tie arrangement is determined by the edge distance in the direction of force of 600 mm and through the intersecting point distance of the slab shoe axes to the slab edge of 300 mm.



Going below a lateral edge distance c_1 for the anchoring is not advisable without additional static proof. If necessary, measure and arrange edging reinforcement in the slab.

Anchoring applicable for c_1 : screw-on cone 285 mm, climbing cone 320 mm. (Fig. B3.10)

Obtuse-angled corners

The work platform is mitred accordingly. Push the enclosure beam (14) and platform beam (40) up to the mitre.

Assemble platform decking using multi-layer plywood sheeting in the mitred area.

Cover the mitre gap.

(Fig. B3.10)

Components

- | | |
|----|---------------------------------|
| 14 | Enclosure beam (squared timber) |
| 40 | Platform beam (squared timber) |
| 45 | Slab Shoe RCS |
| 46 | Slab Shoe RCS Corner |

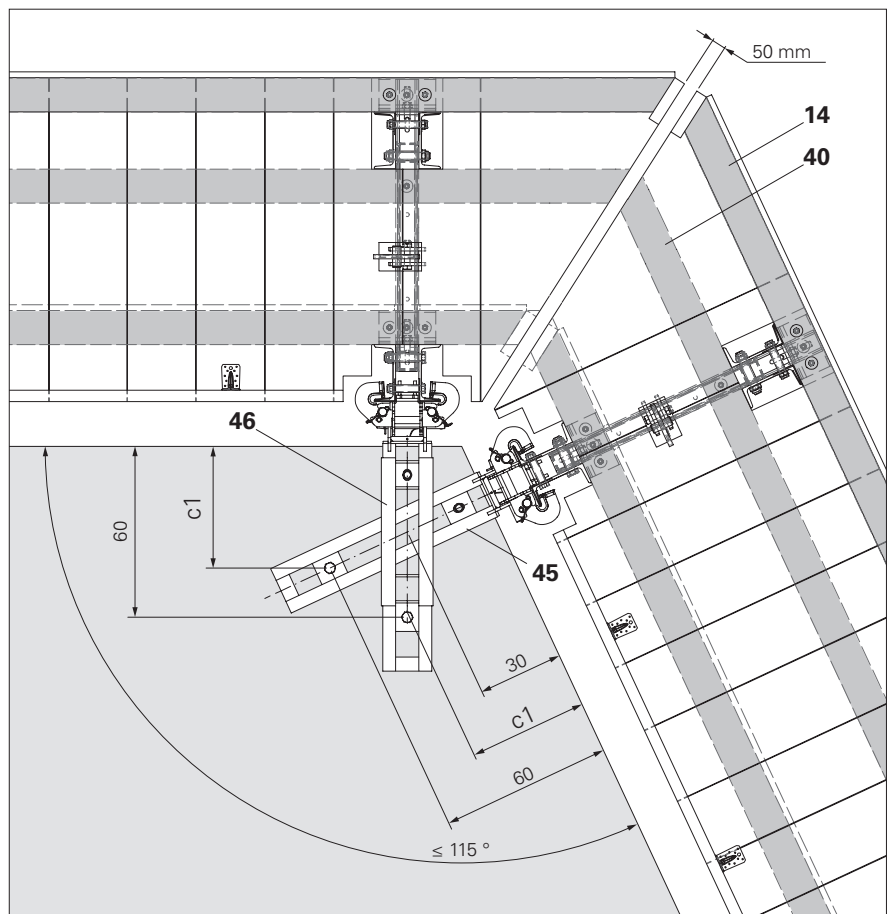

Fig. B3.10

Acute-angled corners

Provide inclined support for the work platform in the mitred area. Guide the enclosure beam (14) around the corner up to the platform joint.

Reinforce the topside and underside of the enclosure beam with multi-layer plywood sheeting (14.1).

Assemble platform decking using multi-layer plywood sheeting in the mitred area.

Cover the mitre gap.
(Fig. B3.11)



Depending on the assumed wind load, additional transverse bracing may be required.

Components

- 14** Enclosure beam (squared timber)
- 14.1** Multi-layer plywood sheet
- 40** Platform beam (squared timber)
- 45** Slab Shoe RCS
- 46** Slab Shoe RCS Corner

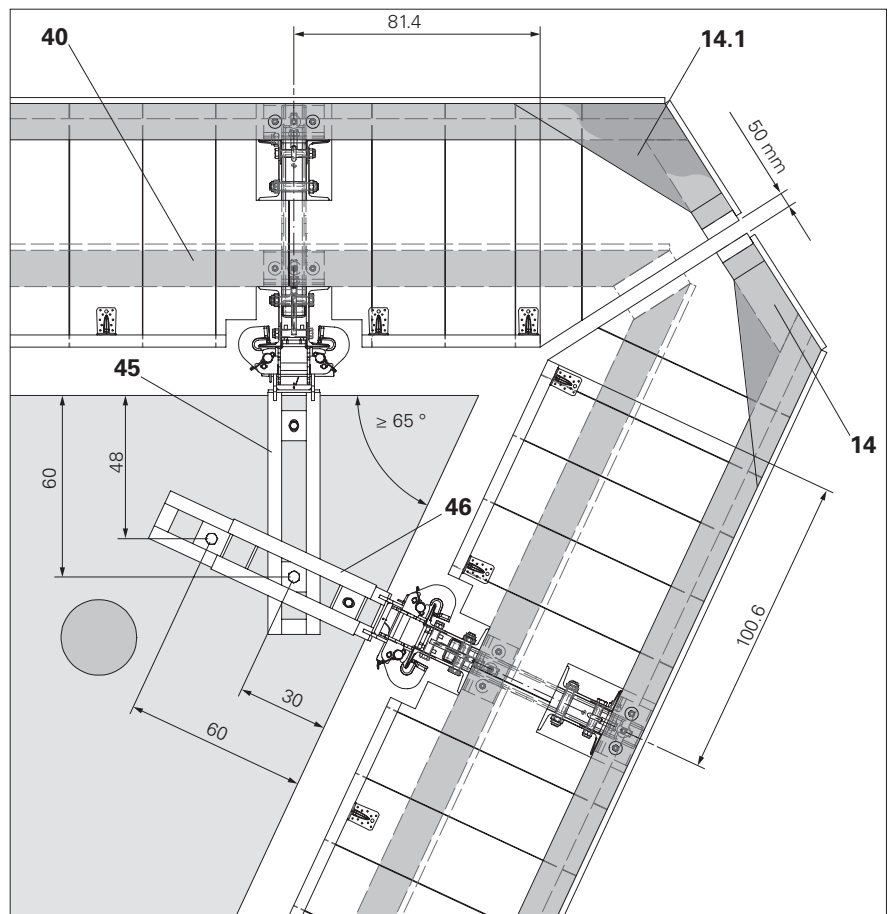

Fig. B3.11

Units on circular structures

On circular structures, the work platforms are generally jointed with a mitre cut.

Slab shoes (45), climbing rails (2) and crossbars (10) are arranged parallel to each other for each climbing unit.

Plan the anchoring of the slab shoes to be at least 20 cm apart. Otherwise static proof is to be provided.

The smallest possible building radius is to be shown on the drawing. During the planning process, take into consideration a gap s of ≥ 30 mm between the work platform decking (36) and edge of the building.

The foldable covers (41) must be wide enough to cover all areas of the building edge.

The position of the anchoring is to be determined on the drawing and must be clearly dimensioned.

Ensure that gap covers cannot move out of position.



The lateral adjustability of the slab shoe (45) must be guaranteed. Therefore, during the planning phase, ensure that the gap x between the building edge and the stop plate of the slab shoe is a min. of 10 mm along the whole width of the shoe.

This is ensured if the Slab Tie Gauge 61 RCS is used. (Fig. B4.01a + B4.01b)

Components

- 10 Crossbar RCS 103
- 14 Enclosure beam (squared timber)
- 36 Work platform decking
- 45 Slab Shoe RCS

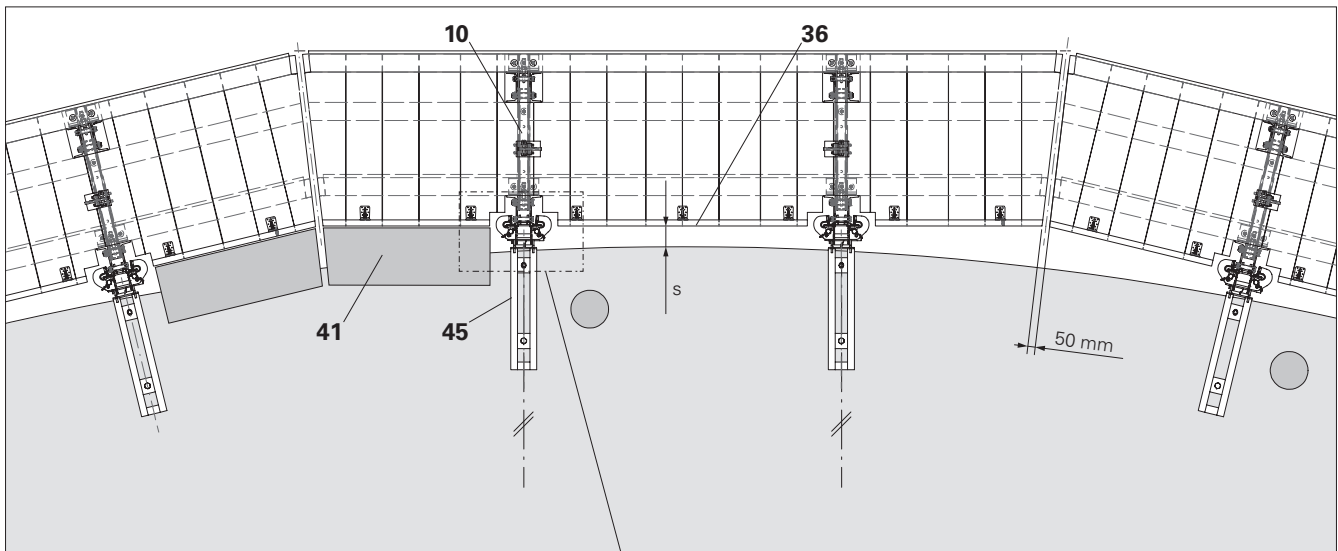

Fig. B4.01

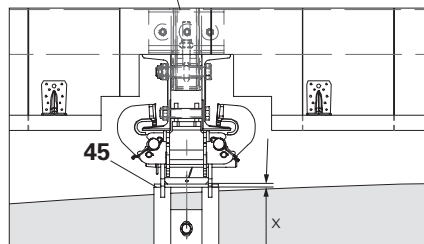

Fig. B4.01a

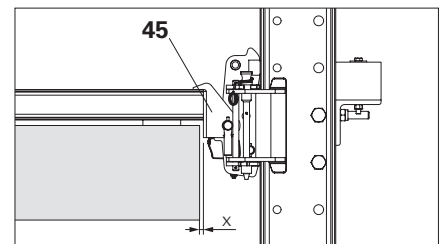

Fig. B4.01b

Anchoring to props or walls

Suspension with Wall Shoe RCS

The climbing shoe (44) is bolted by means of a locking pin (59.1) to the Wall Shoe RCS (59).

Slab shoes and wall shoes must be in the same vertical system grid. For this, the suspension of the wall shoe (59) is height-adjusted by Δh in 125 mm increments to the upper edge of the slab. (Fig. B4.02 + B4.02b)

If the climbing enclosure is to be moved with the self-climbing device, an offset Δh of 500 mm is required.

Anchoring for the wall shoe:

- Threaded Anchor Plate DW20 (47.2)
- Tie Rod DW20 L = t – 77 mm (47.10)
- Climbing Cone M30/DW 20 (47.9)

Fix the Wall Shoe RCS (59) to the anchoring (47) using a hex. bolt ISO 4014 M30x70-8.8.

Adapt foldable covers to suit the building columns.
Close remaining gaps with cover mat and cover tape.



- Determine the required anchoring depth and concrete strength according to separate static calculations in accordance with Building Authority Approval Z-21.6-1767.
- Separate static proof is required and the support forces must be determined separately!
- The negative offset of the wall shoe is to be added to the storey height itself and taken into account in the structural design.

Components

44	Climbing Shoe RCS
47.2	Threaded Anchor Plate DW 20
47.9	Climbing Cone M30/DW 20
47.10	Tie Rod DW20, special length
49	Bolt ISO 4017 M30 x 70-8.8
59	Wall Shoe RCS

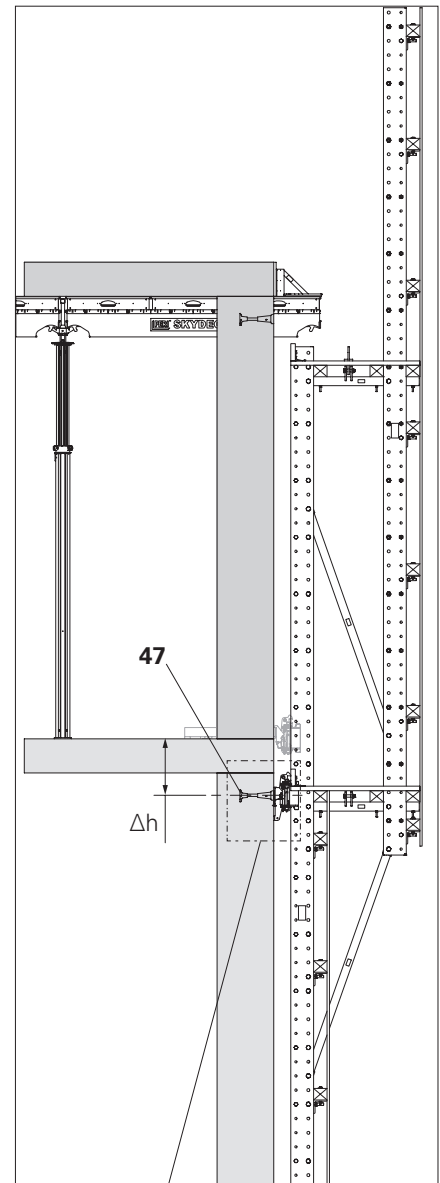

Fig. B4.02

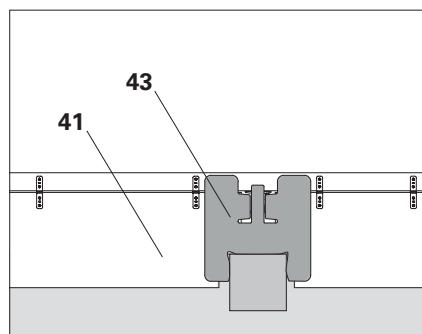

Fig. B4.02a

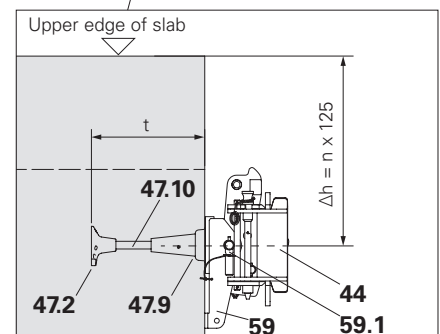

Fig. B4.02b

Anchoring on the front side of the slab

Suspension with the Stop End Slab Shoe RCS

The Stop End Slab Shoe RCS transfers vertical forces into the slab edge through contact. As a result, the anchoring is loaded with tension forces only.

Due to the slot in the Stop End Slab Shoe RCS, two stop end slab ties can be installed crosswise and vertically offset at the corners of the building.

The Stop End Slab Shoe RCS (48) is fixed according to the anchoring type with corresponding bolts M30x70 (49) or bolt M24x70 (53) and reducing bushing Ø30-25 (50) to the Stop End Slab Tie M30/25-160 (51) or M24/20-128 (52).

(Fig. B4.03)

The mounting height is offset by 125 mm to the upper edge of the slab (mounting height of the standard slab shoe).

If the climbing unit is to be moved with the climbing device, the mounting height must not change for each element. To ensure that all panels hang at the same height, fit additional spacers in the climbing rail.



Observe the type test.

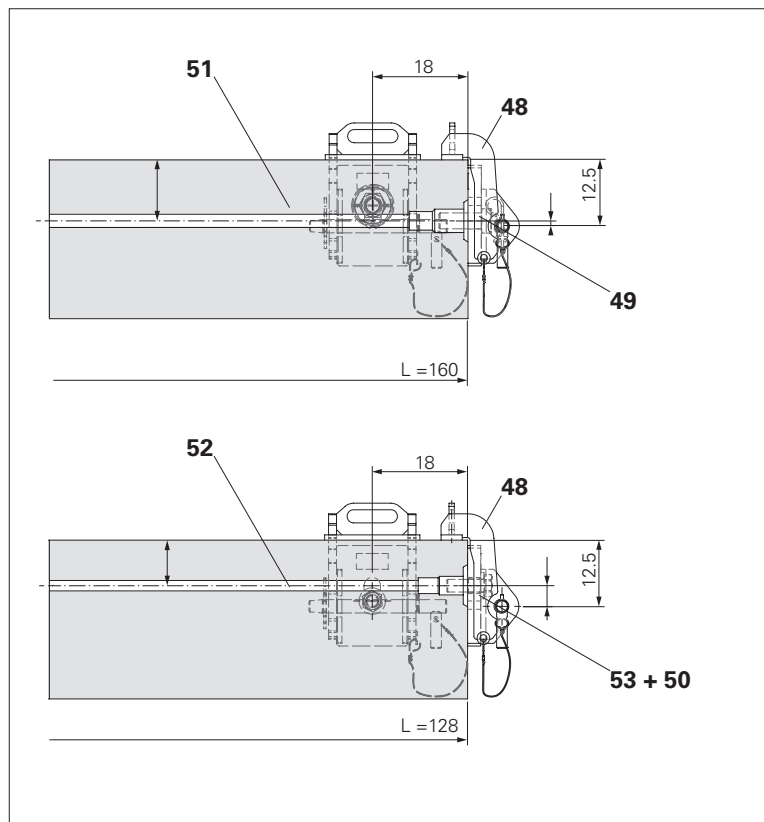

Fig. B4.03

Components

- 48 Stop End Slab Shoe RCS
- 49 Bolt ISO 4017 M30 x 70-8.8
- 50 Reducing bushing Ø 30 - 25
- 51 Stop End Slab Tie M30/25-160
- 52 Stop End Slab Tie M24/20-128
- 53 Bolt ISO 4014 M24 x 70-10.9
- 89 Slab prop



Determine the required anchoring depth, additional reinforcement, support and concrete strength according to separate static calculations.



Warning

Falling fasteners (49, 50, 53) may strike people!

This can result in serious injuries.

- ⇒ Attach a trailing catching box (87) to the climbing unit. (Fig. B4.04)
- ⇒ Cordon off danger zones.
- ⇒ Danger zones to be protected by safety roofs.

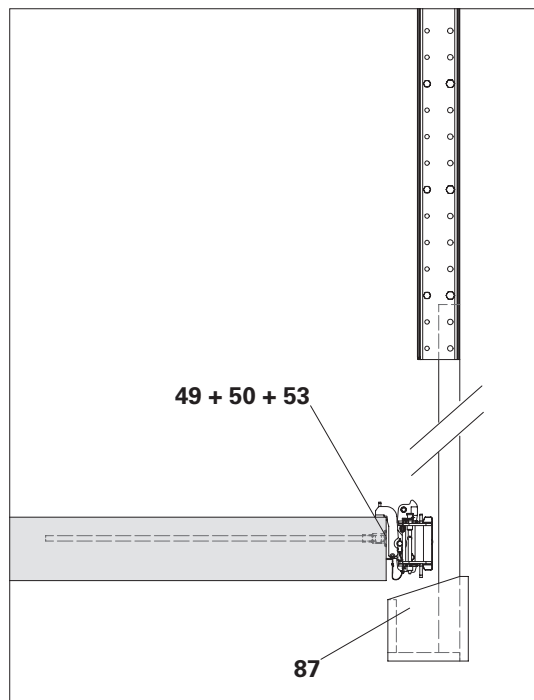

Fig. B4.04

If the stirrup reinforcement (B) at the slab edge is located behind the axis (A) of the load transfer point (max. 30 mm), then the slab edge has to be supported separately.

PERI recommends that an approx. 10 mm steel plate (89.1) be securely fixed to a slab prop (89) and positioned at the slab edge.

Hole diameter in the plate 13 mm, hole arrangement depends on the type of slab prop used. Countersink plate approx. 7 mm deep at 90°. Use Ø 14 mm holes in the prop head. Provide at least 2 screw connections.

Screw connection: countersunk screw M12x35 8.8, with nut. (Fig. B4.05)

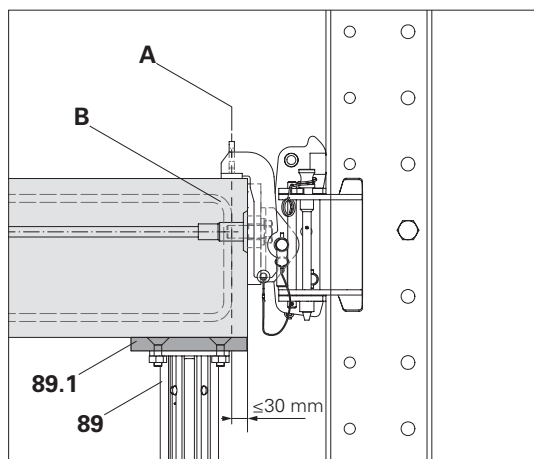

Fig. B4.05



The safe transfer of the loads into the reinforced concrete slab and further transfer have to be verified separately by a structural analysis.

General

For pre-assembly, there must be a sufficiently large and level assembly area available, as well as sufficient space for temporary storage.

A crane or other lifting equipment is required.

Intermediate states must be secured by means of temporary supports to prevent any tipping over.

Assembly is carried out on aligned squared timbers.

Preparing the climbing rails

Position Climbing Rails RCS on squared timbers. Observe centre of gravity position with enclosure post.



Note

Risk of collision!

⇒ Only use the specified bolt lengths and nuts.

Fitting the spacer M20

In some cases, the additional installation of a spacer M20-82 (**3**) may be required as a climbing bolt in the climbing rail, see "Additional Spacers" on Page 32.

Components

- 3** Spacer M20-82
 - 3.1** Spacer tube $\text{Ø}26.9 \times 2.6 \dots 82$
 - 3.2** Bolt ISO 4014 M20 x 120-8.8
 - 3.3** Nut ISO 7042 M20-8
-

Assembly

1. Position spacer tube $\text{\O}26$ (**3.1**) of the spacer M20 (**3**) in the Climbing Rail RCS with the help of a hammer.
2. Insert bolt M20 \times 120 (**3.2**) through the holes $\text{\O}21$ of the climbing rail and through the spacer tube.
3. Attach self-locking nut M20-8 (**3.3**) (AF30) to the bolt and tighten. Tightening torque min. 100 Nm. (Fig. C1.01)



- Spacers M20 (climbing bolts) must not be moved within the climbing rail, but installed in addition. The stroke of the climbing device allows a maximum distance of 50 cm from the spacers.
- It may be necessary to release adjacent spacers in the climbing rail. After mounting the additional spacer, re-tighten all previously loosened bolts. Tightening torque min. 60 Nm.



Has the nut (**3.3**) been tightened?

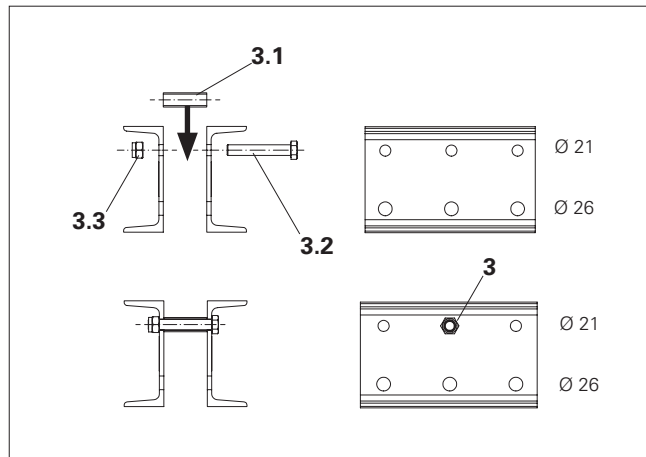

Fig. C1.01

Re-positioning spacer M24

In some cases, re-positioning of spacers M24 in the climbing rail or enclosure post is required

Components

- 4** Spacer M24-82
- 4.1** Spacer tube $\text{Ø}33.7 \times 4 \dots 82$
- 4.2** Bolt ISO 4014 M24 x 130-8.8
- 4.3** Nut ISO 7042 M24-8

Assembly

1. Remove nut M24-8 (**4.3**) (AF36).
2. Remove bolt M24x130 (**4.2**).
3. Re-position spacer tube $\text{Ø}33.7$ (**4.1**) of the spacer M24 with the help of a hammer.
4. Insert bolt M24x130 (**4.2**) through the holes $\text{Ø}26$ of the climbing rail and through the spacer tube.
5. Attach self-locking nut M24-8 (AF36) to the bolt and tighten. Tightening torque min. 150 Nm.

(Fig. C1.02)

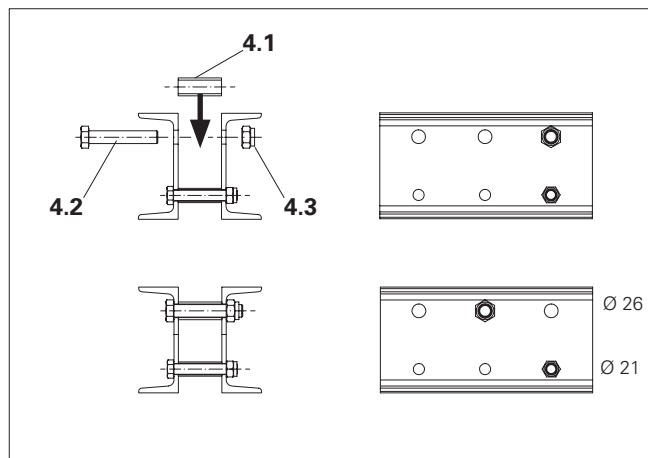

Fig. C1.02



It may be necessary to release adjacent spacers in the climbing rail. After mounting the additional spacer, re-tighten all previously loosened bolts. Tightening torque min. 150 Nm.

Assembly of the attachment points

Variant 1 with Crossbar RCS 69:

The Lifting Eye BR-2 2.5 t (7) is fixed to the Climbing Rail RCS (2) with the spacer M24 (4).

Components

- 4** Spacer M24-82
- 4.1** Spacer tube $\text{Ø}33.7 \times 4 \dots 82$
- 4.2** Bolt ISO 4014 M24 x 130-8.8
- 4.3** Nut ISO 7042 M24-8
- 8** Lifting Eye BR-2 2.5 t

Assembly

1. Position spacer tube $\text{Ø}33.7$ (4.1) of the spacer M24 together with Lifting Eye BR 2.5 t (8) on the top-most hole $\text{Ø}26$ of the climbing rail (2) with the help of a hammer.
2. Insert bolt M24x130 (4.2) through the holes $\text{Ø}26$ of the climbing rail and through the spacer tube.
3. Attach self-locking nut M24-8 (4.3) (AF36) to the bolt and tighten.



Has the nut been tightened?



- Permissible load per Lifting Eye BR-2 2.5 t: max. 25 kN.
- For moving heavy climbing units, use climbing beam 9 t. Use a spacer as an attachment point.
- Observe the relevant Instructions for Use!

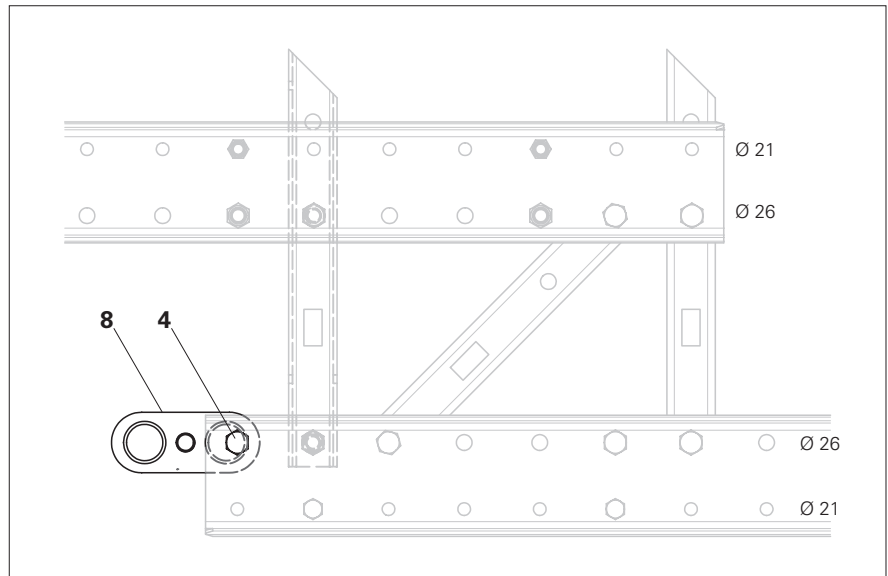

Fig. C1.03

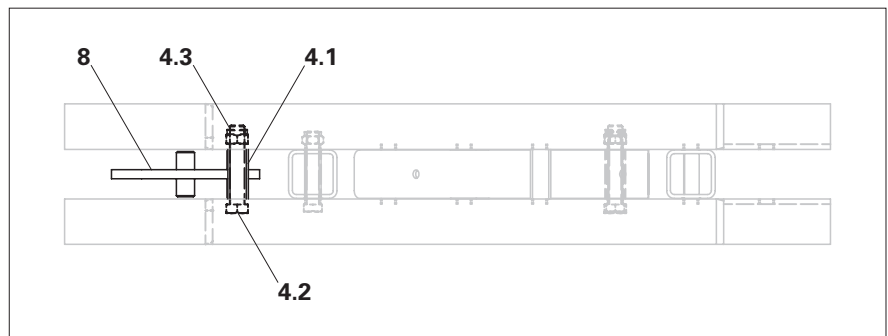

Fig. C1.03a

Variant 2 and 3 with Crossbar RCS 103:

Attach the Lifting Eye BR-2 2.5 t to the Crossbar 103 RCS.

Components

- 8** Lifting Eye BR-2 2.5 t
- 10** Crossbar RCS 103
- 10.1** Hex. Screw ISO 4014 M20x90-8.8
- 10.2** Nut ISO 4032 M20-8
- 10.3** Bracket

Assembly

1. Attach Lifting Eye BR-2 2.5 t (**8**) with the provided bolts M20x90-8.8 (**94**) and nuts M20-8 (**95**) to the brackets (**10.3**) of the Crossbar RCS 103 (**10**).



Has the nut been tightened?



- Permissible load per Lifting Eye BR-2 2.5 t: max. 25 kN.
- For moving heavy climbing units, use climbing beam 9 t.
- Observe the relevant Instructions for Use.

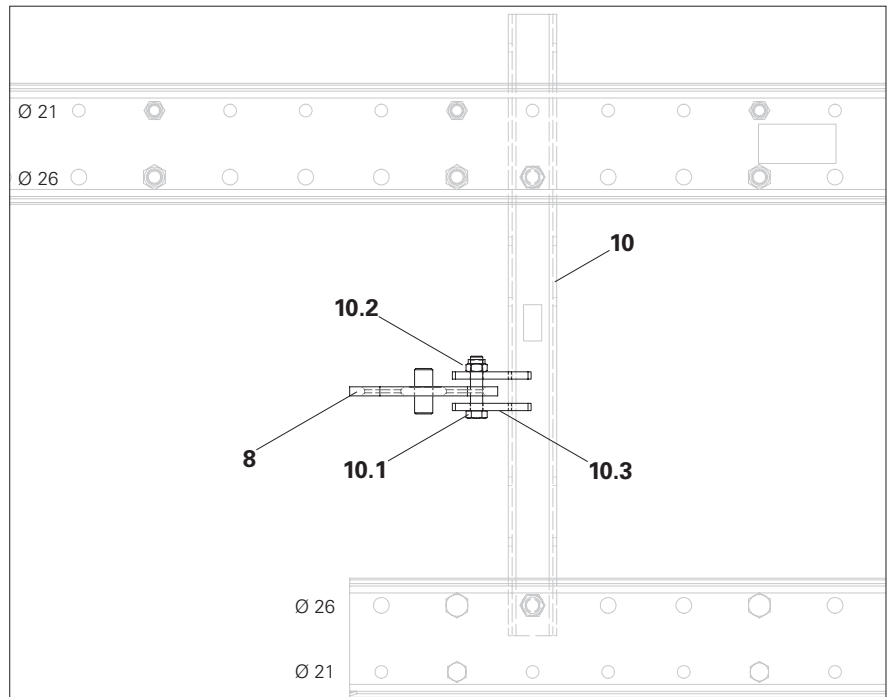

Fig. C1.04

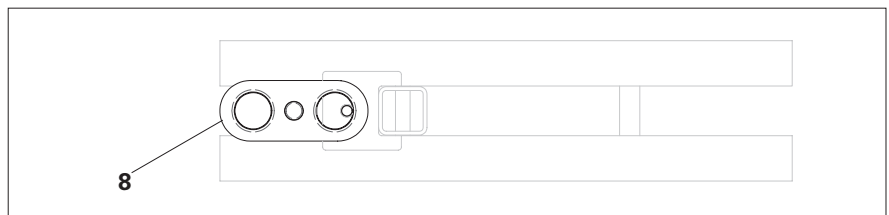

Fig. C1.04a

Assembly of Climbing Rail Connector RCS 73

Enclosure post variant 3:

The Climbing Rail RCS 748 (**1.2**) is extended with a Climbing Rail RCS 148 (**1.4**) or 248 (**1.3**). For connecting the climbing rails, mount a Climbing Rail RCS 73 (**17**).

Components

- 1.2** Climbing Rail RCS 748
- 1.3** Climbing Rail RCS 248
- 1.4** Climbing Rail RCS 148
- 17** Climbing Rail Connector RCS 73
- 24** Fitting pin $\varnothing 21 \times 120$
- 26** Cotter pin 4/1

Assembly

1. Remove or re-position spacers in the climbing rail that are in the way. See "Preparing the climbing rails" on page 66.
2. Insert climbing rail connector (**17**) into the Climbing Rail RCS 748 (**1.2**) and connect with 2 fitting pins $\varnothing 21$ (**24**) in holes $\varnothing 21$.
3. Insert short Climbing Rail RCS (**1.3/1.4**) into the climbing rail connector and connect with 2 fitting pins $\varnothing 21$ in holes $\varnothing 21$.
4. Secure all fitting pins with cotter pins (**26**).

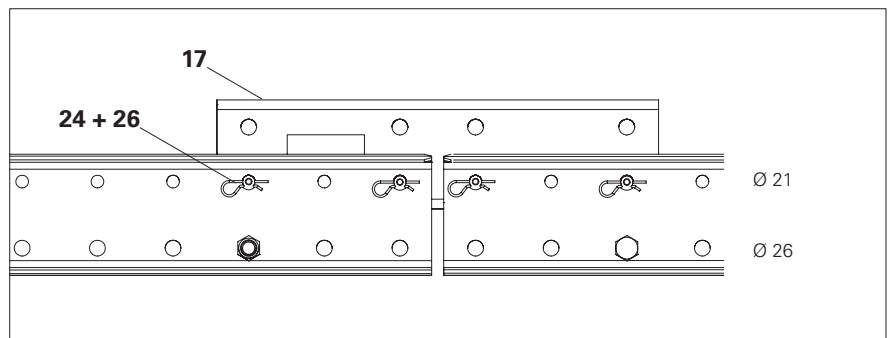

Fig. C1.05

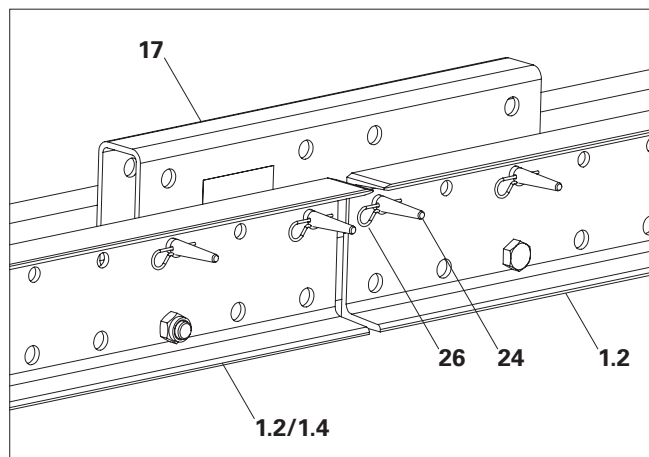

Fig. C1.05a

Assembly of the bracket framework



- Assembly is explained using Variant 2. The assembly of the other variants is analogous.
- The respective dimensions for the assembly are specified in the site-specific assembly drawings.

Installing climbing rails

Components

- | | |
|-----------|----------------------------------|
| 2 | Climbing Rail RCS |
| 13 | Squared Timber Adapter RCS 12/20 |
| 14 | Enclosure beam (squared timber) |

Assembly

1. Prepare two climbing rails (**2**), with spacers \varnothing 26 mm above on squared timbers and align them according to the planned dimensions between axes.
2. Mount several enclosure beams (**14**) with squared timber adapters (**13**) according to plan. See Section "C3 Assembly of the enclosure" on page 84.
 - The axial dimension of the climbing rails is fixed.
 - The enclosure beam also acts simultaneously as anti-tilt protection for bracket units.

(Fig. C1.06 + C1.06a)

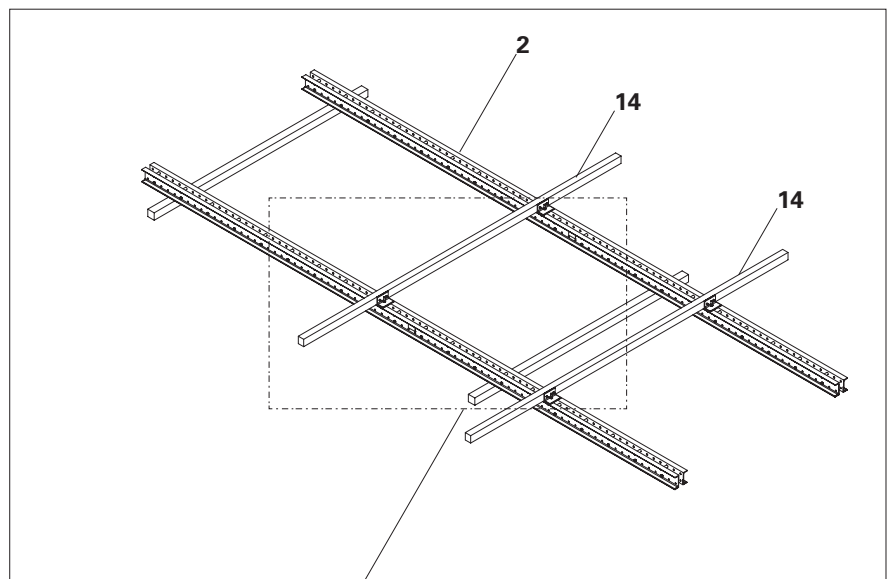

Fig. C1.06

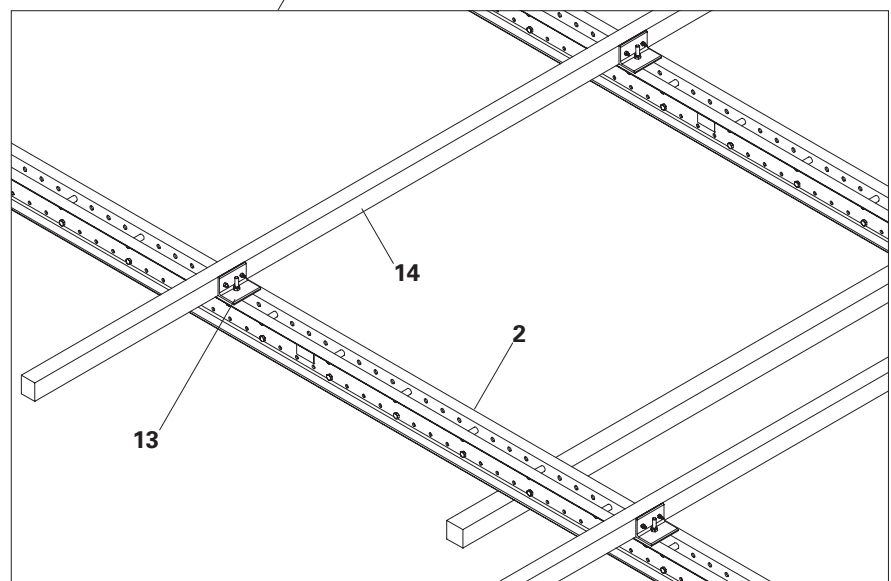

Fig. C1.06a

Mounting the framework

Components

2	Climbing Rail RCS
10	Crossbar RCS 103
12	Diagonal Strut RCS 212
40	Platform beam (squared timber)
91	Bolt ISO 4017 M12 x 240-8.8
94	Bolt ISO 4014-M24 x 130-8.8
95	Hex. Nut ISO 7042-M24-8
96	Nut ISO 4032 M12-8
97	Washer ISO 7093 200HV, A12

Assembly

1. Bolt on crossbar (**10**) and diagonal strut (**12**) with the bolts M24 x 130 (**94**) and nuts M24 (**95**) provided. Fold down the diagonal strut.
2. Position crossbar (**10**) vertically and screw the platform beam (**40**) securely to the crossbar. For preparing the platform beams, see Section "C2 Assembly of the work platforms" on page 80.
3. Temporarily clamp truss girders on which no work platform is mounted using a screw clamp and squared timber.

(Fig. C1.07 + C1.07a)



Depending on the organisation of work, pre-assembled work platforms can be mounted up to the outer decking transom.

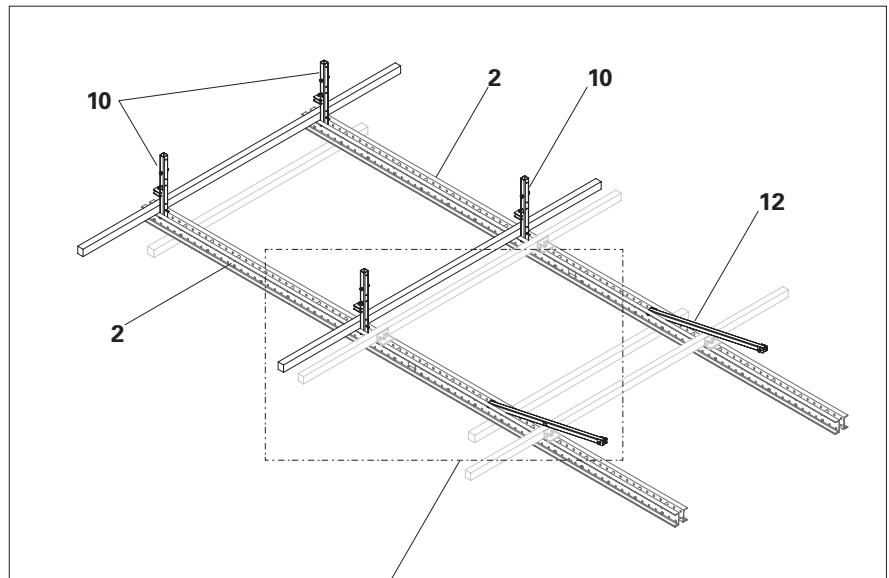

Fig. C1.07

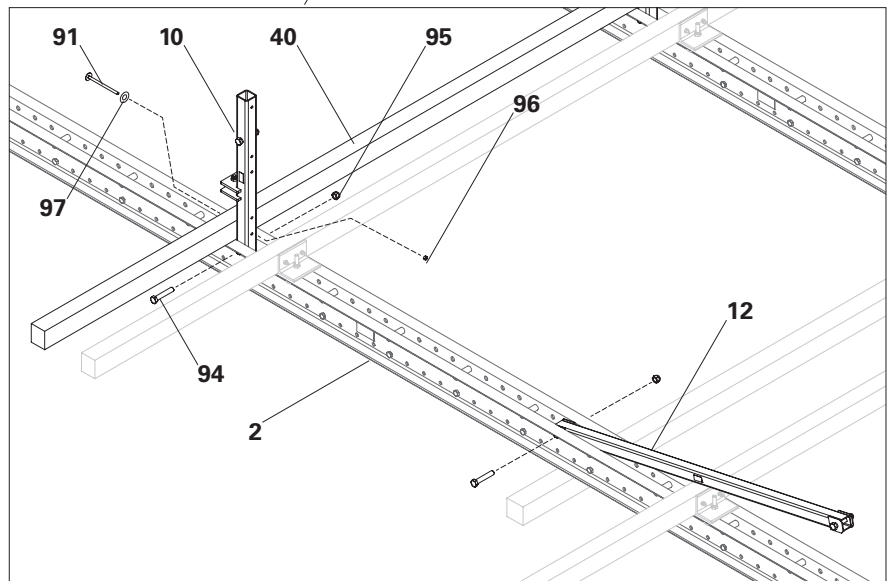

Fig. C1.07a

Mounting the enclosure posts

Components

- 1.2** Climbing Rail RCS 748
- 2** Climbing Rail RCS
- 10** Crossbar RCS 103
- 94** Bolt ISO 4014-M24 x 130-8.8
- 95** Hex. Nut ISO 7042-M24-8
- 12** Diagonal Strut RCS 212
- 40** Platform beam (squared timber)

Assembly

1. From above, position Climbing Rail RCS (**1.2**) as an enclosure post, with spacer \varnothing 26 mm below, on the crossbar (**10**).
2. Screw the enclosure post on the crossbar securely using bolts M24 x 130 (**94**) and nuts M24 (**95**). (Fig. C1.08)
3. Align the enclosure post with the crane until the crossbar is in a vertical position.
4. Fold down the bottom diagonal strut (**12**) and secure to the enclosure post (**1.2**) with bolt (**94**) and nut (**95**). (Fig. C1.08 – C1.08a)

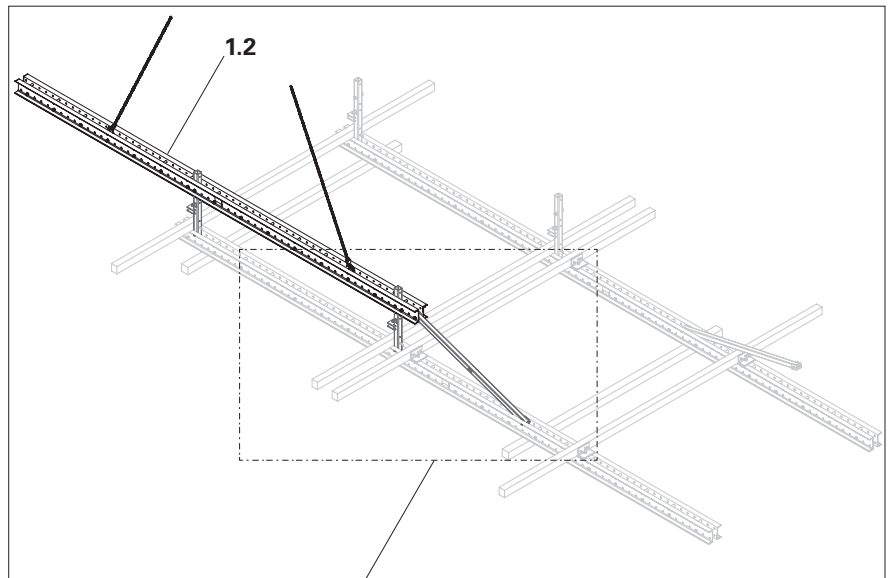

Fig. C1.08

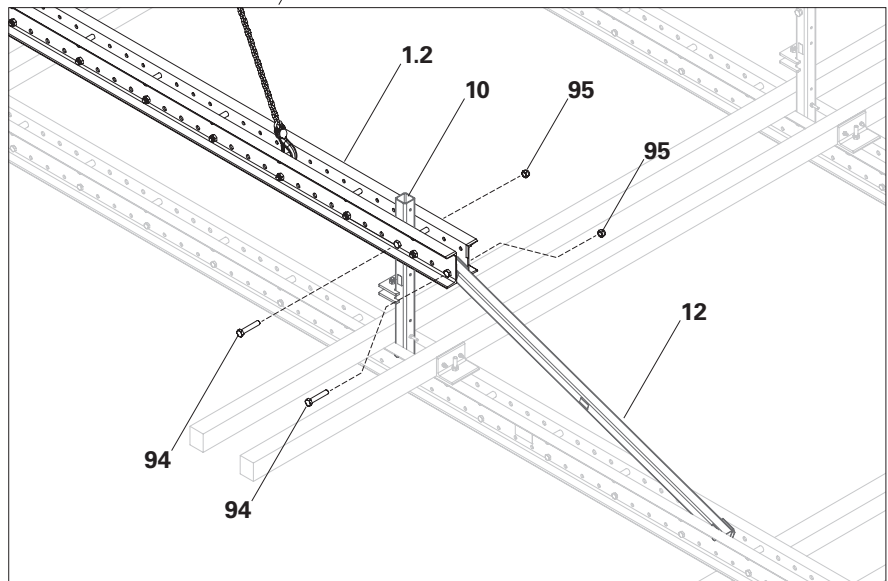

Fig. C1.08a

C1 Pre-assembly of console brackets

5. Install the middle diagonal strut (**12**) using bolts M24 x 130 (**94**) and nuts M24 (**95**). (Fig. C1.09a)
 6. Release the enclosure post from the crane.
 7. Mount additional enclosure posts.
 8. Check for right-angled and parallel alignment in all directions before proceeding with assembly operations. For fixing, mount diagonal bracing if necessary.
- Bracket framework variant 2 has now been mounted. (Fig. C1.09)

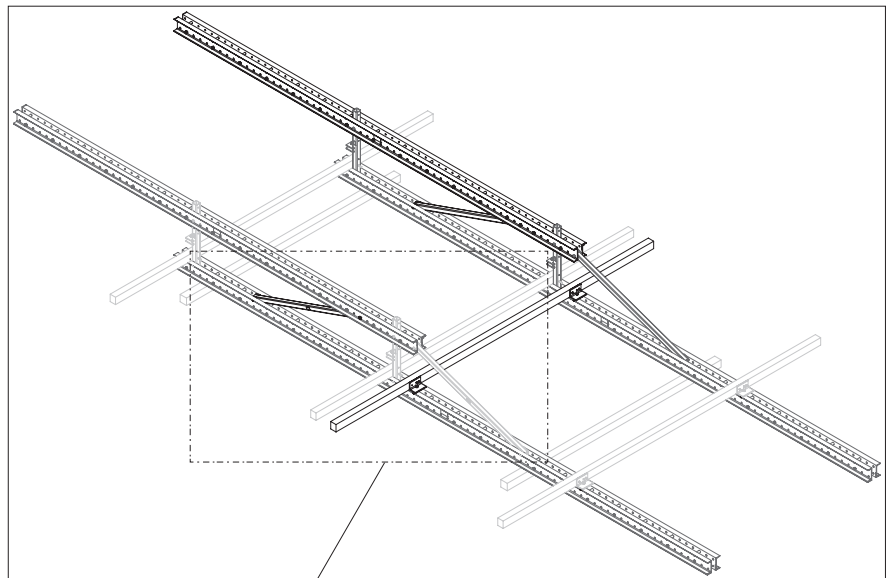

Fig. C1.09

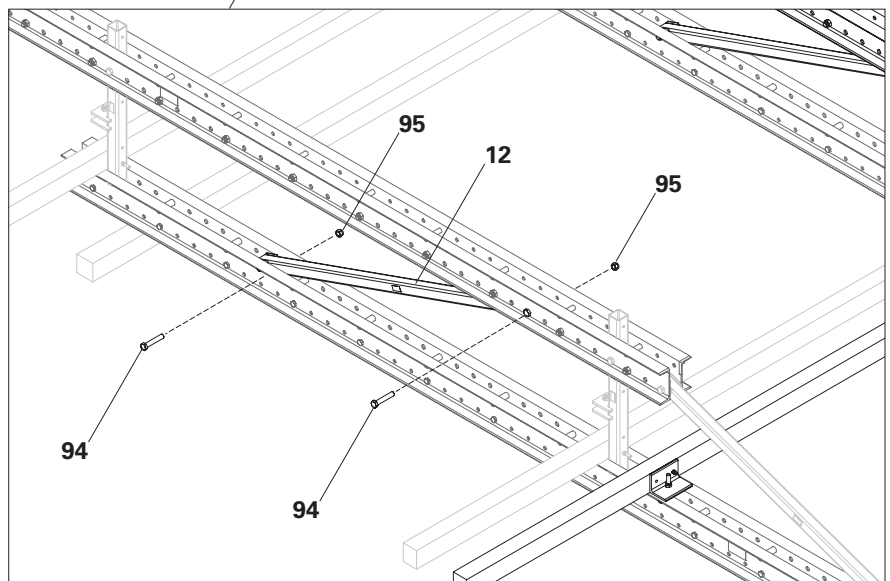

Fig. C1.09a

Overview of the bracket framework

(Enclosure post and girder not shown in order to provide a better overview)

Variant 1

Components

- 1.1 Climbing Rail RCS 348 or 498
- 2 Climbing Rail RCS
- 11 Crossbar RCS 69
- 94 Bolt ISO 4014-M24 x 130-8.8
- 95 Hex. Nut ISO 7042-M24-8

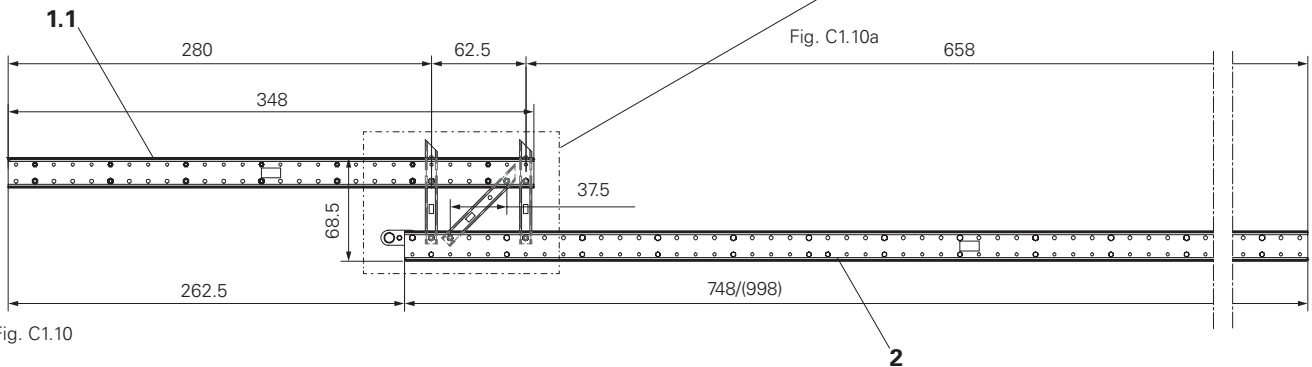
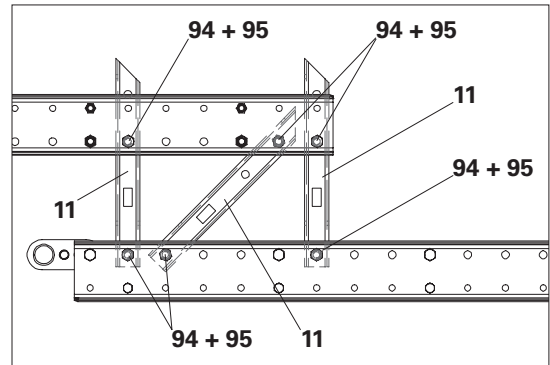

Fig. C1.10

Variant 2

Components

- 1.2 Climbing Rail RCS 748
- 2 Climbing Rail RCS
- 10 Crossbar RCS 103
- 12 Diagonal Strut RCS 212
- 94 Bolt ISO 4014-M24 x 130-8.8
- 95 Hex. Nut ISO 7042-M24-8

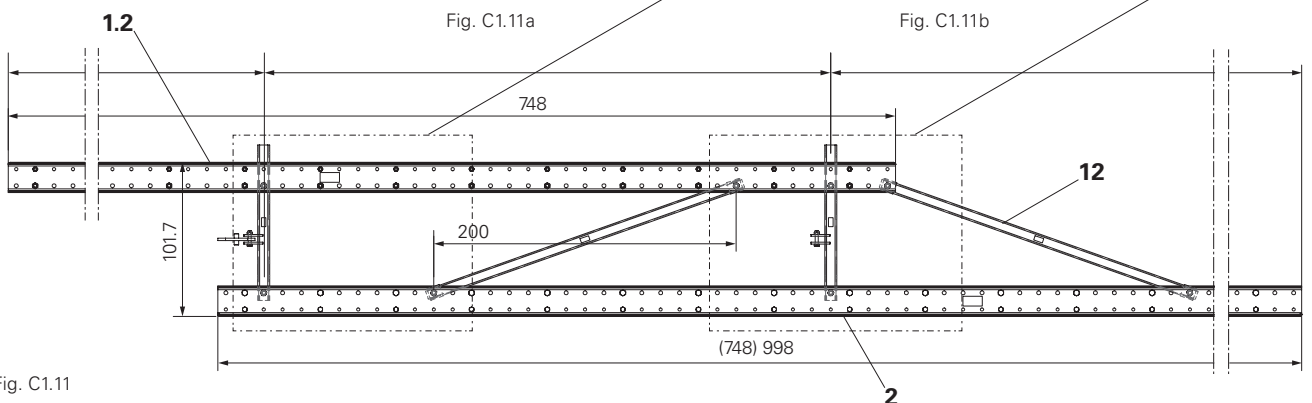
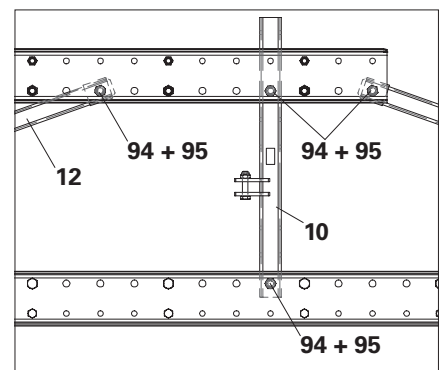
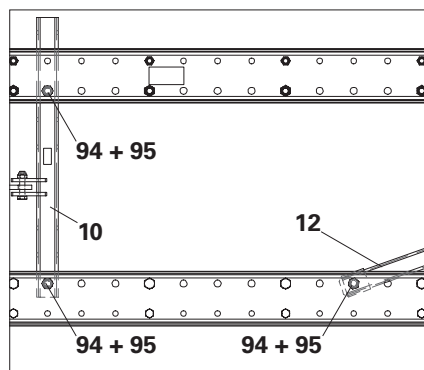

Fig. C1.11

Variant 3

Components

- 1.2 Climbing Rail RCS 748
- 1.3 Climbing Rail RCS 248
- 1.4 Climbing Rail RCS 148
- 2 Climbing Rail RCS
- 10 Crossbar RCS 103
- 12 Diagonal Strut RCS 212
- 31 Climbing Rail Connector RCS 73
- 94 Bolt ISO 4014-M24 x 130-8.8
- 95 Hex. Nut ISO 7042-M24-8

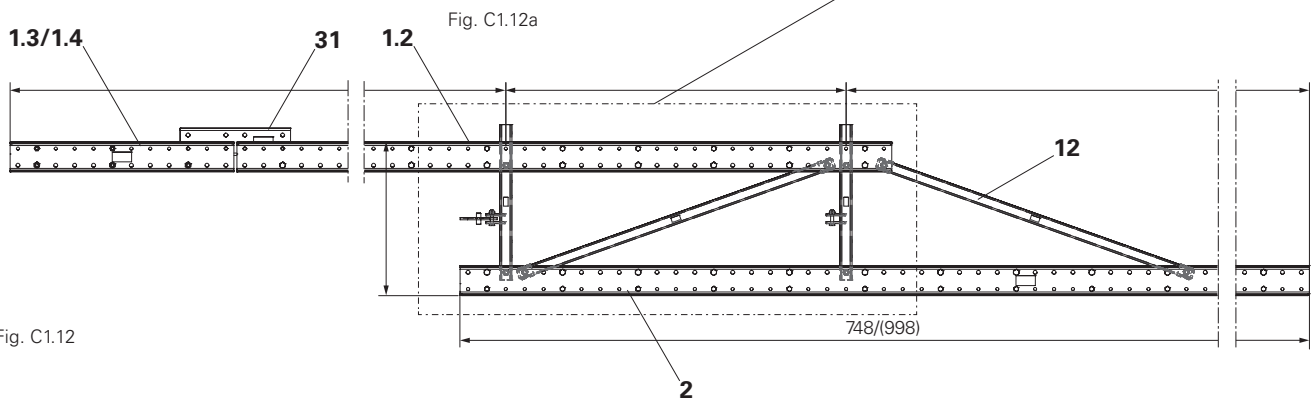
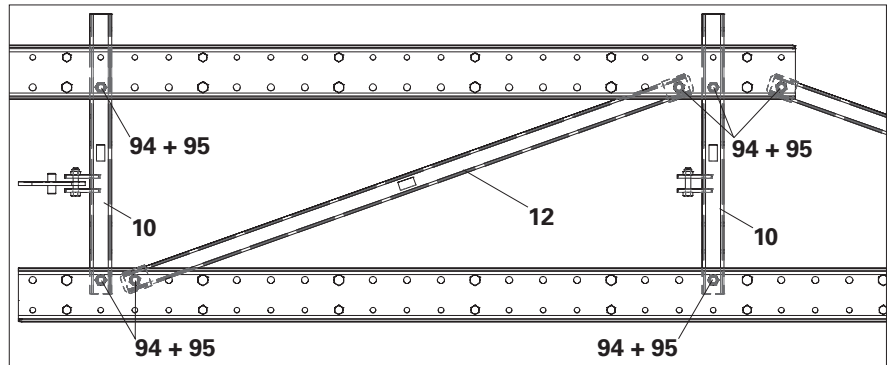

Fig. C1.12

Variant 4

Components

- 2.4 Climbing Rail RCS 348
- 2 Climbing Rail RCS
- 31 Climbing Rail Connector RCS 73

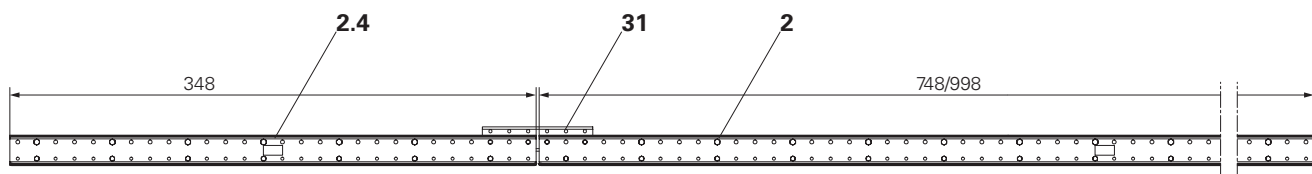

Fig. C1.13

General

Cut the squared timber and platform decking according to site-specific planning documents.

Work platforms for variant 2 and 3 can be pre-assembled up to the platform beam.

Installing the platform beams

Screw the platform beams (squared timber) onto the truss girder.

Components

10	Crossbar RCS 103
40	Platform beam (squared timber)
91	Bolt ISO 4017 M12 x 240-8.8
96	Nut ISO 4032 M12-8
97	Washer ISO 7093 200HV, A12

Assembly

- Countersink the platform beam (**40**) by at least 15 mm, e.g. with a Forstner drill \varnothing 45 mm, so that the planking does not project on the screw head.
For squared timbers more than 160 mm thick, increase the countersink depth.
Countersink depth $x =$
squared timber thickness $d - 145$ mm
- Drill squared timber with \varnothing 14 mm.
- Insert bolt M12 x 240 (**91**) with washer (**97**) through the hole in the squared timber and crossbar, and tighten with nut (**96**). For the bolt M12 x 240, the maximum clamping length is $a = 220$ mm.

(Fig. C1.07)

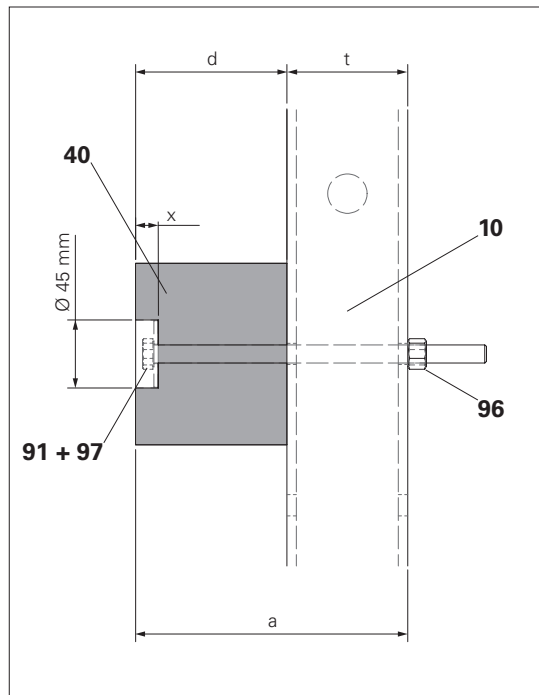

Fig. C2.01

Mounting the platform decking and toe boards

The platform decking must be tightly installed and flush with the enclosure. Close all open edges with toe boards.

Components

10	Crossbar RCS 103
11	Crossbar RCS 69
37	Work platform decking (planks)
39	Toe board
39.1	Angle Connector 90° reinforced
40	Platform beam (squared timber)
98	TSS-Torx 6 x 80
110	Spax Screw TX30, 6 x 20

Assembly

1. Secure each individual plank (**37**), 2x per intersection with each platform beam, with screws 6 x 80 (**98**).
2. Screw the Angle Connector 90° reinforced (**39.1**) securely to the planking at a distance of approx. 100 cm using Spax Screws TX30, 6 x 20 (**110**).
3. Screw the toe boards to the Angle Connector 90° reinforced with Spax Screws TX30, 6 x 20.
4. Fix toe boards (**39**) to corners with Spax Screw TX30, 6 x 20 (**110**).



Cantilevered planking or cut-to-size decking made of multi-layer plywood sheeting is to be secured against lifting.

Requirements for decking and toe boards, see Section "B2 Planning of the units".

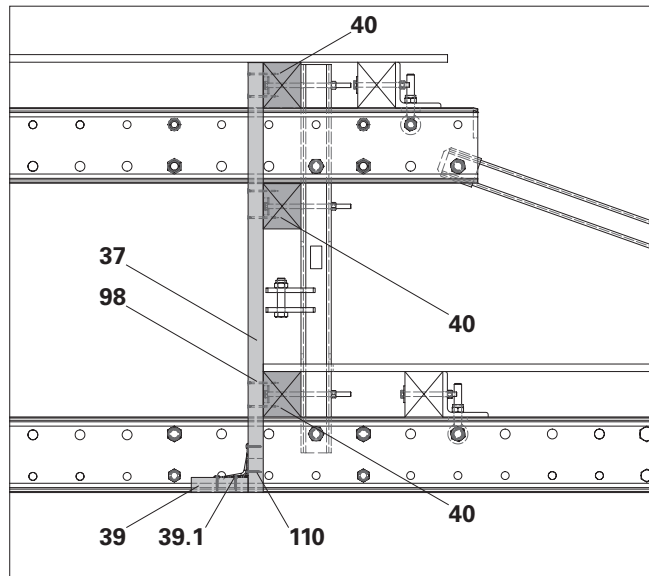

Fig. C2.02

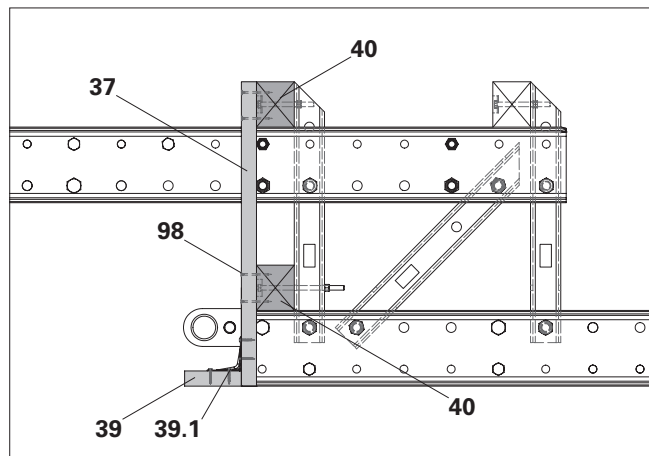

Fig. C2.02

Foldable cover

Assembly on the scaffolding tube

Components

- 2** Climbing Rail RCS
- 41** Foldable cover (multi-layer plywood sheeting)
- 80** Steel scaffolding tube \varnothing 48.3 x 3.2
- 137** Scaffold Tube Holder LPS/RCS \varnothing 48
- 138** Flap Hinge LPS D48/M10
- 139** Flap Safety Plate LPS D=48 RCS
- 150** Reinforcement bar

Assembly

1. Mount scaffold tube holder (**137**) on the climbing rail (**2**) with fitting pin and cotter pin. The assembly position is specified in the planning documents.
2. As a transport locking device, screw one reinforcement bar (**150**) into both climbing rails with cam nuts. The reinforcement bar on the outer side must not project over the enclosure. (Fig. C2.03 – C2.03a)

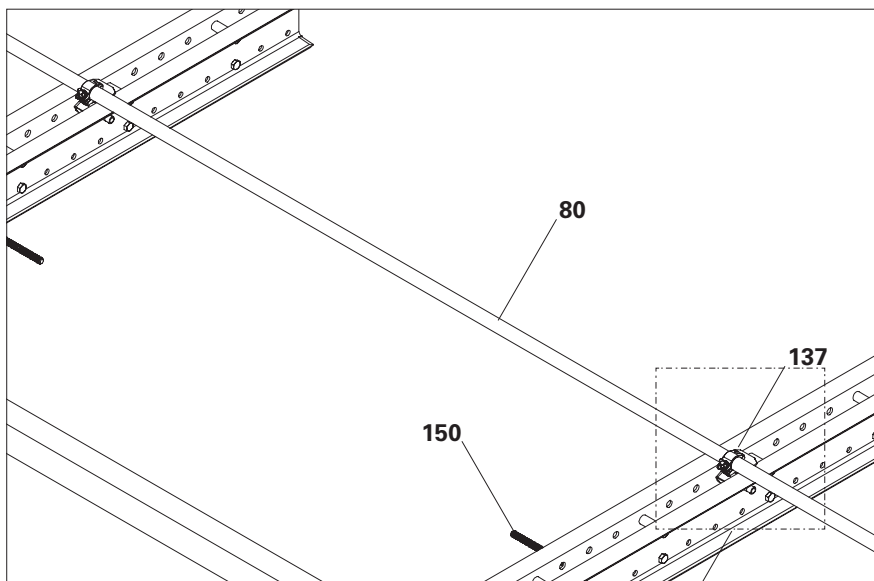

Fig. C2.03

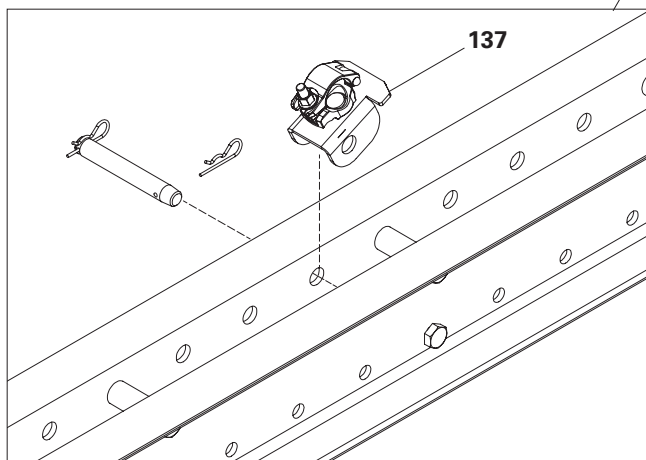

Fig. C2.03a

C2 Assembly of the work platforms

3. Cut the multi-layer plywood sheeting (**41.1**) to required size and pre-drill with $\varnothing 11$ mm.
4. Mount flap hinges (**138**) with the bolts M10x50-8.8 (**138.1**) and washers provided. For the permissible arrangement, see "Fig. B2.06" on page 46 and "Tab. B2.02" on page 46.
5. Mount the foldable cover (**41**) on the scaffolding tube (**80**) and place on the reinforcement bar (**150**).
6. For each foldable cover, mount at least one flap safety plate (**139**) approximately in the centre using 2 SPAX Screws TX 30 8x20. Foldable cover is now secured. (Fig. C2.04)

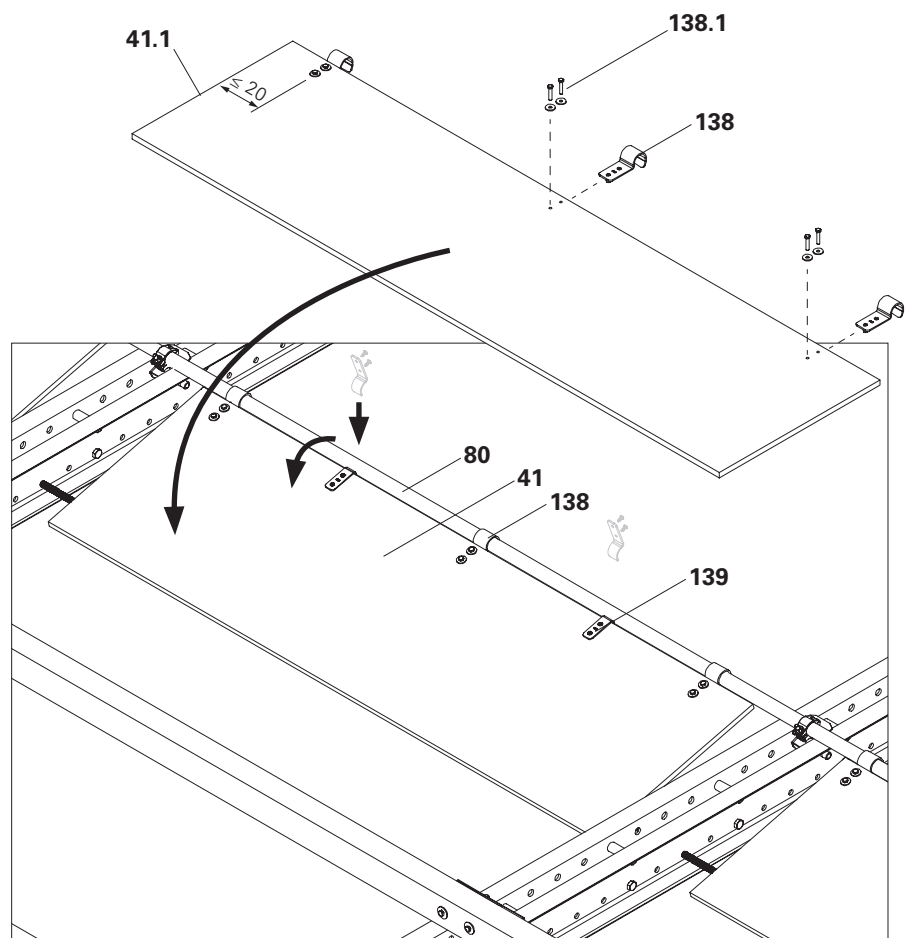

Fig. C2.04

Assembly on the enclosure beam

Components

- 14** Enclosure beam (squared timber)
- 14.1** Support (squared timber)
- 41** Foldable cover (multi-layer plywood sheeting)
- 42** Hinge DIN 7957-200-ST
- 109** Spax Screw TX25, 5 x 20
- 111** Spax Screw TX30, 6 x 120
- 136** Fixation Bar RCS

Assembly

1. Position the pre-assembled enclosure beam (**14**), turned by half a turn, on the climbing rails.
2. As support (**14.1**) for the foldable cover, chamfer one squared timber to approx. 30°.
3. Screw the support (**14.1**) with screws 6 x 120 (**111**) at a distance of approx. 60 cm to the enclosure beam (**14**). (Fig. C2.05)

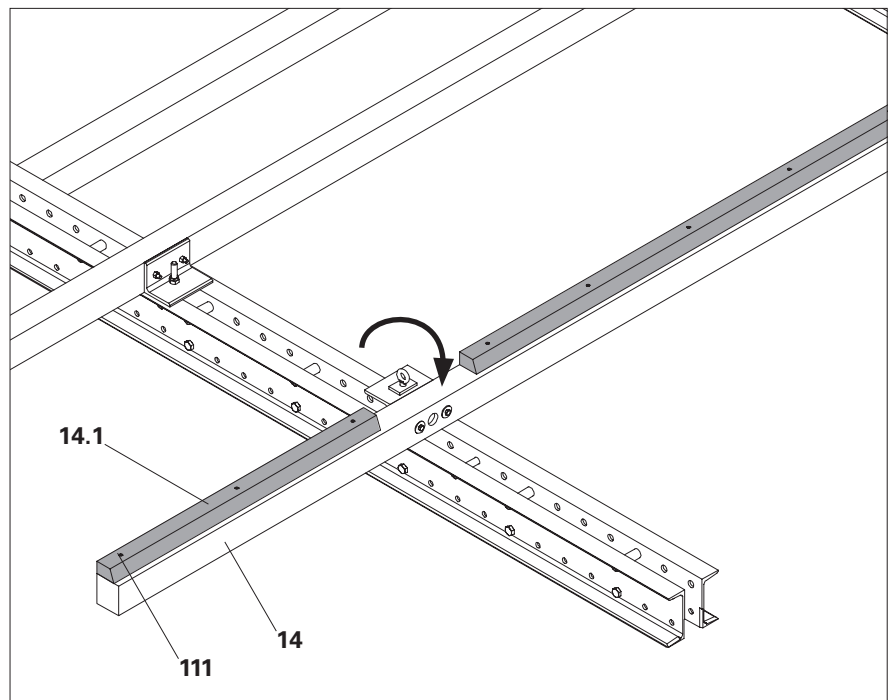

Fig. C2.05

3. Cut foldable cover **(41)** made of weather-resistant multi-layer plywood sheeting according to site-specific assembly drawings.
4. On the enclosure side **(41.1)**, chamfer the edges to under approx. 30°.
5. Secure each flap to the enclosure beam using at least 2 hinges **(42)**. Secure hinges to flap and enclosure beam using 2 x 4 screws 5 x 20 **(109)**. (Fig. C2.06 + C2.06a)
6. Turn the enclosure beam back half a turn and mount on the climbing rails using the eyelets. See Section "C3 Assembly of the enclosure" on page 84. (Fig. C2.07)
7. Provide a fixation bar **(136)** for each cover for the opened position. Secure each fixation bar to the enclosure using 4 screws 5 x 20 **(109)**. The position is given in the project-specific planning documents.

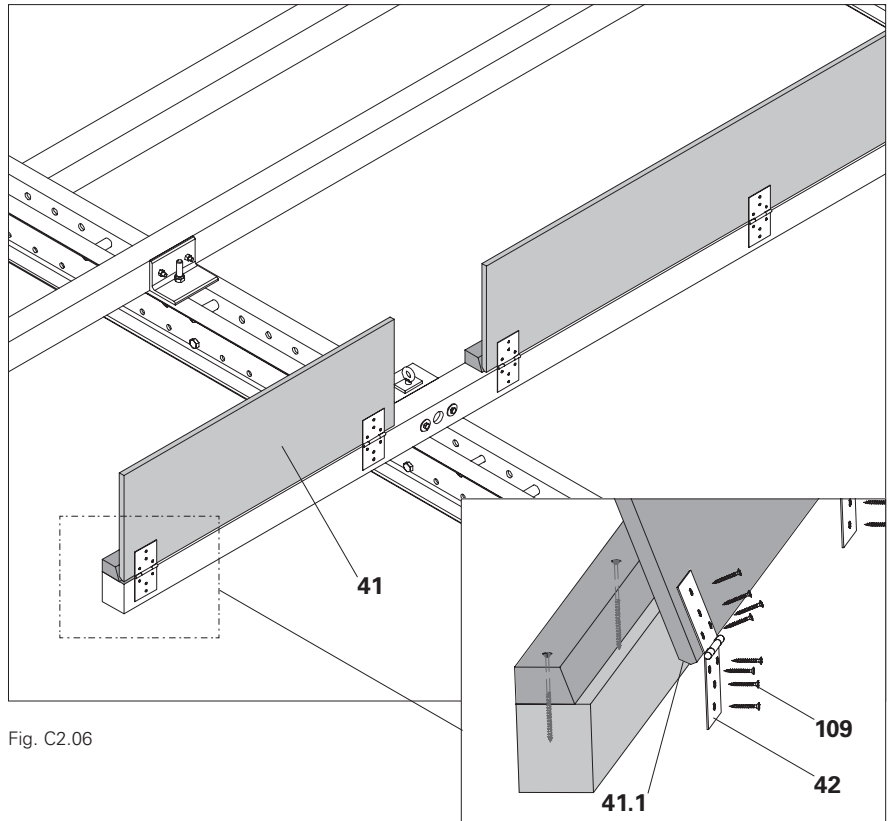

Fig. C2.06

Fig. C2.06a

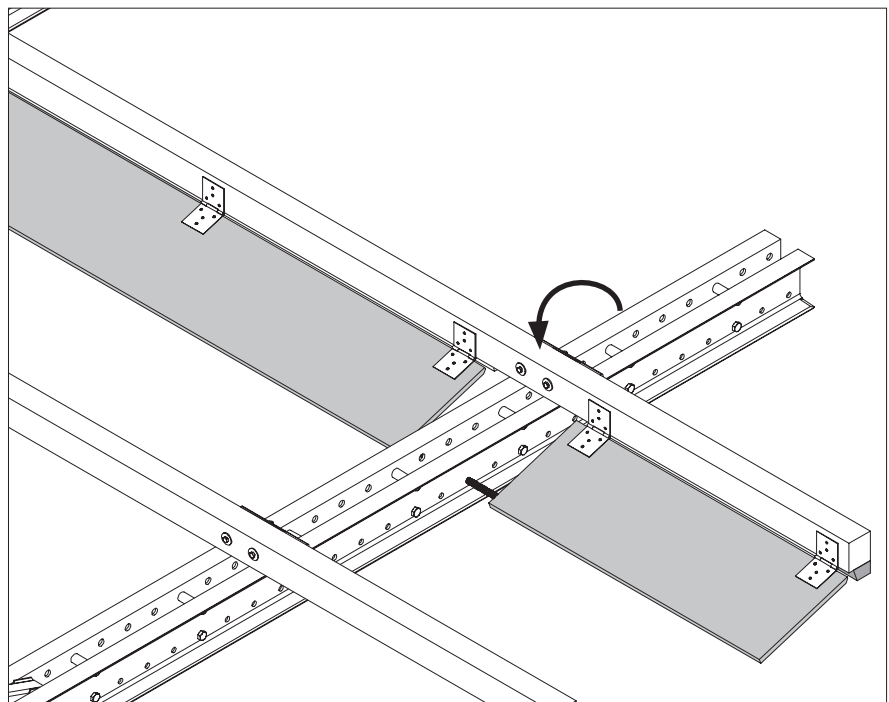

Fig. C2.07

Mounting the squared timber adapter

Enclosure beams (squared timbers) are attached to the climbing rail or enclosure post by means of the squared timber adapter.

Components

- 1** Climbing Rail RCS
- 13** Squared Timber Adapter RCS 12/20
- 13.1** Eyebolt M20
- 13.2** Nut M20
- 13.3** Stop plate
- 14** Enclosure beam (squared timber)
- 23** Plate connector Ø 48/12 mm
- 92** Bolt ISO 4014-M20 x 120-8.8
- 93** Hex. Nut ISO 7042-M20-8
- 94** Bolt ISO 4014-M24 x 130-8.8
- 95** Hex. Nut ISO 7042-M24-8

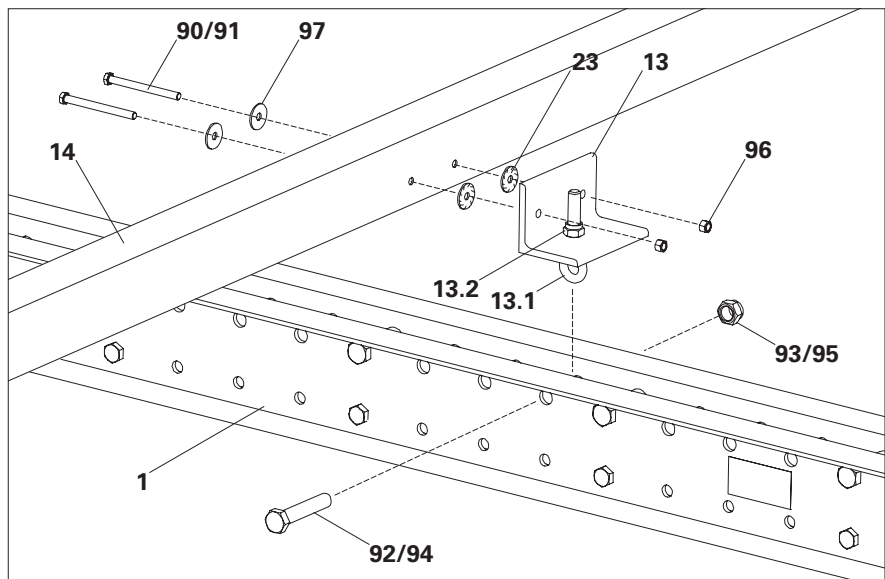

Fig. C3.01

Assembly

1. Adjust the projection of the eyebolt (**13.1**) with the nut (**13.2**) so that the eyelet corresponds to the hole of the climbing rail.
2. Position the squared timber adapter, with the stop plate (**13.3**) laterally turned, between the U-section of the climbing rail. The stop plate ensures the central alignment of the squared timber adapter on the climbing rail.
3. Insert bolts (**92/94**) through the holes in the climbing rail or enclosure post and eyelet (**13.1**). Secure bolts with nuts (**93/95**).
4. Tighten the nut on the eyebolt.
(Fig. C3.01 + C3.02)

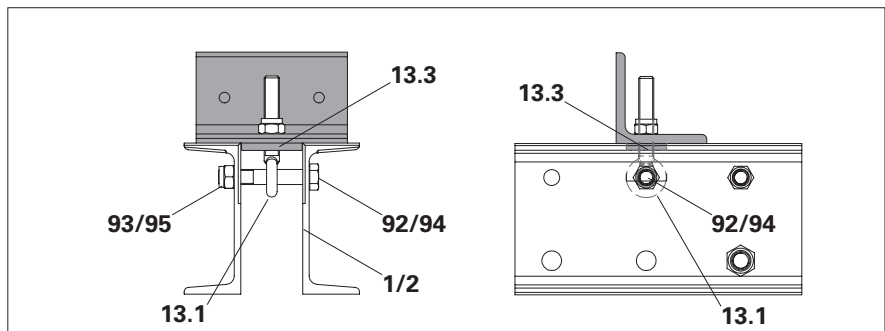

Fig. C3.02

Specified bolt connection

Rail	Hole	Screw	Nut
Climbing rail	Ø 26 mm	M24 x 130 (94)	M24-8 (95)
Enclosure post	Ø 20 mm	M20 x 120 (92)	M20-8 (93)

Tab. C3.01

Mounting the enclosure beam

The enclosure beams (squared timbers) ensure the required axial dimension A of the bracket unit during console bracket assembly. Adhere to the exact dimensions specified in the site-specific assembly drawings!

Components

- 1** Climbing Rail RCS
- 13** Squared Timber Adapter
RCS 12/20
- 13.4** Hole
- 14** Enclosure beam (squared timber)
- 23** Plate connector \varnothing 48/12 mm
- 90** Bolt ISO 4017 M12 x 140-8.8
- 91** Bolt ISO 4017 M12 x 240-8.8
- 96** Nut ISO 4032 M12-8
- 97** Washer ISO 7093 200HV, A12

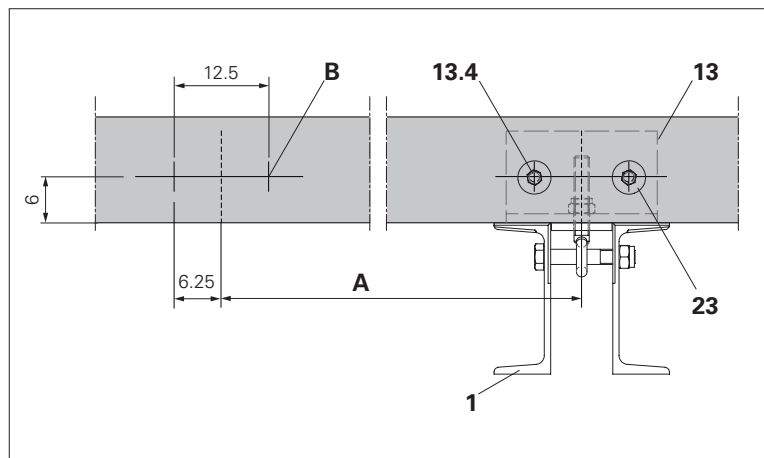

Fig. C3.03

Assembly

1. Carry over the position of console bracket axes A to the enclosure beam and mark drilled holes B which correspond to Fig. C3.03.
2. Place the squared timber adapter (**13**) in the subsequent mounting position as a drilling jig. Drill squared timber with \varnothing 12 mm. (Fig. C3.03)
3. If statically required: hammer plate connectors (**23**) congruently into the holes of the enclosure beam, on the side of the squared timber adapter. Secure the plate connectors with wire pins. (Fig. C3.01)
4. Depending on the clamping length (squared timber height), insert bolts M12 x 140 (**90**) or M12 x 240 (**91**) through the holes of the squared timber adapter and enclosure beam. Secure bolt with washer (**97**) and nut (**96**). (Fig. C3.01)

Mounting the Girder VT 20

Use the Adapter VT 20/RCS-P when mounting the Girder VT 20 as an enclosure beam. Adhere to the exact dimensions specified in the site-specific assembly drawings!

Components

- 1** Climbing Rail RCS
- 7** Girder VT 20
- 15** Adapter VT 20/RCS-P
- 92** Bolt ISO 4014-M20 x 120-8.8
- 93** Hex. Nut ISO 7042-M20-8
- 94** Bolt ISO 4014-M24 x 130-8.8
- 95** Hex. Nut ISO 7042-M24-8
- 99** TSS-Torx 6 x 60

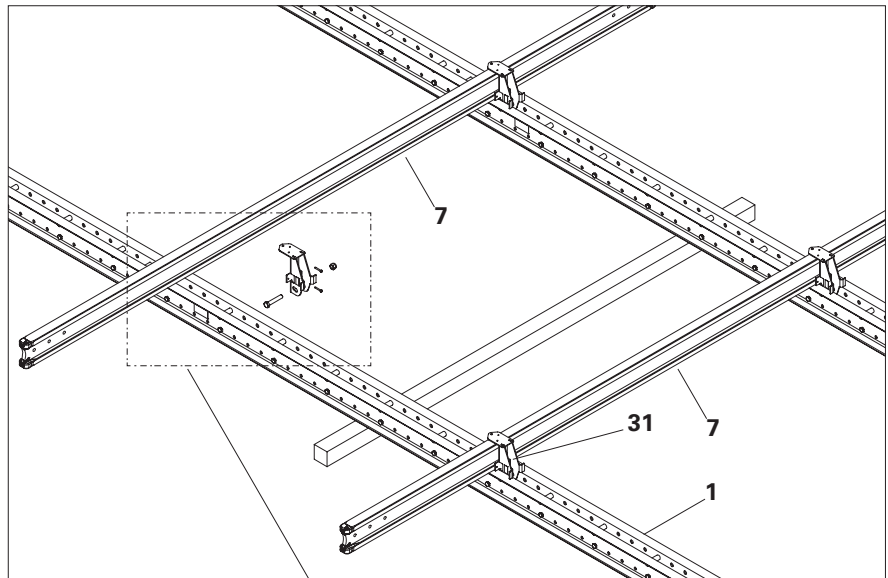

Fig. C3.04

Assembly

1. Align the climbing rails to the axis dimension.
2. Insert Adapter VT 20/RCS-P (**15**) with the support above into the climbing rail or enclosure post.
2. Insert bolts (**92/94**) through the holes in the climbing rail or enclosure post and adapter (**15**). Secure bolts with nuts (**93/95**). (Fig. C3.04a)
3. Align Girder VT 20 on the adapter (**15**) accordingly and secure with 2 Torx screws 6 x 60 (**99**) per adapter. Use the marked screw holes. (Fig. C3.04b)

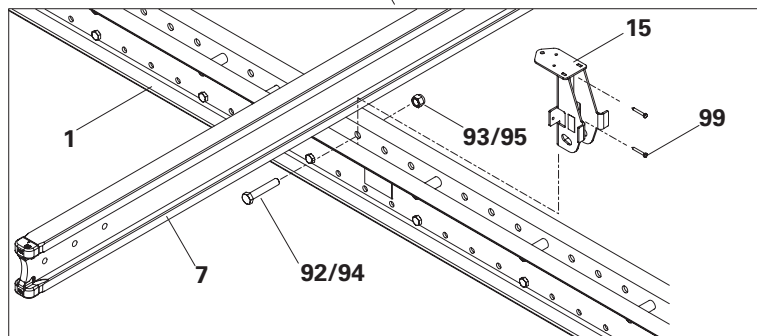

Fig. C3.04a

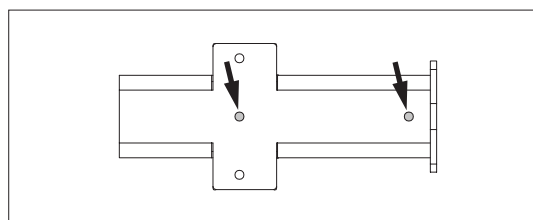

Fig. C3.04b

Specified bolt connection			
Rail	Hole	Screw	Nut
Climbing rail	Ø 26 mm	M24 x 130 (94)	M24-8 (95)
Enclosure post	Ø 20 mm	M20 x 120 (92)	M20-8 (93)

Tab. C2.01

Mounting the multi-layer plywood sheeting

The dimensions for cutting the multi-layer plywood sheeting, as well as screw spacing e , are provided in the site-specific assembly drawings.

Components

- 1** Climbing Rail RCS
- 14** Enclosure beam (squared timber)
- 18** Enclosure (multi-layer plywood sheeting)
- 99** TSS-Torx 6 x 60

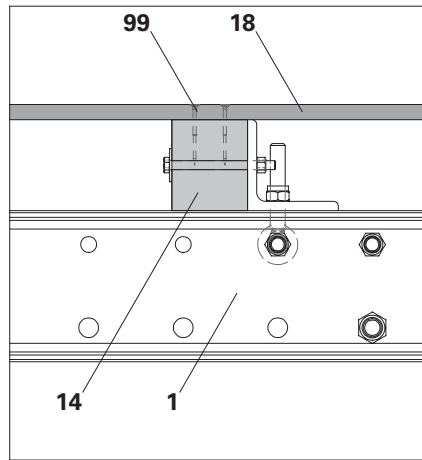

Fig. C3.05

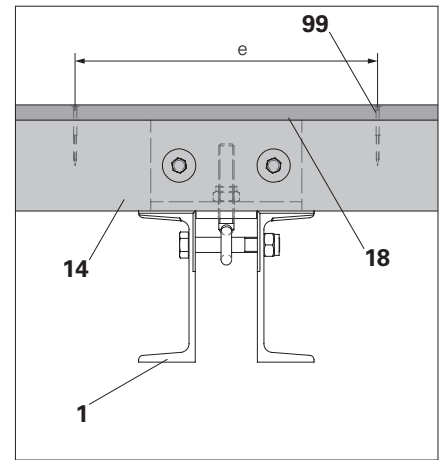

Fig. C3.05a

Assembly

1. Cut the multi-layer plywood sheeting according to the plans, position on the enclosure beams and align.
2. Mark the position of the enclosure beam, e.g. with a chalk line, and mark bolt positions according to site-specific assembly drawings.
3. Push the multi-layer plywood sheeting to one side and pre-drill with $\varnothing 7$ mm. Do not pre-drill the enclosure beam.
4. Align the multi-layer plywood sheeting and secure on the enclosure beam using Torx Screws (**99**).

(Fig. C3.05 + C3.05a)

Cover for Variant 1



In order to provide protection against falling objects, a non-accessible covering made of multi-layer plywood sheeting is to be installed in Variant 1.

Components

- 1** Climbing Rail RCS
- 14** Enclosure beam (squared timber)
- 18** Enclosure (multi-layer plywood sheeting)
- 87** Squared timber 50 x 50
- 98** TSS-Torx 6 x 80
- 99** TSS-Torx 6 x 60

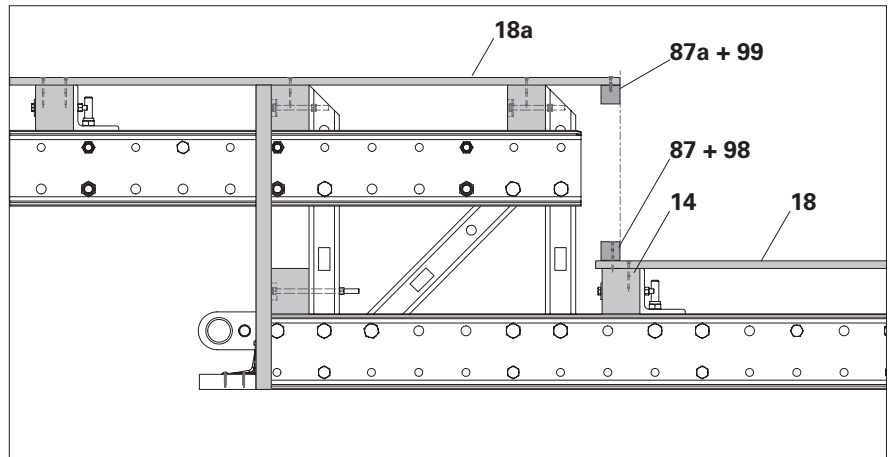

Fig. C3.06

Assembly

1. Mount the enclosure panel (**18**) on the climbing rail so that the top enclosure beam (**14**) is completely covered.
2. Pre-drill squared timber 50 x 50 (**87**) with \varnothing 7 mm and secure with screws 6 x 80 (**98**) to the enclosure beam.
3. Align the enclosure panel (**18a**) on the enclosure post so it is flush with the squared timber (**87**) on the enclosure beam.
4. Secure squared timber 50 x 50 (**87a**) to pre-drilled enclosure panel (**18a**) with screws 6 x 60 (**99**). (Fig. C3.06)
5. Pre-drill cover sheet (**18b**) and fix to squared timbers (**87 + 87a**) using screws 6 x 60 (**99**). (Fig. C3.06a)

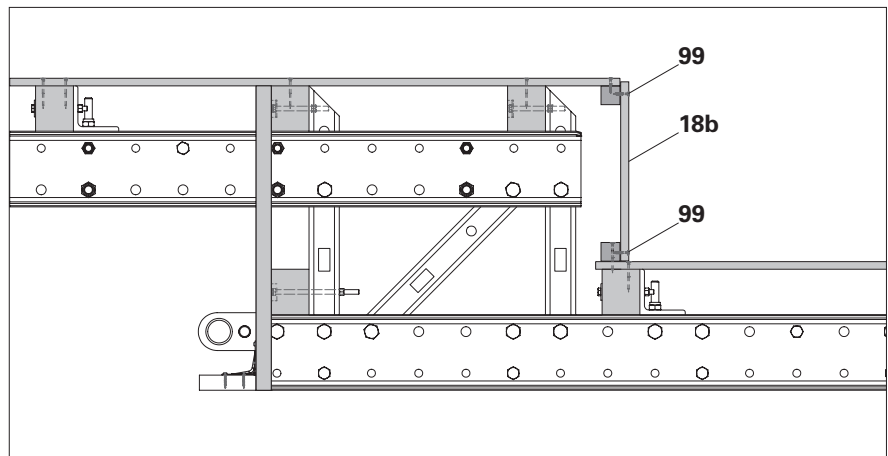

Fig. C3.06a

Mounting the trapezoidal metal sheeting



- To provide protection against falling objects: in the area of the work platforms and hinged covers, cover the cavities between the trapezoidal metal sheeting and the squared timbers.
- The dimensions for cutting the trapezoidal metal sheeting, as well as screw spacing e , are provided in the site-specific assembly drawings.

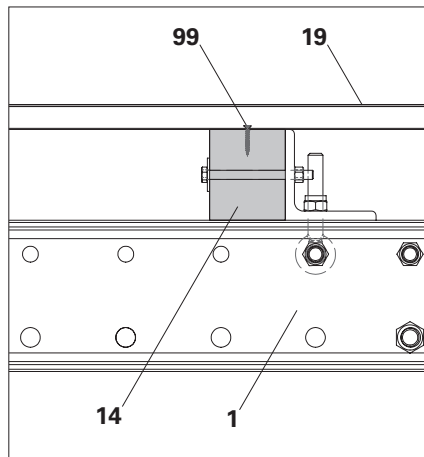

Fig. C3.07

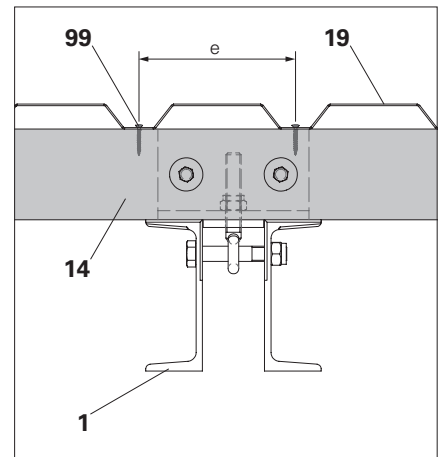

Fig. C3.07a

Components

- | | |
|-----------|--|
| 1 | Climbing Rail RCS |
| 14 | Enclosure beam (squared timber) |
| 19 | Enclosure (trapezoidal metal sheeting) |
| 99 | TSS-Torx 6 x 60 |

Assembly

1. Cut the trapezoidal metal sheeting according to the plans, position on the enclosure beams and align.
2. Mark the position of the enclosure beam, e.g. with a chalk line, and mark bolt positions according to site-specific assembly drawings.
3. Align the trapezoidal metal sheeting and fix to the enclosure beam using connection means recommended by the trapezoidal sheeting manufacturer.
4. Cover the cavities between the squared timber and trapezoidal sheeting, e.g. with Elastomer cover tape.

(Fig. C3.07 + C3.07a)

Mounting the protection edges

Secure the protection edges to the enclosure beams according to the site-specific assembly drawings. For mounting the protection edges, the enclosure beams are shortened by approx. 20 mm.

Components

- 14** Enclosure beam (squared timber)
- 18** Enclosure (multi-layer plywood sheeting)
- 19** Enclosure (trapezoidal metal sheeting)
- 20** Protection edge
- 99** TSS-Torx 6 x 60

Assembly

1. Cut solid wood boards 30 mm thick to match dimension b. Dimension b depends on the thickness of the enclosure beam and the enclosure materials used. Chamfer protection edges on one side above and below approx. 10 mm.
 2. Fix the protection edges (**20**) to the front side of the enclosure beam (**14**) with screws 6 x 60 (**99**). Use 2 screws per enclosure beam.
- (Fig. C3.08 - C3.08c)

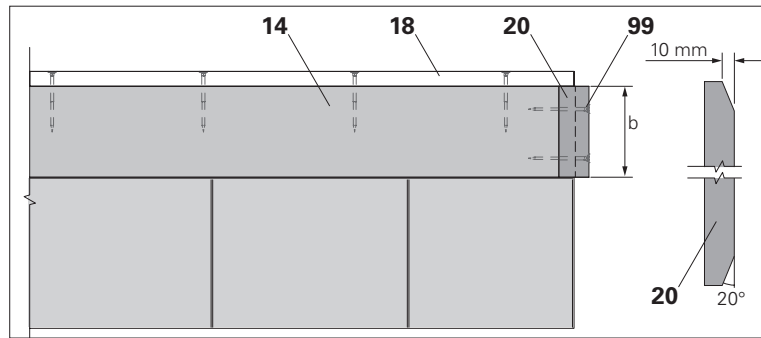

Fig. C3.08

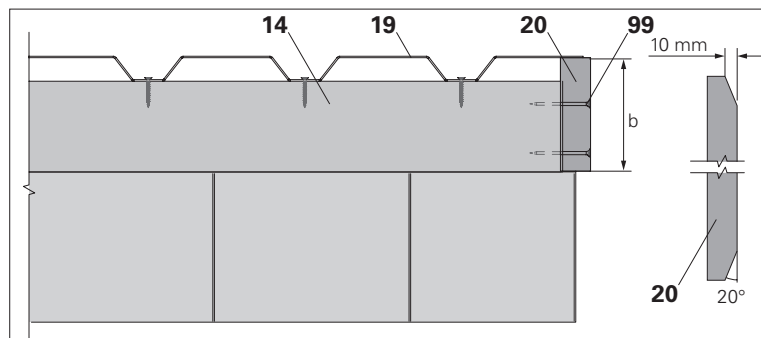

Fig. C3.08a

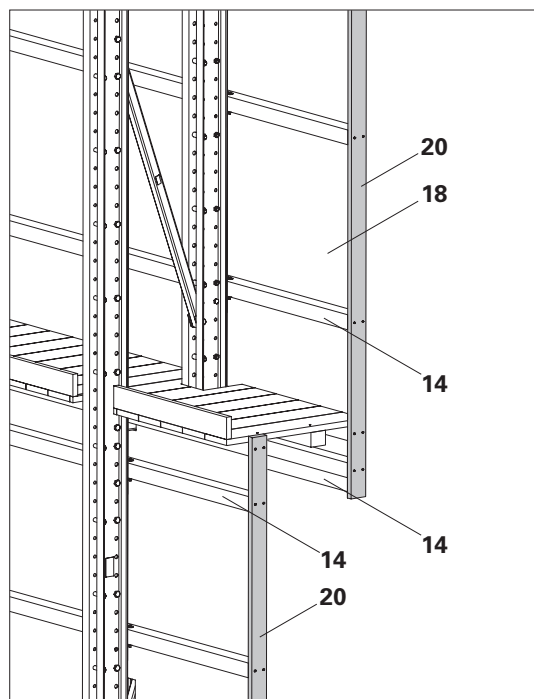

Fig. C3.08b

Scaffolding tubes with nets or tarpaulins



Mesh size for enclosure nets ≤ 20 mm.
Scaffolding tube spacing $a = 50$ cm.

Components

- 1** Enclosure post
- 3** Spacer M20-82
- 4** Spacer M24-82
- 80** Steel scaffolding tube
 $\varnothing 48.3 \times 3.2$
- 80.1** Steel scaffolding tube
 $\varnothing 60.3 \times 3.2$
- 83.1** Swivel Coupling DK 60/48
- 88** Safety net
- 88.1** Cable tie, UV-resistant
- 137** Scaffold Tube Holder \varnothing RCS

Mounting scaffolding tube $\varnothing 48$ mm

1. Remove cotter pins and bolts from scaffold tube holder (**137**).
2. Insert scaffold tube holder with retaining lug (**137.1**) into the drilled hole of the enclosure post (**1**).
3. Insert bolts (**137.2**) through the holes in the enclosure post and scaffold tube holder and secure with cotter pins (**137.3**).
4. Mount scaffolding tube $\varnothing 48$ mm (**80**) in the tube coupling. Tighten coupling nut with 50 Nm.
(Fig. C3.09)

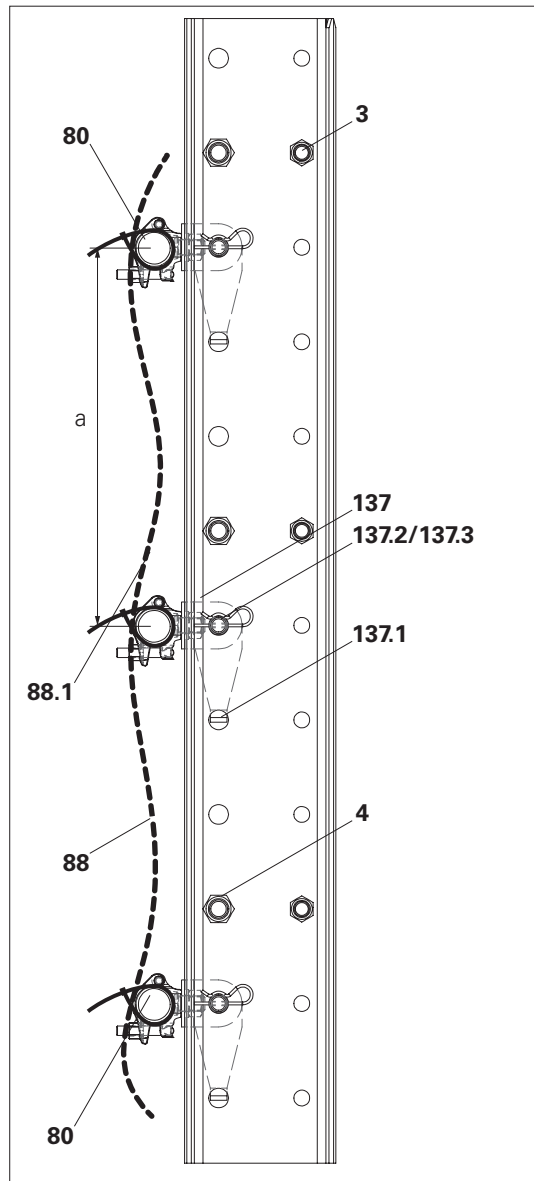

Fig. C3.09

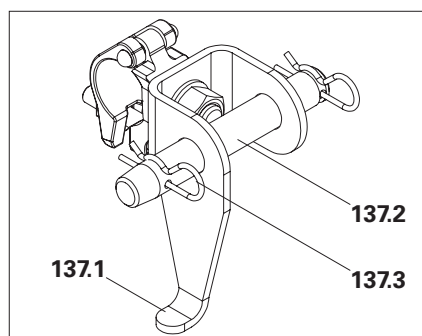

Fig. C3.09a

Mounting scaffolding tube Ø 60 mm

1. Install scaffolding tube sections Ø 48 mm, **(80.1)** L = 80 mm with spacers M20 **(3)** or M24 **(4)** into the enclosure post **(1)**.
2. Fit scaffolding tube Ø 60 mm to scaffolding tube sections with swivel coupling 60/48. Tighten coupling nut with 50 Nm.

(Fig. C3.09b)

Fitting safety nets

1. Attach the safety net according to the manufacturer information.
2. Guide the lower edge of the safety nets towards the building.
3. Ensure that there is a sufficient overlap with other parts of the enclosure.

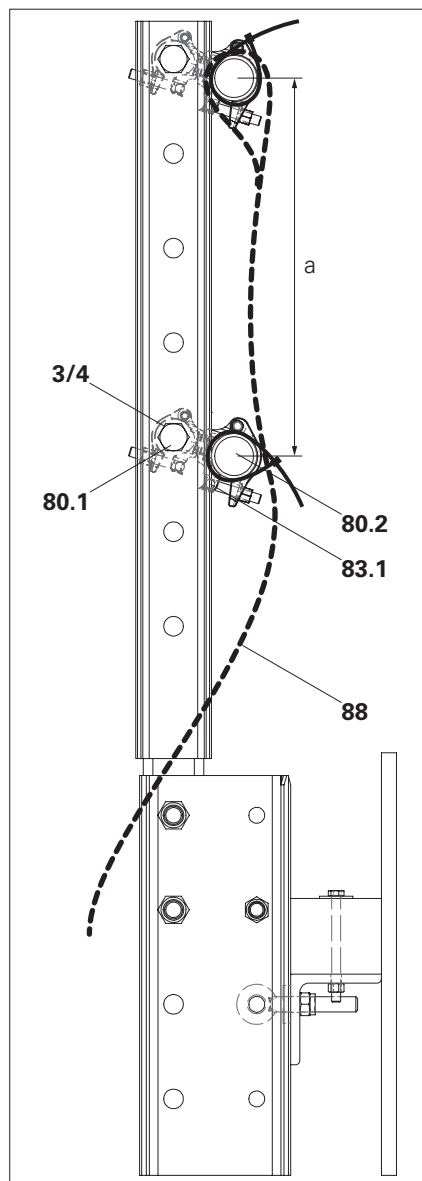

Fig. C3.09b

Attaching the climbing unit

Assembly

1. Fold up the pre-assembled foldable covers and attach to the enclosure using fixation bars.
2. Remove or secure all loose components.
3. Install bolt with cotter pin on the enclosure post as an attachment point for the crane lifting gear.
4. Cut out enclosure panels in the area of the crane lifting gear in order to prevent any damage when lifting. (Fig. C4.01)
5. Secure guide ropes to the climbing enclosure.
6. Attach crane lifting gear to the bolt.
7. Align and lift the climbing unit. (Fig. C4.02)

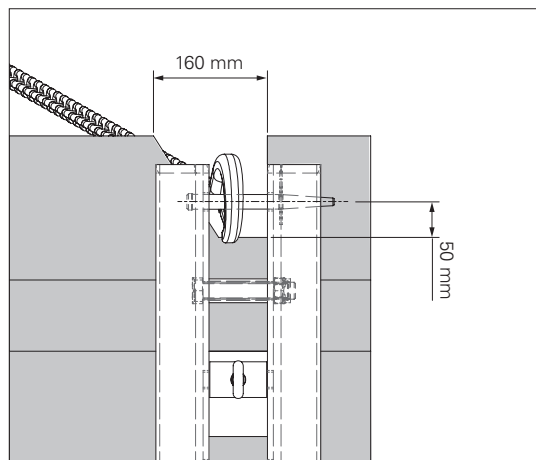

Fig. C4.01

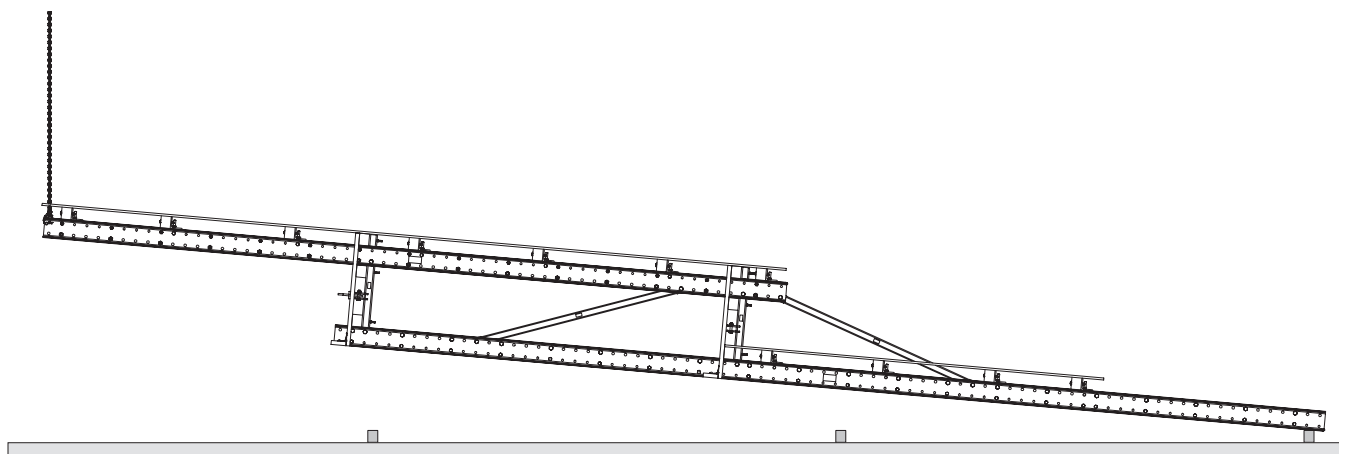

Fig. C4.02

Assembly of the climbing unit



Warning

- Risk of falling from unsecured building edges!
A fall can result in serious injury or even death.
⇒ Install guardrails.
⇒ Use personal protective equipment to prevent falling from a height (PPE).
- During assembly on the construction site, components may fall to the ground and hit people below!
This can lead to serious injuries or even death.
⇒ Cordon off danger zones beneath the working areas.
⇒ Release the climbing unit from the crane lifting gear only when all climbing shoes are closed and the climbing unit is resting fully on the lower slab shoes.

Components

- 44** Climbing Shoe RCS
- 44.1** Climbing pawl
- 44.2** Guiding skids
- 45** Slab Shoe RCS

Preparations

1. Mount required guardrails on all unsecured slab edges or ensure that PPE is used.
2. Attach top (**45a**) and bottom slab shoes (**45b**) to the slab.
3. Open the guiding skids (**44.2**) of the climbing shoes (**44a**) and (**44b**), see Section "Opening and closing the climbing shoe" on Page 120.
4. Lock the climbing pawl (**44.1**) of the bottom climbing shoe (**44b**) in order to prevent unintentional locking into place in the event $h_B = n \times 50$ cm.
5. Activate the climbing pawl of the top climbing shoe. See Section "Activating and deactivating the climbing pawl" on Page 122 (Fig. C4.03).

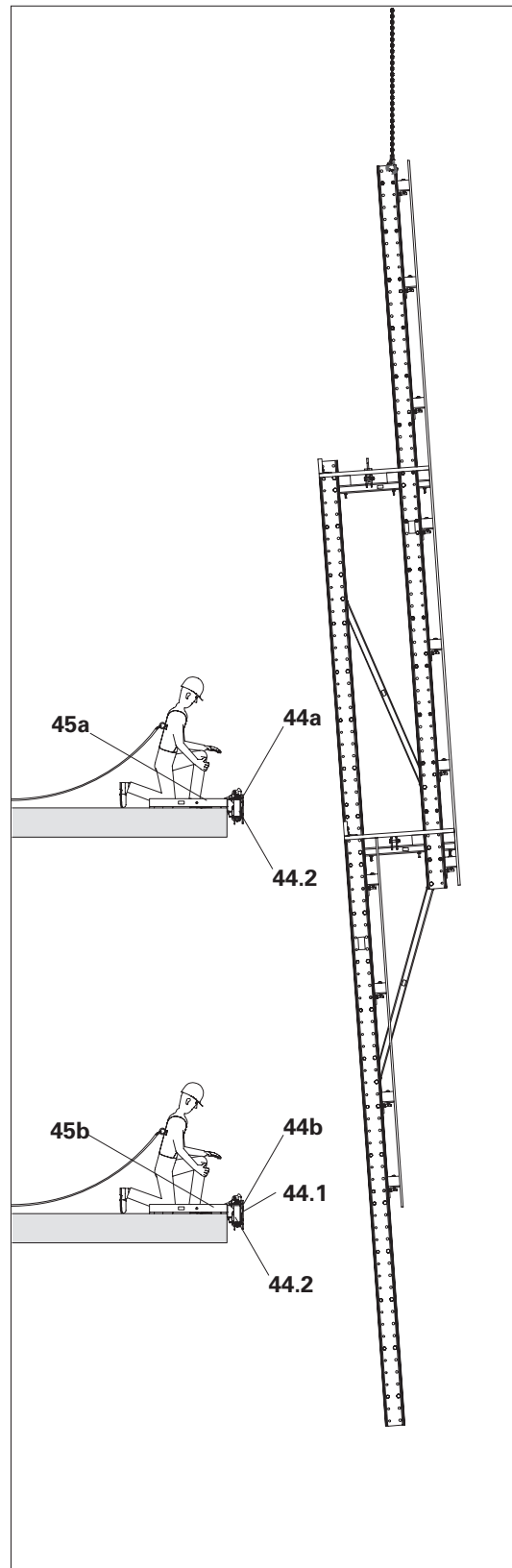

Fig. C4.03



Warning

Body parts can become trapped between climbing rails and slab shoes! This can result in serious injuries.

- ⇒ Do not take hold of anything between the rail guidance shoes and climbing rails.
- ⇒ Use the guide-in tool.
- ⇒ Guide the climbing enclosure with ropes.



- Immediately place the correct spacer (3) on the pawl (44.1) of the climbing shoe.
- In order to facilitate threading, do not tighten the tie bolt (44.6) until the climbing enclosure has been mounted.

Components

- 3 Spacer M20-82
- 44 Climbing Shoe RCS
- 44.1 Climbing pawl
- 44.2 Guiding skids
- 45 Slab Shoe RCS
- 126 Guide-In Tool RCS

Assembly

1. Position the climbing rail in front of the opened upper climbing shoe (44a). Use the guide-in tool (126). (Fig. C4.04a)
2. Close the guiding skids (44.2) of the top climbing shoe (44a) and secure, see Section "Opening and closing the rail guidance shoe" on Page 110.
3. Remove the guide-in tool (126).
4. Place the climbing enclosure with spacer (3) on the climbing pawl (44.1). (Fig. C4.04b)

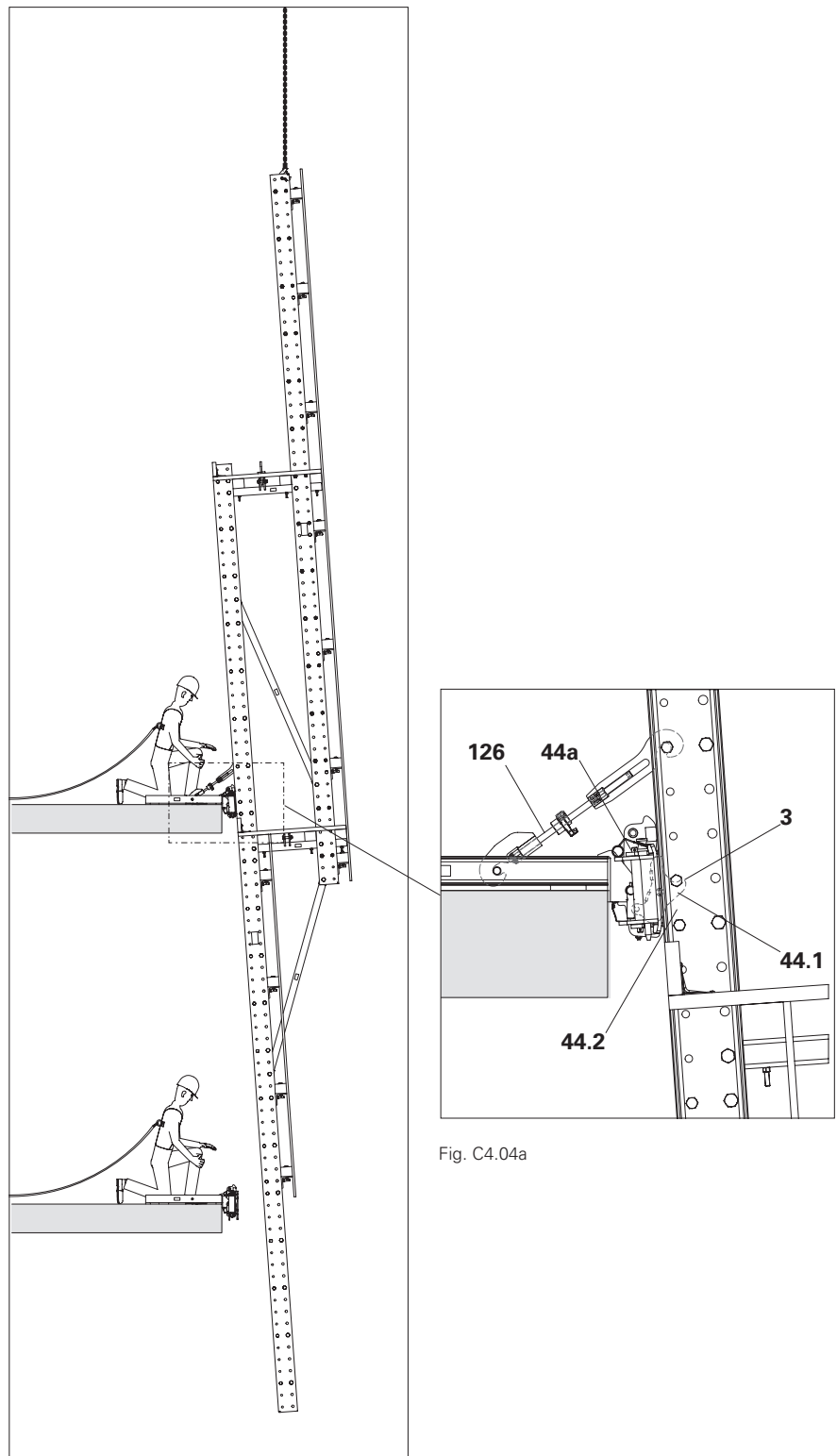

Fig. C4.04a

Fig. C4.04

C4 Attachment to the building

5. Continue to relieve the crane lifting gear and thereby position the climbing rail in front of the bottom climbing shoe (**44b**).
6. Close the guiding skids (**44.2**) of the bottom climbing shoe and secure.
7. Tighten the tie bolts (**44.6**) of all slab shoes.
8. Raise the climbing unit by approx. 10 cm.
9. Activate the climbing pawls of the bottom slab shoe and deactivate the top slab shoe. (Fig. C4.05 + C4.05a)
10. Relieve the crane of all loads and release crane lifting gear whilst standing in a safe position.

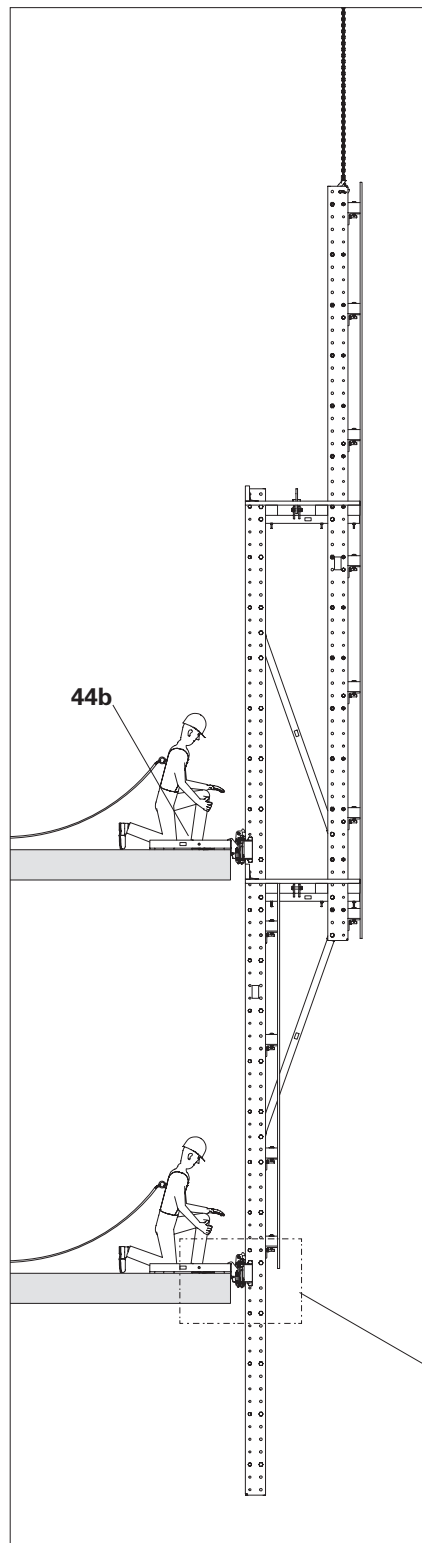

Fig. C4.05

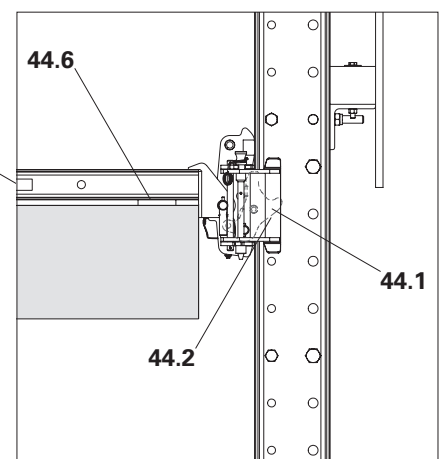

Fig. C4.05a

After mounting



Warning

- There is a risk of falling during assembly work on the suspended enclosure! A fall can result in serious injury or even death.
 - ⇒ Use personal protective equipment to prevent falling from a height (PPE).
- During assembly, for example, tools can fall down and strike people! Risk of injury
 - ⇒ Cordon off all danger zones below.

Components

- 41** Foldable cover (multi-layer plywood sheeting)
- 109** Spax Screw TX25, 5 x 20
- 136** Fixation Bar RCS

Assembly

1. Close the foldable covers.
2. If not yet installed: provide a fixation bar (**136**) for each cover for the opened position. Secure each fixation bar to the enclosure using 4 screws 5 x 20 (**109**).
3. If necessary, carry out adjustments, e.g. in the area of the climbing shoes.

(Fig. C4.06)

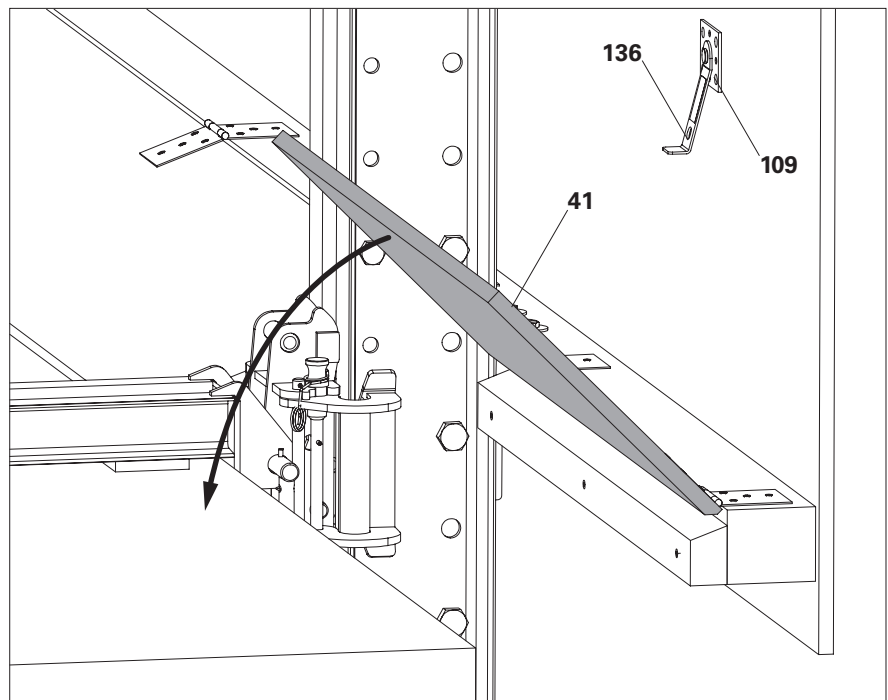

Fig. C4.06

Closing gaps

Components

- 41** Foldable cover (multi-layer plywood sheeting)
- 43** Cover Mat RCS 70 x 70
- 45** Slab Shoe RCS

Closing

1. Cover all gaps in the area of the slab shoe with Cover Mat RCS 70x70 (**43**). (Fig. C4.07)
2. If necessary, nail the cover mat to the foldable cover.



Cover any remaining gaps with suitable means, e.g. Elastomer cover tapes. Make sure that neither the climbing procedure nor the opening of the flaps is impaired in any way.

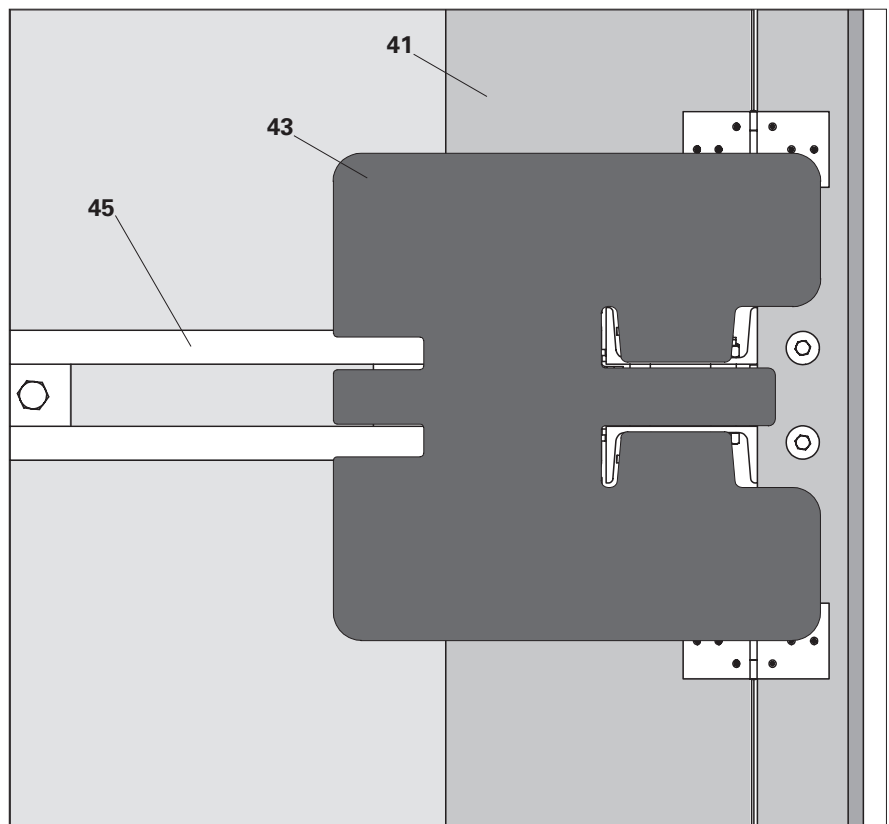

Fig. C4.07

Troubleshooting



Warning

During assembly on the construction site, components may fall to the ground and hit people below! This can lead to serious injuries or even death.
 ⇒ Cordon off danger zones beneath the working areas.

Fault	Cause	Measure
Guiding skids cannot be closed.	<ul style="list-style-type: none"> ■ Climbing rail is not correctly positioned in the guide shoe. 	<ul style="list-style-type: none"> ■ Pull climbing rail inwards with the guide-in tool.
	<ul style="list-style-type: none"> ■ Climbing rail spacing is not correct. 	<ul style="list-style-type: none"> ■ Detach climbing enclosure and adjust spacing of climbing rail.
	<ul style="list-style-type: none"> ■ Slab shoe spacing is not correct. 	<ul style="list-style-type: none"> ■ Slightly loosen the leading tie bolt, close the guiding skids and tighten them using component tolerances. Alternatively: <ul style="list-style-type: none"> ■ Mount new anchoring through the slab with tie rods and wingnut counterplates.
Climbing unit is not lying on the intended spacers on both sides.	<ul style="list-style-type: none"> ■ Climbing rail is resting on a slab shoe that is positioned below. ■ Storey height is approx. a multiple of 50 cm. 	<ul style="list-style-type: none"> ■ Raise the climbing unit by approx. 10 cm using the crane. Deactivate the pawls of all climbing shoes positioned above. Position climbing unit with the intended spacer on the pawl of the bottom climbing shoe.

Fitting the leading tie

With the Slab Tie Gauge RCS 61 (**54**), the leading tie (**47**) is fixed in position during concreting.
Variable length L = 61 to 102 cm.



The stop on the support plate creates an impression in the concrete which is suitable for the slab shoe.

Components

- 1** Enclosure post
- 47** Anchoring
- 53** Bolt ISO 4014 M24 x 70-10.9
- 54** Slab Tie Gauge 61 RCS

Assembly

1. Loosen the screw connections of the clamping plates (**54.4**).
2. Insert the slab tie gauge into the enclosure post.
3. Turn the clamping plates behind the profile of the enclosure post (**1**) and slightly tighten the bolted connection.

Adjusting the length

1. Loosen wing screws (**54.1**).
2. Move telescopic piece (**54.2**) until the support plate (**54.3**) sits flush on the stop end formwork.
3. Place support plate on stop end formwork and fix using nails.

Adjusting the height

1. Slightly loosen the bolted connections of the clamping plates (**54.4**).
2. Push the slab tie gauge on the enclosure post until it is in a horizontal position.
3. Tighten the bolted connection. (tightening torque 120 Nm)
4. Tighten wing screws (**54.1**). (Fig. D1.01 + D1.02)

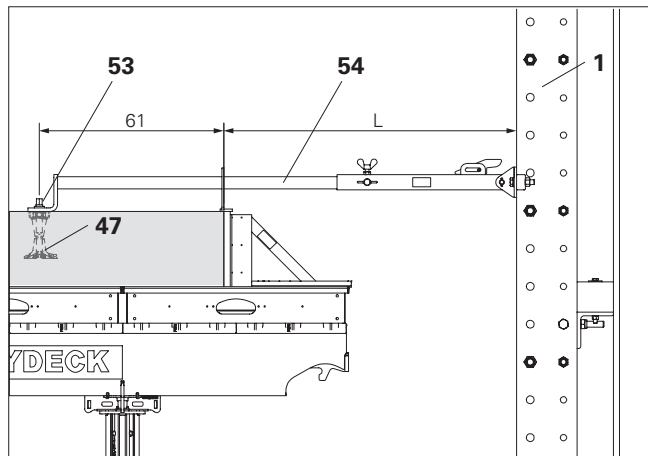

Fig. D1.01

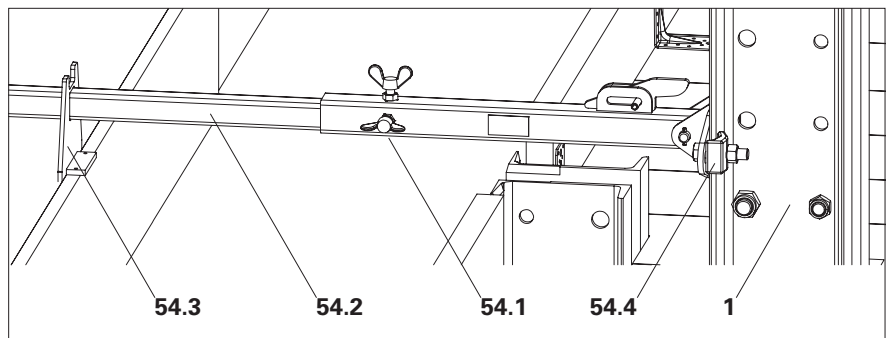

Fig. D1.02

Pivoting downwards

1. Mount the leading tie (**47**) on the slab tie gauge (**54**) using bolts M24 x 70 (**53**).
 2. Press the slab tie gauge lightly against the enclosure post, hold in place and push the locking bar (**54.5**) upwards.
 3. Swivel the slab tie gauge downwards.
 4. Fix the support plate (**54.3**) to the stop end formwork using nails.
- (Fig. D1.03 + D1.03a)

Pivoting upwards



Swivel the slab tie gauge upwards only after the concrete has sufficiently hardened.

1. Remove bolts M 24 x 70 (**53**) from the leading tie.
 2. Pull out nails that have been used to fix the support plate (**54.3**) to the stop end formwork.
 3. Hold the locking bar (**54.5**) up and pivot the slab tie gauge vertically upwards. Drop the locking bar behind the mounting plate. The locking bar (**54.5**) fixes the slab tie gauge in a vertical position.
- (Fig. D1.03b + D1.03)

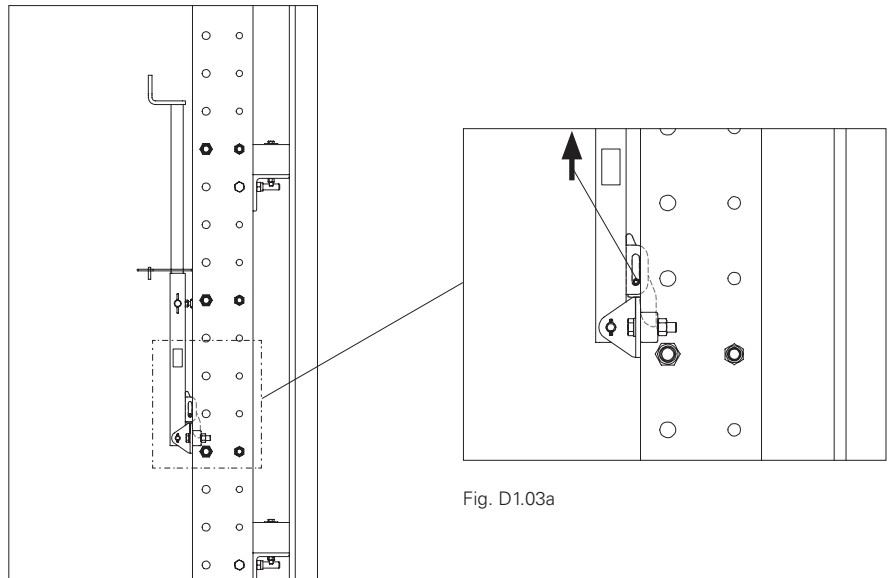

Fig. D1.03

Fig. D1.03a

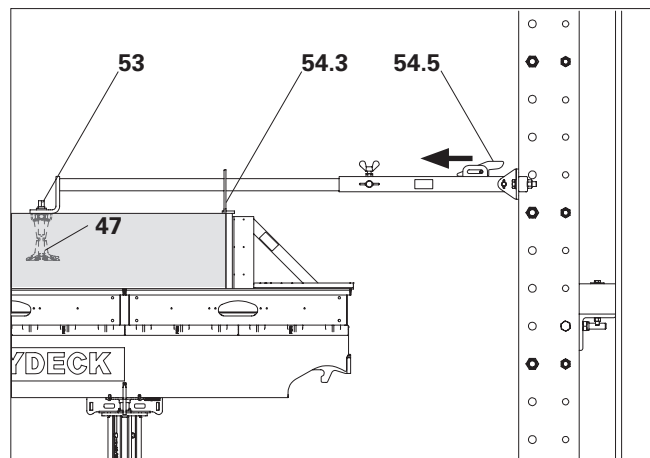

Fig. D1.03b

Fixing the slab tie in the reinforcement



In order to prevent the climbing tie from moving, PERI recommends fixing the tie to the top reinforcement of the slab.

Components

- 47.2** Threaded Anchor Plate DW 20
- 47.5** Climbing Cone-2 M24/DW 15
- 54** Slab Tie Gauge 61 RCS
- 150** Reinforcement

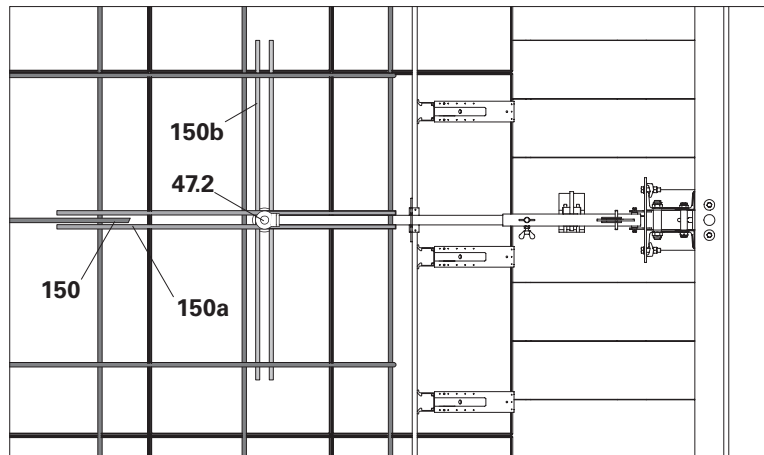

Fig. D1.04

Assembly

1. Create an opening in the reinforcement for the threaded anchor plate (**47.2**). If necessary, move colliding reinforcement bars. For mesh reinforcement, cut rod and replace it with reinforcement bars of the same diameter.
2. Insert two pairs of reinforcement bars crosswise in the top (**150a**) and bottom (**150b**) positions of the top reinforcement.
3. Fold down the slab tie gauge (**54**) and install the climbing cone (**47.5**). Align slab tie gauge and secure.
4. Push the 4 reinforcement bars (**150a + 150b**) all the way up to the climbing cone (**47.5**) so that they touch it on each side. Wire reinforcement bars to the slab reinforcement. (Fig. D1.04 + D1.04a)

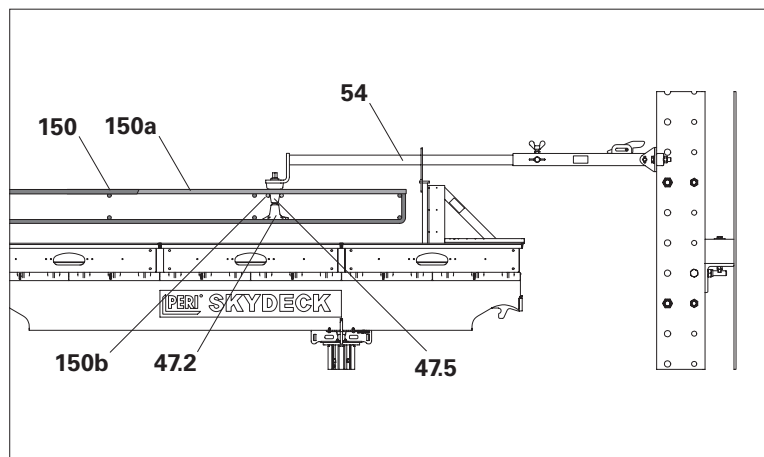

Fig. D1.04a

Mounting the stop end slab tie

Anchoring M30

Stop End Slab Tie M30/25-160
with red advancing cap

Anchoring M24

Stop End Slab Tie M24/20-128
with grey advancing cap

Components

51 Stop End Slab Tie M30/25-160

52 Stop End Slab Tie M24/20-128

Assembly

1. Nail the advancing cap (**51.1**) to the stop end formwork. **1**
 2. Twist stop end slab tie (**51**) onto the thread of the cap. **2**
 3. Wire the stop end slab tie to the slab reinforcement. **3**
- The stop end slab tie is ready.

Striking



Caution

You can get caught on the protruding nails of the advancing cap!
Risk of injury.

- ⇒ Bend over nails immediately after striking.
4. Bend over protruding nails immediately after striking. **4**
 5. Loosen the advancing cap (**51.1**) by turning it counterclockwise and remove. **5**
- The anchoring point is now ready. **6**

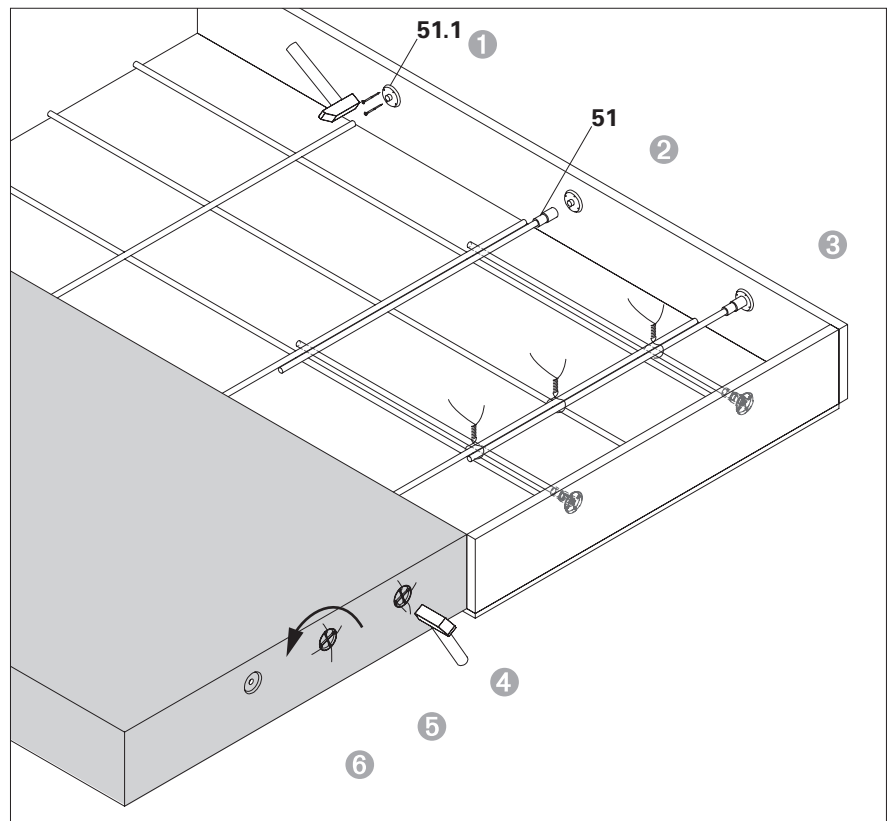

Fig. D1.05

Fitting the suspension



Warning

If not correctly assembled, the slab shoe and climbing shoe can tip over the slab edge, fall to the ground and hit people below!

This can lead to serious injuries or even death.

- ⇒ Cordon off danger zones beneath the working areas.
- ⇒ Loosely screw the slab shoe onto the anchoring (**47**), then position over the slab edge.
- ⇒ Secure climbing shoes against falling to the ground by means of ropes.



Assembly of the slab shoe is usually carried out with protection provided by the climbing enclosure. If this is not possible in exceptional cases or the gap to the enclosure is too large, use personal protective equipment to prevent falls.

Components

- 45** Slab Shoe RCS
 - 47** Anchoring
 - 48** Stop End Slab Shoe RCS
 - 51** Stop End Slab Tie M30/25-160
 - 52** Stop End Slab Tie M24/20-128
 - 53** Bolt ISO 4014 M24 x 70-10.9
 - 49** Bolt ISO 4017 M30 x 70-8.8
 - 151** PERI Tie Bolt 14/20x130
-

Assembly of the Slab Shoe RCS

1. Place the slab shoe (45) on the slab at an angle.
2. Fix to the anchoring (47) using bolts M24 x 70 (53).
3. Turn the slab shoe into the correct position and lower it.
4. Tighten bolt M24x70 (53).
5. Secure the front slot (47.6) to the floor slab using tie bolts (151). Alternatively, secure with suitable heavy-duty dowels or on embedded bolts and long nuts.

(Fig. D1.06 + D1.06a)



According to plan, there is a gap between the slab edge and the stop plate of the slab shoe:

- a = 600 mm,
- b = 100 mm,
- d_x = min. 10 mm.



Have all fixings been correctly tightened?

- Tightening torque of slab shoe M24 = 60 Nm.

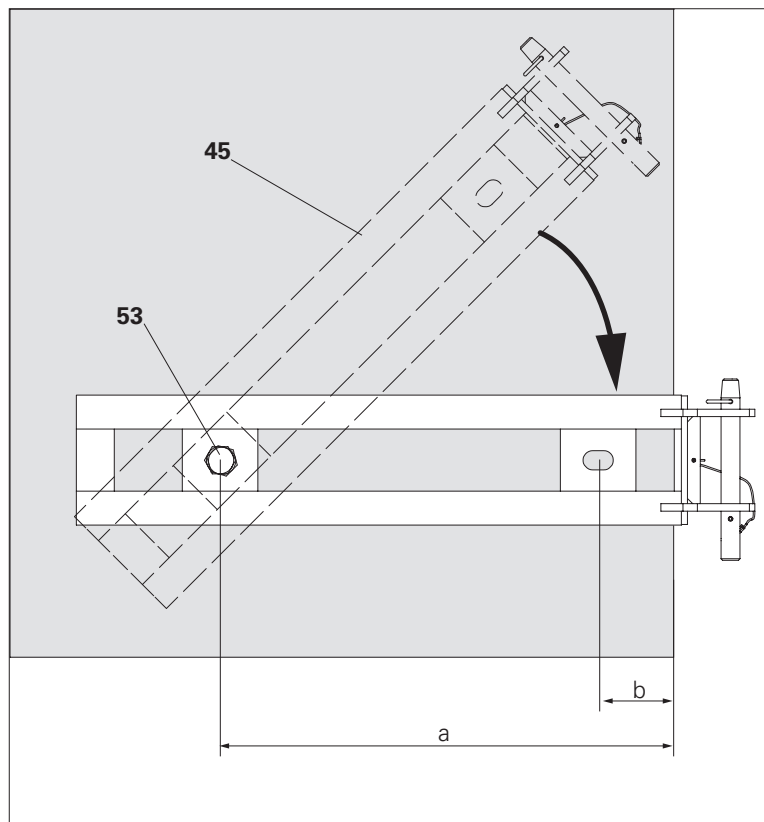

Fig. D1.06

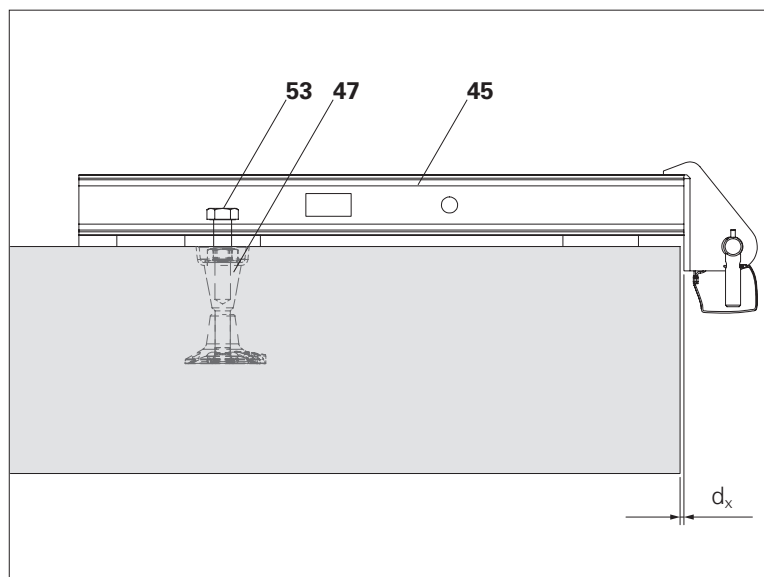

Fig. D1.06a

Assembly of the Stop End Slab Shoe RCS

Components

- 48** Stop End Slab Shoe RCS
- 50** Reducing bushing \varnothing 30 - 25
- 51** Stop End Slab Tie M30/25-160
- 53** Bolt ISO 4014 M24 x 70-10.9
- 49** Bolt ISO 4017 M30 x 70-8.8

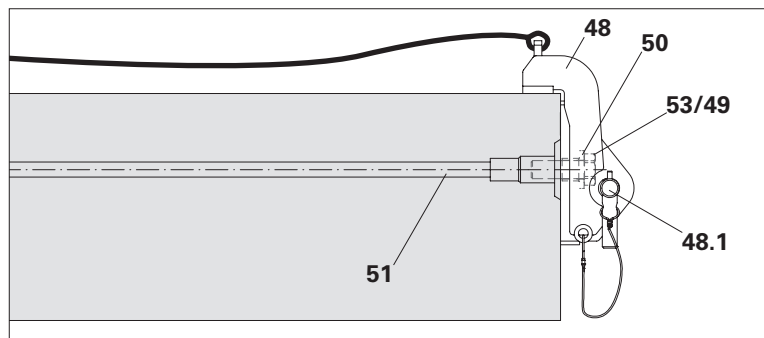

Fig. D1.07

Assembly

1. Secure the stop end slab shoe against falling to the ground, e.g. with a rope.
2. Screw the Stop End Slab Shoe RCS (**48**) onto the Stop End Slab Tie (**51/52**) using bolt M30 x 70 (**49**) or bolt M24 (**53**) with the reducing bushing (**50**).
3. Remove guardrails.
(Fig. D1.07)



Have all fixings been correctly tightened?

- Tightening torque of stop end slab shoe M24 = 100 Nm.
- Tightening torque of stop end slab shoe M30 = 100 Nm.

Assembly of the Climbing Shoe RCS



For operation of the climbing shoe, see Section D2.

Components

- 44** Climbing Shoe RCS
- 44.1** Climbing pawl
- 45** Slab Shoe RCS
- 45.1** Locking pin

Assembly

1. Secure Climbing Shoe RCS (**44**) on the bolt for restraining the climbing device (**44.6**) against falling.
 2. Close the guiding skids.
 3. As a rule, lock the climbing pawl (**44.1**) with the pawl lock (**44.4**).
 4. Insert the climbing shoe into the Slab Shoe RCS (**45**) or the Stop End Slab Shoe RCS.
 5. Insert the locking pin (**45.1**) or (**48.1**) through the lateral cheeks of the wall shoe and climbing shoe and secure with cotter pin.
 6. Open guide skids (**44.2**) on the climbing shoe to allow easier insertion of the climbing rail.
- (Fig. D1.08 + D1.08a)



- Are all locking pins on the guide skids fully inserted and secured?
- Are all locking pins of the slab shoes/ stop end slab shoes secured with cotter pins?

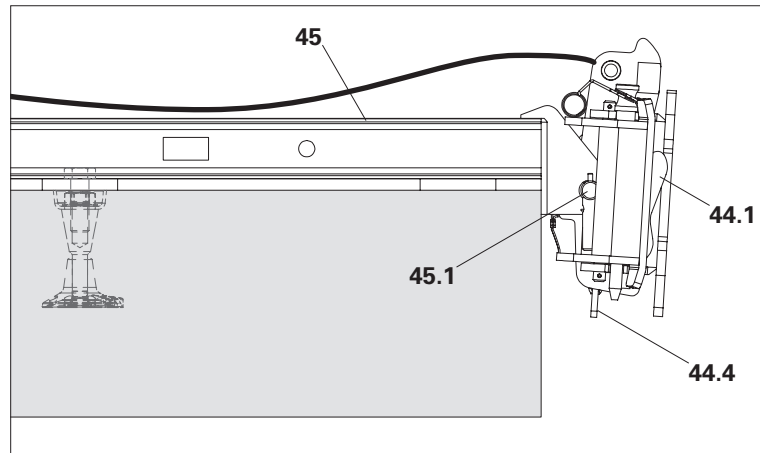

Fig. D1.08

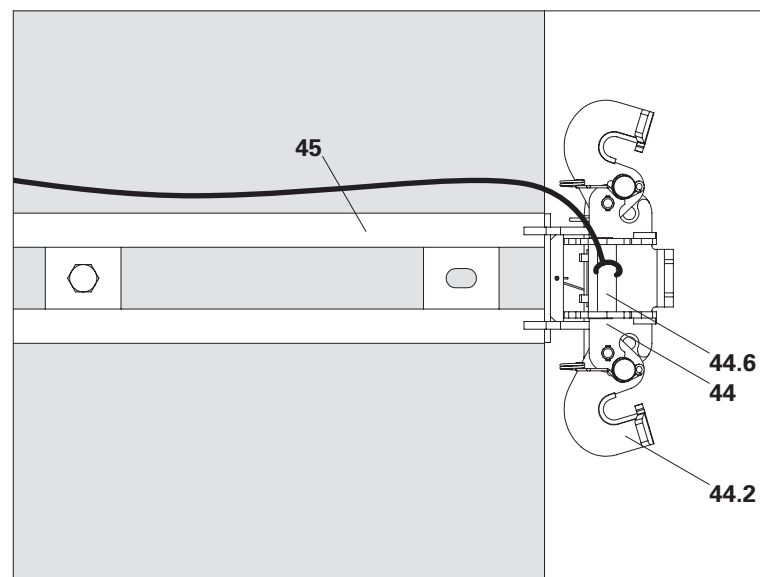

Fig. D1.08a

Bracing of corner elements



Install temporary bracing in the case of expected wind speeds of more than 100 km/h.

Components

2	Climbing Rail RCS
24	Fitting pin \varnothing 21 x 120
26	Cotter pin 4/1
47.6	Tie Rod DW 15, special length
117	Heavy-duty dowel \varnothing 22
118	Heavy-duty dowel \varnothing 30
119	Hex. Nut DW 15 AF 30/50
122	Bracing Shoe RCS DW 15
123	Eye Nut RCS DW 15
125	Articulated Spanner RCS DW 15

Assembly:

1. Screw the tie rod (**47.6**) into the eye nut (**123**). (Fig. D1.09a)
2. Connect the tie rod to the articulated spanner (**125**) by means of Nut DW 15 (**119**).
3. Fit the eye nut (**123**) into the Climbing Rail RCS (**2**) using the fitting pin \varnothing 21 x 120 (**24**) and cotter pin (**26**) whilst standing on the platform.
4. Bolt the articulated spanner (**125**) to the Bracing Shoe RCS DW15 (**122**). (Fig. D1.09b)

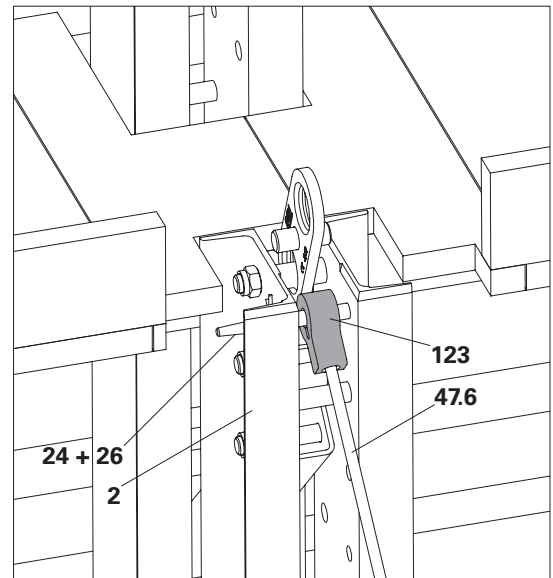

Fig. D1.09a

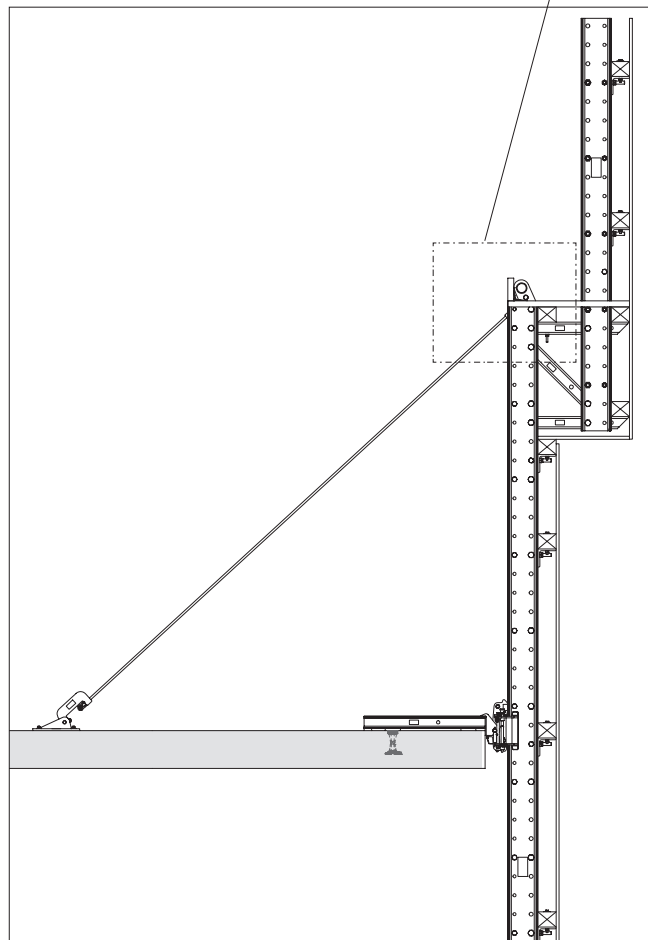

Fig. D1.09

5. Position the bracing shoe on the slab and drill the holes for the heavy-duty dowels in accordance with the plan.
6. Brush and blow out holes according to installation instructions of the dowel manufacturer.
7. Attach the bracing shoe (122) with heavy-duty dowels (117) (4 x Ø 22) or (118) (2 x Ø 30) (Fig. D1.09b - D1.09e).
8. Turn the nut (119) in a clockwise direction in order to pre-tension the bracing.

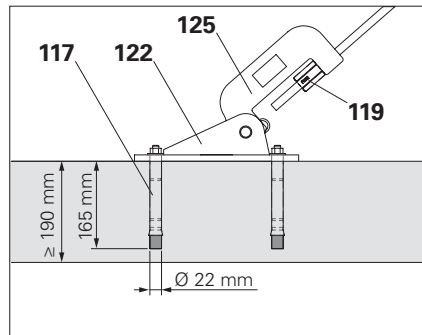

Fig. D1.09b

Storage

Assembled or packaged on the platforms outside of the walkways. Secure bracing to prevent it falling to the ground.

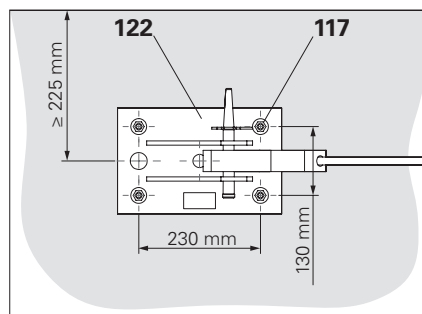

Fig. D1.09c

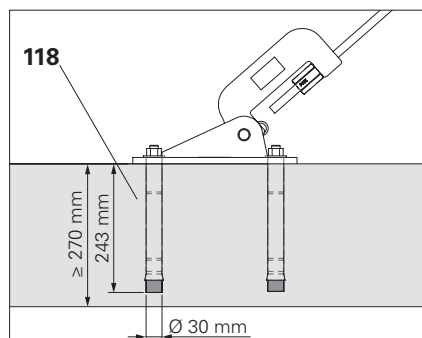

Fig. D1.09d

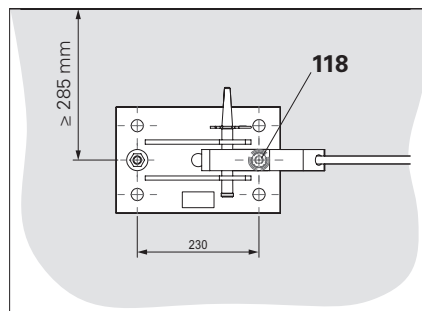

Fig. D1.09e

Horizontal bracing



The horizontal bracing provides necessary anchoring to the building and serves to transfer the acting wind loads during working and storm conditions. During the climbing procedure, the horizontal bracing is to be swivelled up and fixed in position in order to prevent a collision with the building or formwork.

Components

- 1** Enclosure post
- 24** Fitting pin \varnothing 21 x 120
- 25** Fitting pin \varnothing 26 x 120
- 26** Cotter pin 4/1
- 27** Cotter pin 5/1
- 47** Anchoring
- 48** Stop End Slab Shoe RCS
- 53** Bolt ISO 4014 M24 x 70-10.9
- 120** Heavy-Duty Spindle SLS 100/180
- 121** Spindle Shoe SLS/RCS M24
- 124** Forkhead Adapter RCS/SLS

Assembly on the enclosure post:

1. Connect the Spindle Shoe SLS/RCS (**121a**) to the enclosure post (**1**) using one fitting pin \varnothing 26 mm (**25**) and one fitting pin \varnothing 21 mm (**24**). Secure both fitting pins with cotter pins (**26 + 27**). Angle of inclination $\alpha = 10 \pm 5^\circ$
2. Connect Heavy-Duty Spindle SLS 100/180 (**120**) to the spindle shoe (**121a**) using fitting pin \varnothing 21 mm (**24**) and cotter pin (**26**).
3. Attach a second spindle shoe (**121b**) to the heavy-duty spindle (**120**) using fitting pin \varnothing 21 and cotter pin (**26**). (Fig. D1.10)

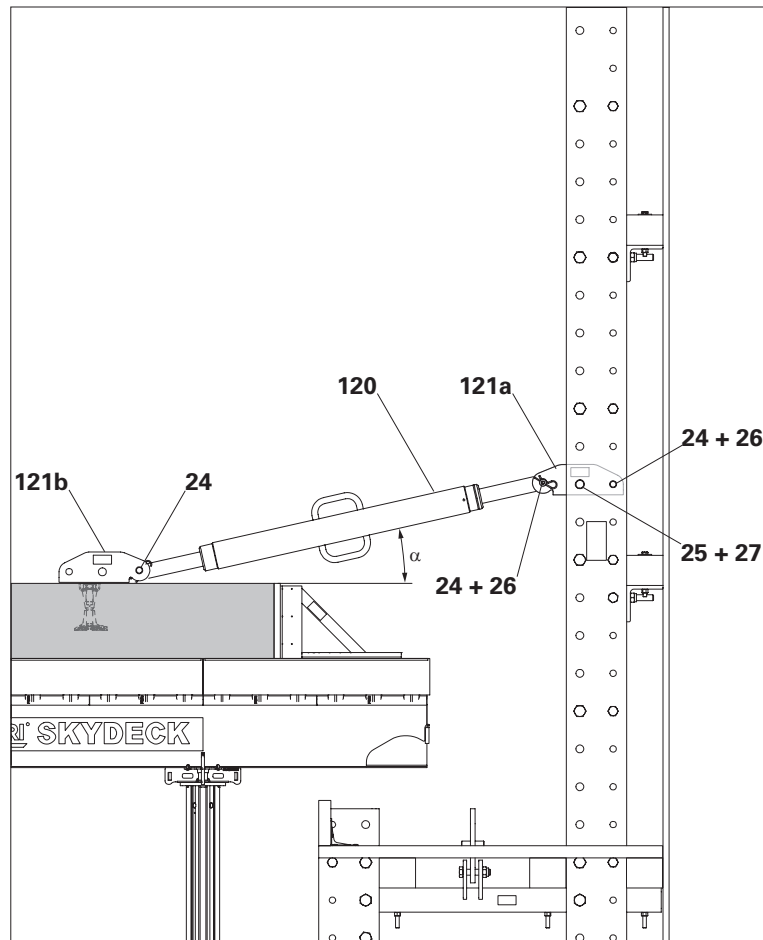

Fig. D1.10



Are all bolts secured with cotter pins?

Anchoring position A:

Heavy-duty spindle in climbing position:

1. Remove fitting pin \varnothing 21 mm (24) in the spindle shoe (121b) and store in hole of the climbing rail.
2. Swivel down the heavy-duty spindle (120) with spindle shoe.

Assembly on the anchoring:

3. Adjust the heavy-duty spindle so that the position of the hole in the spindle shoe corresponds to the anchoring (47).
4. Connect the spindle shoe (121b) to the anchoring using bolt M24 x 70 (53).



Are all bolts secured with cotter pins?

Climbing position B:

Heavy-duty spindle in the anchoring position:

1. Remove bolts M24 x 70 (53) from the anchoring (47).
2. Swivel up the heavy-duty spindle (120) with the spindle shoe.
3. Fix the spindle shoe (121b) in the hole \varnothing 26 of the enclosure post (1) using fitting pins \varnothing 21.

(Fig. D1.10a)



Are all bolts secured with cotter pins?

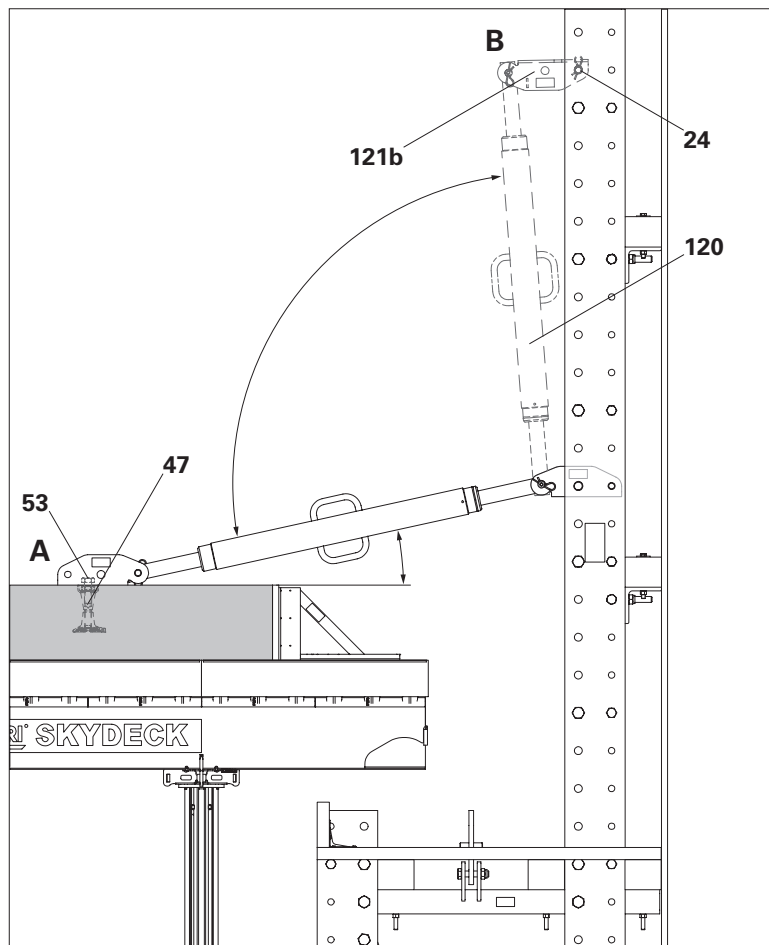

Fig. D1.10a

Assembly on the stop end slab shoe

1. Mount the forkhead adapter (**124**) on the building side of the heavy-duty spindle (**120**) using the bolt and nut provided. (Fig. D1.11)
2. Connect the Spindle Shoe SLS/RCS (**121a**) to the enclosure post (**1**) using one fitting pin \varnothing 26 mm (**25**) and one fitting pin \varnothing 21 mm (**24**). Secure both fitting pins with cotter pins (**26 + 27**).
3. Connect the heavy-duty spindle (**120**) to the spindle shoe (**121a**) using the fitting pin \varnothing 21 mm (**24**) and cotter pin (**26**).

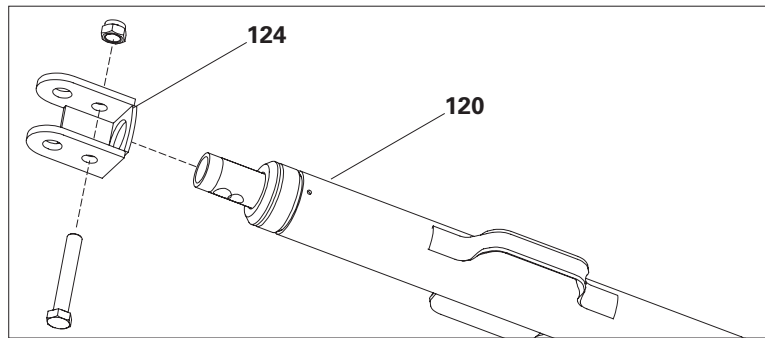

Fig. D1.11

Anchoring position A:

4. Connect the heavy-duty spindle with attached forkhead adapter (**124**) to the Stop End Slab Shoe RCS (**48**) using bolts \varnothing 25 (**48.1**).

Climbing position B:

3. Fix heavy-duty spindle to the enclosure post using binding wire.
- (Fig. D1.11a)



Are all bolts secured with cotter pins?

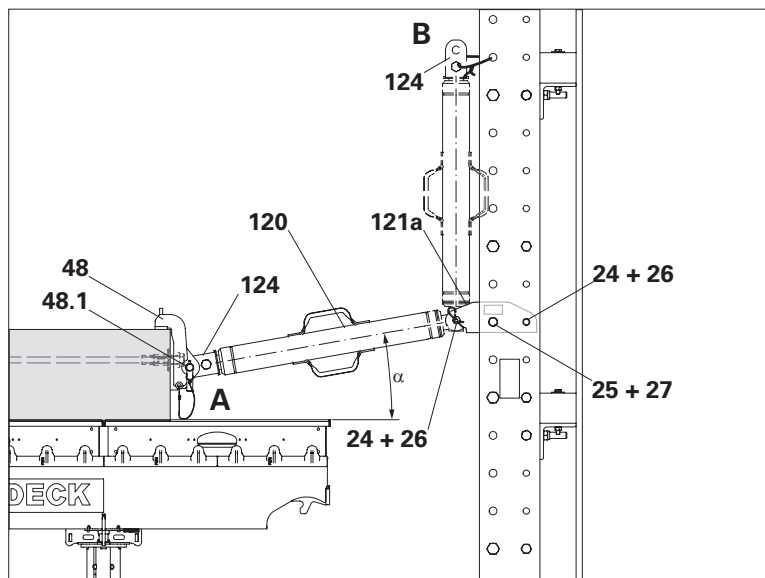

Fig. D1.11a

Dismantling the suspension



Warning

- There is a risk of falling from unsecured slab edges!
A fall can result in serious injury or even death.
 - ⇒ Guardrails should be installed prior to climbing.
 - ⇒ Use personal protective equipment to prevent falling from a height.
- If not correctly disassembled, the slab shoe and climbing shoe can tip over the slab edge, fall to the ground and hit people below!
This can lead to serious injuries or even death.
 - ⇒ Cordon off danger zones beneath the working areas.
 - ⇒ First loosen the anchoring **(47)** slightly and turn the slab shoe to a secure position.



If possible, install guardrails on the slab edge before dismantling the slab shoe. Complete the toe board after disassembling the slab shoe.

Components

- 44** Climbing Shoe RCS
 - 44.1** Climbing pawl
 - 45** Slab Shoe RCS
 - 45.1** Locking pin
 - 53** Bolt ISO 4014 M24 x 70-10.9
-

Dismantling

1. Secure Climbing Shoe RCS (**44**) on the bolt for restraining the climbing device (**44.6**) against falling.
2. Hold the climbing shoe against the bolt (**44.6**), pull out locking pin (**45.1**) of the slab shoe.
3. Pull the climbing shoe upwards and lay on floor slab; then insert locking pin (**45.1**) into the slab shoe again. (Fig. D1.12)
4. Loosen bolt M24 x 70 (**53**) approx. 15 mm, but do not remove. (Fig. D1.12a)
5. Lift Slab Shoe RCS (**45**) and turn it inwards to a secure position.
6. Remove bolt M24 x 70. (Fig. D1.12b)

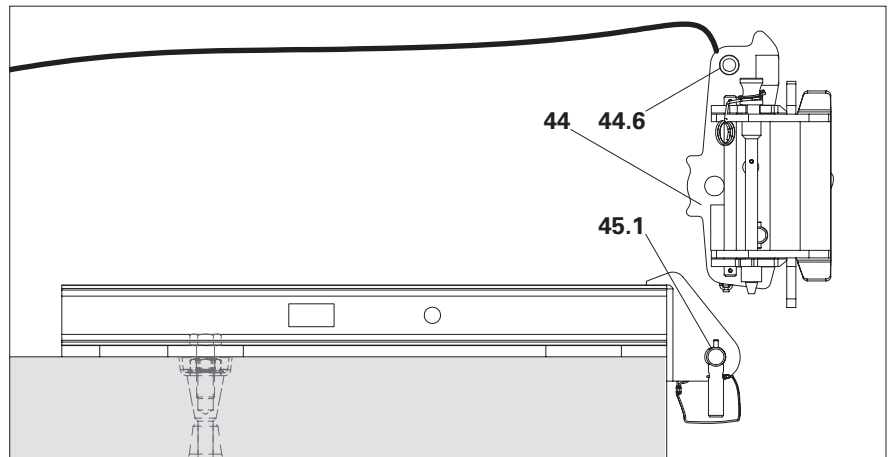

Fig. D1.12

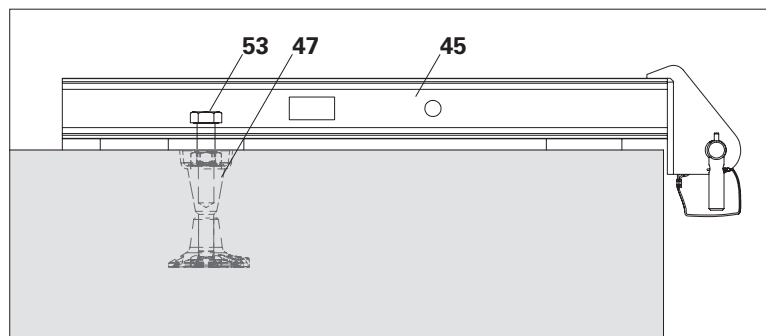

Fig. D1.12a

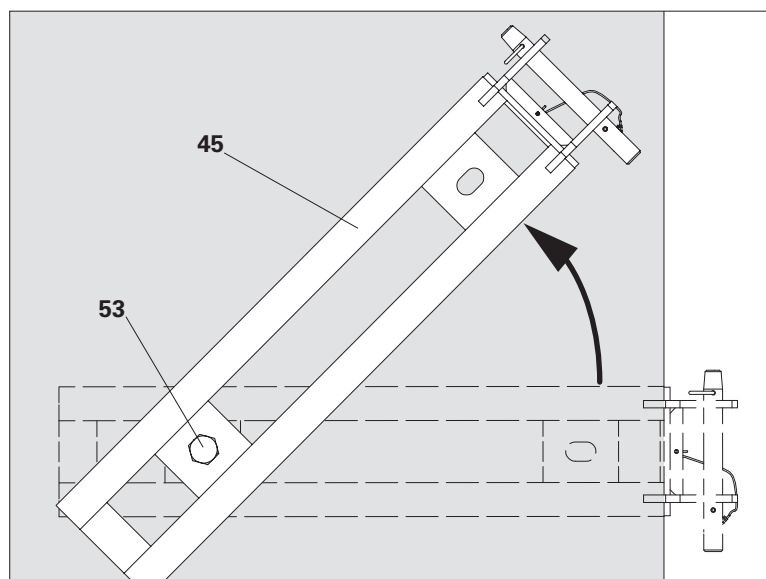

Fig. D1.12b

Removing the anchoring



Warning

There is a risk of falling from unsecured slab edges!

A fall can result in serious injury or even death.

- ⇒ Guardrails should be installed prior to climbing.
- ⇒ Use personal protective equipment to prevent falling from a height.



- Work to be carried out with site personnel protected by guardrails that follow the climbing protection panel.
- For fixing the concrete cones, observe the separate Instructions for Use!

Components

47.1 Screw-On Cone-2 M24/DW 20

47.7 Threaded Anchor Plate DW 15
Ø 80 mm

47.9 KK Concrete Cone M24

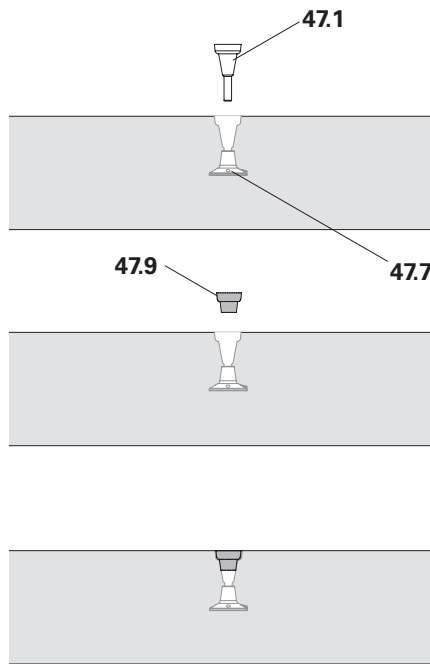

Fig. D1.13a

Anchoring M24 Variant 1

Screw-On Cone M24/DW 20 (**47.1**)
partially re-usable.

Dismantling

1. Release the screw-on cone with socket wrench AF 36 and remove.
2. Close remaining hole with suitable KK Concrete Cone (**47.9**) and matching adhesive.

(Fig. D1.13a)

Anchoring M24 Variant 2

Climbing Cone-2 M24/DW 15 (47.5)
partially re-usable.

Components

47.5 Climbing Cone-2 M24/DW 15

47.7 Threaded Anchor Plate DW 15
Ø 80 mm

47.9 KK Concrete Cone M24

Dismantling

1. Release the climbing cone with socket wrench AF 36 and remove.
2. Close remaining hole with suitable KK Concrete Cone (47.9) and matching adhesive.
(Fig. D1.13b)

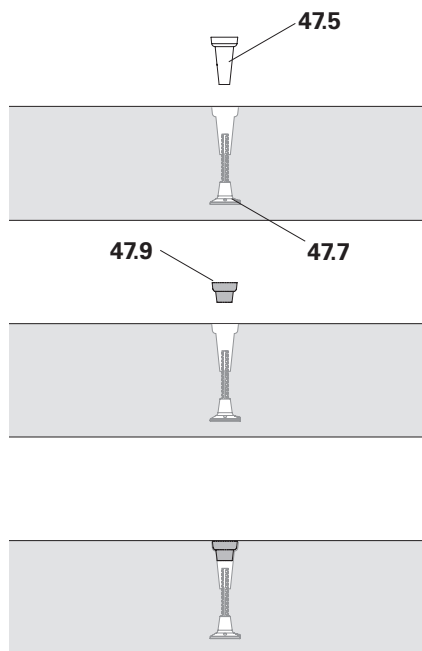

Fig. D1.13b



Warning

During dismantling, anchoring components may fall to the ground and hit people below!

This can lead to serious injuries or even death.

⇒ Cordon off danger zones beneath the working areas.

⇒ In order to prevent personnel falling out of the building, install anti-fall protection with a dense mesh underneath, e.g. PROKIT.

Anchoring M24 Variant 3

Climbing Cone-2 M24/DW 15 completely re-usable.

Components

47.5 Climbing Cone-2 M24/DW 15

47.7 Threaded Anchor Plate DW 15
Ø 80 mm

47.9 KK Concrete Cone M24

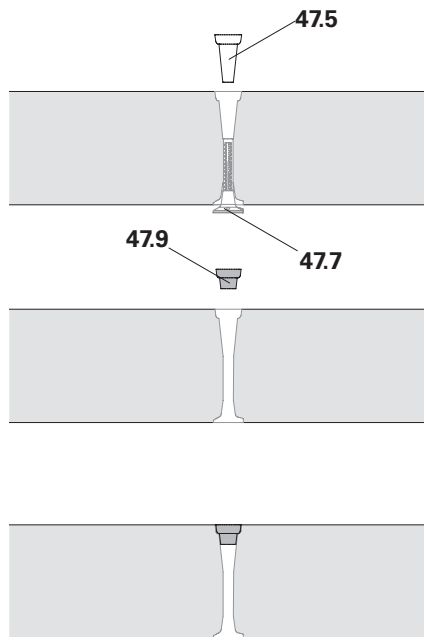

Fig. D1.13c

Dismantling

1. Loosen climbing cone (**47.5**) using a Socket Wrench AF36 and unscrew approx. 1 cm.
2. Hammer the cone downwards so that the Threaded Anchor Plate DW 15 (**47.7**) is loosened.
3. Now completely remove the cone. Remove the threaded anchor plate together with Tie Rod DW 15 from below using a secured mobile scaffold.
4. Close remaining hole with suitable KK Concrete Cone (**47.9**) and matching adhesive.

(Fig. D1.13c)

Opening and closing the climbing shoe

The safety pins (44.3) hold the guiding skids (44.2) in a closed position. (Fig. D2.01 + D2.01a)

Components

- 44 Climbing Shoe RCS
- 44.1 Climbing pawl
- 44.2 Guiding skids
- 44.3 Safety pins
- 44.6 Spring lock

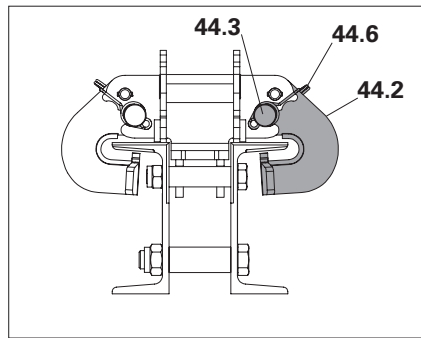

Fig. D2.01

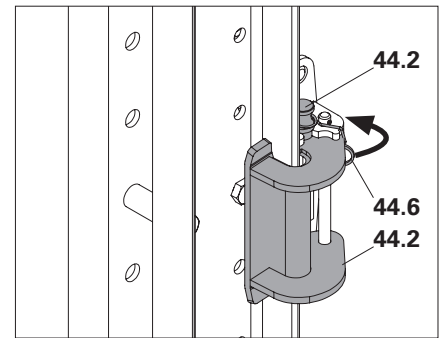

Fig. D2.01a

Opening the climbing shoe:

1. Release the locking spring (44.6). For this, pull out the ring under the guiding skid (44.2). (Fig. D1.01 + D1.01a)
2. Lift safety pin (44.3).
3. Fold up guiding skids (44.2). (Fig. D1.02 + D1.02a)
4. Re-insert safety pins (44.3) in the opened position; place the locking spring (44.6) only loosely on the folding runner. (Fig. D1.03 + D1.03a)
5. Proceed in the same way with the other guiding skid. (not shown)

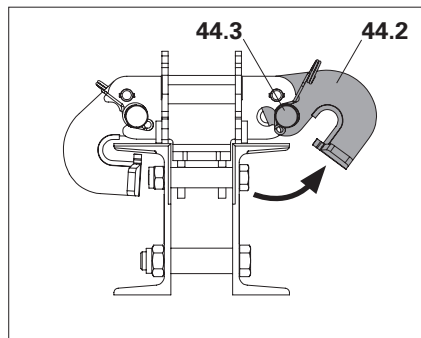

Fig. D2.02

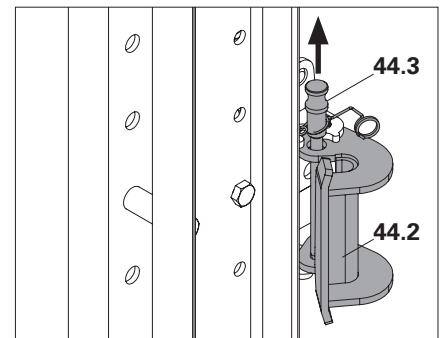

Fig. D2.02a



Opening the guiding skids facilitates the process of inserting the climbing rail during climbing and allows the climbing rail to be inserted during initial assembly.



Danger

Do not open the guiding skids of any Climbing Shoe that is under load / supporting the Rail.

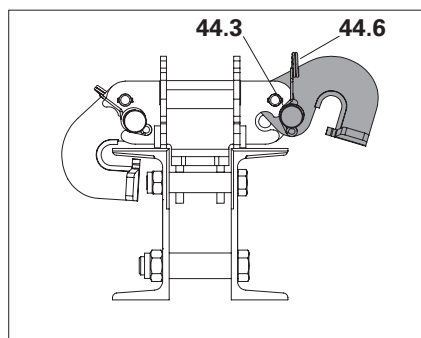

Fig. D2.03

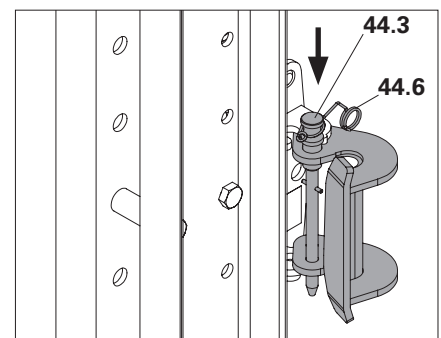

Fig. D2.03a

D2 Operating the climbing shoe

Closing the climbing shoe:

1. Lift safety pin (44.3). (Fig. D2.04 + D2.04a)
2. Fold guiding skid (44.2) forwards. (Fig. D2.05 + D2.05a)
3. Reinsert the locking bolt (44.3) completely in the closed position.
4. Fix the locking spring in place (44.6). For this, the ring is snapped into place under the guiding skid (44.2).
5. Proceed in the same way with the other guiding skid.



Are both locking pins completely inserted and is the locking spring fixed in position?

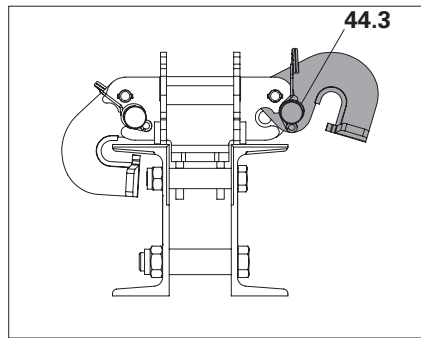

Fig. D2.04

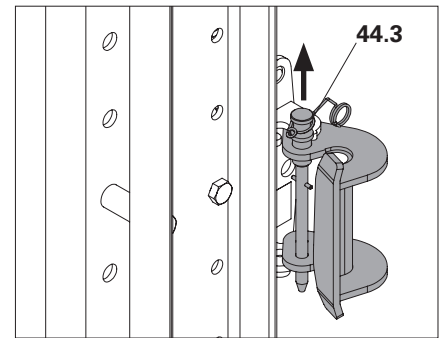

Fig. D2.04a

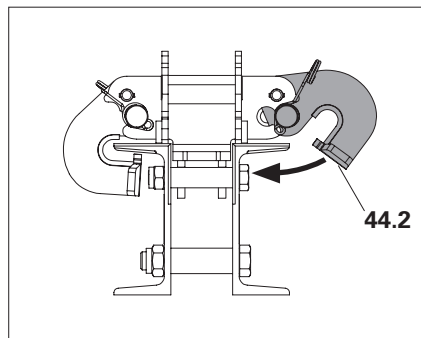

Fig. D2.05

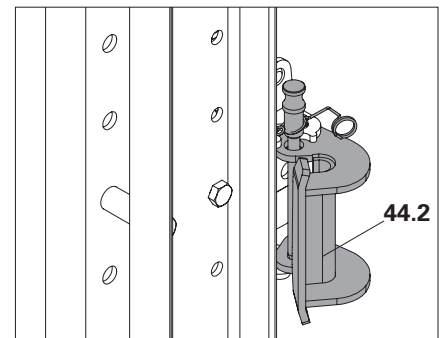

Fig. D2.05a

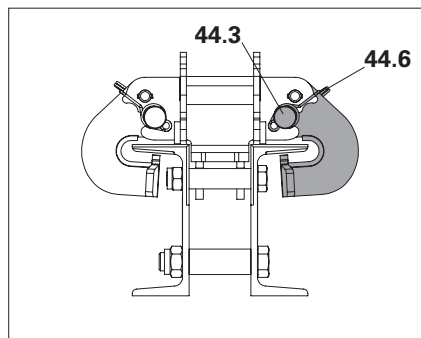

Fig. D2.06

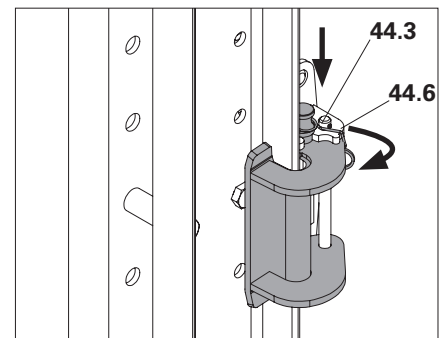

Fig. D2.06a

Activating and deactivating the climbing pawl



Warning

Hands can become trapped between climbing rails and climbing shoes! This can result in serious injuries.

- ⇒ Only activate or deactivate the climbing pawl when the climbing unit has stopped moving.
- ⇒ Do not reach into the climbing rail during the climbing procedure.

Deactivating the climbing pawl

Components

44	Climbing Shoe RCS
44.1	Climbing pawl
44.4	Pawl lock
44.5	Hinged clamp

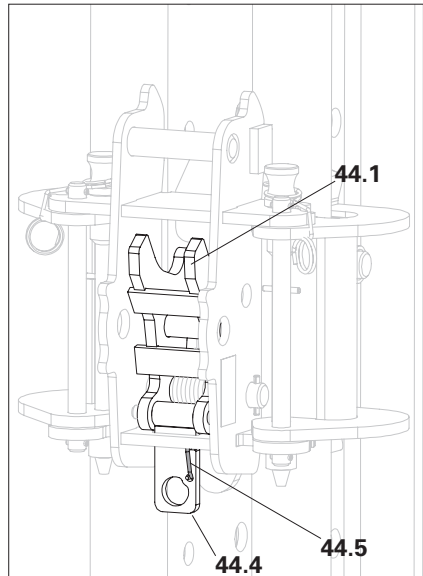

Fig. D2.07

1. Ensure that the climbing unit is stationary.
 2. Pull down the pawl lock (**44.4**) on the climbing shoe.
 3. Fold up the hinged clamp (**44.5**) on the pawl lock and then let go of the pawl lock.
 - The hinged clamp is then clamped and blocks the pawl lock.
 - The climbing pawl (**44.1**) is deactivated and therefore non-operational.
- (Fig. D2.07 + D2.07a)



In this position, no vertical forces from the climbing rail can be transferred via this particular shoe.

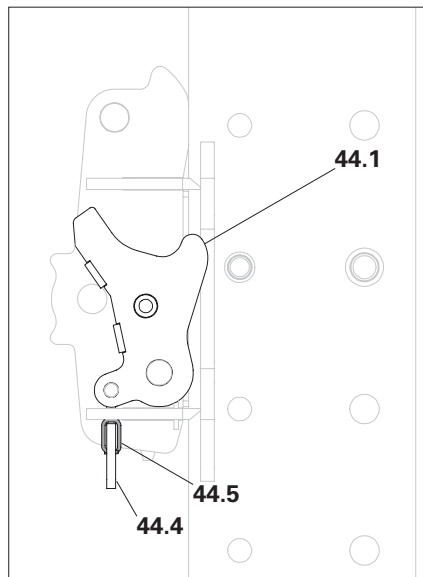

Fig. D2.07a

Activating the climbing pawl

Components

- 44** Climbing Shoe RCS
- 44.1** Climbing pawl
- 44.4** Pawl lock
- 44.5** Hinged clamp

1. Ensure that the climbing unit is stationary.
 2. Pull down the pawl lock (**44.4**) on the climbing shoe.
 3. Fold down the hinged clamp (**44.5**) on the pawl lock and then let go of the pawl lock.
 - The climbing pawl (**44.1**) jumps into its working position.
 - The climbing pawl is activated and therefore operational.
- (Fig. D2.08 + D2.08a)

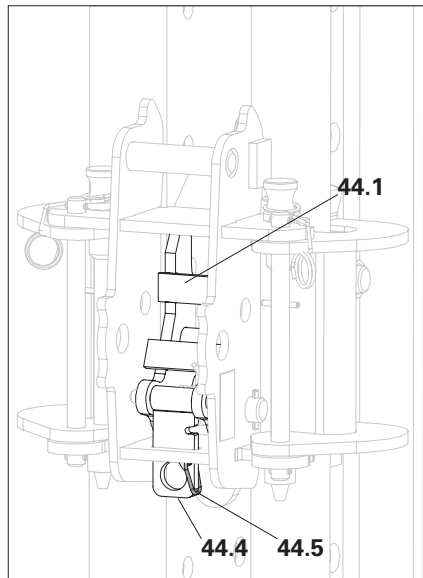

Fig. D2.08



Can the climbing pawl move freely?
Is the hinged clamp hanging downwards?



- This position serves the purpose of transferring vertical forces from the climbing rail during working operations and climbing.
- For storey heights that are dividable by 50 cm, only activate the pawls on the climbing shoes that serve as the planned vertical support. Deactivate all other climbing shoes.

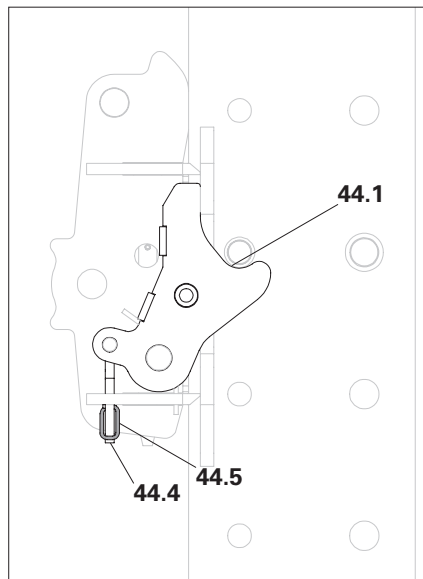

Fig. D2.08a

D2 Operating the climbing shoe (With Climbing Shoe Display RCS)

Activating and deactivating the climbing pawl

Warning

Hands can become trapped between climbing rails and climbing shoes! This can result in serious injuries.

- ⇒ Only activate or deactivate the climbing pawl when the climbing unit has stopped moving.
- ⇒ Do not reach into the climbing rail during the climbing procedure.

Components

- 44** Climbing Shoe RCS
- 44.1** Climbing pawl
- 44.9** Climbing Shoe Display RCS

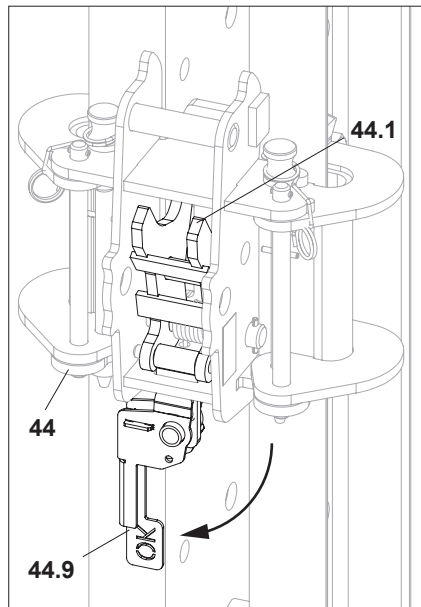

Fig. D2.09

Deactivating the climbing pawl

1. Ensure that the climbing unit is stationary.
2. Swing the Climbing Shoe Display RCS (**44.9**) on the Climbing Shoe RCS (**44**) downwards until it engages in a vertical position.
 - The climbing pawl (**44.1**) is deactivated and therefore non-operational.

(Fig. D2.09 + D2.09a)



- In this position, no vertical forces from the climbing rail or from the drive rail can be transferred via this particular shoe.
- Deactivating the climbing pawl prevents unintentional engagement with the pins of the climbing rail.

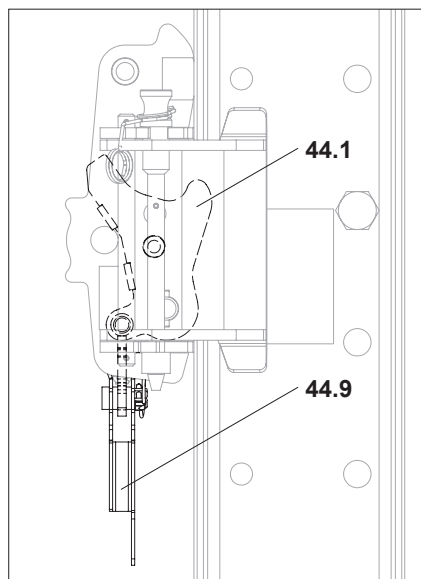

Fig. D2.09a

D2 Operating the climbing shoe (With Climbing Shoe Display RCS)

Activating the climbing pawl

1. Ensure that the climbing unit is stationary.
2. Swing the Climbing Shoe Display RCS (44.9) on the Climbing Shoe RCS (44) upwards.
→ The climbing pawl (44.1) is activated and therefore operational.
(Fig. D2.10 + D2.10a)



- Can the climbing pawl (44.1) move freely?
- Is the Climbing Shoe Display RCS (44.9) suspended horizontally?



This position serves the purpose of transferring vertical forces from the climbing rail during working operations and climbing.

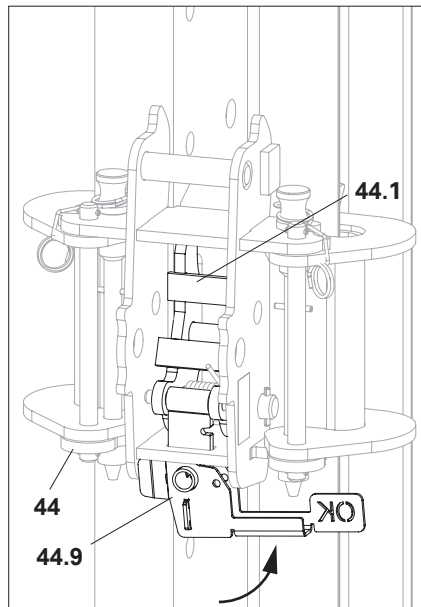

Fig. D2.10

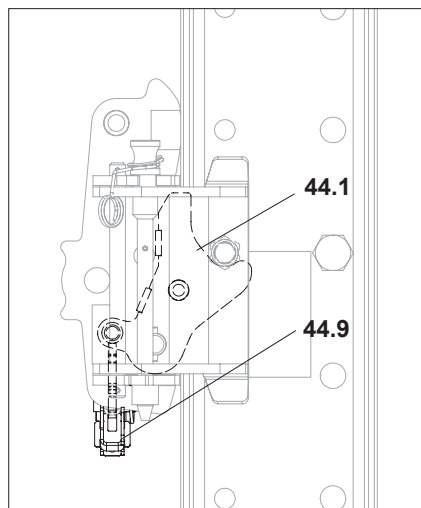

Fig. D2.10a

Safety instructions



Warning

- There is a risk of falling from unsecured slab edges!
 - As a result of the relocation procedure, falling edges are formed between the platforms!
- A fall can result in serious injury or even death.
- ⇒ Guardrails should be installed prior to climbing.
 - ⇒ Areas of risk are to be cordoned off.
 - ⇒ Use personal protective equipment to prevent falling from a height.



Warning

- Body parts can become trapped between climbing rails and slab shoes! This can result in serious injuries.
- ⇒ Do not take hold of anything between the rail guidance shoes and climbing rails while the climbing enclosure is moving.



- The load-bearing capacity of the structural elements, which carry the load-carrying slab shoes, must be ensured!
- Do not transport persons, building materials or tools when moving with the crane. These could fall off, leading to serious injury or even death.
- Materials or other components must not protrude beyond the slab edge. These could hinder the climbing process or fall off.
- In the event of a malfunction, the climbing unit is to be set down in the next possible position and an authorised person is to be informed immediately!
- When climbing by crane, always provide safe access for attaching and detaching the crane lifting gear. Additional two-sling lifting gear that remains on the climbing enclosure may be necessary until it can be safely removed.

Preparations

Components

- 41** Foldable cover (multi-layer plywood sheeting)
- 44** Climbing Shoe RCS
- 85** Guardrail

Assembly

1. Mount the top slab shoes and climbing shoes (**44a**) on the next floor slab. Open the guiding skids on the top climbing shoe (**44a**), deactivate the climbing pawl.
2. Activate the climbing pawls on the middle slab shoe (**44b**). The load is still carried on the bottom slab shoe (**44c**).
3. Remove temporary connections between the climbing units.
4. Dismantle formwork in the area of the slab edge.
5. Mount trailing guardrails (**85**).
6. Fold up foldable covers (**41**) and secure.
7. From a safe position, attach crane lifting gear to Lifting Eye BR-2 2.5 t.
8. Leave the climbing enclosure and danger zone.

(Fig. D3.01)

For operating the climbing shoes, see Section "Opening and closing the climbing shoe" on Page 120 as well as the Section "Activating and deactivating the climbing pawl" on Page 122.

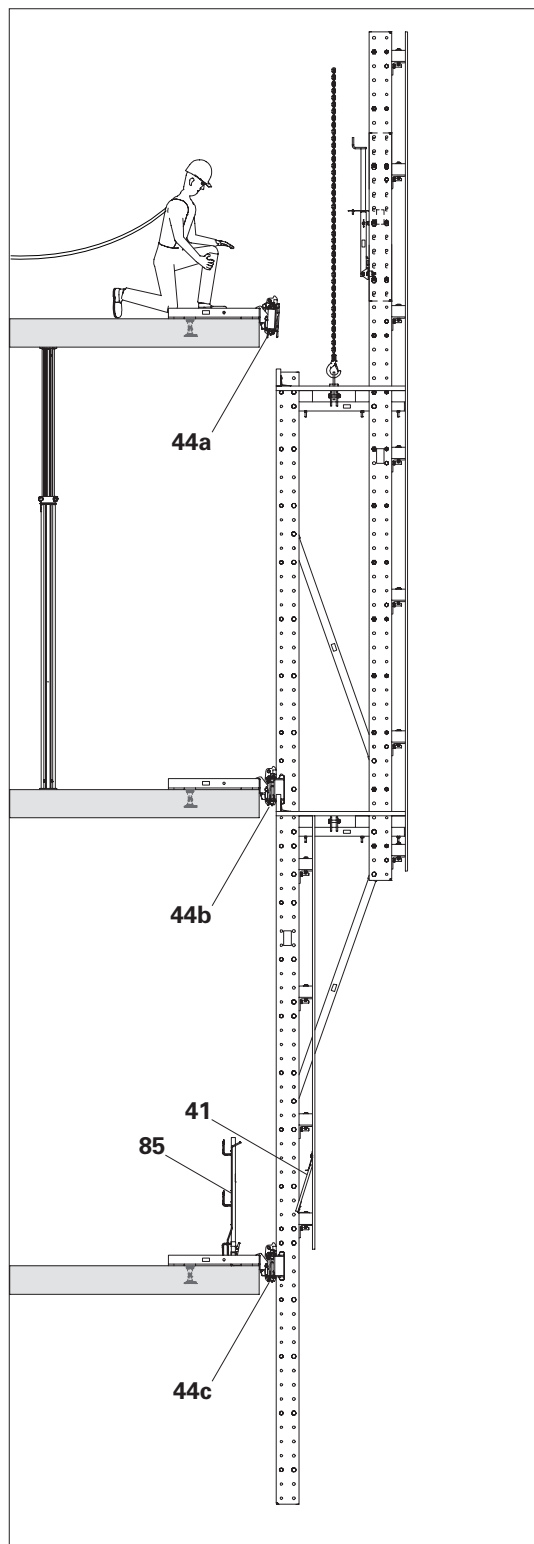

Fig. D3.01

Moving procedure

Components

44 Climbing Shoe RCS

126 Guide-In Tool RCS

1. Raise the climbing unit to the top climbing shoes (**44a**) using the crane; not necessary with Variant 4.
2. Insert the climbing rail (**2**) into the top climbing shoes (**44a**) using the guide-in tool (**126**).
3. Close the guiding skids of the top slab shoe. Climbing pawl remains deactivated. (Fig. D4.03a)
4. If necessary, deactivate the pawls of the bottom slab shoe (**44c**).
5. Raise the climbing unit up to the planned end position until the climbing pawls of the middle slab shoe (**44b**) engage.
6. Lower the climbing unit until the spacers are fully load-bearing on the climbing pawls of the middle slab shoe (**44b**). (Fig. D3.02)

If climbed too far

1. Raise the climbing unit by approx. 10 cm using the crane.
2. Deactivate all pawls of the climbing shoes of this climbing unit. See Section "Activating and deactivating the climbing pawl" on Page 122.
3. Lower the climbing unit until the correct spacer is approx. 10 cm above the pawl of the load-bearing slab shoe (**44b**).
4. Activate the pawl of the load-bearing slab shoe (**44b**).
5. Position the climbing unit on the spacer.

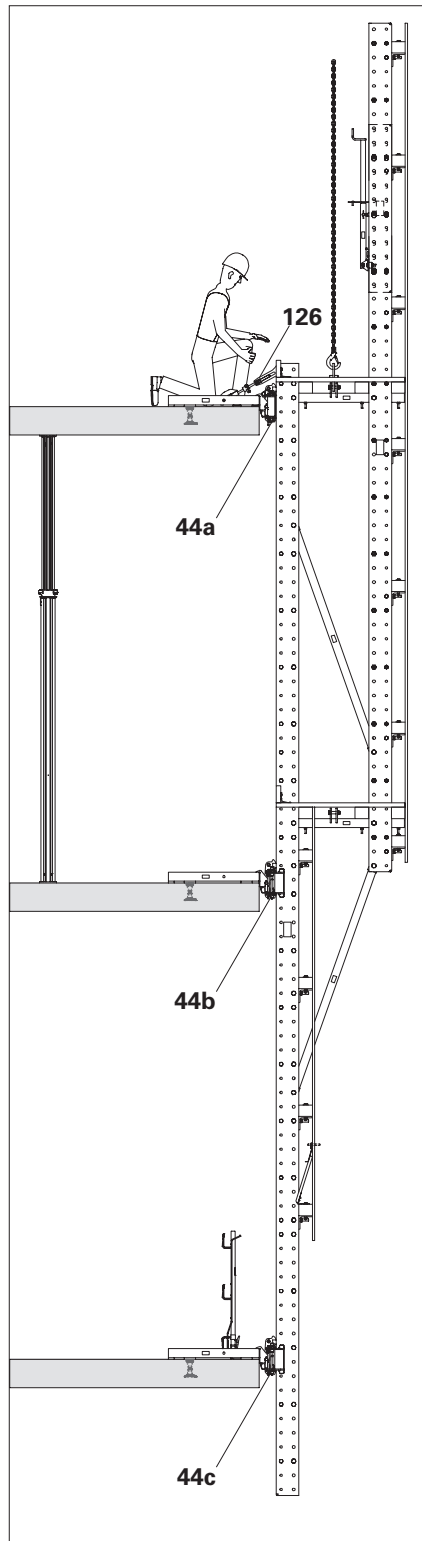

Fig. D3.02

Troubleshooting

Fault	Cause	Measure
Guiding skids cannot be closed.	<ul style="list-style-type: none"> ■ Climbing rail is not correctly positioned in the guide shoe. 	<ul style="list-style-type: none"> ■ Pull climbing rail inwards with the guide-in tool.
	<ul style="list-style-type: none"> ■ Slab shoe spacing is not correct. 	<ul style="list-style-type: none"> ■ Slightly loosen the leading tie bolt, close the guiding skids and tighten them using component tolerances. Alternatively: ■ Mount new anchoring through the slab with tie rods and wingnut counterplates.
Climbing unit is not lying on the intended spacers on both sides.	<ul style="list-style-type: none"> ■ Climbing rail is resting on a slab shoe that is positioned below. ■ Storey height is approx. a multiple of 50 cm. 	<ul style="list-style-type: none"> ■ Raise the climbing unit by approx. 10 cm using the crane. Deactivate the pawls of all climbing shoes positioned above. Position climbing unit with the intended spacer on the pawl of the bottom climbing shoe.

Concluding work

1. Detach the crane lifting gear from a safe position, e.g. mobile scaffold. Alternatively, leave two-sling lifting gear attached to the climbing enclosure until it can be safely dismantled.
2. Complete the guardrails.
3. Dismantle the trailing slab shoe, see Section "Dismantling the suspension" on page 115.
4. Remove anchoring that is no longer needed, see Section "Dismantling the anchoring" on page 117.

Safety instructions



Warning

- There is a risk of falling from unsecured slab edges!
 - As a result of the relocation procedure, falling edges are formed between the platforms!
- A fall can result in serious injury or even death.
- ⇒ Guardrails should be installed prior to climbing.
 - ⇒ Areas of risk are to be cordoned off.
 - ⇒ Use personal protective equipment to prevent falling from a height.
 - ⇒ Keep foldable covers closed after assembling the climbing hydraulics.



Warning

- Body parts can become trapped between climbing rails and slab shoes! This can result in serious injuries.
- ⇒ Do not hold the climbing shoe and climbing rails when the climbing unit is being moved.



- The load-bearing capacity of the structural elements, which carry the load-carrying slab shoes, must be ensured!
- Do not transport persons, building materials or tools when moving with the crane. These could fall off, leading to serious injury or even death.
- Materials or other components must not protrude beyond the slab edge. These could hinder the climbing process or fall off.
- If manual intervention is necessary during the climbing procedure, the platforms to be climbed may only be accessed after consultation with the operating personnel.
- In the event of a malfunction, the climbing enclosure is to be set down in the next possible position and an authorised person is to be informed immediately!
- Arrange the hydraulic hoses in such a way that
 - loops and knots are prevented,
 - no loops form beyond the slab edge,
 - they do not get caught on the climbing platforms.
- Up to 2 units can be climbed at the same time.

Significant differences between Variants 1 - 3 and 4

With Variant 1 - 3, the climbing rail is pulled into the top slab shoe during the climbing procedure.

With Variant 4, the slab shoe must be swivelled into the projecting climbing rail before climbing begins, then anchored and closed.

Initial operation of the climbing hydraulics

See "Instructions for Use for the RCS Climbing Device and Hydraulics"

Preparations

The self-climbing procedure takes place from the slab level with the middle slab shoe.

Carry out preparatory work as described in Section "Preparations" on page 125; however, the foldable covers remain closed at this level until the climbing unit has been mounted!

Additionally:

1. Prepare the climbing hydraulics. See "Instructions for Use for the RCS Climbing Device and Hydraulics"
2. Ensure that the hydraulic unit is available.
3. Lay out hydraulic hoses on the slab without any loops or entanglement.
4. Prepare Climbing Devices RCS 50.

Hydraulic diagram

See Fig. D4.01.

The arrangement of the plug connectors and bushings of the quick couplers is clearly shown.

Remedial measures for malfunctions

See "Instructions for Use for the RCS Climbing Device and Hydraulics"

- Uneven cylinder extension and retraction
- Cylinder sinks
- Hydraulic oil is leaking
- Cylinder does not extend

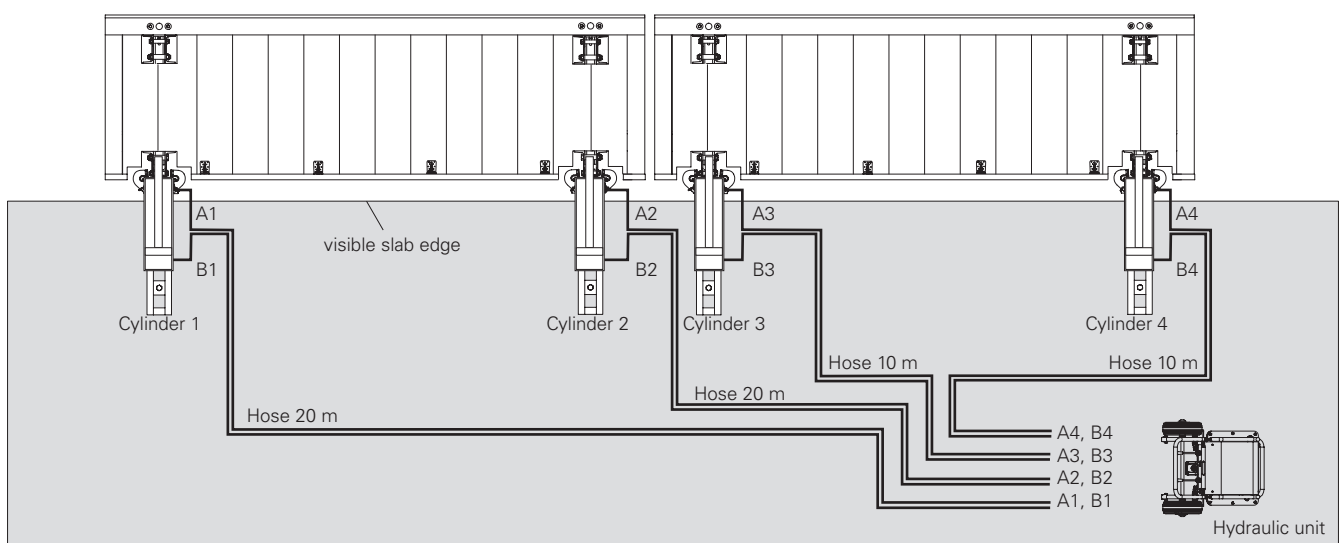

Fig. D4.01

Moving procedure

For a detailed explanation of the individual steps, see the following section.

Components

- 44** Climbing Shoe RCS
- 60** Climbing Device RCS 50

1. Activate climbing pawls on the middle climbing shoe (**44b**).
2. Variant 4 only: mount and anchor the top slab shoe on the protruding climbing rail.
3. Insert the climbing device (**60**) and engage with the bolt of the middle climbing shoe (**44b**).
4. Fold up foldable covers (**41**) and secure.
5. All personnel to leave the climbing enclosure; control climbing procedure from a safe position.
6. Raise the climbing enclosure from the middle climbing shoe with the climbing device (**60**) in 50 cm steps. (Fig. D4.01)
7. Variant 1 - 3 only: When the climbing rail (**2**) reaches the upper climbing shoe (**44a**):
 - Stop the climbing procedure and insert the climbing rail into the slab shoe.
 - Continue climbing.
8. After the required protection height has been reached:
 - Stop the climbing procedure.
 - Position the climbing unit with spacer on the middle slab shoes.

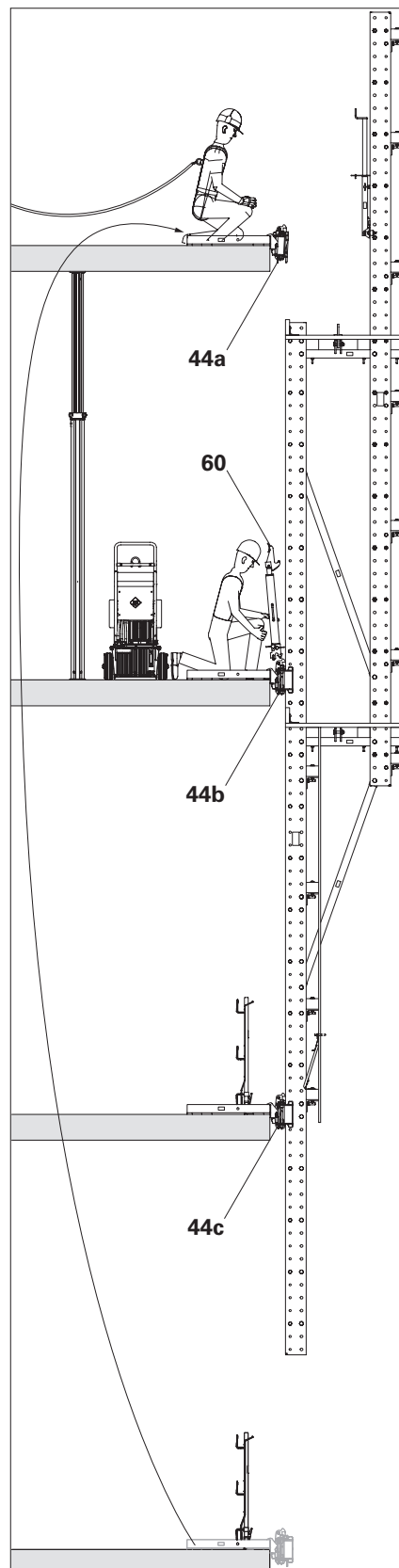

Variant 4 only:

- Deactivate climbing pawls of the top climbing shoes (**44a**).
- Open the guiding skids.
- Place climbing shoes on protruding climbing rail.
- Anchor the slab shoe (**45**).
- Pull the climbing rail onto the climbing shoe using the guide-in tool.
- Close the guiding skids.
- Remove the guide-in tool.

Fig. D4.01

Self-climbing procedure

Components for step 1

- 44** Climbing Shoe RCS
- 44.1** Climbing pawl
- 44.6** Bolt
- 60** Climbing Device RCS 50
- 60.6** Locking lever

Step 1

1. Remove the cover mat above the climbing shoe.
2. Position the Climbing Device RCS (**60**) on the bolts (**44.6**) of the middle climbing shoes (**44b**) and engage. The climbing device is pressed against the climbing rail through spring force. Guide the claw into the climbing rail. (Fig. D4.02 + D4.02a)
3. Attach twin hoses to the hydraulic unit and create a short-circuit connection at the other end by coupling them together.
4. Switch on the hydraulic unit and flush the hose for approx. 1 minute by operating the hand valve.
5. Disconnect the hose ends from one another and connect to the cylinder.

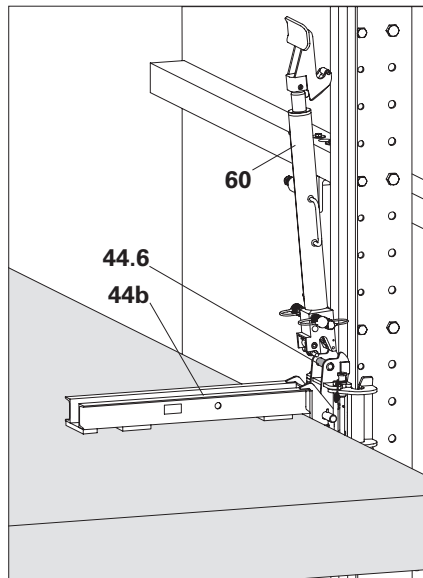

Fig. D4.02

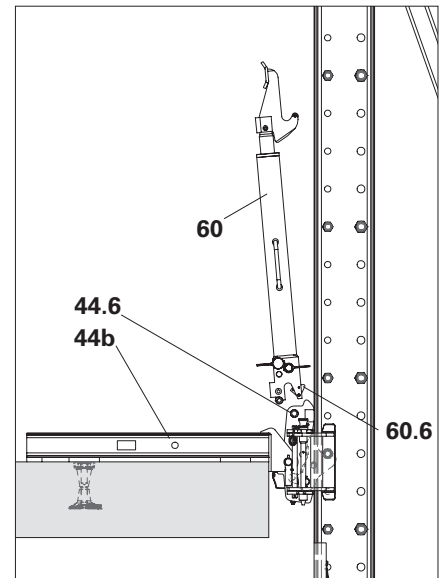

Fig. D4.02a



- Is the locking lever (**60.6**) fully engaged on the cylinder base?
- No possibility of the hydraulic hoses becoming entangled?

Components for steps 2 - 4

- 3** Spacer M20-82
- 44** Climbing Shoe RCS
- 44.1** Climbing pawl
- 60** Climbing Device RCS 50
- 60.1** Claw

Step 2

Warning!

Use personal protective equipment to prevent falling from a height.

1. Fold up foldable covers and secure.
2. Extend the hydraulic cylinder (**60**) up to the first spacer (**3**).
3. Load is now carried by the piston with claw (**60.1**). (Fig. D4.03)
4. If necessary, activate the climbing pawls of the middle slab shoes (**44b**) and deactivate the others.



Are all claws engaged in the spacers?



If the foldable covers (**41**) collide with the hoses or hydraulic climbing device during opening:

- Trim the covers.

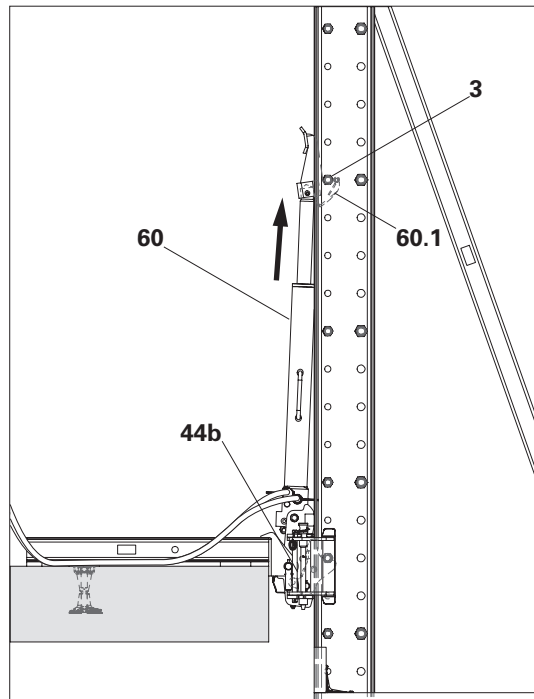

Fig. D4.03

Step 3

1. Fully extend the hydraulic cylinder.
2. The climbing pawl (**44.1**) in the climbing shoe is pressed inwards by the spacer when climbing past, then unfolded again by means of the spring force (audible click).

(Fig. D4.04)



Are the climbing pawls (**44.1**) of all middle slab shoes (**44b**) engaged in the climbing rail?

If not:

- Fully extend the hydraulic cylinder.
Due to the end position compensation, the following cylinder moves very slowly.
- Climb back, remove cylinder and bleed.

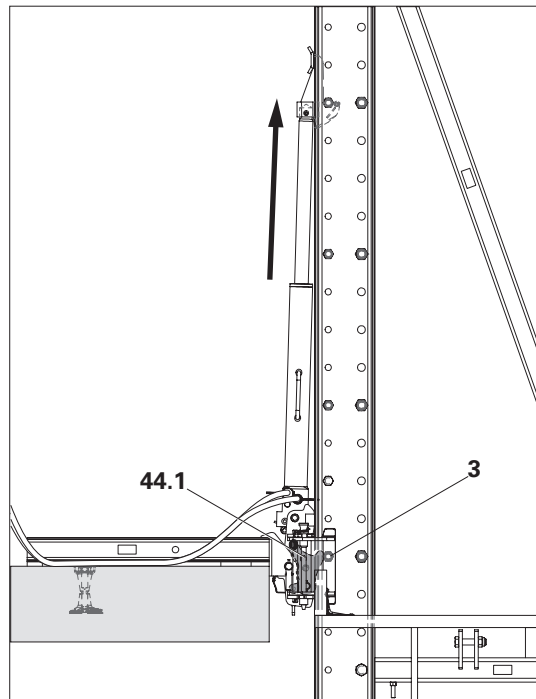

Fig. D4.04

Step 4

1. Retract all hydraulic cylinders until:
 - The load is carried by the climbing pawl (**44.1**) in the middle slab shoe (**44b**),
 - the claw is relieved by the spacer.

(Fig. D4.05)

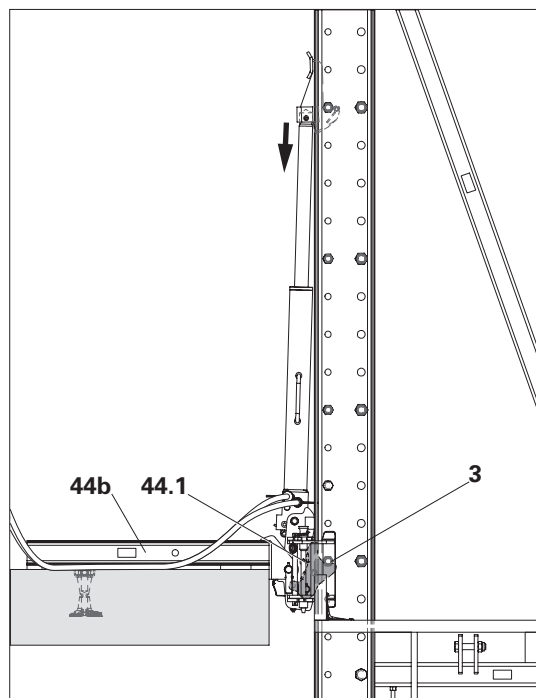

Fig. D4.05

Components for steps 5 - 7

- 3** Spacer M20-82
- 44** Climbing Shoe RCS
- 44.2** Guiding skid
- 60** Climbing Device RCS 50
- 60.1** Claw
- 126** Guide-In Tool RCS

Step 5

1. Retract hydraulic cylinder until it tilts backwards, claw (**60.1**) slides past the spacers (**3**) positioned underneath and engages again below. (Fig. D4.06)



Are all claws under the spacers correctly engaged?
Otherwise press down by hand.
If necessary, further retract the hydraulic cylinder.

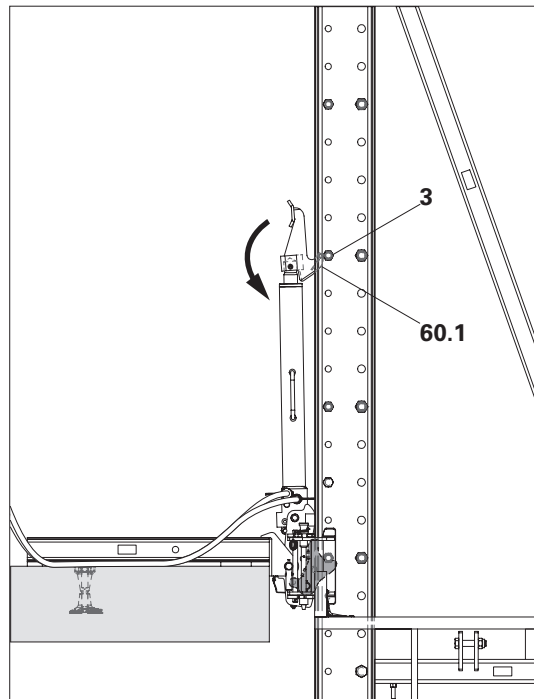

Fig. D4.06

Step 6

1. Extend the hydraulic cylinder.
→ The claw grips the spacer and raises the climbing rail.
2. By repeating steps 3 to 6 several times, the climbing unit is gradually climbed upwards in increments of 50 cm. (Fig. D4.07)



If the hydraulic hoses become taut or entangled, immediately stop the climbing procedure and eliminate the problem!

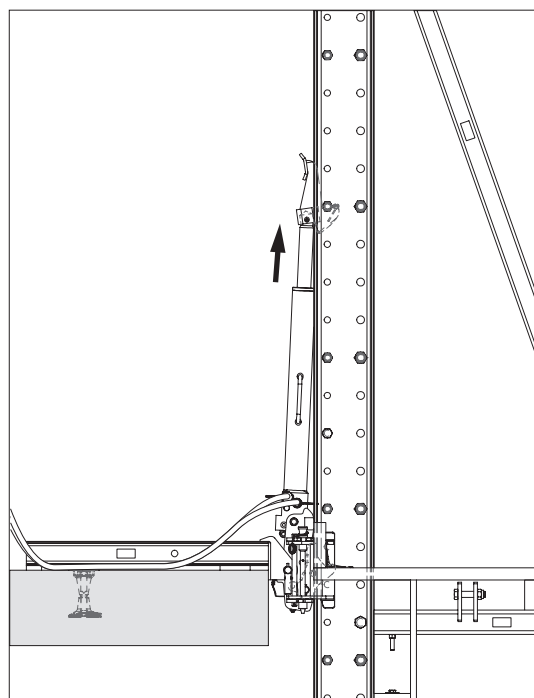

Fig. D4.07

Step 7 (Variant 1-3)

When the top climbing shoe has been reached:

1. Stop the climbing procedure.
 2. Pull the climbing rail inwards by means of the guide-in tool (126).
 3. Close the guiding skids (44.2) of the top climbing shoe (44a). Deactivate the climbing pawls.
 4. Remove the guide-in tool.
 5. Continue the climbing procedure.
- (Fig. D4.08 + D4.08a)

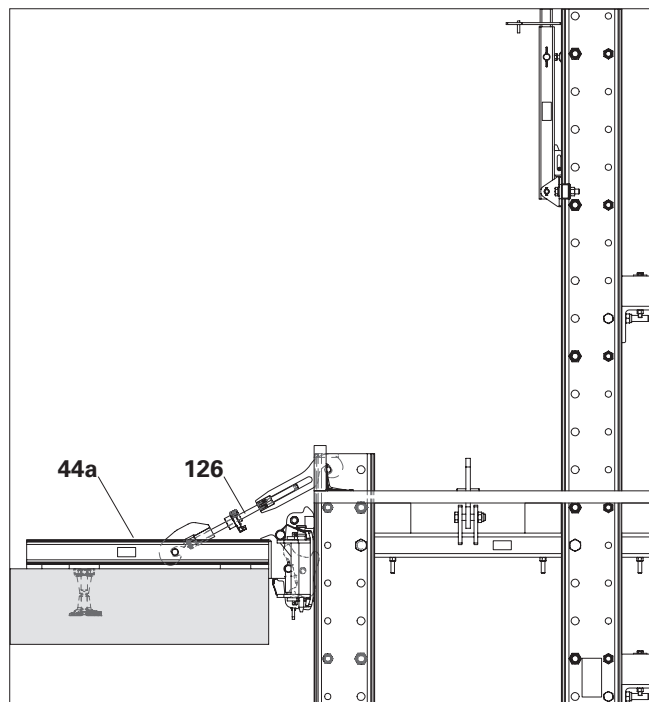

Fig. D4.08

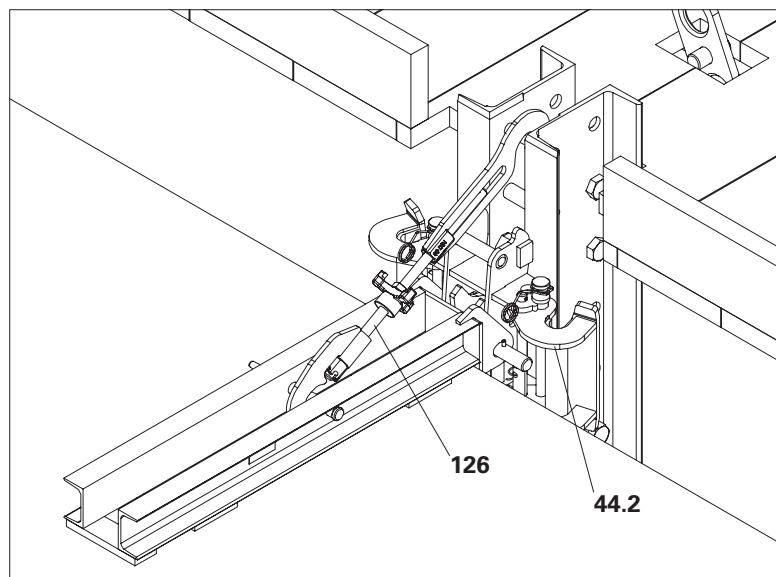

Fig. D4.08a

Components for steps 8 - 9

- 3** Spacer M20-82
- 41** Foldable cover
- 44** Climbing Shoe RCS
- 60** Climbing Device RCS 50
- 60.1** Claw
- 60.6** Locking lever

Step 8

During the final lift:

1. Extend hydraulic cylinders until all climbing pawls of the middle climbing shoes (**44b**) engage in the correct spacers.

(Fig. D4.09)



Are the climbing pawls of all middle climbing shoes (**44b**) engaged?

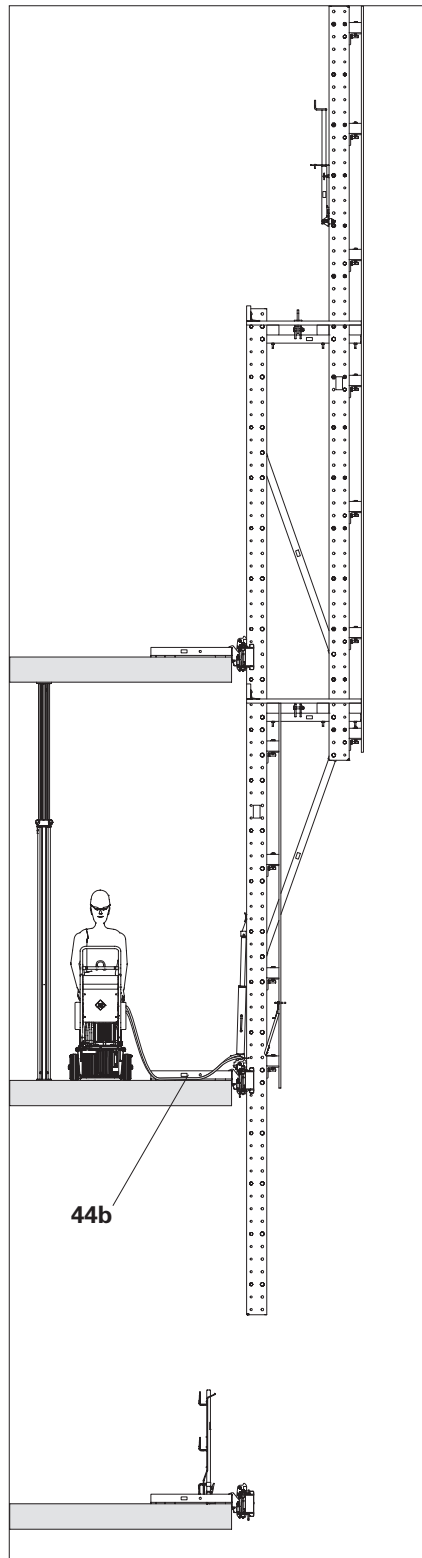

Fig. D4.09

Step 9

1. Completely retract all hydraulic cylinders until:
 - The load is carried by the climbing pawl in the middle slab shoe (44b),
 - the claw (60.1) is relieved by the spacer (3).
2. Detach hydraulic hoses from the climbing device using the quick couplers.
3. Close the foldable covers (41).
4. Tilt the climbing device backwards, operate the locking lever (60.6) on the cylinder base and lift out the climbing device. (Fig. D4.10 + D4.10a)
5. Transport the hydraulic unit, climbing device and hydraulic hoses to the next climbing enclosure.



In order to prevent the locking lever immediately engaging again after releasing, press the climbing device slightly to the side.



When the hydraulic cylinders are not in use, always retract the pistons completely.

Concluding work

1. Fold down the foldable covers and close any remaining gaps.
2. Complete the guardrails.
3. Dismantle the trailing slab shoe, see Section "Dismantling the suspension" on page 115.
4. Remove anchoring that is no longer needed, see Section "Dismantling the anchoring" on page 117.

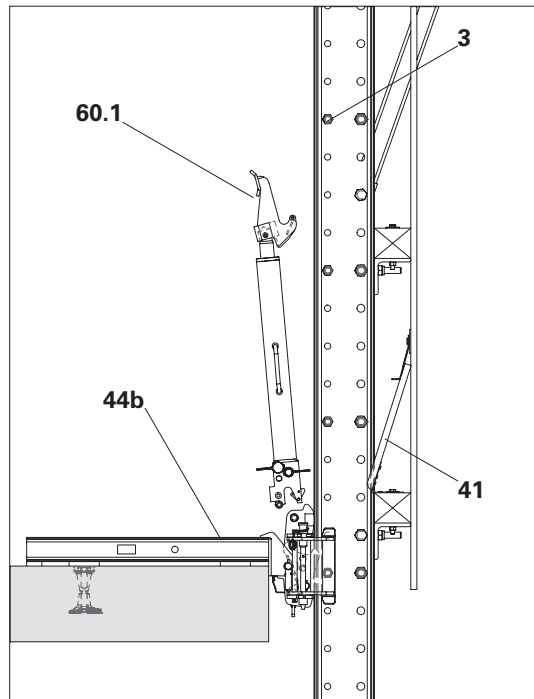

Fig. D4.10

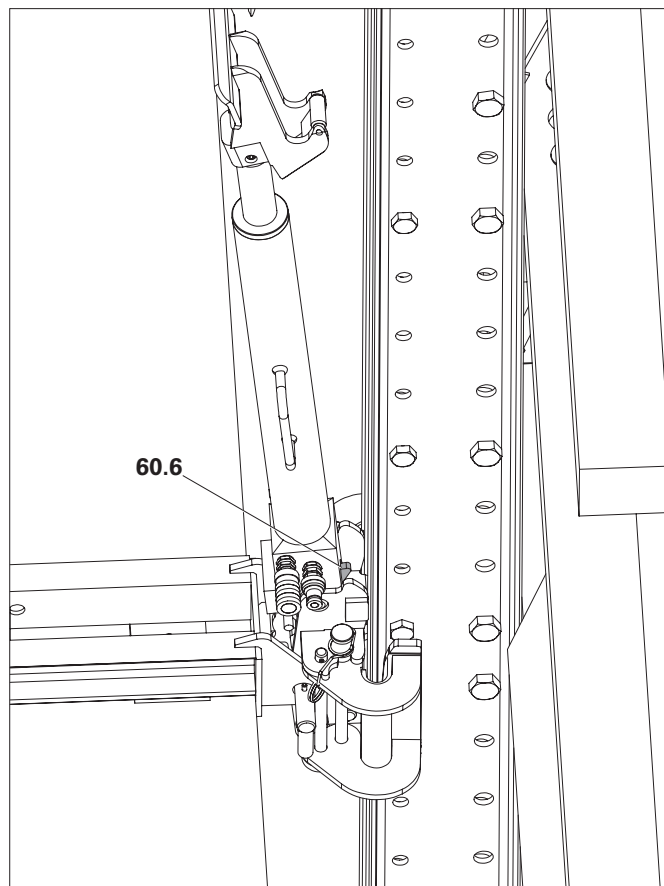

Fig. D4.10a

Removing the climbing enclosure



Warning

As a result of removing the climbing enclosure, unsecured building edges are formed!

A fall can result in serious injury or even death.

- ⇒ Install guardrails before removing the climbing enclosure.
- ⇒ Areas of risk are to be cordoned off.
- ⇒ Use personal protective equipment to prevent falling from a height.

Components

- 41** Foldable cover
- 44** Climbing Shoe RCS
- 85** Guardrail

Preparations

1. Remove connections between the climbing enclosures.
 2. Dismantle formwork in the area of the slab edge.
 3. Mount guardrails (**85**) on all unsecured slab edges.
 4. Remove cover mats, fold up and secure foldable covers (**41**).
 5. Remove or secure all loose components.
 6. Install Lifting Eye BR-2 2.5 t, see Section "Assembly of attachment points" on page 69.
 7. Secure guide ropes to the climbing enclosure.
 8. Attach crane lifting gear to Lifting Eye BR-2.
- (Fig. E1.01)

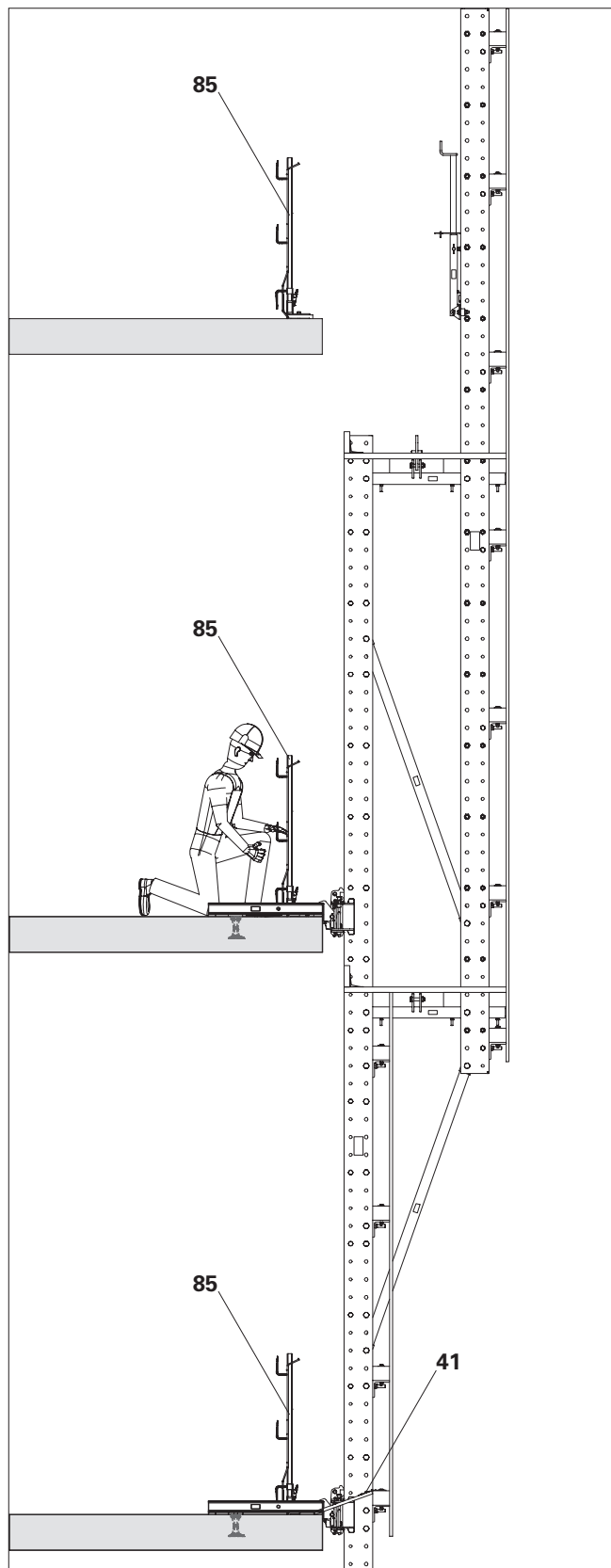

Fig. E1.01

Removing the climbing enclosure



Warning

Hands can become trapped between climbing rails and slab shoes!

This can result in serious injuries.

- ⇒ Do not take hold of anything between the rail guidance shoes and climbing rails while the climbing enclosure is moving.
- ⇒ Do not open the foldable skirts if the climbing rail is pressing against them.

1. Leave the climbing enclosure platforms.
 2. Open the guiding skirts of the bottom climbing shoes (44c).
 3. Lift the climbing enclosure slightly with the crane in order to relieve the middle slab shoes (44b).
 4. Open the guiding skirts on the middle slab shoes (44b).
 5. Move climbing enclosure away from the building with the crane and transport to a suitable dismantling area.
 6. Dismantle the remaining slab shoes (44b, 44c) and remove the anchoring.
 7. Complete the guardrails.
- (Fig. E1.02)

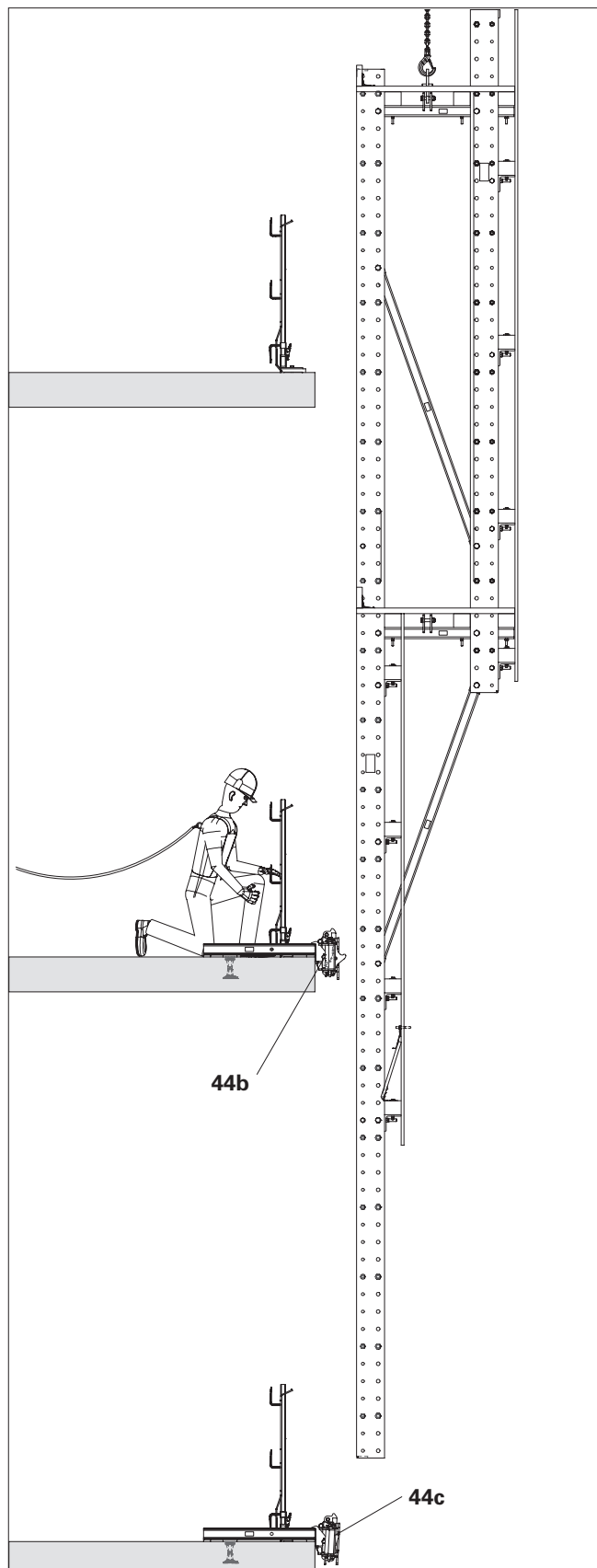

Fig. E1.02

Dismantling the climbing enclosure

Components

- 1 Enclosure post
- 2 Climbing Rail RCS
- 10 Crossbar RCS 103
- 12 Diagonal Strut RCS 212
- 14 Enclosure beam (squared timber)
- 40 Platform beam (squared timber)

Dismantling the enclosure

1. Place the climbing unit with the enclosure above on the dismantling area.
2. Remove the enclosure from the enclosure beams.
3. Remove decks from the platform beams.
4. Dismantle the foldable covers.
5. Remove any remaining bracing.

Dismantling the framework

1. Remove the enclosure beams from the enclosure posts.
 2. Remove the platform beams (40) from the crossbars (10).
 3. Remove the enclosure posts (1) from both console bracket units.
- (Fig. E1.03 + E1.04)

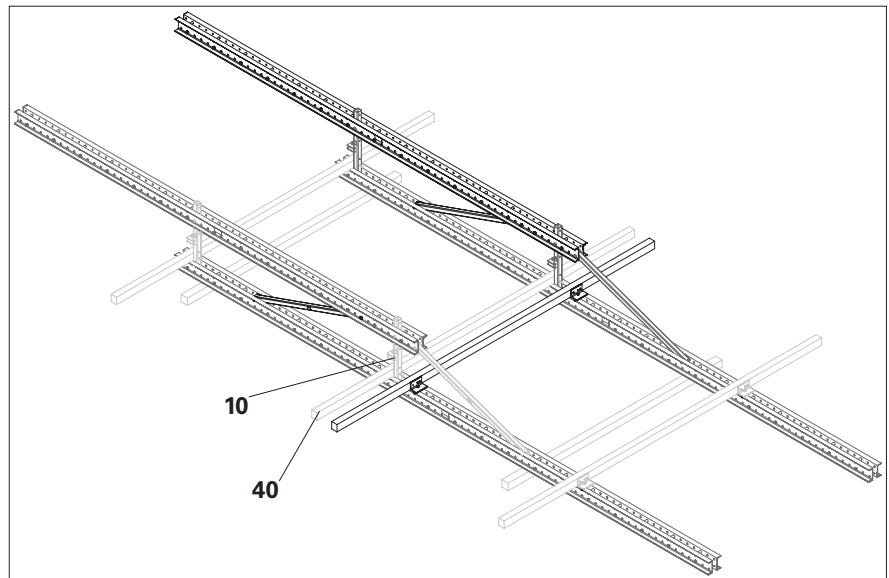

Fig. E1.03

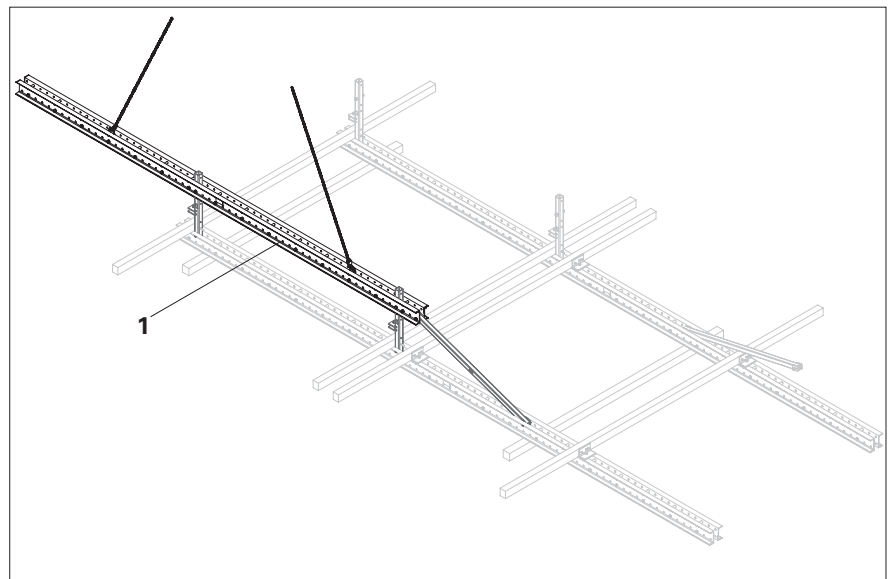

Fig. E1.04

4. Remove crossbars (**10**) and diagonal struts (**12**) from the climbing rails (**2**). (Fig. E1.05)
5. Remove the enclosure beam (**14**) from the climbing rails. (Fig. E1.06)
6. Put spacers back in original position, remove any additional spacers.
7. Remove squared timber adapters, lifting eyes and other mounting parts.



- Spacers in the climbing rails must be moved back to their original positions, see Section "C1 Pre-assembly of console brackets – Preparation of climbing rails". Failing to do so can lead to considerable malfunctions during climbing operations with corresponding additional assembly work during the next use due to displaced or additional spacers.
- In the case of rented equipment, PERI may subsequently invoice for the cost of dismantling.
- Non-reusable materials are to be disposed of in a suitable and environmentally-friendly manner.

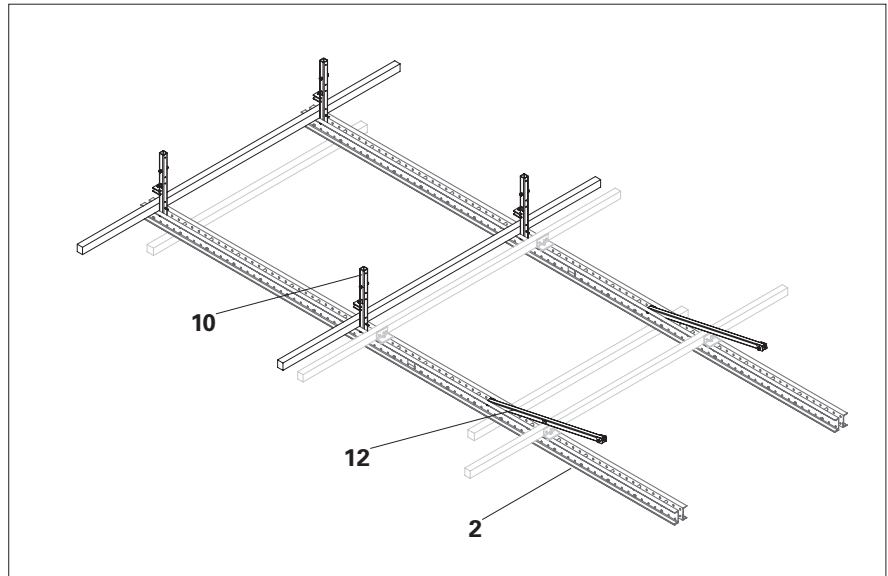

Fig. E1.05

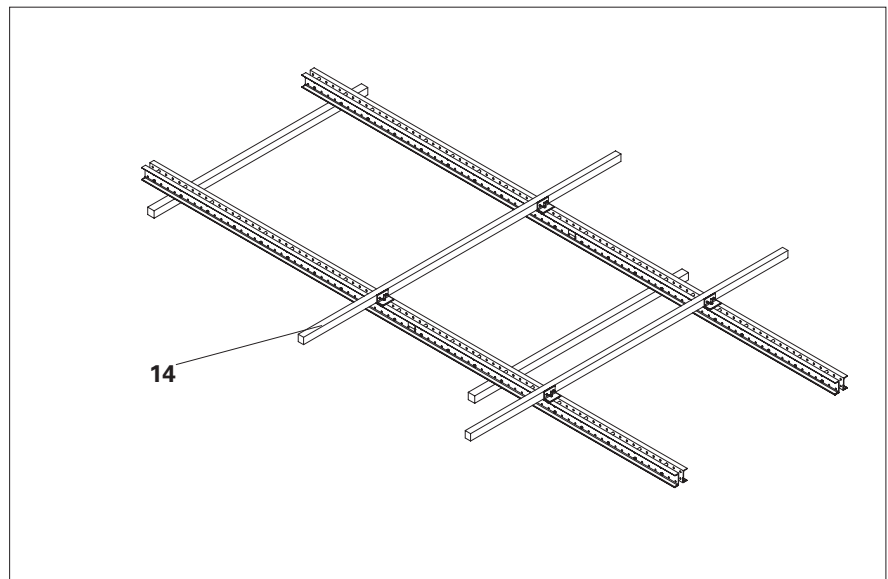

Fig. E1.06

RCS-P

Art no.	Weight [kg]		L [mm]
		Climbing Rails RCS	
114166	78.200	CLIMBING RAIL RCS 148	1480
109469	130.000	CLIMBING RAIL RCS 248	2480
112102	156.000	CLIMBING RAIL RCS 298	2980
109470	182.000	CLIMBING RAIL RCS 348	3480
112141	209.000	CLIMBING RAIL RCS 398	3980
109471	262.000	CLIMBING RAIL RCS 498	4980
109472	393.000	CLIMBING RAIL RCS 748	7480
109610	524.000	CLIMBING RAIL RCS 998	9980

Steel profile for all-purpose use of climbing application or civil constructions. With Spacer M 20-82 and M 24-82.

Notes

2 x U200 DIN 1026

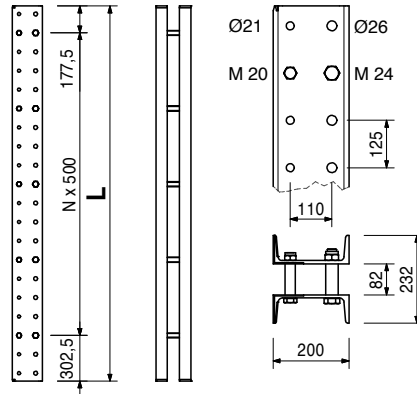

Accessory (not included)

136109	0.472	PIN SET RCS MAX
--------	-------	------------------------

Art no.	Weight [kg]	
110022	0.491	SPACER M20-82

Spacer for Climbing Rails RCS.

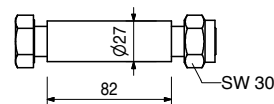
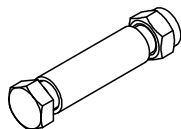

Consists of

- 1 pc 104477 Bolt ISO 4014 M20 x 120-8.8, galv.
- 1 pc 130341 Nut ISO 7042 M20-8, galv.

Art no.	Weight [kg]	
110023	0.910	SPACER M24-82

Spacer for Climbing Rails RCS.

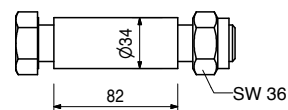
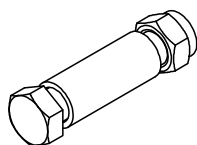

Consists of

- 1 pc 109612 Bolt ISO 4014 M24 x 130-8.8, galv.
- 1 pc 130342 Nut ISO 7042 M24-8, galv.

RCS-P

Art no.	Weight [kg]	
115626	1.880	KICKER CONNECTOR RCS M24

Bolted in holes Ø 26 of the Climbing Rail RCS. Serves for connecting Kicker AV or Bracing DW 15.

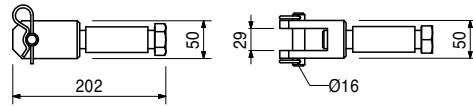
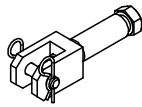

Consists of

- 2 pc 018060 Cotter Pin 4/1, galv.
- 1 pc 109612 Bolt ISO 4014 M24 x 130-8.8, galv.
- 1 pc 115916 Pin Ø = 16, L = 70 mm, geomet.

Art no.	Weight [kg]	
110569	16.700	CLIMBING RAIL HINGE RCS

For an articulated connection of the Climbing Rails RCS and as pressure point on the RCS Climbing Brackets.

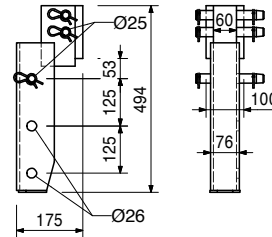
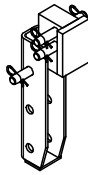

Consists of

- 4 pc 018060 Cotter Pin 4/1, galv.
- 3 pc 710894 Pin Ø 25 x 180, geomet.

Art no.	Weight [kg]	
109791	25.900	CLIMB. RAIL EXTENSION 100 RCS

As extension of the Climbing Rail RCS for connecting the finishing platform.

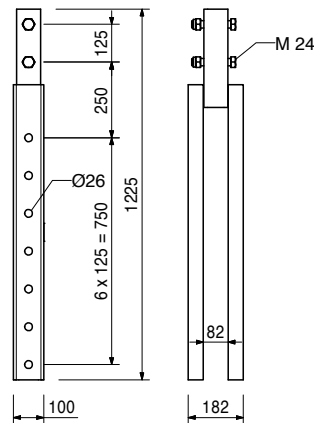
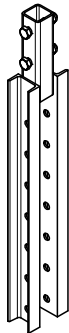

Consists of

- 2 pc 105032 Nut ISO 7040 M24-8, galv.
- 2 pc 109612 Bolt ISO 4014 M24 x 130-8.8, galv.

RCS-P

Art no.	Weight [kg]	
---------	-------------	--

113744	21.000	CLIMBING RAIL CONNECTOR RCS 73
--------	--------	---------------------------------------

For rigid connection of Climbing Rails RCS. Perm. bending moment limited.

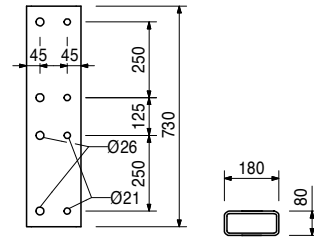

Accessory (not included)

018060	0.014	COTTER PIN 4/1, GALV.
022230	0.033	COTTER PIN 5/1, GALV.
104031	0.462	FILLER PIN D=21X120
111567	0.729	PIN D=26X120

Art no.	Weight [kg]	
---------	-------------	--

109743	6.370	CLIMBING RAIL COUPLING RCS 32
--------	-------	--------------------------------------

For an articulated connection of Climbing Rails RCS.

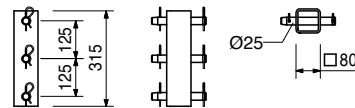
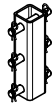

Consists of

6 pc 018060 Cotter Pin 4/1, galv.
3 pc 710894 Pin Ø 25 x 180, geomet.

Art no.	Weight [kg]	
---------	-------------	--

123534	5.910	BRACE CONNECTOR RCS DW15/M20
--------	-------	-------------------------------------

For mounting diagonal bracing with Tie Rod DW 15 and a compression strut to the Climbing Rail RCS.

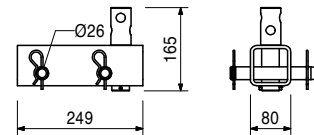
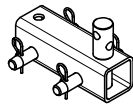

Consists of

4 pc 018060 Cotter Pin 4/1, galv.
2 pc 710894 Pin Ø 25 x 180, geomet.

Art no.	Weight [kg]	
---------	-------------	--

104031	0.462	FILLER PIN D=21X120
--------	-------	----------------------------

For different connections.

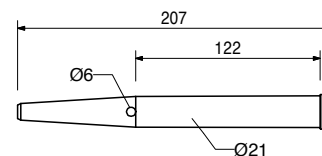
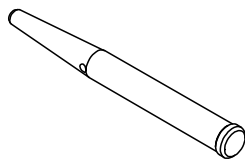

Accessory (not included)

018060	0.014	COTTER PIN 4/1, GALV.
--------	-------	------------------------------

Art no.	Weight [kg]	
018060	0.014	COTTER PIN 4/1, GALV.

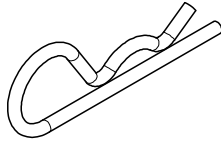

Art no.	Weight [kg]	
111567	0.729	PIN D=26X120

For different connections.

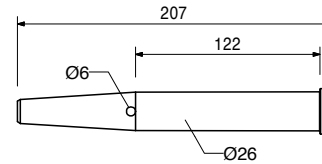
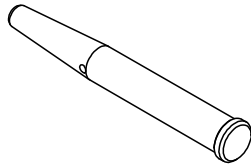

Accessory (not included)

018060	0.014	COTTER PIN 4/1, GALV.
--------	-------	------------------------------

Art no.	Weight [kg]	
022230	0.033	COTTER PIN 5/1, GALV.



Art no.	Weight [kg]	
111631	10.100	CROSSBAR RCS 69

As horizontal bar or strut for assembly as Climbing Protection Panel (platform width 1.00 m).

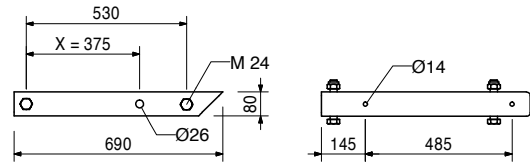
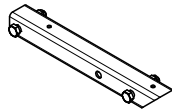

Accessory (not included)

110599	0.242	HEX BOLT ISO4017-M12X240-8.8-G
113348	0.043	WASHER ISO7094-12 100HV, GALV.
710330	0.017	HEX NUT ISO4032-M12-8-VZ

Consists of

- 2 pc 105032 Nut ISO 7040 M24-8, galv.
- 2 pc 109612 Bolt ISO 4014 M24 x 130-8.8, galv.

Art no.	Weight [kg]	
110234	18.200	CROSSBAR 103 RCS

As horizontal bar for assembly as Climbing Protection Panel (platform width 1.32 m).

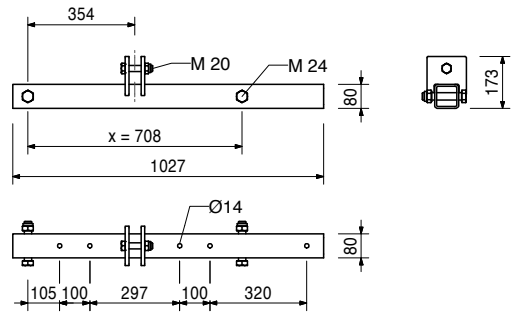
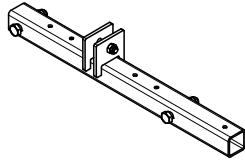

Accessory (not included)

110599	0.242	HEX BOLT ISO4017-M12X240-8.8-G
113348	0.043	WASHER ISO7094-12 100HV, GALV.
710330	0.017	HEX NUT ISO4032-M12-8-VZ

Consists of

- 2 pc 105032 Nut ISO 7040 M24-8, galv.
- 2 pc 109612 Bolt ISO 4014 M24 x 130-8.8, galv.
- 1 pc 710226 Bolt ISO 4014 M20 x 90-8.8, galv.
- 1 pc 781053 Nut ISO 7040 M20-8, galv.

Art no.	Weight [kg]		L [mm]	X [mm]	Y [mm]
110012	23.500	DIAGONAL STRUT L= 2121MM RCS	2217	1500	1500

For bracing RCS Framework Brackets.

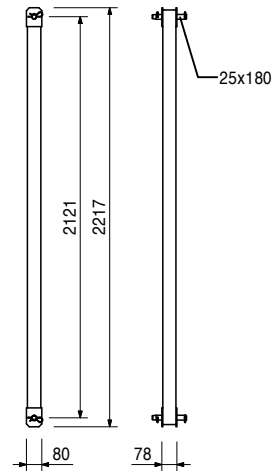
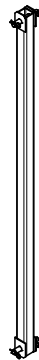

Consists of

- 1 pc 018060 Cotter Pin 4/1, galv.
- 1 pc 105032 Nut ISO 7040 M24-8, galv.
- 2 pc 109612 Bolt ISO 4014 M24 x 130-8.8, galv.
- 1 pc 710894 Pin Ø 25 x 180, geomet.

RCS-P

Art no.	Weight [kg]	
110290	5.030	TIMBER FIXATION RCS

For assembly of timbers on the Climbing Rails RCS for use as climbing protection panel.

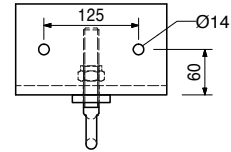
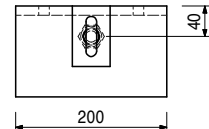
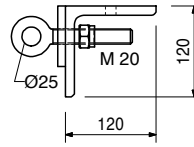
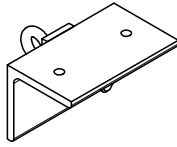

Accessory (not included)

018330	0.140	HEX BOLT 4016-M12X140-4.6-VZMU
027340	0.180	HEX BOLT 4016-M12X180-4.6-VZMU
070030	0.015	PLATE CONNECTOR 50/12 SINGLE
113348	0.043	WASHER ISO7094-12 100HV, GALV.

Consists of

- 1 pc 110281 Eye Bolt M20, right, galv.
- 1 pc 781053 Nut ISO 7040 M20-8, galv.

Art no.	Weight [kg]	
126430	4.460	ADAPTER VT20 / RCS-P

For mounting a horizontal positioned Girder VT 20 onto the Climbing Profile RCS.

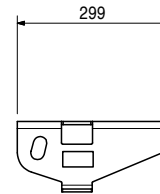
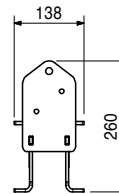
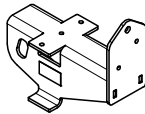

Accessory (not included)

024470	0.008	TSS-TORX 6X60, GALV.
104477	0.300	HEX BOLT ISO4014 M20X120-8.8,G
105032	0.070	HEX NUT ISO7040-M24-8-GALV.
109612	0.600	HEX.BOLT ISO4014 M24X130-8.8GV
781053	0.065	HEX NUT ISO7040-M20-8-VZ

Art no.	Weight [kg]	
128519	6.840	ENCLOSURE ADAPTER RCS D26-D21

For the fixation of horizontal Enclosure Girders GT 24 or Climbing Rails profile RCS U200 on vertical Climbing Rails RCS.

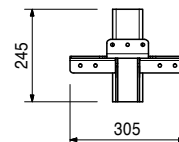
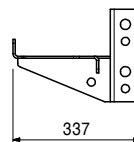
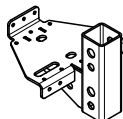

Accessory (not included)

104477	0.300	HEX BOLT ISO4014 M20X120-8.8,G
105032	0.070	HEX NUT ISO7040-M24-8-GALV.
109612	0.600	HEX.BOLT ISO4014 M24X130-8.8GV
781053	0.065	HEX NUT ISO7040-M20-8-VZ

RCS-P

Art no.	Weight [kg]	
128671	19.100	CLIMBING RAIL CONN. RCS/LPS 73

For height extension of Climbing Rails RCS in combination with Screen Elements LPS.

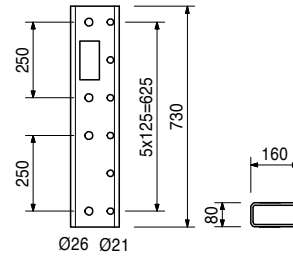
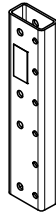

Accessory (not included)

127875	2.000	SCREEN SUPPORT LPS M20
--------	-------	-------------------------------

Art no.	Weight [kg]	
		Steel Scaffold Tubes Ø 48.3 x 3.2, special length
026417	0.000	CUTTING COST SCAFFOLD TUBE
026411	3.550	SCAFFOLD TUBE 48,3x3,2 L=1,0M
026412	7.100	SCAFFOLD TUBE 48,3x3,2 L=2,0M
026413	10.650	SCAFFOLD TUBE 48,3x3,2 L=3,0M
026414	14.200	SCAFFOLD TUBE 48,3x3,2 L=4,0M
026419	17.750	SCAFFOLD TUBE 48,3X3,2 L=5,0M
026418	21.600	SCAFFOLD TUBE 48,3x3,2 L=6,0M
026415	3.550	SCAFFOLD TUBE 48,3x3,2 LFM
125976	8.900	SCAFF TUBE 48,3X3,2X2500, GALV
114287	12.500	SCAFF TUBE 48,3X3,2X3500, GALV

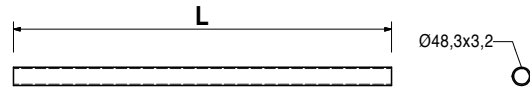
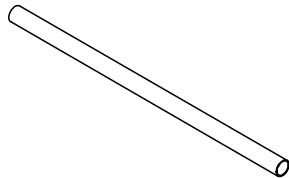

Art no.	Weight [kg]	
017010	1.400	SWIVEL COUPLER SW 48/48 GALV.

For scaffold tubes Ø 48 mm.

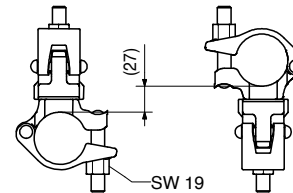
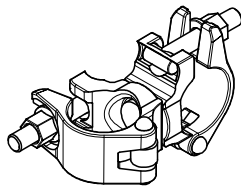

Art no.	Weight [kg]	
017020	1.120	STANDARD COUPLER RA 48/48 GALV

For scaffold tubes Ø 48 mm.

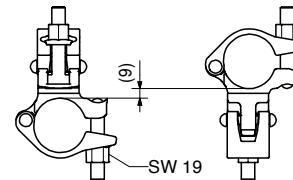
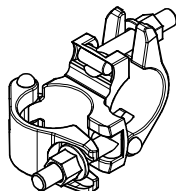

Art no.	Weight [kg]	
070030	0.015	PLATE CONNECTOR 50/12 SINGLE

To strengthen the timber fixation and for other connections of timber with steel.



Art no.	Weight [kg]	
111436	0.150	HINGE DIN7957-200-ST-ZN

For mounting the cover flap at the climbing protection panel.

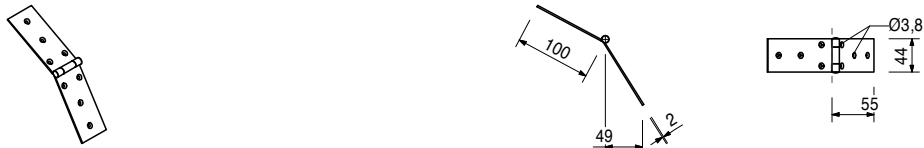

Accessory (not included)

110642	0.006	SPAX 5X 40 SK-TX 25, YELL GAL.
111437	0.004	SPAX 5X 20 SK-TX 25, YELL GAL.

Art no.	Weight [kg]	
114937	0.402	FIXATION BAR RCS

For fixing the cover flap to the climbing protection panel during climbing.

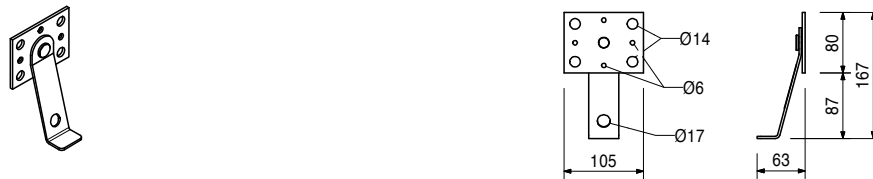

Accessory (not included)

111437	0.004	SPAX 5X 20 SK-TX 25, YELL GAL.
--------	-------	---------------------------------------

Art no.	Weight [kg]	
123478	0.255	ANGLE BRACKET 90 REINFORCED

For diverse timber connections.



Accessory (not included)

024550	0.005	SPAX 8X20 TX30
129711	0.010	SPAX 6X20 TX30

Art no.	Weight [kg]		L [mm]
114727	0.321	SCREW ISO4017-M20X100-8.8-GALV	100



RCS-P

Art no.	Weight [kg]		L [mm]
104477	0.300	HEX BOLT ISO4014 M20X120-8.8,G	120

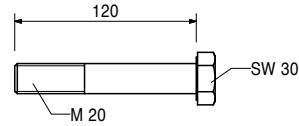
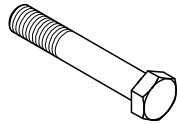

Accessory (not included)

781053	0.065	HEX NUT ISO7040-M20-8-VZ	
--------	-------	---------------------------------	--

Art no.	Weight [kg]		L [mm]
781053	0.065	HEX NUT ISO7040-M20-8-VZ	

Self-locking.

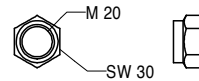

Art no.	Weight [kg]		L [mm]
109612	0.600	HEX.BOLT ISO4014 M24X130-8.8GV	130

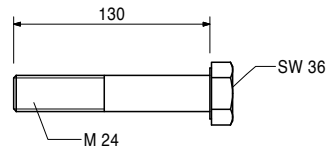
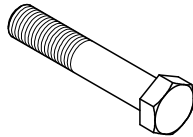

Art no.	Weight [kg]		L [mm]
105032	0.070	HEX NUT ISO7040-M24-8-GALV.	

Self-locking.

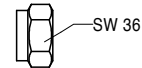

Art no.	Weight [kg]		L [mm]
		TSS-Torx, galv.	
024470	0.008	TSS-TORX 6X60, GALV.	60
024690	0.008	TSS-TORX 6X80, GALV.	80

For Torx Blade TX 30. Self-drilling.

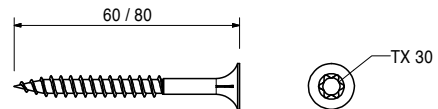
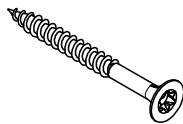

Art no.	Weight [kg]		L [mm]
		Spax Screws TX 25	
111437	0.004	SPAX 5X 20 SK-TX 25, YELL GAL.	20
110642	0.006	SPAX 5X 40 SK-TX 25, YELL GAL.	40

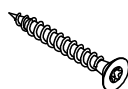

Art no.	Weight [kg]	
		Spax Screws TX 30
129711	0.010	SPAX 6X20 TX30
024550	0.005	SPAX 8X20 TX30

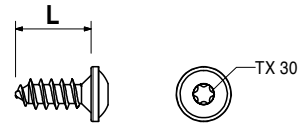

Art no.	Weight [kg]		L [mm]
024960	0.015	SPAX 6X120 SK-TX30,YELL. CHROM	120

For Torx Blade TX 30. Self-drilling.

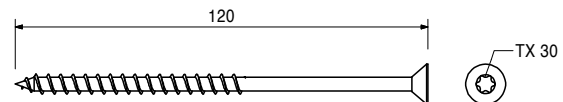
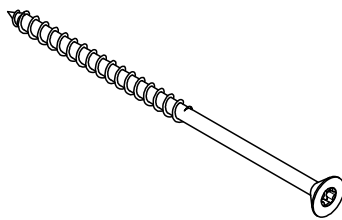

Art no.	Weight [kg]		L [mm]
		Hex. Wood Screws DIN 571	
051640	0.014	LAG SCREW 6X80 DIN571, GALV.	80
024270	0.023	LAG SCREW 8X 60 DIN 571, GALV.	60

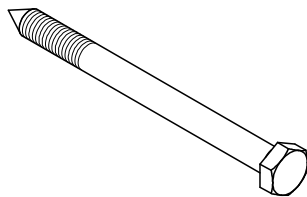

Art no.	Weight [kg]		B [mm]	L [mm]
		F.H. Bolt DIN 603		
024140	0.033	F.H BOLT M 8X70 W.NUT	58	70
024390	0.090	F.H BOLT M 8X200 W.NUT	150	200
024410	0.109	F.H BOLT M 8X250 W.NUT	150	250
710240	0.050	F.H BOLT M8X100 W.NUT	80	100
051650	0.060	F.H.BOLT M06X180MUDIN603-4.8VZ	24	180

With nut.

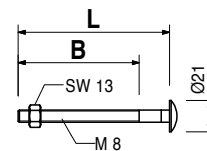
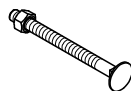

Art no.	Weight [kg]	
780354	0.002	WASHER ISO7089-08-200HV-VZ

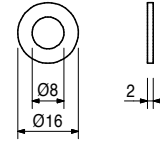
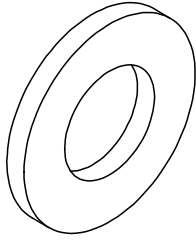

Art no.	Weight [kg]		L [mm]
		Bolt ISO 4017 M12, galv.	
110598	0.142	HEX BOLT ISO4017-M12X140-8.8-G	140
110599	0.242	HEX BOLT ISO4017-M12X240-8.8-G	240

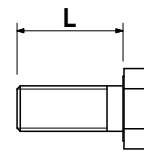
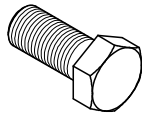

Art no.	Weight [kg]	
113348	0.043	WASHER ISO7094-12 100HV, GALV.

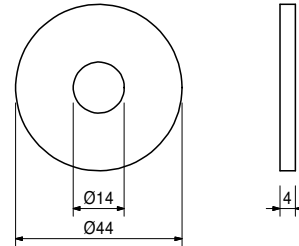
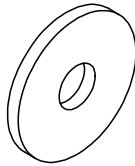

RCS-P

Art no.	Weight [kg]	
127320	158.000	LIFTING BEAM 9T

For moving climbing units.

Notes

Follow Instructions for Use.
Permissible load-bearing capacity 9 t.

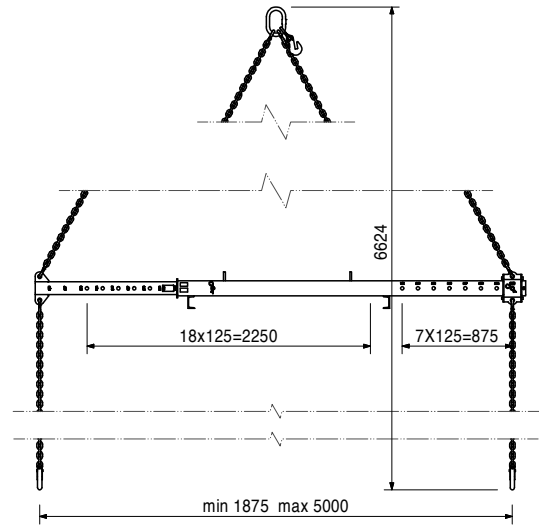
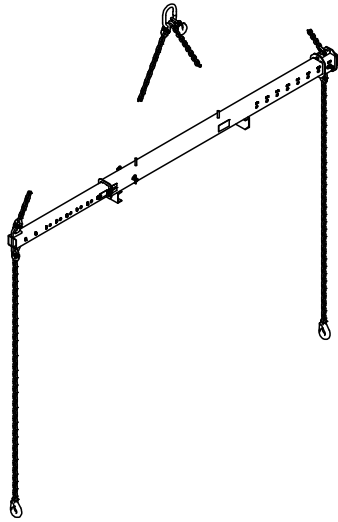

Consists of

- 1 pc 022230 Cotter Pin 5/1, galv.
- 1 pc 107297 Bolt ISO4014-M12 x 140-8.8, galv.
- 1 pc 112865 Bolt 25 x 180
- 1 pc 710330 Nut ISO 4032 M12-8, galv.

Art no.	Weight [kg]	
127834	2.210	CRANE EYE BR-2 2,5T, galv.

As attachment point for moving climbing systems or Platform Beam BR.

Notes

Follow Instructions for Use!
Permissible load-bearing capacity 2.5 t.

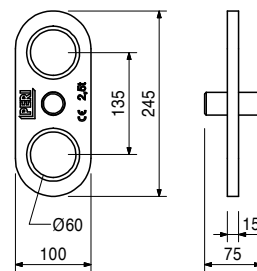

Accessory (not included)

020620	0.561	SPACER FOR PLATFORM BEAM BR
--------	-------	------------------------------------

Art no.	Weight [kg]	
114317	3.210	GUIDE-IN TOOL RCS

For pulling up the Climbing Rail RCS in order to close the folding runners of the Climbing Shoe.

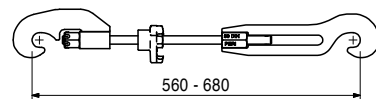
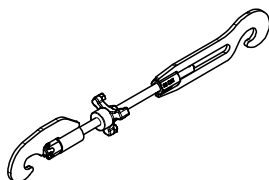

RCS-P

Art no.	Weight [kg]	
109468	19.800	CLIMBING SHOE RCS

Guide and support for Climbing Rail RCS. With foldable leading runners and self-actuating bearing pawl.

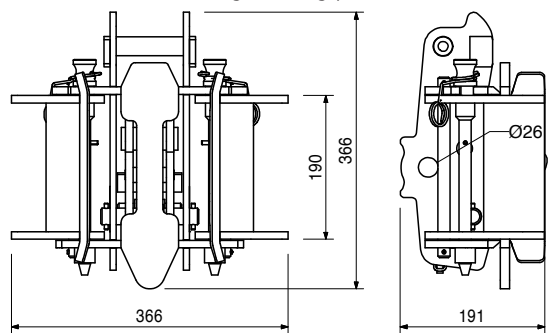
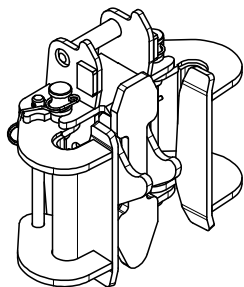

Consists of

- 2 pc 109508 Pin Ø 16 x 239, galv.
- 2 pc 109902 Pin Ø 30 x 290, galv.
- 1 pc 109903 Spring Lock
- 2 pc 116067 Locking Device
- 4 pc 711063 Dowel Pin Ø 5 x 35
- 4 pc 750329 Dowel Pin Ø 5 x 20

135962	0.379	Climbing Shoe Display RCS MAX For use as Climbing Shoe Display RCS	Complete with 1 pc. 711071 Nut ISO 7040 M8-8, galv. 1 pc. 126908 bolt ISO 4014 M8 x 45-8.8, galv.
--------	-------	--	--

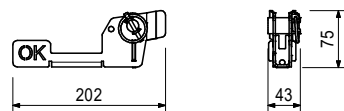
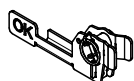

Art no.	Weight [kg]	
109567	20.200	SLAB SHOE RCS

Anchor System M24. For mounting Climbing Shoe RCS to slab edges.

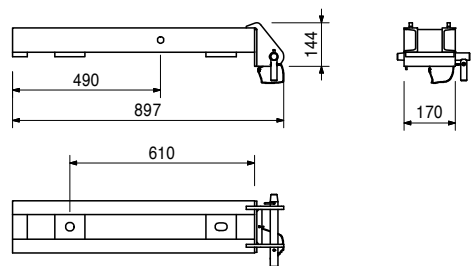
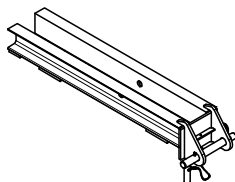

Consists of

- 1 pc 022230 Cotter Pin 5/1, galv.
- 1 pc 715585 Pin Ø 25 x 240, SKS, galv.

Art no.	Weight [kg]	
110375	30.800	DECKENSCHUH ECKE RCS

Anchor System M24. For mounting Climbing Shoe RCS to the corners of slab edges.

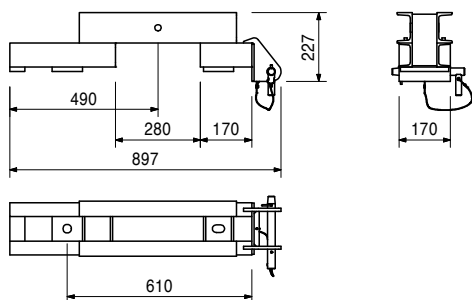
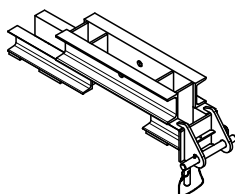

Consists of

- 1 pc 022230 Cotter Pin 5/1, galv.
- 1 pc 715585 Pin Ø 25 x 240, SKS, galv.

RCS-P

Art no.	Weight [kg]	
115570	54.400	SLAB SHOE RCS 30 ADJUSTABLE

Anchor System M24. For mounting the Climbing Shoe RCS to slab edges. Offset up to 30 cm. Anchor distance variable 61 ± 5 cm or 76 ± 5 cm.

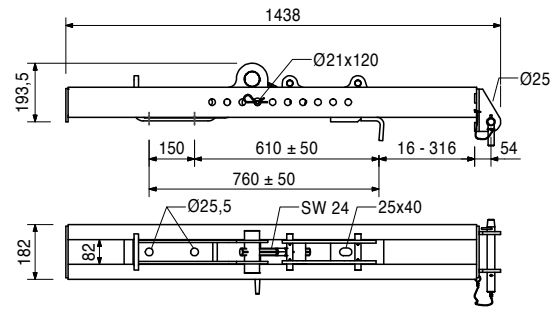
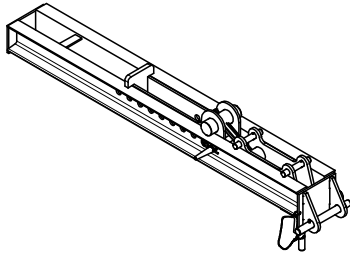

Consists of

- 2 pc 022230 Cotter Pin 5/1, galv.
- 1 pc 104031 Fitting Pin Ø 21 x 120
- 1 pc 715585 Pin Ø 25 x 240, SKS, galv.

Art no.	Weight [kg]	
114113	2.030	COVER MAT RCS 70X70

Elastic covering for the area of the climbing shoe for use as climbing protection panel.

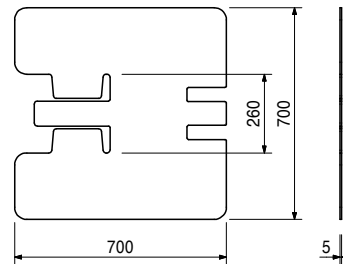
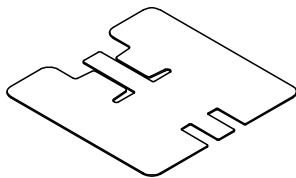

Art no.	Weight [kg]	
114947	12.600	SLAB ANCHOR TEMPLATE RCS 61

For positioning the Advancing Bolt M24 for the Slab Shoe RCS. Fixed on the stopend formwork.

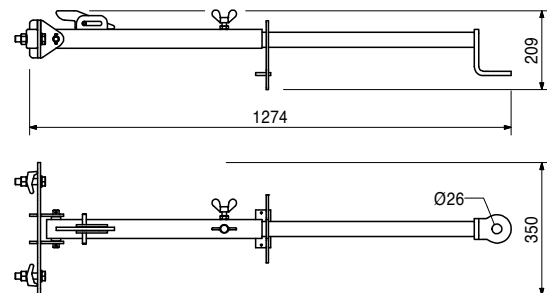
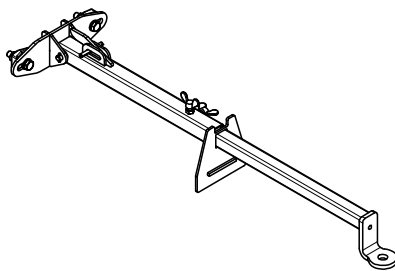

Accessory (not included)

029270	0.331	ADVANCING SCREW M 24, GALV.
--------	-------	------------------------------------

Consists of

- 1 pc 112815 Clamping Plate M16 Nova Grip
- 1 pc 115112 Wing-Bolt DIN 316 M12 x 25-GT, galv.
- 1 pc 710229 Nut ISO 4032 M16-8, galv.
- 1 pc 711074 Washer ISO 7089 200 HV, A 16, galv.
- 1 pc 714093 Bolt ISO 4014 M16 x 70-8.8, galv.

RCS-P

Art no.	Weight [kg]	
029270	0.331	ADVANCING SCREW M 24, GALV.

For fixing the Anchor System M24 if the plywood formlining has been drilled through.

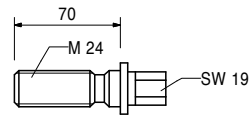
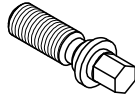

Accessory (not included)

029280	0.196	ANCHOR POSIT. PLATE M24, GALV.
--------	-------	---------------------------------------

Art no.	Weight [kg]	
115918	9.380	SLAB SHOE ADAPTER RCS/AV/SLS

Mounted on the Slab Shoe RCS and serves for connecting Kicker AV or SLS Spindles and Bracing DW 15.

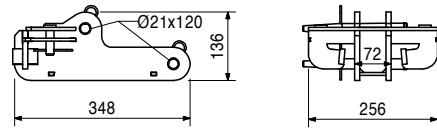
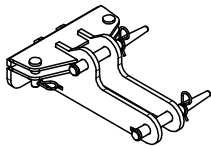

Consists of

- 4 pc 018060 Cotter Pin 4/1, galv.
- 2 pc 027170 Pin Ø 16 x 42, galv.
- 2 pc 104031 Fitting Pin Ø 21 x 120

Art no.	Weight [kg]	
115850	11.200	SLAB SUPPORT ADAPTER RCS

For attaching the Climbing Shoe RCS to a slab support with horizontal Climbing Rail RCS.

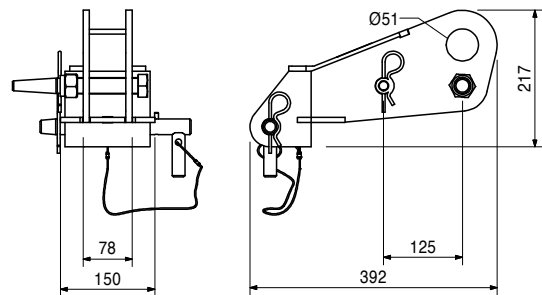
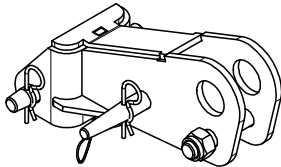

Consists of

- 2 pc 022230 Cotter Pin 5/1, galv.
- 1 pc 111567 Fitting Pin Ø 26 x 120
- 1 pc 715585 Pin Ø 25 x 240, SKS, galv.

Art no.	Weight [kg]	
112359	15.000	SLAB SUPP. ANCHOR SHOE RCS M24

Anchor System M24. For anchoring the slab support with horizontal Climbing Rail RCS.

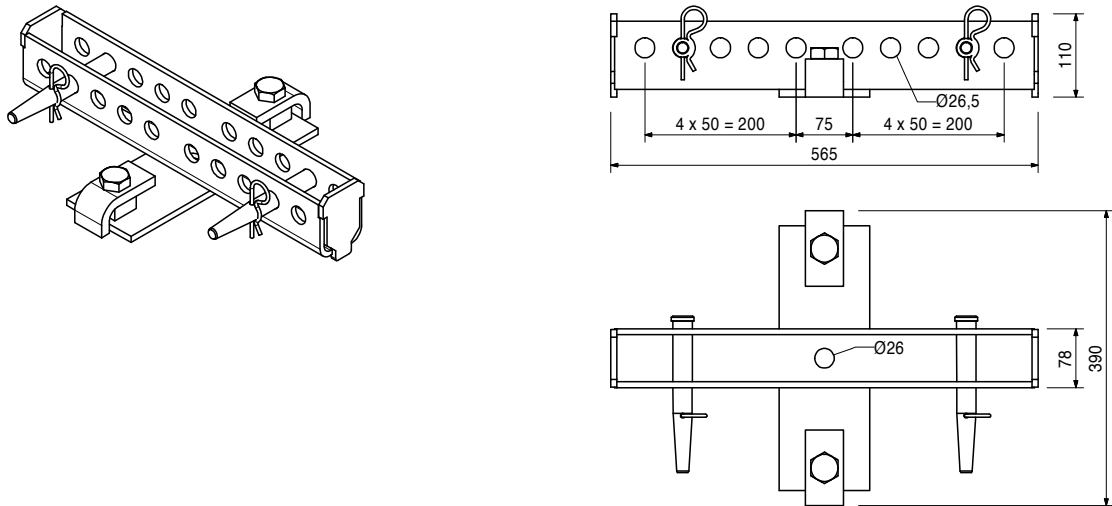

Accessory (not included)

026430	0.334	HEX BOLT ISO4014-M24X070-10.9
--------	-------	--------------------------------------

Consists of

- 2 pc 022230 Cotter Pin 5/1, galv.
- 2 pc 026290 Bolt ISO 4017 M24 x 50-10.9, galv.
- 2 pc 111567 Fitting Pin Ø 26 x 120

Art no.	Weight [kg]	
116538	6.900	SLAB SUPP. ALIGNMENT SHOE RCS

As compression point and for alignment of the slab support with horizontal Climbing Rail RCS. Fixation with the Anchor Bolt 14/20 x 130 or the anchor system M24.

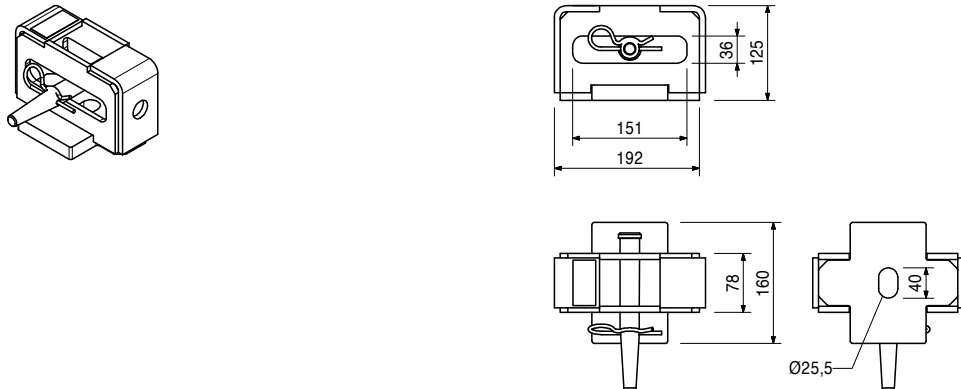

Accessory (not included)

124777	0.210	ANCHOR BOLT PERI 14/20X130
--------	-------	-----------------------------------

Consists of

- 1 pc 022230 Cotter Pin 5/1, galv.
- 1 pc 111567 Fitting Pin Ø 26 x 120

RCS-P

Art no.	Weight [kg]	
114158	1.030	SCREW-ON CONE-2 M24/DW20

Anchor System M24. For anchoring climbing systems.

Notes

Seperate design information on request.

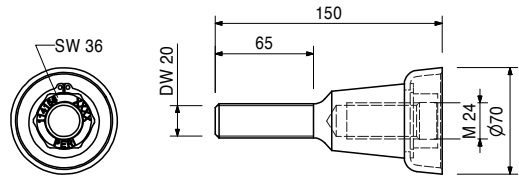
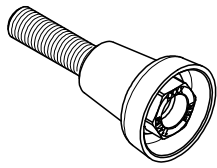

Accessory (not included)

030860	0.792	THREADED ANCHOR PLATE DW20
--------	-------	-----------------------------------

Art no.	Weight [kg]	
030860	0.792	THREADED ANCHOR PLATE DW20

For use with Tie Rod DW 20, B 20 or Screw-On Cone-2 M24/DW 20. For anchoring in concrete.

Notes

Lost anchor component.

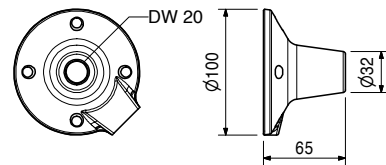
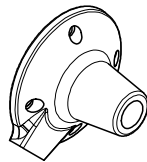

Art no.	Weight [kg]	
031220	1.010	CLIMBING CONE-2 M24/DW15

Anchor System M24. For anchoring climbing systems.

Notes

Seperate design information on request.

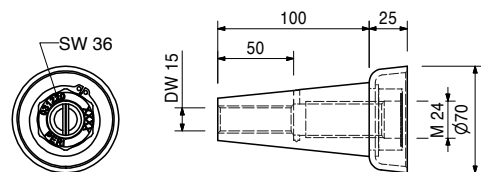
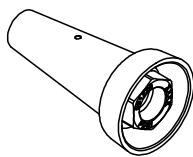

Accessory (not included)

030030	1.440	TIE ROD DW15 SPEC LENGTH
030740	1.550	TIE ROD B15 SPEC LENGTH
030840	0.515	THREADED PLATE DW15

RCS-P

Art no.	Weight [kg]	
030840	0.515	THREADED PLATE DW15

For use with Tie Rod DW 15 or B 15. For anchoring in concrete.

Notes

Lost anchor part.

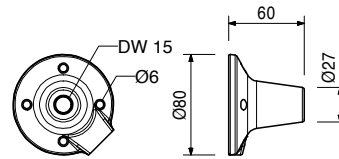
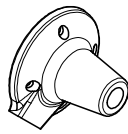

Art no.	Weight [kg]	
		Tie Rod DW 15
030050	0.000	TIE ROD DW15 CUTTING COST
030030	1.440	TIE ROD DW15 SPEC LENGTH

Notes

Non-weldable! Observe the permissions! Permissible tension force 90 kN.

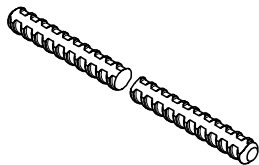

Art no.	Weight [kg]	
		Tie Rod B 15
030740	1.550	TIE ROD B15 SPEC LENGTH
030050	0.000	TIE ROD DW15 CUTTING COST

Notes

Weldable! Observe the permissions! Permissible tension force 85 kN.

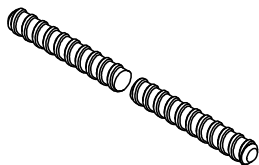

Art no.	Weight [kg]		L [mm]
026430	0.334	HEX BOLT ISO4014-M24X070-10.9	70

High-strength bolt for anchoring climbing systems.

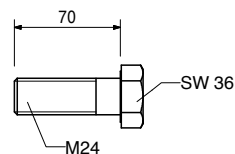
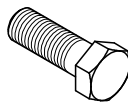

RCS-P

Art no.	Weight [kg]	
113232	10.500	STOPEND SLAB SHOE RCS, M30

For anchoring the Climbing Shoe RCS at the front end of the slab. Anchor System M30. With the Reduction Bush $\varnothing 30 - 25$, Item no. 113822, also usable with Anchor System M24.

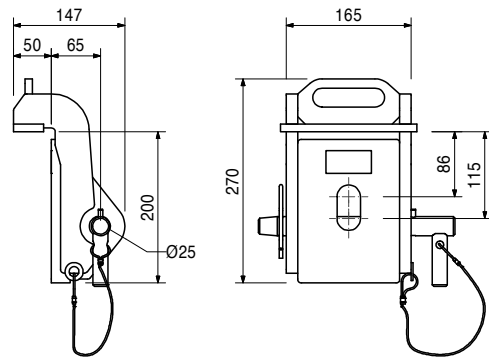
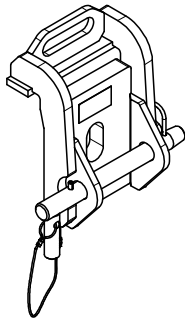

Accessory (not included)

029420	0.590	HEX BOLT ISO4017-M30X070-8.8VZ
--------	-------	---------------------------------------

Consists of

- 1 pc 022230 Cotter Pin 5/1, galv.
- 1 pc 113247 Pin $\varnothing 25 \times 260$, mont.

Art no.	Weight [kg]	
113822	0.108	REDUCING SLEEVE D=30-D=25

For using Stopend Slab Anchor M24/20-128 on the Stopend Slab Shoe RCS.

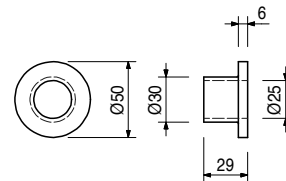

Accessory (not included)

026430	0.334	HEX BOLT ISO4014-M24X070-10.9
--------	-------	--------------------------------------

Art no.	Weight [kg]	
113820	3.450	STOPEND SLAB ANCHOR M24/20-128

Anchor System M24 or M30 for transferring clear tension forces into the slab with the use of Slab Stopend Shoe RCS. Inclusive Positioning Plate M24 (grey) or M30 (red).

Notes

Separate design information on request.

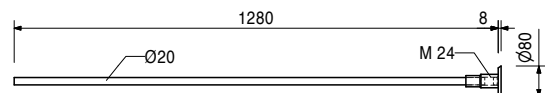
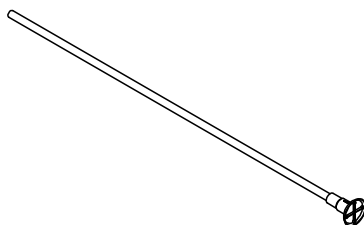

RCS-P

Art no.	Weight [kg]	
113821	6.700	STOPEND SLAB ANCHOR M30/25-160

Tie System M24 or M30 for transferring clear tension forces into the slab with the use of Front Slab Shoe RCS. With Steck-teller M24 (grey) and M30 (red).

Notes

Permissible load: see PERI product information.

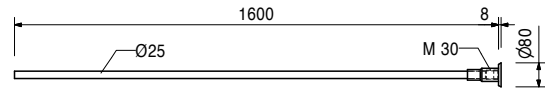
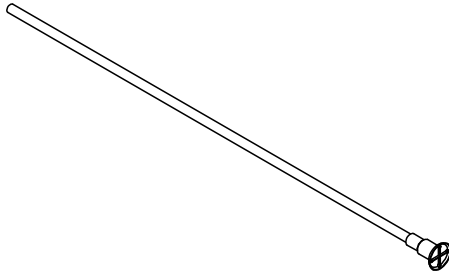

Art no.	Weight [kg]	
114997	7.160	BRACING SHOE RCS DW15

For anchoring the bracing with DW 15 to the building slab. Fixation with Anchor System M24 or corresponding dowels.

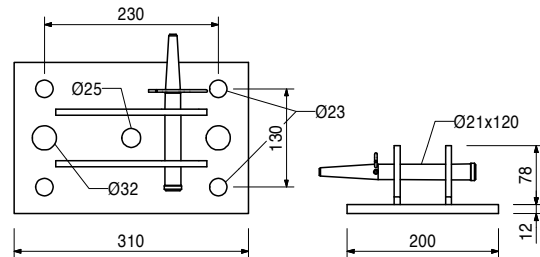
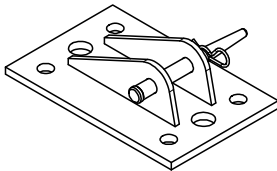

Consists of

- 1 pc 018060 Cotter Pin 4/1, galv.
- 1 pc 104031 Fitting Pin Ø 21 x 120

Art no.	Weight [kg]	
115375	6.100	ARTICULATED SPANNER RCS DW

For tensioning and as an articulated connection to the Climbing Rail RCS, Steel Waler SRU or Bracing Shoe RCS for bracing with DW 15.

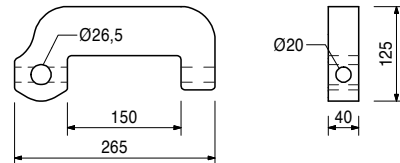
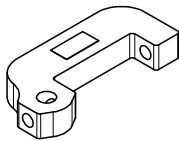

Accessory (not included)

018060	0.014	COTTER PIN 4/1, GALV.
022230	0.033	COTTER PIN 5/1, GALV.
030030	1.440	TIE ROD DW15 SPEC LENGTH
030070	0.222	HEX NUT DW15 SW 30/50, GALV.
104031	0.462	FILLER PIN D=21X120
111567	0.729	PIN D=26X120

RCS-P

Art no.	Weight [kg]	
115378	1.080	EYE NUT RCS DW15

As an articulated connection to the Climbing Rail RCS, Steel Waler SRU for bracing with DW 15.

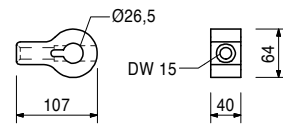

Accessory (not included)

018060	0.014	COTTER PIN 4/1, GALV.
022230	0.033	COTTER PIN 5/1, GALV.
104031	0.462	FILLER PIN D=21X120
111567	0.729	PIN D=26X120

Art no.	Weight [kg]	
115388	1.910	FORKHEAD ADAPTER RCS/SLS

For horizontal bracing of the climbing protection panel against the Slab Stopend Shoe RCS with a Heavy Duty Spindle SLS.

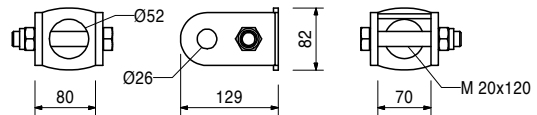
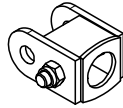

Consists of

- 1 pc 104477 Bolt ISO 4014 M20 x 120-8.8, galv.
- 1 pc 781053 Nut ISO 7040 M20-8, galv.

Art no.	Weight [kg]	
115298	4.210	SPINDLE SHOE SLS/RCS M24

For horizontal bracing of the climbing protection panel against the Advancing Anchor M24 with a Heavy Duty Spindle SLS.

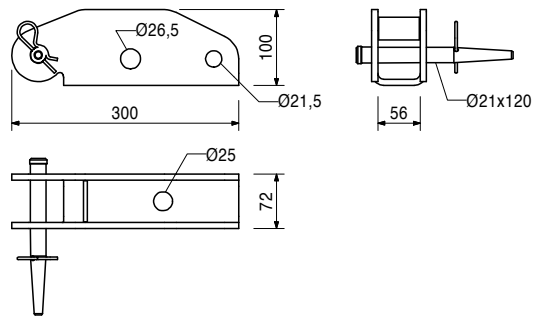
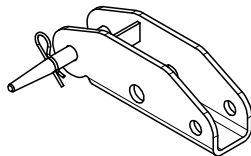

Accessory (not included)

104031	0.462	FILLER PIN D=21X120
111567	0.729	PIN D=26X120

Consists of

- 1 pc 018060 Cotter Pin 4/1, galv.
- 1 pc 104031 Fitting Pin Ø 21 x 120

RCS-P

Art no.	Weight [kg]	
109765	27.000	CLIMBING DEVICE RCS 50

For crane-independent climbing of RCS Climbing Units.

Notes

Follow Instructions for Use.
Maximum lifting capacity 50 kN.

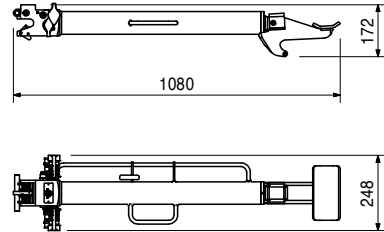
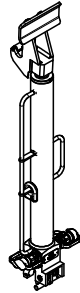

Art no.	Weight [kg]	
109766	109.000	HYDRAULIC PUMP RCS 4-FOLD

Hydraulic pump for actuating the Climbing Device RCS 50 and LPS 30.

Notes

Follow Instructions for Use.
Use only original PERI Hydraulic Oil HV LP46.

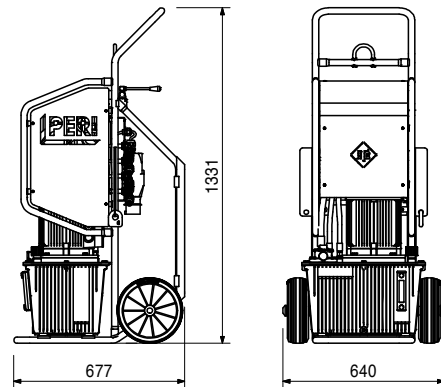
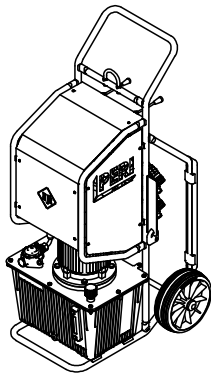

Accessory (not included)

057376	18.300	HYDR.FLUID ISO11158 HVI46, 20L
--------	--------	---------------------------------------

Art no.	Weight [kg]	
057376	18.300	HYDR.FLUID ISO11158 HVI46, 20L

High-quality synthetic hydraulic oils for PERI Hydraulic Power Units with different viscosity suitable for certain temperature ranges.

Notes

Filter with filter pump before filling the aggregates.
Observe Safety Data Sheet and applicable National Safety Regulations regarding hydraulic oil, in particular for transport, storage and disposal! Observe the technical documentation for the hydraulic power unit! Product Data Sheet on request.

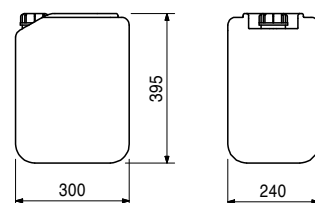

RCS-P

Art no.	Weight [kg]	
		Hydraulic Twin Hoses RCS
110069	8.500	HYDRAULIC TWIN HOSE RCS 10M
110070	15.300	HYDRAULIC TWIN HOSE RCS 20M

Two permanently connected hydraulic hoses for connecting hydraulic pumps with hydraulic climbing devices.

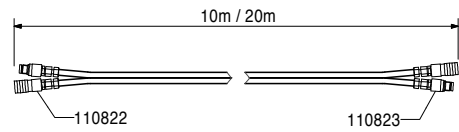
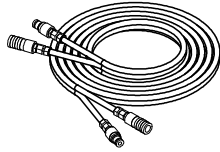

Consists of

- 4 pc 051750 Male Stud Coupler X-GE12PSR-ED
- 2 pc 128992 Pin ISO16028 DN10 R3/8IG
- 2 pc 128993 Sleeve ISO16028 DN10 R3/8IG

Art no.	Weight [kg]	
110280	0.500	ADAPTER CABLE RCS

For the power supply to the Hydraulic Pump RCS.

Notes

Follow Instructions for Use!
With CEE plug connector 400 V 16 A.

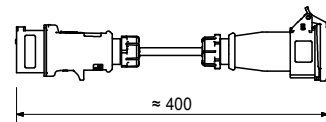
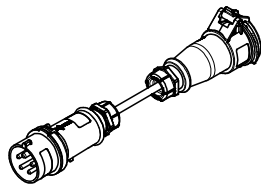

Art no.	Weight [kg]	
110279	0.291	PLUG SOCKET RCS, BLACK

For providing the power supply to the Hydraulic Pump RCS with 380 – 460 V, 50 – 60 Hz.

Notes

Follow Instructions for Use!

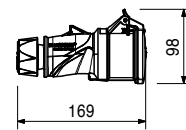

Art no.	Weight [kg]		L [mm]
072180	0.560	RATCHET WRENCH 1/2 "	300

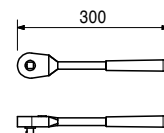
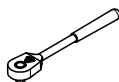

RCS-P

Art no.	Weight [kg]		L [mm]
051764	2.650	RATCHET WRENCH 3/4"	630

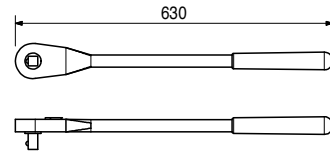
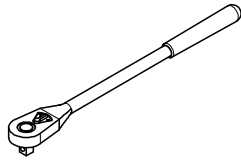

Art no.	Weight [kg]		L [mm]
029610	5.300	RATCHET WRENCH 1" L=815MM	900

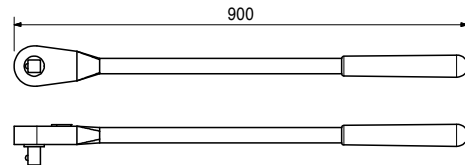
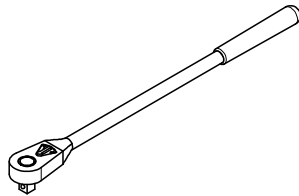

Art no.	Weight [kg]	
029620	0.075	SOCKET SW 19-1/2"

Fits to Hex. Bolts M12 or Height Adjusting Unit SW 19.

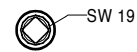

Art no.	Weight [kg]	
057276	0.625	SOCKET SW30 - 3/4"

Fits to Hex. Bolts M12 or Height Adjusting Unit SW 30.

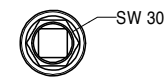
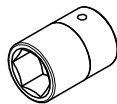

Art no.	Weight [kg]	
102785	0.452	SOCKET SW 36-3/4"

Fits to Hex. Bolts M12 or Height Adjusting Unit SW 36.

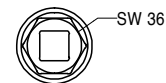
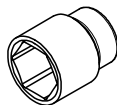

Art no.	Weight [kg]	
029630	0.580	SOCKET SW 46-1"

Fits to Hex. Bolts M12 or Height Adjusting Unit SW 46.

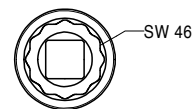
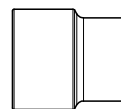
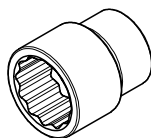

Art no.	Weight [kg]		L [mm]
		Climbing Rail Profile RCS	
116478	37.000	CLIMBING RAIL PROFILE RCS 148	1480
116479	61.500	CLIMBING RAIL PROFILE RCS 248	2480
116480	86.300	CLIMBING RAIL PROFILE RCS 348	3480
113705	98.700	CLIMBING RAIL PROFILE RCS 398	3980
116481	124.000	CLIMBING RAIL PROFILE RCS 498	4980
116482	186.000	CLIMBING RAIL PROFILE RCS 748	7480
116483	248.000	CLIMBING RAIL PROFILE RCS 998	9980
117585	24.300	CLIMBING RAIL RCS 98	980

Steel profile for all-purpose use of climbing application or civil constructions. Single profile.

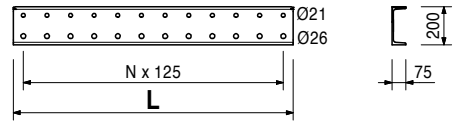
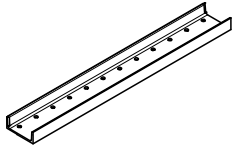

Accessory (not included)

110022	0.491	SPACER M20-82
110023	0.910	SPACER M24-82

RCS-P

Art no.	Weight [kg]	
115581	10.280	SERVICE BOX HYDRAULICS

Consisting of:

- 1 pc. 115590 Tool Box 580 x 260 x 285 mm
- 6 pc. 115583 Pressure Gauge Typ 570 VA-Geh.
- 6 pc. 115584 Hose MKT 6-02 DN 02
- 12 pc. 115582 Measuring Coupl. SMK 20-G 1/4-PC
- 2 pc. 115591 Double Spanner SW 10 x 13
- 1 pc. 115592 Double Spanner SW 13 x 17
- 1 pc. 115588 Double Spanner SW 19 x 24
- 1 pc. 051778 Double Spanner SW 24 x 27
- 1 pc. 115589 Double Spanner SW 27 x 32
- 1 pc. 057278 Allen Key Set, 8 pcs.
- 1 pc. 115585 Allen Key SW 12
- 1 pc. 057279 Allen Key SW 14
- 1 pc. 057282 Pipe Wrench
- 1 pc. 115147 Angle Fitting Set PS
- 2 pc. 115396 Fitting Set PS
- 1 pc. 072180 Ratchet Wrench 1/2"
- 20 pc. 123881 Tube Screw Plug ROV12SX
- 20 pc. 123880 Threaded Plug VKAN 12S VIT
- 100 pc. 051760 Cable Binder NT-240H
- 2 pc. 126425 Distance Piece Ø 120
- 1 pc. 126440 Socket SW 17 - 1/2"
- 1 pc. 135172 Double Spanner SW 19 x 22
- 1 pc. 135173 Allen Key SHR-Bit SW 05
- 1 pc. 135174 Allen Key SHR-Bit SW 06
- 1 pc. 135175 Allen Key SHR-Bit SW 08
- 1 pc. 135176 Allen Key SHR-Bit SW 10
- 1 pc. 135177 SHR Screwdriver Bit 6 TI. Slot/PH
- 2 pc. 711035 Adhesive Label 128 x 65 mm
- 1 pc. 126434 List of contents Hydraulic Service Case

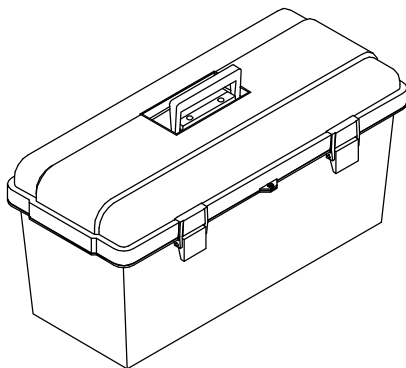

Art no.	Weight [kg]	
125632	0.050	PROT. COVERS CLIMB. DEVICE RCS

Spare part.

To protect unplugged quick couplings against dirt and damage.

Notes

Use with hydraulic hoses with FF couplings possible.

1 set for 1 Climbing Device RCS 50 (2x bushing and 2x nipple each).

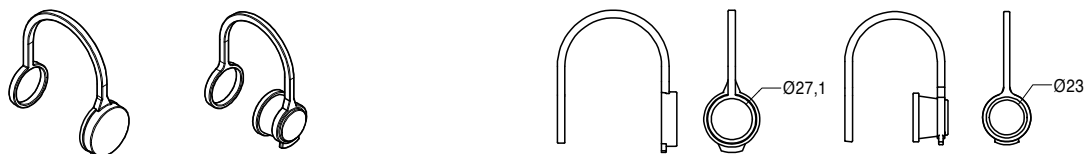

Art no.	Weight [kg]	
110823	0.171	QUICK COUPLER NIPPLE RCS

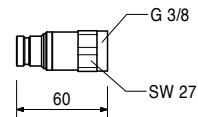

Art no.	Weight [kg]	
110822	0.297	QUICK COUPLER BUSHING RCS

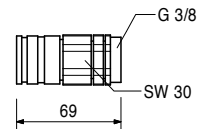
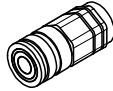

Art no.	Weight [kg]	
115147	0.750	FITTING-SET PS ANGLE

Conversion set for 1 cylinder (item-no. 109765 Climbing Device RCS50) to arrange quick couplers vertically on one side.

Notes

consisting of:

- 2 pc. Screw Plug K006.080
- 2 pc. Angle Screwing K018.740
- 2 pc. Screwing K018.294
- 1 pc. Hose Safety Device 109.063G.00.015

Art no.	Weight [kg]	
115396	0.720	FITTING-SET PS SHORT RCS

Spare fitting set for 1 cylinder (item-no. 109765 Climbing Device RCS 50) for Quick Coupler Bushings and Nipples.

Notes

consisting of:

- 4 pc. Screwing G 3/8 - G 3/8
- 2 pc. Dust Cover Nipple
- 2 pc. Dust Cover Bushing

Art no.	Weight [kg]		L [mm]
Formwork Girder GT 24			
075100	5.300	GIRDER GT 24, 90	918
075120	7.100	GIRDER GT 24, 120	1214
075150	8.900	GIRDER GT 24, 150	1510
075180	10.600	GIRDER GT 24, 180	1806
075210	12.400	GIRDER GT 24, 210	2102
075240	14.200	GIRDER GT 24, 240	2398
075270	15.900	GIRDER GT 24, 270	2694
075300	17.700	GIRDER GT 24, 300	2990
075330	19.500	GIRDER GT 24, 330	3286
075360	21.200	GIRDER GT 24, 360	3582
075390	23.000	GIRDER GT 24, 390	3878
075420	24.800	GIRDER GT 24, 420	4174
075450	26.600	GIRDER GT 24, 450	4470
075480	28.300	GIRDER GT 24, 480	4766
075510	30.100	GIRDER GT 24, 510	5062
075540	31.900	GIRDER GT 24, 540	5358
075570	33.600	GIRDER GT 24, 570	5654
075600	35.400	GIRDER GT 24, 600	5950

Universal formwork girder made of wood.

Notes

Special lengths possible via 078xxx numbers.

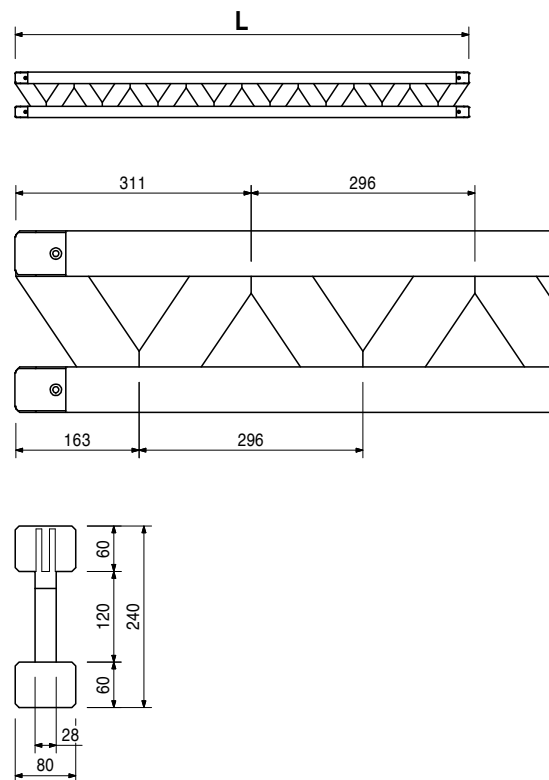
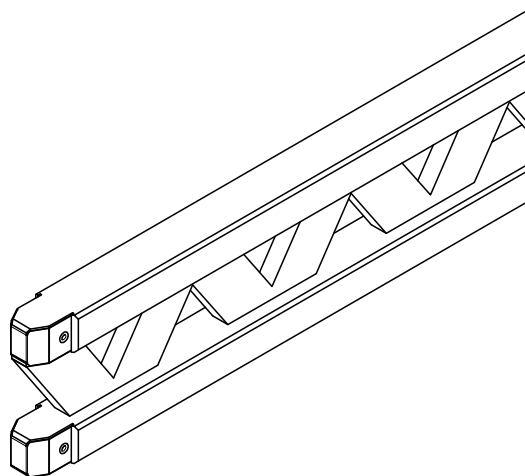

Art no.	Weight [kg]	
078010	36.875	GIRDER GT 24, 625 SPEC.LENGTH

Art no.	Weight [kg]		L [mm]
		Girder VT 20K	
074905	12.010	PERI GIRDER VT 20K 215 CM	2152
074990	8.230	PERI GIRDER VT-20K 145 CM	1447
074910	13.630	PERI GIRDER VT-20K 245 CM	2452
074890	14.710	PERI GIRDER VT-20K 265 CM	2652
074920	16.060	PERI GIRDER VT-20K 290 CM	2902
074930	18.220	PERI GIRDER VT-20K 330 CM	3292
074940	19.840	PERI GIRDER VT-20K 360 CM	3592
074950	21.460	PERI GIRDER VT-20K 390 CM	3892
074960	24.700	PERI GIRDER VT-20K 450 CM	4492
074970	26.860	PERI GIRDER VT-20K 490 CM	4902
074980	32.260	PERI GIRDER VT-20K 590 CM	5902

Universal formwork girder made of wood.

Notes

The girder fulfils all requirements of DIN EN 13377 class P20 (Declaration of Conformity).

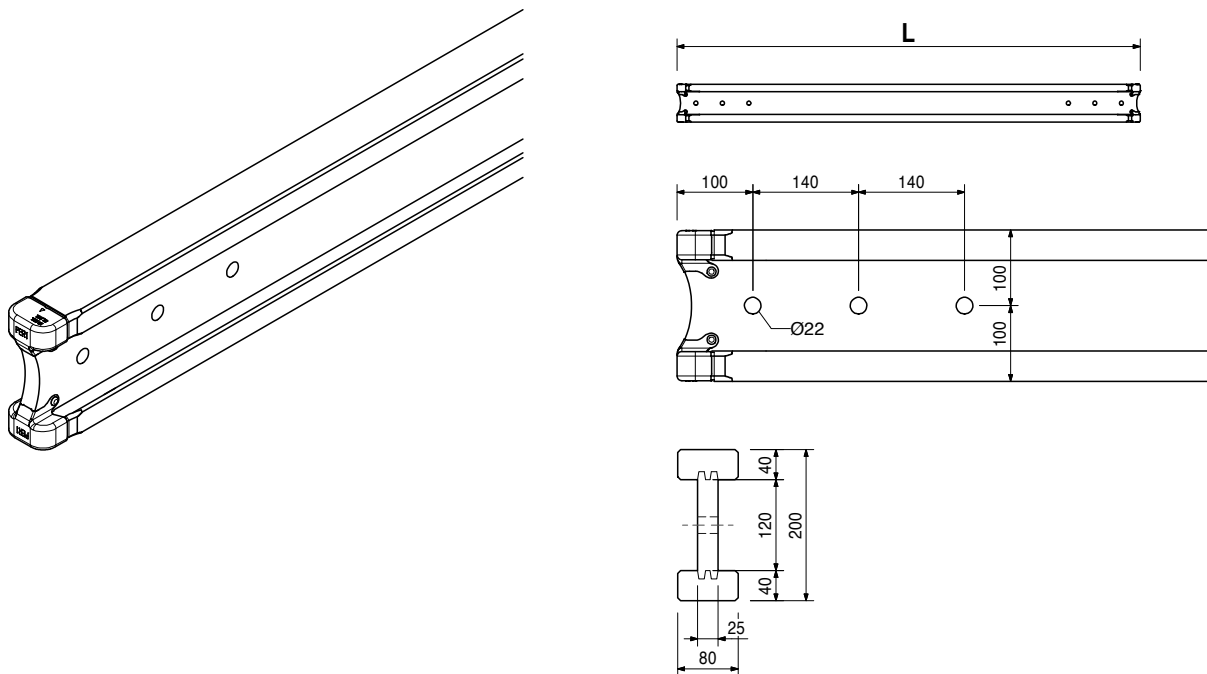

Art no.	Weight [kg]	
065068	88.300	GRATE PALLET 80X120, GALV.

For stacking and transportation of formwork and scaffold components.

Notes

Follow Instructions for Use!
 Capacity approx. 0.75 m³.
 Load-carrying capacity 1.5 t.

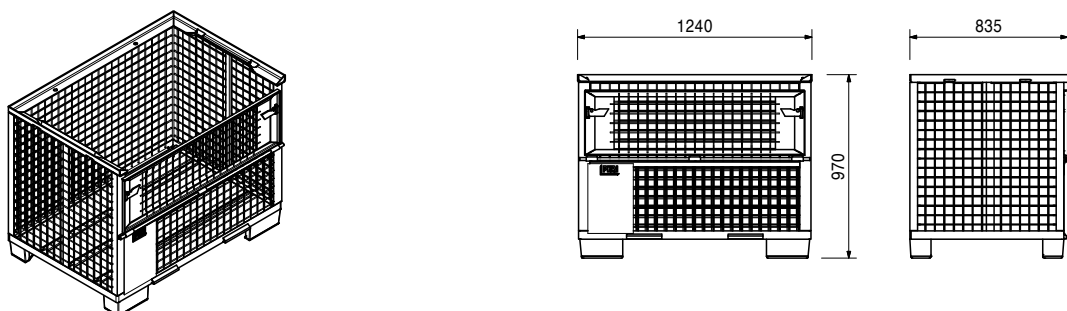

RCS-P

Art no.	Weight [kg]	
025660	66.500	HARDWARE BOX 80X120, GALV.

For stacking and transportation of formwork and scaffold components.

Notes

Follow Instructions for Use!

Capacity approx. 0.28 m³

Permissible load-bearing capacity 1.5 t.

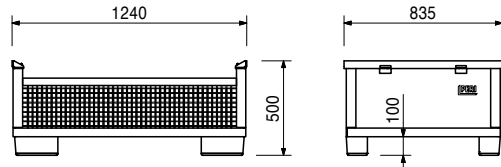
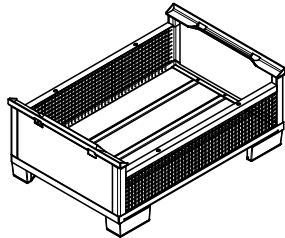

Art no.	Weight [kg]	
065067	9.410	LID FOR GRATE PALLET 80X120/K

For closing Crate Pallets 80 x 120 or Hardware Boxes 80 x 120.

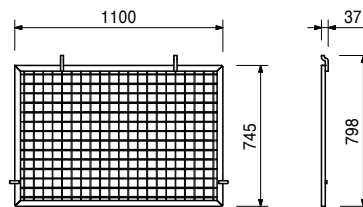
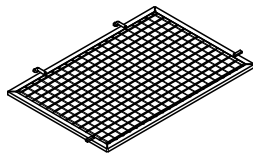

Art no.	Weight [kg]		L [mm]
		Pallet RP-2	
103434	38.500	PALLET RP 80X120/2, GALV.	1200
103429	45.300	PALLET RP 80X150/2, GALV.	1500

For stacking and transportation of formwork and scaffolding components.

Notes

Follow Instructions for Use!

Permissible load-bearing capacity 1.5 t.

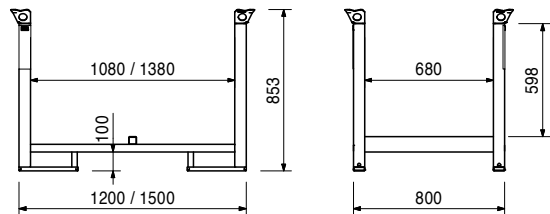
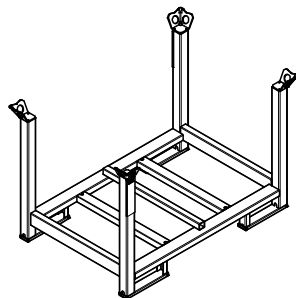

Art no.	Weight [kg]	
065015	28.000	EURO FLAT BED PALLET 800X1200

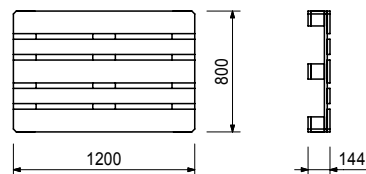
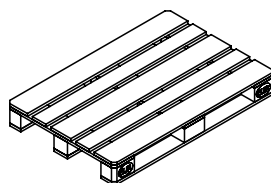

Art no.	Weight [kg]	
061510	105.000	PALLET LIFTING TRUCK 1800MM

For moving pallets and crate pallets.

Notes

Follow Instructions for Use!

Forklift arm length 1800 mm, forklift arm width 550 mm, stroke range 115 mm.

Permissible load-bearing capacity 2.0 t.

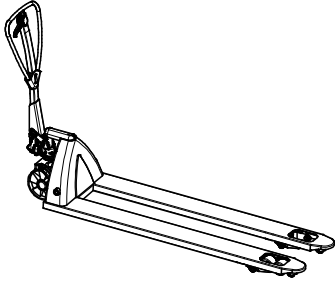

**The optimum system
for every project and
any requirement**



Wall formwork



Column formwork



Slab formwork



Climbing systems



Bridge formwork



Tunnel formwork



Shoring



Working scaffolds construction



Working scaffolds facade



Working scaffolds industry



Means of access



Safety scaffolds



Safety systems



System-independent accessories



Services



PERI Ltd
Formwork Scaffolding Engineering
 Market Harborough Road
 Clifton Upon Dunsmore
 Rugby
 CV23 0AN
 +44 (0)1788 861600
 info@peri.ltd.uk
 www.peri.ltd.uk