

# SKYDECK

## Panel Slab Formwork

Instructions for Assembly and Use – Standard Configuration – Issue 04 | 2026

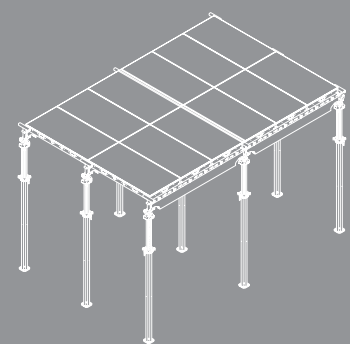

<b>Overview</b>			
Main components	4	Cantilevers (Area II)	55
Key	5	Open edge areas (Area III)	56
Presentational reference	5	Slab area (Area IV)	56
<b>Introduction</b>		Infill areas	56
Target groups	7	Platform installation	57
Additional technical documentation	7	Striking	58
Intended use	8	Working and safety scaffold	59
Cleaning and maintenance instructions	9	Platforms with SKYDECK Panels	60
Instructions on use	9	Edge protection	61
<b>Safety instructions</b>		Striking	62
Cross-system	10	A10 Changing direction	64
System-specific	11	– System with Prophead SSK	64
Storage and transportation	11	– System with Drophead SFK	66
		A11 Inclined slabs	68
Standard configuration		Bracing with Tension Sleeve SAO and Chain 3.0 kN	68
A1 Storage and transportation	12	Bracing with Tension Unit SD	69
A2 System components	15	A12 Striking	70
A3 System dimensions	18	A13 Site record	72
Notes regarding static calculations	18	<b>Design tables</b>	
Internal forces and rigidity	19	A14 Horizontal loads with Slab Props	73
Load combinations	19	A15 Inclined slabs	74
A4 Shuttering	21	Maximum permissible slab inclination with Tension Sleeve SAO and Chain 3.0 kN	74
Starting bay	21	Tension Unit SD - bracing angle	74
Transverse bay	23	Tension force of Tension Unit SD and prop loads	
Longitudinal bay	24	– System with Drophead SFK	75
Standard bay	25	– System with Prophead SSK	80
Shuttering with propheads	27	A16 SKYDECK standard configuration	85
A5 Compensations	28	Prop loads	
System components	28	– System with Drophead SFK	85
Edge Beam SRT-2 150, SRT-275	28	– System with Prophead SSK	86
Filler Timber SPH	28	– Panel system	87
End Support SSL	28	Striking guide values	87
Combihead SCK	29	A17 Filler plates, forming around columns	88
Triangular Frame SDR 150/75, 75/75	32	A18 Slab Props	89
Length compensations	32	– PEP 20	89
Transverse compensation	35	– PEP 20 with Base MP 50	90
A6 Shuttering around columns	38	– PEP 30	91
1 recessed panel	38	– PEP 30 with Base MP 50	92
2 recessed panels	39	– PEP Ergo B	93
3 recessed panels	40	– PEP Ergo D	94
Recessed main beams	41	– PEP Ergo E	96
Shifting the main beam axis	41	– MULTIPROP 250, 350, 480, 625	98
A7 Horizontal bracing	43	– MULTIPROP 250, 350, 480, 625 with Base MP 50	99
General	43	<b>Components</b>	
Bracing of the inner bay	43	Components	100
Transfer of horizontal loads from a casting segment	44		
A8 Cantilevers, guardrails	46		
Bracing on open building edges to prevent tipping	46		
Guardrails with Handrail Unit SD	47		
SKYDECK Guardrail Holder SGH and Guardrail Post SGP	48		
A9 SKYDECK Platforms	50		
Corner table (Area I)	51		

## Main components

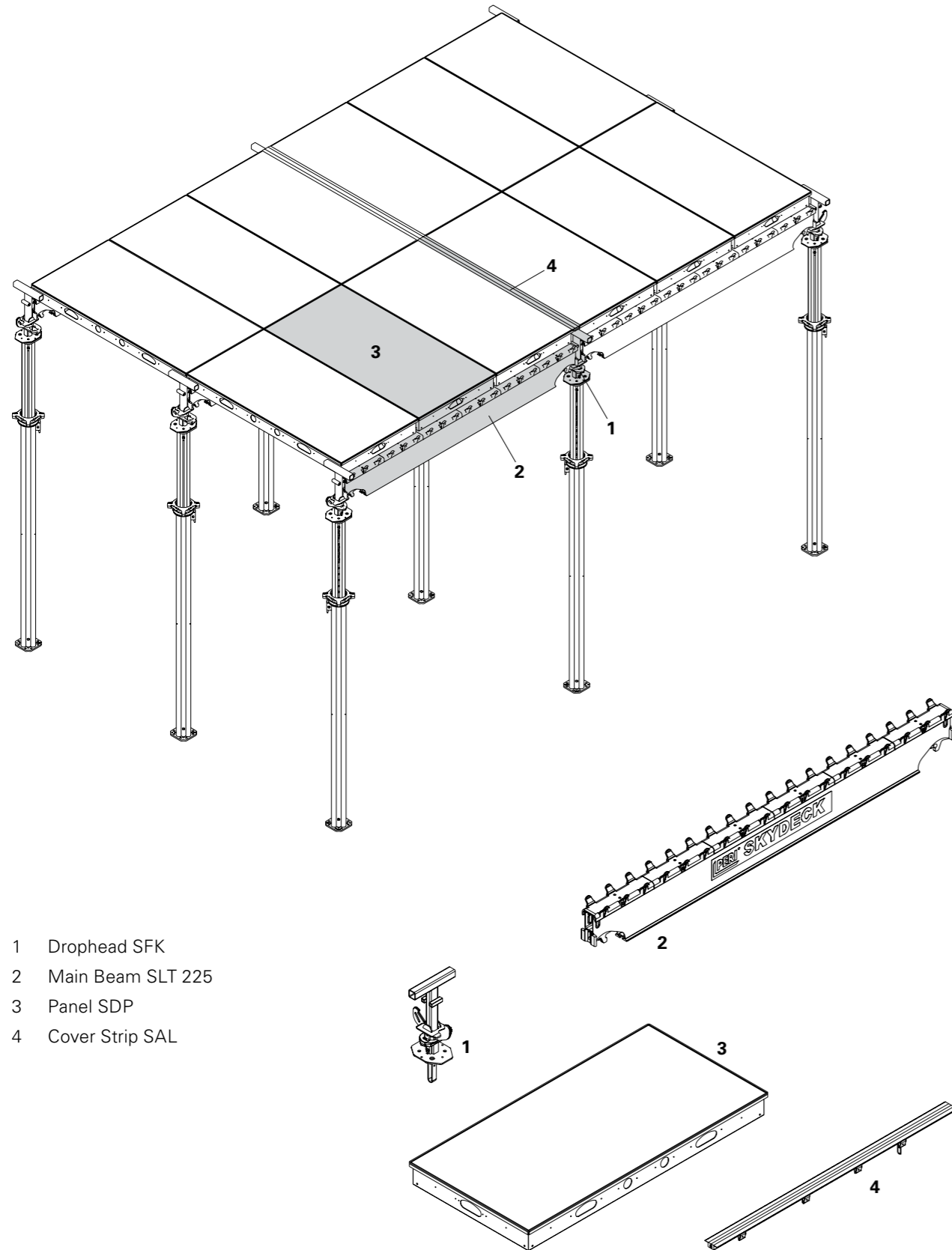

- 1 Drophead SFK
- 2 Main Beam SLT 225
- 3 Panel SDP
- 4 Cover Strip SAL

## Key

### Pictogram | Definition

- Safety instructions
- Note
- Load-bearing point
- Visual check
- Tip
- Personal protective equipment to prevent falling from a height (PPE)
- Misapplication
- Correct application

### Dimension specifications

Dimensions are usually given in cm. Other measurement units, e.g. m, are shown in the illustrations.

### Conventions

- Instructions are numbered with: 1. ...., 2. ...., 3. ....
- The result of an instruction is shown by: →
- Position numbers are clearly provided for the individual components and are given in the drawing, e.g. **1**, in the text in brackets, for example (1).
- Multiple position numbers, i.e. alternative components, are represented with a slash, e.g. **1 / 2**.

### Arrows

- Arrow representing an action
- Arrow representing a reaction of an action\*
- Forces

\* if not identical to the action arrow.

## Presentational reference

The illustration on the front cover of these instructions is understood to be a system representation only. The assembly steps presented in these Instructions for Assembly and Use are shown in the form of examples with only one component size. They are valid accordingly for all component sizes contained in the standard configuration.

For a better understanding, detailed illustrations are partly incomplete. The safety installations which have possibly not been included in these detailed drawings must nevertheless still be available.

## Target groups

### Contractors

These Instructions for Assembly and Use are designed for contractors who use the formwork systems for

- assembling, modifying and dismantling operations, or
- use them, e.g. for concreting, or
- allow them to be used for other work operations, e.g. carpentry or electrical work.

The contractor's procedures for the control of temporary works must ensure that suitably competent persons are appointed to manage the planning and use of PERI formwork systems.

The appointed person(s):

- must identify potential hazards during the planning phase,
- determines measures that provide protection against risks,
- creates a safety and health plan,
- coordinates the protective measures for the contractor and site personnel so that they do not endanger each other,
- monitors compliance with the protective measures.

### Competent persons

Due to the specialist knowledge gained from professional training, work experience and recent professional activity, the competent person has a reliable understanding of safety-related issues and can correctly carry out inspections. Depending on the complexity of the test to be undertaken, e.g. scope of testing, type of testing or the use of a certain measuring device, a range of specialist knowledge is necessary.

### Qualified persons

Formwork systems may only be assembled, modified or dismantled by personnel who are suitably qualified to do so.

For the work to be carried out, the qualified persons must have received instructions\* covering at least the following points:

- Explanation of the plan for the assembly, modification or dismantling of the formwork in an understandable form and language.
- Description of the measures for assembling, modifying or dismantling the formwork.
- Designation of the preventive measures to avoid the risk of persons and objects falling.

- Designation of the safety precautions in the event of changing weather conditions which could adversely affect the safety of the formwork system as well as the persons concerned.
- Details regarding the permissible loads.
- Description of any other risks that are associated with the assembly, modification or dismantling procedures.

\* Instructions are given by the contractor himself or a competent person selected by him.

## Additional technical documentation

- Poster: SKYDECK
- MULTIPROP Slab Props: Instructions for Assembly and Use
- PEP Ergo Slab Props: Instructions for Assembly and Use
- Instructions for Use:
  - Pallet Lifting Truck
  - Pallets and Stacking Devices
  - Stripping Cart ASW 465
  - Stripping Cart Alu
  - Transportation Fork SKYDECK SUG
- Technical Data Sheet for Anchor Bolt PERI 14/20 x 130
- PERI Design Tables - Formwork and Shoring
- Brochures:
  - SKYDECK

## Intended use

### Product description

PERI products have been designed for exclusive use in the industrial and commercial sectors by qualified users only.

PERI SKYDECK is a panel slab formwork system used for constructing slab thicknesses up to 109 cm. Depending on the slab thickness and concrete strength, the SKYDECK Drophead allows striking to take place after only 1 day: see table containing minimum concrete strength and striking guide values.

The SKYDECK Platform is a prefabricated, folding scaffold platform for use as working and safety scaffold according to DIN 4420 Part 1. Immediately after concreting, it is available as safety scaffold to provide safe and secure working conditions on rising structures.

Classification is effected in Scaffold Group 2 (useful load per surface 150 kg/m<sup>2</sup>). It is required for concreting floor slabs in skeleton construction (high-rise buildings) and for securing the open edges of the SKYDECK Slab Formwork System. A 1.30 m wide platform decking with guardrails provides safe working conditions on the slab edges.

### Features

The panels and main beams are made of aluminium which means they are very light.

Accessories for infill areas, shuttering around columns and the slab edges are also available.

Due to early striking, the panels and main beams can be used for the next concreting cycle.

Only the props with dropheads and the cover strips remain in position until the full concrete strength has been reached. On-site material requirements are therefore clearly reduced.

For supporting the SKYDECK panels, PERI MULTIPROPS or PEP Slab Props can be used.

The SKYDECK Platform consists of:

- 39 mm thick plywood decking fixed to a supporting frame,
- a folding handrail unit that is screwed to the supporting frame as a framed construction, and held by a securing lever when opened up.

The platform can be used on the slab edge as well as in the corner table area. Three lengths are available for the various applications.

SDB 150	L = 1.50 m
SDB 225	L = 2.25 m
SDB 300	L = 3.00 m

The SDB 225 Platform can also be used for side cantilevers of 75 cm to the right or left of the main beam.

The platform is assembled with the crane from the outside of the building. It is set down on the cantilevered main beams and automatically locks in position.

All steel parts are galvanized while all safety components are red powder-coated.

### Technical data

#### System dimensions With Drophead SFK, Main Beam SLT 225

- 230 x 150 cm, slab thickness max. 43 cm, as standard case presented in the Instructions for Assembly and Use
- 230 x 75 cm, slab thickness max. 90 cm
- 115 x 75 cm, slab thickness max. 109 cm with centre support

#### With Drophead SFK, Main Beam SLT 150

- 155 x 150 cm, slab thickness max. 52 cm
- 155 x 75 cm, slab thickness max. 109 cm

#### With Prophead SSK, Main Beam SLT 225

- 225 x 150 cm, slab thickness max. 43 cm
- 225 x 75 cm, slab thickness max. 90 cm
- 112.5 x 75 cm, slab thickness max. 109 cm with centre support

#### With Prophead SSK, Main Beam SLT 150

- 150 x 150 cm, slab thickness max. 55 cm
- 150 x 75 cm, slab thickness max. 109 cm

For permissible slab thicknesses and available prop loads: see PERI Design Tables.

## Cleaning and maintenance instructions

In order to maintain the value and operational readiness of the formwork materials over the long term, clean the panels after each use.

Some repair work may also be inevitable due to the tough working conditions. The following points should help to keep cleaning and maintenance costs as low as possible.

Spray the formwork on both sides with concrete release agent before each use; this allows easier and faster cleaning of the formwork. Spray the concrete release agent very thinly and evenly!

Spray the rear side of the formwork with water immediately after concreting; this avoids any time-consuming and costly cleaning operations.

When used continuously, spray the panel formlining with concrete release agent immediately after striking; then clean by means of a scraper, brush or rubber lip scraper. Important: do not clean formlining made of plywood with high-pressure equipment; this could result in the formlining being damaged.

Fix box-outs and mounting parts with double-headed nails; as a result, the nails can easily be removed later, and damage to the formlining is largely avoided.

Close all unused tie holes with plugs; this eliminates any subsequent cleaning or repair work. Tie holes accidentally blocked with concrete are freed by means of a steel pin from the formlining side.

When placing bundles of reinforcement bars or other heavy objects on horizontally-stored formwork elements, suitable support, e.g. square timbers, is to be used; as a result, impressions and damage to the formlining are largely avoided.

Internal concrete vibrators should be fitted with rubber caps if possible; as a result, any damage to the formlining is reduced if the vibrator is accidentally “inserted” between the reinforcement and formlining.

Never clean powder-coated components, e.g. elements and accessories, with a steel brush or hard metal scraper; this ensures that the powder-coating remains intact.

Use spacers for reinforcement with large-sized supports or extensive areas of support; this largely avoids impressions being formed in the formlining when under load.

Mechanical components, e.g. spindles or gear mechanisms, must be cleaned of dirt or concrete residue before and after use, and then greased with a suitable lubricant.

Provide suitable support for the components during cleaning so that no unintentional change in their position is possible.

Do not clean components suspended on a crane.

## Instructions on use

The use in a way not intended according to the Instructions for Assembly and Use, or any use deviating from the standard configuration or the intended use represents a misapplication with a potential safety risk, e.g. risk of falling.

Only PERI original components may be used. The use of other products and spare parts is not allowed.

Changes to PERI components are not permitted.

## Cross-system

### General

The contractor must ensure that the Instructions for Assembly and Use supplied by PERI are available at all times and understood by the site personnel.

These Instructions for Assembly and Use can be used as a basis for the site based Risk Assessment and Method Statement (RAMS) compiled by the contractor. They are not to be considered as a substitute for the RAMS.

Always take into consideration and comply with the safety instructions and permissible loads.

For the application and inspection of PERI products, the current safety regulations and guidelines valid in the respective countries must be observed.

Materials and working areas are to be inspected on a regular basis, especially before each use and assembly, for:

- signs of damage,
- stability and
- function.

Damaged components must be exchanged immediately on site and may no longer be used.

Safety components are to be removed only when they are no longer required.

Components provided by the contractor must conform with the characteristics required in these Instructions for Assembly and Use as well as with all valid construction guidelines and standards. Unless otherwise indicated, this applies in particular:

- Timber components: Strength Class C24 for Solid Wood according to EN 338.
- Scaffold tubes: galvanised steel tubes with minimum dimensions of  $\varnothing 48.3 \times 3.2$  mm according to EN 12811-1:2003 4.2.1.2.
- Scaffold tube couplings according to EN 74.

Deviations from the standard configuration are only permitted after a further risk assessment has been carried out by the contractor. On the basis of this risk assessment, appropriate measures for working and operational safety as well as stability are to be determined. Corresponding proof of stability can be provided by PERI on request if the risk assessment and resulting measures to be implemented are made available.

Before and after exceptional occurrences that may have an adverse effect regarding the safety of the formwork system, the contractor must immediately

- create another risk assessment, with appropriate measures for ensuring the stability of the formwork system being carried out based on the results,
- and arrange for an extraordinary inspection by a competent person. The aim of this inspection is to identify and rectify any damage in good time in order to guarantee the safe use of the formwork system.

Exceptional occurrences can include:

- accidents,
- longer periods of non-use,
- natural events, e.g. heavy rainfall, icing, heavy snowfall, storms or earthquakes.

### Assembly, modification and dismantling work

Assembly, modification or dismantling of formwork systems may only be carried out by qualified persons and under the supervision of a competent person. The qualified personnel must have received appropriate training for the work to be carried out with regard to specific risks and dangers.

On the basis of the risk assessment and Instructions for Assembly and Use, the contractor must create installation instructions in order to ensure safe assembly, modification and dismantling of the formwork system.

The contractor must ensure that the personal protective equipment required for the assembly, modification or dismantling of the system, e.g.

- safety helmet,
- safety shoes,
- safety gloves,
- safety glasses,

is available and used as intended.

If personal protective equipment against falling (PPE) is required or specified in local regulations, the contractor must determine appropriate attachment points on the basis of the risk assessment.

The personal protective equipment against falling to be used is determined by the contractor.

The contractor must

- provide safe working areas for site personnel which are to be reached through the provision of safe access ways. Areas of risk must be cordoned off and clearly marked.
- ensure the stability during all stages of construction, in particular during assembly, modification and dismantling of the formwork.
- ensure and prove that all loads can be safely transferred.
- consider use of tethering where appropriate, during assembly or dismantling of the equipment.

### Utilisation

Every contractor who uses or allows formwork systems or sections of the formwork to be used, has the responsibility for ensuring that the equipment is in good condition.

If the formwork system is used successively or at the same time by several contractors, the health and safety coordinator must point out any possible mutual hazards and all work must be then coordinated.

## System-specific

Retract components only when the concrete has sufficiently hardened and the person in charge has given the go-ahead for striking to take place.

Anchoring is to take place only if the anchorage has sufficient concrete strength.

In order to avoid an overloading of the integrated temporary props, the load-bearing capacity of the slabs, plates and beams which have already been completed must be activated. For this, a free deflection possibility of these components is required. This takes place by releasing and re-installing all existing temporary props, and is also required for formwork systems where the prop head is an integral part of the slab formwork.

The load-distributing support used, such as planking, must match the respective base. If several layers are required, planks are to be arranged crosswise.

During striking, do not tear off the formwork panels with the crane.

The existing prop loads (see Tables) must be safely transferred by means of sufficiently load-bearing slab props or shoring systems.

SKYDECK Platforms are classified in Load Class 2 (permissible load  $1.5 \text{ kN/m}^2 - 150 \text{ kg/m}^2$ ). They are available as working scaffold.

The horizontal fixed position of the slab formwork must be guaranteed. This is given with circumferential walls and pre-concreted beam walers. Otherwise, the transfer of the horizontal loads has to be guaranteed by means of other measures supplied by the contractor, e.g. bracing.

Load assumptions for horizontal loads in accordance with BS 5975.

When storing heavy items on the formwork, the load-bearing capacity must be taken into consideration.

Cantilevers may only be accessed after bracing has been mounted.

With all-round enclosed structure geometries, panels are to be fixed to the main beams by means of two Panel Clips SPK (21) each for wind speeds between  $0.033 \text{ kN/m}^2$  (26 km/h) and dynamic pressure  $0.061 \text{ kN/m}^2$  (36 km/h).

For unfavourable structure geometries or larger wind speeds, additional securing measures are to be implemented, e.g.:

- ballast,
- bracing,
- dismantling the formwork etc.

## Storage and transportation

Store and transport components ensuring that no unintentional change in their position is possible. Detach lifting accessories and slings from the lowered components only if they are in a stable position and no unintentional change is possible.

Do not drop the components.

Use PERI lifting accessories and slings as well as only those load-bearing points provided on the component.

During the moving procedure

- ensure that components are picked up and set down so that unintentional falling over, falling apart, sliding, falling down or rolling is avoided.
- no persons are allowed to remain under the suspended load.

Always guide pre-assembled scaffolding bays, scaffolding units or scaffolding sections with ropes when moving them by crane.

The access areas on the construction site must be free of obstacles and tripping hazards as well as being slip-resistant.

For transportation, the surface must have sufficient load-bearing capacity.

Use original PERI storage and transport systems, e.g. crate pallets, pallets or stacking devices.

# A1 Storage and transportation



- Follow Instructions for Use for PERI Pallets and Stacking Devices!
- Manually-created transport units must be correctly stacked and secured!
- Pallets and stacked components are to be protected against the effects of the weather, e.g. secure packed components against lifting using tension straps!
- Always attach the 4-sling lifting gear using the four load-bearing points!

## Transportation

PERI pallets and stacking devices are suitable for lifting by crane or forklift. They can also be moved with the PERI Pallet Lifting Trolley. All pallets and stacking devices can be lifted using both the longitudinal and front sides. The illustrations show examples.

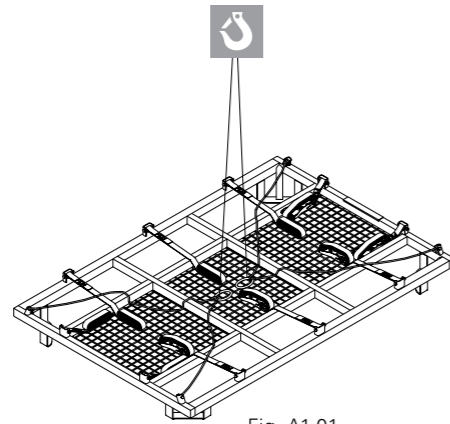

Fig. A1.01

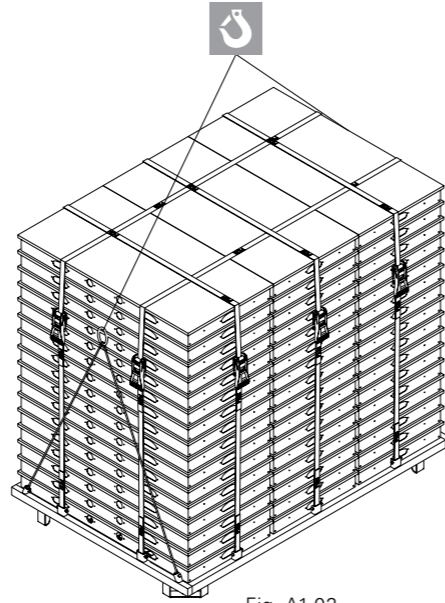

Fig. A1.02



Lashing straps are manufactured according to DIN EN 12195-2, and are to be regularly checked in accordance with this standard.

## Stacked with Panels SDP 150 x 75

Pallet SD: 48 pieces  
(Fig. A1.01 + A1.02)

Pallet SD: 14 pieces  
(Fig. A1.04 + A1.05)

The Pallet SD can also be used for storing other SKYDECK components, e.g. Main Beam SLT.  
(Fig. A1.03)

## Stacking:

2 loaded pallets, one on top of the other.

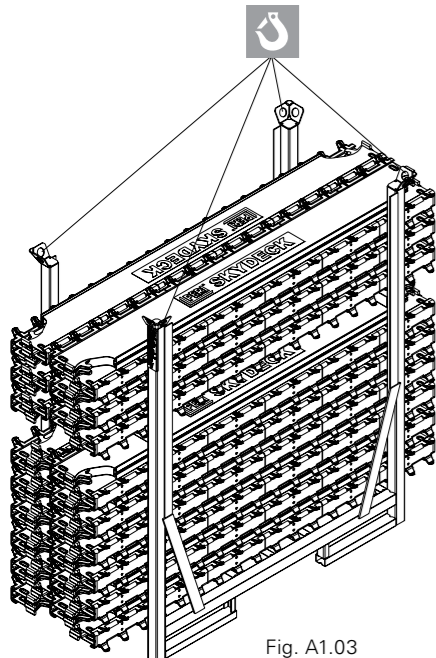

Fig. A1.03

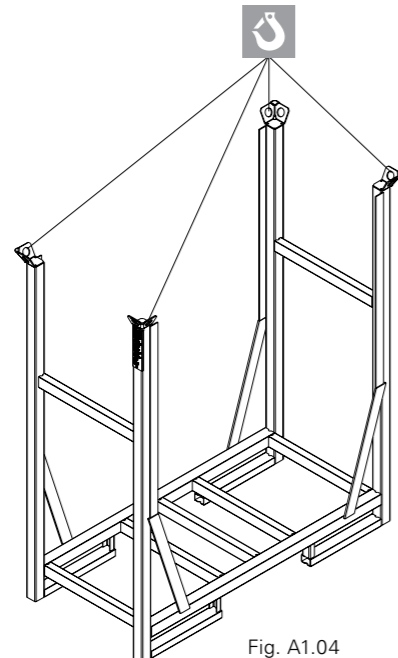

Fig. A1.04

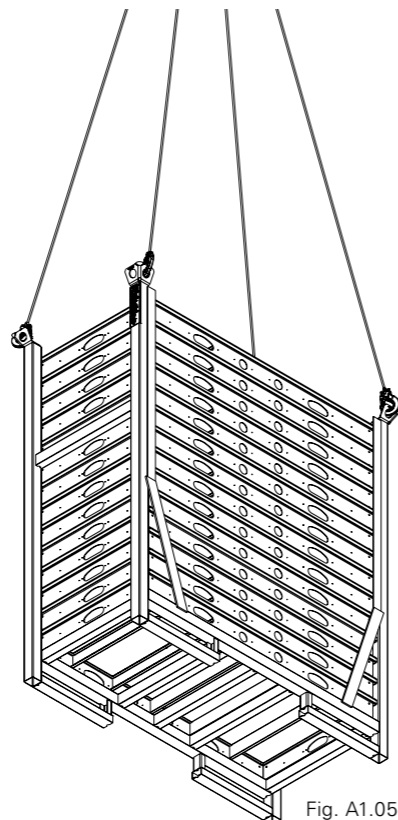

Fig. A1.05

# A1 Storage and transportation



## Pallet: Handrail Unit SD 150

## Pallet: Handrail Unit SD 75

## Number of handrail units per pallet

Handrail Unit SD 150: 10 pieces

(Fig. A1.06)

Handrail Unit SD 75: 10 pieces

(Fig. A1.07)

## Stacking:

2 loaded pallets, one on top of the other.

## Loading sequence

1. Open locking mechanism on the pallet frame.
2. Slide in one handrail unit and close locking mechanism.
3. Slide in additional handrail units. Handrail units lock automatically through the red bars.
4. Secure handrail units on the front side against sliding out. Insert retaining bar and lock in place.

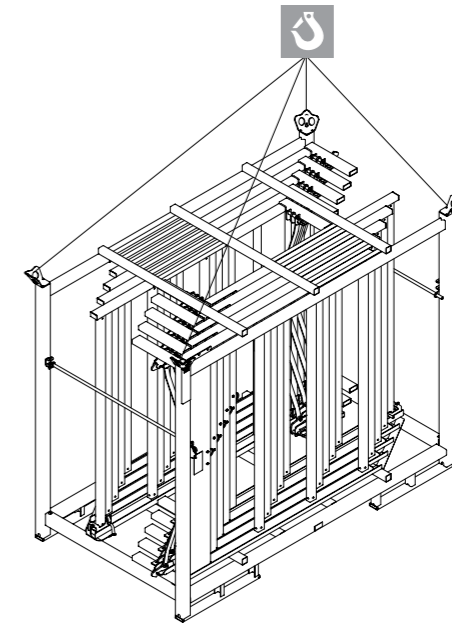

Fig. A1.06

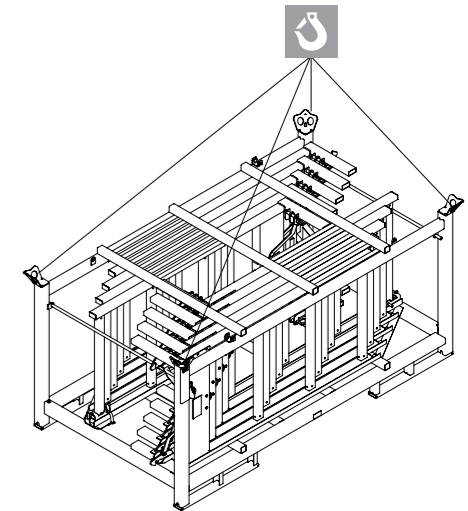

Fig. A1.07



Due to the powder coating, cleaning requirements are kept to a minimum. Panels and main beams are equipped with self-draining edges. They prevent the side areas from getting dirty and make cleaning easier.  
(Fig. A1.08)

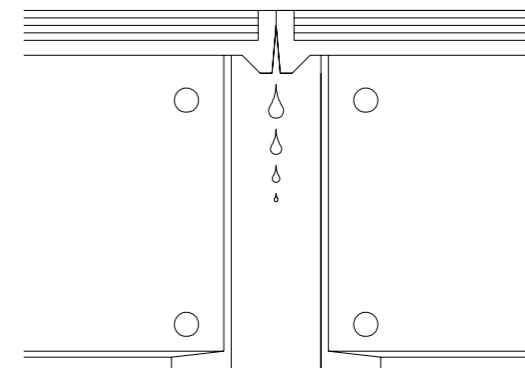

Fig. A1.08

# A1 Storage and transportation



## SKYDECK platforms

The platforms can be stored in stacks of up to 5 elements.

Weights:	
SDB 300	184 kg / piece
SDB 225	155 kg / piece
SDB 150	108 kg / piece

Stacks of platforms can be lifted with a fork-lift truck using the long side. (Fig. A1.09)

The stack can be moved with the crane by means of the external crane eyes. (Fig. A1.10)

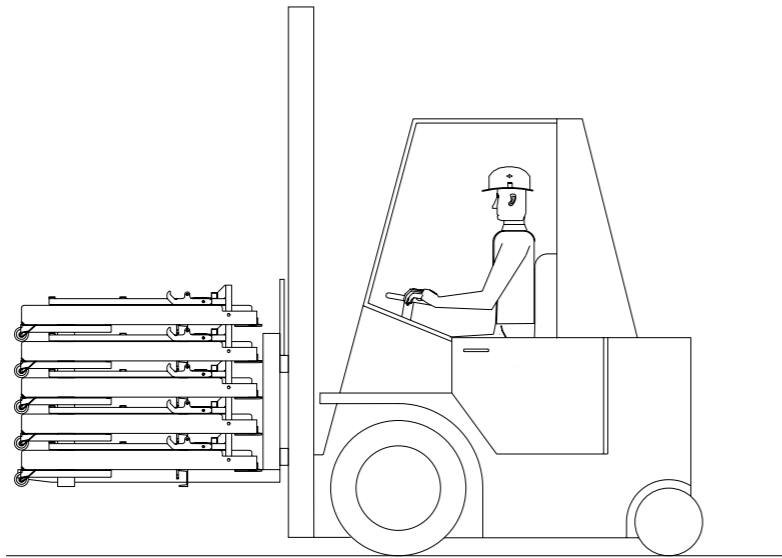

Fig. A1.09



Ensure the platforms are secured on lorries evenly but not too tightly.

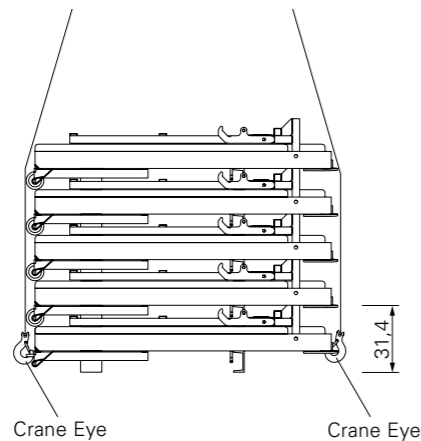

Fig. A1.10

# A2 System components



## Propheads

- Drophead SFK (1)
- Prophead SSK (6)
- Combihead SCK (7)
- Transition Head SDSK (26)
- Transition Head SDFK (27)

The Drophead SFK can be used for all standard situations and allows the removal of main beams and panels while simultaneously supporting the slab.

The Prophead SSK must be used in all starting bays. Prophead SSK and Combihead SCK are used, e.g. for compensations.

Prophead SDSK and Prophead SDFK are used when changing direction.

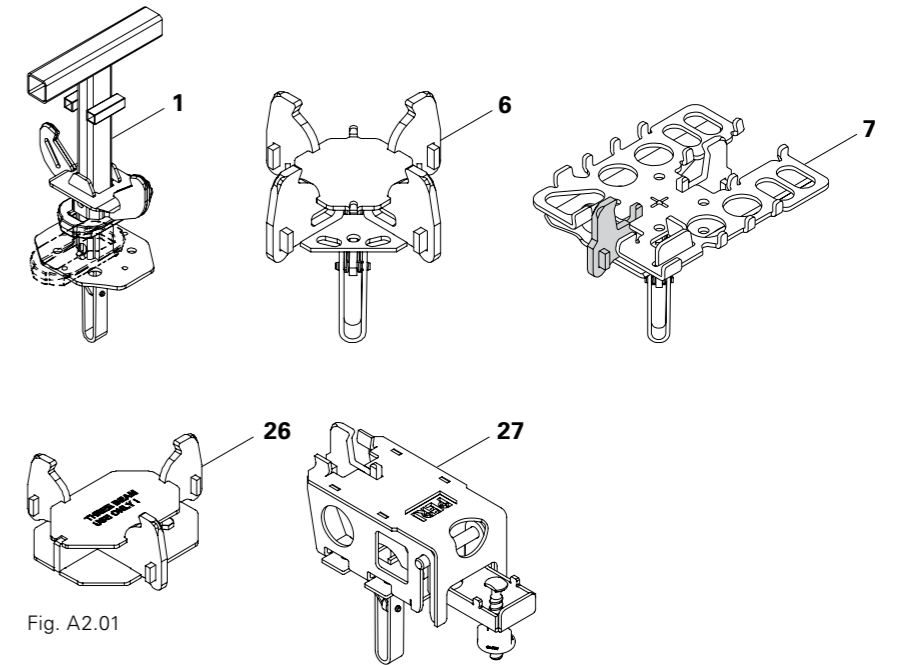

Fig. A2.01

## Main beams

- Main Beam SLT 225
- Main Beam SLT 150

For the exclusive use with the SKYDECK Platform SDB, a main beam which can accommodate the Platform SDB is available.

It may only be used for the described purposes.

- Main Beam SLT 375

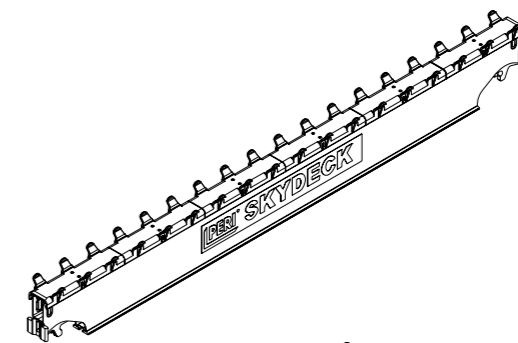

Fig. A2.02

## Panel SDP

The Panel SDP is available with the following dimensions:

- Panel SDP 150x75
- Panel SDP 150x50
- Panel SDP 150x37.5
- Panel SDP 75x75
- Panel SDP 75x50
- Panel SDP 75x37.5

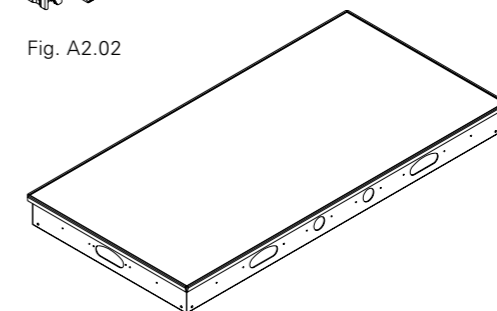

Fig. A2.03

## Cover Strip SAL

The Cover Strip SAL is available with the following dimensions:

- Cover Strip SAL 150
- Cover Strip SAL 75
- Cover Strip SAL 50
- Cover Strip SAL 37.5

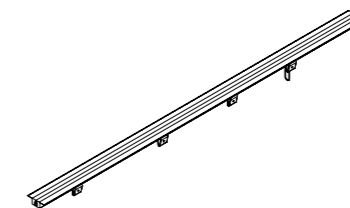

Fig. A2.04

# A2 System components



## Slab props

Dropheads SFK, Propheads SSK, SDFK or Combiheads SCK fit on props with a hole diameter of  $\varnothing 38 - 40$  mm. For hole diameters  $> 40$  mm, the heads must be bolted diagonally using 2 Bolts DIN EN ISO 4016 M12 x 40-4.6 galv., Mu, item no. 035440. (Fig. A2.01)



Transition Heads SDSK (26) must always be fitted, see A10 Changing direction



Prop loads over 33.3 kN: Drophead is bolted on for use with PEP Slab Props using 2 Bolts DIN EN ISO 4016 M12 x 40-4.6 galv., Mu.

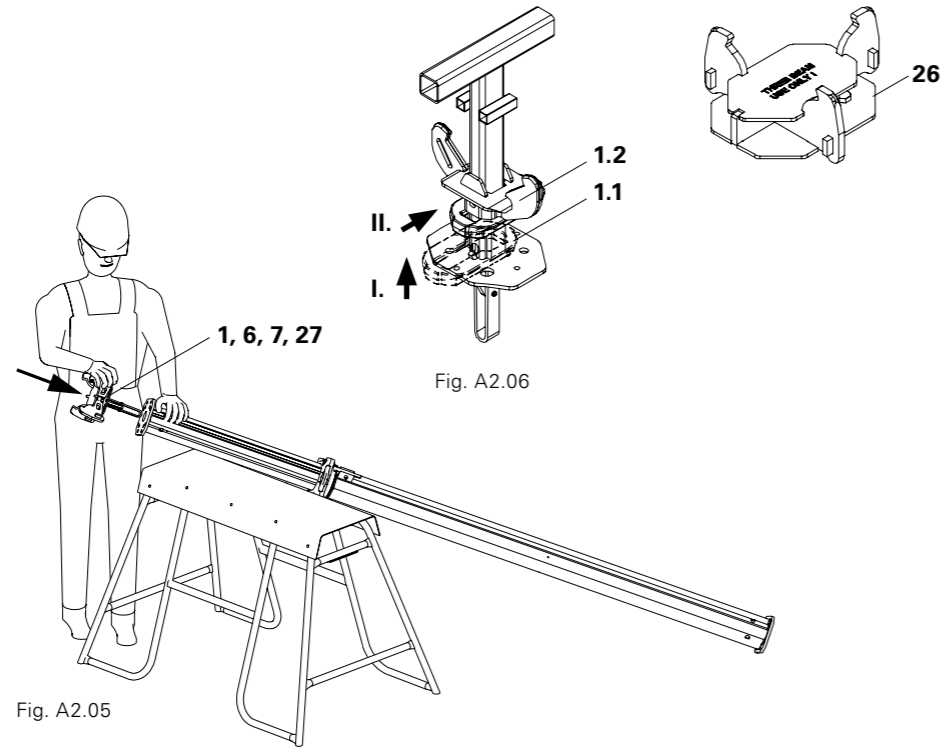

Fig. A2.05

Fig. A2.06

## Preparing the Drophead

1. Push drophead wedge (1.1) and Drophead (1.2) upwards as far as possible. (Fig. A2.06)
2. Insert drophead wedge.
3. Secure with hammer blow = shuttering position. → Drophead SFK is ready for use.

## Preparing the slab props

1. Adjust the extension lengths of the props. Clear room height minus dimension  $x$ . (Fig. A2.07). Take into consideration the different overall heights of the main beams: Main Beam SLT 225 = 24 cm / Main Beam SLT 150 = 19 cm
2. Insert the prepared Drophead (1), Prophead (6) or Combihead (7) into the prop. The self-locking coupling is secured automatically. (Fig. A2.05) → The prop is ready for use.

### Starting bay

Main Beam SLT 225

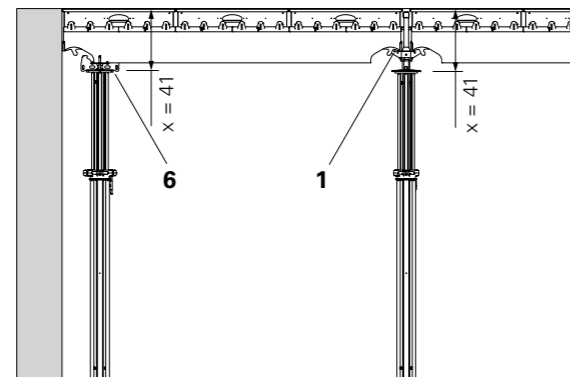

### End bay

Main Beam SLT 225

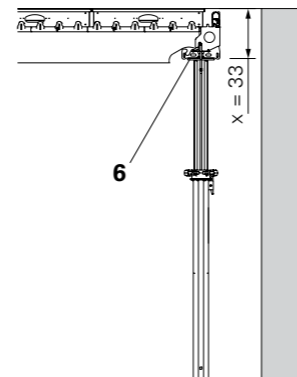

### Starting bay

Main Beam SLT 150

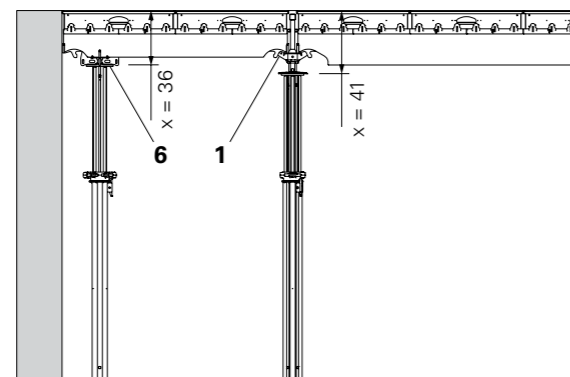

### End bay

Panel SDP

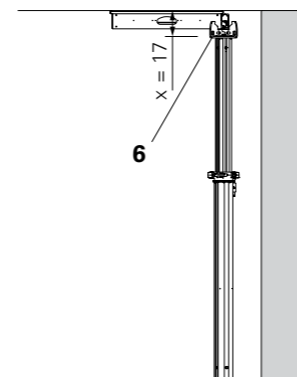

Fig. A2.07

# A2 System components



## SKYDECK Platforms SDB

SKYDECK Platform SDB 150  
SKYDECK Platform SDB 225  
SKYDECK Platform SDB 300

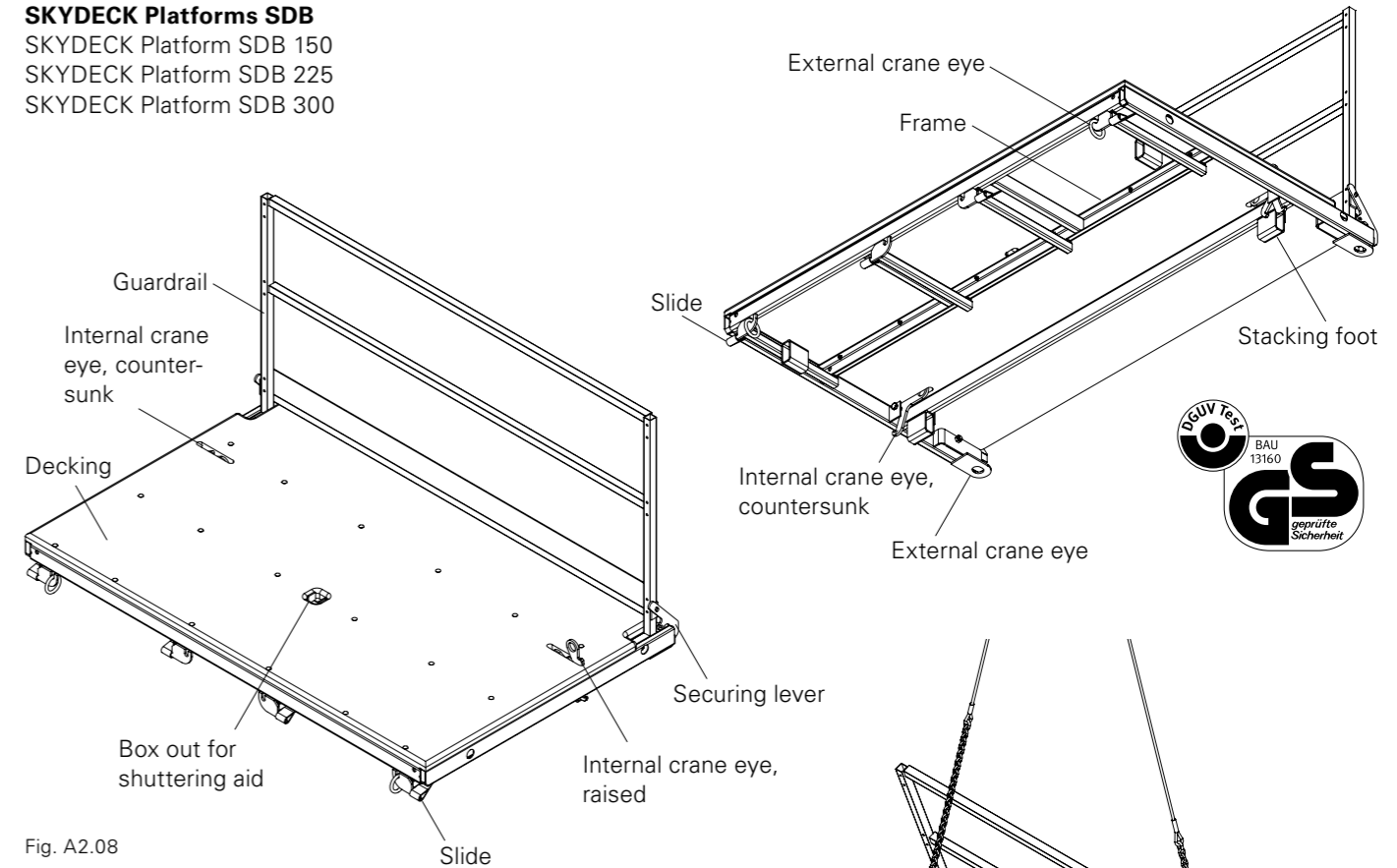

Fig. A2.08

## Preparation for use:

Take individual platforms from the stack, fold open the handrail, the securing lever drops down and secures it in a vertical position. (Fig. A2.09)



Is the securing lever engaged? Otherwise it may be necessary to secure this by hand.

For transportation by crane, the platform is attached to the concealed crane eyes with the two-sling lifting gear. (Fig. A2.10)

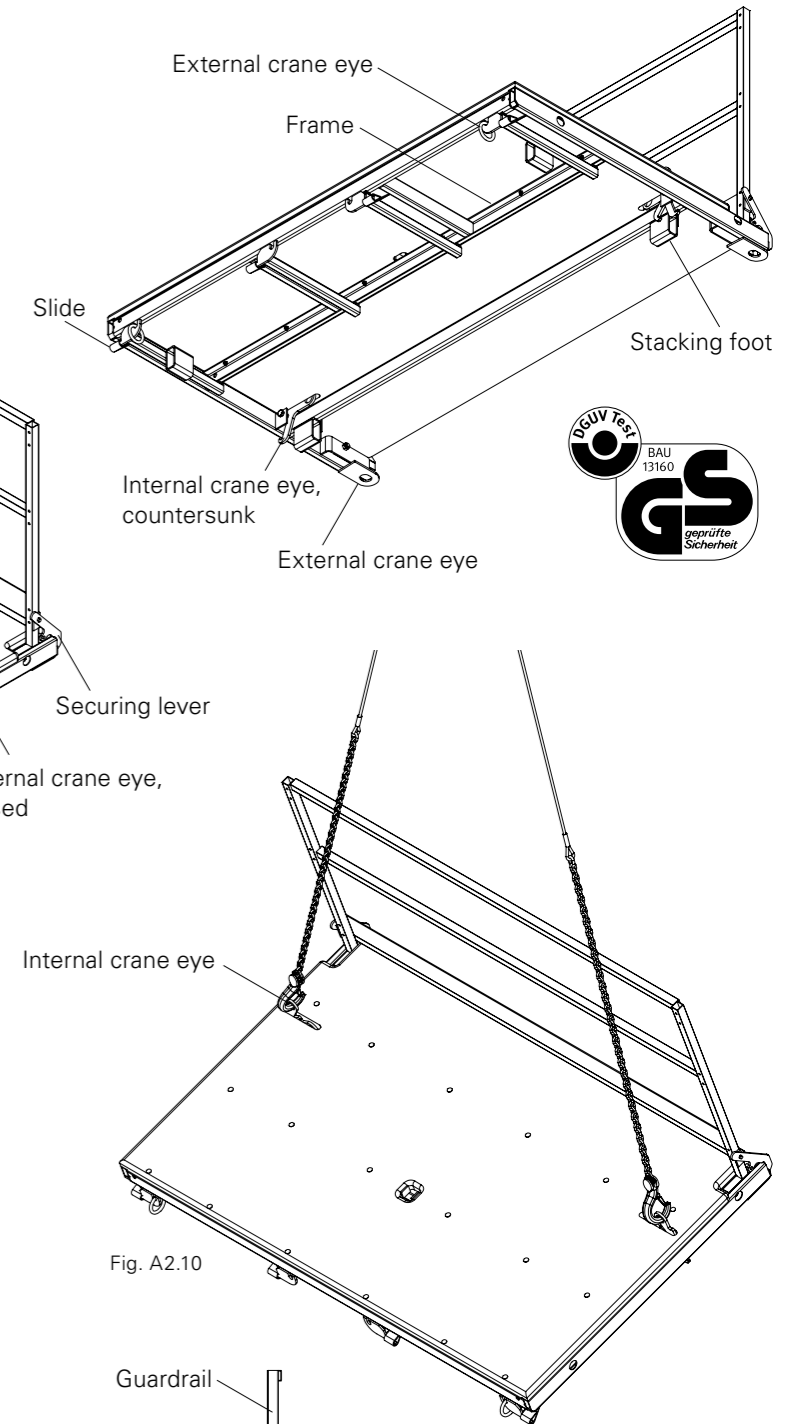

Fig. A2.10

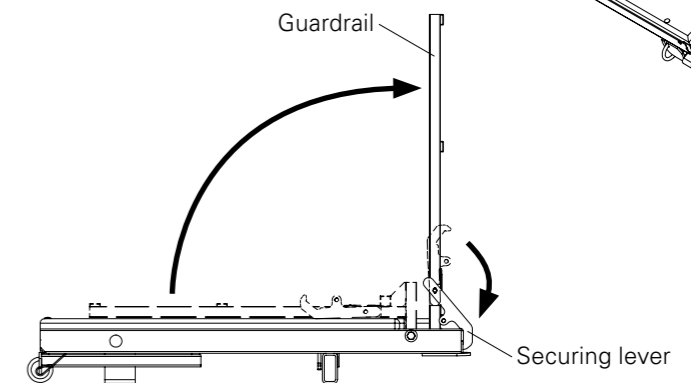

Fig. A2.09

## Notes regarding static calculations

This design information is used for the design and planning of the SKYDECK Slab Formwork System. It covers standard configurations for slab thicknesses from 0.14 m to 1.09 m.

### Comparison of the design methods

#### The design concept with partial safety factors

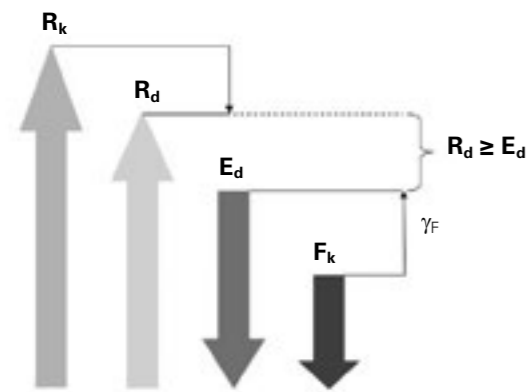

Method of proof

$$\frac{R_k}{\gamma_M} \geq F_k \cdot \gamma_F$$

$$R_d \geq E_d$$

#### Key

- $R_k$  = characteristic resistance
- $R_d$  = design value of the resistance
- $F_k$  =  $F_{actual.}$  = actual or characteristic action
- $E_d$  = design value of the action
- $F_{ult.}$  =  $R_k$  = characteristic resistance (e.g. breaking load)
- $F_{perm.}$  = Permissible load-bearing capacity

#### Design method used in this design information

This design information is based on the design concept with the absolute safety factor.

The tables of the prop loads include the permissible load-bearing capacities  $F_{perm.}$ . After multiplication using  $\gamma_F = 1.5$ , the maximum load-bearing capacity can also be converted into a design value of the resistance  $R_d$  for the method with partial safety factors.

#### The old design concept with the absolute safety factor (see PERI Design Tables)

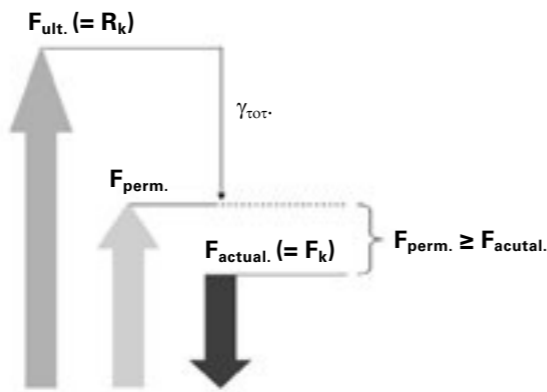

Method of proof

$$\frac{F_{ult.}}{\gamma_{tot.}} \geq F_{actual.} (= F_k)$$

$$F_{perm.} \geq F_{actual.} (= F_k)$$

- $\gamma_M$  = partial safety factor for the material (steel  $\approx 1.1$  / concrete  $\approx 1.5$ )
- $\gamma_F$  = partial safety factor for the load (permanent = 1.35 / changeable = 1.5)
- $\gamma_{tot.}$  = absolute safety factor  $\approx \gamma_M \cdot \gamma_F$  (steel  $\approx 1.65$  / concrete  $\approx 2.25$ )

## Internal forces and rigidity

### Permissible internal forces and rigidity for the design with single-span girders

Item no.	Designation	perm. M [kNm]	perm. Q [kN]	EI [kNm <sup>2</sup> ]
061100	Main Beam SLT 225	16.0	22.0	1198
061160	Main Beam SLT 375	12.6	22.0	1198
061110	Main Beam SLT 150	11.3	18.0	656
061045	Edge Beam SRT-2 150	2.9	8.0	91
061045	Edge Beam SRT-2 turned	2.1	8.0	31
061047	Edge Beam SRT-2 / 27	3.0	8.0	88
061047	Edge Beam SRT-2 / 27 turned	2.1	8.0	28
061049	Filler Timber SPH 150	0.7	2.4	32
061049	Filler Timber SPH turned	0.4	1.7	7
061050	Filler Timber SPH / 27	0.6	2.4	29
061050	Filler Timber SPH / 27 turned	0.3	1.3	7

Table A3.01

## Load combinations

### Vertical loads

#### Concreting

(according to DIN EN 12812)

SKYDECK dead load	$q_1$	=	0.20 kN/m <sup>2</sup>
Concrete load	$Q_{2,b}$	=	24.5 kN/m <sup>2</sup> x d [m]
Equivalent load concreting	$Q_4$	=	0.10 x $Q_{2,b}$ 0.75 kN/m <sup>2</sup> ≤ $Q_4$ ≤ 1.75 kN/m <sup>2</sup>
Equivalent load working conditions	$Q_{2,p}$	=	0.75 kN/m <sup>2</sup>
Total load	$Q$	=	$Q_1 + Q_{2,b} + Q_{2,p} + Q_4$

#### SKYDECK Platforms SDB

(according to DIN EN 12811)

Load Class 2	$q_1$	=	1.50 kN/m <sup>2</sup>
	$F_1$	=	1.50 kN (500 x 500 mm <sup>2</sup> )

#### Horizontal loads

Horizontal load from working operations	=	1% of the vertical load (EN 12812; 8.2.2.2)
Horizontal load from the tilting position	=	1% of the vertical load (EN 12812; 9.3.4.2)

#### Wind loads

Working wind dynamic pressure	$q_{W,A}$	=	0.20 kN/m <sup>2</sup> (EN 12811-1; 6.2.7.4.2)
Maximum wind speed dynamic pressure	$q_{W,max}$	=	0.60 kN/m <sup>2</sup>

Height of the substitute area for equipment and materials on the scaffold level

LF working wind	$h_{W,A}$	=	0.40 m (EN 12811-1, 6.2.7.4.2)
-----------------	-----------	---	--------------------------------

Height of the substitute area for equipment and materials on the scaffold level

LF maximum wind speed	$h_{W,max}$	=	0.20 m (EN 12811-1, 6.2.7.4.1)
-----------------------	-------------	---	--------------------------------

Wind on the side protection:

Working wind speed on SKYDECK Guardrail Holder SGH and Guardrail Post SGP

$q_{W,A,S}$	=	0.183 kN/m
-------------	---	------------

Maximum wind speed with SKYDECK Guardrail Holder SGH and Guardrail Post SGP

$q_{W,max,S}$	=	0.550 kN/m
---------------	---	------------

# A3 System dimensions



Overview of the required frames:  
**MRK with the use of MULTIPROP Towers**  
**PRK with the use of PEP Props**

Frame	MRK Item no.	PRK Item no.	SKYDECK system
62.5 Steel	028390	111811	– Inset beam at beginning of wall with 75 cm panel span. – Inset prop at beginning of wall with Combihead.
75 Steel	028400	111812	– Panel span 75 cm.
137.5 Steel	028380	111813	– Inset beam at beginning of wall with 150 cm panel span.
150 Steel	028350	111814	– Panel span 150 cm.
201.5 Alu	028460	111815	– Inset prop at beginning of wall under SLT 225 with Prophead or Combihead.
225 Alu	028360	111816	– SLT 225 on Prophead or Combihead. – Use of Cantilever Beam SLT 375 on Prophead/Combihead or corner tables.
230 Alu	028470	111817	– SLT 225 on Dropheads.

Table A3.02

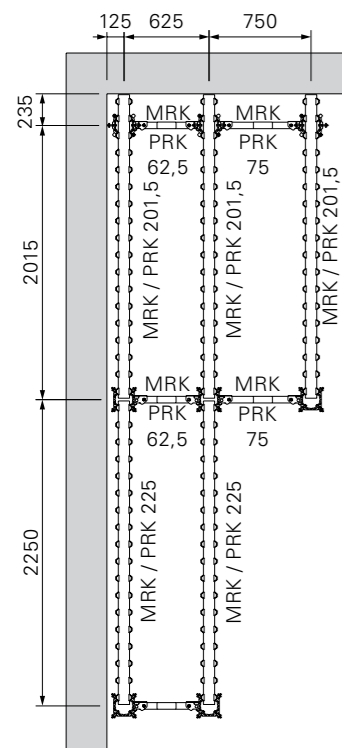

Fig. A3.01

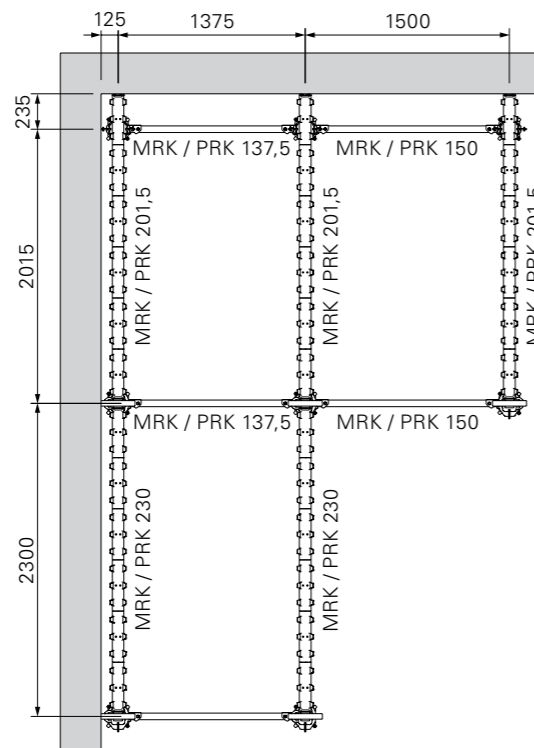

Fig. A3.02

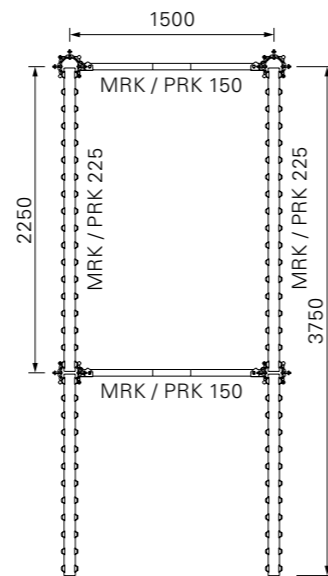

Fig. A3.03

# A4 Shuttering



## Starting bay



**Shuttering is carried out using a safe mobile platform!**

### Position props and main beams

1. Position prop with Prophead (6) in one corner of the room (spacing: see Fig. A4.05).
2. Secure with tripod to prevent it from falling over.
3. Position prop with Drophead (1). Distance from the wall 2.275 m. (Fig. A4.01)
4. Secure with tripod to prevent it from falling over.
5. Insert Main Beam SLT 225 (2) into the beam support of the Prophead and Drophead. The main beam connection (2.1) must be mounted in the middle of the beam support (1.2) of the SKYDECK heads. (Fig. A4.02a / A4.02b / A4.02c)
6. Secure Main Beam SLT 225 (2) with Wall Holder SWH-2 (8).
7. Position second pair of props at a distance of 1.50 m from the wall.
8. Insert Main Beam SLT 225 (2) in the beam support. (Fig. A4.02a / A4.02b / A4.02c / A4.04)



Does the main beam connection (2.1) enclose the beam support (1.2)? (Fig. A4.02c)



Set up drophead props on the wall so that the drophead wedge can be removed during striking. The Main Beam SLT is always positioned parallel to the long wall side. Always check the rectangularity of the first bay.

### Components:

- 1 Drophead SFK
- 2 Main Beam SLT
- 6 Prophead SSK
- 8 Wall Holder SWH-2

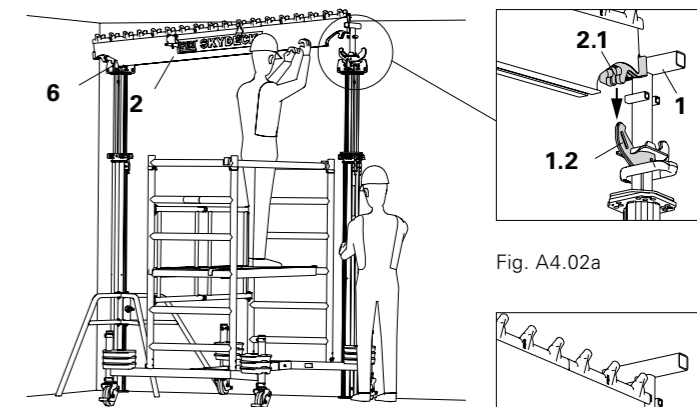

Fig. A4.01

Fig. A4.02a

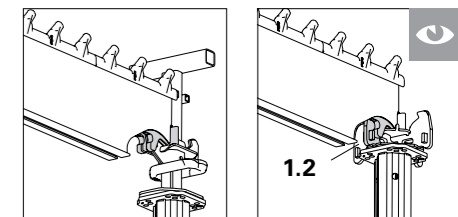

Fig. A4.02b

Fig. A4.02c

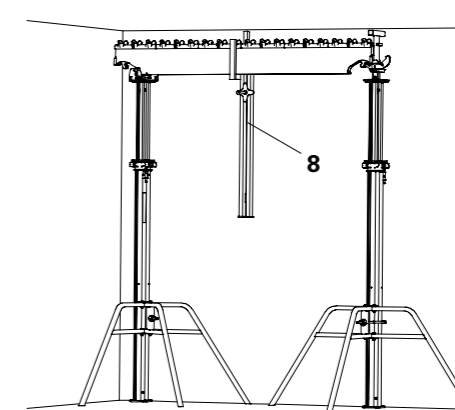

Fig. A4.03

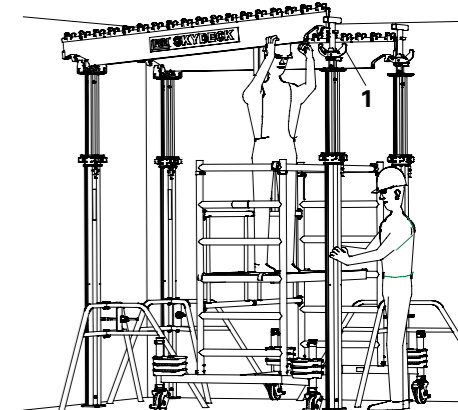

Fig. A4.04

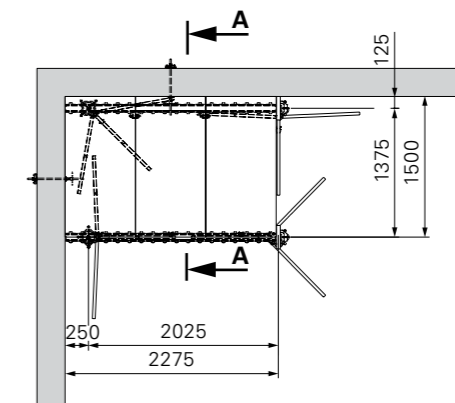

Fig. A4.05

### Section A-A

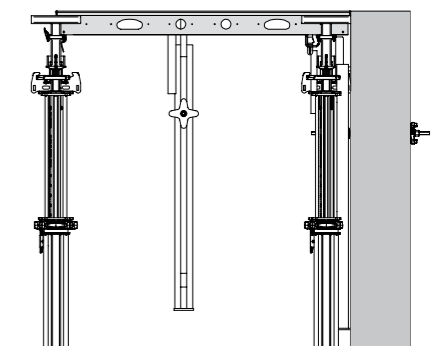

Fig. A4.05a

## Insert panels

1. Install panels (3) on the Main Beam SLT 225 (2).  
→ The rack of the Main Beam SLT fixes the panel in position.
2. Secure wall-side panel and Main Beam SLT with Wall Holder SWH-2 (8). (Fig. A4.06)
3. Install two additional panels. (Fig. A4.07)  
→ The starting bay is complete. (Fig. A4.08)



Spray the edge of the panel with release agent before shuttering.

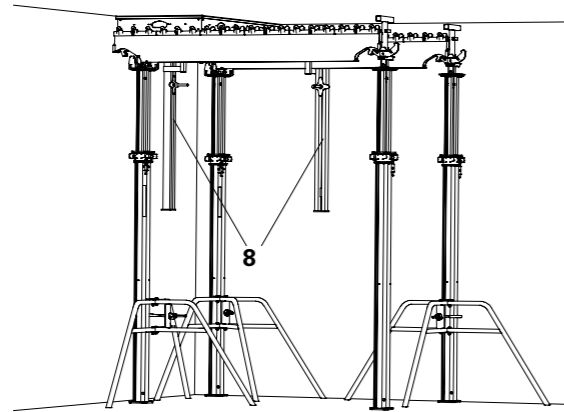

Fig. A4.06

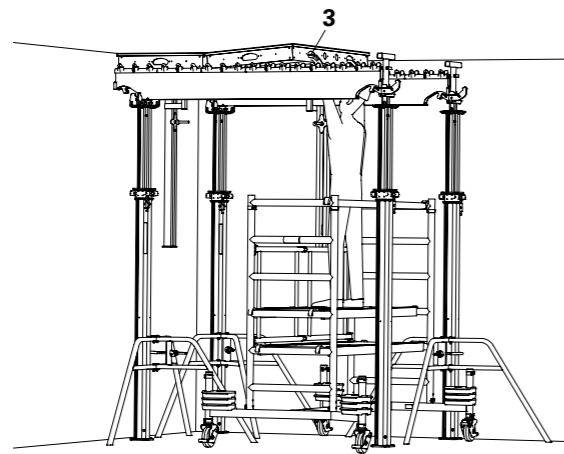

Fig. A4.07

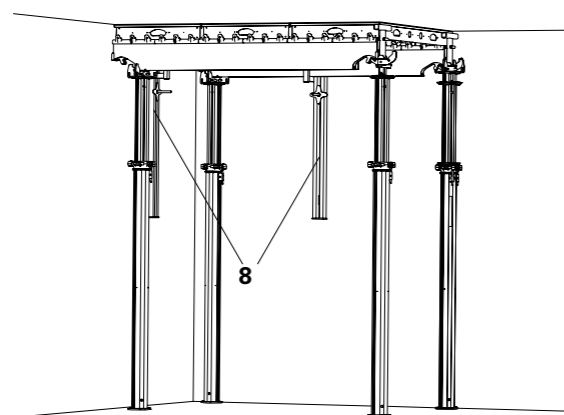

Fig. A4.08

## Wall Holder SWH-2



**The formwork surface area may only be accessed or loaded when Wall Holders SWH-2 have been installed!**

The Wall Holder SWH-2 (8) is used to hold the slab formwork in a horizontal position during the assembly. It is installed in longitudinal and transverse directions, and can fix the main beam as well as the panel. The Wall Holder SWH-2 (8) is mounted in every second bay.

## Assembly

1. Insert tie rod with wingnut pivot plate through the available tie hole.
2. Place Main Beam SLT into the Wall Holder SWH-2 or push into the edge of the panel.
3. Tighten Wall Holder SWH-2 with wingnut Pivot plate on the wall.
4. Remove tripods. (Fig. A4.08)  
→ The wall holder is assembled.

## Transverse bay

1. Position prop with Prophead SSK (6). Spacing 1.50 m.
2. Secure with tripod.
3. Position prop with Drophead SFK (1). Spacing 2.275 m.
4. Insert Main Beam SLT 225 (2) into the beam support of the Prophead and Drophead. (Fig. A4.09)
5. Secure with tripod.
6. Insert panels (3). (Fig. A4.10)  
→ The transverse bay is complete. (Fig. A4.11)



**Shuttering is carried out using a safe mobile scaffold!**



Working in a transverse direction is recommended.  
Use tripods again in the next bay.

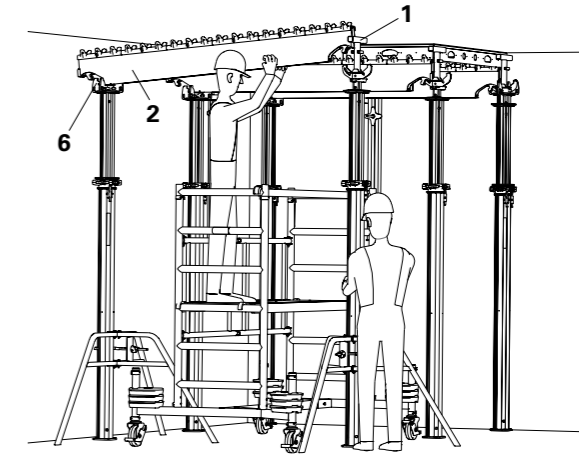

Fig. A4.09

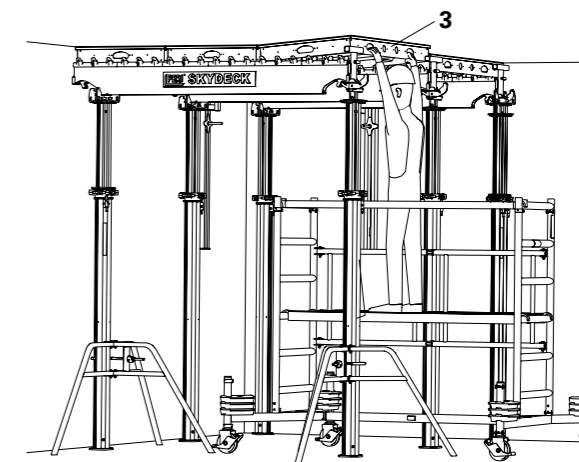

Fig. A4.10

## Components:

- |   |                   |
|---|-------------------|
| 1 | Drophead SFK      |
| 2 | Main Beam SLT     |
| 3 | Panel SDP         |
| 6 | Prophead SSK      |
| 8 | Wall Holder SWH-2 |

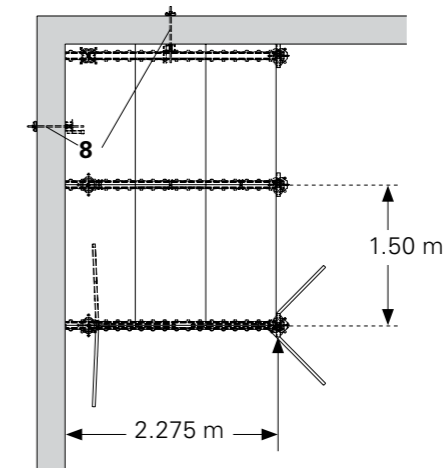

Fig. A4.11

## Longitudinal bay



Based on the risk assessment, the contractor must decide whether forming takes place from above or below!

1. Attach Main Beam SLT 225 (2) to the Drophead.
  2. Connect prop with Drophead in the main beam. (Fig. A4.12)
  3. Place prop in a vertical position. (Fig. A4.12a)
  4. Secure with tripod.
  5. Proceed likewise with the second main beam and prop.
  6. Insert panels (3). (Fig. A4.13)
  7. Remove tripod and use again in the next bay.
- The longitudinal bay is now complete. (Fig. A4.14)

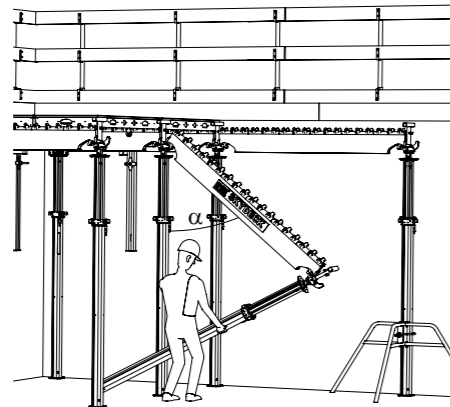

Fig. A4.12

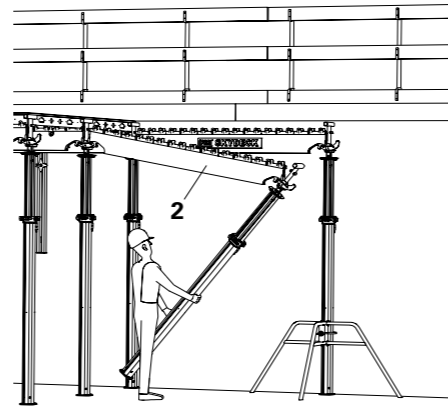
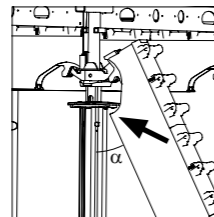

Fig. A4.12a



Optimum angle for mounting the Main Beam SLT up to  $\alpha 45^\circ$ . The main beam is correctly fitted if the corner of the recess hangs under the prop without obstruction.



The Wall Holder SWH-2 (8) is mounted in every second bay.



### Risk of falling!

- When working on the slab formwork, measures must be taken to prevent falling, e.g. PPE.
- When shuttering from below, use a safe and secure mobile scaffold; install panels overhead.



The SKYDECK Guardrail Holder must be installed during the shuttering process of the panels. For details, see Section A8.

### Components:

- 2 Main Beam SLT
- 3 Panel SDP
- 4 Cover Strip SAL
- 5 Pallet SD
- 8 Wall Holder SWH-2

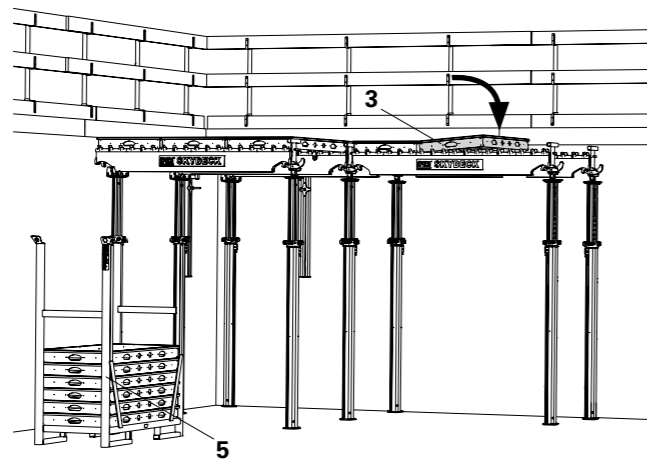
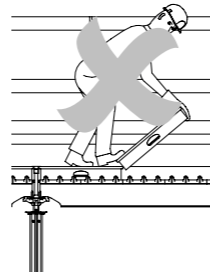

Fig. A4.13



Do not Install Panels from on top of the deck being assembled.

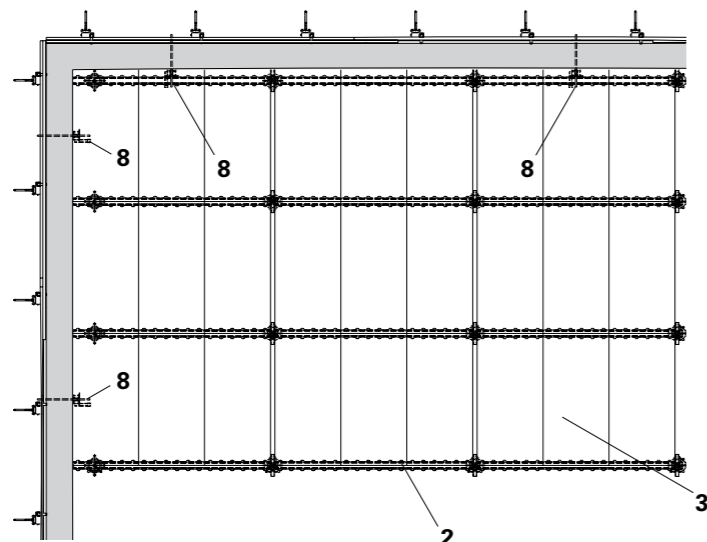

Fig. A4.14

## Standard bay

Due to the recurring assembly sequence, the procedure is always the same.



With all-round enclosed structure geometries, panels are to be fixed by means of two Panel Clips SPK (21) each time to the main beams for wind speeds between  $0.033 \text{ kN/m}^2$  (26 km/h) and dynamic pressure  $0.061 \text{ kN/m}^2$  (36 km/h). For unfavourable structure geometries or larger wind speeds, additional securing measures are to be implemented, e.g.:

- ballast
- bracing
- dismantling the formwork etc.

1. Attach Main Beam SLT 225 (2) to the Drophead.
  2. Connect prop with Drophead SFK in the lifted main beam. (Fig. A4.15)
  3. Place prop in a vertical position.
  4. Insert panels (3).
- The standard bay is now complete.

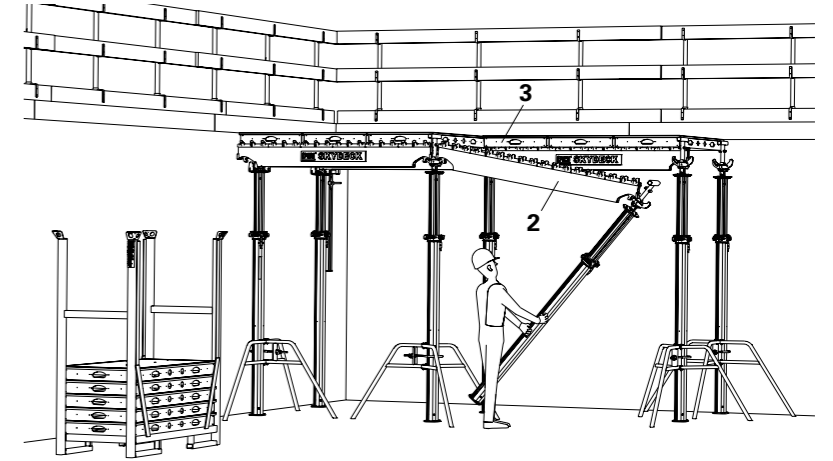

Fig. A4.15

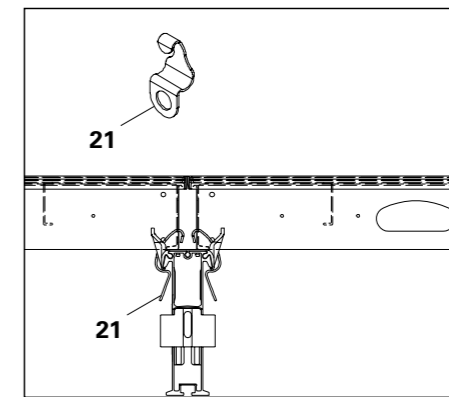

Fig. A4.16

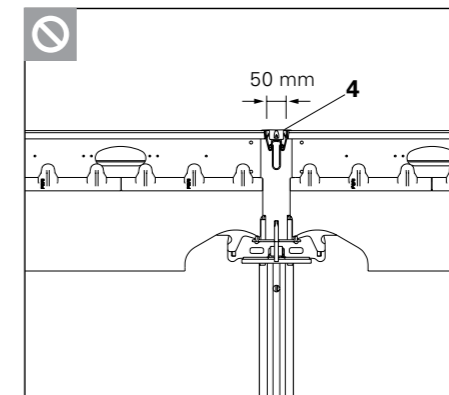

Fig. A4.17

The Prophead SSK is not a substitute for the Drophead. Without the Drophead, the Cover Strip (4) has no supporting effect.

## Shuttering the casting segment

Set down Pallet SD (5) with panels (3) onto the forming area. Place panels in the main beams. Make empty pallets available in preparation for the striking process. (Fig. A4.18)

1. Shutter the standard bays until there is no more space for the Main Beam SLT 225 or Compensation Beam SLT 150.
2. Form the infill areas. See A5.
3. Continually insert Cover Strip SAL (4). (Fig. A4.19)
4. Thinly spray the forming area with a release agent - also from below if used for the first time.

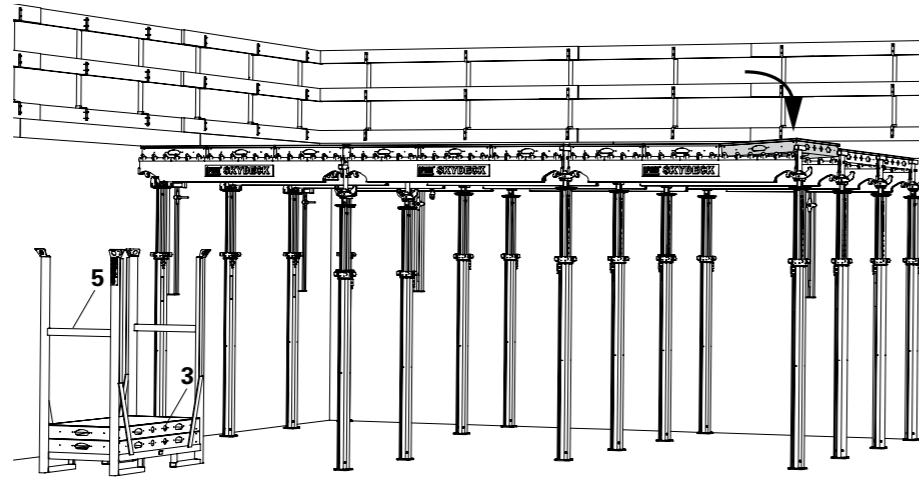

Fig. A4.18



### Risk of slipping!

The forming area becomes slippery through the use of release agents!

- Be extremely careful when accessing forming areas after spraying!
- Weather conditions are to be taken into account!



- Only begin with the reinforcement work when the Cover Strips have been installed!

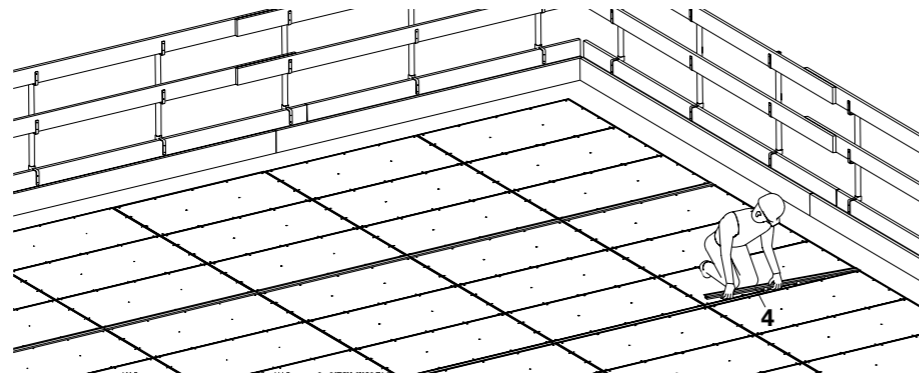

Fig. A4.19



For the tightness of the panel joints, e.g. for casting segments/setting of stopends, push the panels tightly together and secure on the last main beam with Panel Wedge Clips SPKK (20).

(Fig. A4.20 - Fig. A4.22)

### Application possibilities

1. Panel joint in the middle of main beam

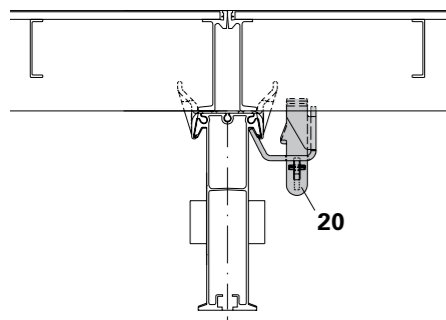

Fig. A4.20

### 2. Overlapping panel

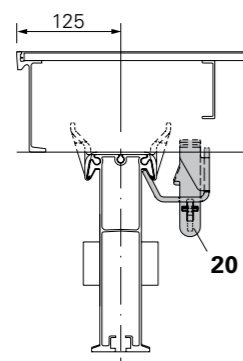

Fig. A4.21

### Side view

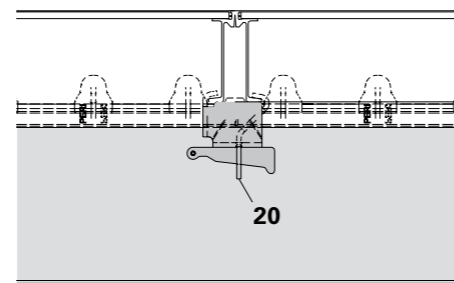

Fig. A4.22

### Panel Wedge Clip SPKK

The panel wedge clip is used to connect 2 panels with one main beam.

## Shuttering with Prophead



### Risk of injury!

If slab props with mounted Propheads fall over or are otherwise used improperly, this may result in damage to the Prophead.

As a result, Propheads could fail during further use and cause serious injuries to site personnel.

- Dismantle Propheads after incorrect use and check for any signs of damage, e.g. cracked weld seams!
- Damaged components must not be used!



In deviation from shuttering operations with Dropheads, the following applies to shuttering with Propheads in the longitudinal field:

- Prop spacing in main beam direction 2.25 m.
- When using the Frame MRK, select the 225 length.
- Use slab props with Propheads instead of Dropheads.
- Early striking is not possible with Propheads.
- The installation of Cover Strips is not required.

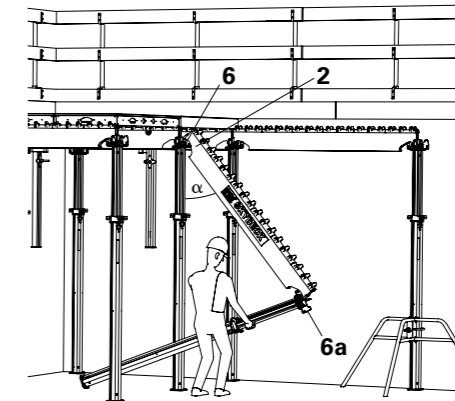

Fig. A4.23

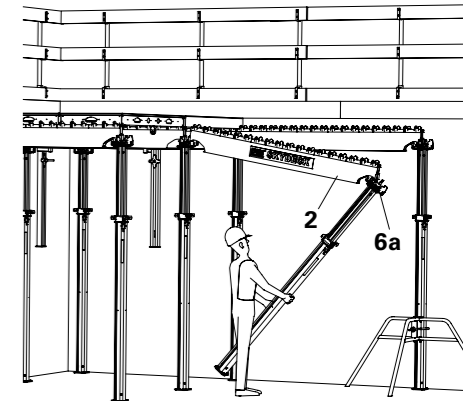

Fig. A4.23a

### Assembly

Assembly correspondingly takes place as described in Section A4 Longitudinal bay.



Abb. A4.24

### Components:

- |          |                   |
|----------|-------------------|
| <b>2</b> | Main Beam SLT     |
| <b>3</b> | Panel SDP         |
| <b>6</b> | Prophead SSK      |
| <b>8</b> | Wall Holder SWH-2 |

## System components

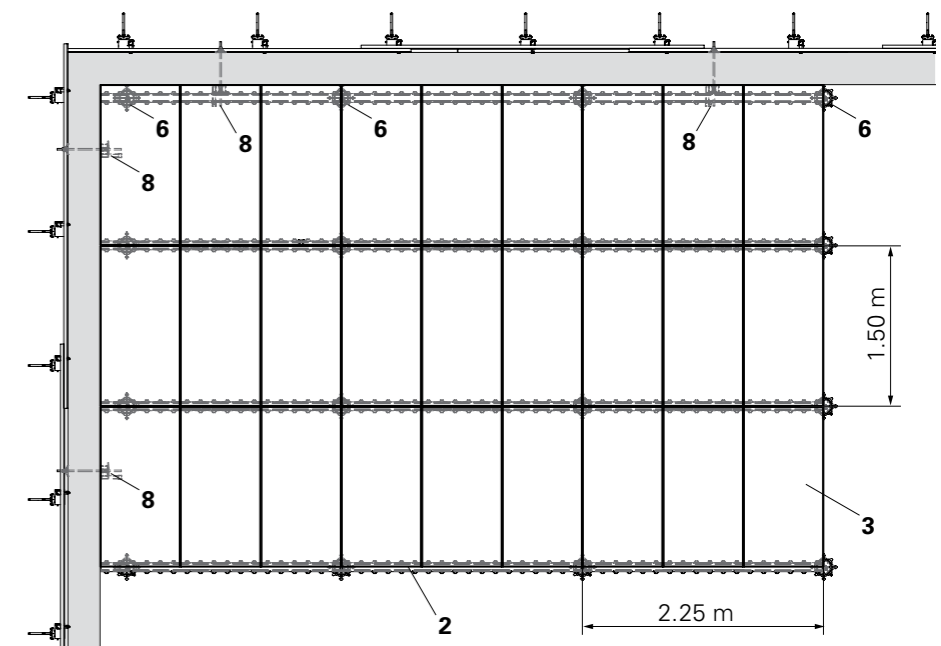
For the realization of compensations and shuttering of columns, a range of system components is available.



**Secure filler plates with nails!**

## Edge Beam SRT 150-2, SRT 75-2

Install vertically (Fig. A5.01) or suspended (Fig. A5.02).

The locking pin (9.1/10.1) secures the Edge Beam SRT 150-2 (9) or SRT 75-2 (10):

- to the Main Beam SLT in a longitudinal direction. (Fig. A5.01 + A5.02)
- to the Prophead SSK in a transverse direction. (Fig. A5.03)
- to the Combihead SCK (7) in a longitudinal direction. (Fig. A5.04)
- in the End Support SSL (11) in a longitudinal direction. (Fig. A5.07)

## Filler Timber SPH

Install Filler Timber SPH (12) vertically or horizontally.

- to the Combihead SCK. (Fig. A5.04)
- nailed laterally on the panel.
- horizontally, transverse to the suspended Edge Beam SRT. (Fig. A5.05 + A5.06)

## End Support SSL

Use the End Support SSL as height adjustment for the transition from a standard bay to an infill area. (Fig. A5.07)

The End Support SSL must always be directly supported by means of a Prophead, Drophead or Combihead. (Fig. A5.08)

## Components:

- 2 Main Beam SLT
- 3 Panel SDP
- 7 Combihead SCK
- 9 Edge Beam SRT 150-2
- 9\* Edge Beam SRT 150-2, suspended
- 10 Edge Beam SRT 75-2
- 10\* Edge Beam SRT 75-2, suspended
- 11 End Support SSL
- 12 Filler Timber SPH

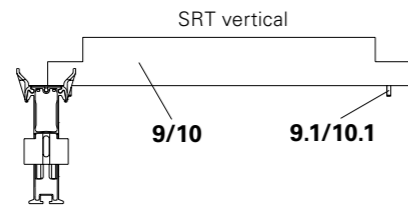

Fig. A5.01

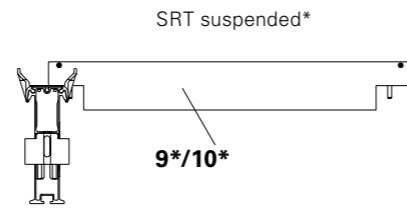

Fig. A5.02

The asterisk (\*) refers to the installation in a suspended position.

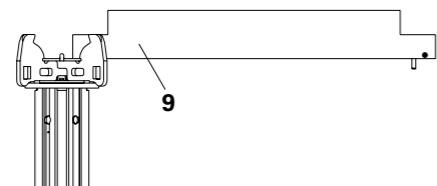

Fig. A5.03

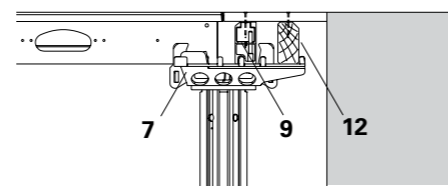

Fig. A5.04

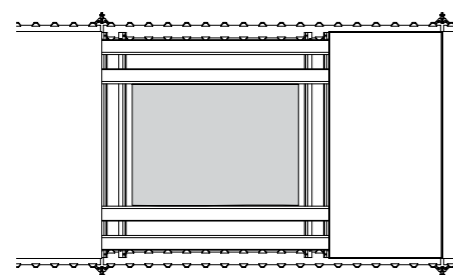

Fig. A5.05

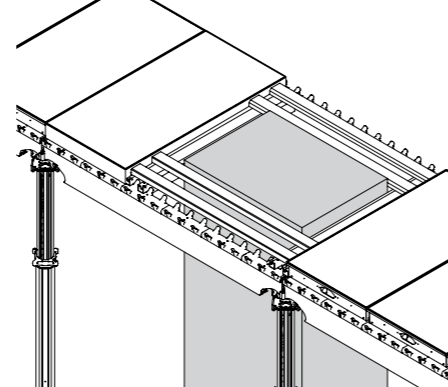

Fig. A5.06

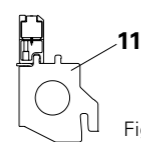

Fig. A5.07

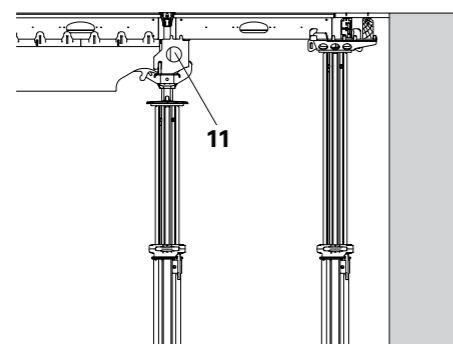

Fig. A5.08

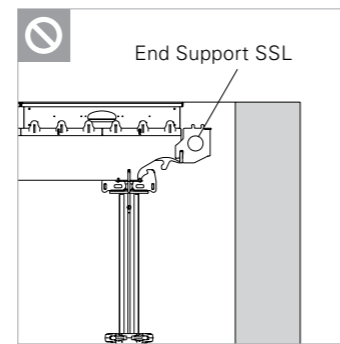

Fig. A5.09



No End Support SSL without any direct support through Prophead, Drophead or Combihead.

## Combihead SCK

Used for longitudinal and transverse infills up to 25 cm.

The cantilever of the Head Plate is  $\leq 19$  cm in longitudinal direction and  $\leq 12.5$  cm in transverse direction.

The Combihead (7) (Fig. A5.11) is a secure, non-movable and non-twisting support for:

- Main Beam SLT 225 (2).
- SLT 150 (2.5). (Fig. A5.10)
- Panel SDP (3). (Fig. A5.12)
- Edge Beam SRT-2 (9) and Filler Timber SPH (12) or timber provided by the contractor with  $b = 3.8 - 8$  cm and  $h = 9.8$  cm. (Fig. A5.13)
- End Support SSL (11). (Fig. A5.14)

## Mounting the main beam

The Main Beam SLT must be mounted in the middle of the beam support of the SKYDECK Heads. The main beam connection (2.1) encloses the main beam support (7.1) of the head. (Fig. A5.10)

The Combihead SCK has 2 main beam supports and can be installed in both directions. In infill areas, the cantilever points towards the compensation.

## Exceptions:

The cantilever points towards the main beam

- when using the End Support, (Fig. A5.14)
- when infill  $\leq$  cantilever. (Fig. A5.14a)

## Positioning the main beam

With inset props, the cantilever of the Combihead always points towards the main beam.

Position the Combihead so that the main beam support is securely positioned in the groove (2.8) of the main beam. (Fig. A5.15)

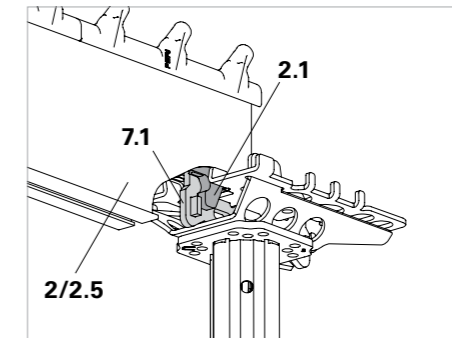

Fig. A5.10

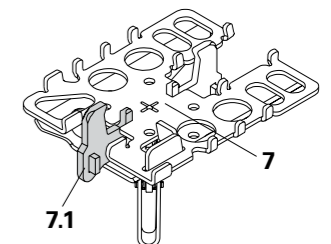

Fig. A5.11

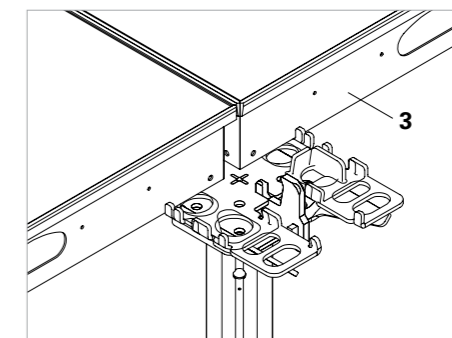

Fig. A5.12

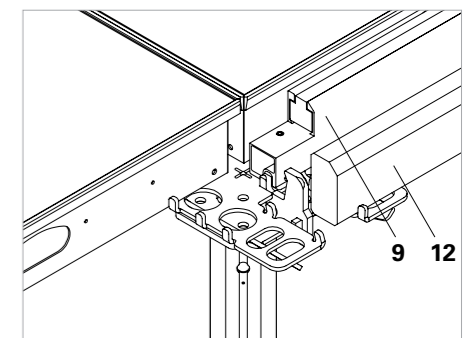

Fig. A5.13

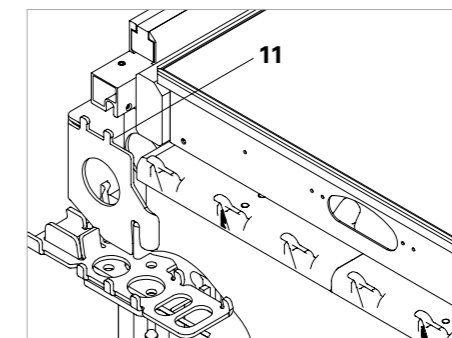

Fig. A5.14

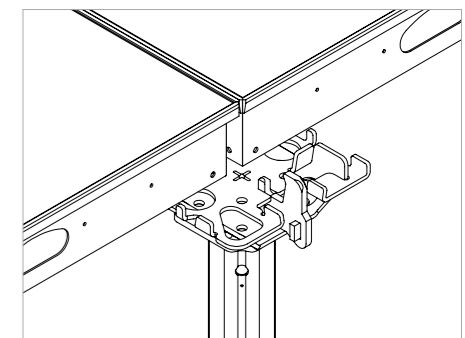

Fig. A5.14a

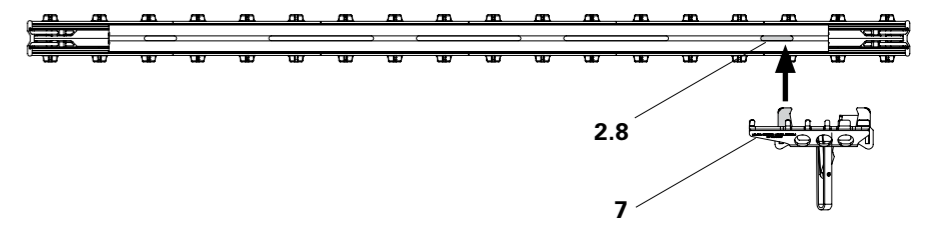

Fig. A5.15

# A5 Compensations



## Inserting panels

With direct panel support, install the cantilever of the Combihead in the direction of the infill area. (Fig. A5.16)

The teeth in the plastic racks (7.2) on the cantilever hold the panels (3) in 5 different positions. Select support position according to the compensation width. Position the cantilever of the Combihead SCK as close as possible to the wall in order to provide maximum support for the infill area. (Fig. A5.17c - A5.17d)

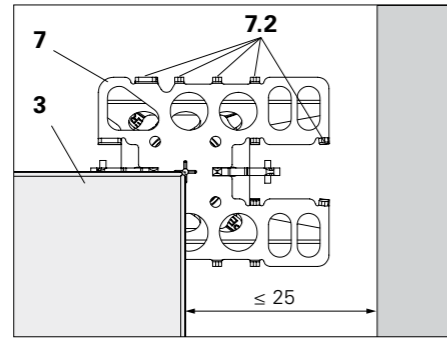

Fig. A5.16

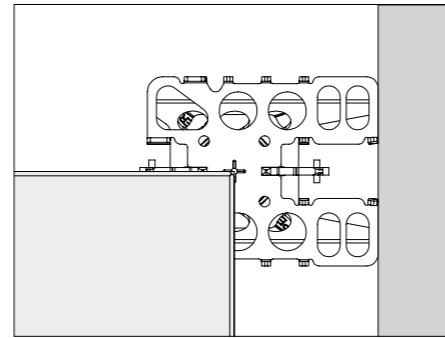

Fig. A5.17

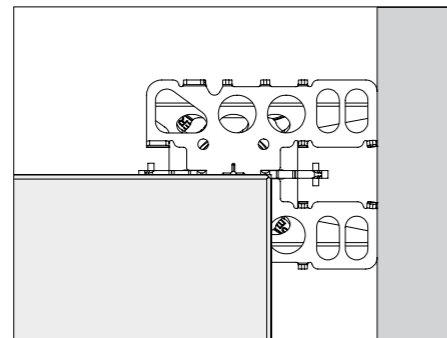

Fig. A5.17a

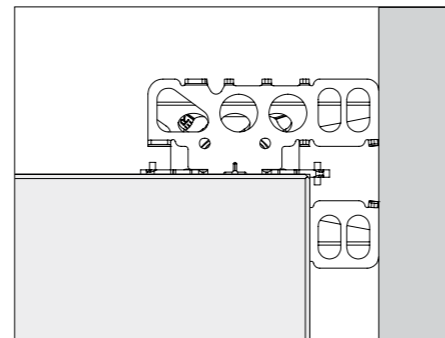

Fig. A5.17b

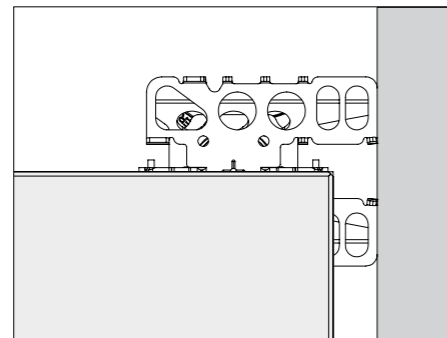

Fig. A5.17c

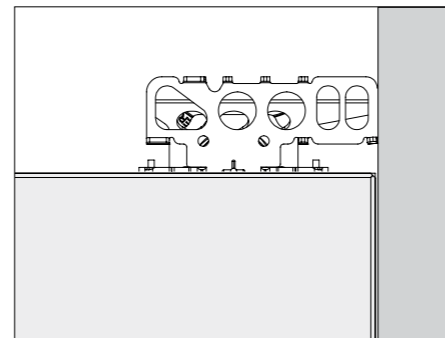

Fig. A5.17d

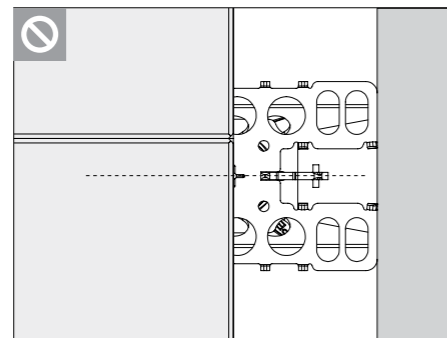

Fig. A5.17e

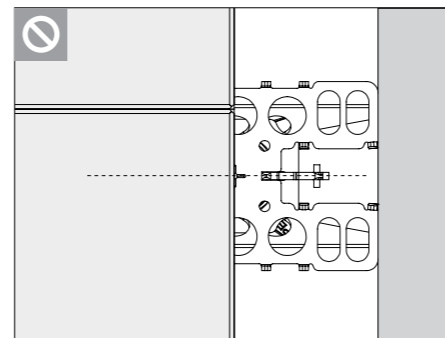

Fig. A5.17f



Do not install panels in a longitudinal direction outside of the longitudinal axis of the Combihead. (Fig. A5.17e + A5.17f)

## Components:

- 1 Drophead SFK
- 2 Main Beam SLT
- 3 Panel SDP
- 7 Combihead SCK
- 14 Triangular Frame SDR

# A5 Compensations

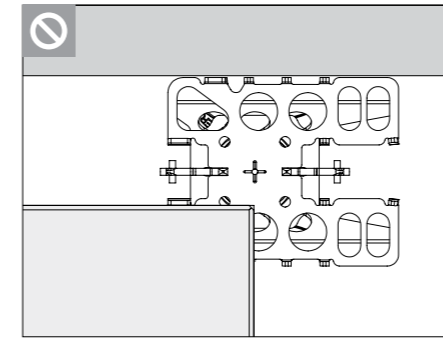

Fig. A5.18

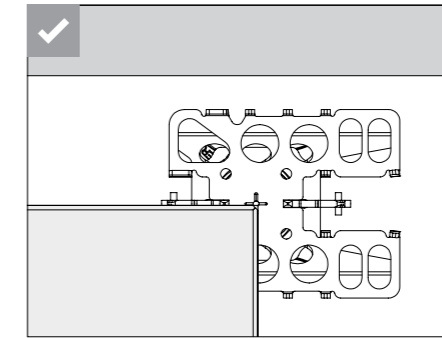

Fig. A5.18a

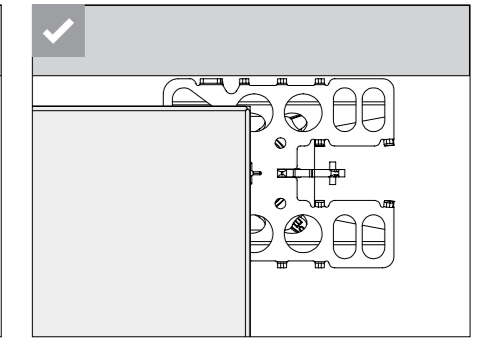

Fig. A5.18b



With a transverse positioned Combihead, e.g. in compensation areas, position panels at least as far as the central axis or further!

In corners where longitudinal and transverse compensations meet, the Combihead (7) is aligned in the direction of the main beam. (Fig. A5.19 A)

Install the cantilever of the Combihead (7) up to the compensation area. (Fig. A5.19 B)

In the system with the Drophead (1), the Combihead (7) is always installed transversely if it is positioned under a cover strip. As a result, the panels are prevented from slipping out of position. (Fig. A5.19 C)

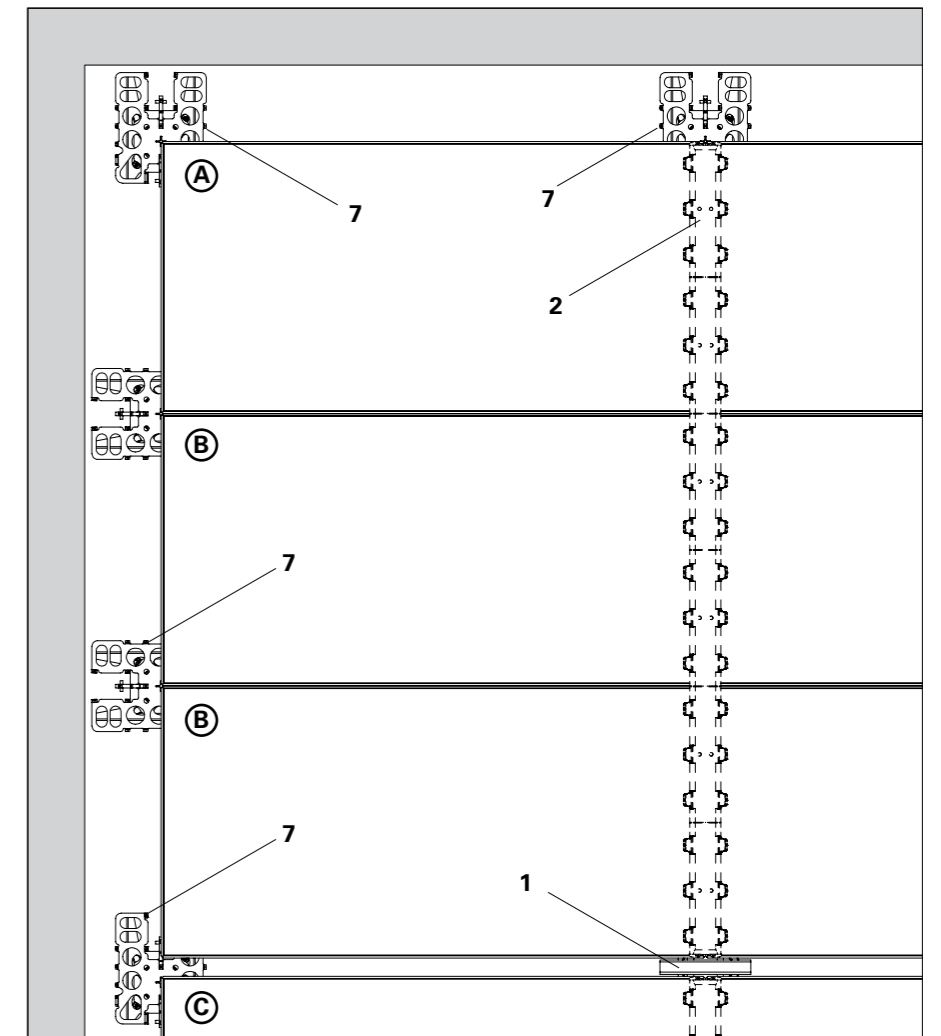

Fig. A5.19

# A5 Compensations



## Triangular Frame SDR 150/75, 75/75

Form infill areas with inclined walls using triangular frames.

### Forming the infills

1. Continue forming in the system as long as possible.
2. Carry on forming operations with filler panels as well as transversely inserted panels - as for longitudinal and transverse compensations.
3. Lay Triangular Frame (14) on the support (Main Beam, Prophead or Combihead, End Support). (Fig. A5.20)
4. Place the support on the wall side.
5. Install formlining and secure in position with nails.

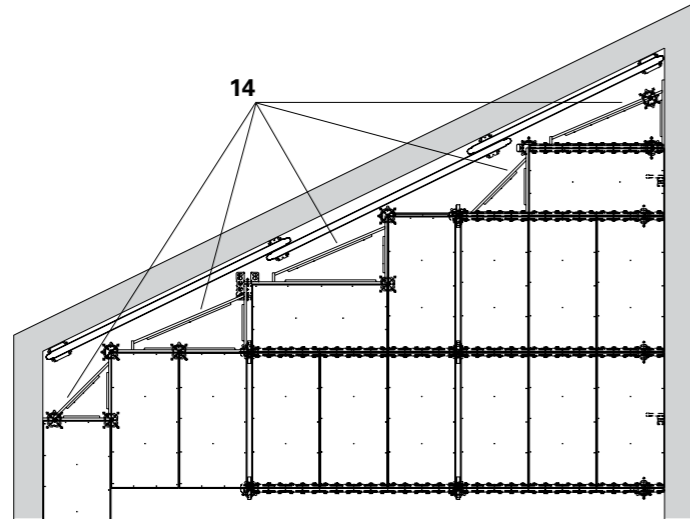

Fig. A5.20

## Length compensations



### Secure filler plates with nails!

#### Drophead infills up to 2.25 m + 5 cm. Prophead infills up to 2.25 m.

Length of room minus  $n \times 2.30$  m (2.25 m) = compensation area. See Tables: Filler plates, forming around columns

#### Forming longitudinal compensations between 75 cm and 2.25 m

1. Continue forming with prop, Compensation Beam SLT 150 (2.5) and Panel SDP (3) as in the standard bay. (Fig. A5.21)
2. Depending on the required load-bearing capacity, continue forming with filler panels. See PERI Tables.
3. Forming of gaps up to 75 cm, see following pages.

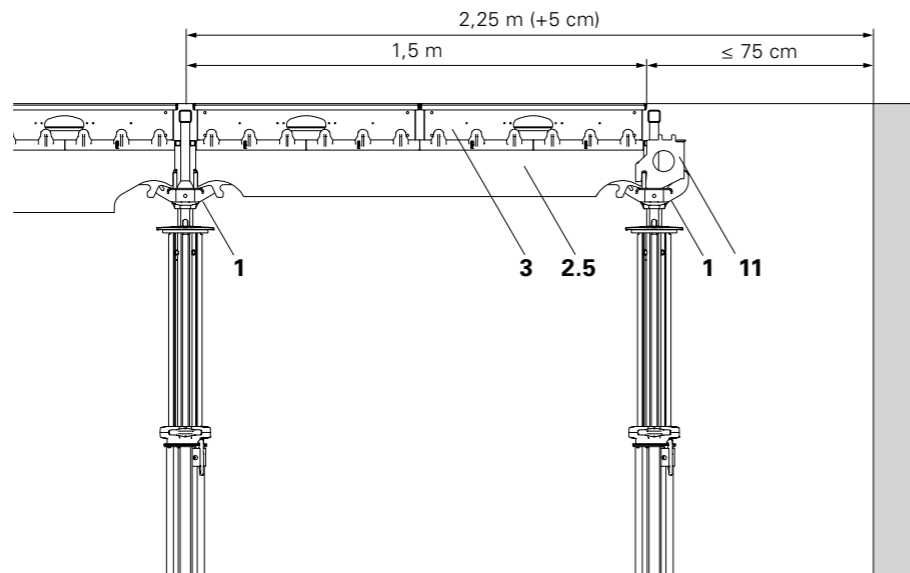

Fig. A5.21



- Take into account the load-bearing capacity and supporting direction of the formlining. See PERI Tables.
- Timbers are securely nailed on the panel inner side before panels are assembled. Use the nail holes in the panel edge struts.

# A5 Compensations



## Gap 0 - 6 cm

1. Place Combihead SCK (7) or Prophead SSK (6) in a recessed position under the Main Beam SLT (2.5).
2. Nail Filler Timber SPH (12) or timber up to max. 6 cm on the panel.
3. Install formlining (16) and secure with nails. (Fig. A5.22 + A5.23)

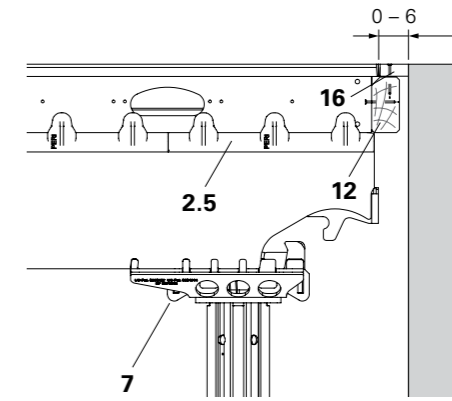

Fig. A5.22

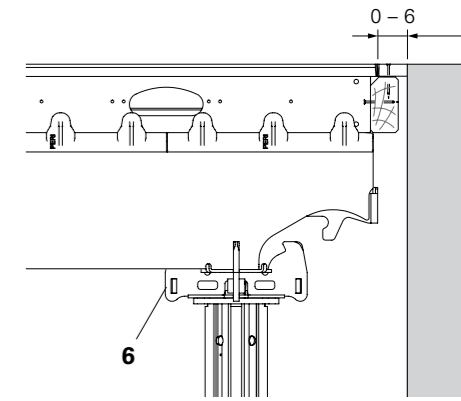

Fig. A5.23

## Gap 5 - 12.5 cm

1. Place Main Beam SLT (2) on inset prop with Combihead SCK (7) or Prophead SSK (6).
2. Place additional props with transversely positioned Combihead SCK (7a) in an offset arrangement.
3. Install Filler Timber SPH (12) or Edge Beam SRT-2 (9).
4. Install formlining and secure in position with nails. (Fig. A5.24 + A5.25)

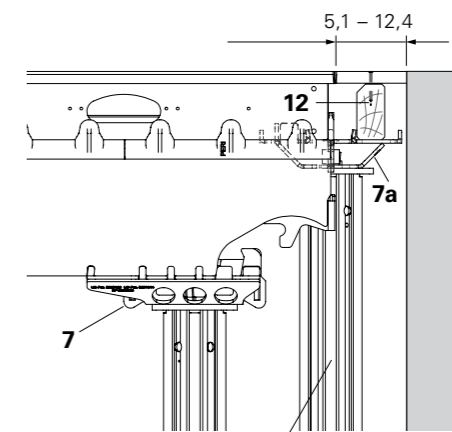

Fig. A5.24

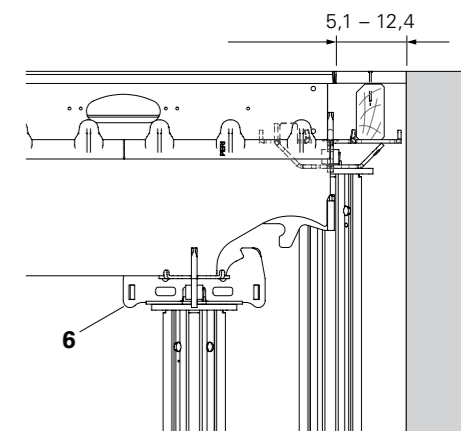

Fig. A5.25

Offset prop arrangement.

### Components:

- 1 Drophead SFK
- 2.5 Main Beam SLT 150
- 3 Panel SDP
- 6 Prophead SSK
- 7 Combihead SCK
- 9 Edge Beam SRT-2 150
- 11 End Support SSL
- 12 Filler Timber SPH
- 13 Timber
- 14 Triangular Frame
- 15 Additional prop with crosshead and formwork girder
- 16 21 mm formlining provided by the contractor

## Gap 12.5 - 20 cm

1. Mount Combihead SCK turned by 180° (7) or Prophead SSK in the main beam support.
2. Install End Support, Filler Timber and Edge Beam.
3. Install formlining and secure in position with nails. (Fig. A5.26 + A5.27)

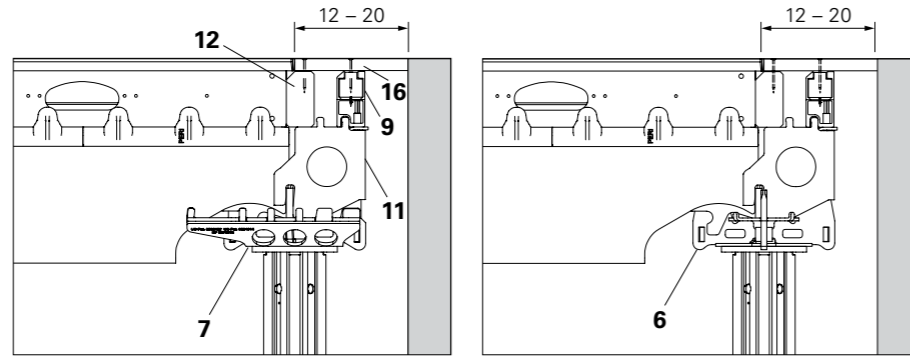

Fig. A5.26

Fig. A5.27

## Gap 20 - 75 cm

1. Install Main Beam in Drophead SFK (1) (Fig. A5.31), Combihead SCK (7) turned by 180° (Fig. A5.32) or Prophead SSK (6) (Fig. A5.33).
2. Mount End Support (11) and Edge Beam (9).
3. Position additional prop with cross-head and formwork girder (15).
4. Install formlining and secure in position with nails. (Fig. A5.28 - A5.30)

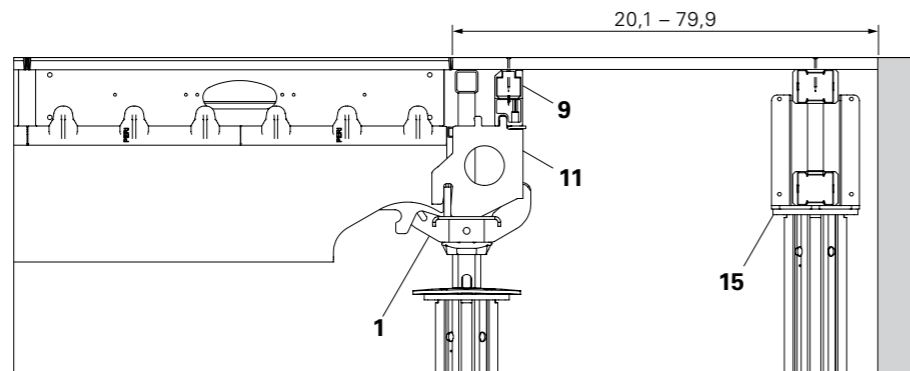

Fig. A5.28

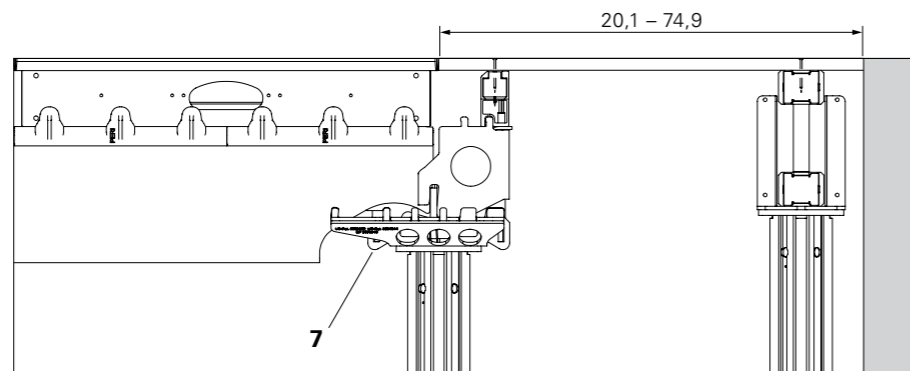

Fig. A5.29

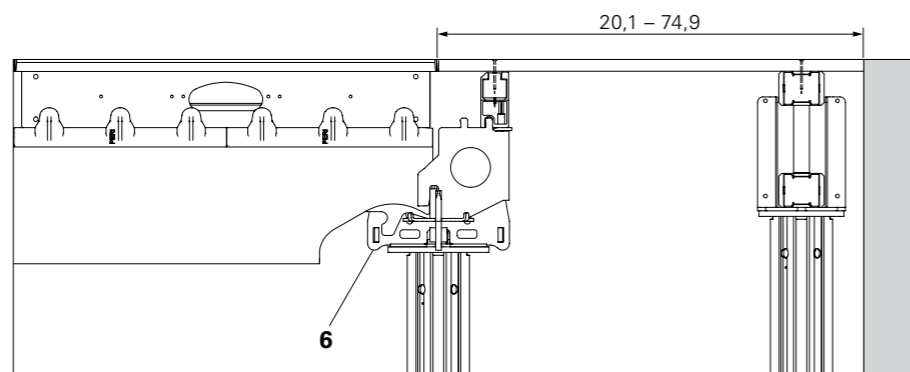

Fig. A5.30

## Transverse compensation



### Secure filler plates with nails!

Max. infills are 1.50 m.  
 Infills are calculated based on the room length -  $n \times 1.50$  m.  
 See Tables: Filler plates, forming around columns

### Forming the infills

#### Transverse infill between 75 cm and 1.50 m

1. Continue forming with prop, Main Beam SLT 225 (2) and transversely-positioned panel (3). Close the spacing to the next prophead with Panel SDP 75 x 75 (3a). (Fig. A5.31 + A5.32)
2. Depending on the required load-bearing capacity, continue forming with filler panels. See PERI Tables.
3. Form gaps up to 75 cm; see following pages.



- Take into account the load-bearing capacity and supporting direction of the formlining. See PERI Tables.
- Timbers are securely nailed or screwed on the panel inner side before panels are assembled. Use the nail holes in the panel edge struts.

### Components:

- 1 Drophead SFK
- 3 Panel SDP
- 6 Prophead SSK
- 7 Combihead SCK
- 9 Edge Beam SRT-2 150
- 11 End Support SSL
- 12 Filler Timber SPH
- 15 Additional prop with crosshead and formwork girder
- 16 21 mm formlining provided by the contractor

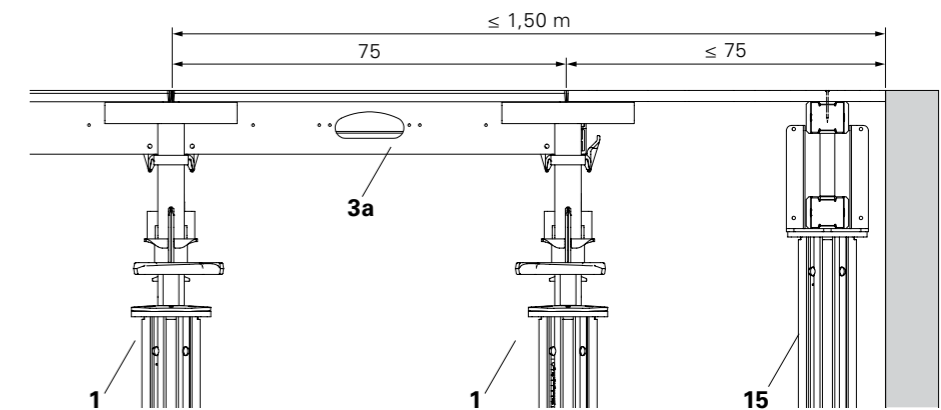

Fig. A5.31

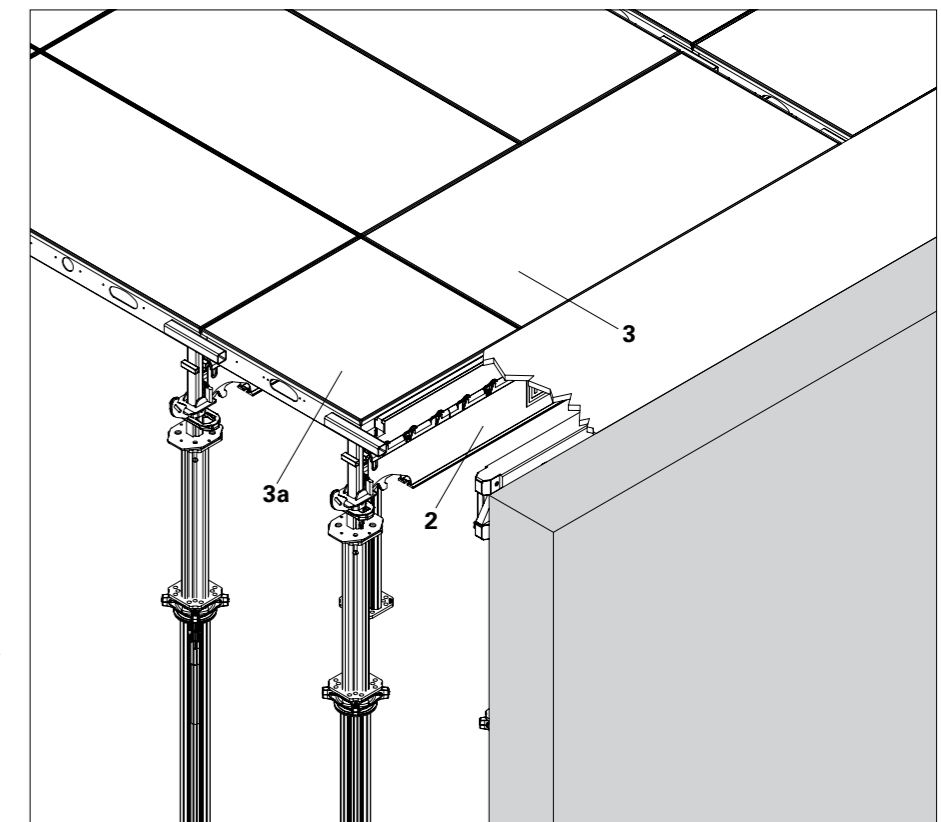

Fig. A5.32

# A5 Compensations



## Gap 0 - 12 cm

1. Place Panel SDP (3) over the Main Beam SLT (2) and secure with Panel Wedge Clip (20). (Fig. A5.33 - A5.35)
2. Nail Filler Timber SPH (12) or timber (13) up to max. 6 cm on the panel. (Fig. A5.35) Screw Filler Timber SPH (12) or timber (13) up to max. 12 cm on the panel. (Fig. A5.36)
3. Install formlining (16) and secure with nails.

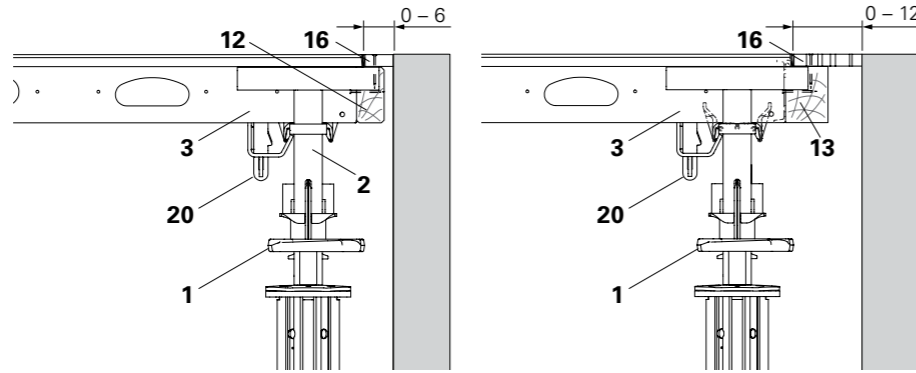

Fig. A5.33

Fig. A5.34



If panels (3) are placed over the main beam (2), the panel edge cannot laterally stabilize the main beam.

→ Secure every main beam with a Panel Wedge Clip SPKK to prevent overturning!

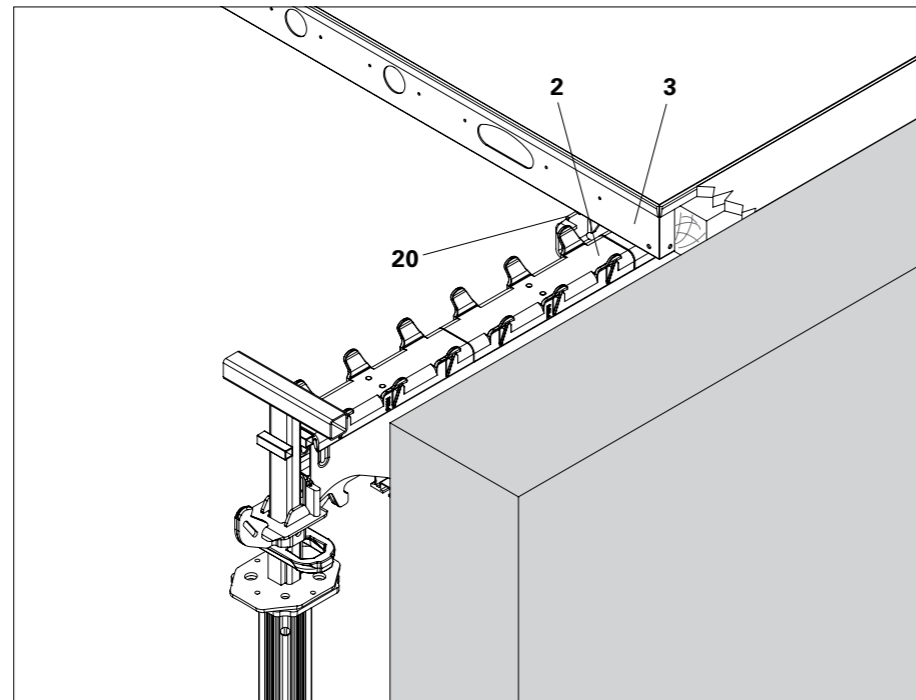

Fig. A5.35

## Gap 5 - 12.5 cm

1. Position Combihead SCK (7) with cantilever in the direction of the infill.
2. Install Panel (3).
3. Install Edge Beam SRT-2 (9) or Filler Timber SPH (12) in the Combihead (7).
4. Install formlining (16) and secure with nails. (Fig. A5.36)

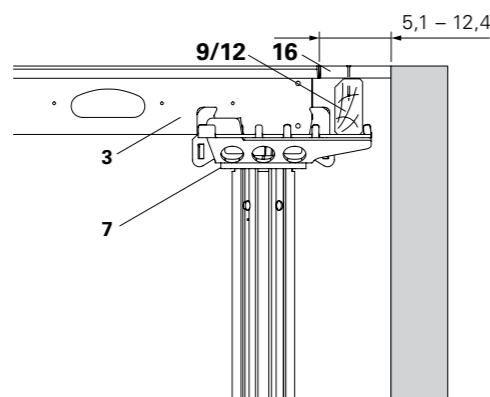

Fig. A5.36

# A5 Compensations



## Gap 12.5 - 25 cm

1. Position Combihead SCK (7) with cantilever in the direction of the infill.
2. Install Panel (3).
3. Install Edge Beam SRT-2 (9) or Filler Timber SPH (12) in the Combihead.
4. Install formlining (16) and secure with nails. (Fig. A5.37)

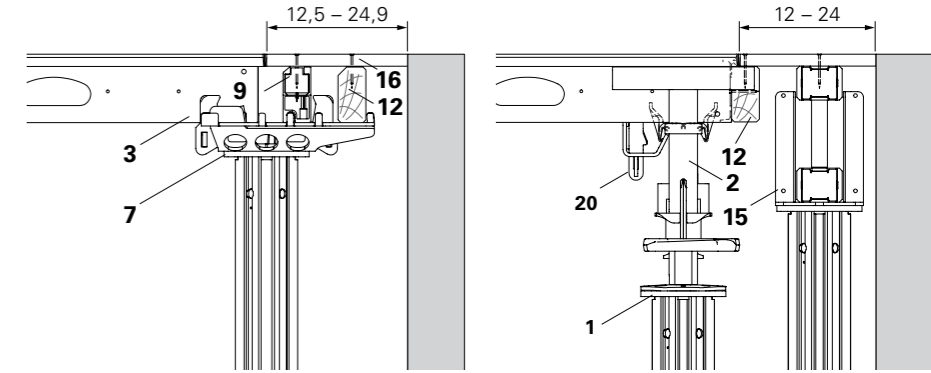

Fig. A5.37

Fig. A5.38

## Alternative

1. Place Panel SDP (3) over the Main Beam SLT (2) and secure with Panel Wedge Clip (20).
2. Screw Filler Timber SPH (12) or timber on the panel.
3. Position additional prop with Crosshead (15) and formwork girder.
4. Install formlining (16) and secure with nails. (Fig. A5.38)

## Gap 25 - 75 cm

1. Mount the Panel SDP (3) in the Main Beam (2).
2. Insert Edge Beam SRT-2 (9) in the Main Beam.
3. Position additional prop with Crosshead (15) and formwork girder.
4. Install formlining (16) and secure with nails. (Fig. A5.39 + A5.40)

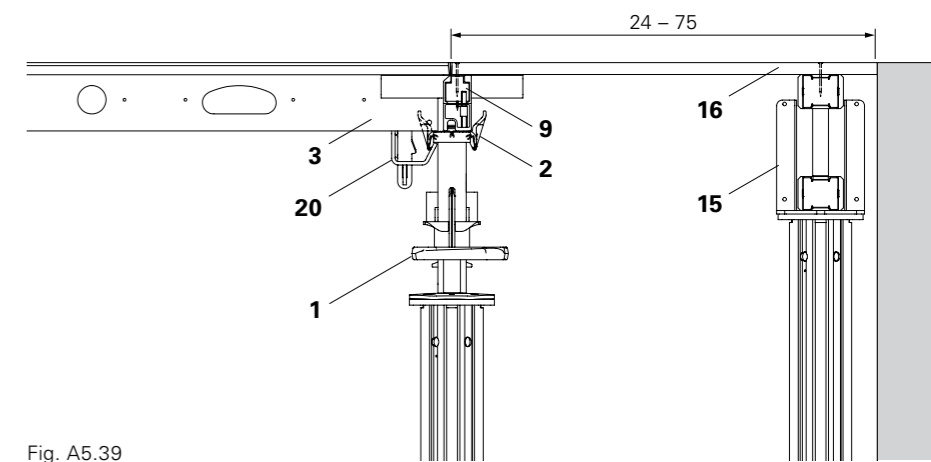

Fig. A5.39

## Components

- 1 Drophead SFK
- 2 Main Beam SLT
- 3 Panel SDP
- 6 Prophead SSK
- 7 Combihead SCK
- 9 Edge Beam SRT-2 150
- 12 Filler Timber SPH
- 13 Timber
- 15 Additional prop with crosshead and formwork girder
- 16 Plywood
- 20 Panel Wedge Clip SPKK

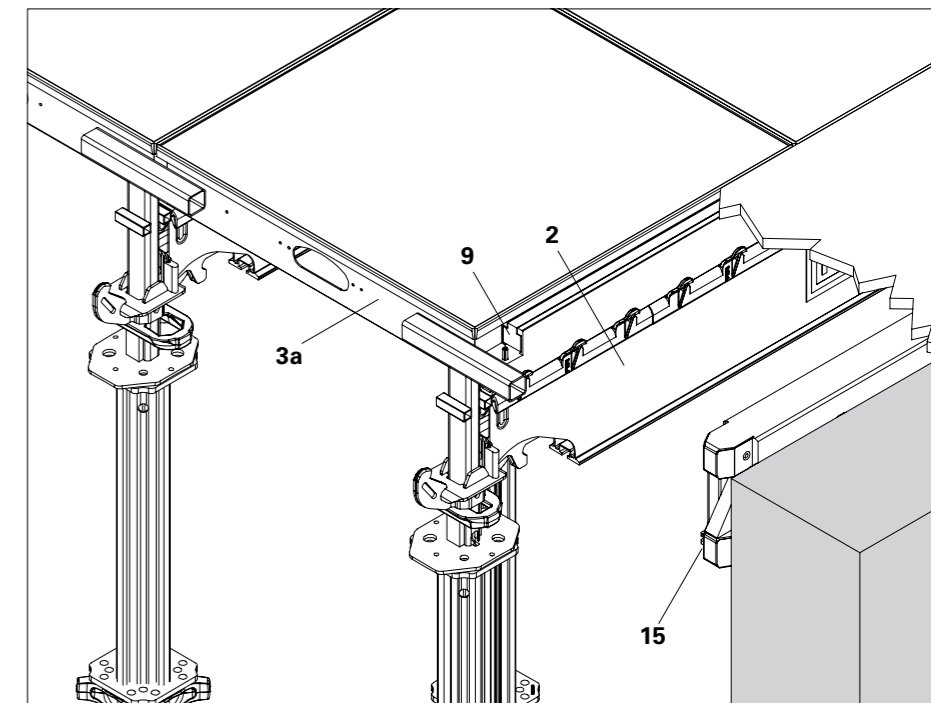

Fig. A5.40

# A6 Shuttering around columns



## 1 recessed panel

Maximum column dimensions  
x = 55 cm, y = 138 cm.



### Secure filler plates with nails!

Install Edge Beam SRT 150-2 vertically (9) or Filler Timber SPH 150 (12). During use, permissible loads must be observed; see Tables: Filler plates, forming around columns



Take into account the supporting direction of the formlining.

Alternatively:  
Install Edge Beam SRT-2 150 (9\*) in a suspended position. (Fig. A6.03)  
Flatly position Filler Timber SPH or install timber (13) supplied by the contractor.

For 27 mm formlining: height of timber = 47 mm.  
Permissible widths of influence for flat Filler Timber SPH, see Table A6.02.

### Components

- 9 Edge Beam SRT 150-2
- 10 Edge Beam SRT 75-2
- 9\* Edge Beam SRT 150-2, suspended
- 10\* Edge Beam SRT 75-2, suspended
- 12 Filler Timber SPH
- 13 Timber

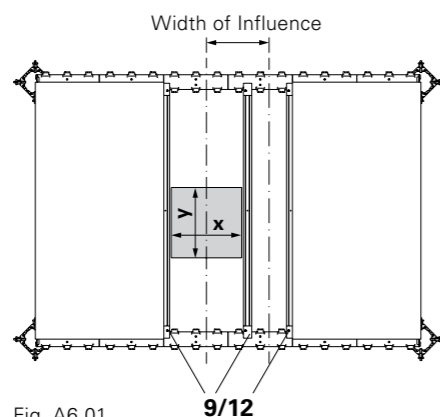

Fig. A6.01

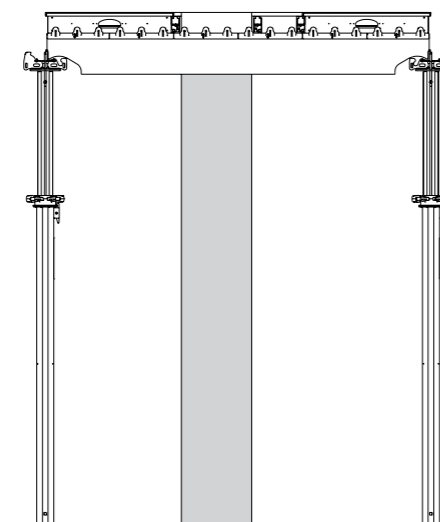

Fig. A6.02

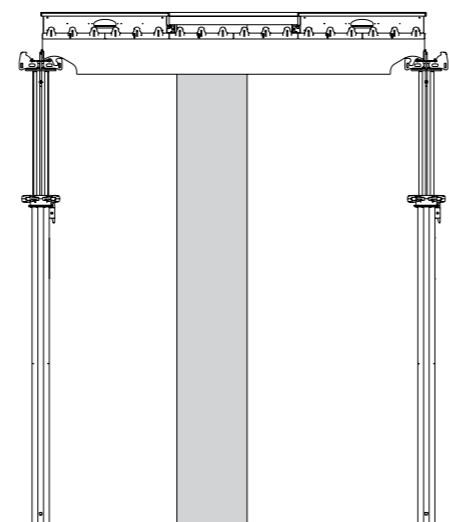

Fig. A6.03

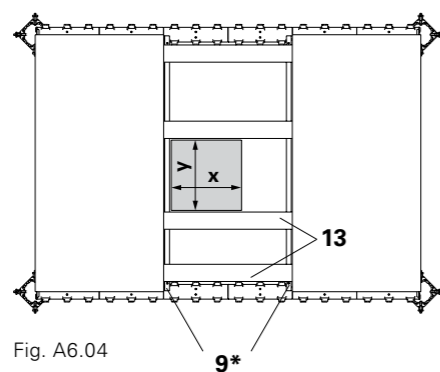

Fig. A6.04

# A6 Shuttering around columns



## 2 recessed panels

Maximum column dimensions  
x = 65 cm, y = 138 cm.



### Secure filler plates with nails!

Install Edge Beam SRT 150-2 (9) vertically at the panel edge. Insert Edge Beam SRT 150-2 (9\*) in a suspended position at the column. Likewise, insert Edge Beam SRT 75-2 (10\*) in the Edge Beam (9\*) in a suspended position. (Fig. A6.05 + A6.06)

Maximum column dimensions x = 130 cm, y = 138 cm.

Depending on the slab thickness and prop width, the transverse-positioned filler plates are to be additionally supported, see Table A6.02.

Install Edge Beam SRT 150-2 (9\*) in a suspended position. Lay Filler Timber SPH 150 (12) in a flat position. Permissible widths of influence for flat Filler Timber SPH, see Table A6.02 on next page. (Fig. A6.07 + A6.08)

With smaller cross-sections, form infill areas with Panel SDP 37.5.



Take into account the supporting direction of the formlining.

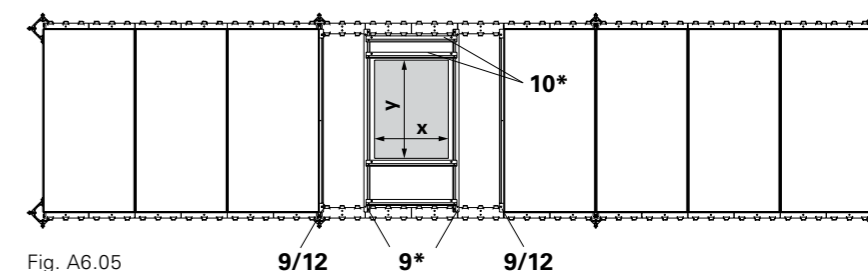

Fig. A6.05

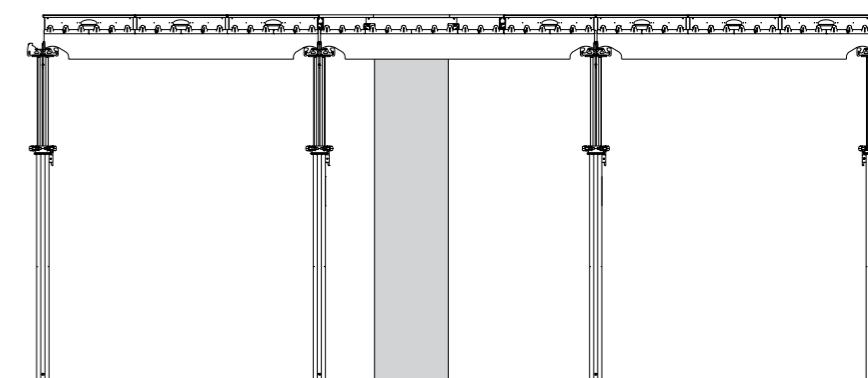

Fig. A6.06

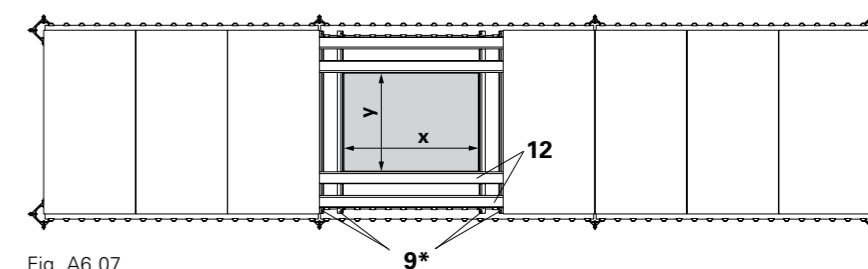

Fig. A6.07

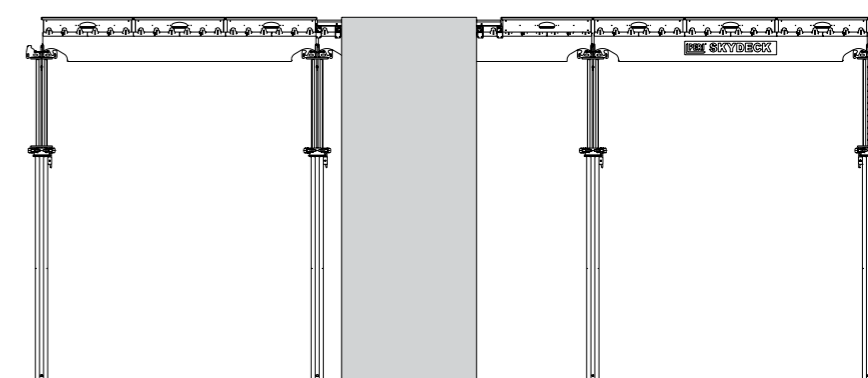

Fig. A6.08

# A6 Shuttering around columns



## 3 recessed panels

Maximum column dimensions  
x = 138 cm, y = 142 cm.



### Secure filler plates with nails!

Edge Beam SRT 150-2 (9) vertical,  
Edge Beam SRT 150-2 (9\*) suspended,  
Filler Timber SPH 150 (12) horizontally.  
(Fig. A6.09, Fig. A6.10)

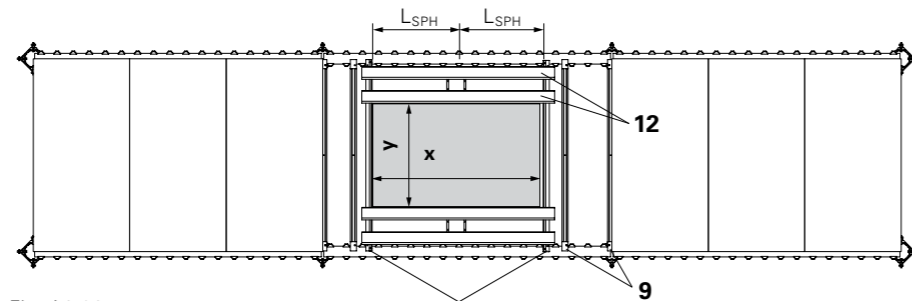

Fig. A6.09

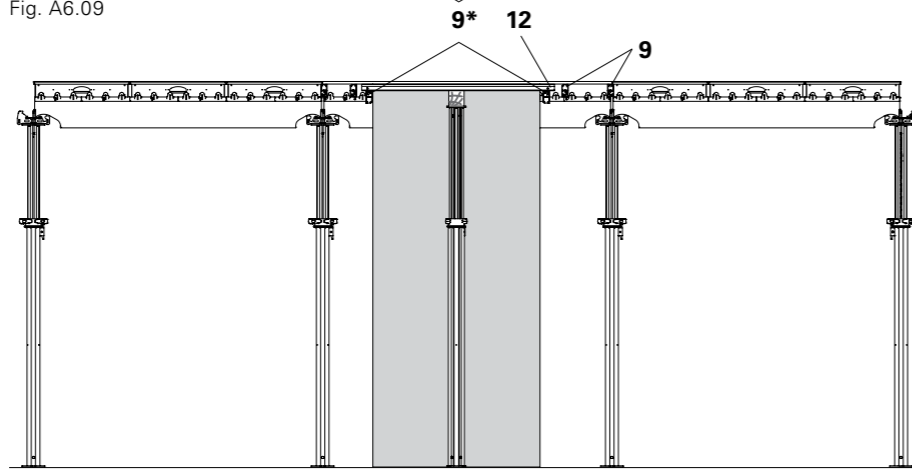

Fig. A6.10

### Additional Edge Beam SRT 150-2 (9) required with:

Slab thickness d [m]	Column side y [m]
≤ 0.20	no additional SRT
0.25	≤ 0.40
0.30	≤ 0.70
0.40	≤ 1.15

Table A6.01

For other slab thicknesses, the values are interpolated linearly.



Take into account the supporting direction of the formlining.

### Permissible width of influence of flat Filler Timber SPH, maximum deformation l/500

Slab thickness	permissible width of influence Filler Timber SPH flat e <sub>SPH,flat</sub> [cm]		
	with span LSPH [cm]		
	100	80	60
14	30	58	137
16	26	51	121
18	23	46	108
20	21	41	98
22	19	38	89
24	18	35	82
25	17	33	79
26	16	32	76
28	15	30	71
30	14	28	66
35	12	24	57
40	11	21	50
43	10	20	46

Table A6.02

# A6 Shuttering around columns



## Recessed main beams



Secure filler plates with nails!  
Secure props of the Edge Beam SRT (\*\*)  
with tripod!

### Components

- 9 Edge Beam SRT 150-2
- 6 Prophead SSK
- 11 End Support SSL

Only used if shifting the main beam axis is not desired. (Fig. A6.11, Fig. A6.12)

Additional formlining support depending on the situation on site.

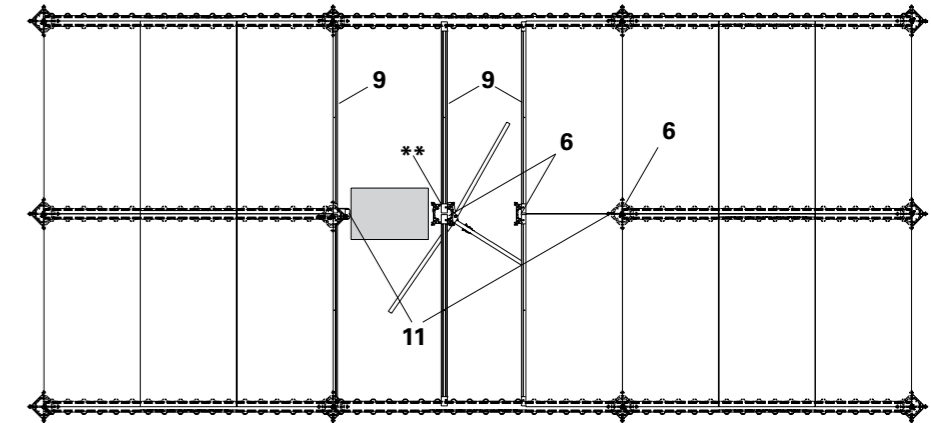

Fig. A6.11

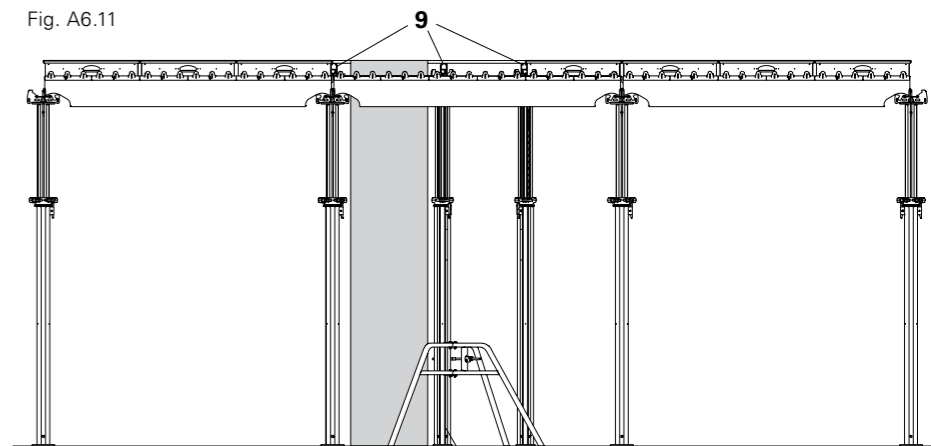

Fig. A6.12

Secure props by means of tripod.

## Shifting the main beam axis

(Fig. A6.13)



Secure shifted Main Beam SLT (\*\*)  
props using tripods!

In the area of the box out, screw timber (13) on the panel as filler support.



Take into account the supporting direction of the formlining.

### Components

- 6 Prophead SSK
- 9 Edge Beam SRT 150-2
- 9\* Edge Beam SRT 150-2 suspended
- 10 Edge Beam SRT 75-2
- 11 End Support SSL
- 12 Filler Timber SPH
- 13 Timber

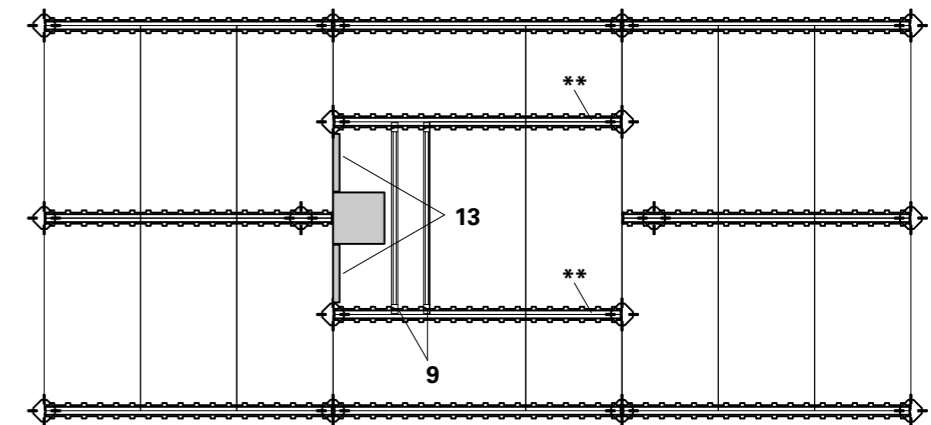

Fig. A6.13

## General



- Do not access the forming area before the formwork has been horizontally anchored!
- Do not access the cantilevers before the bracing has been securely mounted!

Formwork positioned on open building edges or concreting sections is to be secured against horizontal loads by connection to the permanent works (1) or by means of bracing where unrestrained by the permanent works (2). Cantilevers, e.g. on edge areas, must always be braced in order to prevent any tilting.

Example calculation: see Transfer of horizontal loads from a casting segment.

## Schematic representation

Influencing area, e.g. slab  $d = 25$  cm

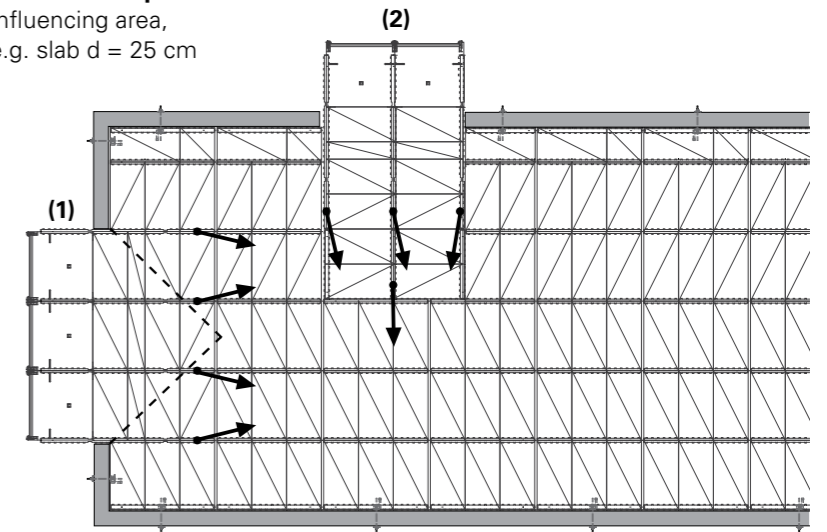

Fig. A7.02

## Bracing of the inner bay

- Maintain spacings
- Bays must be braced longitudinally and laterally where not restrained by the permanent works.

## Assembly

1. Mount Base Plate on a sufficiently load-bearing surface area, e.g. using PERI Anchor Bolt 14/20x130, Item no. 124777. Take into consideration the Technical Data Sheet!
2. Attach Anchor Chain to the panels:
  - In the longitudinal direction, attach Anchor Chain (23) to the Tension Sleeve SAO (39). (Fig. A7.03)
  - In the transverse direction, connect panels to scaffold tube (31). Wrap Chain (23) around the scaffold tube. (Fig. A7.03a)
3. Secure Anchor Chain to Base Plate using bolts, and secure bolts by means of cotter pins. (Fig. A7.03b)

Longitudinal direction

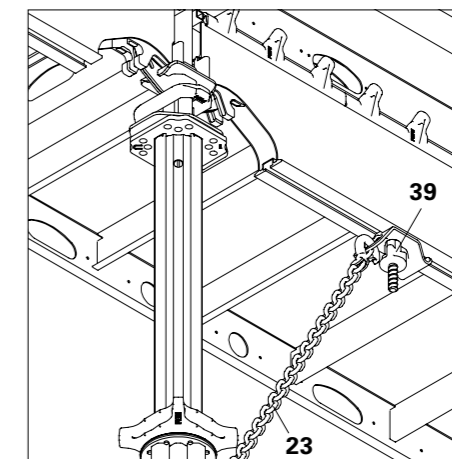

Fig. A7.03

Lateral direction

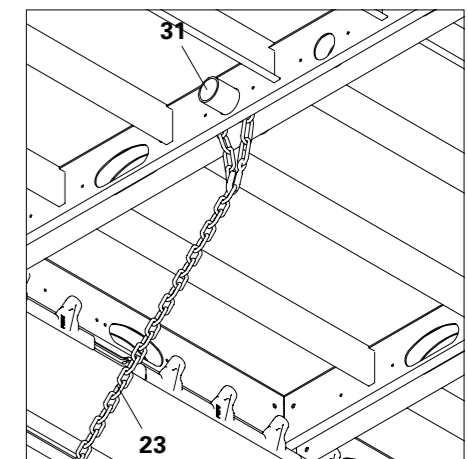

Fig. A7.03a

## Components

- |             |   |
|-------------|---|
| <b>23</b>   | Anchor Chain (permissible tension force = 3 kN) |
| <b>24</b>   | Base Plate RS                                   |
| <b>24.1</b> | Anchor Bolt PERI 14/20 x 130                    |
| <b>31</b>   | Scaffold tube / GRV Pin                         |
| <b>39</b>   | Tension Sleeve SAO                              |

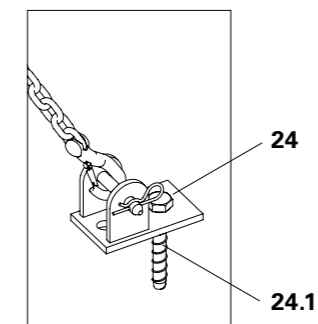

Fig. A7.03b

# A7 Horizontal bracing



## Transfer of horizontal loads from a casting segment

### Example 1 Open building edge on one side

Bracing in one building direction. (Fig. A7.05)  
Values: see Table A14.01.

#### Requirements

- Load case combination LCC 1: Concreting
- Load case combination LCC 2: Storm
- Slab thickness  $d = 25$  cm
- Panel span = 1.50 m
- 1 edge area
- 9 inner bays

#### Number of chains

- The load case combination which results in the biggest value is decisive.
- Permissible horizontal component of the tension load on the anchor chain =  $3 \text{ kN} \times \cos 60^\circ = 1.5 \text{ kN}$ . (Fig. A7.04)

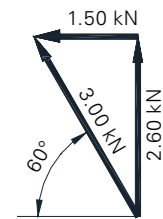

Fig. A7.04

#### Calculation

##### Load combination LCC 1 Concreting

$$1 \times H \text{ Load}_{\text{edge area}} + 9 \times H \text{ Load}_{\text{inner area}} = \sum H$$

$$1.87 \text{ kN} + 9 \times 0.27 \text{ kN} = 4.30 \text{ kN}$$

##### Load combination LCC Maximum wind

$$1 \times H \text{ Load}_{\text{edge area}} + 9 \times H \text{ Load}_{\text{inner area}} = \sum H$$

$$1.29 \text{ kN} + 9 \times 0.007 \text{ kN} = 1.353 \text{ kN}$$

##### Load from 2.5%V (BS 5975-2:2024 7.2.2.2 a)

$$1 \times H \text{ Load}_{\text{edge area}} + 9 \times H \text{ Load}_{\text{inner area}} = \sum H$$

$$1 \times 0.67 \text{ kN} + 9 \times 0.67 \text{ kN} = 6.70 \text{ kN}$$

##### Number of chains required:\*

2.5% V is the decisive value = 6.70 kN

$$n_{\text{chain}} = H / \text{perm. Horizontal tension force of chain}$$

$$= 6.70 \text{ kN} / 1.50 \text{ kN} = 4.47 \text{ chains} = \mathbf{5 \text{ chains per direction}}$$

\* Chain calculation example assumes no restraint provided by connection to the permanent works (column / walls).

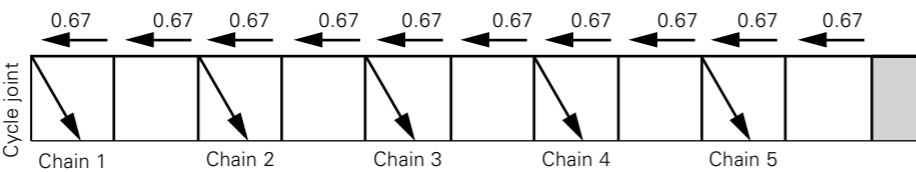

Fig. A7.05

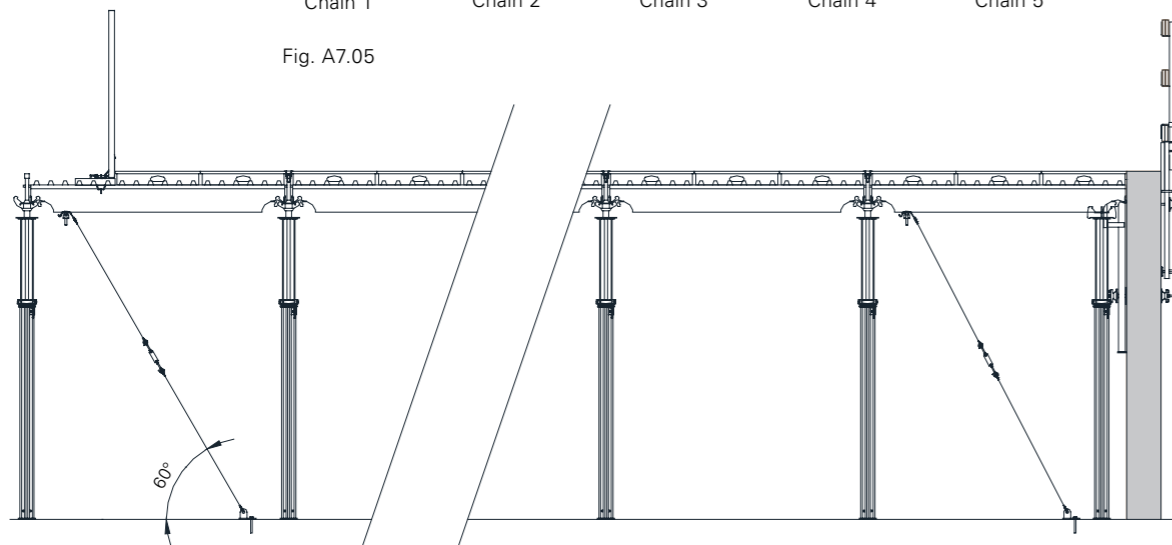

Fig. A7.06

Slab Thickness (m)	Applied Load, q (kN/m²)	Horizontal Load edge shutter (kN)		Load case combination 1: Concreting*				Load case combination 2: Maximum wind**				LCC 1: Concreting*	
		from concrete pressure		Horizontal Load <sub>inner bay</sub> [kN]		Horizontal Load <sub>edge area</sub> [kN]		Horizontal Load <sub>inner bay</sub> [kN]		Horizontal Load <sub>edge area</sub> [kN]		2.5% of Vertical Load	
		c = 1.50m	c = 0.75m	c = 1.50m	c = 0.75m	c = 1.50m	c = 0.75m	c = 1.50m	c = 0.75m	c = 1.50m	c = 0.75m		
0.250	7.83	1.17	0.59	0.27	0.13	1.87	0.94	0.007	0.004	1.29	0.65	0.67	0.34

Excerpt from Table A14.01

# A7 Horizontal bracing



### Example 2: Open building edge on both sides

Bracing in both building directions. (Fig. A7.08)  
Values: see Table A14.01.

#### Requirements

- Load case combination LFK 1: Concreting
- Load case combination LFK 2: Storm
- Slab thickness  $d = 25$  cm
- Panel span = 1.50 m
- 2 edge areas
- 8 inner bays

#### Number of chains

- The load case combination which results in the biggest value is decisive.
- Permissible horizontal component of the tension load on the anchor chain =  $3 \text{ kN} \times \cos 60^\circ = 1.5 \text{ kN}$ . (Fig. A7.04)

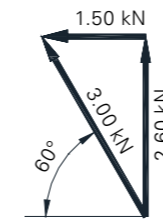

Fig. A7.04

#### Calculation

##### Load combination LCC 1 Concreting

$$2 \times (H \text{ Load}_{\text{edge area}} - H \text{ Load}_{\text{edge shutter}}) + 8 \times H \text{ Load}_{\text{inner area}} = \sum H$$

$$2 \times (1.87 \text{ kN} - 1.17 \text{ kN}) + 8 \times 0.27 \text{ kN} = 3.56 \text{ kN}$$

(H Load<sub>edge shutter</sub> forces are opposing forces and are therefore deducted)

##### Load combination LCC Maximum wind

$$2 \times H \text{ Load}_{\text{edge area}} + 8 \times H \text{ Load}_{\text{inner area}} = \sum H$$

$$2 \times 1.29 \text{ kN} + 8 \times 0.007 \text{ kN} = 2.636 \text{ kN}$$

##### Load from 2.5%V (BS 5975-2:2024 7.2.2.2 a)

$$2 \times H \text{ Load}_{\text{edge area}} + 8 \times H \text{ Load}_{\text{inner area}} = \sum H$$

$$2 \times 0.67 \text{ kN} + 8 \times 0.67 \text{ kN} = 6.70 \text{ kN}$$

##### Number of chains required:\*

2.5% V is the decisive value = 6.70 kN

$$n_{\text{chain}} = H / \text{perm. Horizontal tension force of chain}$$

$$= 6.70 \text{ kN} / 1.50 \text{ kN} = 4.47 \text{ chains} = \mathbf{5 \text{ chains}}$$

\* Chain calculation example assumes no restraint provided by connection to the permanent works (columns / walls).

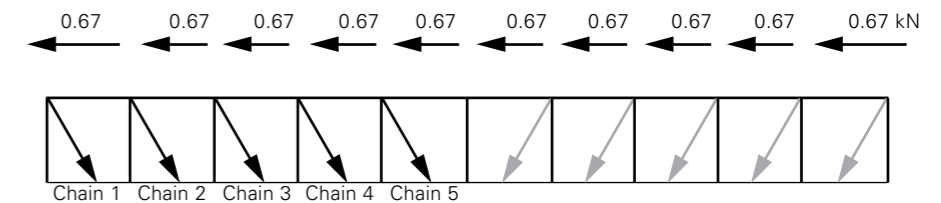

Fig. A7.07

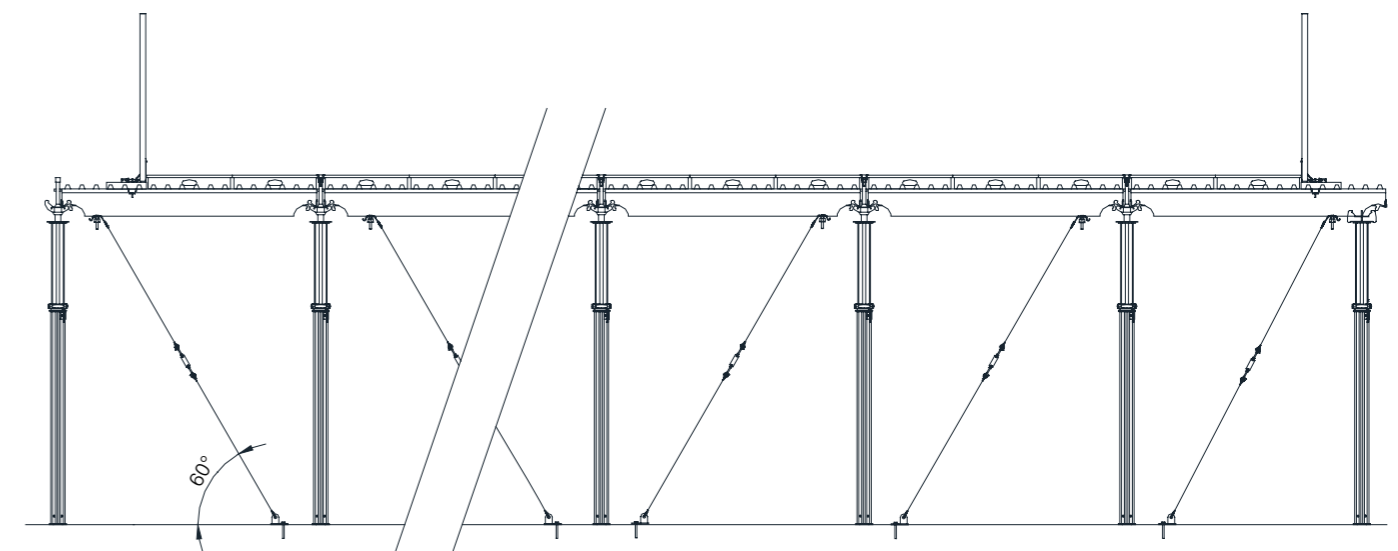

Fig. A7.08

## Bracing on open building edges to prevent tipping



Horizontal loads must be additionally taken into consideration and transferred, e.g. with bracing; see Section A7.

### Cantilevers with SKYDECK Platforms SDB

Mount Tension Sleeve SAO (39) on main beam. Distance to inner prop max. 50 cm. Brace using Anchor Chain (23), Base Plate (24) and Anchor Bolt (24.1). (Fig. A8.01)  
Max. slab overhang: 37.5 cm. (Fig. A8.01 + A8.02)

### Corner table:

The Main Beams SLT "A + B" receive 2-fold horizontal load from the wind and 1-fold load from the stopend formwork pressure. Additional bracing is required.

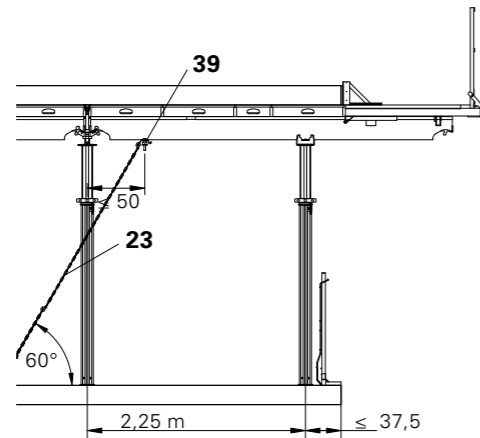

Fig. A8.01

### Components

- |             |   |
|-------------|---|
| <b>23</b>   | Anchor Chain (permissible tension force = 3 kN) |
| <b>24</b>   | Base Plate RS                                   |
| <b>24.1</b> | Anchor Bolt PERI 14/20 x 130                    |
| <b>39</b>   | Tension Sleeve SAO                              |
| <b>45</b>   | SKYDECK Platform SDK                            |



Fig. A8.03 shows only bracing from load case Tilting. Take into account Section A9 SKYDECK Platforms!

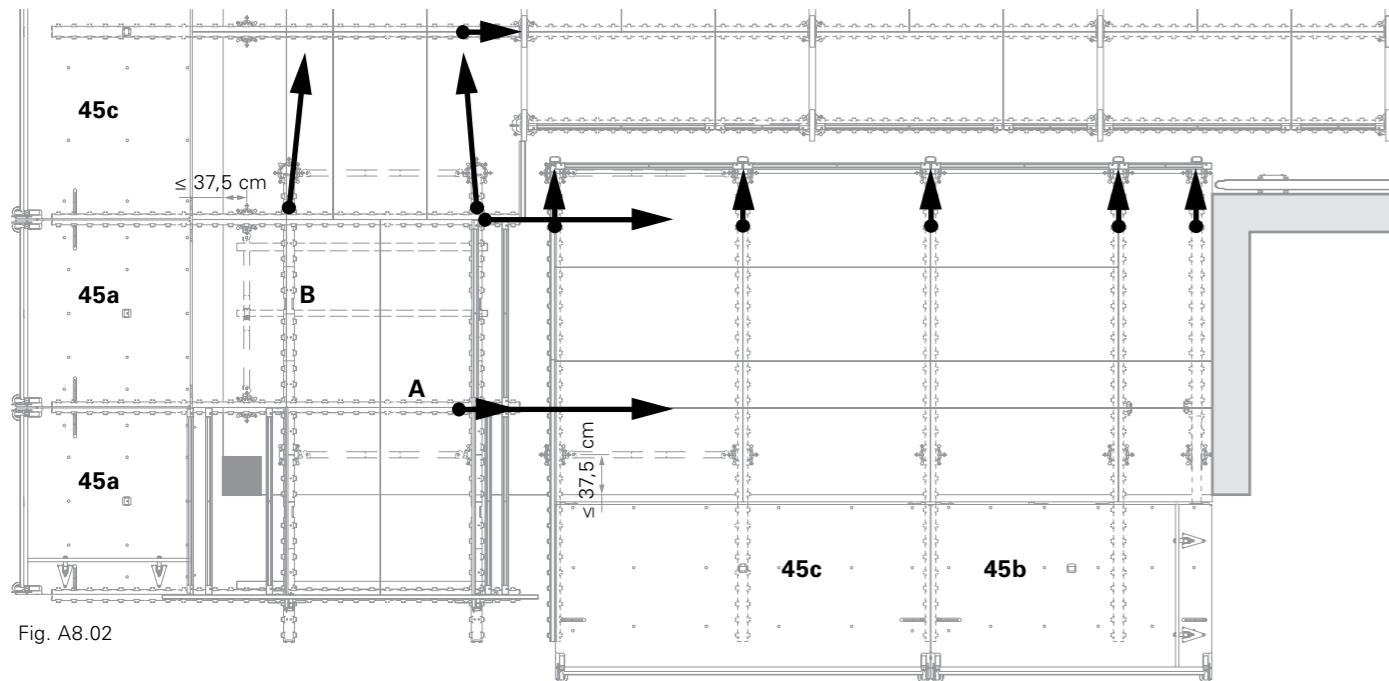

Fig. A8.02

## Guardrails with Handrail Unit SD

- SD 75
- SD 150

The SKYDECK Handrail Unit SD secures site personnel working on a casting segment against falling in the main bay direction.



**Risk of falling!**  
During assembly of the Handrail Unit, measures must be taken to prevent falling, e.g. PPE!

### Assembly



A free length of at least 35 cm must be available on the main beam in order to be able to mount a Handrail Unit SD. (Fig. A8.04a)

1. Pull lug (25.1) upwards. (Fig. A8.07)
2. Move the Handrail Unit SD (25) firstly in the direction of the building edge (I.) and then downwards (II.) (Fig. A8.04a)
3. Place Handrail Unit SD with the hooks (25.2) between the two teeth (2.2) which are free on the main beam. → The lug falls downwards. Hooks engage and are secured. If the lug is not completely down, then press lug (25.1) downwards by stepping on it. (Fig. A8.05) The Handrail Unit is installed. (Fig. A8.06)



- Is the lug completely folded down?
- Do the hooks enclose the teeth of the main beam? (Fig. A8.05)

### Dismantling

1. Pull lug (25.1) upwards. (Fig. A8.07) → Hooks are released.
2. Lift out Handrail Unit SD (25) and place in Pallet Handrail Unit SD 150 x 75.

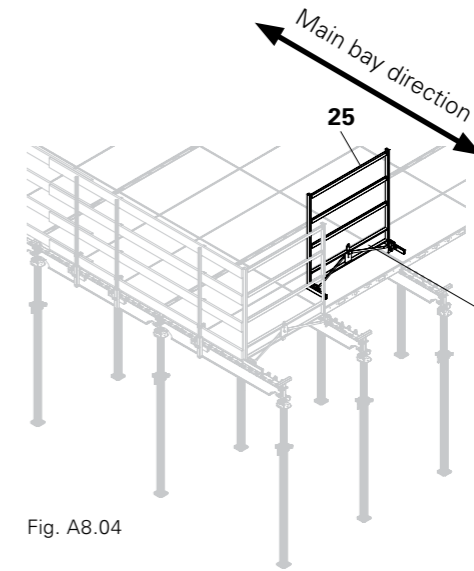

Fig. A8.04

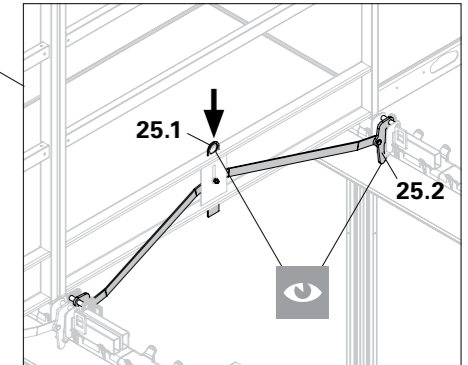

Fig. A8.05

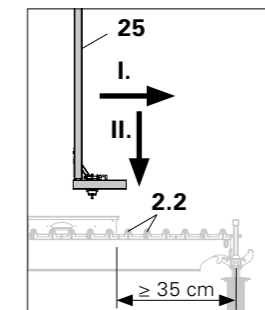

Fig. A8.04a

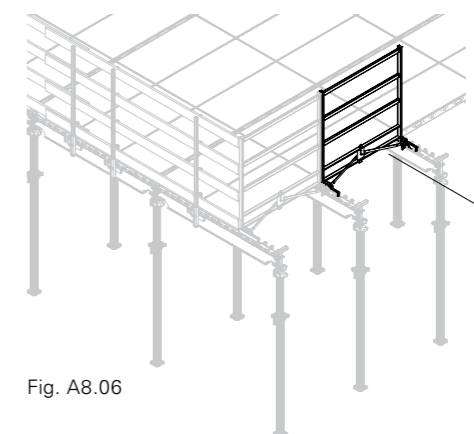

Fig. A8.06

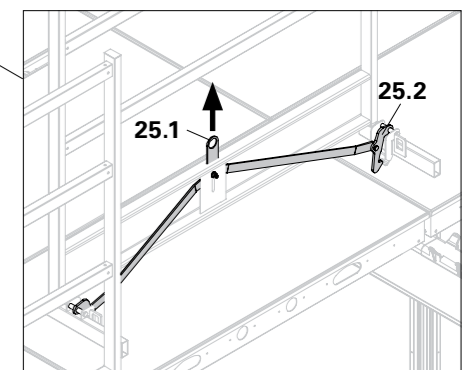

Fig. A8.07

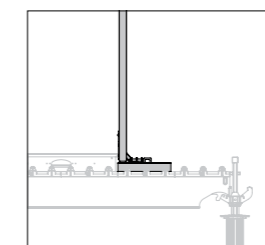

Fig. A8.06a

## SKYDECK Guardrail Holder SGH and Guardrail Post SGP



**Risk of falling!**  
During assembly, measures must be taken to prevent falling, e.g. PPE!

### Assembly

Continuously mount Guardrail Holders SGH (17) between the panels. To do so, place the guardrail holder laterally offset on the main beam and slide in. Spacing max. 1.55 m.



Wind safeguard measure: with wind speeds > 90 km/h, remove the top guardrail board. Adapt working area accordingly to suit changed guardrail situation.

After the last row of panels, mount the Guardrail Holder SGH for the End Guardrail Frame on all main beams:

1. Start with the guardrail holder on the outer right-hand side (17.1) - as viewed when standing in front of the formwork. Mounting bar is pointing to the left.
2. Mount all other guardrail holders (17) with the mounting bar pointing to the right. (Fig. A8.09) The mounting bars overlap in the first bay.
3. Insert guardrail posts (18).
4. Insert guardrail boards and secure with nails. (Fig. A8.10)

### Components

- 17 Guardrail Holder SGH
- 18 Guardrail Post SPG
- 20 Panel Wedge Clip SPKK



Regarding the tightness of the panel joints, e.g. for casting segments/setting of stopends, push the panels tightly together and secure on the last main beam with Panel Wedge Clips SPKK (20).

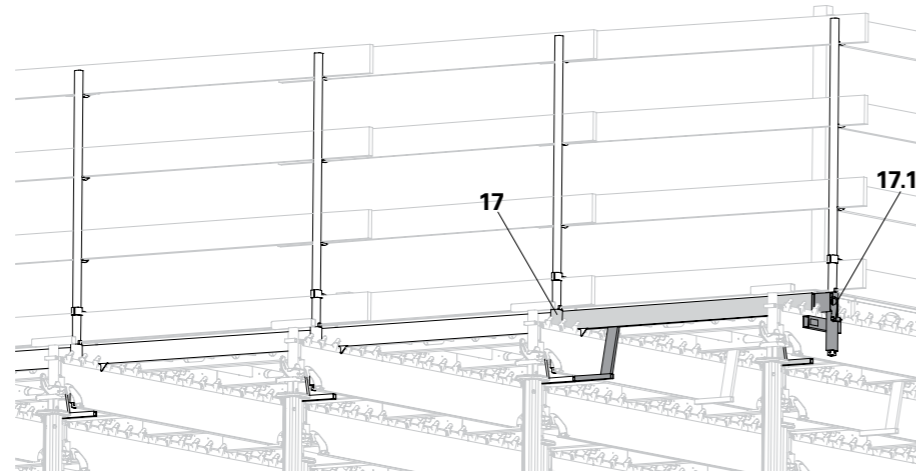

Fig. A8.09

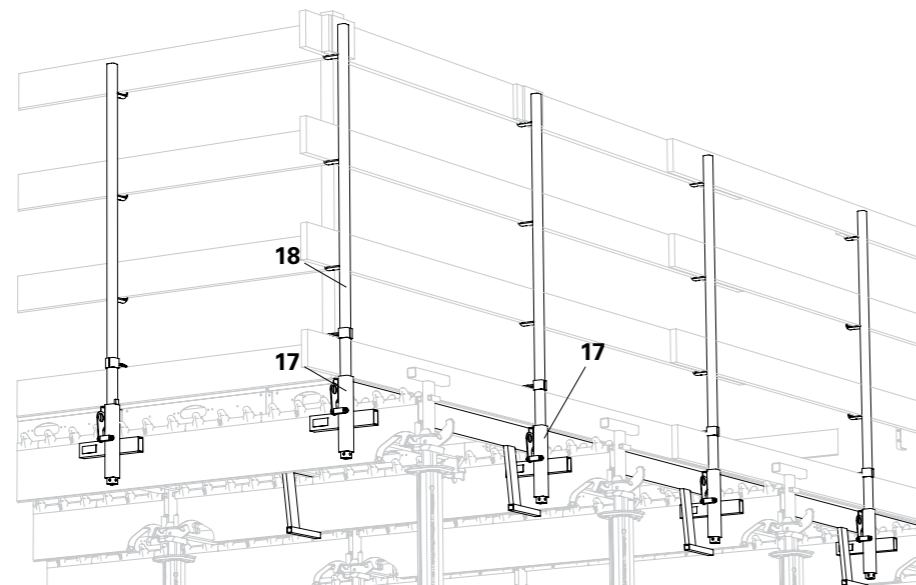

Fig. A8.10

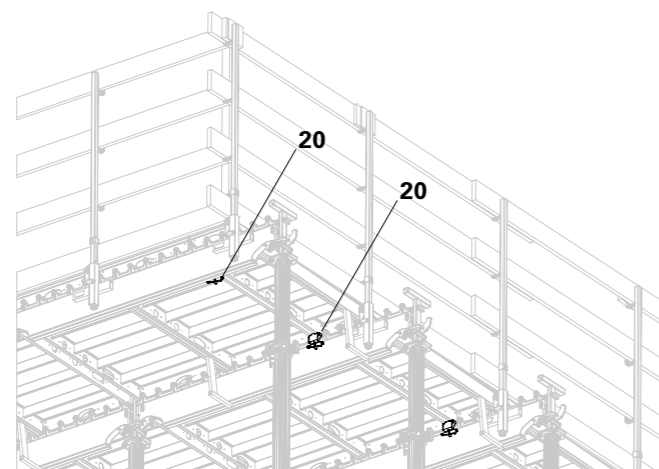

Fig. A8.11

## Overview

The SKYDECK Platform SDB is a prefabricated, foldable scaffold platform for use as a working scaffold following DIN EN 12811, Load Class 2, with a permissible load of 1.5 kN/m<sup>2</sup> (150 kg/m<sup>2</sup>). It secures the open building edges of the SKYDECK Slab Formwork.

Assembly of the slab formwork in connection with SKYDECK Platform SDB is carried out in four areas. (Rom. I - IV) The sequence must be maintained. (Fig. A9.01)



### Risk of falling!

- Ensure that end-to-end side protection is installed on slabs that have been completed!
- Cantilevers should not have formwork erected or be stepped on before being firmly secured with tension chains.
- Work to be carried out by qualified personnel only!



When using SKYDECK Platforms, no safety scaffold is required for the levels below.

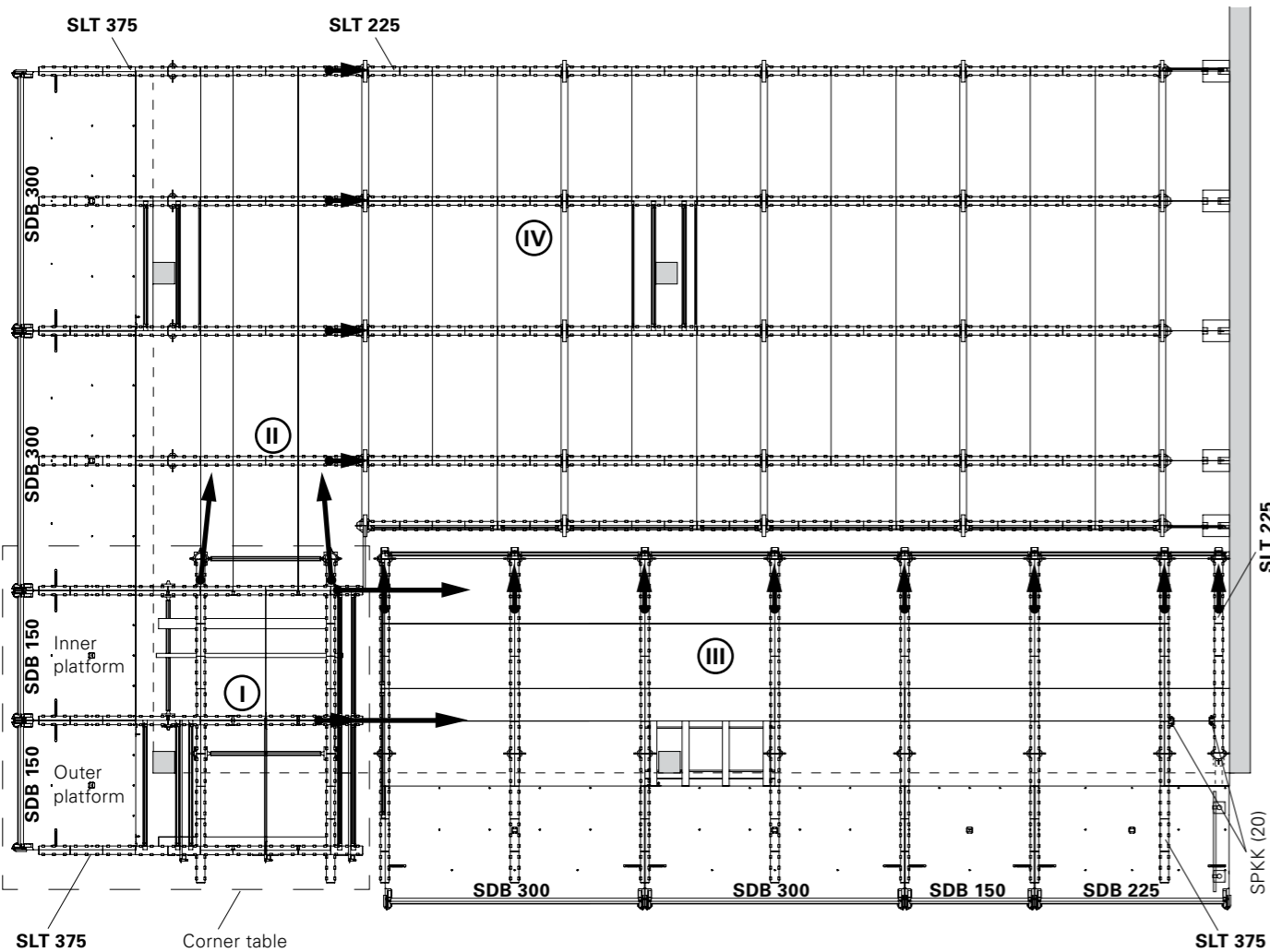

Fig. A9.01

## Corner table (Area I)



### Risk of falling!

- Ensure that end-to-end side protection is installed on slabs that have been completed!

Begin forming operations on a free building corner. The corner table is assembled on the previously concreted slab in the inside of the building. Subsequently, position in the corner (Area I) and secure against tipping. (Fig. A9.01)

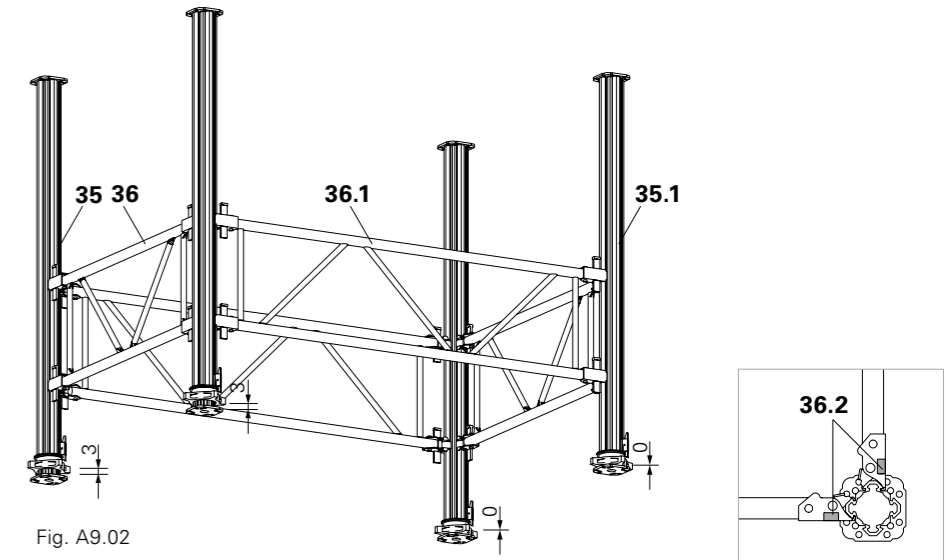

Fig. A9.02

## Frame assembly

1. Spindle out the MULTIPROP Props MP (35) 3 cm on a narrow side. The two props opposite (35.1) are not spindled out. As a result, the height difference resulting from the different installations of the main beam is compensated. The exact height adjustment takes place later.
2. Four MULTIPROP Props are placed in a 1.50 m x 2.25 m grid with the spindles (inner tube) downwards and formed into a base frame using MULTIPROP MRK 150 (36) and MRK 225 (36.1) Frames. (Fig. A9.02) Mount the frame at the same level above the slab. Locking wedges (36.2) are facing outwards.
3. Attach two Propheads SSK (6) on the extended props.

Main Beam Support SSK (shown without table connector)

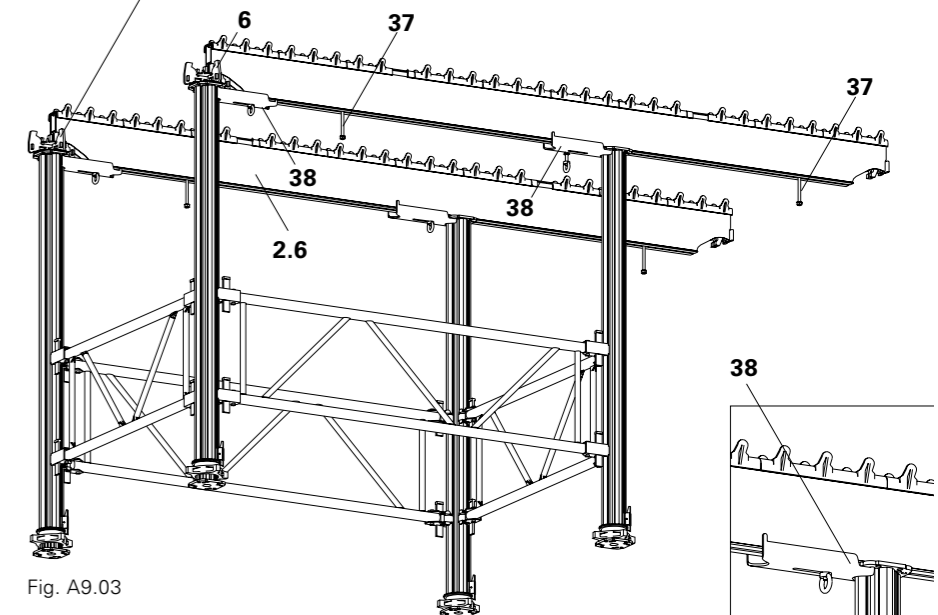
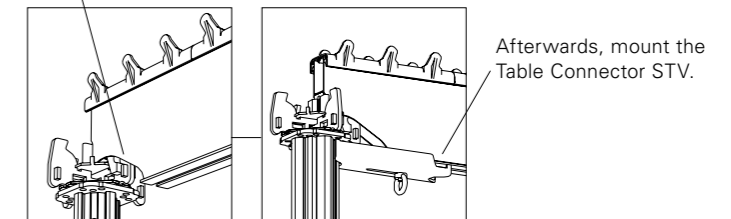

Fig. A9.03

## Assembly of the main beams

1. Insert each Main Beam SLT 375 into a main beam groove:
  - Use two Bolts M12 x 140 DIN 6914 (37) for fixing timbers 8/12.
  - 2 x Table Connector STV (38).
  - Sequence and alignment of bolts and table connectors: see Fig. A9.03.
2. Mount Main Beam SLT 375 (2.6) and set the beam down on the front props.
3. Push the Table Connector STV up to the MULTIPROP Props and make a secure connection by tightening the ring bolts. (Fig. A9.03a)

## Components

- 2.6 Main Beam SLT 375
- 6 Prophead SSK
- 35 MULTIPROP Prop MP
- 36 MULTIPROP Frame MRK
- 37 Bolt M12 x 140
- 38 Table Connector STV

Fig. A9.03a

4. Insert two SAO Tension Sleeves approx. 1 m in each of the grooves of 3 Main Beams SLT 375. Tension sleeves later lie between the two bottom main beams.
5. Position Main Beams SLT 375 (2.6) transversely with 1.50 m spacings on the already assembled main beams. At the rear, all three beams have an overhang of 37.5 cm. The first beam is laterally inset 37.5 cm on the lower beam.
6. Insert additional Tension Sleeves SAO (39) on both sides as far as the bottom main beams. Push the previously mounted tension sleeves inwards against the bottom main beams. (Fig. A9.04a)
7. Connect the beams together by tightening the tension sleeves.

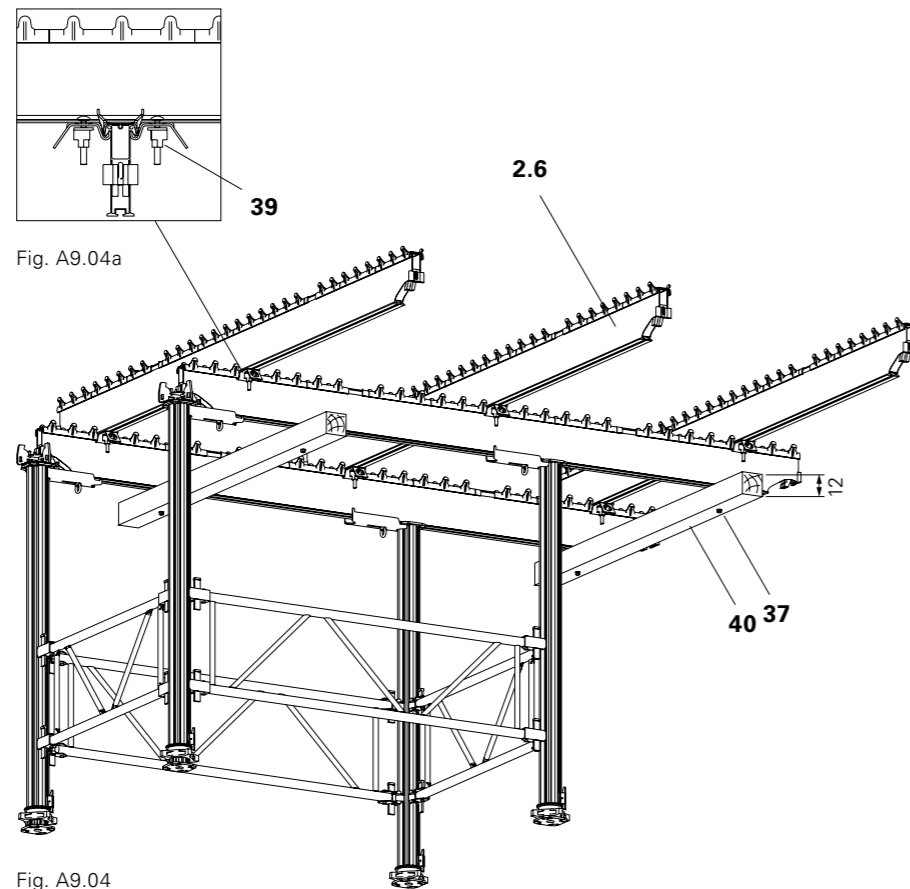

### Mounting the timbers

Timbers are required for load distribution when directly reaching under with the transportation fork.

1. Attach 2 timbers with min. 8/12/225 (40) (supplied by contractor) to the hex. bolts using nuts and washers. (Fig. A9.04)
2. Diagonally brace the timbers.

### Insert panels

The first row of panels (3) is inset 37.5 cm and begins in the centre aligned to the first bottom main beam.

1. Insert the SDP 150 x 75 panels from below and secure to the main beams with two SPK Panel Clamps per panel.
2. The middle panels are additionally fixed to the front outer panels using two Panel Wedge Clamps SPKK (20) each.
3. On the side cantilevered slab edge: install the Guardrail Holder SGH.
4. Mount Guardrail Posts SGP and hand-rail boards as anti-fall protection. (Fig. A9.05)

### Components

- 2.6 Main Beam SLT 375
- 17 Guardrail Holder SGH
- 20 Panel Wedge Clip SPKK
- 21 Panel Clip SPK
- 37 Bolt M12 x 140
- 39 Tension Sleeve SAO
- 40 Timber

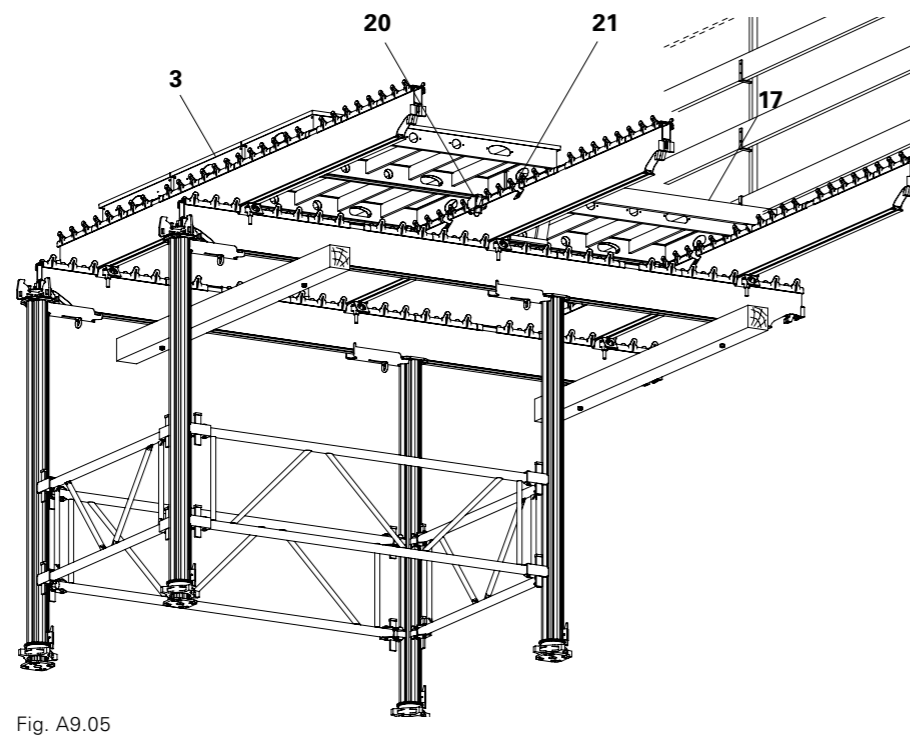

Fig. A9.05

### Supporting the top main beams

1. Insert Table Connector STV into the longitudinal grooves of the top main beams (2.6) which are later positioned in the building.
2. Fix 2 MULTIPROP Props MP (35) 1.50 m from the cantilevered girder end using the Table Connector STV (38).
3. Brace the MULTIPROP Props MP with MULTIPROP Frame MRK 150 (36).
4. Connect the Frames MRK 150 to the Frames MRK 225 (36.1) with at least one scaffold tube L = 2.25 m (31) and three scaffold couplings. (Fig. A9.06)
5. Mount the inner SKYDECK Platform SDB (45). (Fig. A9.06a)
6. Insert Panels SDP.

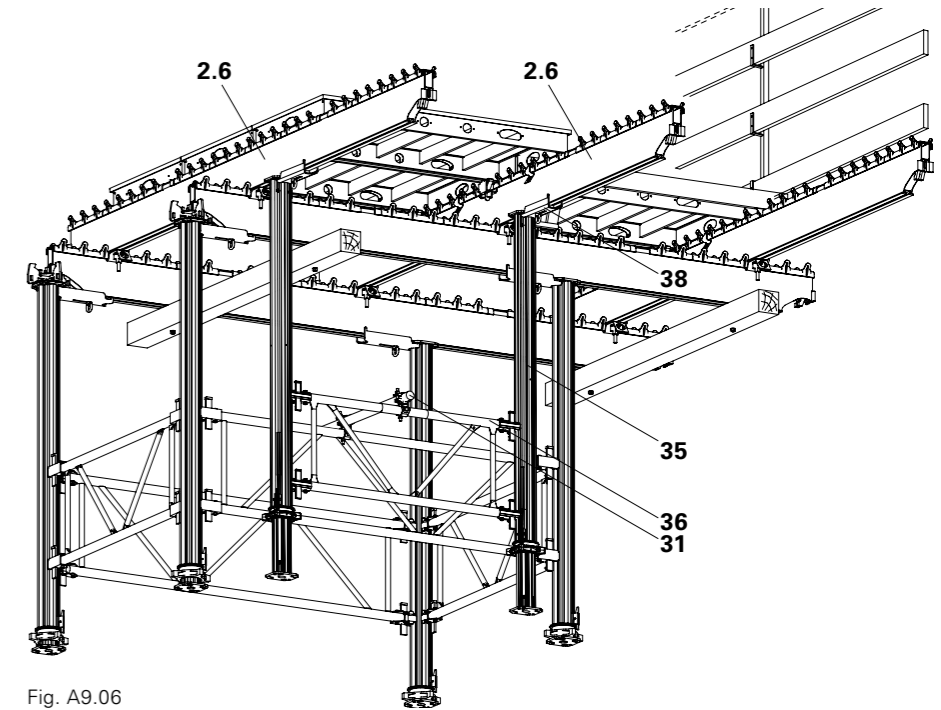

Fig. A9.06

### Position corner table



### Follow Instructions for Use, SKYDECK Lifting Fork!

1. Raise the corner table using the SKYDECK Transportation Fork and extend the Props MP to the required length.
2. Position the corner table at the corner of the building so that the front MULTIPROP Props MP (35) are as close as possible to the edge of the building. (Fig. A9.06a)



### Risk of falling!

- Do not erect formwork or step on corner table before the tension chains are securely fixed.
- Do not close the filler areas until the corner table has been securely fixed and SKYDECK platforms have been attached.

### Components

- 2.6 Main Beam SLT 375
- 31 Scaffold Tube
- 35 MULTIPROP Prop MP
- 36 MULTIPROP Frame MRK
- 38 Table Connector STV
- 45 SKYDECK Platform SDK

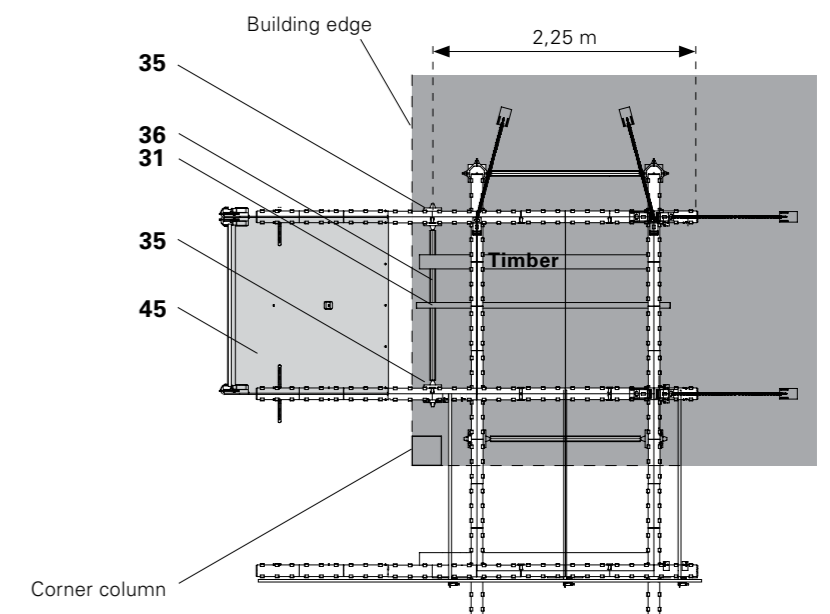

Fig. A9.06a

## Tensioning the corner tables



Use anchor chains for securing the tables to the floor.

1. Attach one tension chain (23) to the outer Table Connector STV (38) on each of the bottom Main Beams SLT 375, and diagonally tension.
2. Attach one tension chain (23.1) to the Tension Sleeve SAO on the first top and inner Main Beam SLT 375, and diagonally tension.
3. On the middle, top main beam, attach two tension chains to the Tension Sleeves SAO. Diagonally (23.2) tension the first tension chain; the second tension chain (23.3) is vertically tensioned. (Fig. A9.07 + A9.07a)



**Risk of falling!**  
During assembly, measures must be taken to prevent falling, e.g. PPE!

4. Mount the SKYDECK Platform SDB (45): see A9 Platform installation.
5. Close the filler areas: see A5 Compensations and A6 Shuttering around columns.

## Components

- 23 Tension chain
- 38 Table Connector STV
- 45 SKYDECK Platform SDK

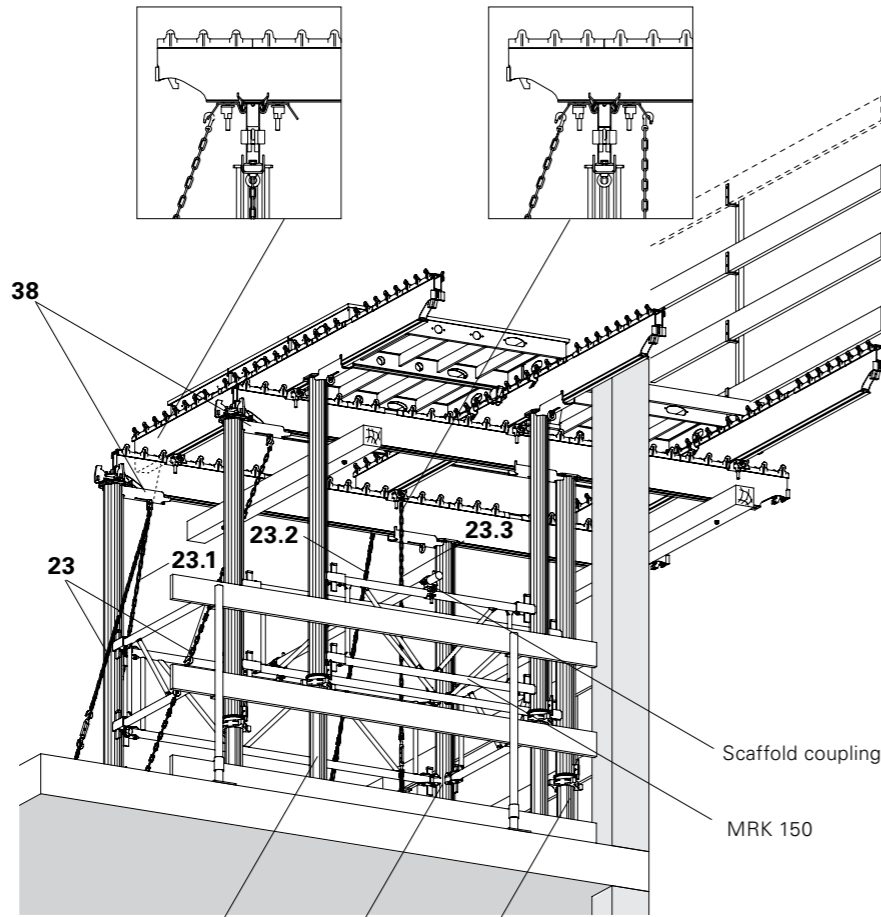

Fig. A9.07 additional prop prop additional prop

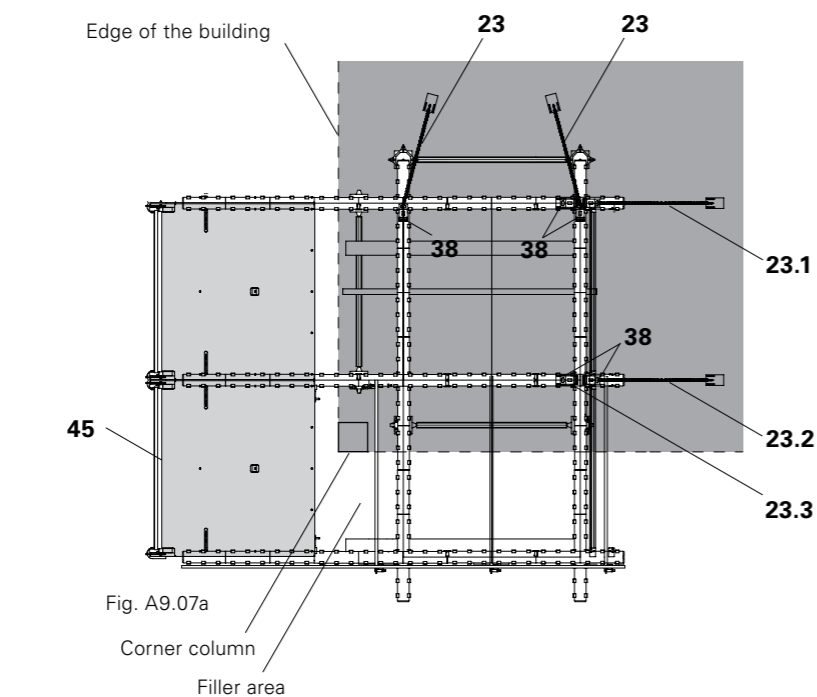

Fig. A9.07a

Corner column  
Filler area

## Cantilevers (Area II)



**Risk of falling!**  
– Ensure that end-to-end edge protection is installed on slabs that have been completed!  
– Cantilevered platforms should not have formwork erected or be stepped on before being firmly secured with tension chains.

Continue forming after erecting the corner table (Area I) in Area II with main beams. Main beams are laid parallel to the upper beams of the corner table. Start shuttering at the edge of the slab.

1. Place prop with Drophead SFK (1) at slab edge and secure with tripod.
2. Connect Main Beam SLT 375 (2.6) and support by means of a second prop with Prophead SSK (6) after 2.275 m at the edge of the building. (Formed exclusively with prophead; position front prop at a distance of 2.25 m).
3. Mount Tension Sleeve SAO (39) in the main beam groove. Distance  $\leq 50$  cm from the non-cantilevered end.
4. Attach tension chain (23) with turnbuckle to the eye at the top, and anchor to the ground by means of a base plate (24). (Fig. A9.08)
5. Bay by bay immediately install 3 Panels 150 x 75 (3) and 1 Filler Panel 150 x 37.5 (3a) from below as far as the platform support (2.7) of the Main Beam SLT 375. For example, with the PERI Stripping Cart ASW 465.



- Depending on the thickness of the slab, position additional props and girders at corresponding distances.
- In those areas where the 1.50 m grid is interrupted by columns etc., a 75 cm bay may be installed. Tension Sleeves SAO are used to secure against tipping.

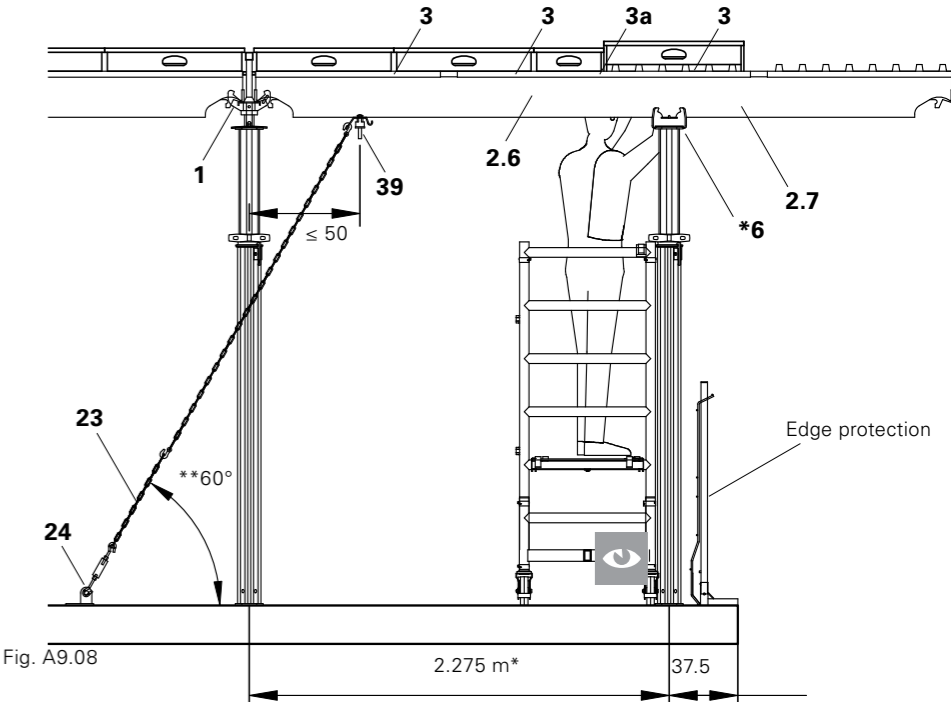

Fig. A9.08

\* with the installation of Frames MRK 230 or MRK 225: turn the Prophead SSK by 45°.  
\*\* Chains at 60° bracing angle for tipping and horizontal load restraint

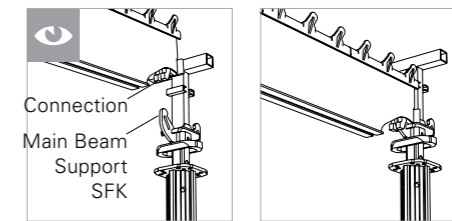

Fig. A9.09



- Are the props in line with the props of the corner table? (Fig. A9.08)
- Is the Main Beam SLT mounted centrally in the beam support of the heads? Does the main beam connection enclose the main beam support of the head? (Fig. A9.09)

## Components

- 1 Drophead SFK
- 2.6 Main Beam SLT 375
- 2.7 Platform Support
- 3 Panel SDP 150 x 75
- 3a Panel SDP 150 x 37.5
- 6 Prophead SSK
- 10 Edge Beam SRT
- 19 Timber
- 20 Panel Wedge Clip SPKK
- 23 Tension chain
- 24 Base Plate RS
- 39 Tension Sleeve SAO

## Open edge areas (Area III)

Start shuttering on structural constraint points (e.g. wall, casting segment) and work towards the corner table, Area II.

## Slab area (Area IV)

When all edge areas are formed, the slab surface Area IV is formed in the usual way with SKYDECK.



Regarding the tightness of the panel joints, e.g. for casting segments/setting of stopends, push the panels tightly together and secure on the last main beam with Panel Wedge Clips SPKK (20).

## Components

- 2 Main Beam SLT 225
- 2.6 Main Beam SLT 375
- 10 Edge Beam SRT
- 19 Timber
- 20 Panel Wedge Clip SPKK
- 45 SKYDECK Platform SDB 300
- 46 SKYDECK Platform SDB 150
- 47 SKYDECK Platform SDB 225

## Infill areas



### Risk of falling!

- Cantilevers should not have formwork erected or be stepped on before being firmly secured with tension chains.
- When working on the slab formwork, measures must be taken to prevent falling, e.g. PPE.
- Clearly mark unsecured building edges!

Close infill areas in the inner area, close infill areas at unsecured building edges after the platforms have been installed.

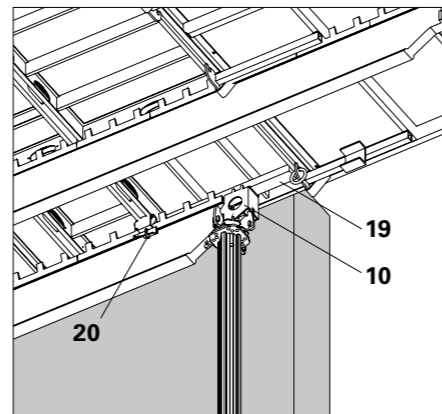

Fig. A9.10

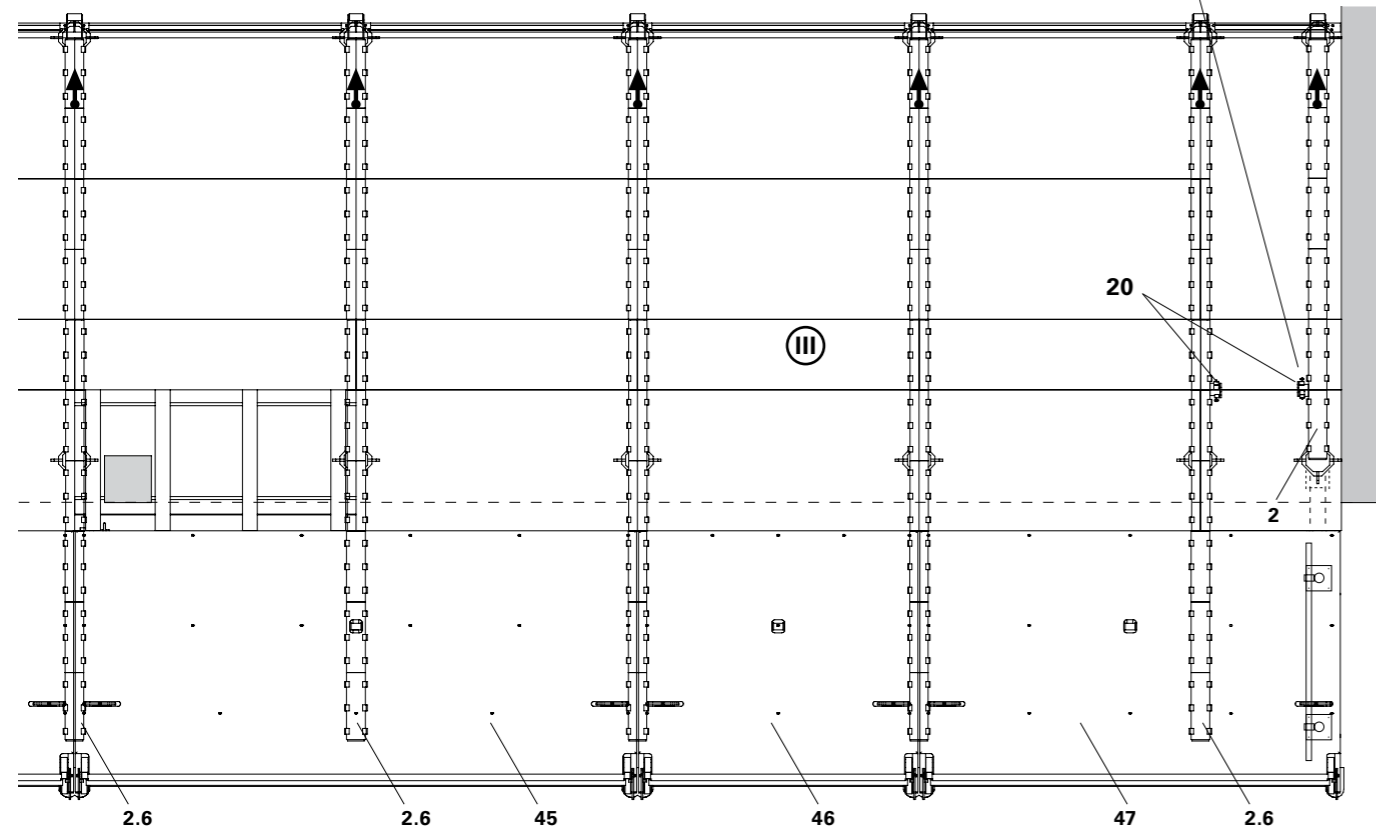

Fig. A9.11

## Platform installation



### Risk of falling!

- Cantilevers should not have formwork erected or be stepped on before being firmly secured with tension chains.
- When working on the slab formwork, measures must be taken to prevent falling, e.g. PPE.
- Clearly mark unsecured building edges!

Begin with the platform assembly in one area in which there is no risk of falling to the rear or to one side (e.g. Area II, see Ground Plan Fig. A9.01).

1. With the help of the Shuttering Aid SSH, access the recess of the platform decking and pull the platform out from its safe position. (Fig. A9.12)
2. Move the platform into position at an angle from above in front of the last panel onto the cantilevered main beam.
3. Positive assembly is carried out by further lowering the platform:
  - The slide (45.1) on the underside of the platform is secured when positioned in the platform support (2.7) on the Main Beam SLT 375. (Fig. A9.12a)
  - The platform is locked in position and secured against tipping.
  - The anti-slip device locks into the teeth of the main beam.
  - The platform is secured against moving in the longitudinal direction of the beam.
4. Detach both crane hooks. Site personnel must wear personal protection equipment (PPE) to prevent falling!
  - Crane eye swivels downwards and the securing hook grips under the self-draining edges of the main beam. If necessary, press down the crane eye.
  - The platform is additionally secured against tipping and lifting. (Fig. A9.12b)
5. Install other platforms in the same way with the shuttering aid.
6. Close infill areas < 75 cm using contractor's own resources, e.g. scaffold planks 24 x 4.5 cm.

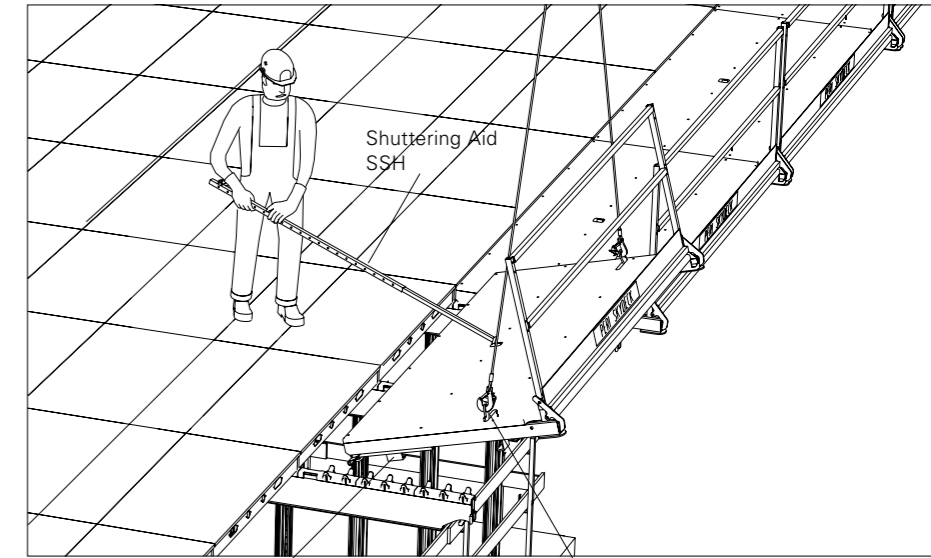

Fig. A9.12

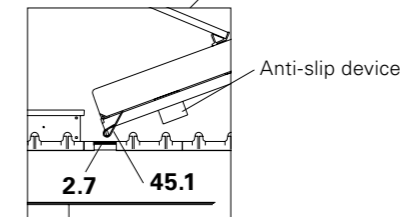

Fig. A9.12a

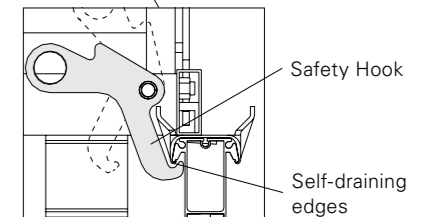

Fig. A9.12b

7. Handrails for infill areas are created using handrail boards 3 x 15 cm and toe boards (use nail holes in platform guardrails) or standard couplings and scaffold tubes.



For difficult assembly situations, e.g. wind, guide the platform with 2 shuttering aids. (Fig. A9.13)

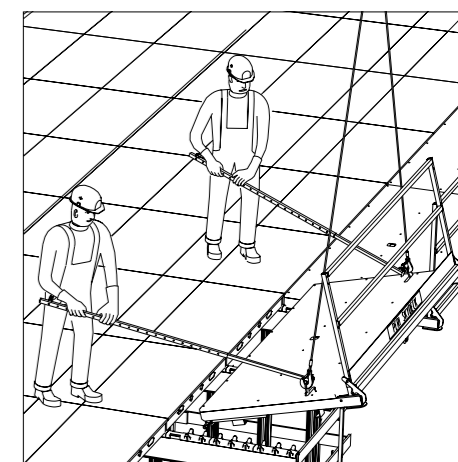

Fig. A9.13

## Striking



**Risk of falling!**  
When attaching the platforms to the crane lifting gear, site personnel must wear personal protection equipment (PPE) to prevent falling.

### Open edge areas

1. Strike the SKYDECK Slab Formwork in Area IV, see ground plan Fig. A9.01, in the direction of the slab edge up to the last but one bay of the cantilevered edge area.
2. Important: do not lower the props (1c, 35) of the cantilevered Main Beams SLT 375 (2.6), do not release the bracing!
3. Lower the dropheads or props (1a, 1b).
4. Strike the panels and main beams in the last but one standard bay (A). (Fig. A9.15). Do not strike bays B + C yet!
5. Mount end-to-end side protection on slabs that have been completed.
6. Attach 2-sling lifting gear to crane eyes of the platform decking. → The securing hook is released.
7. The platforms are now moved to the next place of use. (Fig. A9.14)
8. Loosen the tension chains in the edge area (bays B + C), lower the dropheads or props, remove panels and main beams.

### Corner table

1. If this has not already been done: mount end-to-end side protection on slabs that have been completed.
2. Raise the external and internal platforms.
3. Move the SKYDECK Transportation Fork under the timbers of the table.
4. Loosen the tension chains on the corner tables.
5. Retract the MULTIPROP Props MP. In areas with parapet walls, continue to retract or remove the props.
6. Lower the corner table.
7. Remove the infill area around the columns.
8. Move the table horizontally in the direction of Area III.

### Components

- |            |                      |
|------------|----------------------|
| <b>1</b>   | Drophead SFK         |
| <b>2.6</b> | Main Beam SLT 375    |
| <b>2.7</b> | Platform Support     |
| <b>23</b>  | Tension chain        |
| <b>24</b>  | Base Plate RS        |
| <b>35</b>  | MULTIPROP Prop MP    |
| <b>45</b>  | SKYDECK Platform SDK |

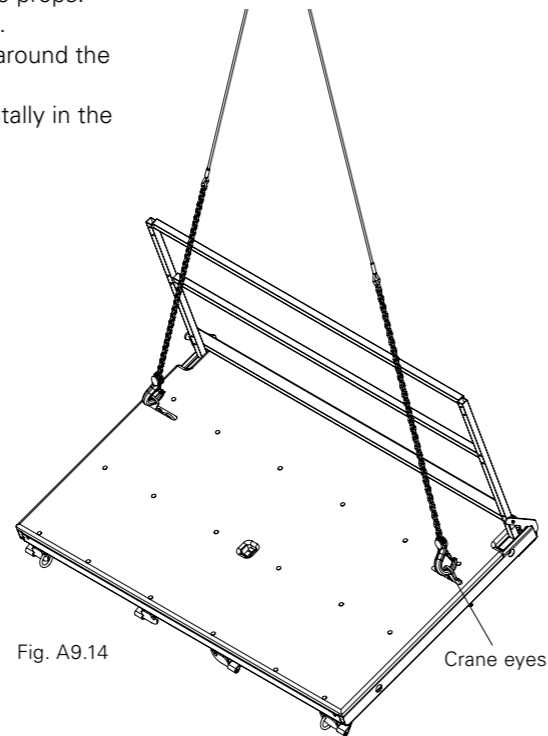

Fig. A9.14

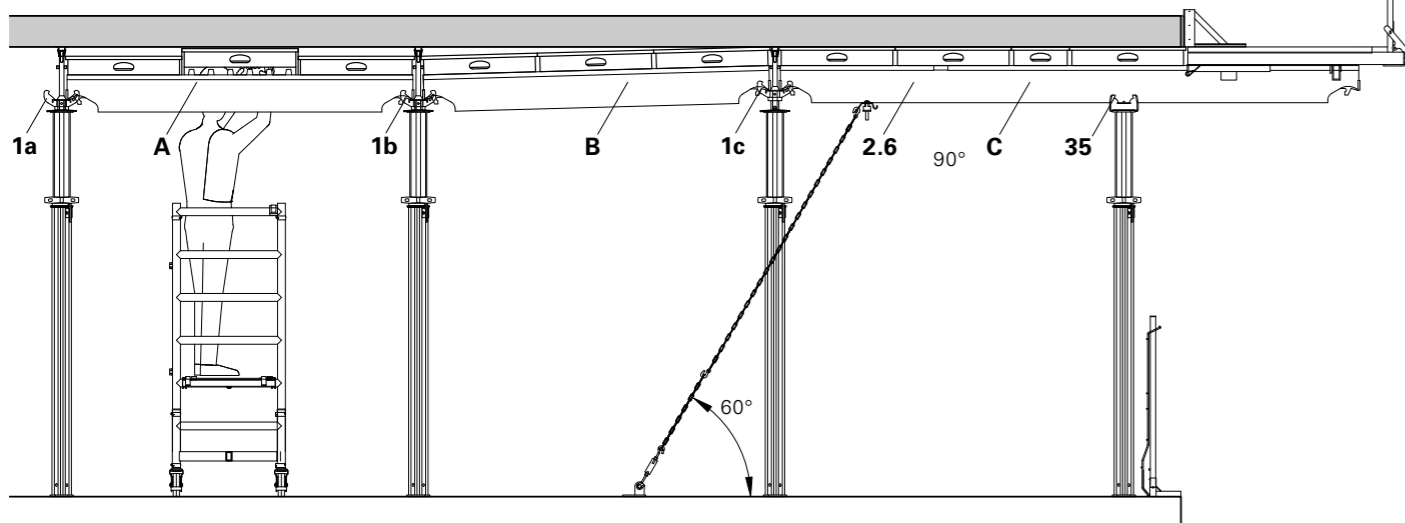

Fig. A9.15

## Working and safety scaffold

Use the SKYDECK Platform SDB 300 for longer slab sections. Also for corner tables, the Platform SDB 300 can be used instead of the Platform SDB 150. Use the Platform SDB 225 as a compensation platform.

The Platform SDB 225 has 4 slides on the underside. This means the platform can therefore cantilever to the right or the left by 75 cm if required. This is necessary to accommodate interruptions such as columns, offset walls or at an external wall. (Fig. A9.16)

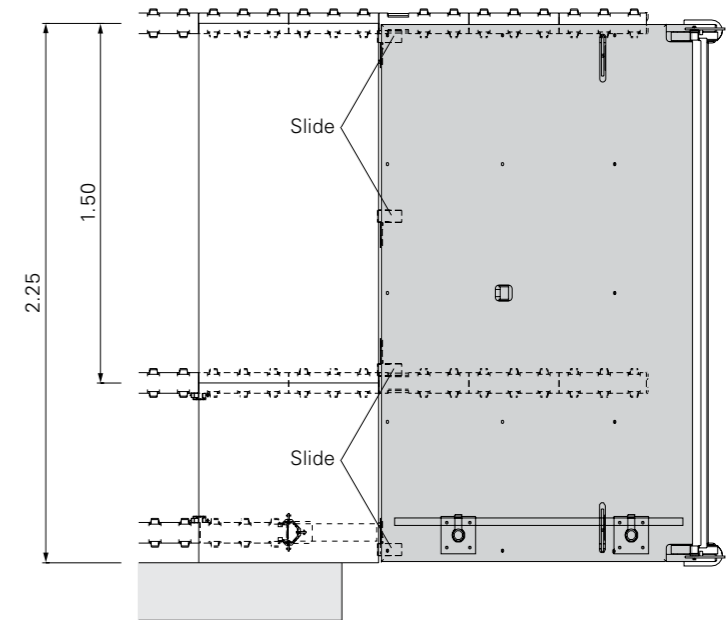

Fig. A9.16



Do not assemble push-pull props on the platform nor store materials! (Fig. A9.17a)  
Take into account the permissible load of 1.5 kN/m<sup>2</sup> (150kg/m<sup>2</sup>)!

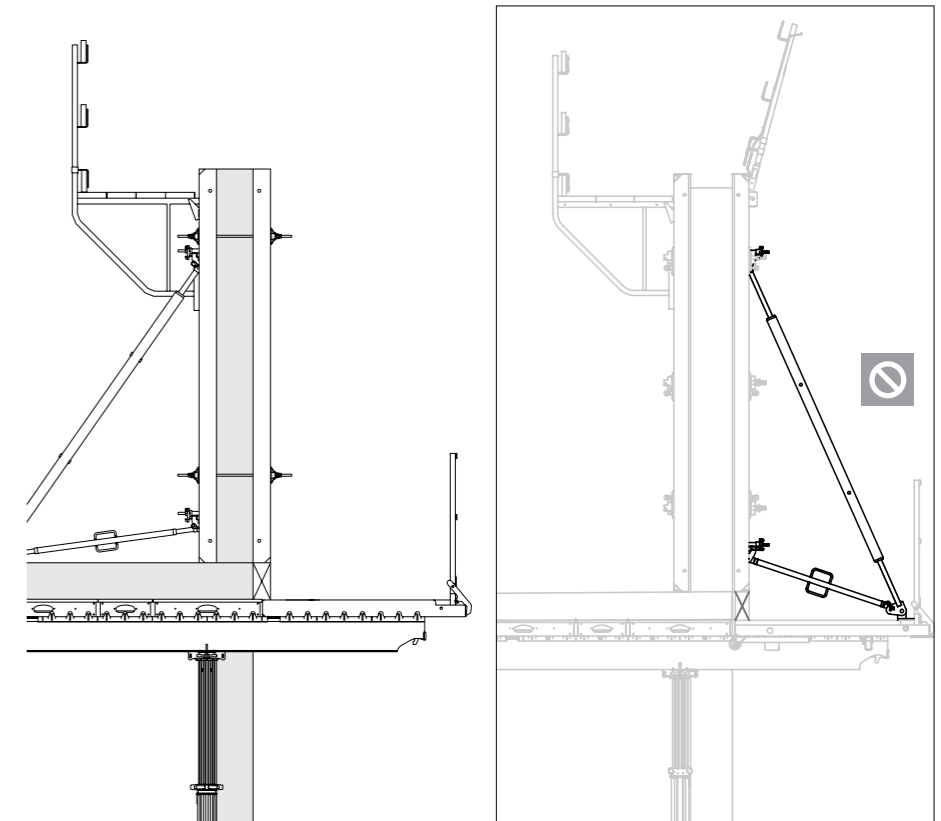

Fig. A9.17

Fig. A9.17a

## Platforms with SKYDECK Panels

Working from below:



**Shuttering is carried out using a safe mobile platform!**

1. Working from a secure, suitably guarded platform, install panels (3) on the Main Beam SLT 375 (2.6). (Fig. A9.18).
2. Secure panels to SLT Beam with 2 x Panel Clip SPK (21) per panel. (Fig. A9.19)

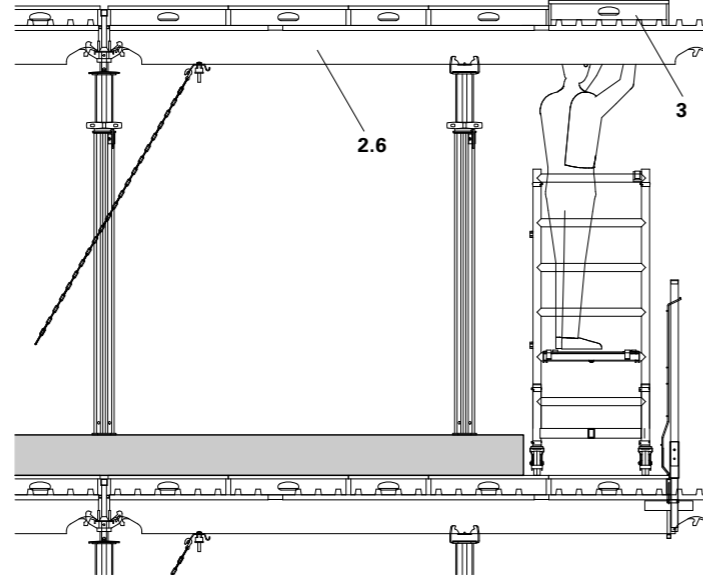

Fig. A9.18

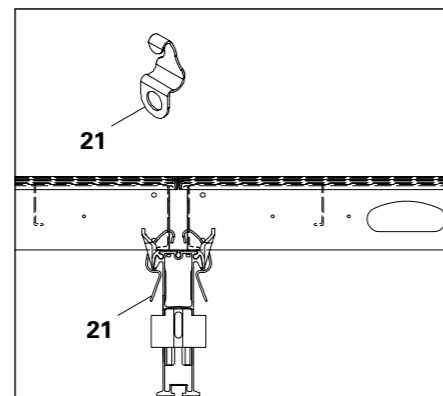

Fig. A9.19

### Components

- 2.6 Main Beam SLT 375
- 3 SKYDECK Panels
- 21 Panel Clip SPK
- 36 MULTIPROP Frame MRK

## SKYDECK Edge Protection



**Open edge area: Risk of falling!**  
When installing the edge protection, site personnel must wear personal protection equipment (PPE) with suitable, secure restraint to prevent risk of falling.

**Cantilevers should not be stepped on before being firmly secured with tension chains.**

### Assembly

Continuously mount Guardrail Holders SGH (17) between the Main Beams SLT 375 (2.6). (Fig. A9.20)

1. Ensure the internal platform area is suitably restrained against movement by connection to the permanent works (columns) or with use of temporary MULTIPROP Frames MRK (36).
2. Start with the guardrail holder on the outer right-hand side (17.1) as viewed when standing in front of the formwork. Mounting bar is pointing to the left.
3. Mount all other guardrails holders (17) with the mounting bar pointing to the right. The mounting bars overlap in the first bay. (Fig. A9.21)
4. Insert guardrail posts (18.N)
5. Insert guardrails or mesh edge protection (e.g. PROKIT Mesh Barriers) (Fig. A9.22)

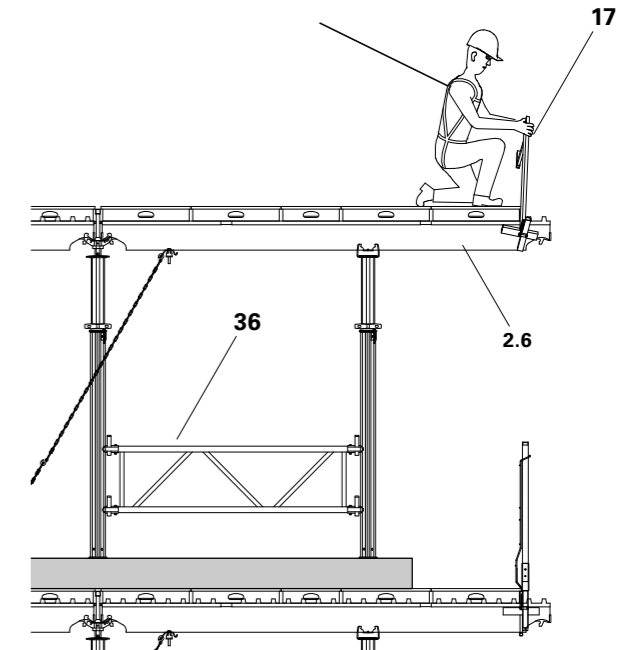

Fig. A9.20

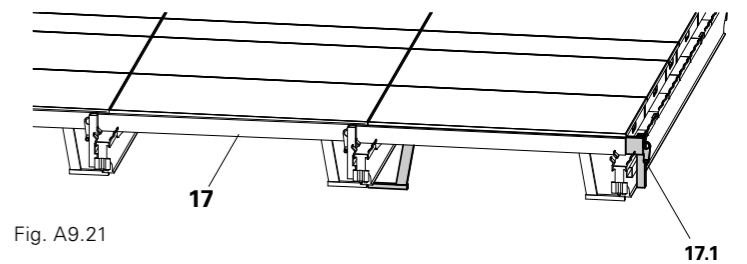

Fig. A9.21

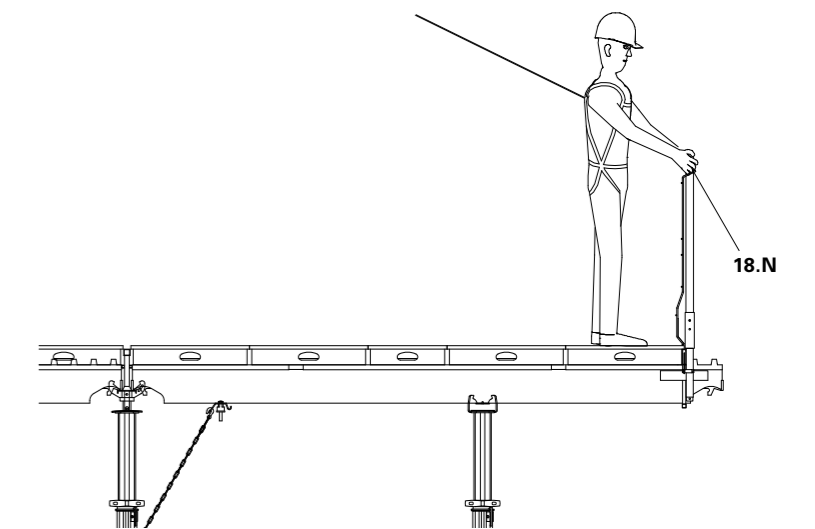

Fig. A9.22

### Components

- 2.6 Main Beam SLT 375
- 17 Guardrail Holder SGH
- 18.N Guardrail Post
- 36 MULTIPROP Frame MRK
- Edge Protection

## Striking

### Edge Protection



**Open edge areas: Risk of falling!**  
When dismantling the edge protection, site personnel must wear personal protection equipment (PPE) with suitable, secure restraint to prevent risk of falling.

1. Remove guardrails or mesh edge protection (e.g. PROKIT Mesh Barriers).
2. Remove guardrail posts (**18N**)
3. Remove guardrail holders (**17**). (Fig. A9.23)

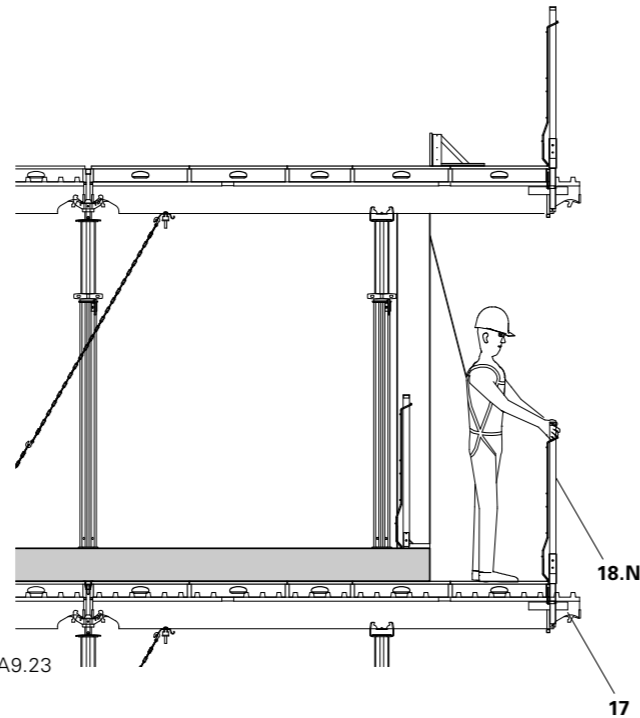

Fig. A9.23

### Panels and Beams

1. Attach the carabiner to the panel clip SPK at the outermost panel with the boat hook and hold / secure the attached rope. (Fig. A9.24)
2. Once the Panel Clip SPK is secured, remove it using the hook of the telescopic boat hook. (Fig. A9.24a).

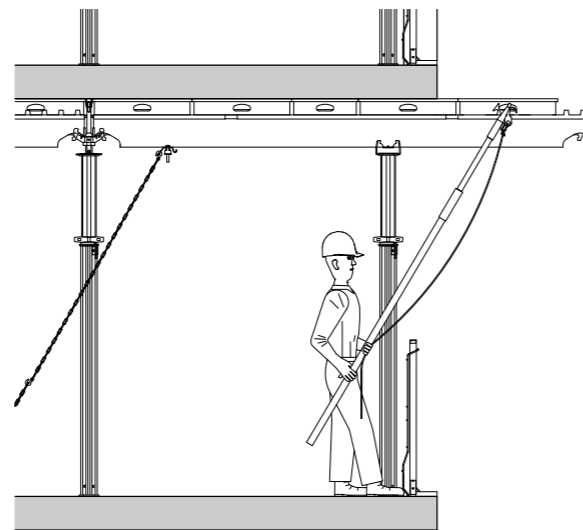

Fig. A9.24

### Components

- |             |                      |
|-------------|----------------------|
| <b>17</b>   | Guardrail Holder SGH |
| <b>18.N</b> | Guardrail Post       |
| --          | Edge Protection      |
| <b>21</b>   | Panel Clip SPK       |
| --          | Boat Hook            |

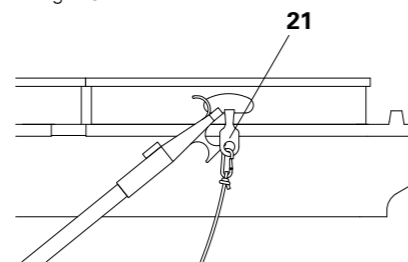

Fig. A9.24a



**Open edge areas: Risk of falling!**  
When removing the outer panels from above, site personnel must wear personal protection equipment (PPE) with suitable, secure restraint to prevent risk of falling.

1. Create a temporary gap in the cast slab edge protection and cordon off the area.
2. Working from the cast slab, remove the outer panels (**3**).
3. Reinstall the cast slab edge protection.

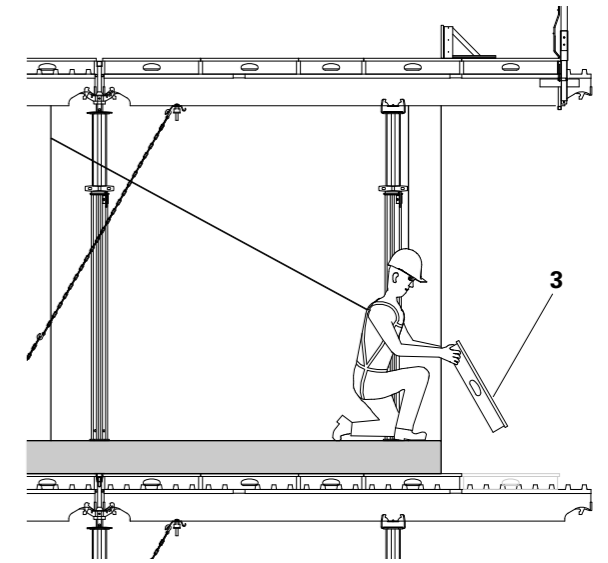

Fig. A9.25

**Dismantling is carried out from below using a safe mobile platform!**

1. Secure outer legs with universal tripod (N) or MRK Frames (Fig. A9.26)
2. Strike the dropheads or lower the props.
3. Remove panel clips SPK (**21**) and panels (**3**).
4. Remove the Main Beam SLT 375 (**2.6**) Tension Sleeve (**39**) and chain (**27**) assembly.

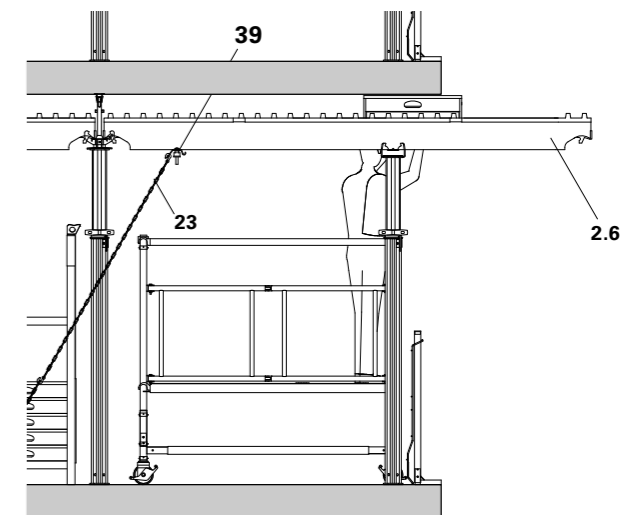

Fig. A9.26

### Components

- |            |                    |
|------------|--------------------|
| <b>2.6</b> | Main Beam SLT 375  |
| <b>3</b>   | SKYDECK Panel      |
| <b>21</b>  | Panel Clip SPK     |
| <b>23</b>  | Anchor Chain       |
| <b>39</b>  | Tension Sleeve SAO |

## System with Prophead SSK

If the Prophead SSK is used in the main bay, then the Transition Head SDFK (26) in connection with MULTIPROP Props is to be used when changing direction. Mount the Transition Head SDFK on the slab props using the two bolts and nuts (26.1) which are included in the delivery. During assembly of the prophead ensure that the collar of the nut (26.1) points towards the support of the MULTIPROP Props. Otherwise, overlapping may occur between nut and weld seam.

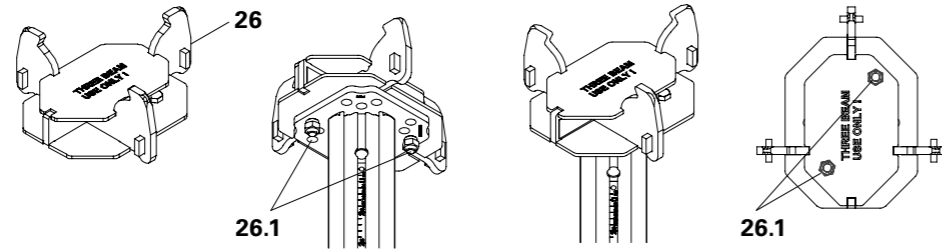

Fig. A10.01

## Changing the main bay direction by 90°

With the change in direction, the main bays are turned 90° without having to assemble a new system. As a result, T- and L-shaped ground plans are possible. The change of direction is realized using the Main Beams SLT 150 in the outer row of the main bay.

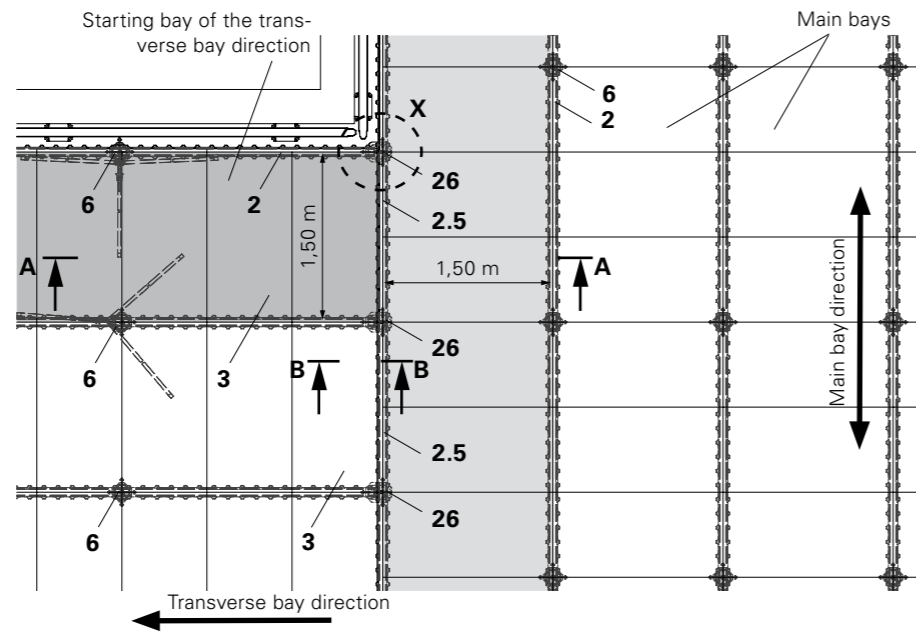

Fig. A10.02

### Section A-A

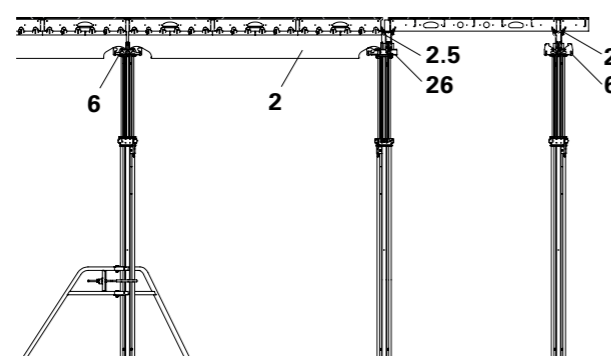

Fig. A10.02a



- The Transition Head SDFK must be mounted on the slab prop using the two bolts and nuts (26.1) which are included in the delivery.
- The Prophead SSK for changing direction must be used with 3 Main Beams SLT!

## Overview

(Fig. A10.02)

### Assembly of main bay direction

Assemble slab formwork in the direction of the main bay with slab props, Prophead SSK (6), Main Beam SLT 225 (2) and Panels SDP (3): see Section A4 Shuttering.

## Changing direction

- Main bay direction
  1. Install slab prop with Prophead SSK (26) with a spacing of 1.50 m and secure with tripods.
  2. Mount Main Beam SLT 150 (2.5) instead of SLT 225. (Fig. A10.02 + A10.02a)
- Transverse bay direction
  3. Continue assembling in the direction of the transverse bay with slab prop, Prophead SSK (6) and Main Beams SLT: see Section A4 Shuttering. (Fig. A10.02 + A10.03) Secure slab props with tripods.
  4. Install Panels SDP 150 x 75 (3) in the direction of the transverse bay. (Fig. A10.02)
  5. If a gap occurs with the Panel SDP between the transverse bay direction and main bay direction, this is closed using filler timber (12) and filler plate (16). (Fig. A10.04)

## Detail X

without filler timber

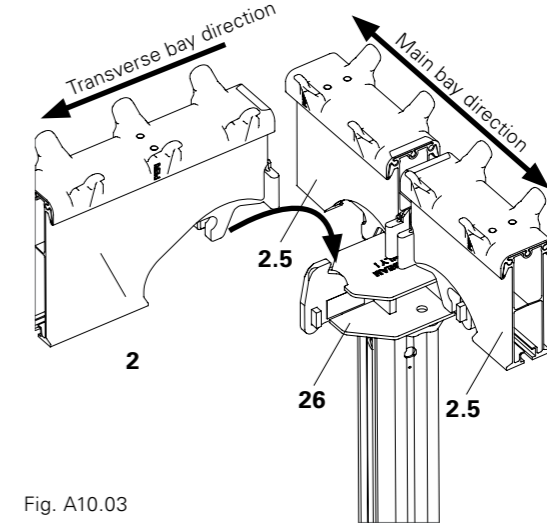

Fig. A10.03

## Section B-B

with filler timber

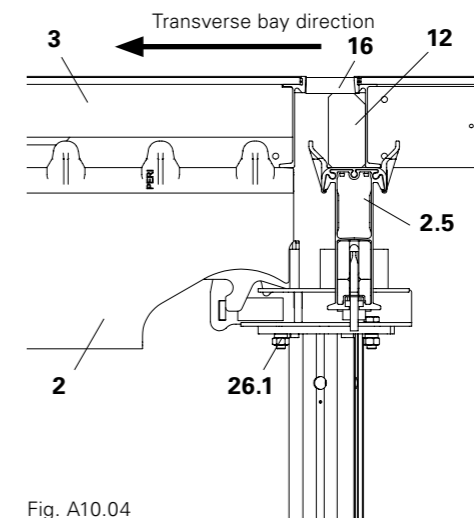

Fig. A10.04

## Required components per change of direction bays.

26	Prophead SSK*	1x
26.1	Bolt M12 with MP Nut	2x
6	Prophead SSK	1x
2.5	Main Beam SLT 150	1x
2	Main Beam SLT 225**	1x
3	Panel SDP**	x
12	Filler Timber SPH	1x
16	Filler Plate	1x

\* Transition Head SDFK

\*\* depending on size of bay or plan

# A10 Changing direction



## System with Drophead SFK

If the Drophead SFK is used in the main bay, then the Transition Head SDFK (27) is to be used when changing direction. It consists of a Drophead (27.1) and Connector (27.2).

### Changing the main bay direction by 90°

With the change in direction, the main bays are turned 90° without having to assemble a new system. As a result, T- and L-shaped ground plans are possible.



The change of direction is realized using Main Beams SLT, additional slab props with Transition Head SDFK in the outer row of the main bay as well as Frame MRK.

### Required components per change of direction bays.

1	Drophead SFK	1x
2	Main Beam SLT 225	1x
2a	Main Beam SLT 150 / 225	1x
3	Panel SDP 150 x 75	1x
3.1	Panel SDP 150 x 37.5 / 50	1x
9	Edge Beam SRT 150-2	1x
11	End Support SSL	1x
12	Filler Timber SPH	1x
16	Filler Plate	1x
27.1	Drophead SDFK*	1x
27.2	Connector SDFK*	1x
30	Tripod	1x

\* Transition Head SDFK

### Overview

(Fig. A10.06 + A10.06a)

### Assembly of main bay direction

Assemble slab formwork in the direction of the main bay with slab props, Drophead SFK (1), Main Beam SLT 225 (2) and Panels SDP (3): see Section A4 Shuttering.

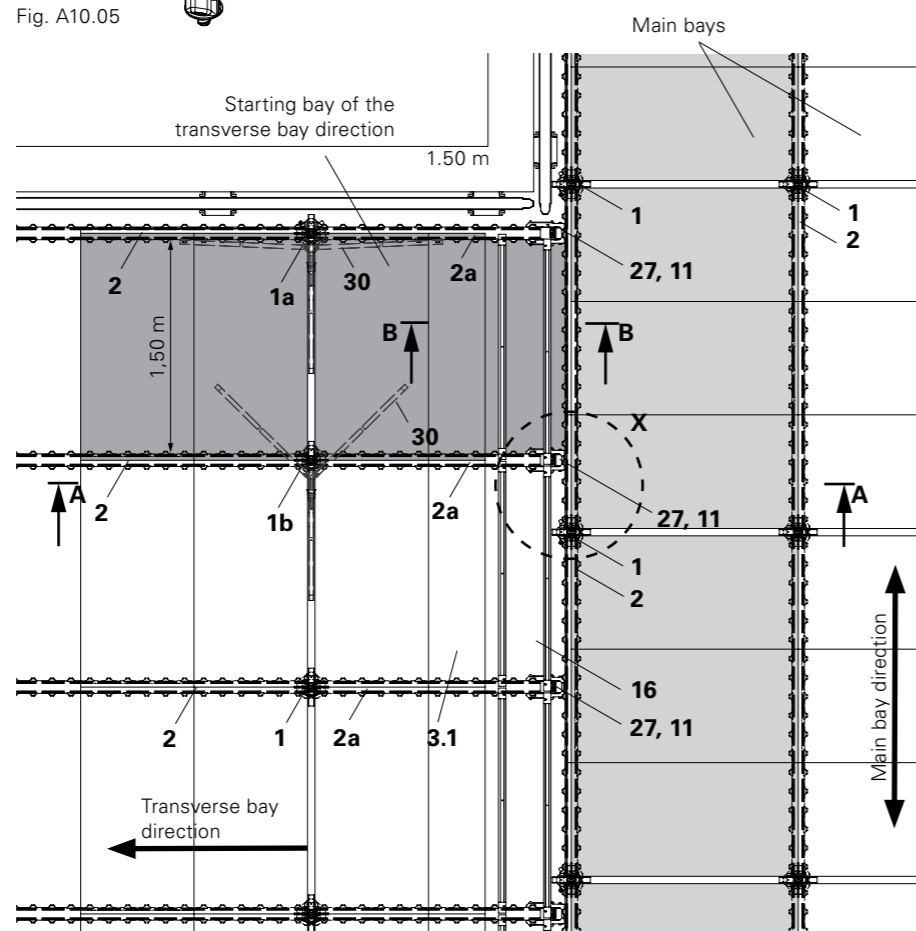
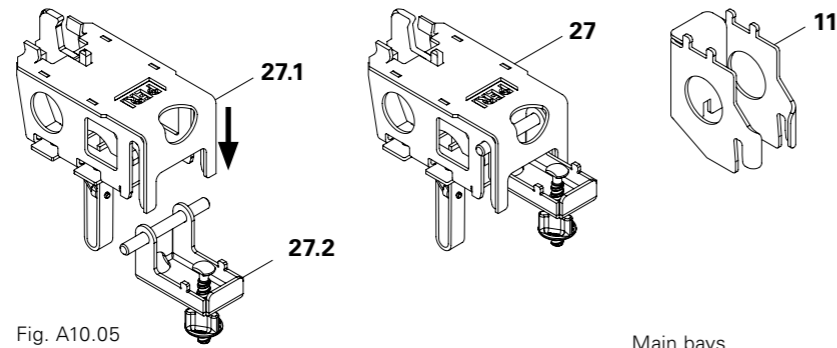

Fig. A10.06

### Section A-A

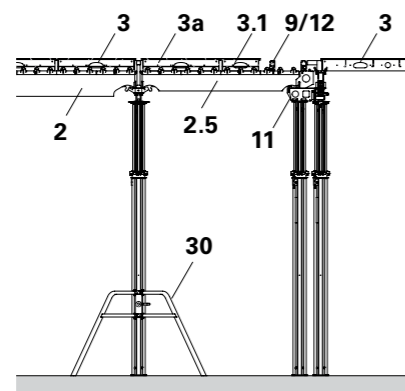

Fig. A10.06a

# A10 Changing direction



## Changing direction

### Main bay direction

1. Insert the Connector (27.1) with the groove bolt into the Main Beam SLT 225 (main bay) and tighten by hand. (Fig. A10.07)
2. Mount the Transition Head Upper Part SDFK (27.2) individually or with the slab prop in the connector. (Fig. A10.07a)
3. Mount the second Drophead SDFK at a distance of 1.50 m. (Fig. A10.06)

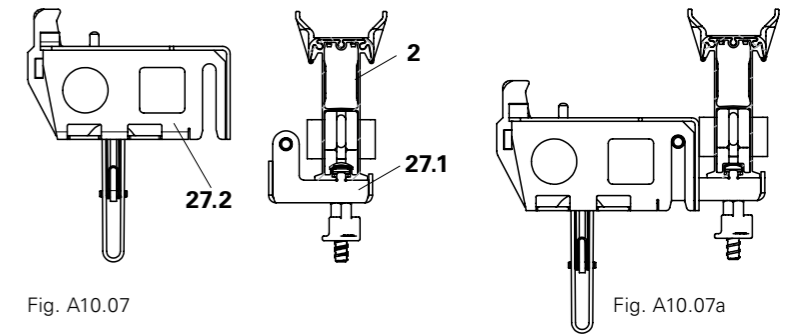
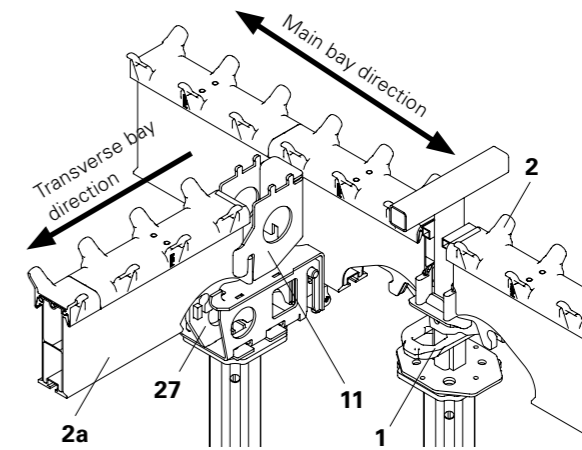

Fig. A10.07

Fig. A10.07a

### First transverse bay 1.50 m x 1.50 m

4. Position one slab prop with Drophead SFK (1a) in the direction of the transverse bay. (Fig. A10.06)
5. Position second slab prop with Drophead SFK (1b) and secure slab props with tripods (30). (Fig. A10.06)
6. Mount Main Beam SLT 150 / 225 (2a) in the Dropheads. (Fig. A10.06, A10.08, A10.08a)



Detail X without filler timber

Fig. A10.08

### Additional transverse bays

Assemble additional transverse bays in the same way as the first transverse bay along the Main Beam SLT 225. (Fig. A10.06) – Spacing (bay width) 1.50 m, – without Frame MRK, see Section A4 Shuttering.

### Install Panels SDP:

Insert panels in the direction of the main bay.

1. Insert Panel SDP 150 x 75 (3a).
2. Insert Filler Panel SDP 150 x 37.5 (3.1).
3. Fix End Support SSL (11) to the Main Beam SLT in the infill area. Install Edge Beam SRT 150-2 (9) as well as Filler Timber SPH 225 (12) and filler plates (16), see Section A5 Compensations. (Fig. A10.06, A10.06a, A10.08a)

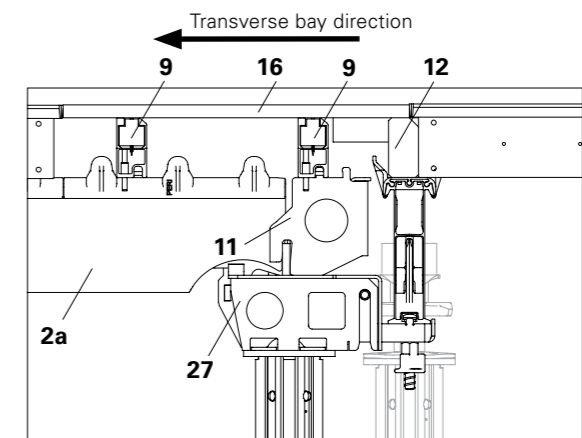

Section B-B with filler timber

Fig. A10.08a

### Continue assembling the transverse bays

Assemble transverse bay with slab props, Drophead SFK (1), Main Beam SLT 225 (2) and Panels SDP (3), see Section A4 Shuttering.



If a Drophead SDFK encounters the position of a Drophead SFK in the direction of the main bay, a 75 cm intermediate bay is to be installed. After this, installation continues with spacings of 1.50 m. (Fig. A10.09)

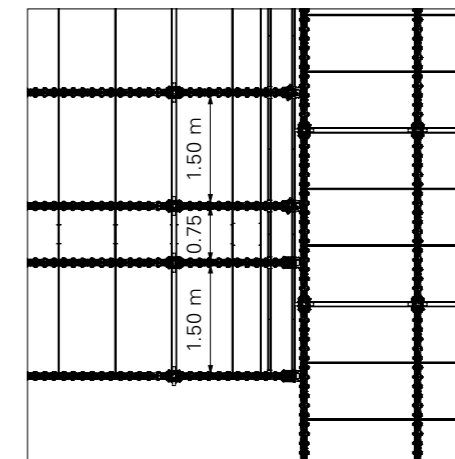

Fig. A10.09

# A11 Inclined slabs



The Main Beam SLT must be positioned in the direction of the slab inclination. Align Props with Drophead SFK at right-angles to the Main Beams SLT 225. The use with Prophead SSK is also possible. (Fig. A11.01)



When using PEP Slab Props, the Drop-head SFK is diagonally bolted by means of 2 Bolts M12 x 35-8.8 and Nut M12. Tension forces and prop loads: see Table A15.01.

## Bracing with Tension Sleeve SAO and Chain 3.0 kN

### Assembly

1. Set up first bay with tripods or Frame MRK.
2. Mount Base Plate (24) on a sufficiently load-bearing surface area, e.g. using PERI Anchor Bolt 14/20x130, item no. 124777. Take into consideration the Technical Data Sheet!
3. Screw on Tension Sleeve SAO (39) to Main Beam SLT.
4. Attach Anchor Chain (23) to Tension Sleeve SAO (39).
5. Secure Anchor Chain to Base Plate using bolts, and secure bolts by means of cotter pins.
6. Pretension Anchor Chain. (Fig. A11.01)

### Components

- |             |   |
|-------------|---|
| <b>23</b>   | Anchor Chain (permissible tension force = 3 kN) |
| <b>24</b>   | Base Plate RS                                   |
| <b>24.1</b> | Anchor Bolt PERI 14/20 x 130                    |
| <b>39</b>   | Tension Sleeve SAO                              |

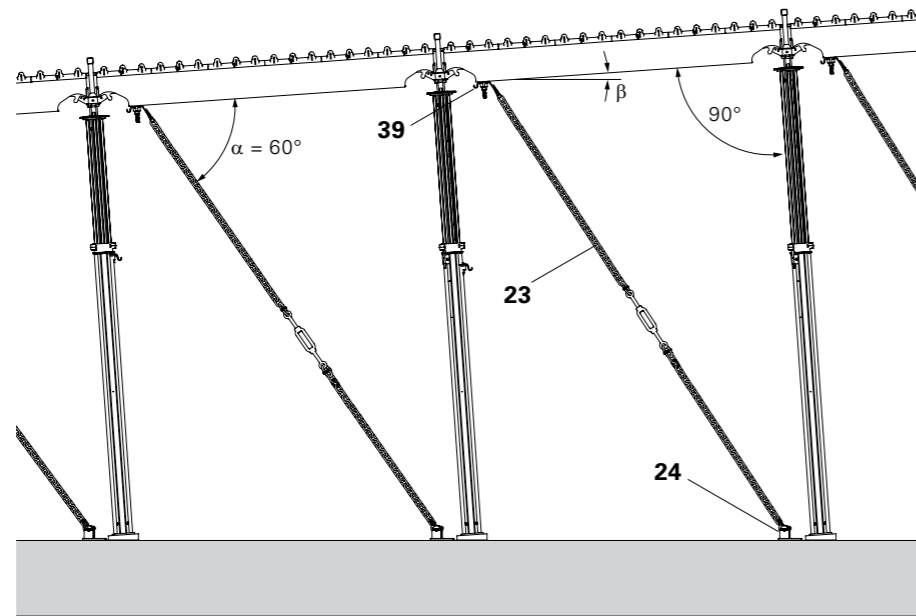

Fig. A11.01

# A11 Inclined slabs



## Bracing with Tension Unit SD



Selection of bracing angle  $\alpha$ : see Table A15.02. Tension forces and prop loads: see Tables A15.03 - A15.04. Bracing angle with Drophead SFK max. 60°. Bracing angle with Prophead SSK max. 50°.

### Assembly

1. Position slab prop with tripod.
2. Place the Tension Unit Upper Part (41.1) on the end plates of the Main Beam SLT (2.8) and attach the Main Beam to the Drophead SFK. (Fig. A11.03)
3. Swivel up the Main Beam with the second slab prop. Tension Unit must lie on the end plates of the Main Beam SLT.
4. Mount Base Plate-2 (29) on a sufficiently load-bearing surface area, e.g. using PERI Anchor Bolt 14/20x130, Item no. 124777. Take into consideration the Technical Data Sheet!
5. Insert the Tie Yoke of the Tension Unit Upper Part onto the Tie Rod (41.3), secure with the Hex. Nut SW 30/50 (42), and attach to the Tension Unit Upper Part. (Fig. A11.03 + A11.04)
6. Fix Tension Unit Lower Part (41.2) to the Base Plate by means of bolts, and secure bolts using cotter pins. (Fig. A11.02)
7. Insert Tie Yoke of the Tension Unit Lower Part onto the Tie Rod, secure with Triple Wingnut DW 15 (43), and attach to the Tension Unit Lower Part. (Fig. A11.05 + A11.06)
8. Tension the Tension Unit using a Triple Wingnut.

### Components

- |             |                              |
|-------------|------------------------------|
| <b>29</b>   | Base Plate-2 RS              |
| <b>24.1</b> | Anchor Bolt PERI 14/20 x 130 |
| <b>41</b>   | Tension Unit SD              |

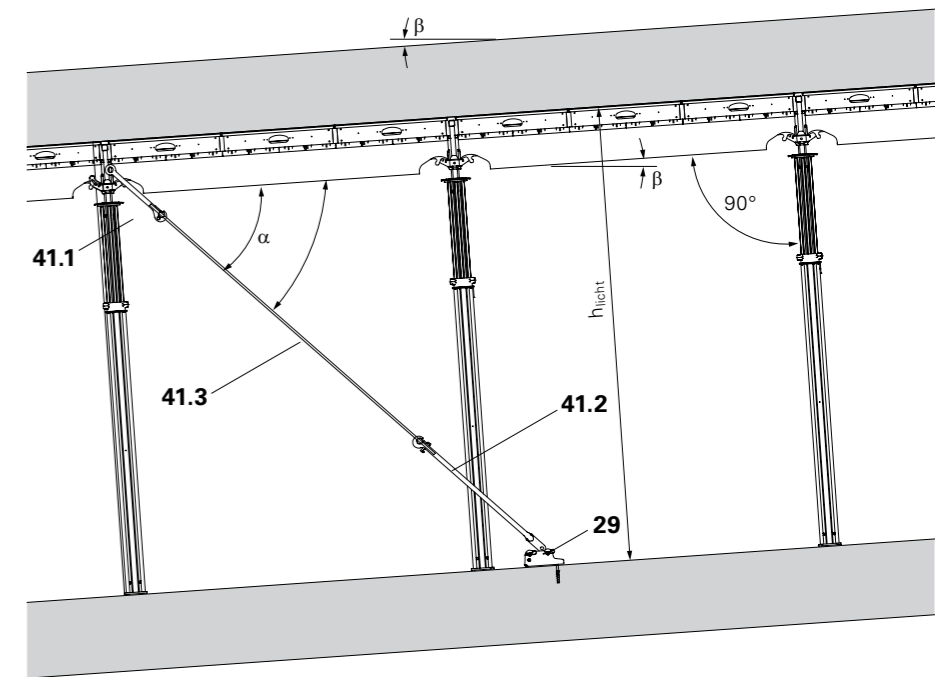

Fig. A11.02

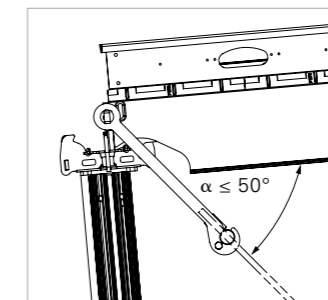

Fig. A11.02a

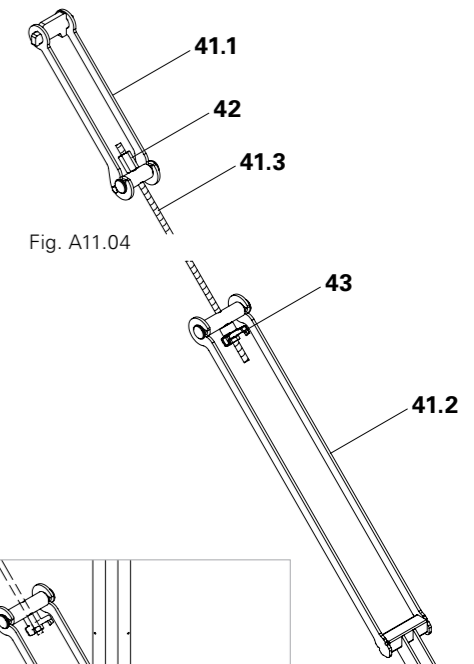

Fig. A11.04

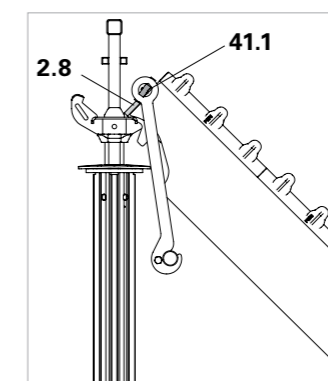

Fig. A11.03

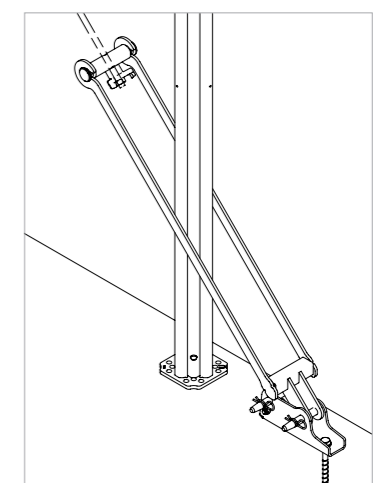

Fig. A11.05

Fig. A11.06



**Striking times: see Tables!**  
**Keep access ways free!**

Dismantling takes place from a safe and secure position, e.g. with PERI Stripping Cart ASW 465.

### Lowering

- Lower dropheads over large area. Release wedges with hammer. Pay attention to direction of wedge!  
 → Between the panel and slab underside there is a clearance of approx. 6 cm. (Fig. A12.01)

### Edge infills

Striking of the transverse infills takes place first and then of the longitudinal infills.

- Remove props and store in pallets.
- Dismantle system supplements such as filler timbers, edge beams, end supports and combiheads, and store in pallets. (Fig. A12.02)
- Remove filler plates.



- **Striking is carried out by means of a safe mobile scaffold!**
- **Unsupported slab props can overturn. Secure by means of tripods.**

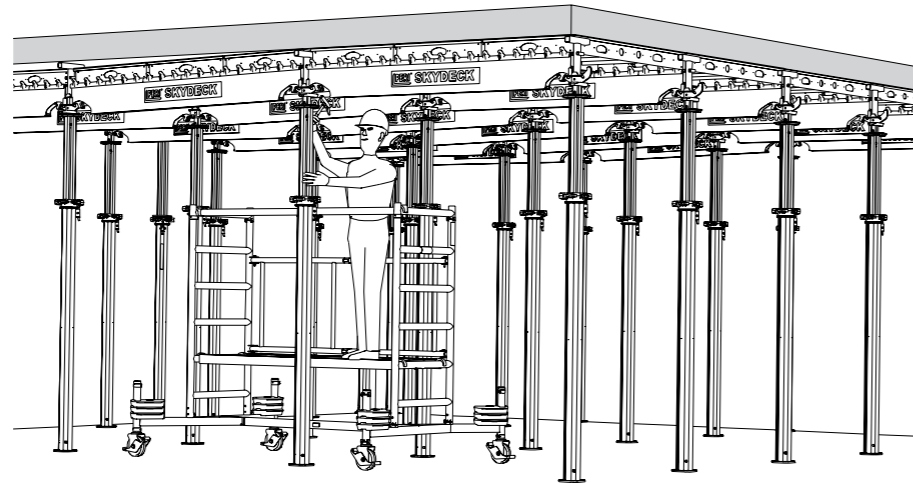

Fig. A12.01

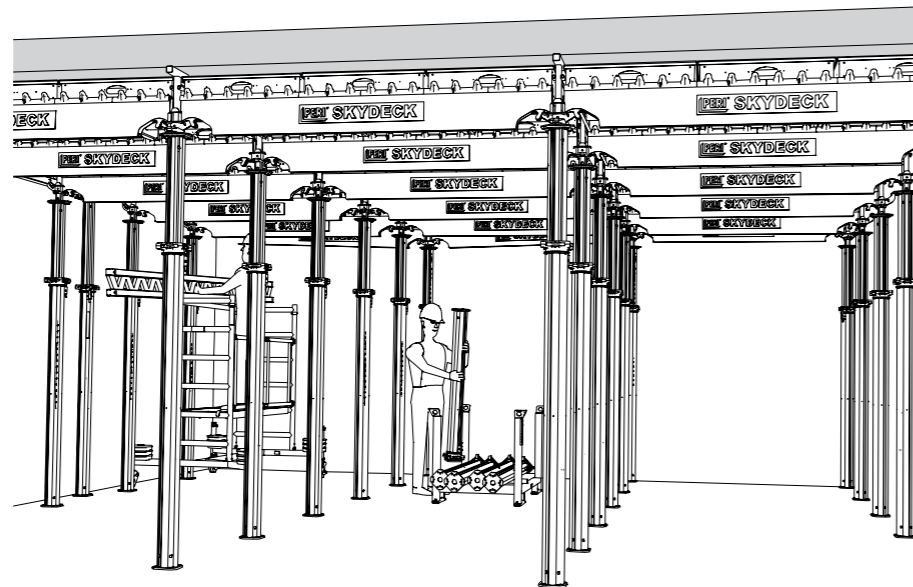

Fig. A12.02

### Panels

Always begin in the corner where both infills meet.

- Dismantle Panels SDP in one bay after the other - begin with the middle panel.
- Lift panel and push aside approx. 10 cm in the direction of the compensation area. Pivot downwards and store in pallets.

(Fig. A12.03)

### Main Beam

- Pivot Main Beam SLT slowly downwards, remove and store in pallets.

(Fig. A12.04)

Only Drophead Props (1) with Cover Strips SAL (4) remain standing. (Fig. A12.05)

### Remaining areas

- Remove props on walls and store in pallets.
- Remove infill areas around columns.

### After reaching the required concrete strength

- lower Drophead Props, remove props and store in pallets.
- remove Cover Strips SAL (4).



With larger spans, begin in the middle with lowering and removal of the props.

### Cleaning

Clean SKYDECK components before the next use and spray once again, e.g. with PERI Bio Clean. See introduction "Cleaning and maintenance".

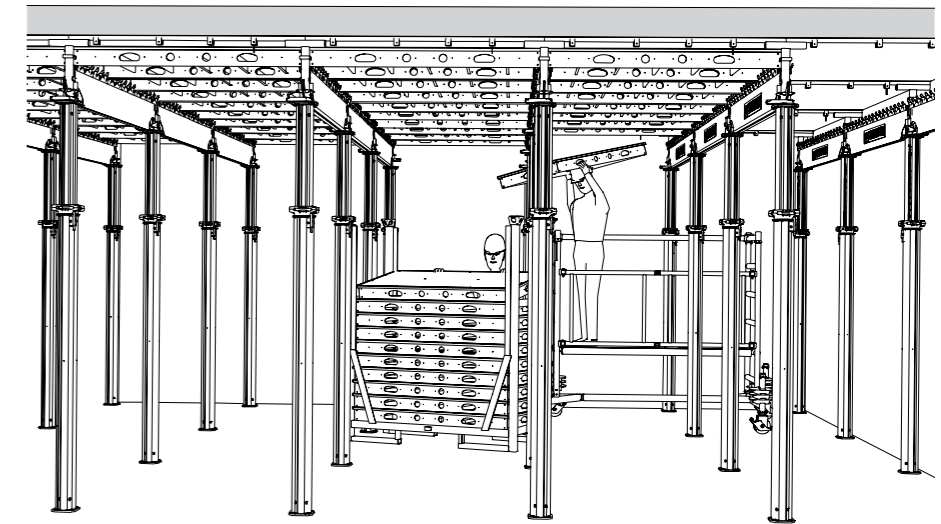

Fig. A12.03

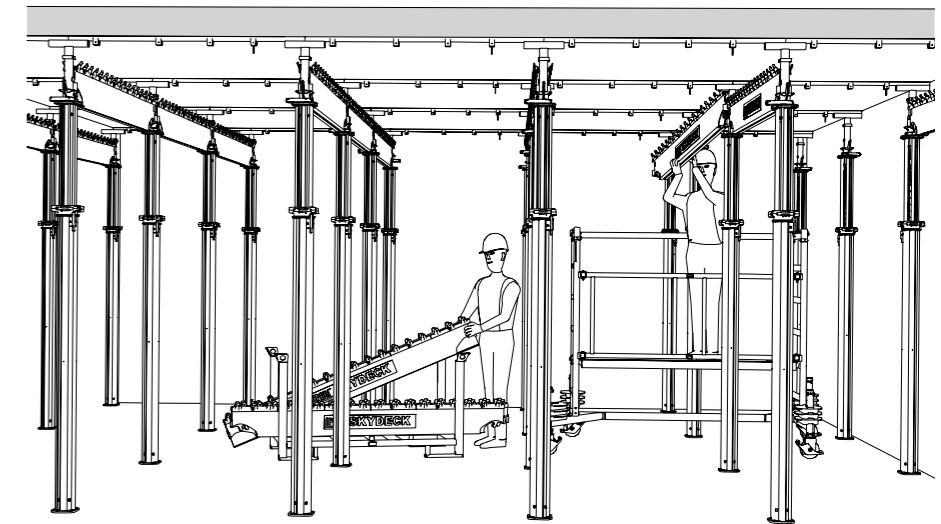

Fig. A12.04

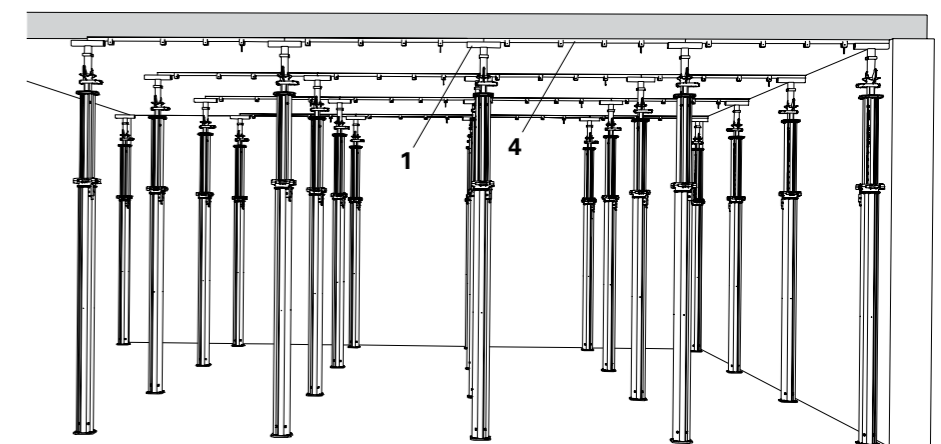

Fig. A12.05

Company: .....  
 Project: .....  
 Component: .....

This page is to be copied, filled out and filed in the daily construction records.

Execution / Installation of the formwork	Slab thickness = ..... cm
	Clear room height = ..... m
	Prop length = ..... m = clear room height - formwork assembly height (with Drophead: 41 cm)
	Max. panel span = ..... cm
	Selected prop = .....
	Actual prop load = ..... kN (according to PERI Tables)
	Direction of assembly Inner tube bottom..... <input type="checkbox"/> Outer tube bottom..... <input type="checkbox"/>
≤ perm. prop load = ..... kN (according to PERI Tables)	
Check to be carried out on the construction site before concreting	<b>Check whether above assumptions and/or specifications apply on the construction site</b>
	Slab thickness = ..... cm
	Max. panel span = ..... cm
	Selected prop = ..... m
	Selected prop length = ..... m
	Direction of assembly Inner tube bottom..... <input type="checkbox"/> Outer tube bottom..... <input type="checkbox"/>
	Are all props in both axes in a vertical position? ≤ 1% ..... <input type="checkbox"/> yes <input type="checkbox"/>
	Horizontal support for the formwork available in all directions? ..... <input type="checkbox"/> yes <input type="checkbox"/>
	Mounted parts are obviously undamaged? ..... <input type="checkbox"/> yes <input type="checkbox"/>
	Required bracing has been mounted? ..... <input type="checkbox"/> yes <input type="checkbox"/>

### System with Drophead SFK or Prop-head SSK and Main Beam SLT 225



- Horizontal loads per edge area are determined for an open building edge on one side!
- Increase prop loads in the braced areas by  $\Delta V = 2.60$  kN!

Slab Thickness (m)	Applied Load, q (kN/m <sup>2</sup> )	Horizontal Load edge area (kN)		Load case combination 1: Concreting*				Load case combination 2: Maximum wind**				LCC 1: Concreting*	
		from concrete pressure		Horizontal Load inner bay (kN)		Horizontal Load edge area (kN)		Horizontal Load inner bay (kN)		Horizontal Load edge area (kN)		2.5% of Vertical Load	
		c = 1.50m	c = 0.75m	c = 1.50 m	c = 0.75 m	c = 1.50 m	c = 0.75 m	c = 1.50 m	c = 0.75 m	c = 1.50 m	c = 0.75 m	c = 1.50 m	c = 0.75 m
0.150	5.38	0.42	0.21	0.19	0.09	0.98	0.49	0.007	0.004	1.13	0.57	0.46	0.23
0.175	5.99	0.57	0.29	0.21	0.10	1.17	0.58	0.007	0.004	1.17	0.59	0.52	0.26
0.200	6.60	0.75	0.38	0.23	0.11	1.38	0.69	0.007	0.004	1.21	0.61	0.57	0.28
0.225	7.21	0.95	0.47	0.25	0.12	1.61	0.81	0.007	0.004	1.25	0.63	0.62	0.31
0.250	7.83	1.17	0.59	0.27	0.13	1.87	0.94	0.007	0.004	1.29	0.65	0.67	0.34
0.275	8.44	1.42	0.71	0.29	0.15	2.15	1.08	0.007	0.004	1.33	0.67	0.73	0.36
0.300	9.04	1.69	0.84	0.31	0.16	2.45	1.23	0.007	0.004	1.37	0.69	0.78	0.39
0.325	9.71	1.98	0.99	0.33	0.17	2.78	1.39	0.007	0.004	1.41	0.71	0.84	0.42
0.350	10.38	2.30	1.15	0.36	0.18	3.14	1.57	0.007	0.004	1.45	0.73	0.90	0.45
0.375	11.06	2.64	1.32	0.38	0.19	3.51	1.76	0.007	0.004	1.49	0.75	0.95	0.48
0.400	11.73	3.00	1.50	0.40	0.20	3.91	1.96	0.007	0.004	1.53	0.77	1.01	0.51
0.425	12.40	3.39	1.69	0.43	0.21	4.34	2.17	0.007	0.004	1.57	0.79	1.07	0.53
0.450	13.08		1.90		0.23		2.39		0.004		0.80		0.56
0.475	13.75		2.12		0.24		2.63		0.004		0.82		0.59
0.500	14.43		2.34		0.25		2.87		0.004		0.85		0.62
0.525	15.10		2.58		0.26		3.13		0.004		0.87		0.65
0.550	15.77		2.84		0.27		3.40		0.004		0.89		0.68
0.575	16.45		3.10		0.28		3.69		0.004		0.91		0.71
0.600	17.12		3.38		0.30		3.98		0.004		0.93		0.74
0.625	17.79		3.66		0.31		4.28		0.004		0.95		0.77
0.650	18.47		3.96		0.32		4.60		0.004		0.97		0.80
0.675	19.14		4.27		0.33		4.93		0.004		0.99		0.83
0.700	19.82		4.59		0.34		5.27		0.004		1.01		0.85
0.725	20.46		4.93		0.35		5.62		0.004		1.03		0.88
0.750	21.08		5.27		0.36		5.99		0.004		1.05		0.91
0.775	21.69		5.63		0.37		6.36		0.004		1.07		0.94
0.800	22.30		6.00		0.38		6.75		0.004		1.09		0.96
0.825	22.91		6.38		0.40		7.15		0.004		1.11		0.99
0.850	23.53		6.77		0.41		7.56		0.004		1.13		1.01
0.875	24.14		7.18		0.42		7.98		0.004		1.15		1.04
0.900	24.75		7.59		0.43		8.41		0.004		1.17		

Table A14.01

\* Load case combination 1: erection tolerance + edge formwork concrete pressure + working wind pressure

\*\* Load case combination 2: erection tolerance + maximum wind pressure  
 Maximum wind pressure assumed at 0.6 kN/m<sup>2</sup>

Place \_\_\_\_\_ Date \_\_\_\_\_ Site manager in charge (Signature) \_\_\_\_\_

# A15 Inclined slabs



## System with Drophead SFK

### Maximum permissible slab inclination with Tension Sleeve SAO and Chain 3.0 kN

#### Considered horizontal loads

Horizontal load from erection tolerance and imperfections = 1% of the vertical load (BS 5975-2:2024: 7.2.2.3)

Horizontal load from legs erected out of vertical by design = Vertical load x Sin β ((BS 5975-2:2024:7.2.3)

Angle α between Chain and SLT 225 = 60°

Max. tension force of Tension Sleeve SAO and Anchor Chain = 3.0 kN

#### SKYDECK Tension Unit SD - bracing angle α selection

Angle α Tension Unit SD	possible clear room height with SSK and SLT 225		possible clear room height with SFK and SLT 225	
	min h <sub>minimum clearance</sub>	max h <sub>minimum clearance</sub>	min h <sub>minimum clearance</sub>	max h <sub>minimum clearance</sub>
30 °	1.72 m	2.01 m	1.73 m	2.02 m
35 °	2.02 m	2.34 m	2.04 m	2.36 m
40 °	2.37 m	2.71 m	2.39 m	2.73 m
45 °	2.77 m	3.12 m	2.80 m	3.15 m
50 °	3.25 m	3.60 m	3.28 m	3.63 m
55 °	3.84 m	4.16 m	3.88 m	4.20 m
60 °	4.60 m	4.87 m	4.65 m	4.91 m

Table A15.01

Drophead SFK		Panel Span = 1.5 m				
Slab thickness (m)	Applied Load, q (kN/m <sup>2</sup> )	Drophead Load (kN)	Braced Drophead Load (kN)	1 Bay Angle β (°)	2 Connected Bays Angle β (°)	3 Connected Bays Angle β (°)
0.150	5.38	18.54	21.14	4.07	1.74	0.97
0.175	5.99	20.66	23.26	3.59	1.51	
0.200	6.60	22.77	25.37	3.20	1.31	
0.225	7.21	24.88	27.48	2.88	1.15	
0.250	7.83	27.00	29.60	2.61	1.02	
0.275	8.44	29.11	31.71	2.38	0.90	
0.300	9.04	31.17	33.77	2.18		
0.325	9.71	33.50	36.10	1.99		
0.350	10.38	35.82	38.42	1.83		
0.375	11.06	38.14	40.74	1.68		
0.400	11.73	40.47	43.07	1.55		
0.425	12.40					
0.450	13.08					
0.475	13.75					
0.500	14.43					
0.525	15.10					
0.550	15.77					
0.575	16.45					
0.600	17.12					
0.625	17.79					
0.650	18.47					
0.675	19.14					
0.700	19.82					
0.725	20.46					
0.750	21.08					
0.775	21.69					
0.800	22.30					
0.825	22.91					
0.850	23.53					

Table A15.02

# A15 Inclined slabs



## System with Drophead SFK

### Maximum permissible slab inclination with Tension Sleeve SAO and Chain 3.0 kN

Drophead SFK		Panel Span = 0.75 m						
Slab thickness (m)	Applied Load, q (kN/m <sup>2</sup> )	Drophead Load (kN)	Braced Drophead Load (kN)	1 Bay Angle β (°)	2 Connected Bays Angle β (°)	3 Connected Bays Angle β (°)	4 Connected Bays Angle β (°)	5 Connected Bays Angle β (°)
0.150	5.38	9.27	11.87	8.73	4.07	2.52	1.74	1.28
0.175	5.99	10.33	12.93	7.77	3.59	2.20	1.51	1.09
0.200	6.60	11.39	13.99	6.99	3.20	1.94	1.31	0.94
0.225	7.21	12.44	15.04	6.35	2.88	1.73	1.15	
0.250	7.83	13.50	16.10	5.80	2.61	1.55	1.02	
0.275	8.44	14.55	17.15	5.34	2.38	1.40	0.90	
0.300	9.04	15.59	18.19	4.95	2.18	1.27		
0.325	9.71	16.75	19.35	4.56	1.99	1.14		
0.350	10.38	17.91	20.51	4.23	1.83	1.03		
0.375	11.06	19.07	21.67	3.94	1.68	0.93		
0.400	11.73	20.23	22.83	3.68	1.55			
0.425	12.40	21.40	24.00	3.45	1.44			
0.450	13.08	22.56	25.16	3.24	1.33			
0.475	13.75	23.72	26.32	3.05	1.24			
0.500	14.43	24.88	27.48	2.88	1.15			
0.525	15.10	26.05	28.65	2.73	1.08			
0.550	15.77	27.21	29.81	2.59	1.01			
0.575	16.45	28.37	30.97	2.46	0.94			
0.600	17.12	29.53	32.13	2.34	0.88			
0.625	17.79	30.69	33.29	2.23				
0.650	18.47	31.86	34.46	2.13				
0.675	19.14	33.02	35.62	2.03				
0.700	19.82	34.18	36.78	1.94				
0.725	20.46	35.30	37.90	1.86				
0.750	21.08	36.35	38.95	1.79				
0.775	21.69	37.41	40.01	1.72				
0.800	22.30	38.47	41.07	1.66				
0.825	22.91	39.52	42.12	1.60				
0.850	23.53	40.58	43.18	1.55				

Table A15.02

## System with Drophead SFK Tension force of Tension Unit SD and system prop loads



- The Drophead SFK is bolted to the PEP Slab Props.
- The PEP Props are to be assembled with the inner tube bottom.

### Considered horizontal loads

Horizontal load from erection tolerance and imperfections = 1% of the vertical load (BS 5975-2:2024; 7.2.2.3)  
 Horizontal load from legs erected out of vertical by design = Vertical load x Sin β (BS 5975- 2:2024;7.2.3)

Drophead SFK			SD Tension Unit force = 24.3kN				SD Tension Unit force = 12.15kN			
Slab Thickness (m)	Applied Load, q (kN/m)	Drophead Load (kN)	6 Connected Bays Angle β (°)	7 Connected Bays Angle β (°)	8 Connected Bays Angle β (°)	Braced Prop Load	6 Connected Bays Angle β (°)	7 Connected Bays Angle β (°)	8 Connected Bays Angle β (°)	Braced Prop Load

### SD Tension Unit Angle, a = 40°

0.150	5.38	18.54	9.04	7.66	6.63	34.14	4.22	3.53	3.02	26.34
0.175	5.99	20.66	8.05	6.81	5.89	36.26	3.73	3.11	2.65	28.46
0.200	6.60	22.77	7.25	6.12	5.28	38.37	3.33	2.77	2.35	30.57
0.225	7.21	24.88	6.58	5.55	4.79	40.48	3.00	2.49	2.10	32.68
0.250	7.83	27.00	6.02	5.07	4.37	42.60	2.72	2.25	1.89	34.80
0.275	8.44	29.11					2.48	2.04	1.72	36.91
0.300	9.04	31.17					2.28	1.87	1.56	38.97
0.325	9.71	33.50					2.08	1.70	1.42	41.30
0.350	10.38	35.82					1.91	1.55	1.29	43.62

### SD Tension Unit Angle, a = 45°

0.150	5.38	18.54	8.31	7.04	6.08	35.74	3.86	3.22	2.75	27.14
0.175	5.99	20.66	7.40	6.25	5.40	37.86	3.40	2.84	2.41	29.26
0.200	6.60	22.77	6.66	5.62	4.84	39.97	3.04	2.52	2.13	31.37
0.225	7.21	24.88	6.04	5.09	4.38	42.08	2.73	2.26	1.90	33.48
0.250	7.83	27.00					2.47	2.03	1.71	35.60
0.275	8.44	29.11					2.25	1.85	1.54	37.71
0.300	9.04	31.17					2.06	1.89	1.40	39.77
0.325	9.71	33.50					1.88	1.53	1.27	42.10

Table A15.03

## System with Drophead SFK Tension force of Tension Unit SD and system prop loads

Drophead SFK			SD Tension Unit force = 24.3kN				SD Tension Unit force = 12.15kN			
Slab Thickness (m)	Applied Load, q (kN/m)	Drophead Load (kN)	6 Connected Bays Angle β (°)	7 Connected Bays Angle β (°)	8 Connected Bays Angle β (°)	Braced Prop Load	6 Connected Bays Angle β (°)	7 Connected Bays Angle β (°)	8 Connected Bays Angle β (°)	Braced Prop Load

### SD Tension Unit Angle, a = 50°

0.150	5.38	18.54	7.48	6.33	5.46	37.14	3.45	2.87	2.44	27.84
0.175	5.99	20.66	6.65	5.62	4.84	39.26	3.03	2.52	2.13	29.96
0.200	6.60	22.77	5.98	5.04	4.34	41.37	2.70	2.23	1.88	32.07
0.225	7.21	24.88	5.42	4.56	3.92	43.48	2.42	1.99	1.67	34.18
0.250	7.83	27.00					2.19	1.79	1.50	36.30
0.275	8.44	29.11					1.99	1.82	1.35	38.41
0.300	9.04	31.17					1.82	1.48	1.22	40.47
0.325	9.71	33.50					1.65	1.33	1.09	42.80

### SD Tension Unit Angle, a = 60°

0.150	5.38	18.54	5.72	4.82	4.14	39.54	2.57	2.12	1.78	29.04
0.175	5.99	20.66	5.07	4.27	3.66	41.66	2.25	1.84	1.54	31.16
0.200	6.60	22.77	4.55	3.82	3.27	43.77	1.99	1.62	1.35	33.27
0.225	7.21	24.88					1.77	1.43	1.18	35.38
0.250	7.83	27.00					1.58	1.28	1.05	37.50
0.275	8.44	29.11					1.43	1.14	0.93	39.61
0.300	9.04	31.17					1.30	1.03	0.83	41.67
0.325	9.71	33.50					1.17	0.92	0.73	44.00

Table A15.03



# A15 Inclined slabs



## System with Prophead SSK Maximum permissible slab inclination with Tension Sleeve SAO and Chain 3.0 kN

### Considered horizontal loads

Horizontal load from erection tolerance and imperfections = 1% of the vertical load (BS5975-2:2024;7.2.2.3)  
 Horizontal load from legs erected out of vertical by design = Vertical load x Sin β (BS 5975-2:2024;7.2.3)

When concreting, begin at the deepest point of the slab formwork!

Prophead SSK		Panel Span = 1.5 m				
Slab thickness (m)	Applied Load, q (kN/m²)	Prophead Load (kN)	Braced Prophead Load (kN)	1 Bay Angle β (°)	2 Connected Bays Angle β (°)	3 Connected Bays Angle β (°)
0.150	5.38	18.14	20.74	4.17	1.80	1.01
0.175	5.99	20.21	22.81	3.68	1.55	
0.200	6.60	22.28	24.88	3.29	1.36	
0.225	7.21	24.34	26.94	2.96	1.19	
0.250	7.83	26.41	29.01	2.68	1.05	
0.275	8.44	28.48	31.08	2.45	0.94	
0.300	9.04	30.49	33.09	2.25		
0.325	9.71	32.77	35.37	2.05		
0.350	10.38	35.04	37.64	1.88		
0.375	11.06	37.31	39.91	1.73		
0.400	11.73	39.59	42.19	1.60		
0.425	12.40					
0.450	13.08					
0.475	13.75					
0.500	14.43					
0.525	15.10					
0.550	15.77					
0.575	16.45					
0.600	17.12					
0.625	17.79					
0.650	18.47					
0.675	19.14					
0.700	19.82					
0.725	20.46					
0.750	21.08					
0.775	21.69					
0.800	22.30					
0.825	22.91					
0.850	23.53					

Table A15.04

# A15 Inclined slabs



## System with Prophead SSK Maximum permissible slab inclination with Tension Sleeve SAO and Chain 3.0 kN

Drophead SSK		Panel Span = 0.75 m						
Slab thickness (m)	Applied Load, q (kN/m)	Prophead Load (kN)	Braced Prophead Load (kN)	1 Bay Angle β (°)	2 Connected Bays Angle β (°)	3 Connected Bays Angle β (°)	4 Connected Bays Angle β (°)	5 Connected Bays Angle β (°)
0.150	5.38	9.07	11.67	8.94	4.17	2.59	1.80	1.32
0.175	5.99	10.10	12.70	7.96	3.68	2.26	1.55	1.13
0.200	6.60	11.14	13.74	7.16	3.29	2.00	1.36	0.97
0.225	7.21	12.17	14.77	6.50	2.96	1.78	1.19	
0.250	7.83	13.20	15.80	5.95	2.68	1.60	1.05	
0.275	8.44	14.24	16.84	5.47	2.45	1.44	0.94	
0.300	9.04	15.25	17.85	5.07	2.25	1.31		
0.325	9.71	16.38	18.98	4.68	2.05	1.18		
0.350	10.38	17.52	20.12	4.34	1.88	1.06		
0.375	11.06	18.66	21.26	4.04	1.73	0.96		
0.400	11.73	19.79	22.39	3.77	1.60			
0.425	12.40	20.93	23.53	3.54	1.48			
0.450	13.08	22.07	24.67	3.32	1.37			
0.475	13.75	23.21	25.81	3.13	1.28			
0.500	14.43	24.34	26.94	2.96	1.19			
0.525	15.10	25.48	28.08	2.80	1.11			
0.550	15.77	26.62	29.22	2.66	1.04			
0.575	16.45	27.75	30.35	2.52	0.98			
0.600	17.12	28.89	31.49	2.40	0.91			
0.625	17.79	30.03	32.63	2.29				
0.650	18.47	31.16	33.76	2.19				
0.675	19.14	32.30	34.90	2.09				
0.700	19.82	33.44	36.04	2.00				
0.725	20.46	34.53	37.13	1.92				
0.750	21.08	35.56	38.16	1.84				
0.775	21.69	36.60	39.20	1.78				
0.800	22.30	37.63	40.23	1.71				
0.825	22.91	38.66	41.26	1.65				
0.850	23.53	39.70	42.30	1.59				

Table A15.04

## System with Prophead SSK Tension force of Tension Unit SD and prop loads

### Considered horizontal loads

Horizontal load from erection tolerance and imperfections = 1% of the vertical load (BS 5975-2:2024;7.2.2.3)  
 Horizontal load from legs erected out of vertical by design = Vertical load x Sin β (BS 5975-2:2024;7.2.3)

When concreting, begin at the deepest point of the slab formwork!

Prophead SSK			SD Tension Unit force = 24.3kN				SD Tension Unit force = 12.5kN			
Slab Thickness (m)	Applied Load, q (kN/m²)	Drophead Load (kN)	6 Connected Bays Angle β (°)	7 Connected Bays Angle β (°)	8 Connected Bays Angle β (°)	Braced Prop Load	6 Connected Bays Angle β (°)	7 Connected Bays Angle β (°)	8 Connected Bays Angle β (°)	Braced Prop Load

### SD Tension Unit Angle, a = 40°

0.150	5.38	18.14	9.26	7.84	6.79	33.74	4.33	3.63	3.10	25.94
0.175	5.99	20.21	8.24	6.98	6.03	35.81	3.82	3.20	2.72	28.01
0.200	6.60	22.28	7.42	6.27	5.42	37.88	3.42	2.85	2.42	30.08
0.225	7.21	24.34	6.74	5.69	4.91	39.94	3.08	2.56	2.16	32.14
0.250	7.83	26.41	6.16	5.20	4.48	42.01	2.79	2.31	1.95	34.21
0.275	8.44	28.48					2.55	2.10	1.77	36.28
0.300	9.04	30.49					2.34	1.92	1.61	38.29
0.325	9.71	32.77					2.14	1.75	1.46	40.57

### SD Tension Unit Angle, a = 45°

0.150	5.38	18.14	8.51	7.21	6.23	35.34	3.96	3.31	2.82	26.74
0.175	5.99	20.21	7.58	6.41	5.53	37.41	3.49	2.91	2.48	28.81
0.200	6.60	22.28	6.82	5.76	4.96	39.48	3.12	2.59	2.19	30.88
0.225	7.21	24.34	6.19	5.22	4.49	41.54	2.80	2.32	1.96	32.94
0.250	7.83	26.41					2.54	2.09	1.76	35.01
0.275	8.44	28.48					2.31	1.90	1.59	37.08
0.300	9.04	30.49					2.12	1.74	1.45	39.09
0.325	9.71	32.77					1.93	1.58	1.31	41.37

### SD Tension Unit Angle, a = 50°

0.150	5.38	18.14	7.66	6.48	5.59	36.74	3.54	2.95	2.51	27.44
0.175	5.99	20.21	6.81	5.76	4.96	38.81	3.11	2.59	2.19	29.51
0.200	6.60	22.28	6.13	5.17	4.45	40.88	2.77	2.29	1.94	31.58
0.225	7.21	24.34	5.56	4.68	4.02	42.94	2.49	2.05	1.72	33.64
0.250	7.83	26.41					2.25	1.84	1.54	35.71
0.275	8.44	28.48					2.04	1.67	1.39	37.78
0.300	9.04	30.49					1.87	1.52	1.26	39.79
0.325	9.71	32.77					1.70	1.38	1.13	42.07

Table A15.05

Slab thickness d [m]	Load q* [kN/m²]	Main Beam SLT 225								Main Beam SLT 150							
		Panel span c 1.50 m				Panel span c 0.75 m				Panel span c 1.50 m				Panel span c 0.75 m			
		Prop load [kN]		Deflection line**		Prop load [kN]		Deflection line**		Prop load [kN]		Deflection line**		Prop load [kN]		Deflection line**	
			with Centre Support SSK		with Centre Support SSK		with Centre Support SSK		with Centre Support SSK		with Centre Support SSK		with Centre Support SSK		with Centre Support SSK		with Centre Support SSK
0.14	5.13	17.7		7		8.8		7		11.9		7					
0.16	5.62	19.4		7		9.7		7		13.1		7					
0.18	6.11	21.1		7		10.5		7		14.2		7					
0.20	6.60	22.8		7		11.4		7		15.3		7					
0.22	7.09	24.5		7		12.2		7		16.5		7					
0.24	7.58	26.2		7		13.1		7		17.6		7					
0.25	7.83	27.0		7		13.5		7		18.2		7					
0.26	8.07	27.8		7		13.9		7		18.8		7					
0.28	8.56	29.5	16.2	7	7	14.8		7		19.9		7					
0.30	9.05	31.2	17.2	7	7	15.6		7		21.0		7					
0.35	10.38	35.8	19.7	7	7	17.9		7		24.1		7					
0.40	11.73	40.5	22.3	6	7	20.2		7		27.3		7					
0.43	12.54	43.3	23.6	6	6	21.4		7		29.2		6					
0.45	13.08		24.8		6	22.6		7		30.4		6					
0.50	14.43		27.4		6	24.9		7		33.5		6					
0.52	14.96		28.4		6	25.8		7	7	34.8		6		17.4		7	
0.55	15.77					27.2		7	7					18.3		7	
0.60	17.12					29.5	17.7	7	7					19.9		7	
0.65	18.47					31.9	19.1	7	7					21.5		7	
0.70	19.82					34.2	20.5	6	7					23.0		7	
0.75	21.08					36.4	21.8	6	7					24.5		7	
0.80	22.30					38.5	23.1	6	7					25.9		7	
0.85	23.53					40.6	24.3	6	7					27.3		7	
0.90	24.75					42.7	25.6	6	7					28.8		6	
0.95	25.98						26.9		7					30.2		6	
1.00	27.20						28.2		6					31.6		6	
1.05	28.43						29.4		6					33.0		6	
1.09	29.35						30.4		6					34.1		6	

**\*Load according to BS 5975:**

Dead load  $Q_1 = 0.20 \text{ kN/m}^2$

Concrete load  $Q_{2,b} = 24.5 \text{ kN/m}^3 \times d \text{ [m]}$

Equivalent load concreting  $Q_4 = 0.10 \times Q_{2,b}$   
 $0.75 \text{ kN/m}^2 \leq Q_4 \leq 1.75 \text{ kN/m}^2$

Equivalent load working conditions  $Q_{2,p} = 0.75 \text{ kN/m}^2$

Total load  $Q = Q_1 + Q_{2,b} + Q_{2,p} + Q_4$

When calculating the prop load, the actual extension length may be used. The exact extension length of the slab prop when using the SKYDECK Drop-head is:  
clear room height minus 0.41 m.  
Prop loads over 33.3 kN:  
bolting on of Drophead for use with PEP Slab Props using 2 Bolts DIN EN ISO 4016 M12 x 40-4.6 galv., Mu.

\*\*Deflection according to DIN 18202, assuming perfect levelling.

Slab thickness d [m]	Load q* [kN/m²]	Main Beam SLT 225				Main Beam SLT 150							
		Panel span c 1.50 m		Panel span c 0.75 m		Panel span c 1.50 m		Panel span c 0.75 m					
		Prop load [kN]		Deflection line**		Prop load [kN]		Deflection line**					
			with Centre Support SSK		with Centre Support SSK		with Centre Support SSK		with Centre Support SSK				
0.14	5.13	17.3		7		8.7		7					
0.16	5.62	19.0		7		9.5		7		11.5		7	
0.18	6.11	20.6		7		10.3		7		12.6		7	
0.20	6.60	22.3		7		11.1		7		13.7		7	
0.22	7.09	23.9		7		12.0		7		14.9		7	
0.24	7.58	25.6		7		12.8		7		16.0		7	
0.25	7.83	26.4		7		13.2		7		17.1		7	
0.26	8.07	27.2		7		13.6		7		17.6		7	
0.28	8.56	28.9	16.2	7	7	14.4		7		18.2		7	
0.30	9.05	30.5	17.1	7	7	15.3		7		19.3		7	
0.35	10.38	35.0	19.6	7	7	17.5		7		20.4		7	
0.40	11.73	39.6	22.2	6	7	19.8		7		23.4		7	
0.43	12.54	42.3	23.7	6	6	21.2		7		26.4		7	
0.45	13.08		24.7		6	22.1		7		28.2		6	
0.50	14.43		27.3		6	24.3		7		29.4		6	
0.55	15.77		29.8		6	26.6		7		32.5		6	
0.60	17.12					28.9		7		35.5		6	17.7
0.65	18.47					31.2	19.0	7	7			19.3	7
0.70	19.82					33.4	20.4	7	7			20.8	7
0.75	21.08					35.6	21.7	6	7			22.3	7
0.80	22.30					37.6	23.0	6	7			23.7	7
0.85	23.53					39.7	24.2	6	7			25.1	7
0.90	24.75					41.8	25.5	6	7			26.5	7
0.95	25.98						26.7	7				27.8	6
1.00	27.20						28.0	6				29.2	6
1.05	28.43						29.3	6				30.6	6
1.09	29.35						30.2	6				32.0	6
												33.0	6

**\*Load according to BS 5975:**

Dead load  $Q_1 = 0.20 \text{ kN/m}^2$

Concrete load  $Q_{2,b} = 24.5 \text{ kN/m}^3 \times d \text{ [m]}$

Equivalent load concreting  $Q_4 = 0.10 \times Q_{2,b}$   
 $0.75 \text{ kN/m}^2 \leq Q_4 \leq 1.75 \text{ kN/m}^2$

Equivalent load working conditions  $Q_{2,p} = 0.75 \text{ kN/m}^2$

Total load  $Q = Q_1 + Q_{2,b} + Q_{2,p} + Q_4$

When calculating the prop load, the actual extension length may be used. The exact extension length of the prop when using the SKYDECK Prophead is: clear room height minus 0.33 m.

\*\*Deflection according to DIN 18202, assuming perfect levelling.

**Panel system**

Slab thickness d [m]	Load q* [kN/m²]	Prop load [kN]	* Deflection to DIN 18202, Line
0.14	5.13	5.78	7
0.16	5.62	6.33	7
0.18	6.11	6.88	7
0.20	6.61	7.43	7
0.22	7.10	7.98	7
0.24	7.59	8.53	7
0.25	7.83	8.81	7
0.26	8.08	9.09	7
0.28	8.57	9.64	7
0.30	9.06	10.19	7
0.35	10.39	11.69	7
0.40	11.74	13.21	7
0.42	12.28	13.82	6
0.45	13.09	14.73	6
0.50	14.44	16.24	6
0.55	15.79	17.76	6

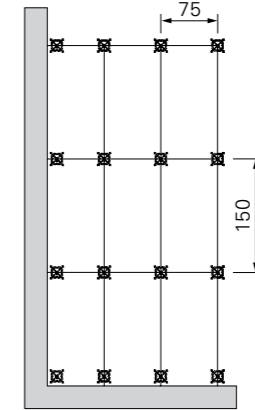

\* Deflection according to DIN 18202. Assuming perfect levelling.

**Calculation basis:**

\*Load according to BS 5975

Dead load  $Q_1 = 0.20 \text{ kN/m}^2$

Concrete load  $Q_{2,b} = 24.5 \text{ kN/m}^3 \times d \text{ [m]}$

Equivalent load concreting  $Q_4 = 0.10 \times Q_{2,b}$   
 $0.75 \text{ kN/m}^2 \leq Q_4 \leq 1.75 \text{ kN/m}^2$

Equivalent load working conditions  $Q_{2,p} = 0.75 \text{ kN/m}^2$

Total load  $Q = Q_1 + Q_{2,b} + Q_{2,p} + Q_4$

**Striking guide values\* [days] for the Drophead System**

Slab thickness d [m]	Required concrete strength $f_{ck,cube}$ [N/mm²]	*Guide values for striking time [days] for panels and main beams at an average curing temperature [°C] of		
		5°	10°	20°
0.14	15	10	6	5
0.16	13	8	5	4
0.18	11	6	4	3
0.20	9	5	3	2
0.22	8	4	3	2
0.25	7	4	2	2
0.30	6	3	2	2
0.35	5	3	2	1
0.40-1.09	5	2	1	1

**The required concrete strength at the time of striking is decisive. This is to be calculated using suitable methods.**

Guidelines according to DIN 1045, e.g. curing, must also be taken into account. A minimum of 1.88 cm²/m (Q 188) is required for the bottom reinforcement layer. For systems without any centre support of the main beams, a live load of 1 kN/m² on the slab which was struck early, is to be considered.

\* Guide values according to Leonhard for cement Z 35, CEM I 32,5 R.

### Perm. width B [m] of the filler plate

Slab thickness d [m]	Case 1	Case 2
	Fin Ply 21 mm Spruce 400 parallel/cross	Fin Ply 21 mm Spruce 400 parallel/cross
0.14	0.65	0.71
0.16	0.62	0.69
0.18	0.60	0.68
0.20	0.58	0.65
0.22	0.57	0.64
0.24	0.55	0.63
0.25	0.55	0.61
0.26	0.54	0.61
0.28	0.53	0.60
0.30	0.52	0.59
0.35	0.49	0.58
0.40	0.47	0.56
0.43	0.46	0.54
0.45	0.46	0.53
0.50	0.44	0.52
0.52	0.44	0.51
0.55	0.43	0.51
0.60	0.42	0.50
0.65	0.41	0.49
0.70	0.40	0.48
0.75	0.39	0.47
0.80	0.39	0.46
0.85	0.38	0.46
0.90	0.37	0.45
0.95	0.37	0.45
1.00	0.36	0.44
1.05	0.36	0.44
1.09	0.35	0.43

Case 1

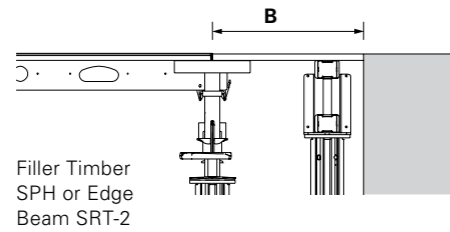

Case 2

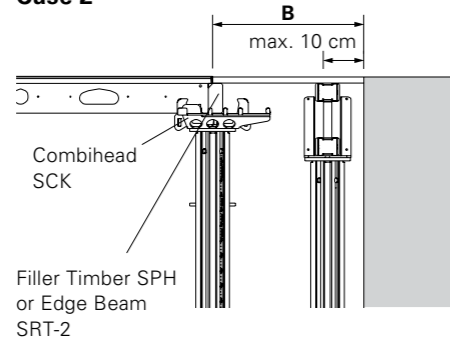

Note:  
Deflection single span beam B/300.

### Perm. width of influence $e_B$ [m] for shuttering columns

Slab thickness d [m]	Panel 150 L/500 = 3 mm		Panel 75 L/500 = 1,5 mm	
	SRT-2	SPH	SRT-2	SPH
0.14	1.14	0.49		
0.16	1.01	0.43		
0.18	0.90	0.38		
0.20	0.81	0.35		
0.22	0.74	0.32		
0.24	0.68	0.29		
0.25	0.65	0.28		
0.26	0.63	0.27		
0.28	0.59	0.25		
0.30	0.55	0.23		
0.35	0.47	0.20		
0.40	0.41	0.18		
0.43	0.39	0.16	1.70	0.72
0.45	0.37	0.16	1.63	0.69
0.50	0.33	0.14	1.48	0.63
0.52	0.32	0.14	1.43	0.61
0.55			1.35	0.57
0.60			1.25	0.53
0.65			1.16	0.49
0.70			1.08	0.46
0.75			1.01	0.43
0.80			0.96	0.41
0.85			0.91	0.38
0.90			0.86	0.37
0.95			0.82	0.35
1.00			0.78	0.33
1.05			0.75	0.32
1.09			0.73	0.31

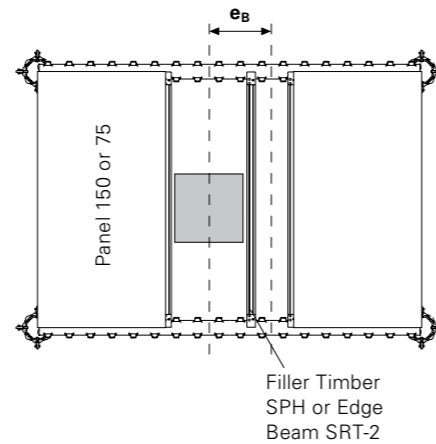

### Perm. span L [m] of the Edge Main Beams

Beam used	Slab thickness [m]										
	0.20	0.30	0.40	0.50	0.60	0.70	0.80	0.90	1.00	1.05	1.09
GT 24	4.61	3.93	3.45	3.12	2.86	2.66	2.51	2.26	2.06	1.97	1.91
VT 20	3.89	3.32	2.92	2.63	2.42	2.22	1.97	1.78	1.62	1.55	1.50
KH 10/16	3.79	3.23	2.84	2.56	2.35	2.10	1.86	1.68	1.53	1.46	1.42

### Perm. width B [m] of the filler plate max. 0.40 m

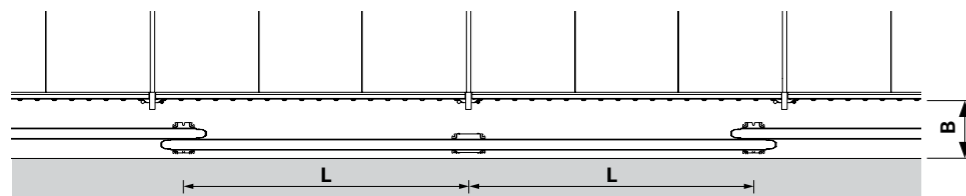

### Permissible prop load [kN] according to type test

Extension length [m]	PEP 20-300 L = 1.71 – 3.00 m		PEP 20-350 L = 1.96 – 3.50 m		PEP 20-400 L = 2.21 – 4.00 m		PEP 20-500 L = 2.71 – 5.00 m	
	Lower Outer Tube	Lower Inner Tube	Lower Outer Tube	Lower Inner Tube	Lower Outer Tube	Lower Inner Tube	Lower Outer Tube	Lower Inner Tube
1.60								
1.70								
1.80	36.4	36.4						
1.90	36.4	36.4						
2.00	36.1	36.4	36.4	36.4				
2.10	33.2	36.4	36.4	36.4				
2.20	31.4	36.4	36.4	36.4				
2.30	29.9	36.4	36.4	36.4	36.4	36.4		
2.40	28.7	36.4	36.4	36.4	36.4	36.4		
2.50	27.7	36.4	36.4	36.4	36.4	36.4		
2.60	26.9	36.3	34.8	36.4	36.4	36.4		
2.70	25.7	32.7	33.4	36.4	36.4	36.4		
2.80	24.0	29.3	32.1	36.4	36.4	36.4	36.4	36.4
2.90	22.3	26.5	31.1	36.4	36.4	36.4	36.4	36.4
3.00	20.5	23.9	30.1	36.4	36.4	36.4	36.4	36.4
3.10			28.3	35.7	34.6	36.4	36.4	36.4
3.20			26.5	32.5	33.5	36.4	36.4	36.4
3.30			24.8	29.7	32.1	36.4	36.4	36.4
3.40			23.1	27.2	30.5	36.4	36.4	36.4
3.50			21.3	24.8	28.7	34.9	36.4	36.4
3.60					26.9	32.1	36.4	36.4
3.70					25.3	29.8	36.4	36.4
3.80					23.7	27.6	36.4	36.4
3.90					22.3	25.5	36.4	36.4
4.00					20.7	23.5	35.3	36.4
4.10							33.3	36.4
4.20							31.5	36.4
4.30							29.8	35.0
4.40							28.2	32.9
4.50							26.8	30.8
4.60							25.3	28.9
4.70							24.1	27.2
4.80							22.8	25.7
4.90							21.5	24.1
5.00							20.3	22.1
5.10								
5.20								
5.30								
5.40								
5.50								

### Notes:

- PEP 20 Props conform to DIN EN 1065 Class D, i.e. the permissible prop load for all extension lengths is at least 20 kN.
- When using PERI Slab Tables, the permissible load for all PEP 20 Props is a minimum of 30 kN over the entire extension length due to the clamping in the Table Swivel Head or UNIPORTAL Head.

Permissible prop load [kN] according to type test

Overall height [m] (prop extension + 50 cm)	PEP 20-300 with MP 50		PEP 20-350 with MP 50		PEP 20-400 with MP 50		PEP 20-500 with MP 50	
	Lower Outer Tube	Lower Inner Tube	Lower Outer Tube	Lower Inner Tube	Lower Outer Tube	Lower Inner Tube	Lower Outer Tube	Lower Inner Tube
1.60								
1.70								
1.80								
1.90								
2.00								
2.10								
2.20								
2.30	36.0	36.0						
2.40	36.0	36.0						
2.50	34.9	36.0	36.0	36.0				
2.60	31.8	36.0	36.0	36.0				
2.70	29.6	36.0	36.0	36.0				
2.80	27.8	36.0	36.0	36.0	36.0	36.0		
2.90	26.4	35.8	36.0	36.0	36.0	36.0		
3.00	25.2	32.1	35.0	36.0	36.0	36.0		
3.10	24.2	28.8	32.9	36.0	36.0	36.0		
3.20	23.1	26.3	31.1	36.0	36.0	36.0		
3.30	21.4	23.9	29.7	36.0	36.0	36.0	36.0	36.0
3.40	19.9	21.8	28.4	34.2	35.7	36.0	36.0	36.0
3.50	18.1	19.8	27.0	30.7	33.9	36.0	36.0	36.0
3.60			25.3	28.6	32.3	36.0	36.0	36.0
3.70			23.6	26.1	30.8	35.3	36.0	36.0
3.80			22.0	24.2	29.1	32.7	36.0	36.0
3.90			20.4	22.5	27.3	30.0	36.0	36.0
4.00			18.9	20.7	25.5	27.8	36.0	36.0
4.10					23.9	26.1	36.0	36.0
4.20					22.4	24.2	36.0	36.0
4.30					21.0	22.8	35.6	36.0
4.40					19.7	21.2	33.6	36.0
4.50					18.3	19.7	31.6	34.2
4.60							29.3	32.1
4.70							28.0	30.0
4.80							26.5	28.4
4.90							25.1	26.8
5.00							23.8	25.4
5.10							22.6	24.0
5.20							21.4	22.7
5.30							20.3	21.6
5.40							19.1	20.4
5.50							18.1	19.1

Permissible prop load [kN] according to type test

Extension length [m]	PEP 30-150 L = 0.96 – 1.50 m		PEP 30-250 L = 1.46 – 2.50 m		PEP 30-300 L = 1.71 – 3.00 m		PEP 30-350 L = 1.96 – 3.50 m		PEP 30-400 L = 2.21 – 4.00 m	
	Lower Outer Tube	Lower Inner Tube	Lower Outer Tube	Lower Inner Tube	Lower Outer Tube	Lower Inner Tube	Lower Outer Tube	Lower Inner Tube	Lower Outer Tube	Lower Inner Tube
1.00	36.4	36.4								
1.10	36.4	36.4								
1.20	36.4	36.4								
1.30	35.9	36.4								
1.40	35.3	36.4								
1.50	34.5	36.4	42.9	42.9						
1.60			42.9	42.9						
1.70			42.9	42.9						
1.80			42.1	42.9	42.9	42.9				
1.90			39.7	42.9	42.9	42.9				
2.00			37.9	42.9	42.9	42.9	45.5	45.5		
2.10			36.4	42.9	42.9	42.9	45.5	45.5		
2.20			35.5	42.9	42.9	42.9	45.5	45.5		
2.30			34.3	41.5	42.9	42.9	45.5	45.5	41.5	41.5
2.40			33.1	38.7	42.7	42.9	45.5	45.5	41.5	41.5
2.50			31.0	35.9	41.1	42.9	45.5	45.5	41.5	41.5
2.60					40.0	42.9	45.5	45.5	41.5	41.5
2.70					38.5	42.9	45.5	45.5	41.5	41.5
2.80					36.9	41.6	45.5	45.5	41.5	41.5
2.90					34.2	38.3	45.0	45.5	41.5	41.5
3.00					31.3	34.8	43.6	45.5	41.5	41.5
3.10							41.4	44.2	41.5	41.5
3.20							38.7	42.1	41.5	41.5
3.30							36.1	38.7	41.5	41.5
3.40							33.3	35.7	41.5	41.5
3.50							30.7	32.5	41.5	41.5
3.60									41.5	41.5
3.70									41.3	41.5
3.80									38.5	41.3
3.90									35.9	38.1
4.00									33.2	34.9
4.10										
4.20										
4.30										
4.40										
4.50										

**Notes:**

- All PEP 30 Props conform to DIN EN 1065 Class E, i.e. the permissible prop load for all extension lengths is at least 30 kN.
- When using PERI Slab Tables, the permissible load for all PEP 30 Props is a minimum of 40 kN (PEP 30-150 = 35 kN) over the entire extension range due to the clamping in the Table Swivel Head or UNIPORTAL Head.

Permissible prop load [kN] according to the type test

Total length [m] (extension length + 50 cm)	PEP 30-250 with MP 50		PEP 30-300 with MP 50		PEP 30-350 with MP 50		PEP 30-400 with MP 50	
	Lower Outer Tube	Lower Inner Tube	Lower Outer Tube	Lower Inner Tube	Lower Outer Tube	Lower Inner Tube	Lower Outer Tube	Lower Inner Tube
1.00								
1.10								
1.20								
1.30								
1.40								
1.50								
1.60								
1.70								
1.80								
1.90								
2.00	36.0	36.0						
2.10	36.0	36.0						
2.20	36.0	36.0						
2.30	36.0	36.0	36.0	36.0				
2.40	36.0	36.0	36.0	36.0				
2.50	35.0	36.0	36.0	36.0	36.0	36.0		
2.60	33.2	36.0	36.0	36.0	36.0	36.0		
2.70	31.8	36.0	36.0	36.0	36.0	36.0		
2.80	30.6	36.0	36.0	36.0	36.0	36.0	36.0	36.0
2.90	28.4	32.3	36.0	36.0	36.0	36.0	36.0	36.0
3.00	26.7	28.5	36.0	36.0	36.0	36.0	36.0	36.0
3.10			36.0	36.0	36.0	36.0	36.0	36.0
3.20			33.9	36.0	36.0	36.0	36.0	36.0
3.30			32.1	34.2	36.0	36.0	36.0	36.0
3.40			29.4	31.2	36.0	36.0	36.0	36.0
3.50			26.9	27.9	36.0	36.0	36.0	36.0
3.60					35.8	36.0	36.0	36.0
3.70					33.4	34.5	36.0	36.0
3.80					30.9	31.8	36.0	36.0
3.90					28.6	29.6	36.0	36.0
4.00					26.3	27.1	36.0	36.0
4.10							36.0	36.0
4.20							35.3	36.0
4.30							33.0	33.9
4.40							30.8	31.4
4.50							28.4	29.0

Permissible prop load [kN] according to approval

Extension length [m]	PEP Ergo B-300 L = 1.97 – 3.00 m		PEP Ergo B-350 L = 2.25 – 3.50 m	
	Lower Outer Tube	Lower Inner Tube	Lower Outer Tube	Lower Inner Tube
2.00	30.8	30.8		
2.10	29.8	30.8		
2.20	27.0	30.8		
2.30	24.6	30.8	30.8	28.6
2.40	23.0	30.8	28.6	28.6
2.50	21.5	30.8	25.5	28.6
2.60	20.3	29.5	23.1	28.4
2.70	19.3	27.5	21.3	28.0
2.80	18.3	24.8	19.8	27.4
2.90	16.9	22.3	18.6	26.1
3.00	15.6	20.2	17.5	24.4
3.10			16.3	22.8
3.20			15.2	20.8
3.30			14.3	19.0
3.40			13.2	17.4
3.50			12.4	15.7
3.60				
3.70				
3.80				
3.90				
4.00				

**Note:**

- PERI PEP Ergo B-300 and PEP Ergo B-350 props meet the load-bearing capacity requirements of Prop Class B as stipulated in DIN EN 1065.
- General Technical Approval Z-8.311-934 issued by the German Institute for Structural Engineering.

PEP Ergo B with Base MP50

Total length [m] (extension length + 50 cm)	PEP Ergo B-300 with MP 50		PEP Ergo B-350 with MP 50	
	Lower Outer Tube	Lower Inner Tube	Lower Outer Tube	Lower Inner Tube
2.00				
2.10				
2.20				
2.30				
2.40				
2.50	30.8	30.8		
2.60	29.3	30.8		
2.70	26.3	30.8		
2.80	23.8	30.8	30.8	30.5
2.90	21.8	30.8	28.1	30.2
3.00	20.4	28.3	25.0	29.6
3.10	19.2	25.1	22.4	28.9
3.20	18.1	22.5	20.6	27.5
3.30	16.9	20.4	19.0	25.0
3.40	15.6	18.6	17.7	22.6
3.50	14.3	16.9	16.5	20.5
3.60			15.2	18.7
3.70			14.1	16.9
3.80			13.1	15.0
3.90			12.2	13.4
4.00			11.2	11.9

Permissible prop load [kN] according to approval

Extension length [m]	PEP Ergo D-150 L = 0.98 - 1.50		PEP Ergo D-250 L = 1.47 - 2.50 m		PEP Ergo D-300 + L = 1.79 - 3.00 m		PEP Ergo D-350 + L 2.08 - 3.50 m		PEP Ergo D-400 L = 2.51 - 4.00 m		PEP Ergo D-500 L = 3.26 - 5.00 m	
	Lower Outer Tube	Lower Inner Tube	Lower Outer Tube	Lower Inner Tube	Lower Outer Tube	Lower Inner Tube	Lower Outer Tube	Lower Inner Tube	Lower Outer Tube	Lower Inner Tube	Lower Outer Tube	Lower Inner Tube
1.00	30.8	30.8										
1.10	30.8	30.8										
1.20	30.8	30.8										
1.30	30.8	30.8										
1.40	28.5	30.8										
1.50	26.4	30.8	35.0	35.0								
1.60			35.0	35.0								
1.70			32.9	35.0								
1.80			30.7	35.0	35.0	35.0						
1.90			29.1	35.0	35.0	35.0						
2.00			28.1	35.0	35.0	35.0						
2.10			27.3	35.0	35.0	35.0	40.0	40.0				
2.20			26.5	34.1	35.0	35.0	40.0	40.0				
2.30			25.7	32.3	33.4	35.0	40.0	40.0				
2.40			24.3	29.4	31.7	34.0	39.7	40.0				
2.50			22.4	26.3	30.1	32.7	36.9	40.0				
2.60					28.3	31.3	34.7	40.0				
2.70					26.2	29.1	32.9	40.0	40.0	40.0		
2.80					24.3	26.9	31.6	40.0	40.0	40.0		
2.90					22.4	24.9	30.3	40.0	40.0	40.0		
3.00					20.6	22.8	29.2	39.1	40.0	40.0		
3.10							27.2	35.4	37.7	40.0		
3.20							25.4	32.1	35.7	40.0		
3.30							23.7	29.4	33.9	40.0	40.0	40.0
3.40							22.1	27.0	32.5	40.0	40.0	40.0
3.50							20.7	24.7	31.0	39.7	40.0	40.0
3.60									29.0	36.4	40.0	40.0
3.70									27.0	33.3	40.0	40.0
3.80									25.2	30.7	40.0	40.0
3.90									23.5	28.2	40.0	40.0
4.00									21.8	26.0	40.0	40.0
4.10											39.3	40.0
4.20											36.5	40.0
4.30											34.0	39.2
4.40											31.8	37.0
4.50											29.9	34.6
4.60											28.1	32.4
4.70											26.4	30.4
4.80											24.8	28.5
4.90											23.4	26.8
5.00											21.8	25.3
5.10												
5.20												
5.30												
5.40												
5.50												

- Notes:**
- PERI PEP Ergo D-150, PEP Ergo D-250, PEP Ergo D-300, PEP Ergo D-350 +, PEP Ergo D-400 and PEP Ergo D-500 props fulfil the Prop Class D load-bearing capacity requirements of DIN EN 1065.
  - The PEP Ergo D-250 fulfils the Prop Class B requirements aof DIN EN 1065.
  - General Technical Approval Z-8.311-934 for PERI PEP Ergo D-150 and PEP Ergo D-250 and PEP Ergo D-300 +.
  - General Technical Approval Z-8.311-941 for PERI PEP Ergo D-350 +, PEP Ergo D-400 and PEP Ergo D-500.

Permissible prop load [kN]

Total length [m] (extension length + 50 cm)	PEP Ergo D-250 with MP 50		PEP Ergo D-300 + with MP 50		PEP Ergo D-350 + with MP 50		PEP Ergo D-400 with MP 50		PEP Ergo D-500 with MP 50	
	Lower Outer Tube	Lower Inner Tube	Lower Outer Tube	Lower Inner Tube	Lower Outer Tube	Lower Inner Tube	Lower Outer Tube	Lower Inner Tube	Lower Outer Tube	Lower Inner Tube
1.00										
1.10										
1.20										
1.30										
1.40										
1.50										
1.60										
1.70										
1.80										
1.90										
2.00	36.4	37.9								
2.10	35.2	37.9								
2.20	31.9	37.9								
2.30	29.3	37.9	35.0	35.0						
2.40	27.6	37.9	35.0	35.0						
2.50	26.2	36.0	35.0	35.0						
2.60	25.1	33.8	35.0	35.0	40.0	40.0				
2.70	24.2	30.3	34.3	35.0	40.0	40.0				
2.80	23.3	27.0	31.8	33.9	40.0	40.0				
2.90	21.7	24.3	30.0	32.4	38.6	40.0				
3.00	19.8	21.9	27.6	30.3	35.6	40.0				
3.10			25.2	27.4	33.2	40.0	40.0	40.0		
3.20			23.2	25.0	31.2	40.0	40.0	40.0		
3.30			21.3	23.0	29.6	36.7	40.0	40.0		
3.40			19.7	21.1	28.2	33.1	40.0	40.0		
3.50			18.1	19.3	26.3	30.2	38.8	40.0		
3.60					24.4	27.7	36.0	40.0		
3.70					22.7	25.5	34.0	40.0		
3.80					21.2	23.6	32.0	36.9	40.0	40.0
3.90					19.7	21.8	30.1	33.6	40.0	40.0
4.00					18.2	20.2	27.9	30.9	40.0	40.0
4.10							25.9	28.7	40.0	40.0
4.20							24.1	26.6	40.0	40.0
4.30							22.5	24.7	40.0	40.0
4.40							21.0	22.9	39.8	40.0
4.50							19.5	21.3	36.9	38.7
4.60									34.4	36.0
4.70									32.1	33.7
4.80									30.0	31.6
4.90									28.1	29.7
5.00									26.5	28.0
5.10									24.9	26.4
5.20									23.4	24.9
5.30									22.1	23.5
5.40									20.8	22.6
5.50									19.5	21.0

**Permissible prop load [kN] according to approval**

Extension length [m]	PEP Ergo E-300 + L = 1.79 – 3.00 m		PEP Ergo E-350 + L = 2.08 – 3.50 m		PEP Ergo E-400 L = 2.51 – 4.00 m	
	Lower Outer Tube	Lower Inner Tube	Lower Outer Tube	Lower Inner Tube	Lower Outer Tube	Lower Inner Tube
1.80	50.4	50.4				
1.90	50.4	50.4				
2.00	50.4	50.4				
2.10	50.4	50.4	50.4	50.4		
2.20	50.4	50.4	50.4	50.4		
2.30	50.4	50.4	50.4	50.4		
2.40	47.3	50.4	50.4	50.4		
2.50	45.6	50.4	50.4	50.4		
2.60	44.5	50.4	50.4	50.4	50.4	50.4
2.70	43.3	50.4	48.5	50.4	50.4	50.4
2.80	41.8	50.4	46.4	50.4	50.4	50.4
2.90	40.3	48.0	44.5	50.4	50.4	50.4
3.00	37.5	43.0	43.0	50.4	50.4	50.4
3.10			41.5	50.4	50.4	50.4
3.20			38.7	46.1	50.4	50.4
3.30			36.0	41.9	50.4	50.4
3.40			33.3	38.2	50.4	50.4
3.50			30.9	34.9	48.5	50.4
3.60					46.0	50.4
3.70					42.7	48.4
3.80					39.7	44.7
3.90					36.9	41.1
4.00					34.1	37.7
4.10						
4.20						
4.30						
4.40						
4.50						

**Notes:**

- PERI Props PERI PEP Ergo E-300 +, PEP Ergo E-350 + and PEP Ergo E-400 fulfil the Prop Class E load-bearing capacity requirements of DIN EN 1065.
- General Building Approval Z-8.311-941 of the German Institute for Structural Engineering (DIBt).

**Permissible prop load [kN]**

Total length [m] (extended length + 50 cm)	PEP Ergo E-300 + with MP 50		PEP Ergo E-350 + with MP 50		PEP Ergo E-400 with MP 50	
	Lower Outer Tube	Lower Inner Tube	Lower Outer Tube	Lower Inner Tube	Lower Outer Tube	Lower Inner Tube
1.80						
1.90						
2.00						
2.10						
2.20						
2.30	50.4	50.4				
2.40	50.4	50.4				
2.50	50.4	50.4				
2.60	50.4	50.4	50.4	50.4		
2.70	50.1	50.4	50.4	50.4		
2.80	47.0	50.4	50.4	50.4		
2.90	44.8	50.4	50.4	50.4		
3.00	43.0	50.4	50.4	50.4		
3.10	41.0	50.4	50.4	50.4	50.4	50.4
3.20	39.3	47.0	49.5	50.4	50.4	50.4
3.30	38.1	42.0	46.7	49.9	50.4	50.4
3.40	35.4	37.8	42.9	45.6	50.4	50.4
3.50	32.3	34.2	39.4	41.7	50.4	50.4
3.60			36.3	38.2	50.4	50.4
3.70			33.5	35.3	50.4	50.4
3.80			31.1	32.6	49.3	50.4
3.90			28.8	30.2	46.2	48.4
4.00			26.6	27.9	42.7	44.6
4.10					39.6	41.2
4.20					36.8	38.2
4.30					34.3	35.5
4.40					31.8	33.0
4.50					29.5	30.5

Permissible prop load [kN] according to type test

Extension length [cm]	MP 250 L = 1.45 – 1.20 m		MP 350 L = 1.95 – 3.50 m		MP 480 L = 2.60 – 4.80 m		MP 625 L = 4.30 – 6.25 m	
	Lower Outer Tube	Lower Inner Tube	Lower Outer Tube	Lower Inner Tube	Lower Outer Tube	Lower Inner Tube	Lower Outer Tube	Lower Inner Tube
80								
90								
100								
110								
120								
130								
140								
150	99.3	94.0						
160	99.3	94.0						
170	99.3	94.0						
180	97.2	94.0						
190	92.9	94.0						
200	88.7	94.0	96.0	94.7				
210	86.5	94.0	93.1	94.7				
220	84.4	94.0	90.1	94.7				
230	82.5	92.4	87.5	94.1				
240	80.9	89.2	85.1	93.1				
250	79.3	86.0	82.7	92.0				
260			79.3	88.7	88.7	94.0		
270			76.0	85.3	87.8	92.3		
280			73.3	82.7	87.0	90.7		
290			70.7	80.0	86.2	89.0		
300			68.7	77.0	85.3	87.3		
310			66.7	74.0	80.2	84.9		
320			63.1	71.0	75.1	82.5		
330			59.6	68.0	70.0	80.0		
340			54.7	61.5	66.6	77.3		
350			49.8	54.9	63.2	74.7		
360					59.7	72.0		
370					56.2	67.4		
380					52.8	62.7		
390					49.3	58.1		
400					46.3	54.1		
410					43.3	50.0		
420					40.3	45.9		
430					38.0	43.3	57.9	45.7
440					35.7	40.8	56.3	45.7
450					33.5	38.2	54.7	45.7
460					31.2	35.6	52.5	45.1
470					28.9	33.1	50.2	44.5
480					26.7	30.5	47.8	43.6
490							45.1	42.5
500							42.4	41.3
510							39.8	39.9
520							37.2	38.5
530	<b>MULTIPROP Props are classified according to official approval as follows:</b> MP 250 Class T 25                      MP 480 Class D 45 MP 350 Class R 35                      MP 625 Class D 60  <b>Note:</b> To release the loads > 60 kN, we recommend using the HD Wingnut Spanner, Item no. 022027. When using PERI Slab Tables, the permissible load of the MULTIPROP MP 350 Prop is a minimum of 56 kN and a minimum of 36 kN for the MP 480 over the entire extension length which is due to the clamping in the Table Swivel Head or UNIportal Head.						34.9	37.0
540							32.9	35.6
550							30.9	34.1
560							29.3	32.6
570							27.7	31.1
580							26.3	29.5
590							25.0	27.9
600							23.7	26.2
610							22.6	24.8
620							21.5	23.4
625							21.0	22.7

Permissible prop load [kN] to EN 16031

Overall height [cm] (prop extension + 50 cm)	MP 250 + MP 50 L = 1.95 – 3.00 m		MP 350 + MP 50 L = 2.45 – 4.00 m		MP 480 + MP 50 L = 3.10 – 5.30 m		MP 625 + MP 50 L = 4.80 – 6.75 m	
	Lower Outer Tube	Lower Inner Tube	Lower Outer Tube	Lower Inner Tube	Lower Outer Tube	Lower Inner Tube	Lower Outer Tube	Lower Inner Tube
130								
140								
150								
160								
170								
180								
190								
200	89.3	94.0						
210	89.3	94.0						
220	89.3	94.0						
225	89.3	94.0						
230	88.1	93.7						
240	85.7	93.2						
250	83.3	92.7	88.7	85.3				
260	79.9	88.9	88.7	85.3				
270	76.4	85.2	88.7	85.3				
280	72.9	80.5	86.4	85.3				
290	69.3	74.9	81.9	85.3				
300	65.7	69.3	77.3	85.3				
310			73.3	82.3	88.7	81.3		
320			69.3	79.3	86.3	81.0		
330			65.6	72.1	84.0	80.7		
340			61.8	64.9	81.7	80.3		
350			57.4	60.7	79.3	80.0		
360			53.1	56.4	73.3	75.8		
370			49.4	52.2	67.2	71.5		
380			45.7	48.0	61.2	67.3		
390			42.4	44.0	56.9	62.9		
400			39.1	40.0	52.6	58.4		
410					48.3	53.9		
420					45.5	50.1		
430					42.6	46.3		
440					39.8	42.5		
450					37.6	40.0		
460					35.5	37.5		
470					33.3	35.0		
480					31.7	33.2	48.7	44.5
490					30.0	31.4	47.5	44.4
500					28.4	29.6	46.3	44.3
510					26.8	27.8	44.6	43.1
520					25.1	26.1	42.9	41.8
530					23.5	24.3	41.1	40.4
540							39.2	38.8
550							37.3	37.1
560							35.3	35.6
570							33.3	34.0
580							31.5	32.5
590							29.8	31.0
600	<b>Note:</b> To release the loads > 60 kN, we recommend using the HD Wingnut Spanner, Item no. 022027.						28.1	29.5
610							26.7	28.1
620							25.3	26.7
630							24.1	25.4
640							22.9	24.2
650							21.8	22.9
660							20.8	21.8
670							19.8	20.6
675							19.3	20.0

## SKYDECK Panel Slab Formwork

Item no. Weight kg

Panels SDP		L	B
061000	15.500	1500	750
061011	11.700	1500	500
061020	9.780	1500	375
061010	8.560	750	750
061013	6.350	750	500
061030	5.250	750	375

Panel with 9 mm plywood.

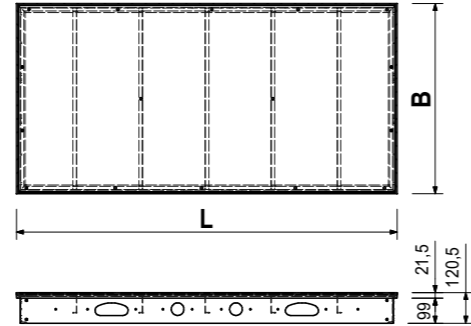
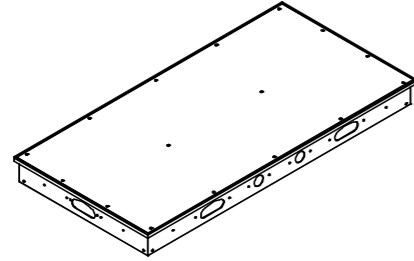

061160 25.700 **Main Beam SLT 375**  
For cantilevers.

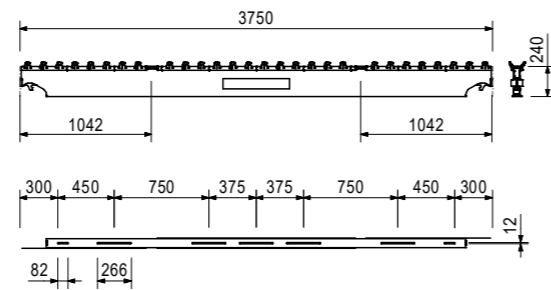
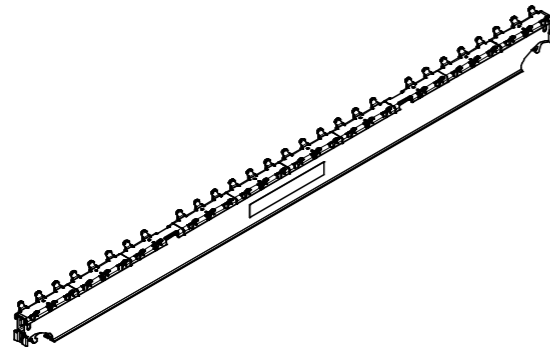

061100 15.600 **Main Beam SLT 225**  
For standard fields.

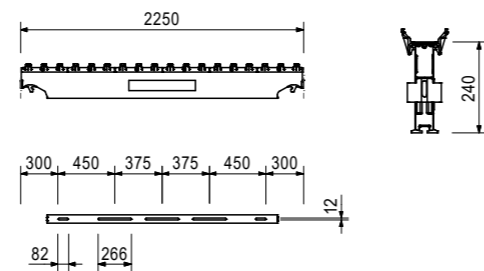
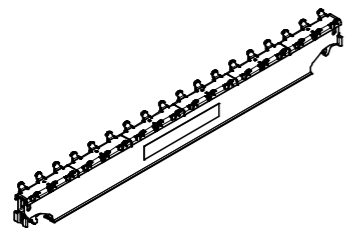

## SKYDECK Panel Slab Formwork

Item no. Weight kg

061110 9.690 **Main Beam SLT 150**  
For filler areas.

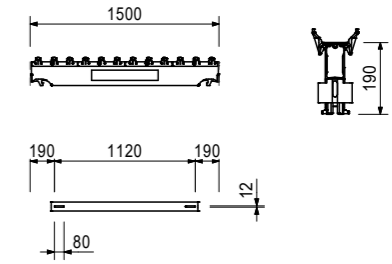
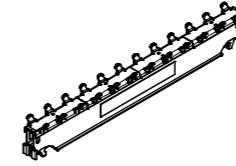

061026 1.580 **Cover Strips SAL**  
061027 0.794 **Cover Strip SAL 150**  
**Cover Strip SAL 75**  
Plastic. Panel with 21 mm plywood. For use with drophead SFK.

L
1500
750

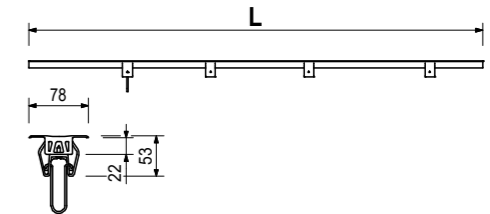
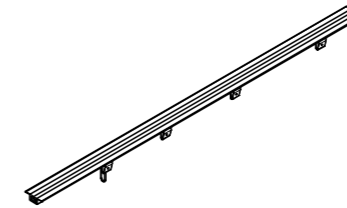

061045 5.740 **Edge Beams SRT-2**  
061046 2.720 **Edge Beam SRT-2 150**  
**Edge Beam SRT-2 75**  
For longitudinal and transverse filling, for shuttering around columns. Panel with 21 mm plywood.

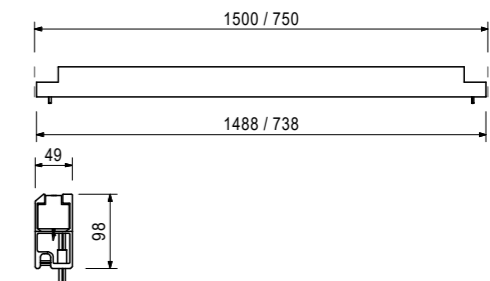
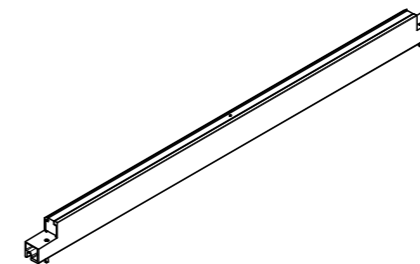

## SKYDECK Panel Slab Formwork

Item no.	Weight kg
061210	6.180

### Drophead SFK

With self-locking coupling. Supports main beam as well as cover strip and formlining. Lowering height 6 cm. For 21 mm plywood formlining.

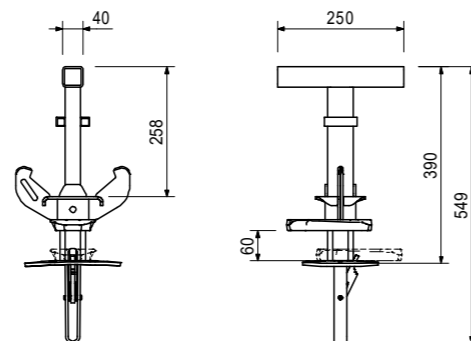
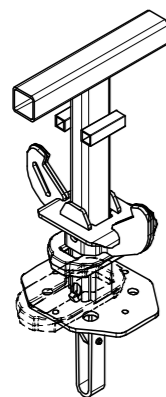

061200	3.860
--------	-------

### Prophead SSK

With self-locking coupling. Supports main beams, panels, edge girders and filler timber.

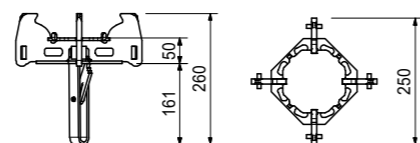
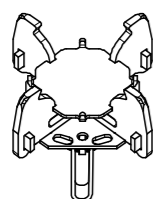

061180	5.340
--------	-------

### Combihead SCK

With self-locking coupling. Supports main beams, panels, edge girders and filler timber.

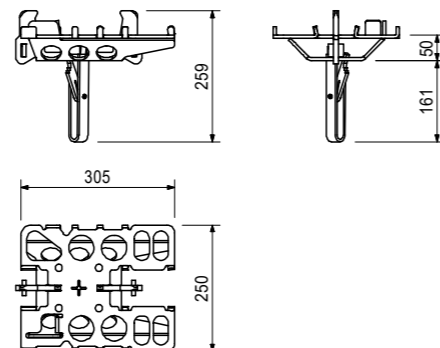
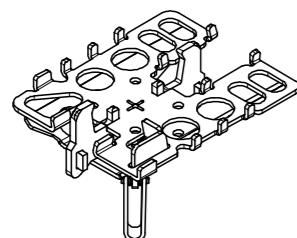

## SKYDECK Panel Slab Formwork

Item no.	Weight kg
061049	3.350
061036	5.020

### Filler Timbers SPH

#### Filler Timber SPH 150

#### Filler Timber SPH 225

For compensations with 21 mm plywood formlining.

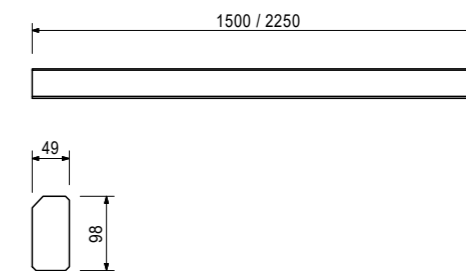
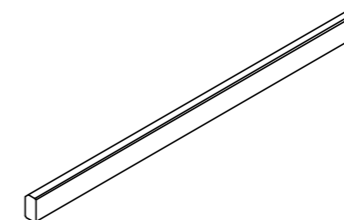

061021	8.660
061022	5.350

### Triangular Frames SDR

#### Triangular Frame SDR 150 x 75

#### Triangular Frame SDR 75 x 75

For compensations on inclined walls. For compensations with 21 mm plywood formlining.

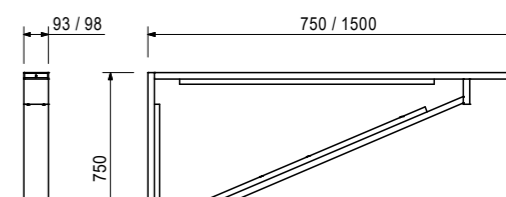
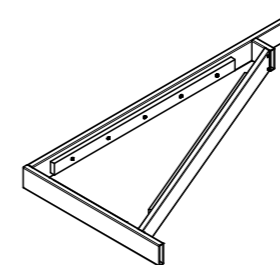

061051	5.270
--------	-------

### Wall Holder SWH-2

For horizontal anchoring at the wall. Attach to every second girder or panel.

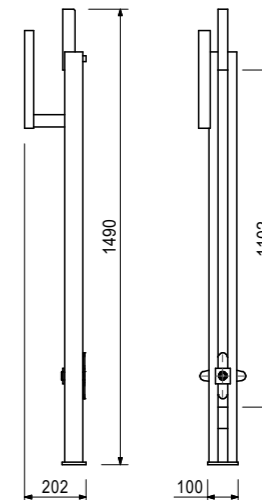

## SKYDECK Panel Slab Formwork

Item no.	Weight kg
061023	2.140

### End Support SSL

To be used as compensation to the filler area and to be fixed to the drophead SFK.

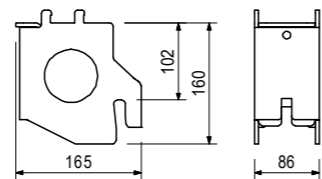
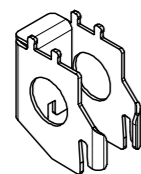

061290	0.133
--------	-------

### Panel Clip SPK

Fixes panel on main beam.

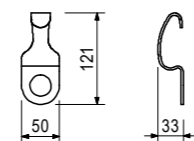

061280	0.778
--------	-------

### Panel Wedge Clip SPKK

Fixes panel on main beam.

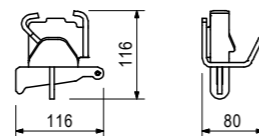

061052	2.590
--------	-------

### Table Connector STV

For assembling SKYDECK Slab Tables. Also allows the fixing of intermediate props at the main beam.

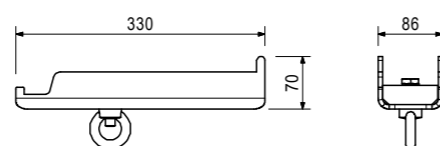
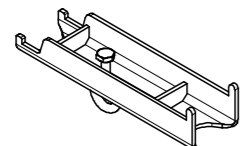

061300	2.240
--------	-------

### Erection Aid SSH

For forming with SKYDECK. Adjustable in 7.5-cm-increments.

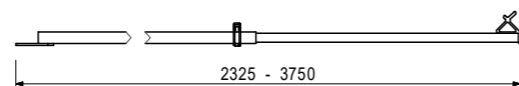
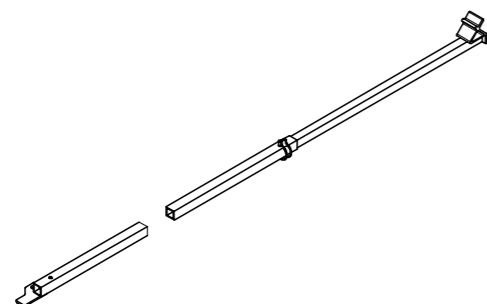

## SKYDECK Panel Slab Formwork

Item no.	Weight kg
061310	0.996

### Tension Sleeve SAO

For bracing cantilevered main beams.

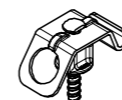

### Technical Data

Permissible tension force 3.0 kN.

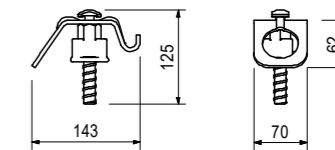

123633	12.100
--------	--------

### Tension Unit SD

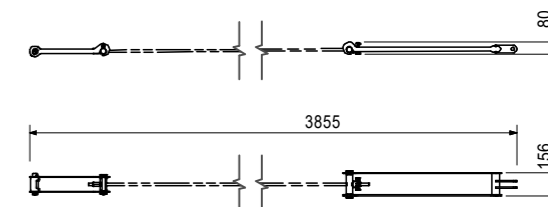
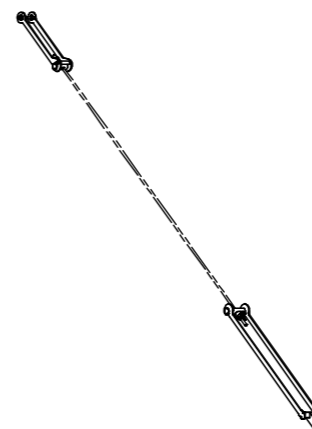

061060	108.000
--------	---------

### Platform SDB 150

Work and safety scaffold. Scaffold width 1.30 m. With continuous 39 mm thick decking and foldable handrail frame.

### Technical Data

Permissible load 150 kg/m<sup>2</sup>.

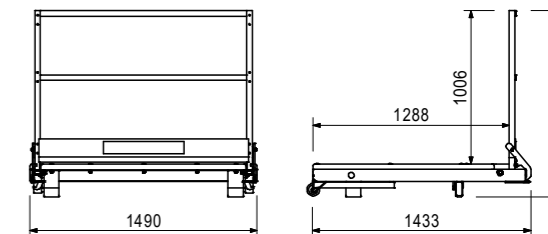
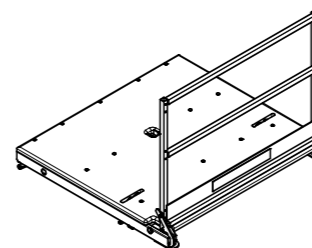

061061	153.000
--------	---------

### Platform SDB 225

Work and safety scaffold. Scaffold width 1.30 m. With continuous 39 mm thick decking and foldable handrail frame.

### Technical Data

Permissible load 150 kg/m<sup>2</sup>.

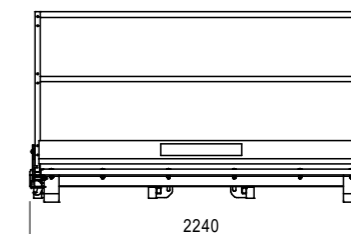
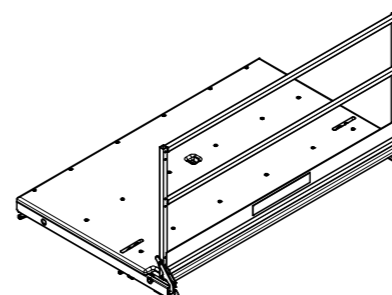

## SKYDECK Panel Slab Formwork

Item no.	Weight kg
061062	185.000

### Platform SDB 300

Work and safety scaffold. Scaffold width 1.30 m. With continuous 39 mm thick decking and foldable handrail frame.

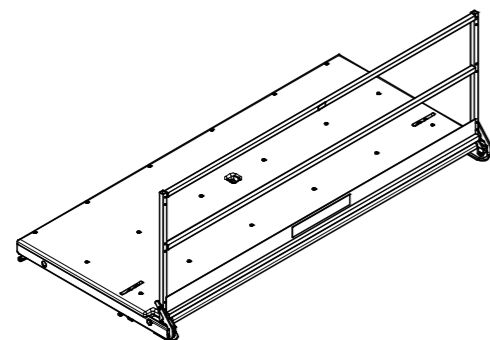

### Technical Data

Permissible load 150 kg/m<sup>2</sup>.

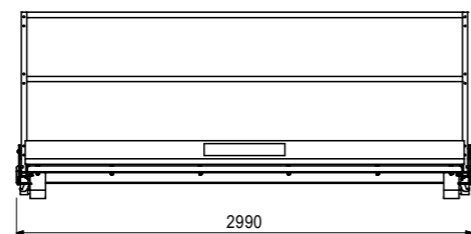

061250	4.760
--------	-------

### Guardrail Holder SGH, Alu

For assembling a guardrail with SKYDECK.

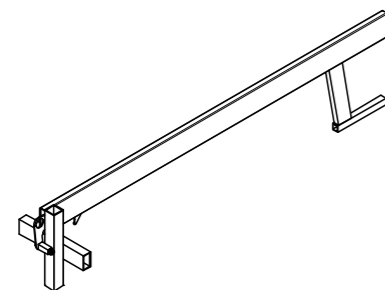

### Technical Data

Maximum width of influence 1.55 m.

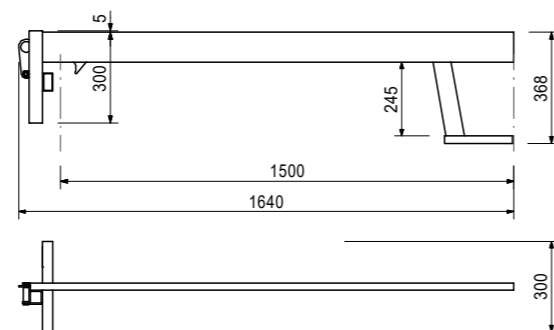

201845	1.460
--------	-------

### Handrail Post Adapter

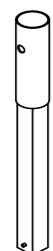

201847	4.000
--------	-------

### Safety Post 1150mm

As guardrail for different systems.



## SKYDECK Panel Slab Formwork

Item no.	Weight kg
065073	1.370

### Anchor Chain 3.0 kN, l = 2.5 m

### Technical Data

Permissible tension force 3.0 kN.

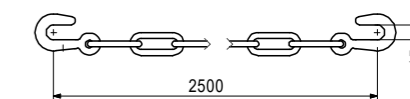
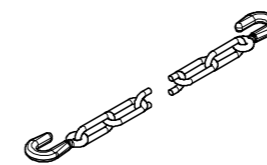

065074	0.450
--------	-------

### Turnbuckle 3.0 kN, M12

### Technical Data

Permissible tension force 3.0 kN.

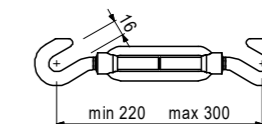
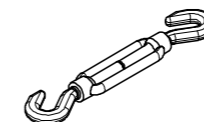

028100	1.830
--------	-------

### Base Plate for RS

For assembly of RS Push-Pull Props.

### Complete with

1 pc. 018050 Pin Ø 16 x 65/86, galv.  
1 pc. 018060 Cotter Pin 4/1, galv.

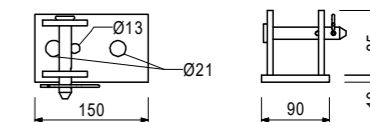
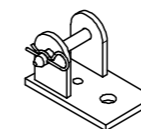

117343	3.250
--------	-------

### Base Plate-2 for RS 210 - 1400, galv.

For assembly of Push-Pull Props RS 210, 260, 300, 450, 650, 1000 and 1400.

### Complete with

2 pc. 105400 Pin Ø 20 x 140, galv.  
2 pc. 018060 Cotter Pin 4/1, galv.

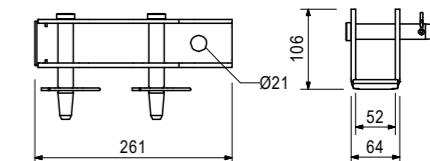
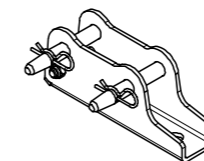

124777	0.210
--------	-------

Accessories

### Anchor Bolt PERI 14/20 x 130

124777	0.210
--------	-------

### Anchor Bolt PERI 14/20 x 130

For temporary fixation to reinforced concrete structures.

### Note

See PERI data sheet!  
Drilling Ø 14 mm.

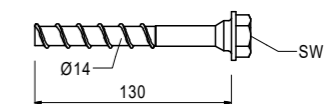
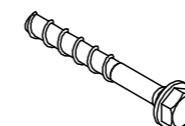

## SKYDECK Panel Slab Formwork

Item no.	Weight kg
123970	0.047

### Screw-On Sleeve PERI M16/164

For temporary mounting of components on reinforced concrete slabs.

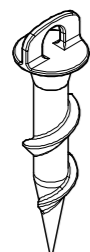

### Note

Inserted into the fresh concrete immediately after concreting.

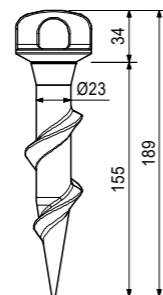

Accessories

123973	0.240
--------	-------

### Bolt ISO 4014 M16 x 130-8.8, galv.

061530	82.400
--------	--------

### Pallet SD 150 x 225, galv.

For stacking and transportation of 48 SKYDECK Panels 150 x 75.

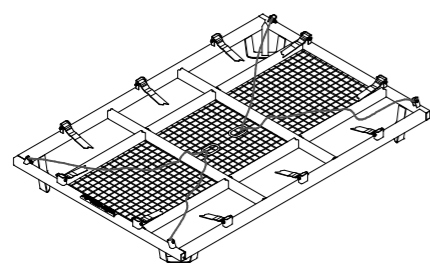

### Complete with

5 pc. 710594 Belt Spanner Unit L = 1400 mm  
3 pc. 710595 Belt Lose End L = 4200 mm  
2 pc. 710596 Belt Lose End L = 5000 mm

### Note

Follow Instructions for Use!

### Technical Data

Permissible load-bearing capacity 750 kg.

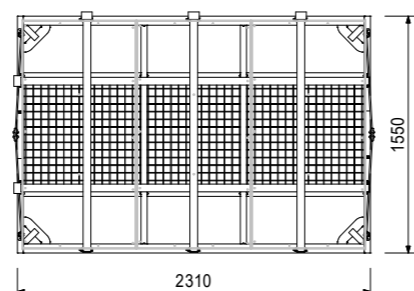
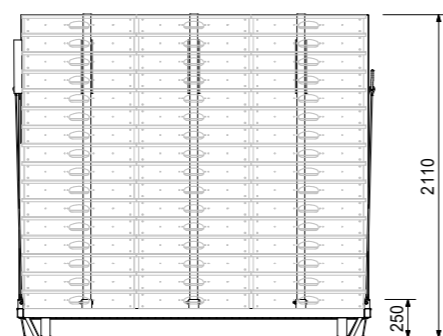

## SKYDECK Panel Slab Formwork

Item no.	Weight kg
061500	76.700

### Pallet SD 150 x 75, galv.

For stacking and transportation of 14 SKYDECK Panels 150 x 75.

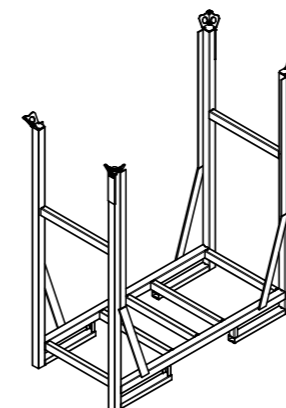

### Note

Follow Instructions for Use!

### Technical Data

Permissible load-bearing capacity 1.0 t.

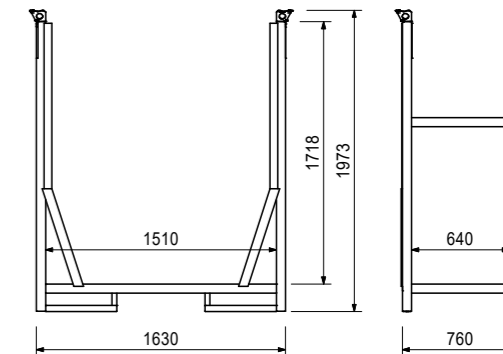

061510	105.000
--------	---------

### Pallet Lifting Trolley 1800 mm

For moving pallets and crate pallets.

### Note

Follow Instructions for Use!

### Technical Data

Forklift arm length 1800 mm, forklift arm width 550 mm, stroke range 115 mm.  
Permissible load-bearing capacity 2.0 t.

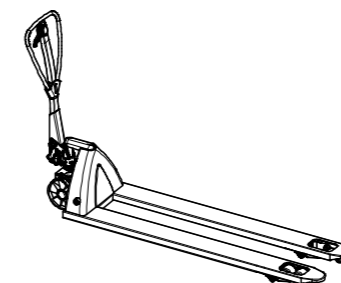

061520	403.000
--------	---------

### Transportation Fork SUG, galv.

For moving SKYDECK Slab Tables.

### Note

Follow Instructions for Use!

### Technical Data

Permissible load-bearing capacity 1.0 t.

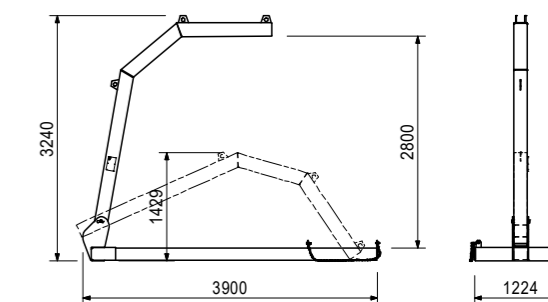
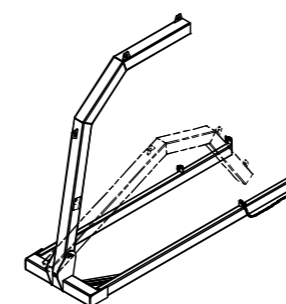

## SKYDECK Panel Slab Formwork

Item no.	Weight kg
035500	72.800

### Stripping Cart, Alu

Mobile working scaffold. Height-adjustable in 25-cm-increments. Platform height max. 2.00 m.

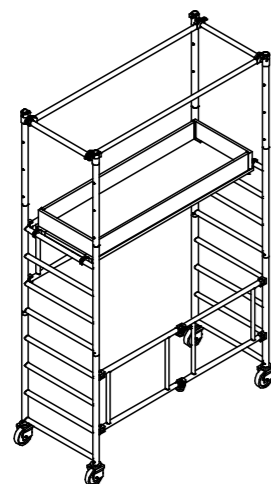

### Note

Follow Instructions for Use!

### Technical Data

Permissible load 100 kg/m<sup>2</sup>.

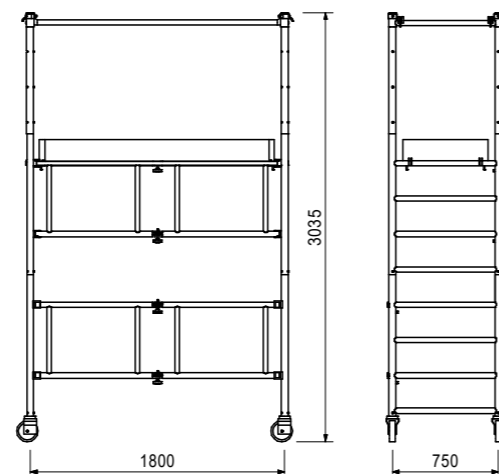

## SKYDECK Panel Slab Formwork

Item no.	Weight kg
102031	363.000

### Stripping Cart ASW 465, compl.

Mobile working scaffold. Height-adjustable in 30-cm-increments. Platform height max. 4.65 m.

Packed in:

Ring Pallet USP 104 Item no. 100678, with Lashing Strap 25 x 5750 Item no. 100707 (x 1) and Scaffold Tube Steel L = 1000 Item no. 100706 (x 6).

### Complete with

- 1 pc. 102025 Folding Base Unit 160/190 ASW
- 6 pc. 102035 Vertical Frame 70/90 ASW
- 6 pc. 102034 Vertical Frame 70/120 ASW
- 2 pc. 102026 Entry Platform 190 ASW
- 1 pc. 102030 Toe-Board Set 70/190 ASW
- 4 pc. 102027 Double Guardrail 190 ASW
- 3 pc. 102028 Diagonal Brace 210 ASW
- 2 pc. 102029 Horizontal Brace 190 ASW
- 12 pc. 102807 Ballast 10 kg ASW
- 2 pc. 103040 Lateral complete ASW
- 1 pc. 102587 Center part ASW galv.

### Note

Follow Instructions for Use!

### Technical Data

Permissible load 100 kg/m<sup>2</sup>.

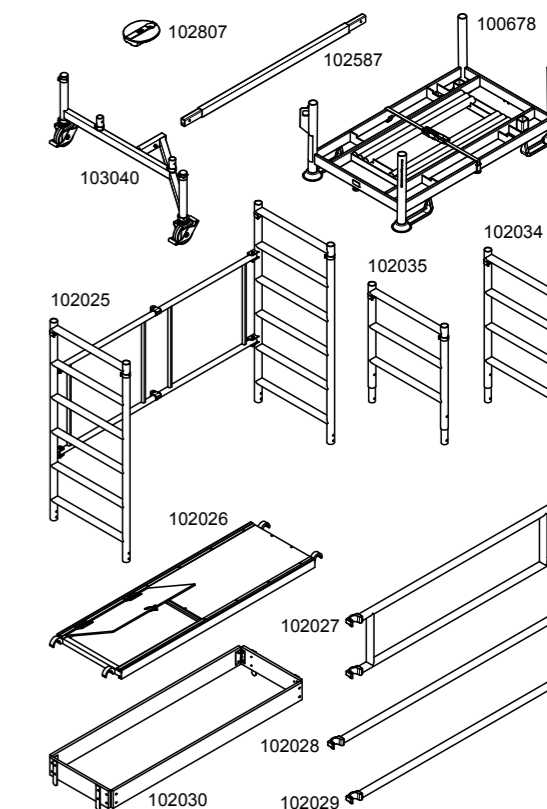
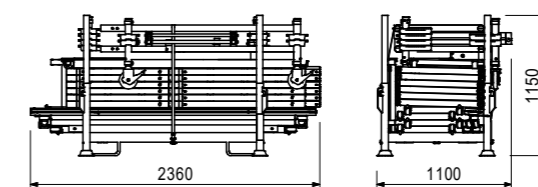
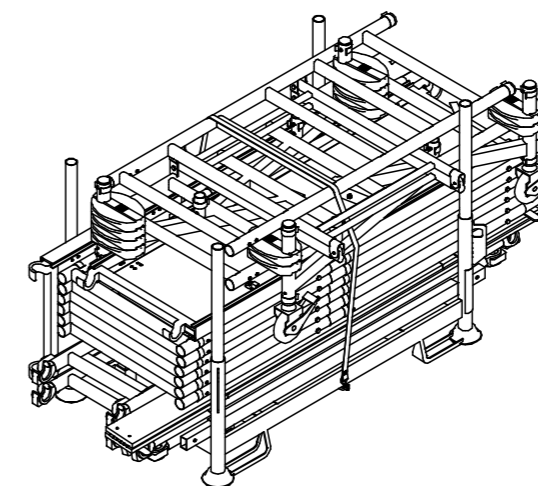

## SKYDECK Panel Slab Formwork

Item no.	Weight kg
----------	-----------

118331	13.500
118323	18.000

**Handrail Units SD**  
**Handrail Unit SD 75**  
**Handrail Unit SD 150**

For assembling a Guardrail on a casting segment with SKYDECK. Assembling in a rectangular angle on top of the Main Beams.

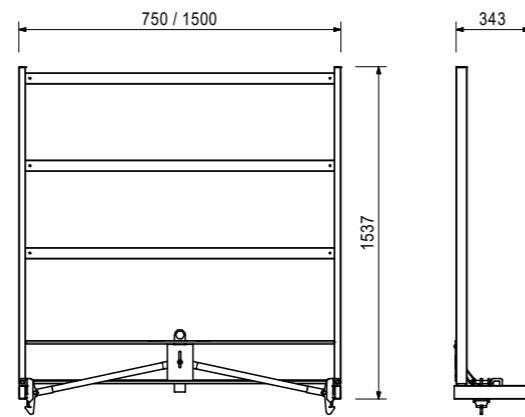
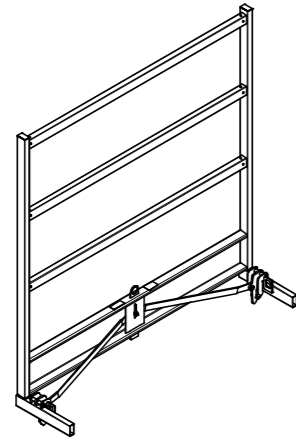

126630	123.000
--------	---------

**Pallet Handrail Unit SD 75**

For stacking and transportation of 10 SKYDECK Handrail Units SD 75.

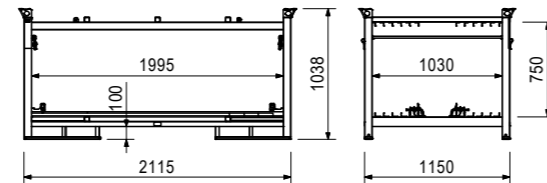
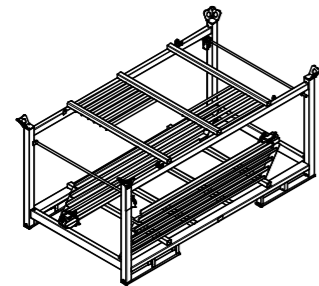

**Note**

Follow Instructions for Use!

**Technical Data**

Permissible load-bearing capacity 150 kg.

## SKYDECK Panel Slab Formwork

Item no.	Weight kg
----------	-----------

126580	134.000
--------	---------

**Pallet Handrail Unit SD 150**

For stacking and transportation of 10 SKYDECK Handrail Units SD 150.

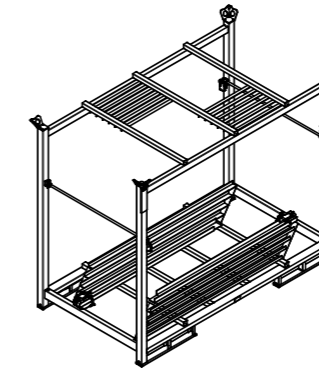

**Note**

Follow Instructions for Use!

**Technical Data**

Permissible load-bearing capacity 200 kg.

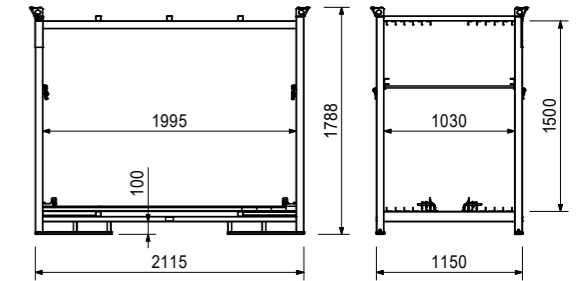

118622	4.870
--------	-------

**Transition Prophead SDSK**

For the rectangular change of the direction of the Main Beam SLT in the standard application with Prophead SSK.

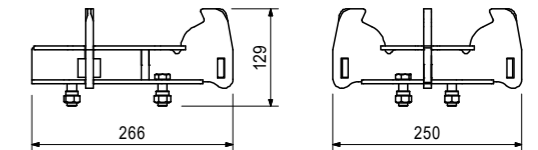
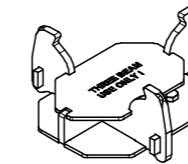

127620	6.790
--------	-------

**Transition Head SDFK**

For the rectangular change of the direction of the Main Beam SLT in the standard application with Drophead SFK.

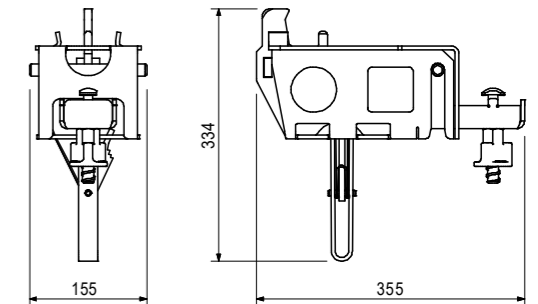
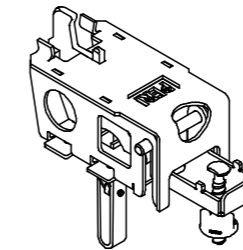

## SKYDECK Panel Slab Formwork

Item no.	Weight kg
114755	555.000

### Lifting Plattform 290

For shuttering and striking of SKYDECK Panels.

### Complete with

- 1 pc. 129377 Panel Holder SD, right
- 2 pc. 129378 Panel Holder SD, left

### Note

Follow Instruction for Use!

### Technical Data

Platform height max. 2.90 m; working height max. 4.90 m. Required tension force for the charging process 110/220 V, 50/60 Hz. Permissible load-bearing capacity 180 kg.

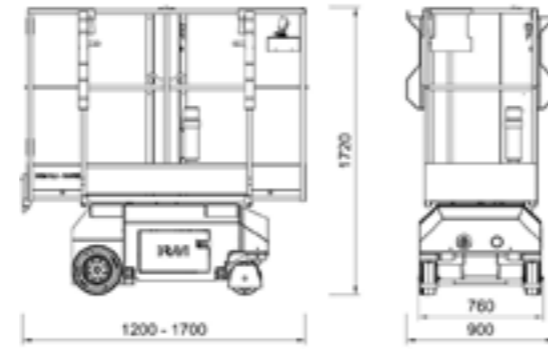



**PERI Ltd**  
**Formwork Scaffolding Engineering**  
Market Harborough Road  
Clifton upon Dunsmore  
Rugby  
CV23 0AN  
+44 (0)1788 861600  
info@peri.ltd.uk  
www.peri.ltd.uk