

PERI UP Flex

Reinforcement Scaffold 75 and 100

Instructions for Assembly and Use – Standard Configuration – Issue 03/2021
incl. supplemental pages PERI UP Flex 2nd generation

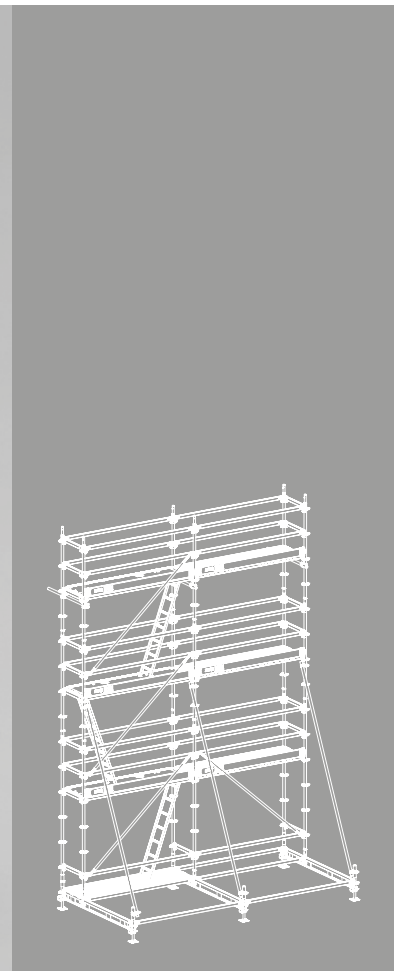
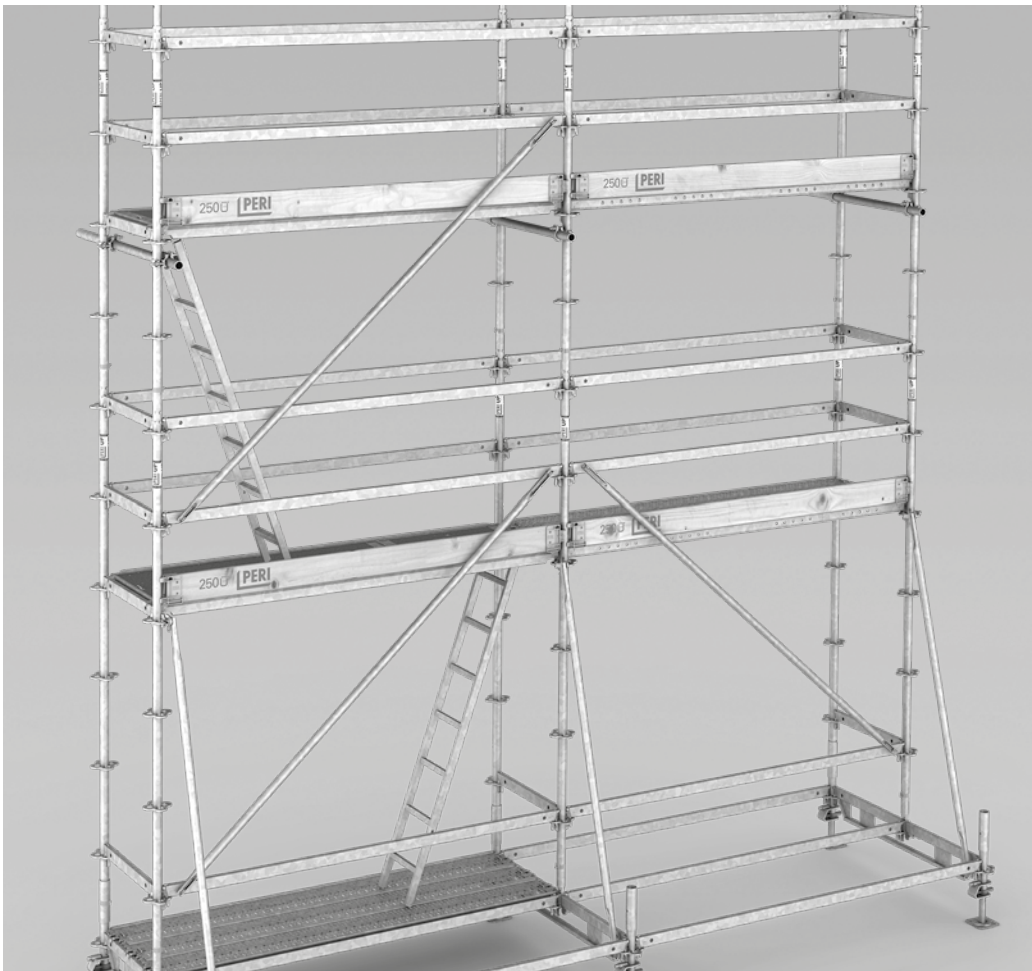

Base width 150, Ledger Heavy Duty UHV 150 Plus

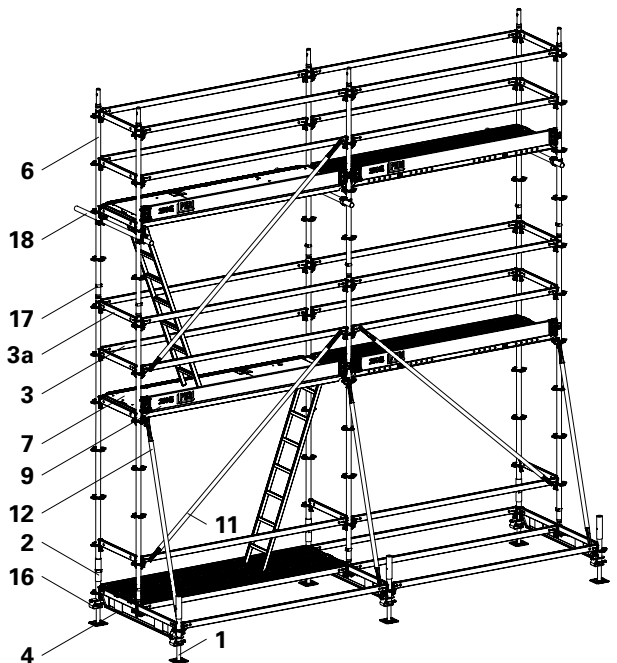
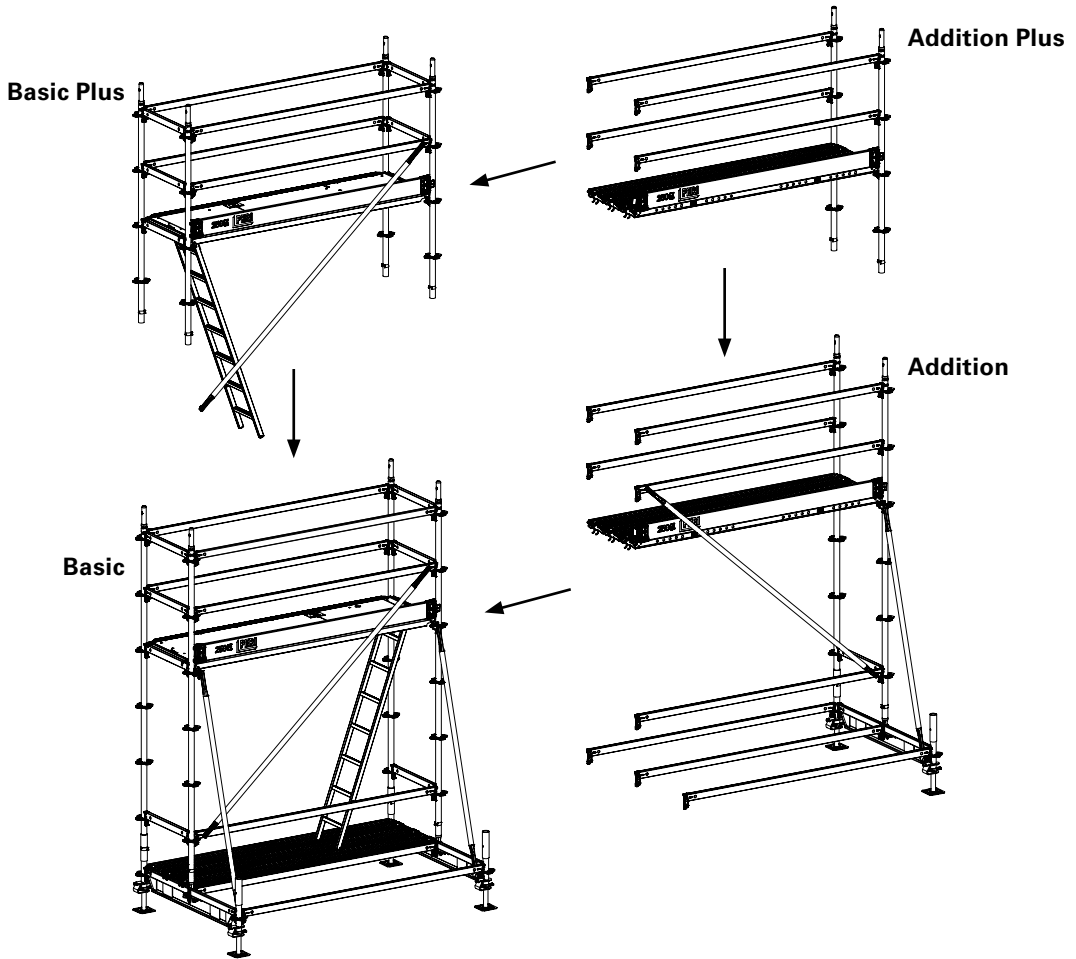

Overview

Base width 150, Ledger Heavy Duty UHV 150 Plus	3
Base width 250 cm, Ledger Heavy Duty UHV 250 Plus	4
Main components	5
Key	6
Presentational reference	6

Introduction

Target groups	7
Additional technical documentation	7
Intended use	8
Instructions on use	8
Cleaning and maintenance instructions	9

Safety instructions

Cross-system	10
System-specific	11
Storage and transportation	11
Identification markings	12
Laws and regulations	12
Inspection, hand-over and utilisation	13

Base width 150 cm

A1 Assembling the base with Ledger UHV 150	
Base level	14
Standards and Ledgers	15
Attachment of base level	16
Attachment of Standards and Ledgers	17
Access decks, decking and guardrails	18
Stability	19
A2 Assembly of Extensions	
Standards and Ledgers	20
Access decks, decking and guardrails	21
Additional levels	22
A3 Pressure-resistant ties	23
A4 Dismantling	
Recommendation	24

Base width 250 cm

B1 Assembling the base with Ledger UHV 250	
Base level	26
Standards and Ledgers	27
Attachment of base level	28
Attachment of Standards and Ledgers	29
Access decks, decking and guardrails	30
B2 Assembly of Extensions	
Standards and Ledgers	31
Access decks, decking and guardrails	32
Stability	33
Additional levels	34
B3 Pressure-resistant ties	35
B4 Dismantling	
Recommendation	36

Application

C1 Overview	
Base width 150 cm	38
Base width 250 cm	39
C2 Actions	40
C3 Reaction forces	41
C4 Anchors, anchor forces	42
C5 Ballast	43

Working Safety

D1 Moving by crane	44
D2 Working on the reinforcement scaffold	45
D3 Assembly with guardrail in advance	46

Variants

E1 Optional/alternative components	47
E2 Scaffold width 100 cm	
Base width 150 cm	48
Base width 250 cm	49
E3 Bay length 300 cm	
Scaffold width 75 cm	50
Scaffold width 100 cm	51
E4 Base Beam UVA 250	52
E5 Hatch UAF	53
E6 Coupler Braces UBC	54
E7 External stairs	55

Components

PERI UP Flex Reinforcement Scaffold 75 and 100	56
--	----

Supplemental pages

PERI UP Flex 2nd generation	I - VIII
-----------------------------	----------

Base width 250 cm, Ledger Heavy Duty UHV 250 Plus

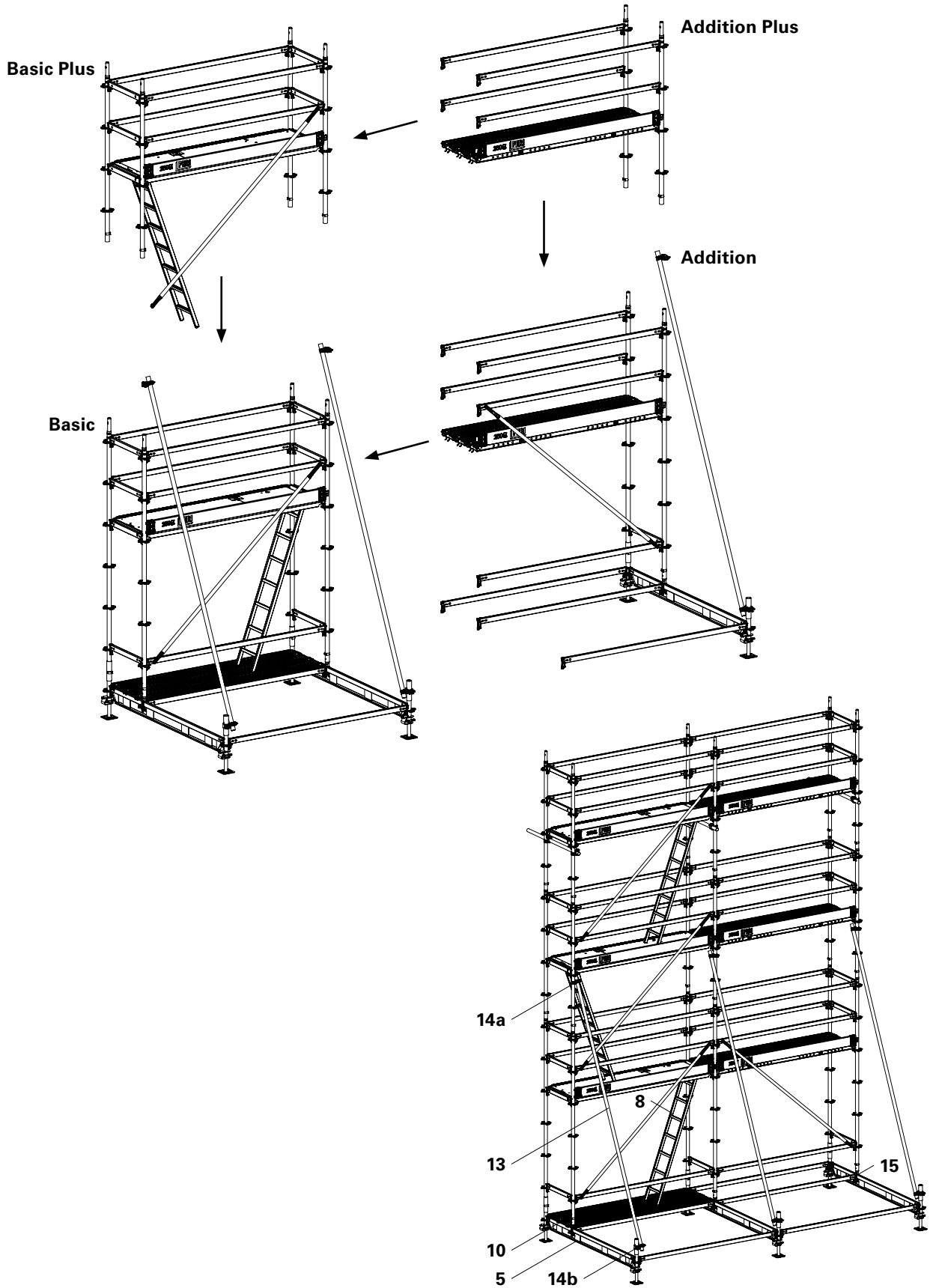

Main components

- 1 Adjustable Base Plate UJB
- 2 Base Standard UVB 24
- 3 Ledger UH Plus ¹⁾
- 3a Ledger UH 75 Plus ¹⁾
- 4 Ledger UHV 150 Plus
- 5 Ledger UHV 250 Plus
- 6 Standard UVR
- 7 Access Deck UAL-3 75 x 250/3
- 8 Ladder Flex UEL with Hook
- 9 Toeboard Wood UPF ²⁾
- 10 Steel Deck UDG ³⁾
- 11 Ledger Brace UBL
- 12 Node Brace UBK
- 13 Steel Scaffold Tube Ø 48.3 x 3.2
- 14a Swivel Coupling DK 48/48, galv.
- 14b Swivel Coupling DK 48/60, galv.
- 15 Ledger to Ledger Coupler UHA Half with Spigot
- 16 Spindle Locking UJS
- 17 Locking Pin Ø 48/57
- 18 Pressure Support (Steel Scaffold Tube Ø 48.3 x 3.2 + Standard Coupler NK 48/48)

¹⁾ Alternatively, the Ledger UH Plus can also be used instead of the Ledger UH.

²⁾ Alternatively, the Toeboard Steel UPY can also be used instead of the Toeboard Wood UPF.

³⁾ Alternatively, Industrial Decks UDI can be used instead of Steel Decks UDG.

Note

Item numbers beginning with the numbers 3 and 4 are only available as rental or used items.

Key

Pictogram | Definition



Danger / Warning / Caution



Information



To be complied with



Tip

Arrows



Arrow representing an action



Arrow representing a reaction of an action*



Forces

* if not identical to the action arrow.

Safety instruction categories

The safety instructions alert site personnel to the risks involved and provide information on how to avoid these risks. Safety instructions are featured at the beginning of the section or ahead of the instructions, and are highlighted as follows:



Danger

This sign indicates an extremely hazardous situation which, if not avoided, will result in death or serious injury.



Warning

This sign indicates a hazardous situation which, if not avoided, could result in death or serious injury.



Caution

This sign indicates a hazardous situation which, if not avoided, could result in minor or moderate injury.



Information

This sign indicates warning of situations whereby failure to observe the information can result in material damage.

Set-up of the safety instructions



Signal word

Type and source of the danger!
Consequences of non-compliance.
⇒ Avoidance measures

Dimension specifications

Dimensions are usually given in cm. Other measurement units, e.g. m, are shown in the illustrations.

Conventions

- Instructions are numbered with: 1., 2., 3.
- The result of an instruction is shown by: →
- Position numbers are clearly provided for the individual components and are given in the drawing, e.g. **1**, in the text in brackets, for example (1).
- Multiple position numbers, i.e. alternative components, are represented with a slash: e.g. **1 / 2**.

Presentational reference

The illustration on the front cover of these instructions is understood to be a system representation only. The assembly steps presented in these Instructions for Assembly and Use are shown in the form of examples with only one component size. They are valid accordingly for all component sizes contained in the standard configuration.

For a better understanding, detailed illustrations are partly incomplete. Safety installations which have possibly not been included in these detailed drawings must nevertheless still be available.

Target groups

Contractors

These Instructions for Assembly and Use are designed for contractors who use the scaffolding either for

- assembling, modifying and dismantling purposes, or use
- it, e.g. for concreting, or
- who have it used, e.g. for forming operations.

Competent person

(Construction Site Coordinator)

The Safety and Health Protection Coordinator*

- is appointed by the client,
- must identify potential hazards during the planning phase,
- determines measures that provide protection against risks,
- creates a safety and health plan,
- coordinates the protective measures for the contractor and site personnel so that they do not endanger each other,
- monitors compliance with the protective measures.

Competent person qualified to carry out inspections

Due to the specialist knowledge gained from professional training, work experience and recent professional activity, the competent person qualified to carry out inspections has a reliable understanding of safety-related issues and can correctly carry out inspections. Depending on the complexity of the test to be undertaken, e.g. scope of testing, type of testing or the use of certain measuring devices, a range of specialist knowledge is necessary.

Qualified persons

The scaffolding may only be assembled, modified or dismantled by personnel who are suitably qualified to do so. For the work to be carried out, the qualified persons must have received instructions** covering at least the following points:

- Explanation of the plan for the assembly, modification or dismantling of the scaffolding in an understandable form and language.
- Description of the measures in order to safely assemble, modify or dismantle the scaffolding.

- Designation of the preventive measures to avoid the risk of persons and objects falling.
- Designation of the safety precautions in the event of changing weather conditions which could adversely affect the safety of the scaffolding as well as the personnel concerned.
- Details regarding the permissible loads.
- Description of any other risks that are associated with the assembly, modification or dismantling procedures.



- **In other countries, ensure that the relevant national guidelines and regulations in the respective current version are complied with!**
- **If no country-specific regulations are available, it is recommended to proceed according to German guidelines and regulations.**
- **A competent person must be present on site during scaffolding operations.**

* Valid in Germany: Regulations for Occupational Health and Safety on Construction Sites 30 (RAB 30)

** Instructions are given by the contractor himself or a competent person selected by him.

Additional technical documentation

- Approvals:
 - Approval Z-8.22-863 PERI UP Flex Modular System
 - Approval Z-8.1-957 PERI UP Easy Scaffold System
- Instructions for Assembly and Use:
 - PERI UP Flex Core Components
 - PERI UP Flex Stairs 75
- Brochures:
 - PERI UP for Building Construction Projects
- Instructions for Use:
 - Pallets and Stacking Devices

Intended use

Product description

PERI products have been designed for exclusive use in the industrial and commercial sectors by qualified personnel only.

These Instructions for Assembly and Use are based on the Approval "Z-8.22-863 PERI UP Flex Modular System".

They describe the standard configuration for a reinforcement scaffold as shoring for allowing temporary work to be carried out on higher positioned working areas.

Features

The system is based on PERI UP Flex Modular Scaffold with supplementary components.

Used as working scaffold in Load Class 1-3 according to EN 12811-1:

0.75 - 2.00 kN/m².

It fulfils wind load requirements according to DIN EN 1004 and DIN EN 12811

- for free-standing scaffold according to DIN EN 1004: $q = 0.1 \text{ kN/m}^2$ ($v = 12.7 \text{ m/s}$),
- for scaffolds with base width 150 or 250 cm deviating from DIN EN 1004 in accordance with DIN EN 12811: $q = 0.2 \text{ kN/m}^2$ ($v = 17.9 \text{ m/s}$),
- different assembly variations with up to 3 bays in longitudinal direction.

Ballast is not required as long as the scaffolding is positioned in front of a wall or formwork and can be supported by this. Units can be moved by crane due to the extremely tight connections.

System dimensions

System width: 75 cm and 100 cm

Storey height: 200 cm

Scaffold bay lengths:

150/200/250/300 cm

Max. height with:

base width 150 cm: $H \leq 660 \text{ cm}$

base width 250 cm: $H \leq 1080 \text{ cm}$

(H = underside of spindle up to level of top deck)

Instructions on use

The use in a way not intended according to the Instructions for Assembly and Use, or any use deviating from the standard configuration or the intended use represents a misapplication with a potential safety risk, e.g. risk of falling.

Deviations from the standard configuration must be verified for the application by means of separate strength and stability calculations. (Industrial Safety Regulation Appendix 1, No. 3.2.1 and explicitly reflected in the assembly instructions.)

In addition to original PERI UP Flex scaffolding components, the following original PERI UP scaffold components are used for the assembly:

these must be marked with the corresponding German approval numbers

– Z-8.1 – 957 for PERI UP Easy

– Z-8.22 – 863 for PERI UP Flex

as well as with the mark of conformity <Ü>.

The use of other products and spare parts is not allowed.

Changes to PERI components are not permitted.

Cleaning and maintenance instructions

Clean the panels after each use to maintain the value and usability of the PERI products over the long term.

Some repair work may also be inevitable due to the tough working conditions. The following points should help to keep cleaning and maintenance costs as low as possible.

Do not clean powder-coated or galvanized components with steel brushes or metal scrapers.

Mechanical components, e.g. spindles, must be cleaned of dirt or concrete residue before and after use, and then greased with a suitable lubricant.

Provide suitable support for the components during cleaning so that no unintentional change in their position is possible.

Do not clean components suspended on crane lifting gear.

Any repairs to PERI products are to be carried out by PERI qualified personnel only.

Cross-system

General

The scaffolding contractor must ensure that the Instructions for Assembly and Use supplied by PERI are available at all times and are understood by the site personnel.

These Instructions for Assembly and Use can be used as the basis for creating a risk assessment. The risk assessment is compiled by the scaffolding contractor. However, these Instructions for Assembly and Use do not replace the risk assessment!

Always take into consideration and comply with the safety instructions and permissible loads.

For the application and inspection of PERI products, the current safety regulations and guidelines valid in the respective countries must be observed.

Materials and working areas are to be inspected on a regular basis, especially before each use and assembly, for:

- signs of damage,
- stability and
- function.

Damaged components must be exchanged immediately on site and may no longer be used.

Safety components are to be removed only when they are no longer required.

Components provided by the contractor must conform with the characteristics required in these Instructions for Assembly and Use as well as all valid construction guidelines and standards. Unless otherwise indicated, this applies in particular to:

- timber components: Strength Class C24 for Solid Wood according to EN 338.
- scaffold tubes: galvanised steel tubes with minimum dimensions of $\varnothing 48.3 \times 3.2$ mm according to * EN 12811-1:2003 4.2.1.2.
- scaffold tube couplings according to EN 74.

Deviations from the standard configuration are only permitted after a further risk assessment has been carried out by the contractor.

On the basis of this risk assessment, appropriate measures for working and operational safety as well as stability are to be determined.

Corresponding proof of stability can be provided by PERI on request if the risk assessment and resulting measures to be implemented are made available.

Before and after exceptional occurrences that may have an adverse effect regarding the safety of the scaffolding system, the contractor must immediately

- create an additional risk assessment, with appropriate measures for ensuring the stability of the formwork system being carried out based on the results,
- arrange for an extraordinary inspection to be carried out by a competent person qualified to do so. The aim of this inspection is to identify and rectify any damage in good time in order to guarantee the safe use of the scaffolding system.

Exceptional occurrences can include:

- accidents,
- longer periods of non-use,
- natural events, e.g. heavy rainfall, icing, heavy snowfall, storms or earthquakes.

Assembly, modification and dismantling work

Assembly, modification or dismantling of scaffolding systems may only be carried out by qualified persons and under the supervision of a competent person. The qualified persons must have received appropriate training for the work to be carried out with regard to specific risks and dangers.

On the basis of the risk assessment and Instructions for Assembly and Use, the scaffolding contractor must create installation instructions in order to ensure safe assembly, modification and dismantling of the scaffolding system.

Before initial use, the safe functioning of the scaffold must be checked by a person qualified to carry out the inspection. The results of the inspection must be documented in an inspection record.

The scaffolding contractor must ensure that the personal protective equipment required for the assembly, modification or dismantling of the scaffolding, e.g.

- safety helmet,
- safety shoes,
- safety gloves,
- safety glasses,

is available and used as intended.

If personal protective equipment (PPE) against falling from a height is required or specified in local regulations, the scaffolding contractor must determine appropriate attachment points on the basis of the risk assessment.

The PPE to prevent falling to be used is determined by the contractor.

The contractor must

- provide safe working areas for site personnel which are to be reached through the provision of safe access ways. Areas of risk must be cordoned off and clearly marked.
- ensure the stability during all stages of construction, in particular during assembly, modification and dismantling work.
- ensure and prove that all loads can be safely transferred.

Utilisation

Every contractor who uses or allows the scaffolding system or sections of the scaffolding system to be used, has the responsibility for ensuring that the equipment is in good condition.

If the scaffolding system is used successively or at the same time by several contractors, the health and safety coordinator must point out any possible mutual hazards, and all work must be then coordinated.

System-specific

Only use approved lifting gear.

In the case of a storm warning, additional measures are to be taken to supplement the available information.

Enclosure of the scaffolding or mounting of additional surfaces which are exposed to the influences of the wind changes the stability and must therefore be checked. If necessary, additional measures must be implemented.

The load-distributing support used, such as planking, must match the respective base. If several layers are required, planks are to be arranged crosswise.

Close access hatches immediately after use.

Couplers with screw closure have to be tightened using 50 Nm. This corresponds to a force of 20 kg using a lever arm length of 25 cm.

Wedge couplers are to be securely fitted using a 500 g hammer.

Storage and transportation

Store and transport components ensuring so that no unintentional change in their position is possible. Detach lifting accessories and slings from the lowered components only if they are in a stable position and no unintentional change is possible.

Do not drop the components.

Use PERI lifting accessories and slings as well as only those load-bearing points provided on the component.

During the moving procedure

- ensure that components are picked up and set down so that unintentional falling over, falling apart, sliding, falling down or rolling is avoided.
- no persons are allowed to remain under the suspended load.

Always guide pre-assembled scaffolding bays, scaffolding units or scaffolding sections with ropes when moving them by crane (see Section D1).

The access areas on the construction site must be free of obstacles and tripping hazards as well as being slip-resistant.

For transportation, the surface used must have sufficient load-bearing capacity.

Use original PERI storage and transport systems, e.g. crate pallets, pallets or stacking devices.

Inspection, hand-over and utilisation

The erected scaffolding must be inspected by the scaffolding contractor in order to determine that assembly has been carried out correctly. If the contractor is convinced that the scaffolding has been correctly erected, it can then be handed over to the user. It is advisable to carry out the hand-over together with the user and, for example, document this in a written report.

Warning

During the hand-over, the scaffold contractor must advise the user of any possible risks involved with non-intended use and his obligation to provide adequate prevention against risk and danger!

- ⇒ Put up safety and warning signs at the scaffold access points.
- ⇒ Hand-over a utilisation plan.



The contractor who uses the scaffolding must ensure that the scaffolds are maintained in proper condition and not arbitrarily altered in any way. In this respect, the qualified specialists must be instructed that if changes have obviously been made to the scaffolding construction during use, these must be reported to the respective competent person.

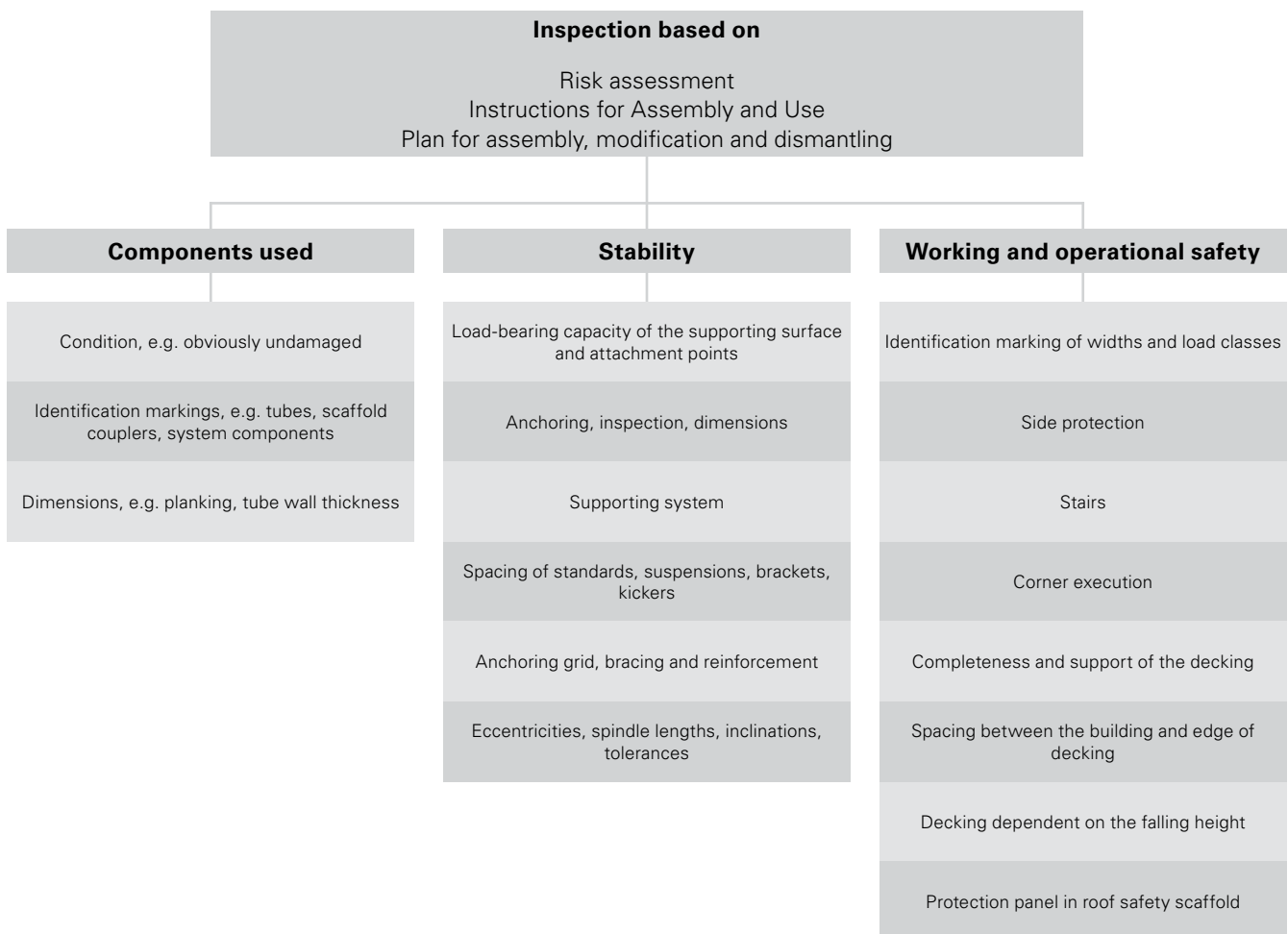

Source: based on TRBS 2121 Part 1

Base level



- Assembly of the reinforcement scaffold must always take place in front of a wall or secure formwork units!
- The surface used must have sufficient load-bearing capacity.

Pos.	Component	Qty.
1	Adjustable Base Plate UJB	4x
2	Base Standard UVB 24	4x
3	Ledger UH Plus	2x
4	Ledger UHV 150 Plus	2x
10	Steel Deck UDG	3x
16	Spindle Locking UJS	4x

Assembly

1. Assemble frame.
2. Horizontally align frame by adjusting the Adjustable Base Plates.
Max. spindle adjustment range for
 - Base Plate UJB 38-50/30: ≤ 26 cm
 - Base Plate UJB 38-80/55: ≤ 39 cm
3. Establish perpendicularity of the base.
4. Secure wedges on all ledgers using a 500 g hammer.
(Fig. A1.01a + A1.01b + A1.01c)
5. Insert Steel Deck UDG (10).
→ Lift-off prevention devices drop under the UH Ledger (4) and secure the decking.
6. Secure Adjustable Base Plate UJB with Spindle Locking UJS (16).
(Fig. A1.01d)

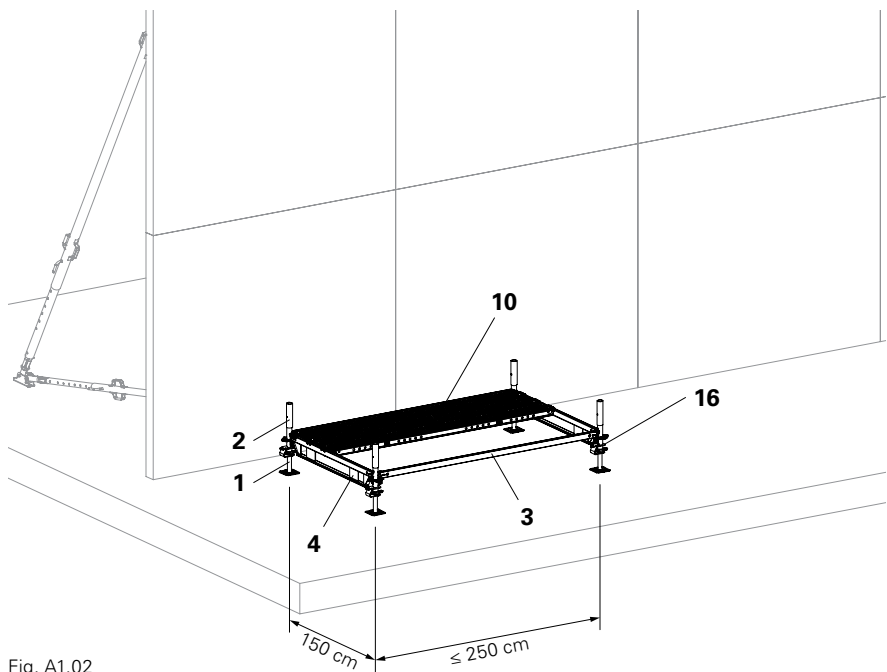
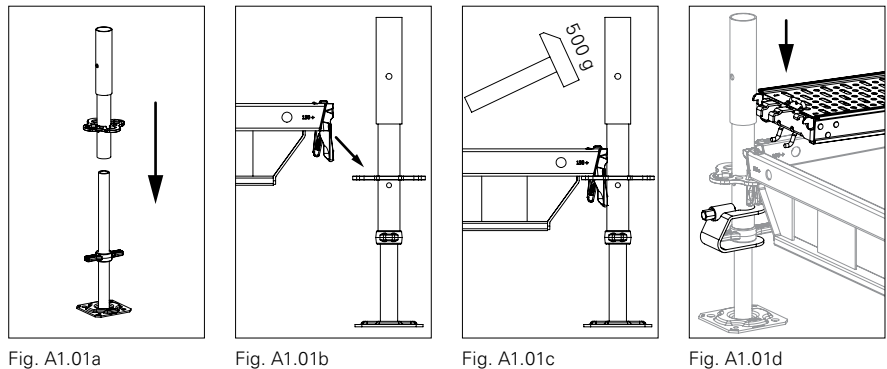

Fig. A1.02

Standards and Ledgers

Pos.	Component	Qty.
3	Ledger UH Plus	2x
3a	Ledger UH 75 Plus	4x
6	Standard UVR 300	4x
15	Ledger-to-Ledger Coupler UHA Half with Spigot	2x
17	Locking Pin Ø 48/57	4x

Assembly

1. Place Ledger-to-Ledger Coupler UHA (15) on the Ledger UHV 150 (4), do not yet secure wedges for alignment. (Fig. A1.03c)
2. Insert Standards UVR (6).
3. Connect Base Standards UVB (2) and Ledger-to-Ledger Couplers UHA (15) with Standards UVR (6) by means of Locking Pins (17). (Fig. A1.03c)
4. Attach Ledgers UH (3) and securely fix with wedges. (Fig. A1.03a)
5. Securely fix wedges for Ledger to Ledger UHA (15).
6. Attach Ledgers UH 75 (3a) and securely fix wedges.

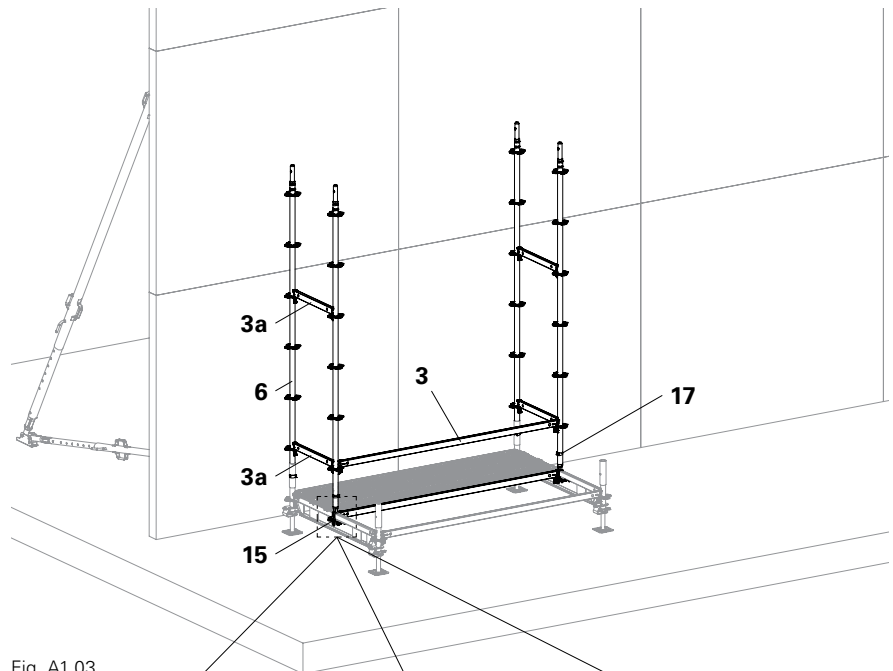

Fig. A1.03

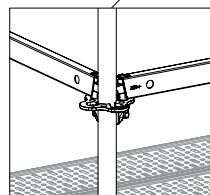

Fig. A1.03a

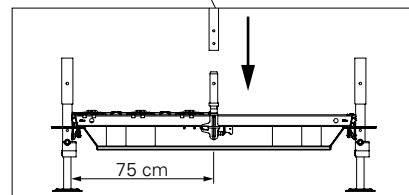

Fig. A1.03b

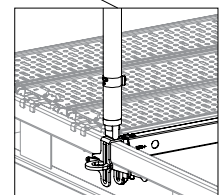

Fig. A1.03c

Attachment of base level



The base unit scaffolding can be extended by up to 2 additional bays.
Width of each bay: ≤ 300 cm.

Pos.	Component	Qty.
1	Adjustable Base Plate UJB	2x
2	Base Standard UVB 24	2x
3	Ledger UH Plus	2x
4	Ledger UHV 150 Plus	1x
16	Spindle Locking UJS	2x

Assembly

1. Place Adjustable Base Plates (1) in Base Standards (2) and attach Ledger UH (3) in the rosettes.
2. Mount on base level.
3. Horizontally align Addition by adjusting the Adjustable Base Plates (1).
4. Establish perpendicularity of the base.
5. Secure wedges on all Ledgers using a 500 g hammer.
6. Secure Adjustable Base Plate UJB with Spindle Locking UJS (16).
(Fig. A1.04)

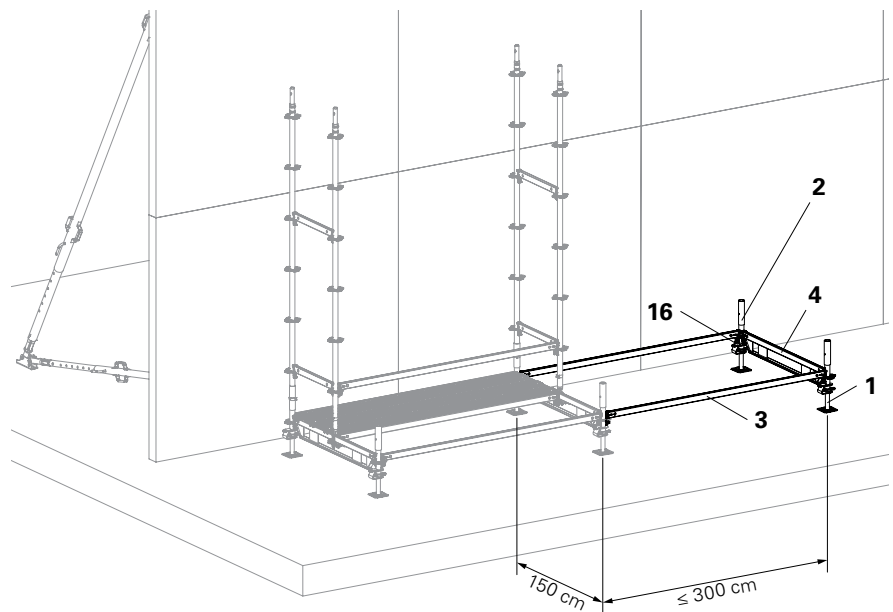

Fig. A1.04

Attachment of Standards and Ledgers

Pos.	Component	Qty.
3	Ledger UH Plus	2x
3a	Ledger UH 75 Plus	2x
6	Standard UVR 300	2x
15	Ledger-to-Ledger Coupler UHA Half with Spigot	1x
17	Locking Pin Ø 48/57	2x

Assembly

1. Place Ledger-to-Ledger Coupler UHA (15) on Ledger UHV (4), do not yet secure wedges for alignment.
2. Insert Standards UVR (6).
3. Connect Base Standards UVB (2) and Ledger-to-Ledger Coupler UHA (15) with Standards UVR (6) by means of Locking Pins (17).
4. Attach Ledgers UH (3) and securely fix wedges.
5. Attach Ledgers UH 75 (3a) and securely fix wedges.
(Fig. A1.05)

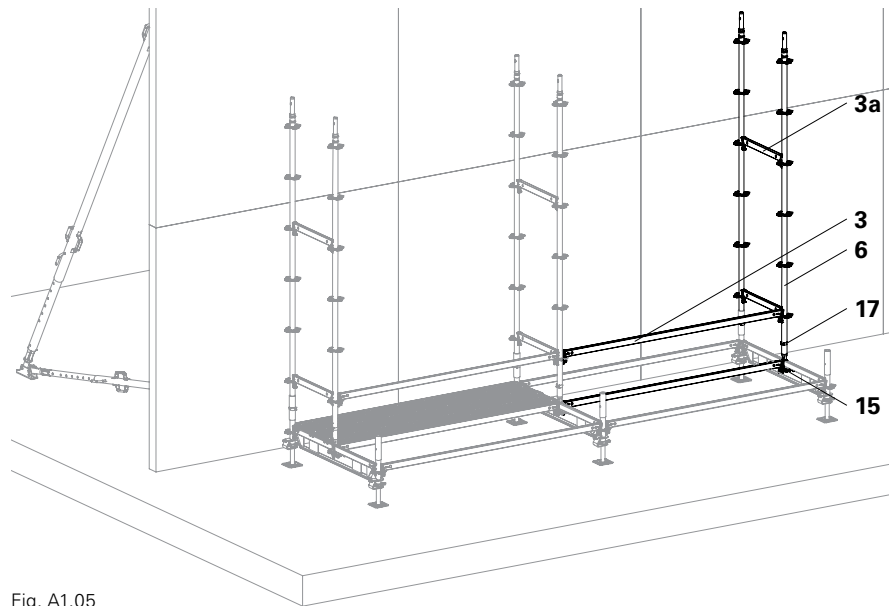

Fig. A1.05

Access decks, decking and guardrails



Warning

Risk of falling!

⇒ Use PPE to prevent falling.

Pos.	Component	Qty.
3	Ledger UH Plus	8x
3a	Ledger UH 75 Plus	4x
7	Access Deck UAL-3	1x
8	Ladder Flex UEL with Hook	1x
9	Toeboard Wood UPF	2x
10	Steel Deck UDG	3x

Assembly

1. Attach Access Deck UAL-3 (7).
Standing position: below.
2. Insert Steel Deck UDG (10). Standing position: below.
→ Lift-off prevention devices drop under the UH Ledger (3a) and secure the decking.
3. Attach Ladder Flex UEL (8).
4. From the ladder:
attach Ledger UH (3) to the outer side.
From the decking:
mount Ledgers as guardrails all the way round from outside to inside.
Securely fix the wedges.
(Fig. A1.06)
5. Attach Toeboard UPF (9) on the outside to the Standards. (Fig. A1.06a)

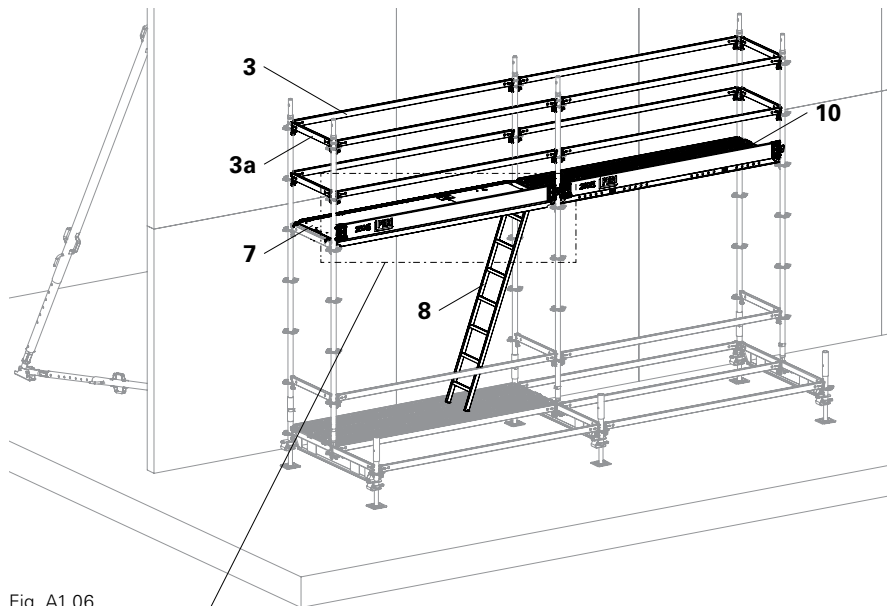

Fig. A1.06

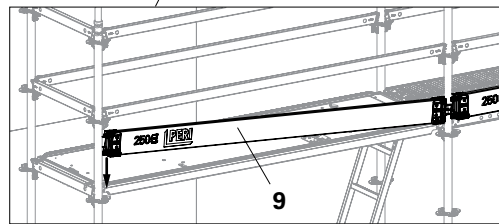

Fig. A1.06a

Stability



Warning

Risk of falling!

⇒ During the assembly work, keep the hatch closed.

Pos.	Component	Qty.
11	Ledger Brace UBL	2x
12	Node Brace UBK	3x

Assembly

1. Insert Ledger Brace UBL (11) with the lower finger in the bottom Ledger UH (3). (Fig. A1.07c + A1.07d)
2. Insert the gravity pin into the holes of the top Ledger UH (3), turn pin to secure. (Fig. A1.07e + A1.07f)
3. Mount Node Brace UBK (12) at top to Standard UVR (6). (Fig. A1.07a + A1.07b)
4. Mount Node Brace UBK (12) below on the Base Standard UVB (2).

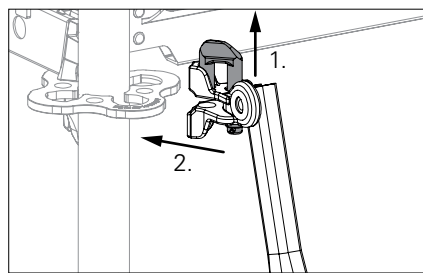

Fig. A1.07a

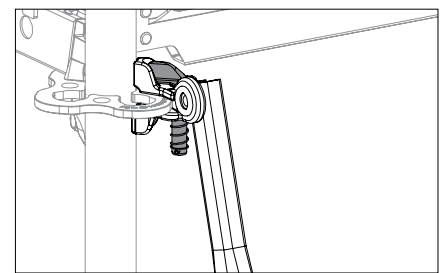

Fig. A1.07b

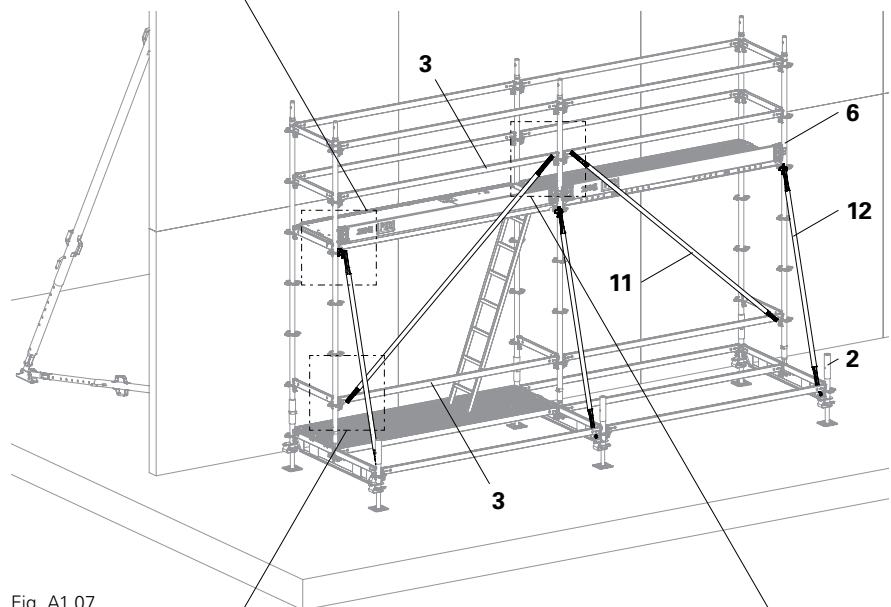

Fig. A1.07

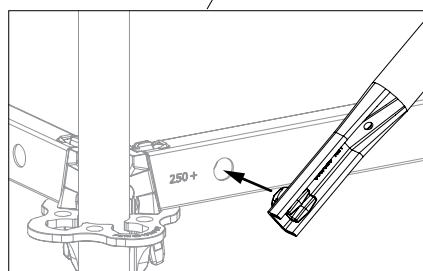

Fig. A1.07c

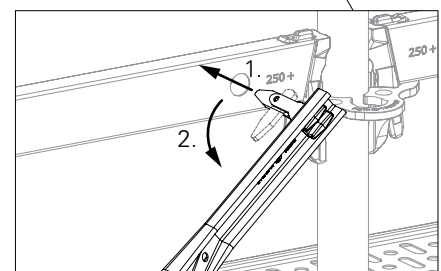

Fig. A1.07e

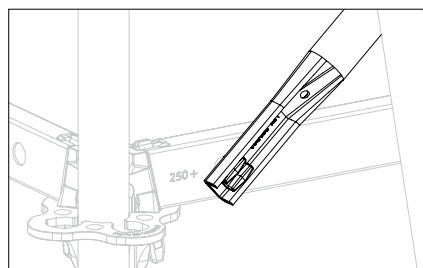

Fig. A1.07d

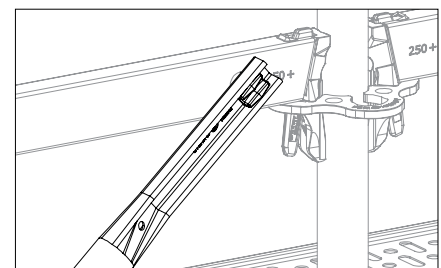

Fig. A1.07f

Standards and Ledgers

Pos.	Component	Qty.
3a	Ledger UH 75 Plus	3x
6a	Standard UVR 200	6x
17	Locking Pin Ø 48/57	6x

Assembly

1. Insert Standards UVR (6a). Align legs in accordance with the holes.
2. Tightly connect Standards (6) (6a) by means of Locking Pins (17).
3. Attach Ledgers UH 75 (3a) and securely fix wedges.
(Fig. A2.01)

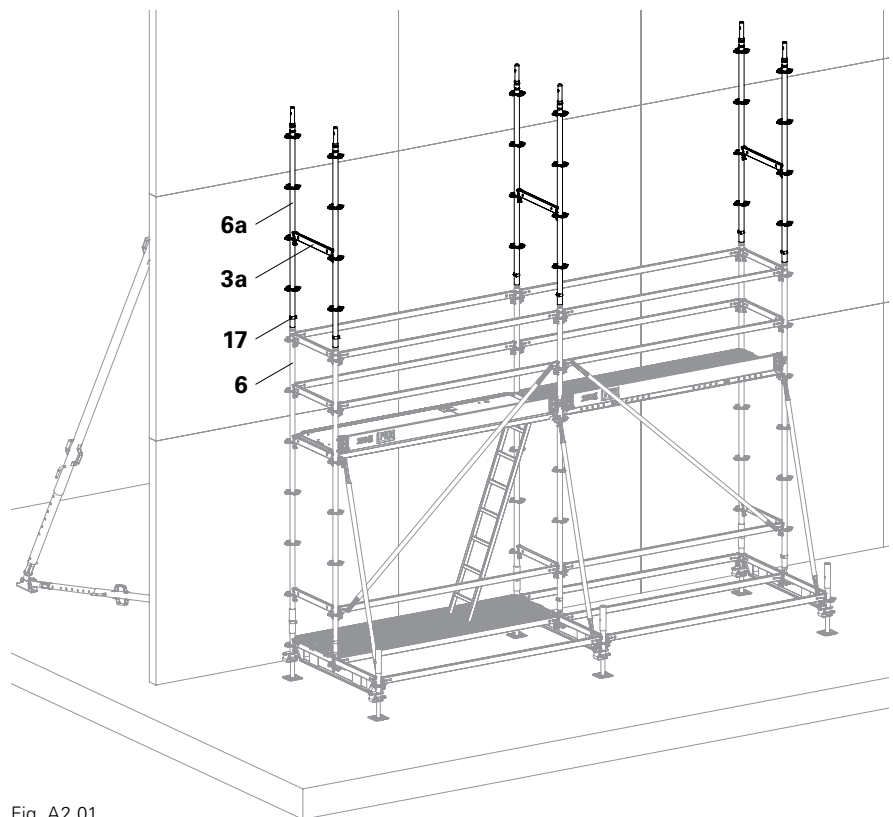

Fig. A2.01

Access decks, decking and guardrails



Warning

Risk of falling!

⇒ Use PPE to prevent falling.

Pos.	Component	Qty.
3	Ledger UH Plus	8x
3a	Ledger UH 75 Plus	4x
7	Access Deck UAL-3	1x
8	Ladder Flex UEL	1x
9	Toeboard Wood UPF	2x
10	Steel Deck UDG	3x
11	Ledger Brace UBL	1x

Assembly

1. Mount Access Deck UAL (7) and Steel Deck UDG (10) from below.
→ Lift-off prevention devices drop under the UH Ledger (3a) and secure the decking.
2. Attach Ladder Flex UEL (8).
3. From the ladder or a safe working position:
attach Ledger UH 75 (3a) and UH (3) to the outer side.
From the decking:
mount ledgers as guardrails all the way round from outside to inside.
Securely fix the wedges.
4. Attach Toeboard UPF (9) on the outside to the Standards.
5. Insert Ledger Brace UBL (11) with the lower finger into the bottom Ledger UH.
Insert the gravity pin into the holes of the top ledger, turn pin to secure.
(Fig. A2.02)

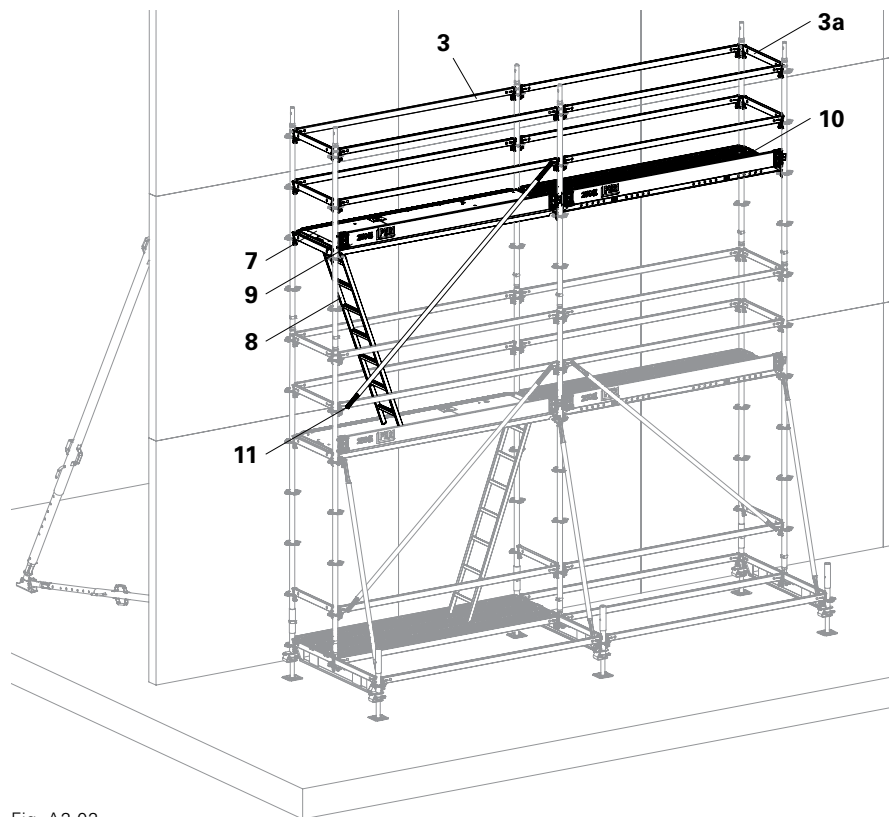

Fig. A2.02

Additional levels

The number of extensions is limited to a maximum of 3 floors.
Max. standing height ≤ 660 cm.



Warning

Risk of falling!

⇒ During work operations, keep the hatch closed.

Assembly

Assembly process is repeated according to the steps on page 20 and 21.

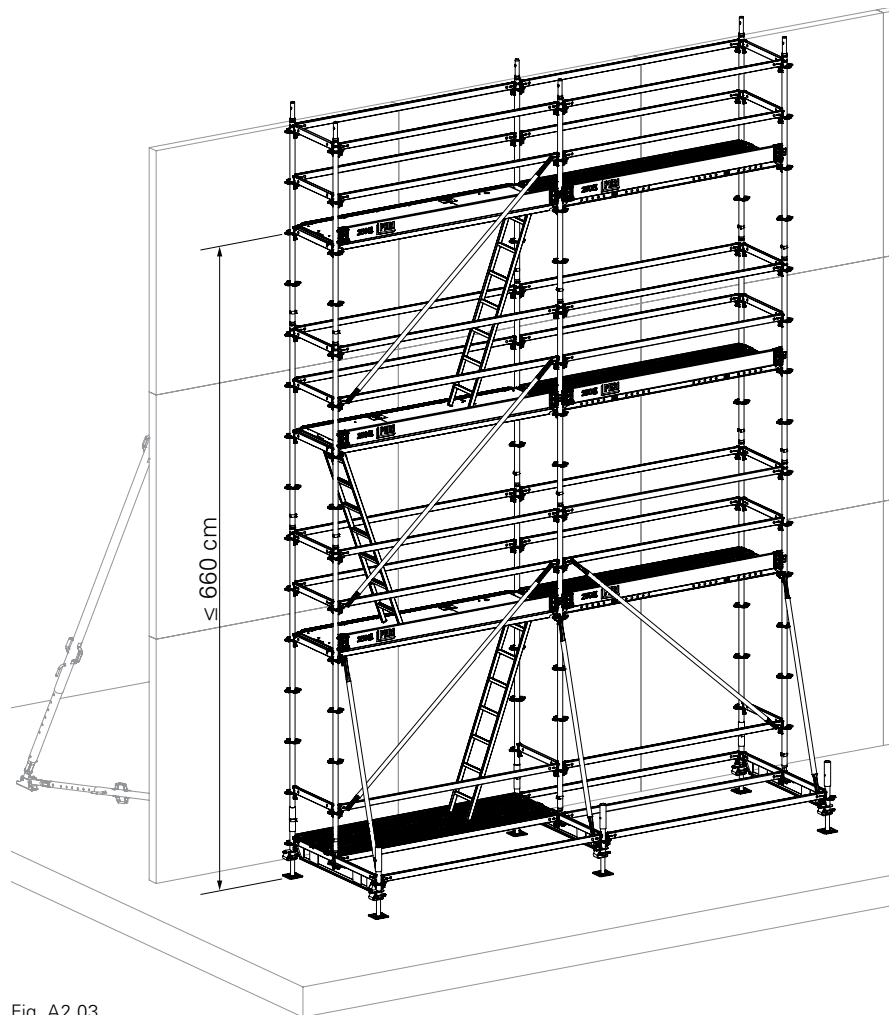

Fig. A2.03



Danger

Risk of injury!

⇒ The Adjustable Base Plate UJS (1) must be secured to prevent falling out. (Fig. A3.01b)



Compression forces to the wall or formwork are to be verified on site by the contractor!

With standing heights of 424 cm and more, pressure-resistant ties are to be mounted on all standards – directly under the highest deck level – and positioned up against the wall or formwork.

Pos.	Component	Qty.
13	Steel Scaffold Tube Ø 48.3 x 3.2	3x
19	Standard Coupling NK 48/48	6x

Assembly

Directly under highest deck level.

1. Securely fix the scaffold tube (13) to the Standard UVR using standard couplers (19).
2. Adjust distance of scaffold tube from the wall.
(Fig. A3.01a)



PERI recommends inserting an Adjustable Base Plate UJS (1) into the scaffold tube if the distance to the wall must be adjusted more often. Secure Adjustable Base Plates against falling out. (Fig. A3.01b)

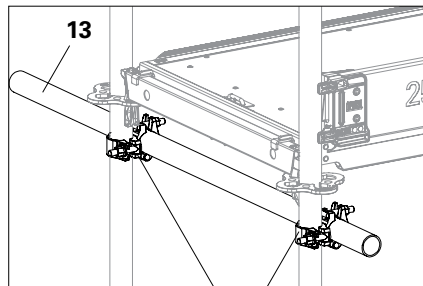

Fig. A3.01a

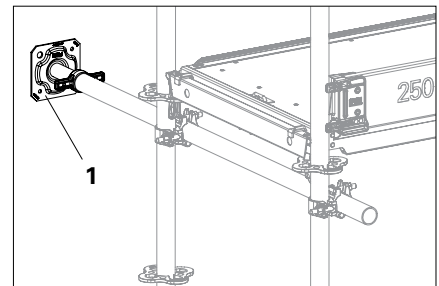

Fig. A3.01b

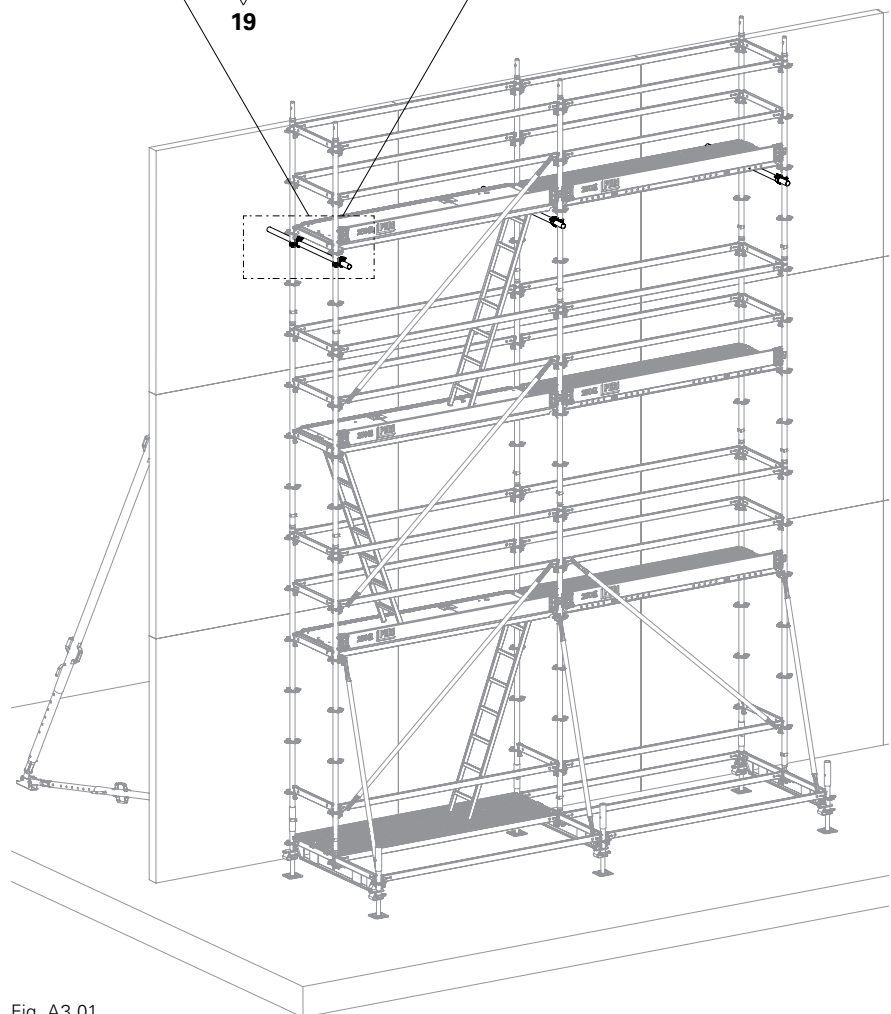

Fig. A3.01

Recommendation



Warning

Risk of falling!

⇒ During work operations, keep the hatch closed.

⇒ Use PPE to prevent falling.



Following the completion of his own risk assessment, the scaffold contractor can also determine other dismantling options.

Dismantling takes place from top to bottom, with personnel always in a safe position.

Dismantling is carried out whilst progressively working back to the access ladder bay.

Dismantling procedure

1. From a position on the decking level:

- Ledger UH 75 opposite the hatch (Fig. A4.01a)
- Ledger UH on the inside and Toeboards (Fig. A4.01b)
- Ledger UH on the outside, from a safe position (Fig. A4.01c)
- Ledger Brace UBL - top - bottom
- Ledger UH on the inside, from a safe position (Fig. A4.01d)

1.
1.1

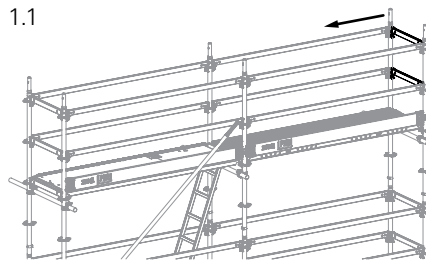

Fig. A4.01a

1.2

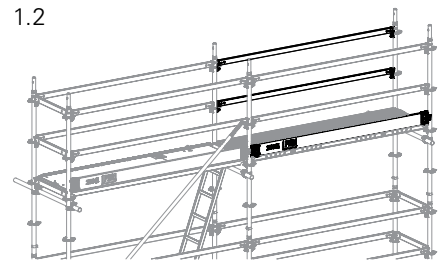

Fig. A4.01b

1.3

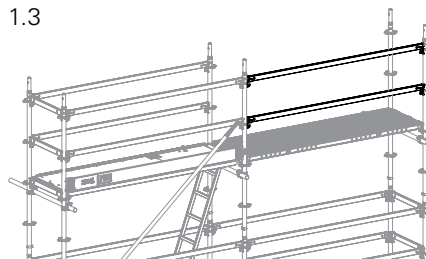

Fig. A4.01c

1.4

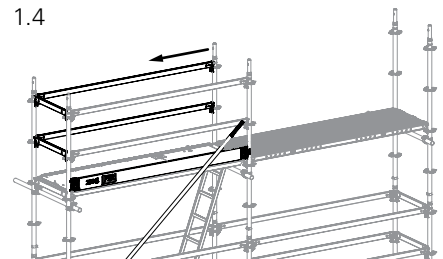

Fig. A4.01d

2. From a position on the ladder:

- Ledger UH on the outside
- Close hatch from below (Fig. A4.02)

2.

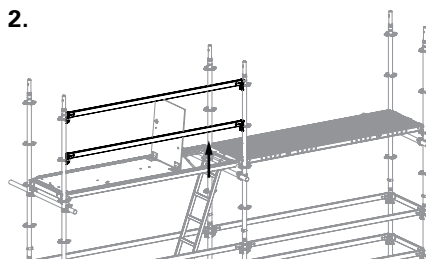

Fig. A4.02

3. From a position on the next level below:

- Ladder, access deck and top Decks UDG (Fig. A4.03a)
- Pressure-resistant ties
- Ledger UH 75
- Locking Pins \varnothing 48/57
- Standards UVR (Fig. A4.03b)
- Continuously dismantle reinforcement scaffold in this sequence

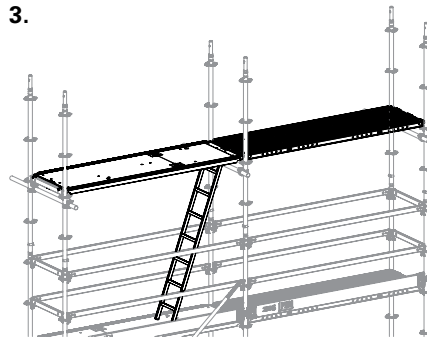

Fig. A4.03a

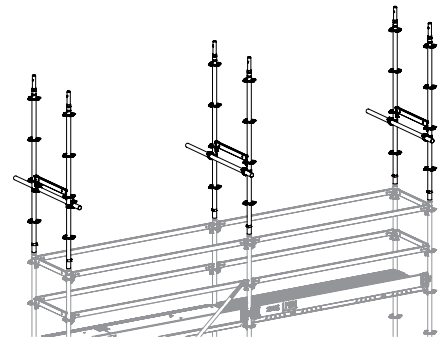

Fig. A4.03b

4. Dismantling the base level:

Dismantling to take place in this order:

- Ledger Braces UBL and Toeboards
- Ledger UH 75 and Ledger UH
- Ladder, access deck and Decks UDG
- Node Brace UBK (Fig. A4.04a)
- Ledger UH 75 and Ledger UH
- Locking Pins \varnothing 48/57
- Standards UVR
- Ledger-to-Ledger Coupler UHA Half with Spigot
- Ledger UHV 150 Plus
- Spindle Locking UJS
- Base Standard UVB (Fig. A4.04b)

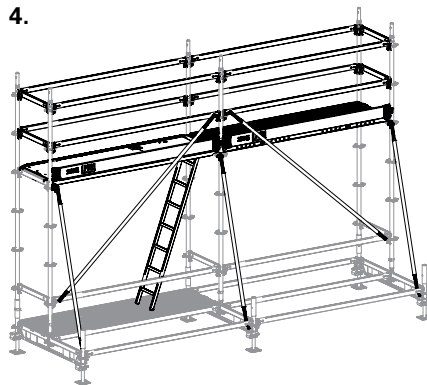

Fig. A4.04a

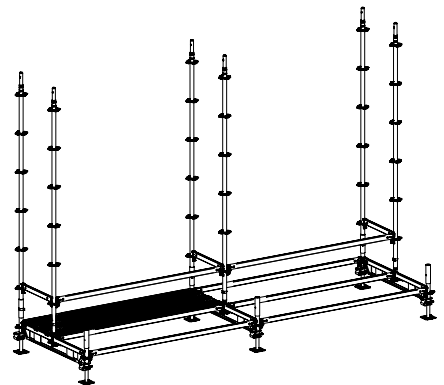

Fig. A4.04b

B1 Assembling the base with Ledger UHV 250

Base level



- Assembly of the reinforcement scaffold must always take place in front of a wall or secure formwork units!
- The surface used must have sufficient load-bearing capacity.

Pos.	Component	Qty.
1	Adjustable Base Plate UJB	4x
2	Base Standard UVB 24	4x
3	Ledger UH Plus	2x
5	Ledger UHV 250 Plus	2x
10	Steel Deck UDG	3x
16	Spindle Locking UJS	4x

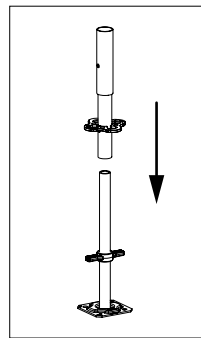

Fig. B1.01a

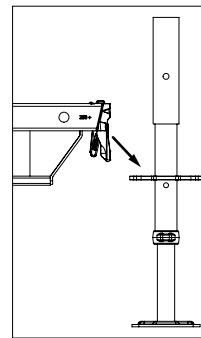

Fig. B1.01b

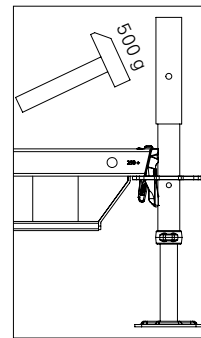

Fig. B1.01c

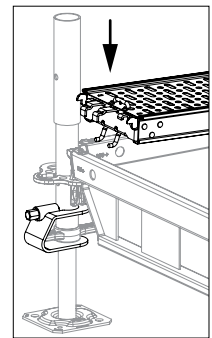

Fig. B1.01d

Assembly

1. Assemble frame.
2. Horizontally align frame by adjusting the Adjustable Base Plates.
Max. spindle adjustment range for
 - Base Plate UJB 38-50/30: ≤ 26 cm
 - Base Plate UJB 38-80/55: ≤ 39 cm
3. Establish perpendicularity of the base.
4. Secure wedges on all ledgers using a 500 g hammer.
(Fig. B1.01a + B1.01b + B1.01c)
5. Insert Steel Deck UDG (10).
→ Lift-off prevention devices drop under the UH Ledger (5) and secure the decking.
6. Secure Adjustable Base Plate UJB with Spindle Locking UJS (16).
(Fig. B1.01d)

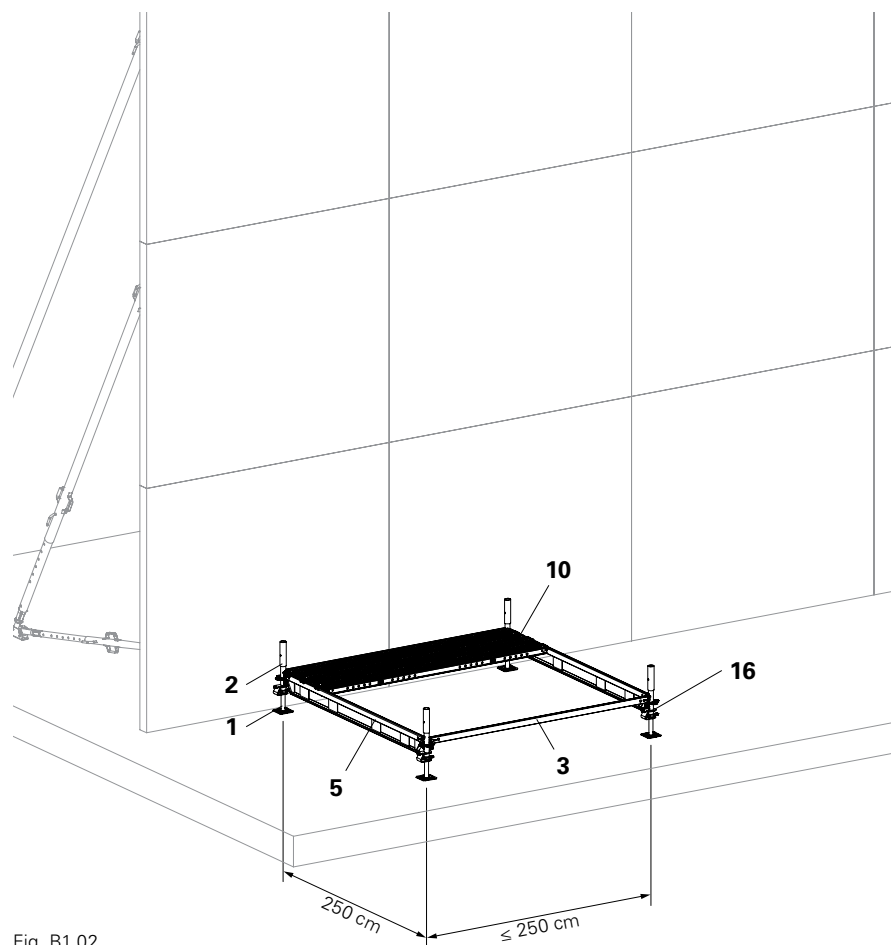

Fig. B1.02

Standards and Ledgers

Pos.	Component	Qty.
3	Ledger UH Plus	2x
3a	Ledger UH 75 Plus	4x
6	Standard UVR 300	4x
15	Ledger-to-Ledger Coupler UHA Half with Spigot	2x
17	Locking Pin Ø 48/57	4x

Assembly

1. Place Ledger-to-Ledger Coupler UHA (15) on the Ledger UHV 250 (5), do not yet secure wedges for alignment. (Fig. B1.03c)
2. Insert Standards UVR (6).
3. Connect Base Standards UVB (2) and Ledger-to-Ledger Coupler UHA (15) with Standards UVR (6) by means of Locking Pins (17). (Fig. B1.03c)
4. Attach Ledgers UH (3) and securely fix with wedges. (Fig. B1.03a)
5. Securely fix wedges for Ledger-to-Ledger UHA (15).
6. Attach Ledgers UH 75 (3a) and securely fix wedges.

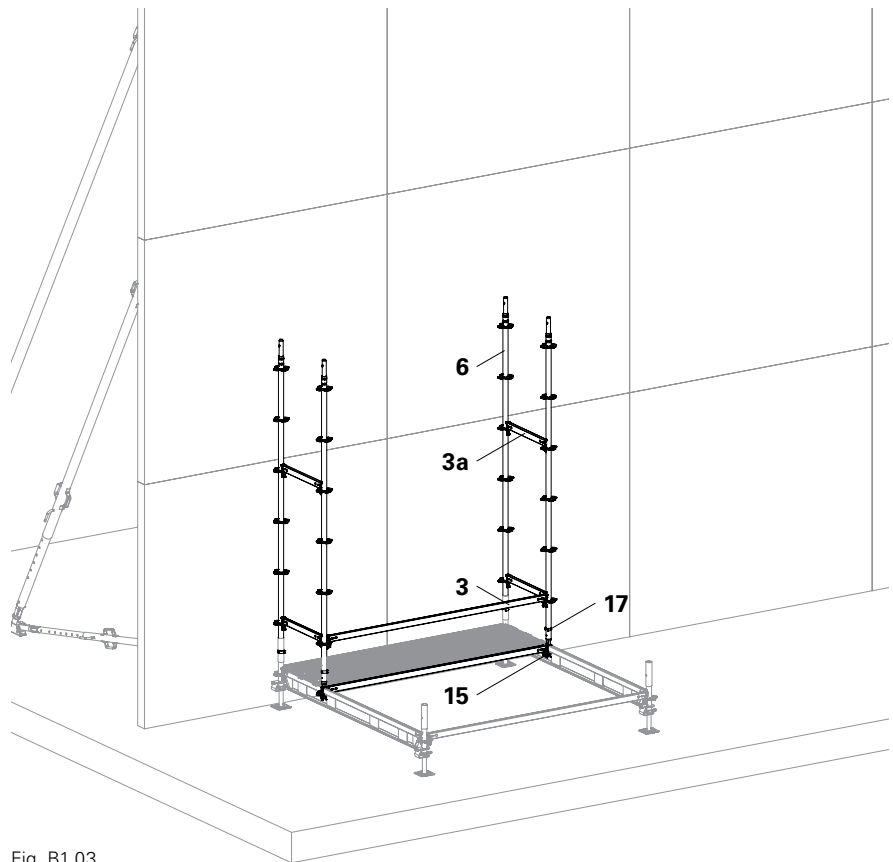

Fig. B1.03

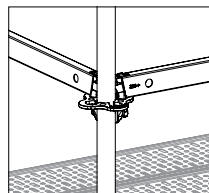

Fig. B1.03a

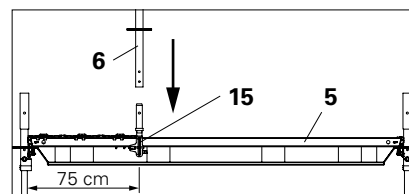

Fig. B1.03b

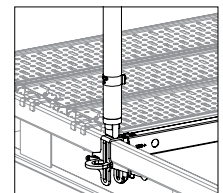

Fig. B1.03c

Attachment of base level

The base unit scaffolding can be extended by up to 2 additional bays.
Width of each bay: ≤ 300 cm.

Pos.	Component	Qty.
1	Adjustable Base Plate UJB	2x
2	Base Standard UVB 24	2x
3	Ledger UH Plus	2x
5	Ledger Heavy Duty UHV 250 Plus	1x
16	Spindle Locking UJS	2x

Assembly

- Place Adjustable Base Plates (1) in Base Standards (2) and attach Ledger UH (3) in the rosettes.
- Mount on base level.
- Horizontally align Addition by adjusting the Adjustable Base Plates (1).
- Establish perpendicularity of the base.
- Secure wedges on all Ledgers using a 500 g hammer.
- Secure Adjustable Base Plate UJB with Spindle Locking UJS (16).
(Fig. B1.04)

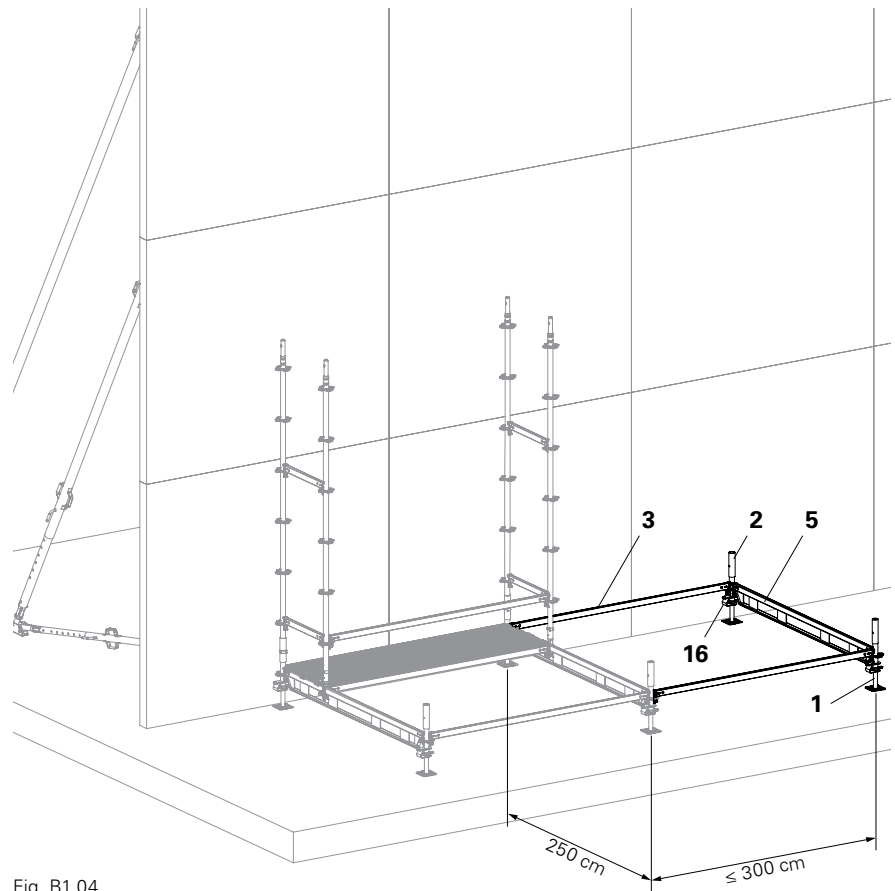

Fig. B1.04

Attachment of Standards and Ledgers

Pos.	Component	Qty.
3	Ledger UH Plus	2x
3a	Ledger UH 75 Plus	2x
6	Standard UVR 300	2x
15	Ledger-to-Ledger Coupler UHA 1x	1x
17	Locking Pin \varnothing 48/57	2x

Assembly

1. Place Ledger-to-Ledger Coupler UHA (15) on Ledger UHV (5), do not yet secure wedges for alignment.
2. Insert Standards UVR (6).
3. Connect Base Standard UVB (2) and Ledger-to-Ledger Coupler UHA (15) with Standard UVR (6) by means of Locking Pins (17).
4. Attach Ledgers UH (3) and securely fix with wedges.
5. Attach Ledgers UH 75 (3a) and securely fix wedges. (Fig. B1.05)

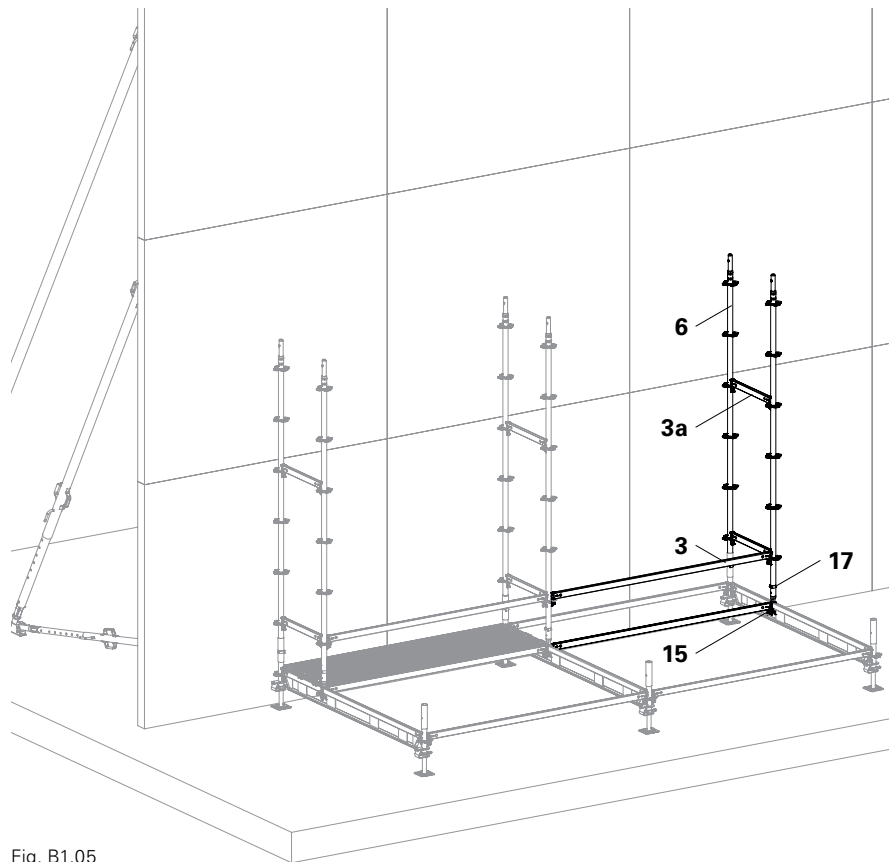

Fig. B1.05

Access decks, decking and guardrails



Warning

Risk of falling!

⇒ Use PPE to prevent falling.

⇒ During work operations, keep the hatch closed.

Pos.	Component	Qty.
3	Ledger UH Plus	8x
3a	Ledger UH 75 Plus	4x
7	Access Deck UAL-3	1x
8	Ladder Flex UEL with Hook	1x
9	Toeboard Wood UPF	2x
10	Steel Deck UDG	3x
11	Ledger Brace UBL	2x

Assembly

1. Attach Access Deck UAL-3 (7).
Standing position: below.
2. Insert Steel Deck UDG (10). Standing position: below.
3. Attach Ladder Flex UEL (8).
4. From the ladder:
attach Ledger UH (3) to the outer side.
From the decking:
mount Ledgers as guardrails all the way round from outside to inside.
Securely fix the wedges.
(Fig. B1.06)
5. Attach Toeboard UPF (9) on the outside to the Standards. (Fig. B1.06a)
6. Insert Ledger Brace UBL (11) with the lower finger in the bottom Ledger UH (3). (Fig. B1.06b + B1.06c)
7. Insert the gravity pin into the holes of the top Ledger UH (3), turn pin to secure. (Fig. B1.06d + B1.06e)

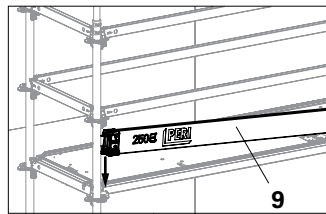

Fig. B1.06a

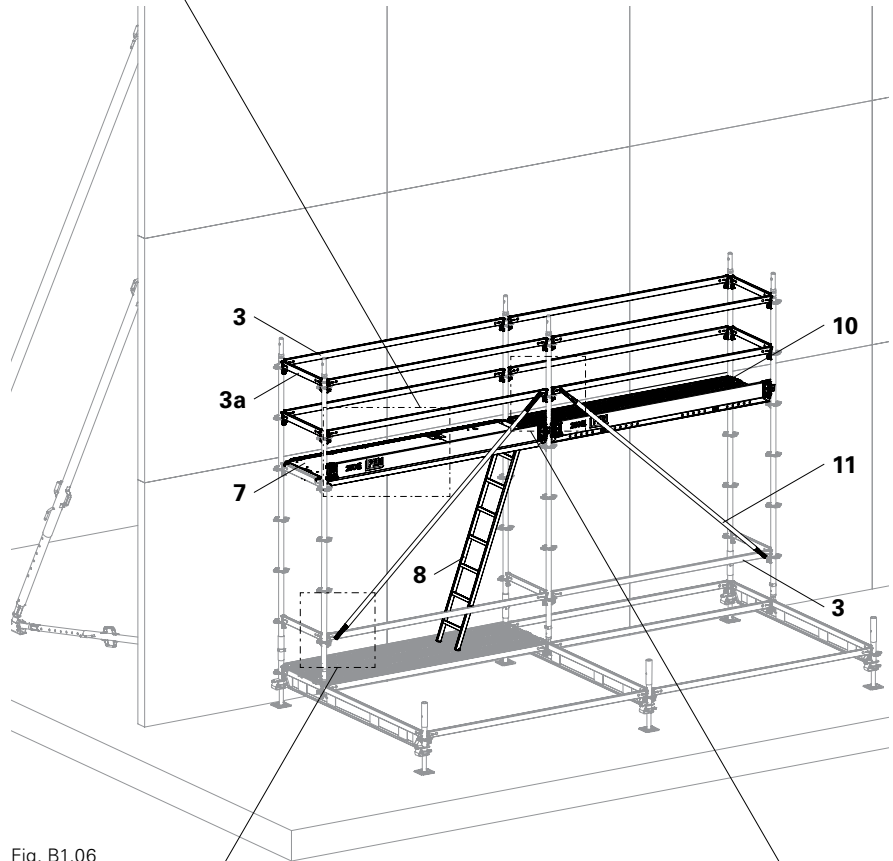

Fig. B1.06

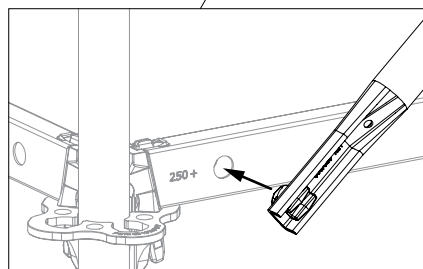

Fig. B1.06b

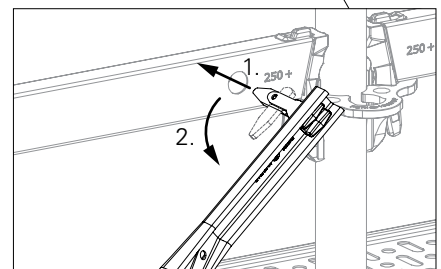

Fig. B1.06d

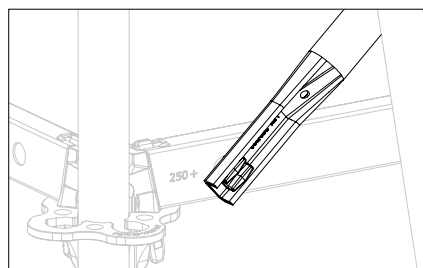

Fig. B1.06c

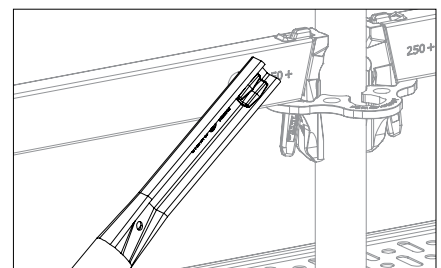

Fig. B1.06e

Standards and Ledgers

Pos.	Component	Qty.
3a	Ledger UH 75 Plus	3x
6a	Standard UVR 200	6x
17	Locking Pin \varnothing 48/57	6x

Assembly

1. Insert Standards UVR (6a). Align legs in accordance with the holes.
2. Tightly connect Standards (6) (6a) by means of Locking Pins (17).
3. Attach Ledgers UH 75 (3a) and securely fix wedges.
(Fig. B2.01)

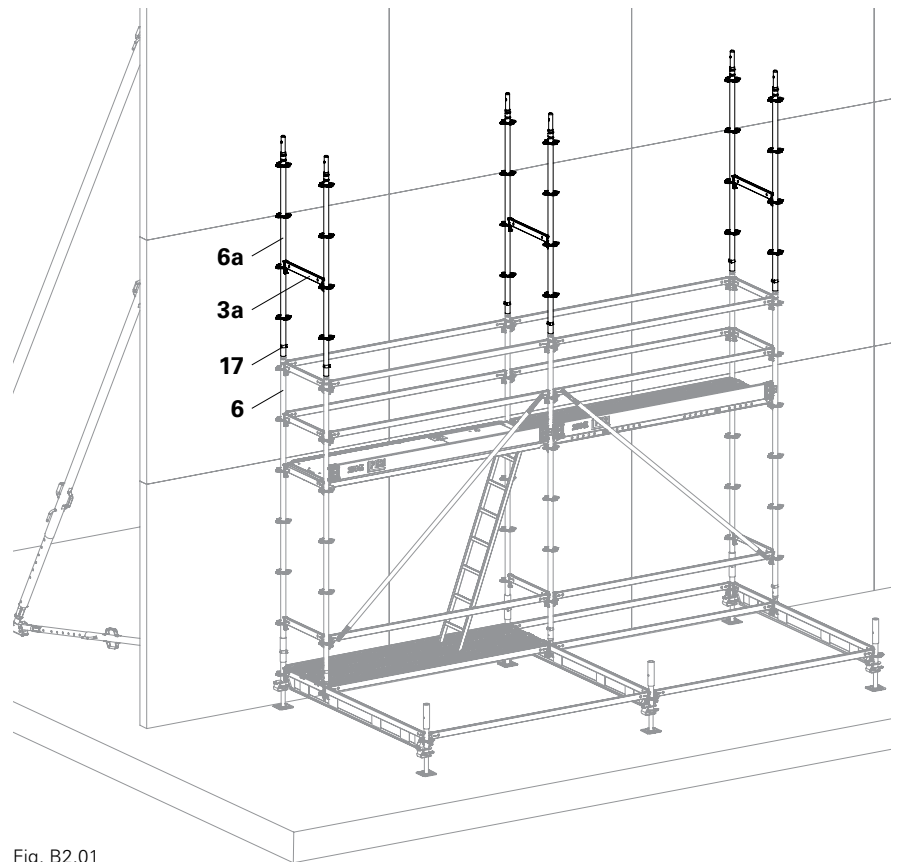

Fig. B2.01

Access decks, decking and guardrails



Warning

Risk of falling!

⇒ During work operations, keep the hatch closed.

Pos.	Component	Qty.
3	Ledger UH Plus	8x
3a	Ledger UH 75 Plus	4x
7	Access Deck UAL-3	1x
8	Ladder Flex UEL with Hook	1x
9	Toeboard Wood UPF	2x
10	Steel Deck UDG	3x
11	Ledger Brace UBL	1x

Assembly

1. Attach Access Deck UAL-3 (7).
Standing position: below.
2. Insert Steel Deck UDG (10). Standing position: below.
3. Attach Ladder Flex UEL (8).
4. From the ladder or a safe working position:
attach Ledger UH (3) to the outer side.
From the decking:
mount Ledgers as guardrails all the way round from outside to inside.
Securely fix the wedges.
5. Attach Toeboard UPF (9) on the outside to the Standards.
6. Insert Ledger Brace UBL (11) with the finger in the lower bottom Ledger UH (3). Insert the gravity pin into the holes of the top Ledger UH (3), turn pin to secure.
(Fig. B2.02)

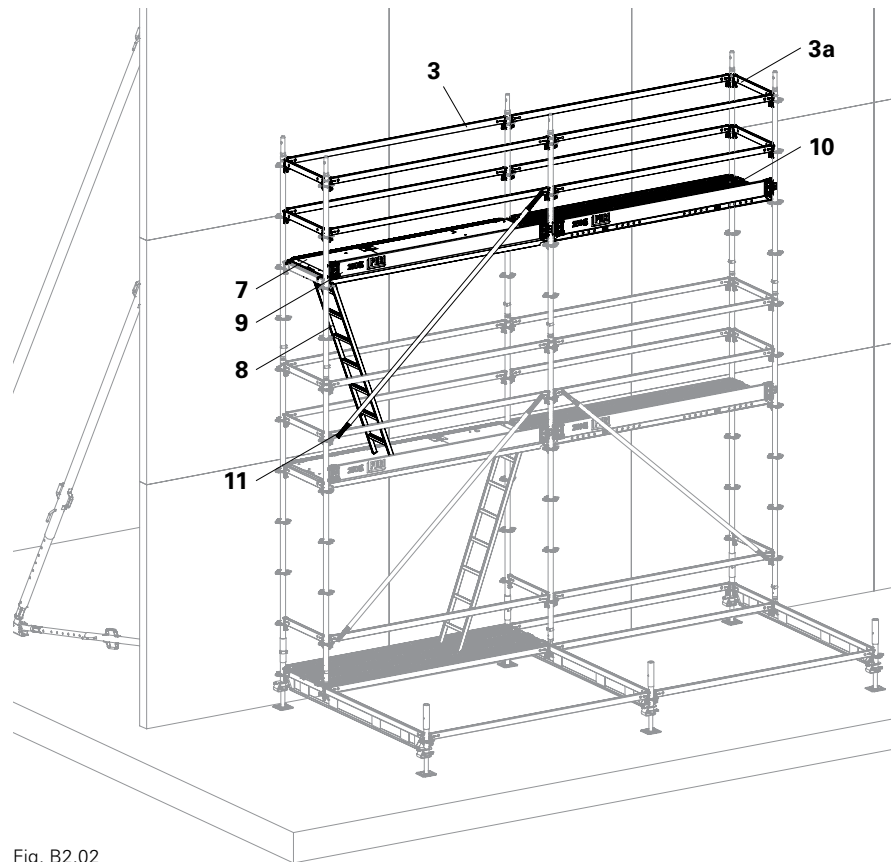

Fig. B2.02

Stability

Pos.	Component	Qty.
13	Steel Scaffold Tube \varnothing 48.3 x 3.2 3x	
14a	Swivel Coupling DK 48/48	3x
14b	Swivel Coupling DK 48/60	3x

Assembly

Attach scaffold tubes (13) at the top to the outside Standard with Swivel Coupling 48/48 (14a) and at the bottom to the Base Standard using Swivel Coupling 48/60 (14b).
(Fig. B2.03)

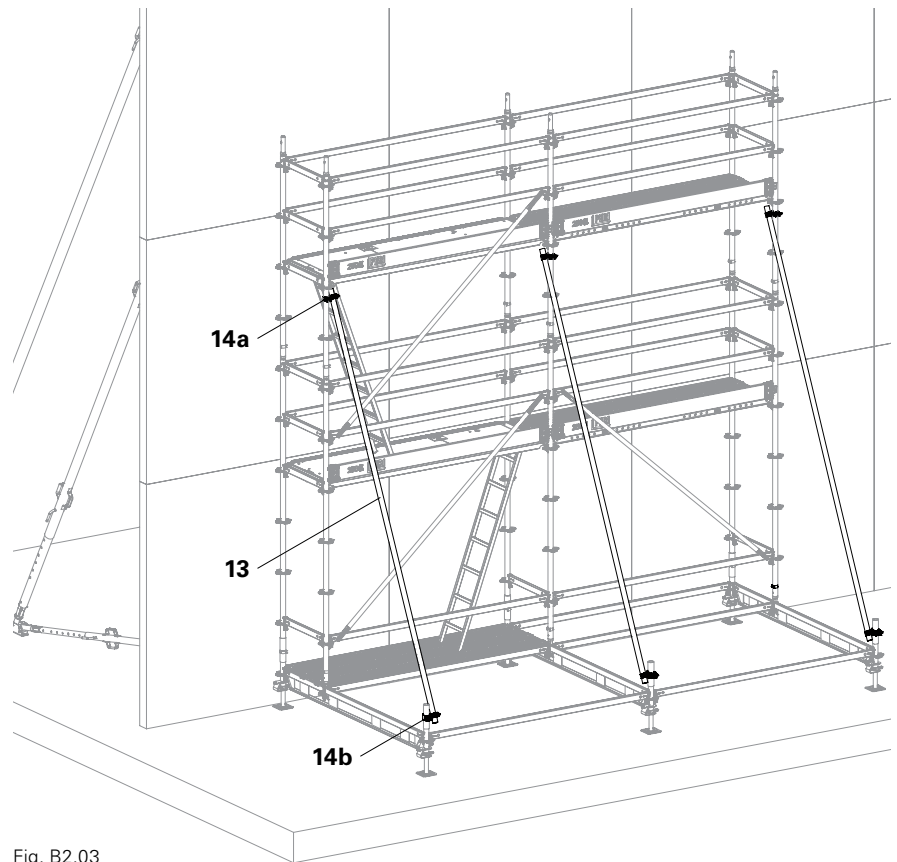

Fig. B2.03

Additional levels



Warning

Risk of falling!

⇒ During the assembly work, keep the hatch closed!

The number of additional levels is limited to a maximum of 5 floors.

Max. standing height ≤ 1060 cm.

Assembly

Assembly process is repeated according to the steps on page 31 and 32.

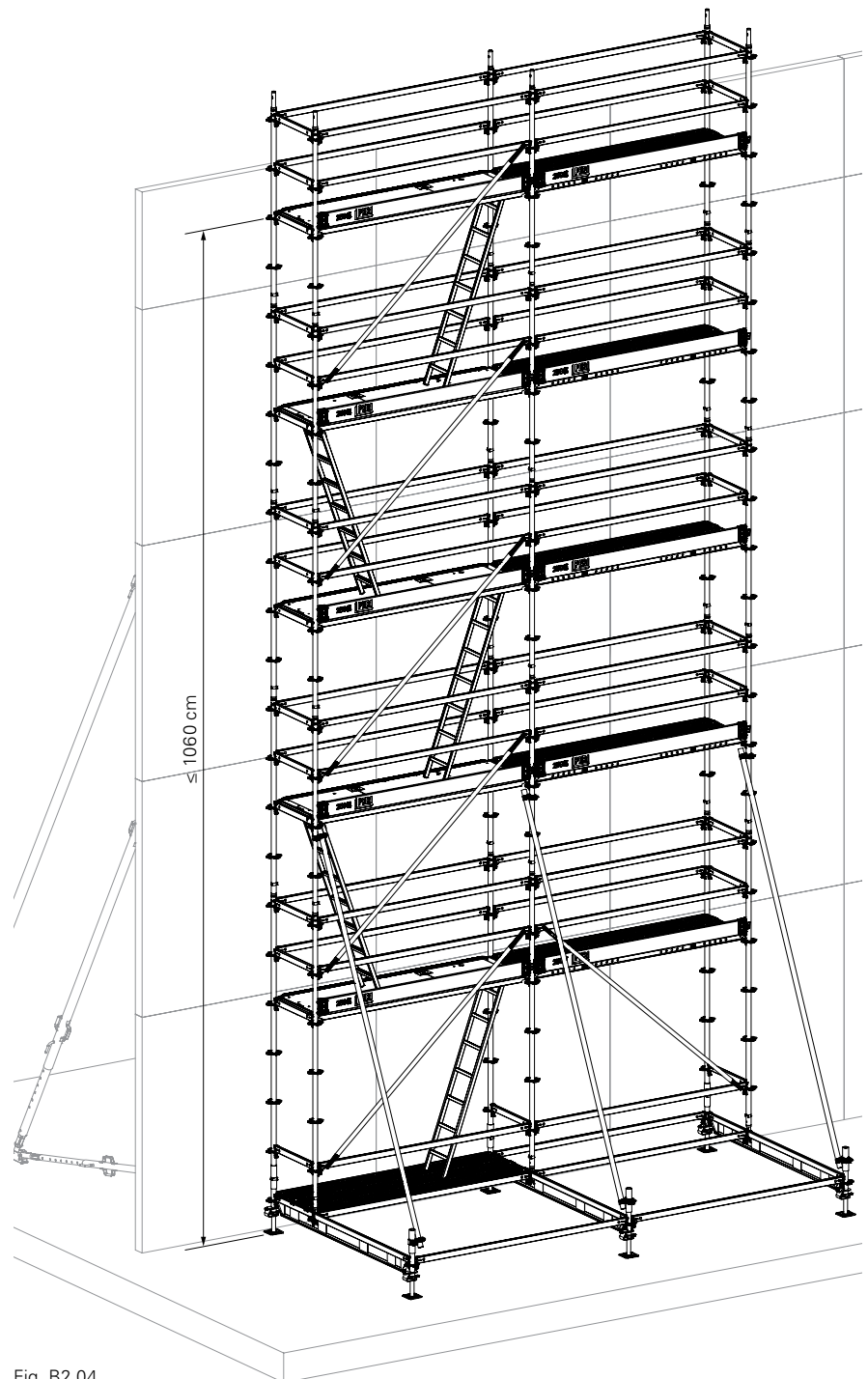

Fig. B2.04



Danger

Risk of injury!

⇒ The Adjustable Base Plate UJS (1) must be secured to prevent falling out. (Fig. A3.01b)



Compression forces to the wall or formwork are to be verified on site by the contractor!

With standing heights of 424 cm and more, pressure-resistant ties are to be mounted on all Standards – directly under the highest deck level – and positioned up against the wall or formwork.

Pos.	Component	Qty.
13	Steel Scaffold Tube Ø 48.3 x 3.2 3x	
19	Standard Coupling NK 48/48 6x	

Assembly

Directly under highest deck level.

1. Securely fix the scaffold tube (13) to the Standard UVR using Standard Couplers (19).
2. Adjust distance of scaffold tube from the wall.



PERI recommends inserting an Adjustable Base Plate UJS (1) into the scaffolding tube if the distance to the wall has to be adjusted more often. Secure Adjustable Base Plates against falling out. (Fig. B3.01b)

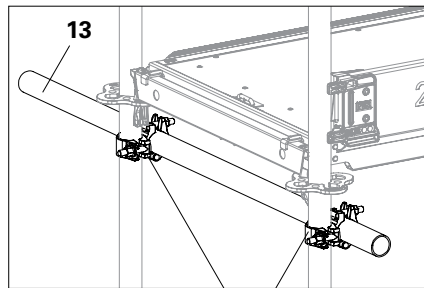

Fig. B3.01a

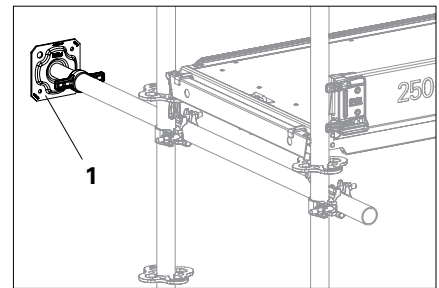

Fig. B3.01b

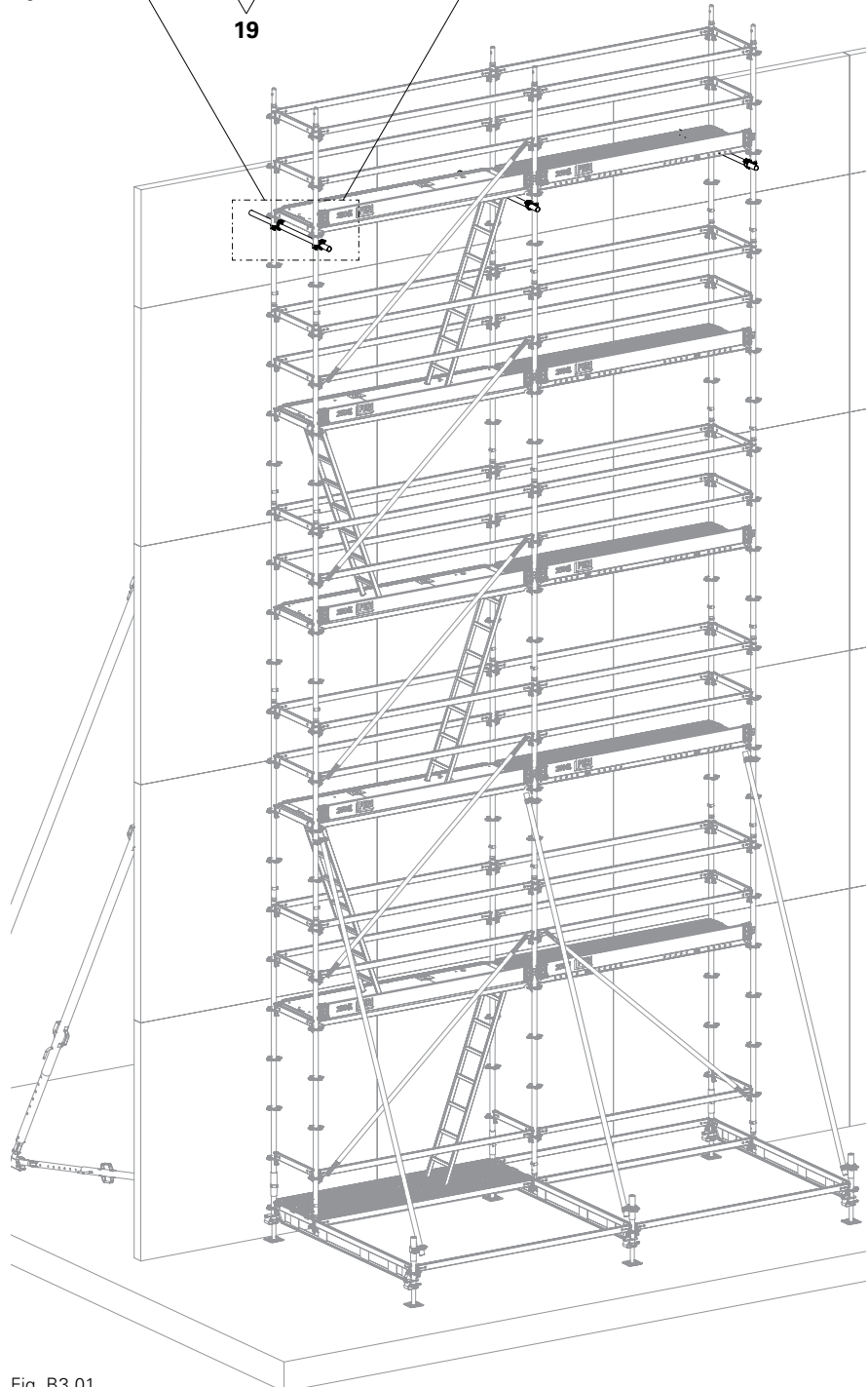

Fig. B3.01

Recommendation



Warning

Risk of falling!

⇒ During work operations, keep the hatch closed.

⇒ Use PPE to prevent falling.



Following the completion of his own risk assessment, the scaffold contractor can also determine other dismantling options.

Dismantling takes place from top to bottom, with personnel always in a safe position.

Dismantling is carried out whilst progressively working back to the access ladder bay.

Dismantling procedure

1. From a position on the decking level:

- Ledger UH 75 opposite the access ladder (Fig. A4.01a)
- Ledger UH on the inside and Toeboards (Fig. A4.01b)
- Ledger UH on the outside, from a safe position (Fig. A4.01c)
- Ledger Brace UBL - top - bottom
- Ledger UH on the inside, from a safe position (Fig. A4.01d)

1.
1.1

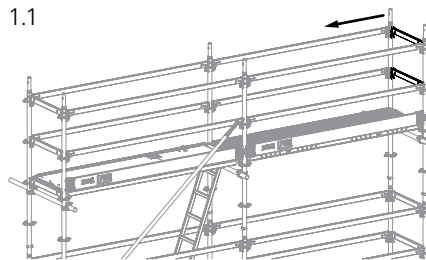

Fig. B4.01a

1.2

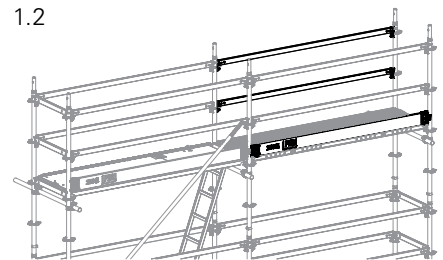

Fig. B4.01b

1.3

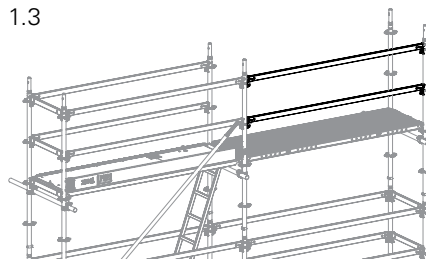

Fig. B4.01c

1.4

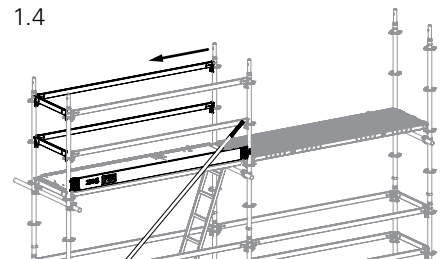

Fig. B4.01d

2. From a position on the ladder:

- Ledger UH outside
- Close hatch from below (Fig. A4.02)

2.

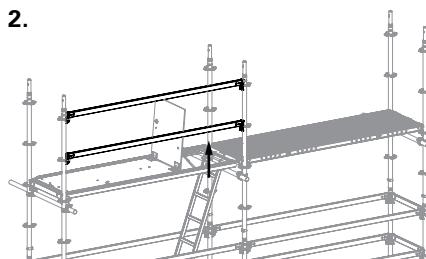

Fig. B4.02

3. From a position on the next level below:

- Ladder, access deck and top Deck UDG (Fig. A4.03a)
- Pressure-resistant ties
- Ledger UH 75
- Locking Pins \varnothing 48/57
- Standards UVR (Fig. A4.03b)
- Continuously dismantle reinforcement scaffold in this sequence

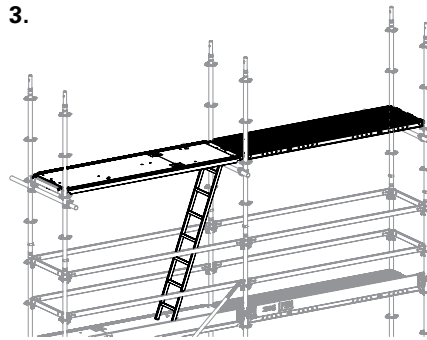

Fig. B4.03a

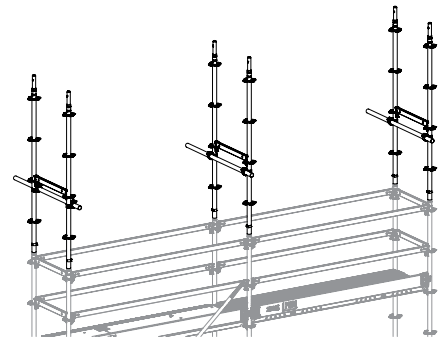

Fig. B4.03b

4. Dismantling the base level

Dismantling to take place in this order:

- Ledger Braces UBL and Toeboards
- Ledger UH 75 and Ledger UH
- Ladder, access deck and Deck UDG
- Steel Scaffold Tubes \varnothing 48.3 x 3.2 and Standard Couplers NK 48/48 (Fig. B4.04a)
- Ledger Braces UBL and Toeboards
- Ledger UH 75 and Ledger UH
- Ladder, access deck and Deck UDG (Fig. B4.04b)
- Ledger UH 75 and Ledger UH
- Locking Pins \varnothing 48/57
- Standards UVR
- Ledger-to-Ledger Coupler UHA Half with Spigot
- Ledger UHV 250 Plus
- Spindle Locking UJS
- Base Standard UVB (Fig. A4.04c)

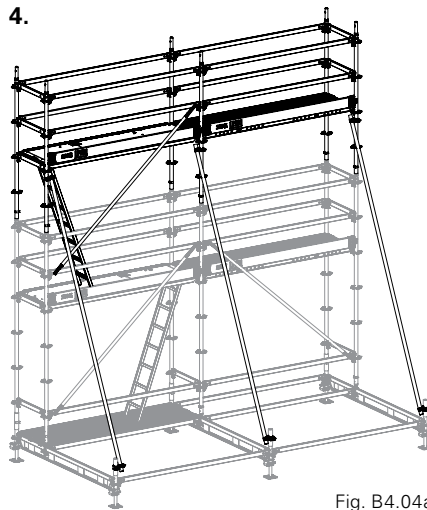

Fig. B4.04a

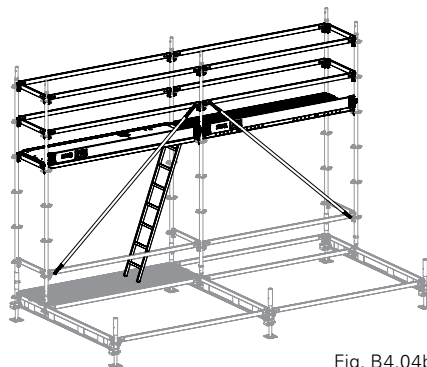

Fig. B4.04b

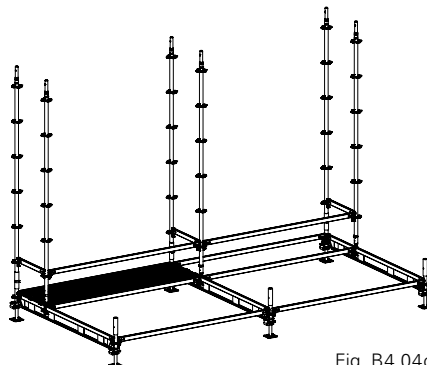
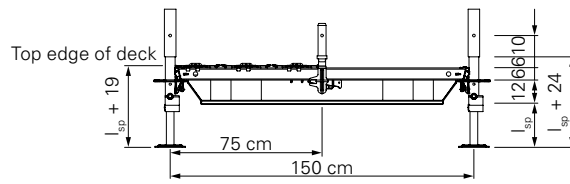

Fig. B4.04c

C1 Overview

Base width 150 cm

for bay lengths L (cm): 150, 200, 250, 300



Adjustable Base Plate UJB 38-50/30: $4 \leq l_{sp} \leq 26$ cm; move with crane $l_{sp} \geq 17$ cm

Standing height 224 - 260 cm

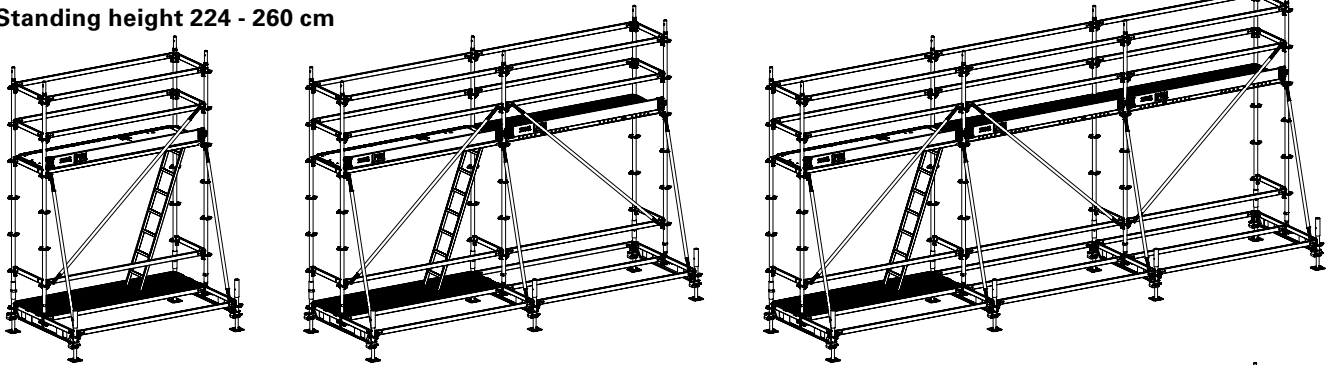

Standing height 424 - 460 cm

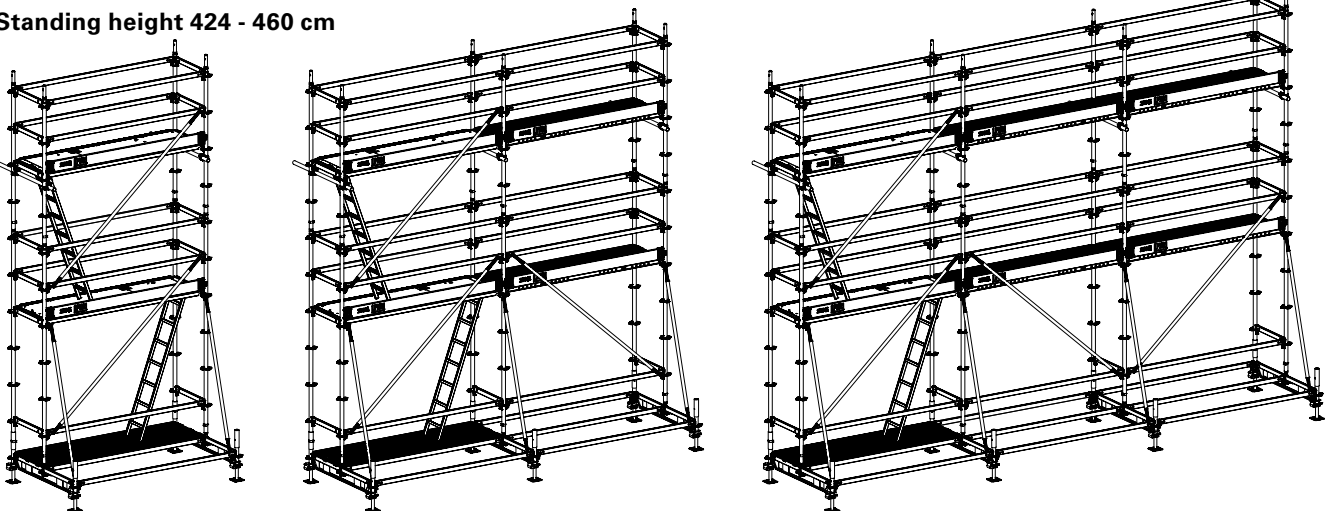

Standing height 624 - 660 cm

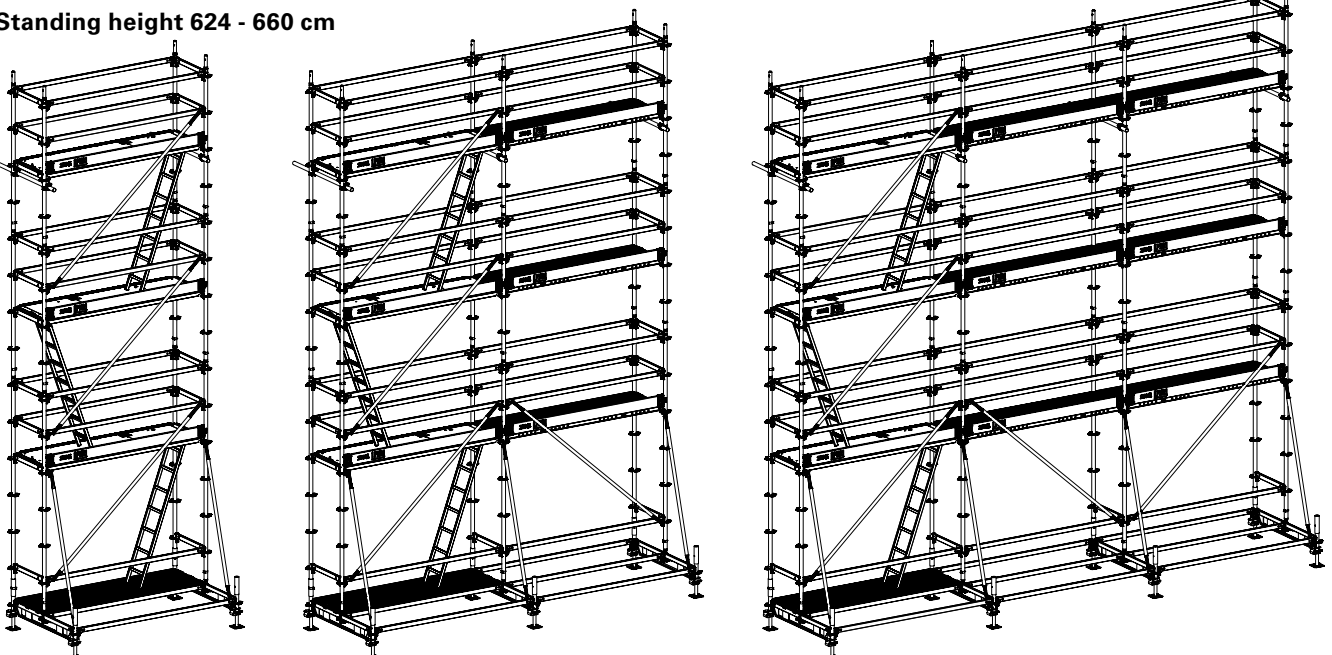

C1 Overview

Base width 250 cm

for bay lengths L (cm):
150, 200, 250, 300

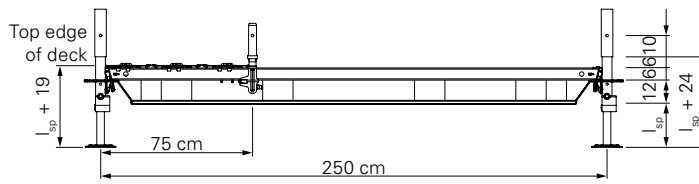

Adjustable Base Plate UJB
38-50/30: $4 \leq l_{sp} \leq 26$ cm;
move with crane $l_{sp} \geq 17$ cm

Standing height 824 - 880 cm

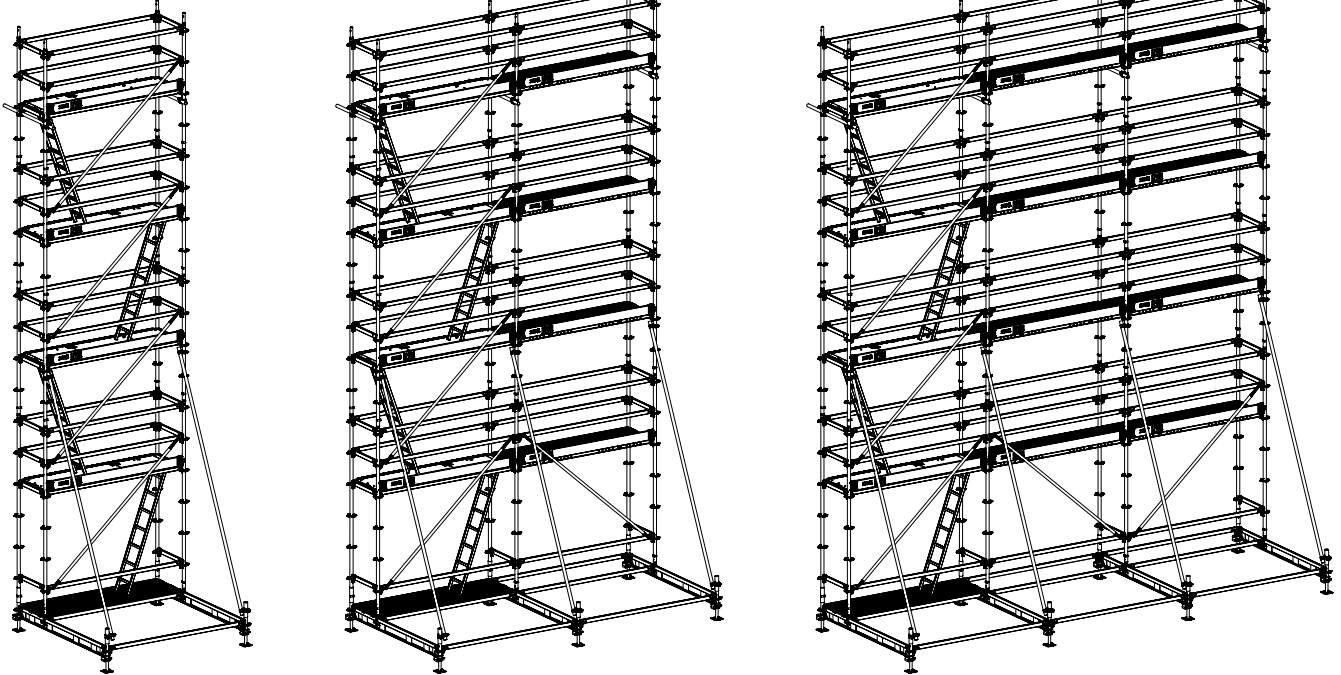

Standing height 1024 - 1080 cm

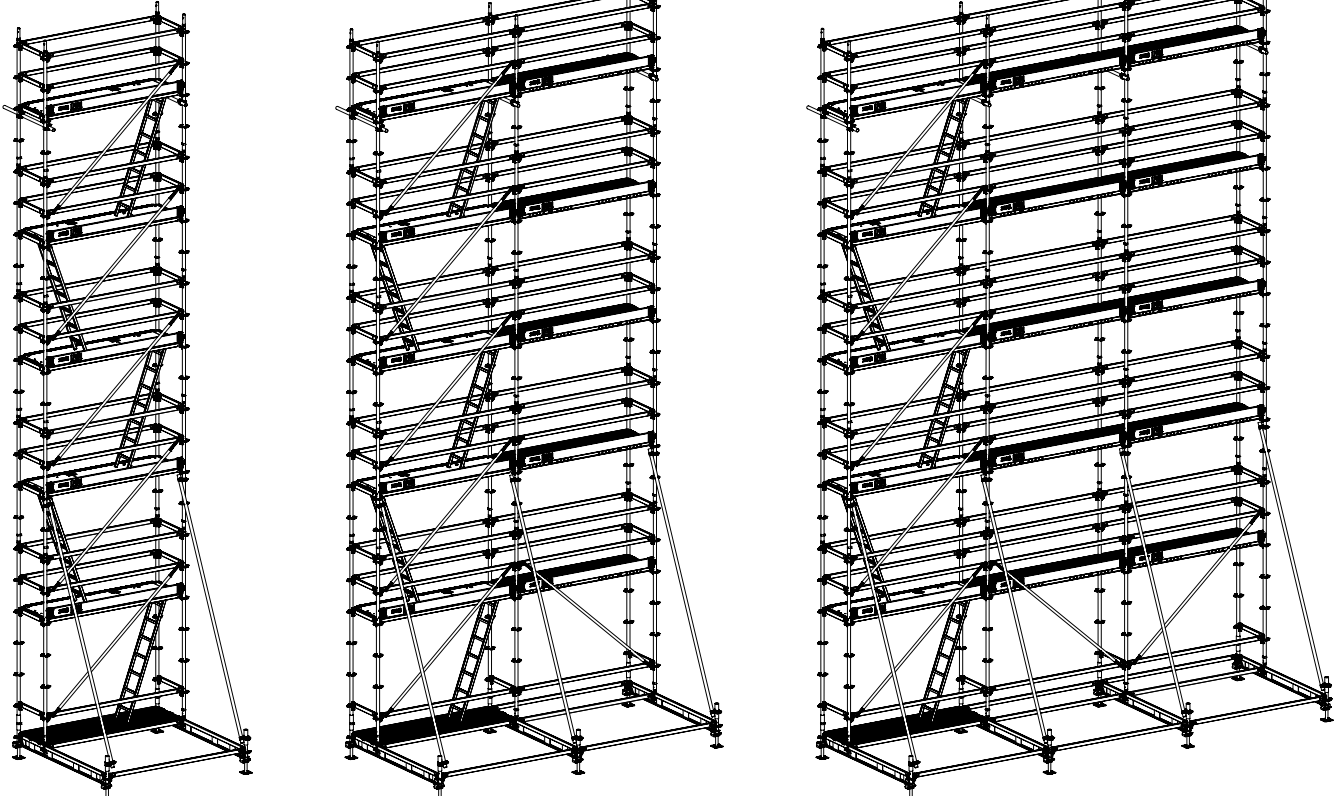

Live loads

The permissible live load for the reinforcement scaffold is 2.0 kN/m² as uniformly distributed load over one scaffolding level (corresponds to Load Class 3 according to DIN EN 12811).

If work is carried out on several scaffolding levels at the same time, then the total load must not exceed the permissible load of 3.0 kN/m² (2.0 kN/m² on one level + 1.0 kN/m² on an adjacent level).

Wind loads

Reaction forces and anchor forces for unclad reinforcement scaffold erected in front of a closed facade are determined under the following assumptions:

For free-standing reinforcement scaffold:
(pressure support)

$q = 0.1 \text{ kN/m}^2$ wind according to DIN EN 1004.

For reinforcement scaffold anchored at the top: (anchor positioned directly under the highest deck level)

Ledger UHV 150

$q = 0.2 \text{ kN/m}^2$ working wind load according to DIN EN 12811-1.

Ledger UHV 250

$q = 0.2 \text{ kN/m}^2$ working wind load according to DIN EN 12811-1.

Base Beam UVA 250

$q = 0.2 \text{ kN/m}^2$ working wind load according to DIN EN 12811-1.

C3 Reaction forces

Scaffold width 75 cm (100 cm)					
Standing height [cm]	Base width 150 cm Assembly on UHV 150		Base width 250 cm Assembly on UHV 250 / UVA 250		Standing height [cm]
	F_i [kN]	F_a [kN]	F_i [kN]	F_a [kN]	
224 – 260	5.1 (5.7)	2.2 (2.8)	5.1 (6.0)	1.9 (2.7)	224 – 260 / 248 – 280
424 – 460	7.3 (8.0)	3.7 (5.5)	8.0 (9.4)	3.0 (4.3)	424 – 460 / 448 – 480
624 – 660	8.6 (9.3)	4.9 (7.1)	9.3 (10.7)	3.6 (5.0)	624 – 660 / 648 – 680
			10.6 (12.2)	4.4 (5.9)	824 – 860 / 848 – 880
			12.1 (13.7)	5.2 (6.9)	1024 – 1060 / 1048 – 1080

Table C3.01

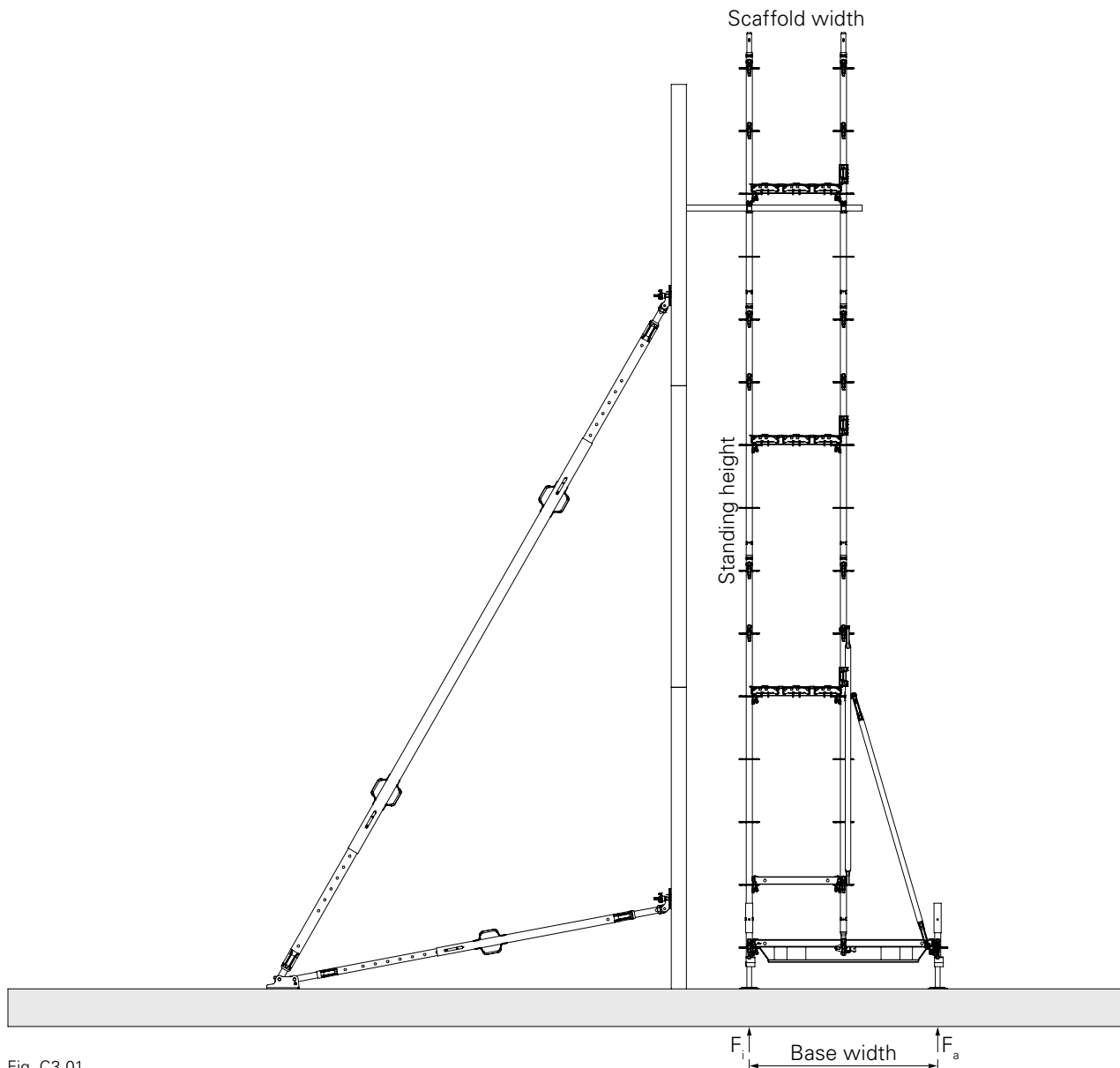
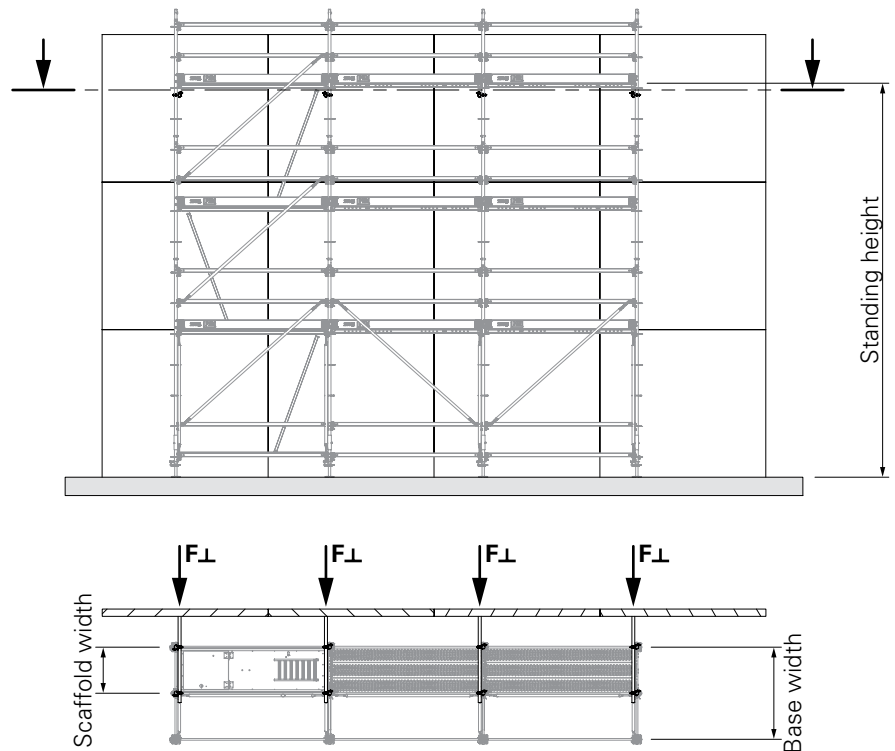

Fig. C3.01

Pressure-resistant ties are used for anchoring so that moving the reinforcement scaffold by crane is possible. Pressure-resistant ties are installed directly under the highest deck level on each Standard and are supported by being positioned against secure formwork units or solid wall.



For wind speeds $v > 17.9$ m/s (wind force 6), the reinforcement scaffolds are to be prevented from tipping over by means of tension and compression-proof anchorage.



Compression forces F_{\perp} [kN]

Scaffold width 75 cm (100 cm)			
Standing height [cm]	Base width 150 cm	Base width 250 cm	Standing height [cm]
	Assembly on UHV 150	Assembly on UHV 250 / UVA 250	
	Up to 17.9 m/s (wind force 6) only pressure-resistant ties required		
224 – 260	no ties required	no ties required	224 – 260 / 248 – 280
424 – 460	0.5 (0.5)	no ties required	424 – 460 / 448 – 480
624 – 660	0.5 (0.5)	1.1 (1.1)	624 – 660 / 648 – 680
		1.1 (1.1)	824 – 860 / 848 – 880
		1.1 (1.1)	1024 – 1060 / 1048 – 1080

Table C4.01

C5 Ballast

Required ballast for the PERI UP Flex Reinforcement Scaffold 75 and 100 with working wind speed according to DIN EN 12811.

Scaffold width 75 cm				Scaffold width 100 cm				
Bays	1 bay			1 bay				Bays
Height / bay length [cm]	150	200	250	150	200	250	300	Height / bay length [cm]
224 – 260	-	-	-	40 kg	40 kg	40 kg	40 kg	224 – 260
424 – 460	160 kg	-	-	160 kg	-	-	-	424 – 460
624 – 660	400 kg	120 kg	-	400 kg	80 kg	-	-	624 – 660
824 – 880	760 kg	320 kg	-	840 kg	320 kg	-	-	824 – 880
1024 – 1080	1160 kg	560 kg	160 kg	1280 kg	640 kg	200 kg	-	1024 – 1080

Table C5.01

For smaller scaffolding dimensions, no additional ballast is required.

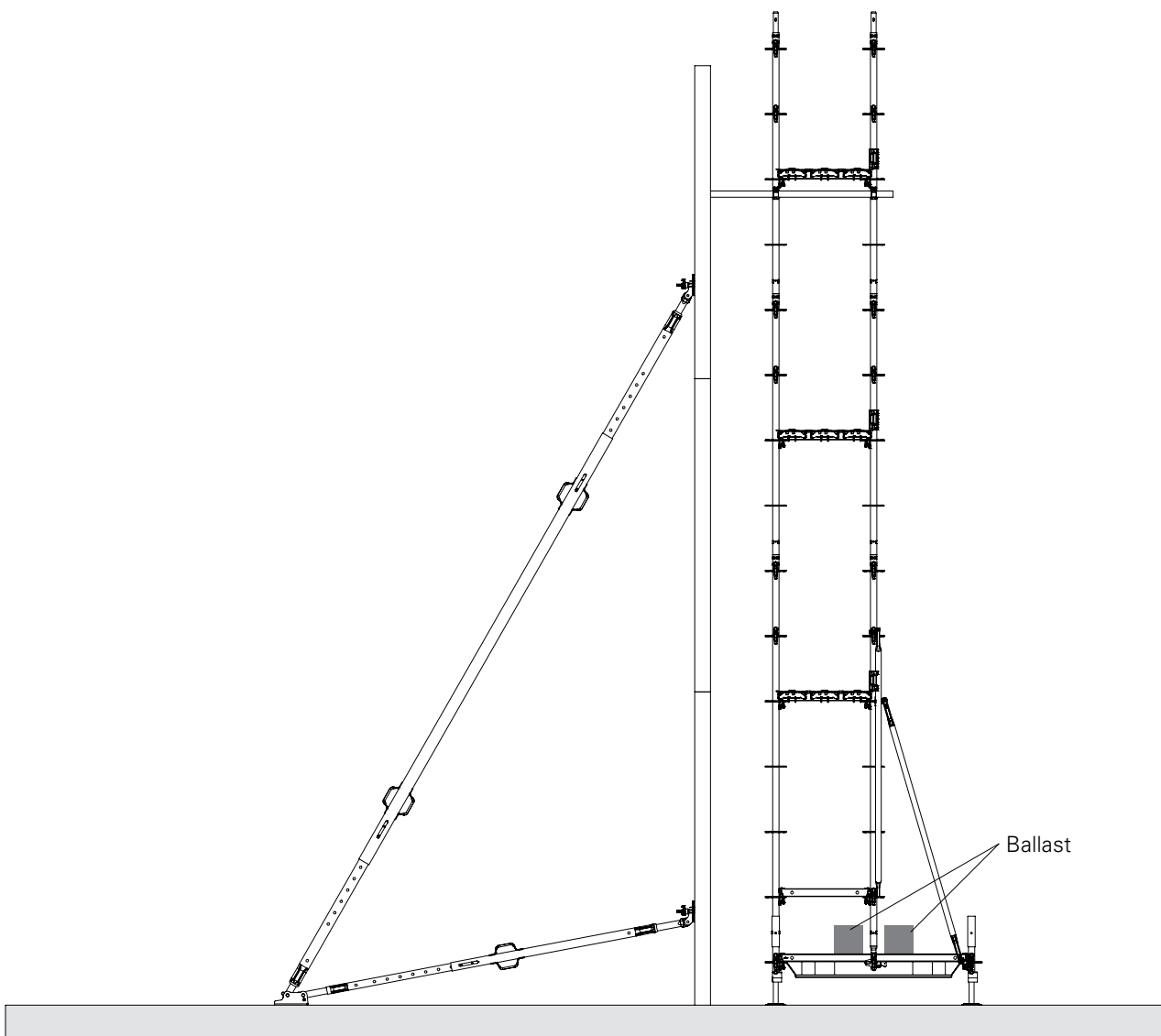

Fig. C5.01

D1 Moving by crane



Danger

Risk of injury!

⇒ Do not stand under the suspended load.



Requirements:

- Ensure that all Standards are tightly connected!
- Remove loose parts!

Load-bearing points

For moving by crane, webbing belts for example can directly be wrapped around the Standards under the rosettes (Fig. D1.01). The complete reinforcement scaffold unit is moved using four-sling lifting gear (Fig. D1.01a + D1.01b + D1.01c).

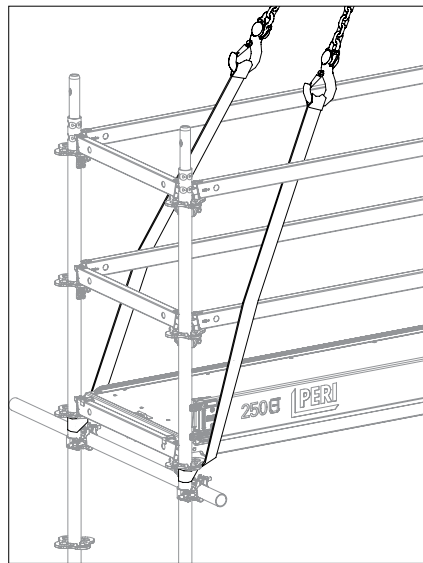

Fig. D1.01

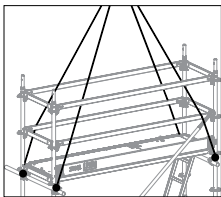

Fig. D1.01a

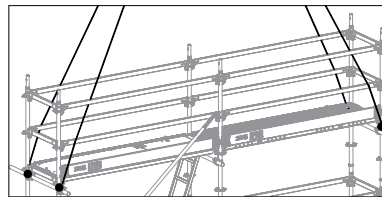

Fig. D1.01b

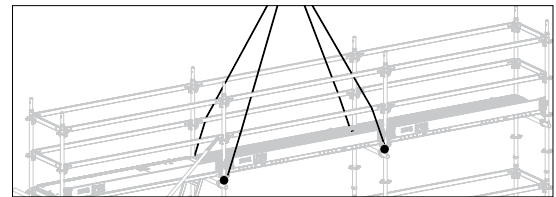

Fig. D1.01c

Dead loads

Scaffold width 75 cm (100 cm)							
Standing height [cm]	Base width 150 cm Assembly on UHV 150			Base width 250 cm Assembly on UHV 250 / UVA 250			Standing height [cm]
	1 bay 300 cm	2 bays 600 cm	3 bays 900 cm	1 bay 300 cm	2 bays 600 cm	3 bays 900 cm	
	max. dead load [kg]			max. dead load [kg]			
224 – 260	310 (340)	500 (550)	680 (760)	400 (430)	640 (700)	880 (960)	224 – 260 / 248 – 280
424 – 460	450 (510)	750 (850)	1040 (1180)	540 (600)	890 (990)	1230 (1380)	424 – 460 / 448 – 480
624 – 660	590 (680)	990 (1140)	1390 (1600)	680 (770)	1130 (1290)	1580 (1800)	624 – 660 / 648 – 680
				820 (930)	1380 (1580)	1940 (2230)	824 – 860 / 848 – 880
				960 (1100)	1630 (1880)	2290 (2650)	1024 – 1060 / 1048 – 1080

Table D1.01

Assembly tips



Warning

Risk of falling!

- ⇒ During work operations, keep the hatch closed.
- ⇒ Use PPE to prevent falling.

First scaffold bay

- In order to be able to immediately install the Ledgers UH (guardrails), Standards UVR are always slotted in 1 m above the decking level.
- From a safe working position, the front side and outer Ledgers UH are installed.

Additional scaffold bays

For any additional scaffold bays, the outer Ledgers UH are mounted from a safe position (previous scaffold bay) (e.g. PPE).

End guardrail

Mount Ledger UH 75 from a safe position (previous scaffold bay) (e.g. PPE).

Reinforcement work tips

The reinforcement scaffold is positioned 30 – 80 cm in front of the primary formwork. Guardrails are therefore required on the inner side of the reinforcement scaffold. They provide a safe working position:

1. One leg is wrapped around the bottom Ledger UH.
2. Lean against the top Ledger UH and lean forward.

(Fig. D2.03)

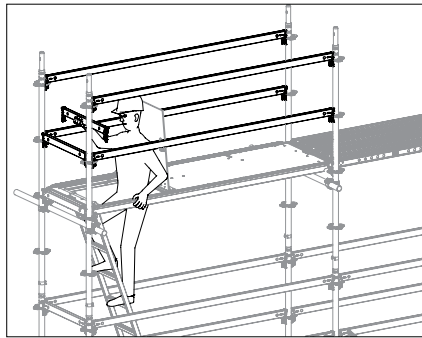

Fig. D2.01

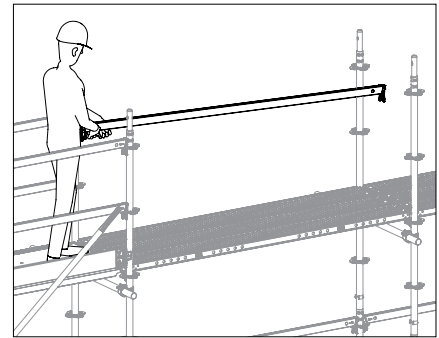

Fig. D2.02

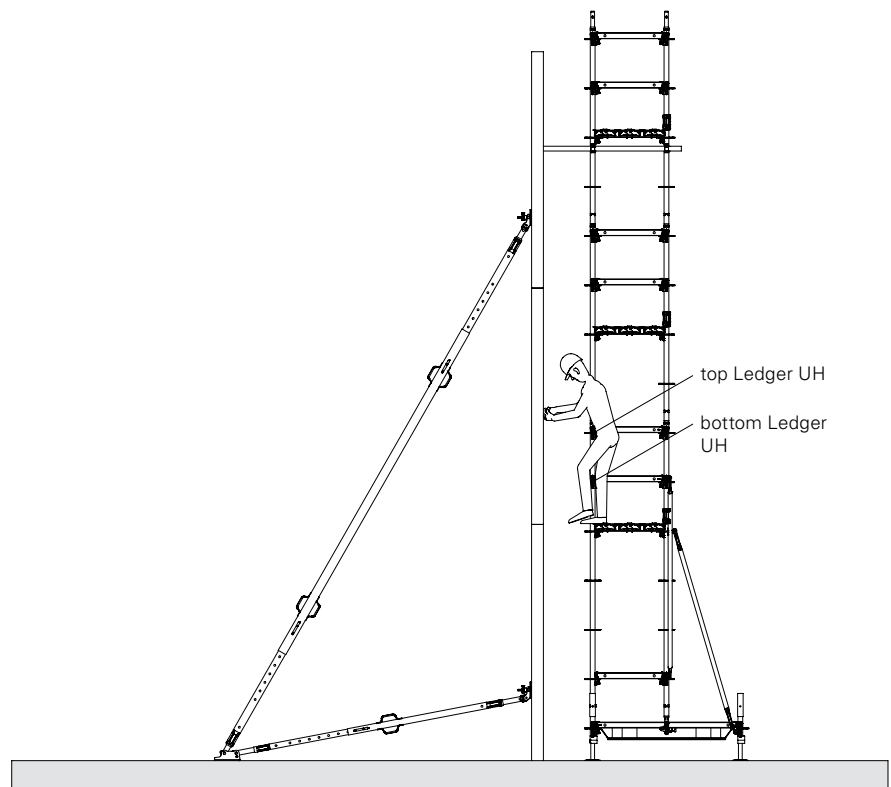

Fig. D2.03

D3 Assembly with guardrail in advance

Assembly of the reinforcement scaffold with Ledger UH as guardrail is shown in Sections A and B.

If the top Ledger is replaced by a guardrail, assembly with the guardrail in advance can then take place.

The following components are required:

- 20** Guardrail Holder EPW
- 21** Guardrail EPG
- 22** End Guardrail UPA in advance

Assembly

1. Insert Guardrail Holder EPW (20) into the top rosette of the Standard UVR and wedge securely.
2. Insert the first two Standards UVR. (Fig. D3.01)
3. Mount Guardrail EPG (21) on the Guardrail Holder EPW of the outer Standard. (Fig. D3.02)
4. Connect the next Standard UVR with the Guardrail UPG.
5. Insert Standard UVR complete with Guardrail EPG. (Fig. D3.03)
6. On the inner side of the next guardrail, mount Standards in advance.
7. Install Ledger UH.
8. Install End Guardrail in advance UPA (22). (Fig. D3.04)
9. Install decking or decking with ladder. (Fig. D3.05)
10. Repeat steps 3 to 8 for the next bays and mount components to ensure stability. (Fig. D3.06)

Ensure that the side protection is complete with Ledgers and Toeboards when accessing the top level.

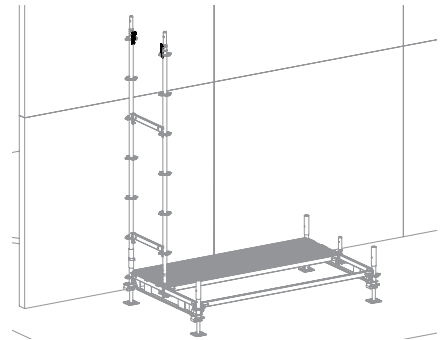
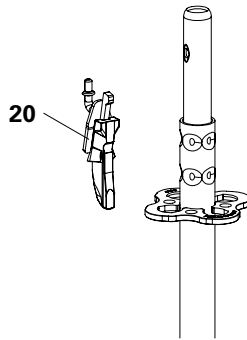

Fig. D3.01

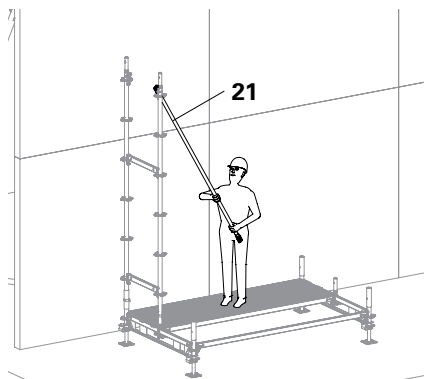

Fig. D3.02

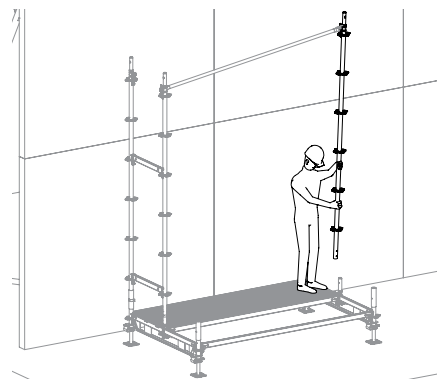

Fig. D3.03

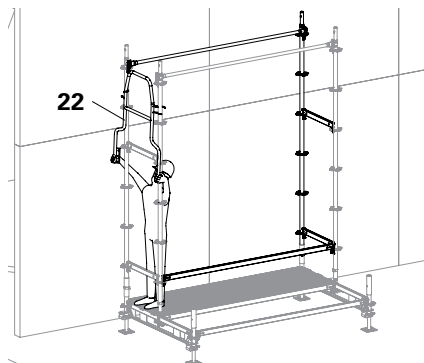

Fig. D3.04

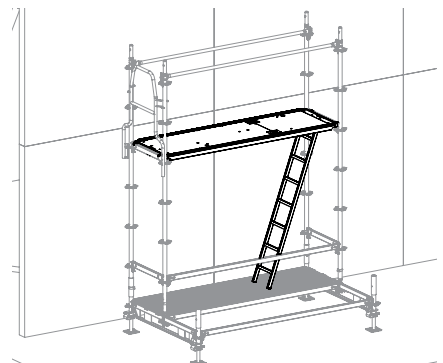

Fig. D3.05

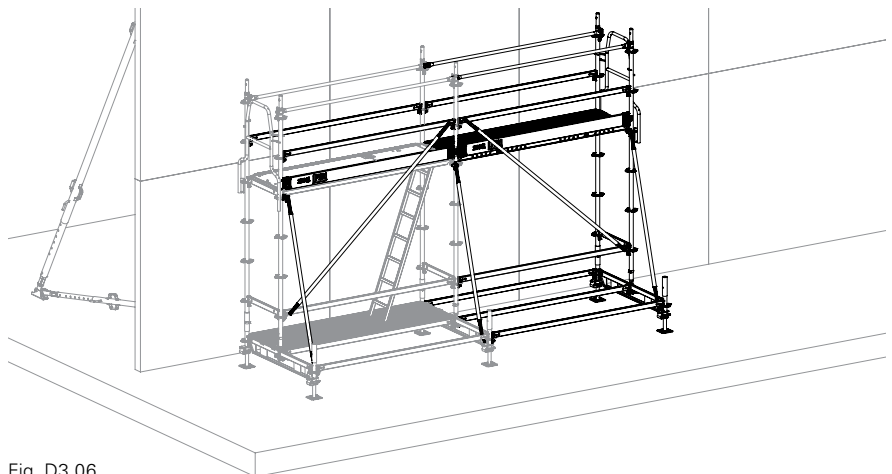

Fig. D3.06

E1 Optional/alternative components

Components are to be installed as an option or as an alternative if required by local standards and regulations.

In this example, the Locking Pins \varnothing 48/57 (17) have been replaced by bolts (Bolt ISO 4014 M10 x 70-8.8) and continuous side protection consisting of Ledgers UH in the bay of ascent is mounted on the ladder.

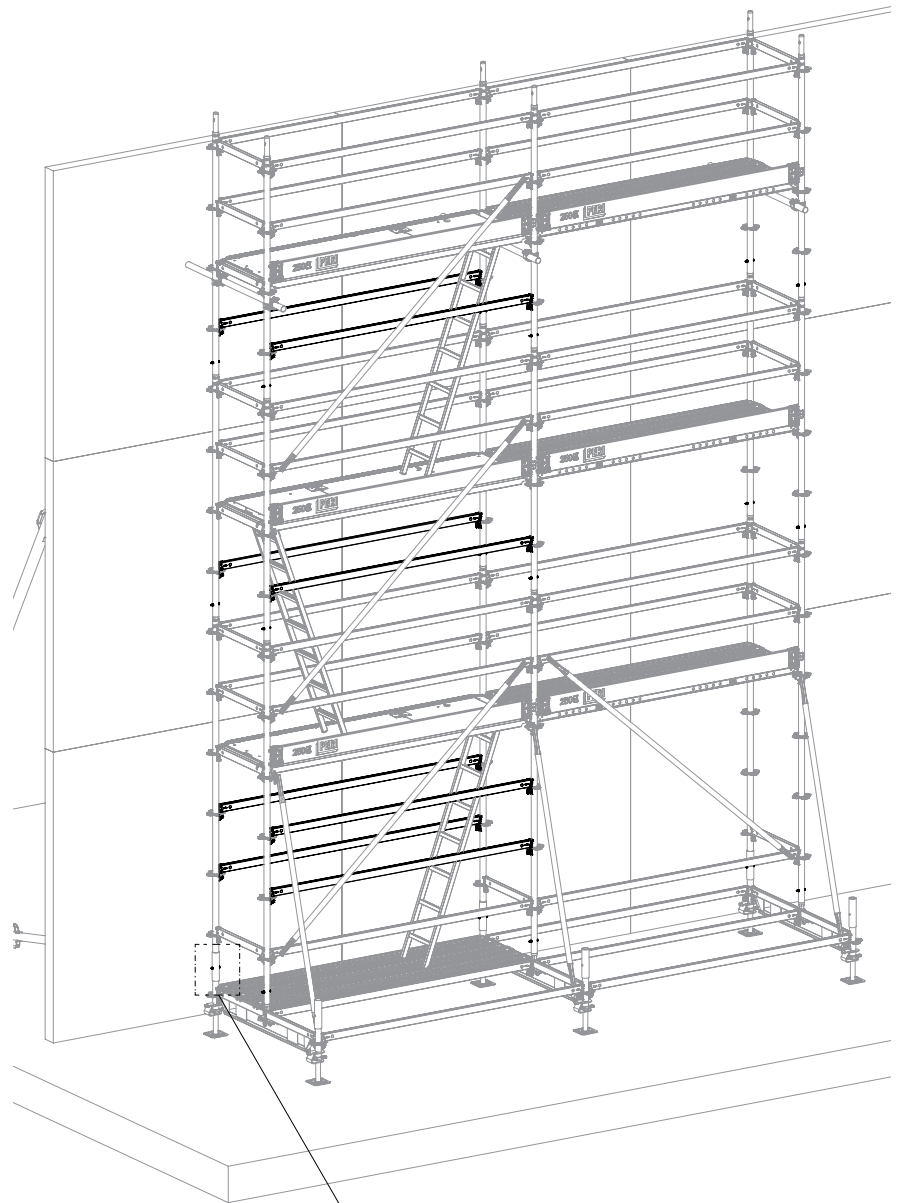
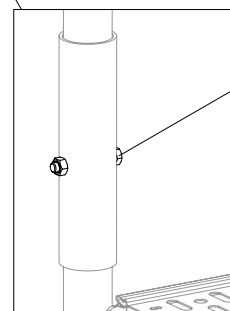

Fig. E1.01



Bolt ISO 4014 M10 x 70-8.8

Fig. E1.01a

E2 Scaffold width 100 cm

Base width 150 cm / bay length 250

All scaffold versions can also be assembled using a width of 100 cm.

The following changes are to be made:

- Ledger UH 100 Plus (3a) instead of Ledger UH 75 Plus
- 4x Steel Deck UDG (10) instead of 3x Steel Deck UDG
- Access Deck UAL-3 + 1x Steel Deck UDG (10) instead of Access Deck UAL-3

Standing height 224 - 660 cm

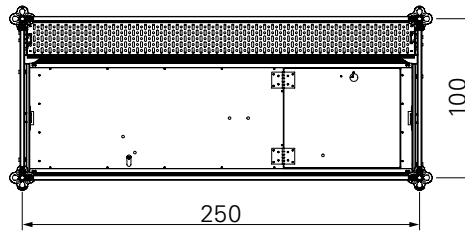

Fig. E2.01a

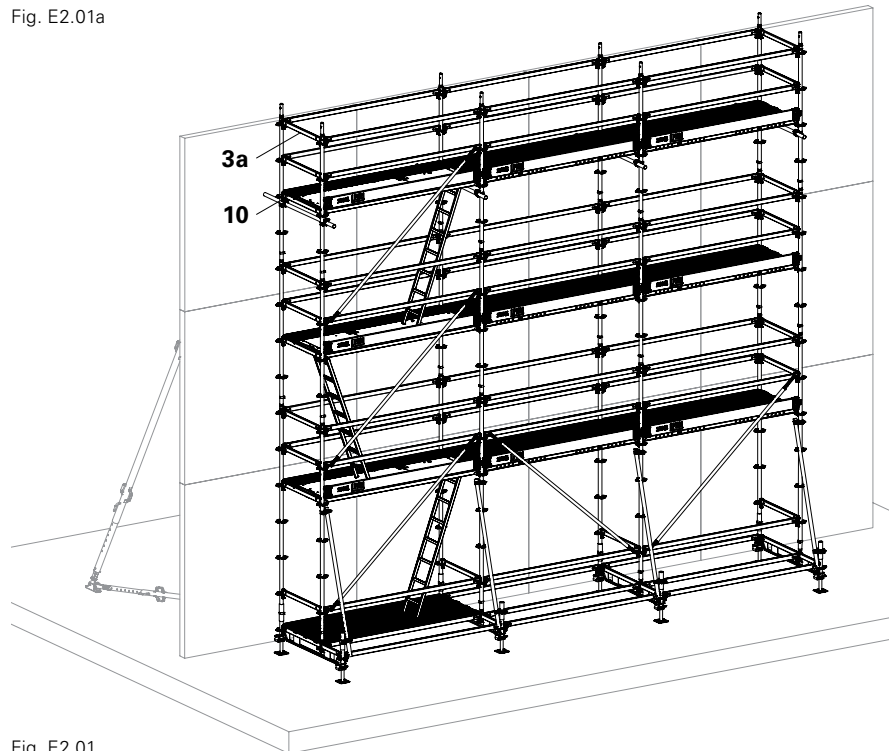

Fig. E2.01

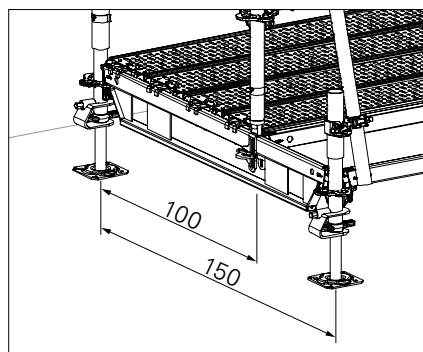

Fig. E2.01b

E2 Scaffold width 100 cm

Base width 250 cm / bay length 250

All scaffold versions can also be assembled using a width of 100 cm.

The following changes are to be made:

- Ledger UH 100 Plus (3a) instead of Ledger UH 75 Plus
- 4x Steel Deck UDG (10) instead of 3x Steel Deck UDG
- Access Deck UAL-3 + 1x Steel Deck UDG (10) instead of Access Deck UAL-3

Standing height 224 - 1060 cm

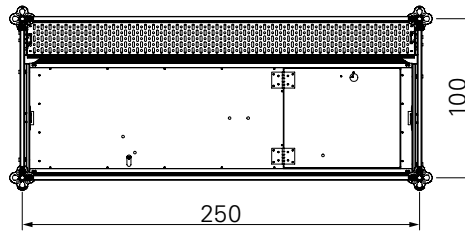

Fig. E2.02a

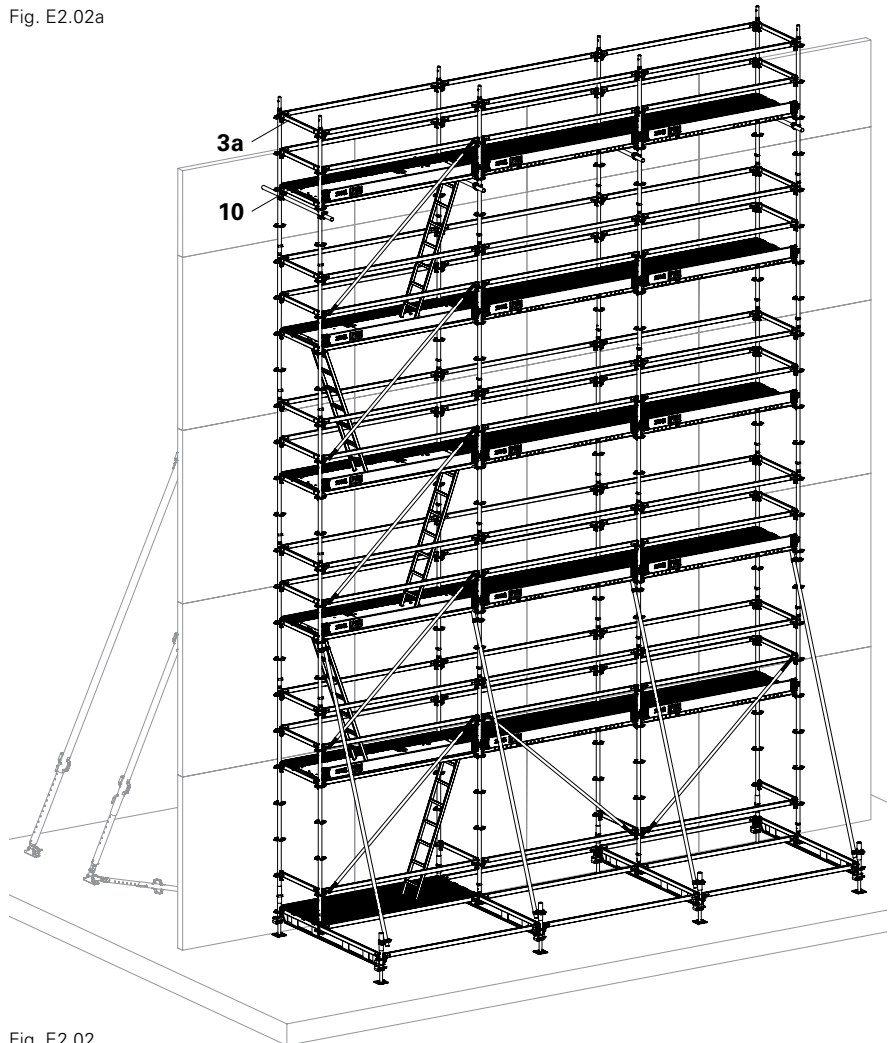

Fig. E2.02

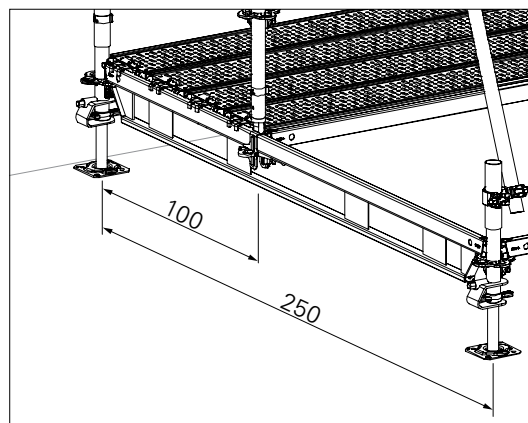

Fig. E2.02b

E3 Bay length 300 cm

Scaffold width 75 cm

For bay lengths of 300 cm and scaffold widths of 75 cm, components must be installed in addition to the Access Deck (7) in the bay of ascent.

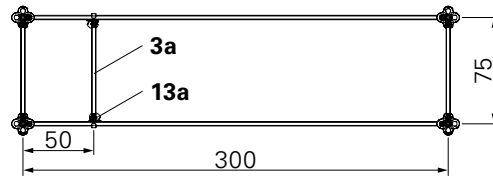

Fig. E3.01a

Additional components:

- UH 75 Plus (3a)
- Ledger-to-Ledger Coupler UHA (13a)
- 2x Steel Deck UDG 25 x 75 (10)

The following changes are to be made:

- UH 300 Plus instead of Ledger UH 250 Plus

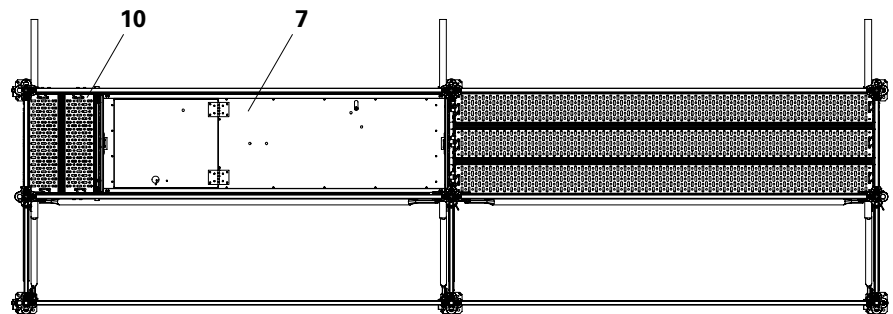

Fig. E3.01

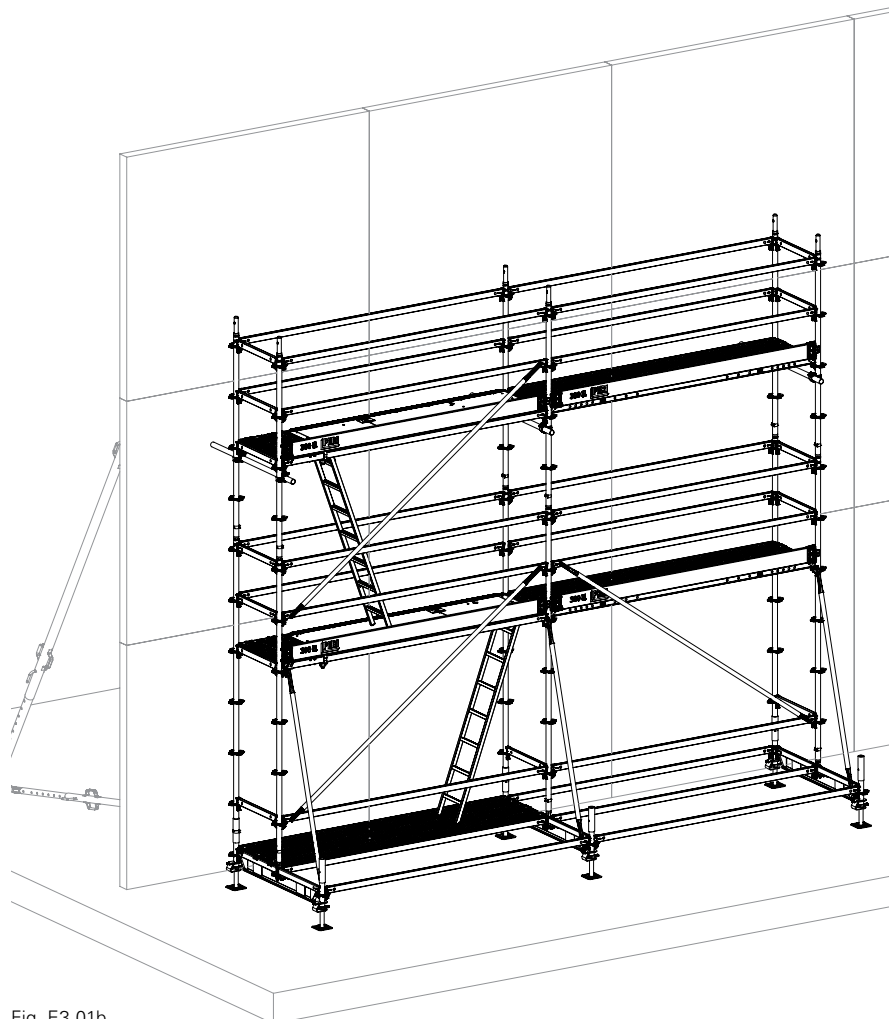

Fig. E3.01b

E3 Bay length 300 cm

Scaffold width 100 cm

For bay lengths of 300 cm and scaffold widths of 100 cm, components must be installed in addition to the Access Deck (7) in the bay of ascent.

Additional components:

- Ledger UH 100 Plus (3)
- Ledger-to-Ledger Coupler UHA (13a)
- 2x Steel Deck UDG 25 x 100 (10a)
- 1x Steel Deck UDG 25 x 250 (10)

The following changes are to be made:

- UH 300 Plus instead of Ledger UH 250 Plus

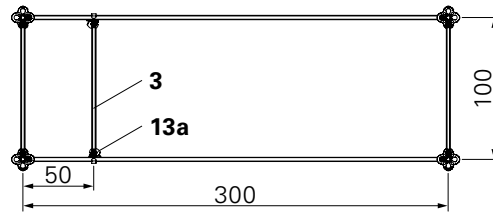

Fig. E3.02a

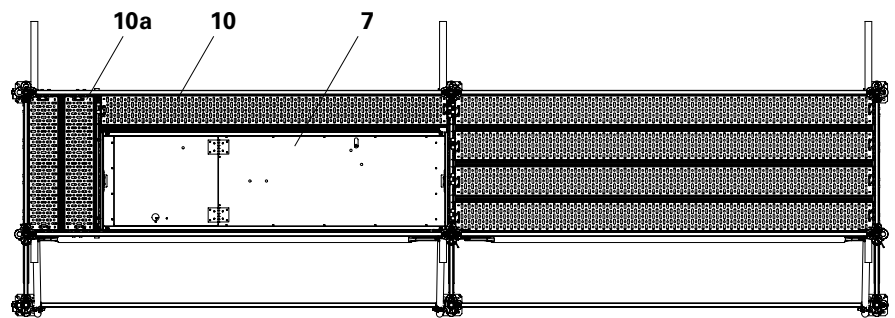

Fig. E3.02

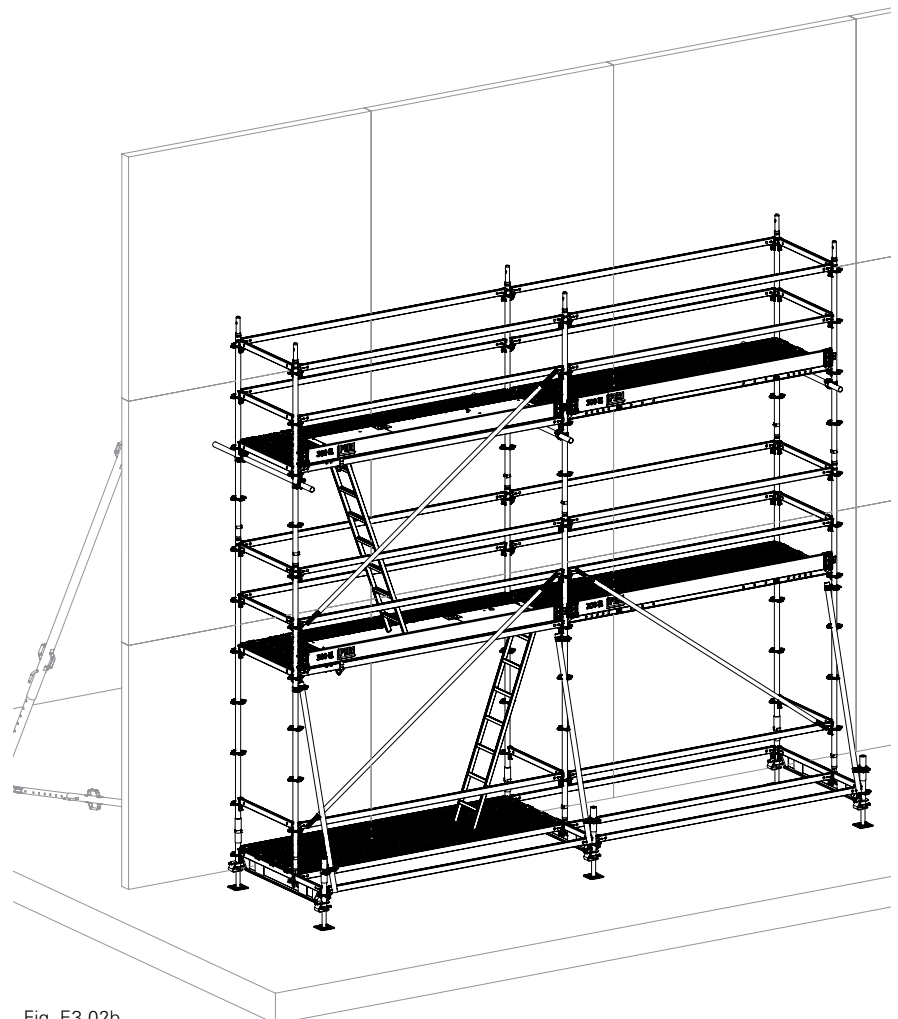

Fig. E3.02b

As an alternative to the Ledger UHV 250, the Base Beam UVA 250 can be used.

Assembly

1. Prepare Base Beam UVA (20) for the one-sided assembly with a 75 cm (or 100 cm) width.
2. Position Adjustable Base Plates UJB (1) with Base Beam UVA (20) (wedges are inside). Assemble frame using Ledger UH (3).
3. Horizontally align frame by adjusting the Adjustable Base Plates.
Max. spindle adjustment range for
 - Base Plate UJB 38-50/30: ≤ 35 cm
 - Base Plate UJB 38-80/55: ≤ 35 cm
4. Establish perpendicularity of the base.
5. Insert Base Standard UVB (2) and mount Ledger UH 75 (3a).
6. Secure wedges on all Ledgers using a 500 g hammer.
7. Insert Steel Decks UDG (10). Standing position: below.
8. Secure Adjustable Base Plate UJB with Spindle Locking UJS (16). (Fig. E4.01)
9. Additional assembly as described in Sections B1 - B3. (Fig. E4.02)

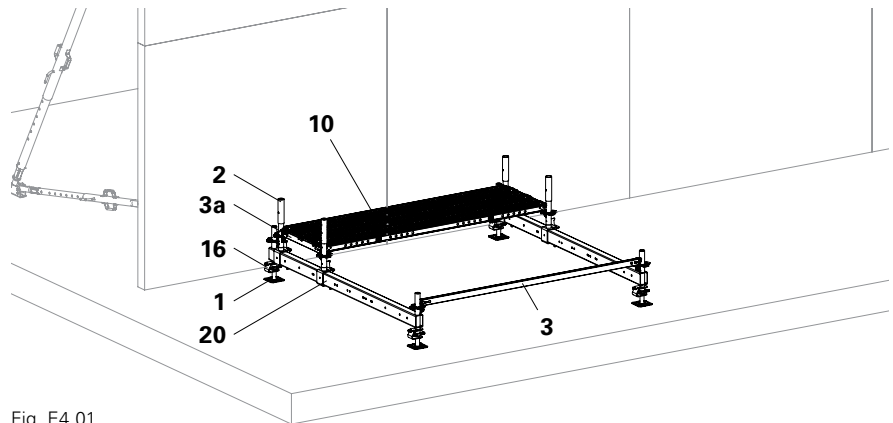

Fig. E4.01

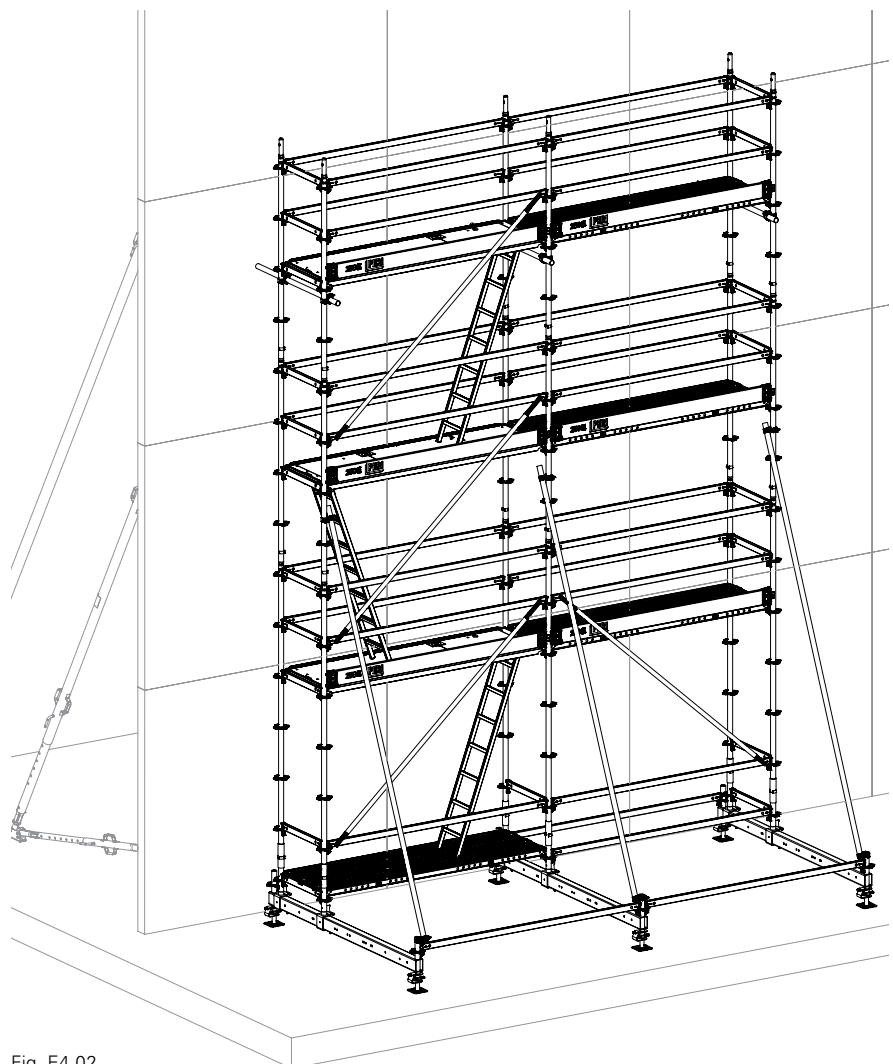

Fig. E4.02

E5 Hatch UAF

As an alternative to the Access Deck UAL-3, the Hatch UAF can be mounted.

Assembly

1. Attach Ledgers UH (3) and securely fix with wedges.
2. Securely fix wedges for Ledger-to-Ledger Coupler UHA (13a).
3. Install Ledger UH 75 (3a) on Ledger-to-Ledger Couplers UHA (13a) at spacings of 100 cm as support for Hatch UAF. (Fig. E5.01)
4. Mount Hatch UAF (21) and Steel Deck UDG (10). Standing position: below.
→ Lift-off prevention devices drop under the UH Ledger (3a) and secure the decking.
5. Attach Ladder UAF (22). (Fig. E5.02)
6. Additional assembly as described in Sections A1 - A3 or B1 - B3.

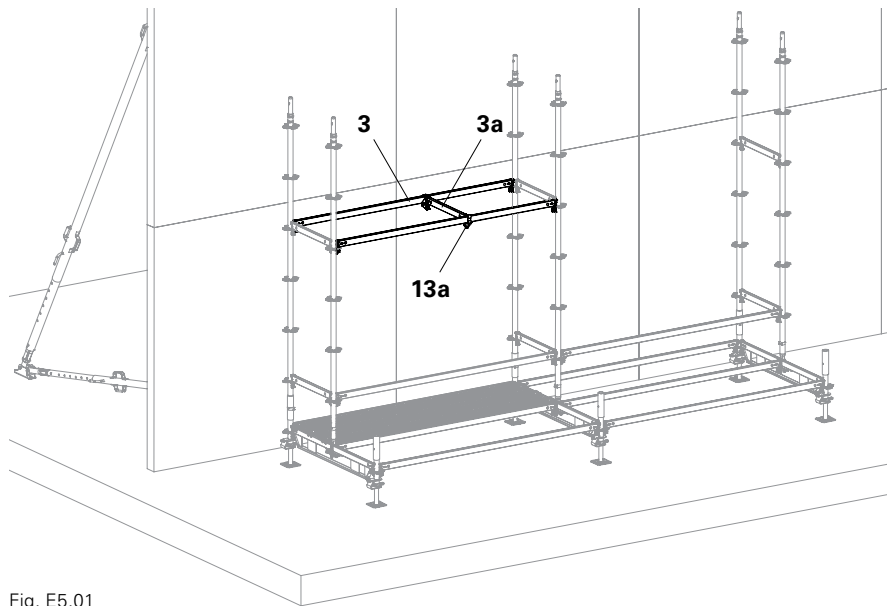

Fig. E5.01

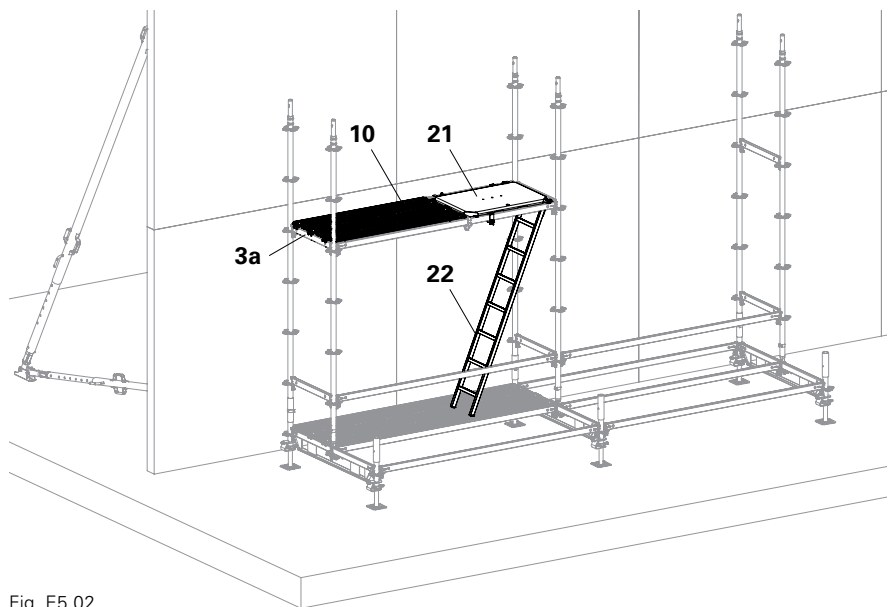

Fig. E5.02

E6 Coupler Braces UBC

Alternatively, instead of the Node Brace UBK, the Coupler Brace UBC can be mounted for stability.

Assembly

Mount Coupler Brace UBC (23) at the top to the outside Standard. Mount at bottom with Swivel Coupling 48/60 (14b) to the Base Standard UVB 24. (Fig. E6.01)

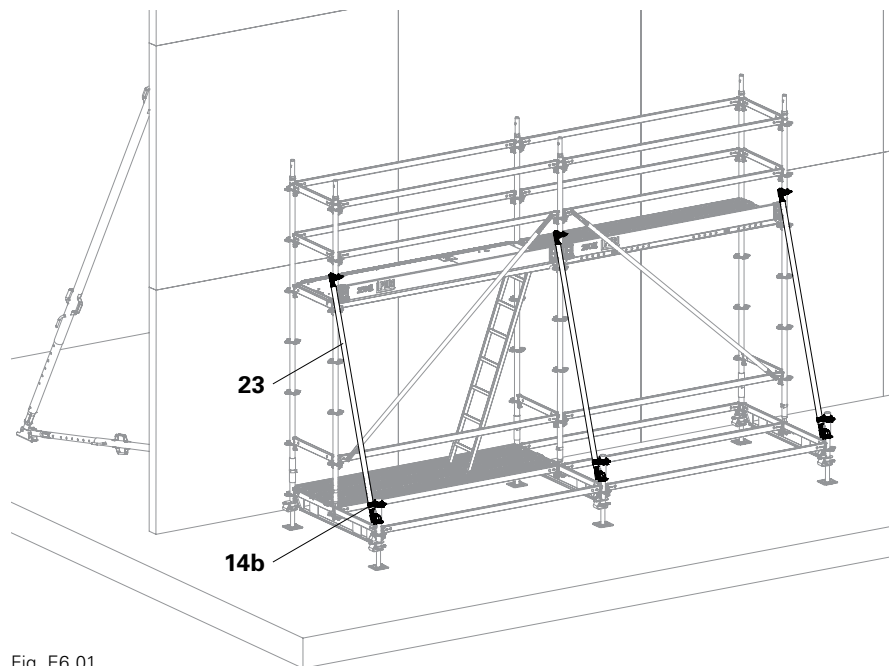

Fig. E6.01

E7 External stairs



Follow Instructions for Assembly and Use for PERI UP Flex Stairs 75.

As an alternative to the Access Deck UAL-3 and UAF-3, stairs can be mounted to the outside of the reinforcement scaffold. (Fig. E7.01)

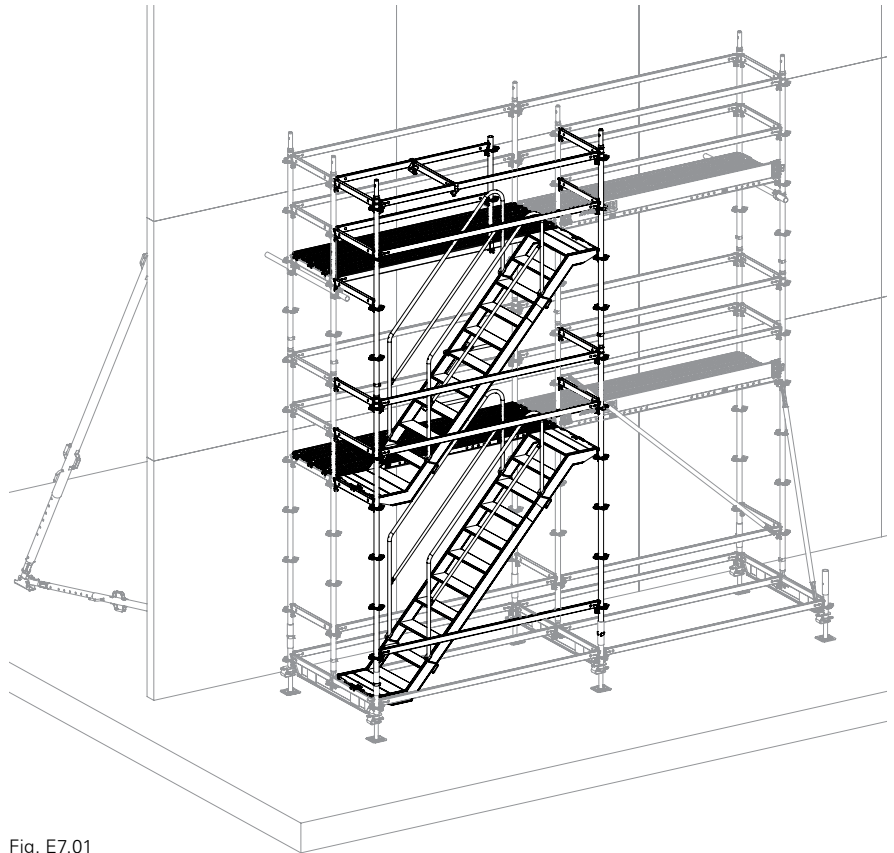
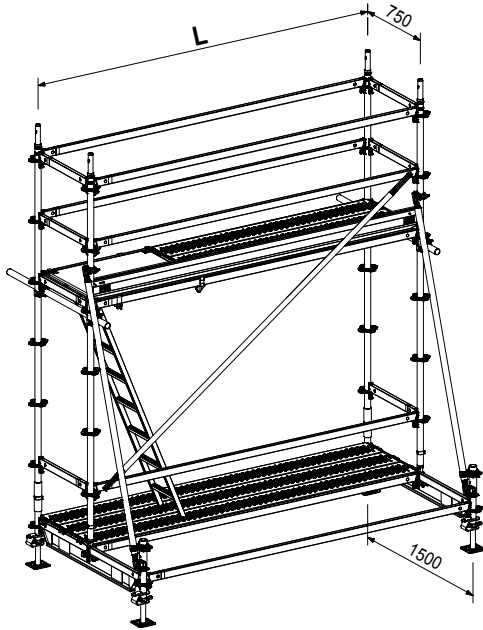

Fig. E7.01

PERI UP Flex Reinforcement Scaffold 75 and 100



Item no.	Weight kg		L
001090	326.698	Reinforcement Scaffold UDI/UDG Basic	
		Reinforce. Scaff. UDI/UDG Basic 200 x 150/75	2000
001094	358.268	Reinforce. Scaff. UDI/UDG Basic 250 x 150/75	2500
001098	390.268	Reinforce. Scaff. UDI/UDG Basic 300 x 150/75	3000



Item no.	Weight kg		L
001091	147.758	Reinforcement Scaffold UDI/UDG Basic Plus	
		Reinforce. Scaff. UDI/UDG Basic Plus 200/75	2000
001095	165.948	Reinforce. Scaff. UDI/UDG Basic Plus 250/75	2500
001099	184.268	Reinforce. Scaff. UDI/UDG Basic Plus 300/75	3000

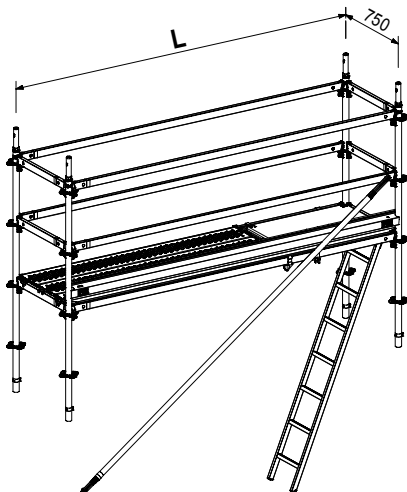

PERI UP Flex Reinforcement Scaffold 75 and 100



Item no.	Weight kg		L
001107	164.328	Reinforcement Scaffold UDI/UDG Add.	
		Reinforce. Scaff. UDI/UDG Add. 150 x 150/75	1500
001092	178.038	Reinforce. Scaff. UDI/UDG Add. 200 x 150/75	2000
001096	198.628	Reinforce. Scaff. UDI/UDG Add. 250 x 150/75	2500
001100	219.618	Reinforce. Scaff. UDI/UDG Add. 300 x 150/75	3000

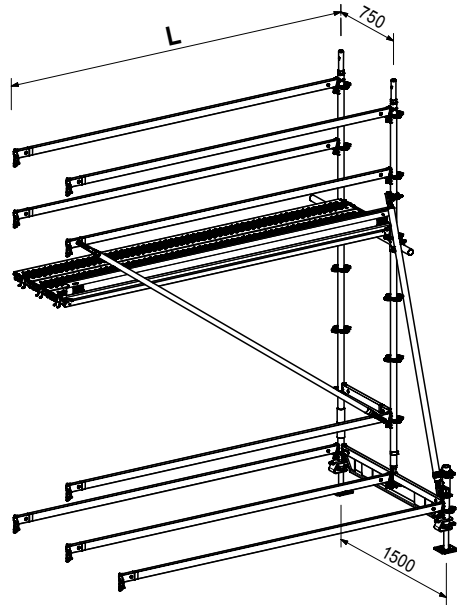

			L
		Reinforcement Scaffold UDI/UDG Add Plus	
001108	72.918	Reinforce. Scaff. UDI/UDG Add. Plus 150/75	1500
001093	87.638	Reinforce. Scaff. UDI/UDG Add. Plus 200/75	2000
001097	102.048	Reinforce. Scaff. UDI/UDG Add. Plus 250/75	2500
001101	116.768	Reinforce. Scaff. UDI/UDG Add. Plus 300/75	3000

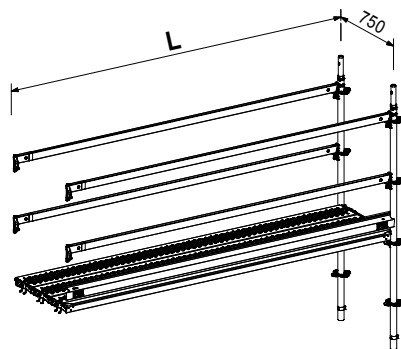

PERI UP Flex Reinforcement Scaffold 75 and 100



Item no.	Weight kg		L
001109	372.100	Reinforcement Scaffold UDI/UDG Basic	
		Reinforce. Scaff. UDI/UDG Basic 200 x 150/100	2000
001113	410.390	Reinforce. Scaff. UDI/UDG Basic 250 x 150/100	2500
001117	449.310	Reinforce. Scaff. UDI/UDG Basic 300 x 150/100	3000

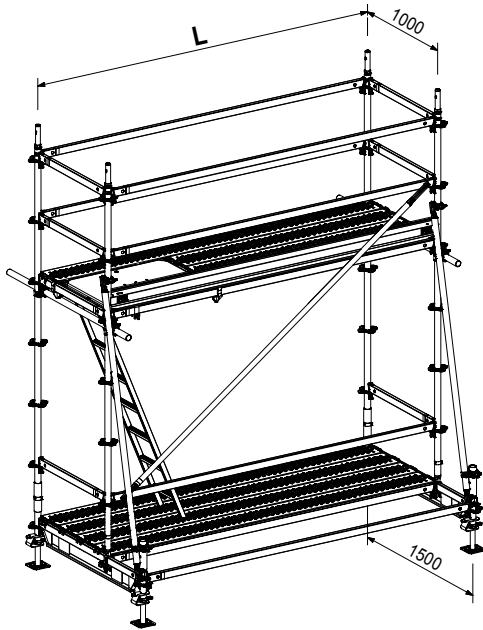

			L
001110	177.640	Reinforcement Scaffold UDI/UDG Basic Plus	
		Reinforce. Scaff. UDI/UDG Basic Plus 200/100	2000
001114	199.850	Reinforce. Scaff. UDI/UDG Basic Plus 250/100	2500
001118	222.290	Reinforce. Scaff. UDI/UDG Basic Plus 300/100	3000

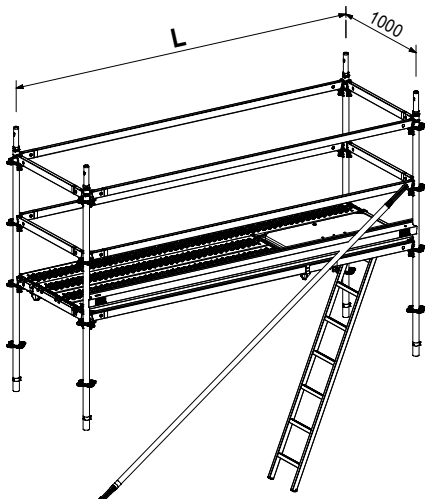

PERI UP Flex Reinforcement Scaffold 75 and 100



Item no.	Weight kg		L
001121	169.958	Reinforcement Scaffold UDI/UDG Add.	
001111	193.558	Reinforce. Scaff. UDI/UDG Add. 150 x 150/100	1500
001115	216.848	Reinforce. Scaff. UDI/UDG Add. 200 x 150/100	2000
001119	240.638	Reinforce. Scaff. UDI/UDG Add. 250 x 150/100	2500
		Reinforce. Scaff. UDI/UDG Add. 300 x 150/100	3000

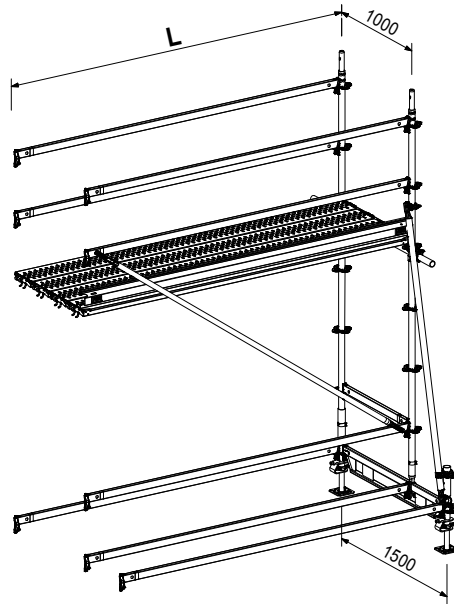

Item no.	Weight kg		L
001122	83.988	Reinforcement Scaffold UDI/UDG Add. Plus	
001112	101.498	Reinforce. Scaff. UDI/UDG Add. Plus 150/100	1500
001116	118.608	Reinforce. Scaff. UDI/UDG Add. Plus 200/100	2000
001120	136.128	Reinforce. Scaff. UDI/UDG Add. Plus 250/100	2500
		Reinforce. Scaff. UDI/UDG Add. Plus 300/100	3000

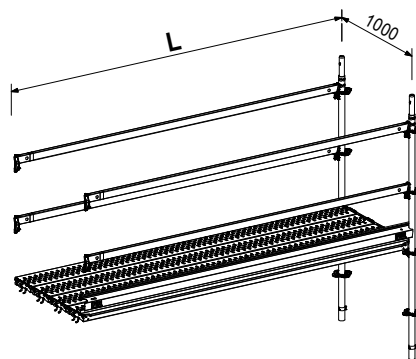

PERI UP Flex Reinforcement Scaffold 75 and 100



Item no.	Weight kg		L
001123	401.134	Reinforcement Scaffold UDI/UDG Basic UVA	
		Reinforce. Scaff. Basic UVA 200 x 250/75	2000
001125	431.384	Reinforce. Scaff. Basic UVA 250 x 250/75	2500
001127	462.064	Reinforce. Scaff. Basic UVA 300 x 250/75	3000

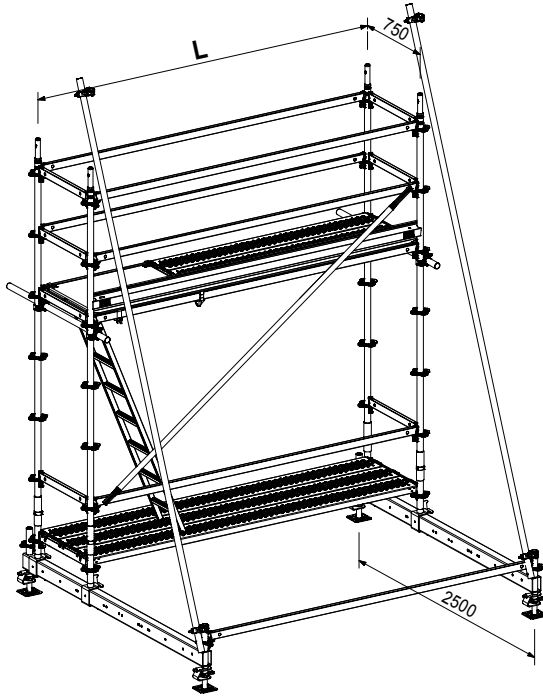

		Reinforcement Scaffold UDI/UDG Add. UVA	L
001129	192.756	Reinforce. Scaff. Add. UVA 150 x 250/75	1500
001124	212.236	Reinforce. Scaff. Add. UVA 200 x 250/75	2000
001126	231.506	Reinforce. Scaff. Add. UVA 250 x 250/75	2500
001128	251.176	Reinforce. Scaff. Add. UVA 300 x 250/75	3000

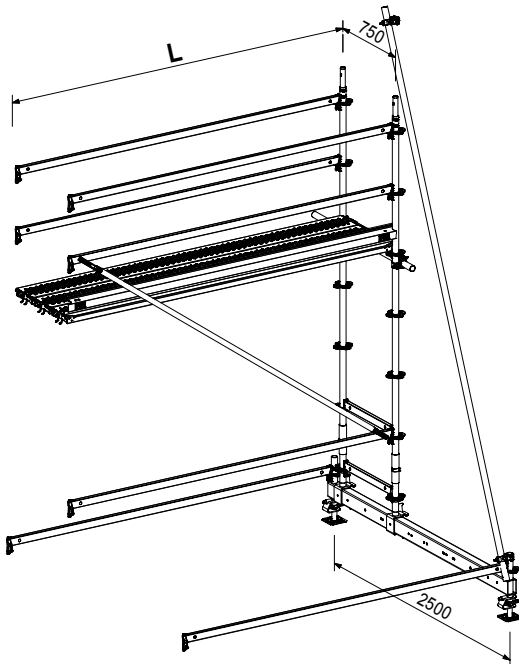

PERI UP Flex Reinforcement Scaffold 75 and 100



Item no.	Weight kg		L
001130	449.856	Reinforcement Scaffold UDI/UDG Basic UVA	
		Reinforce. Scaff. Basic UVA 200 x 250/100	2000
001132	486.826	Reinforce. Scaff. Basic UVA 250 x 250/100	2500
001134	524.426	Reinforce. Scaff. Basic UVA 300 x 250/100	3000

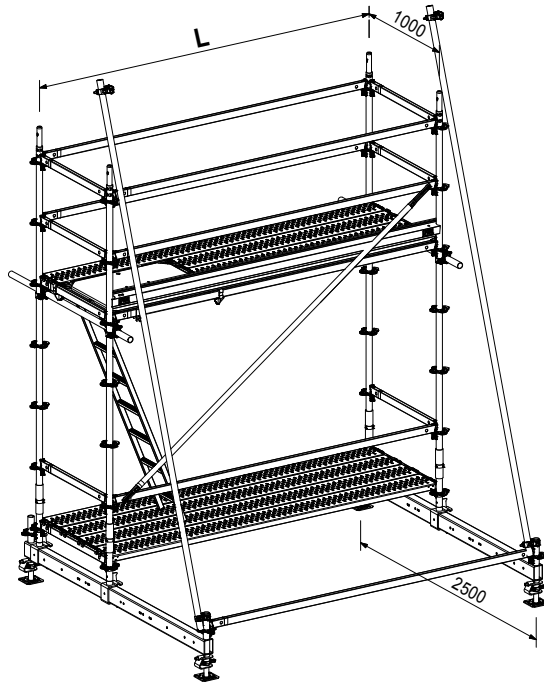

		Reinforcement Scaffold UDI/UDG Add. UVA	L
001136	207.146	Reinforce. Scaff. Add. UVA 150 x 250/100	1500
001131	229.416	Reinforce. Scaff. Add. UVA 200 x 250/100	2000
001133	251.386	Reinforce. Scaff. Add. UVA 250 x 250/100	2500
001135	273.856	Reinforce. Scaff. Add. UVA 300 x 250/100	3000

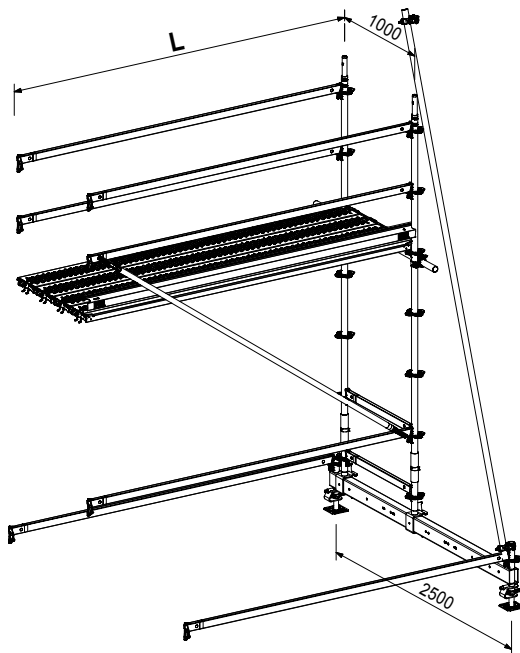

Item no.	Weight kg
100242	4.570

Adj. Base Plate UJB 38-80/55

Note

With captive yellow Quick Jack Nut.

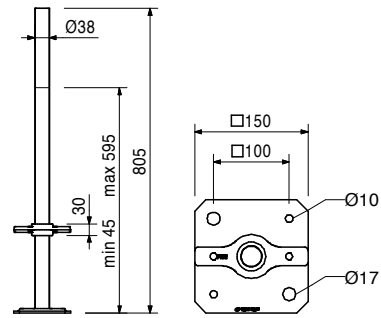
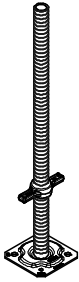

100411	3.390
--------	-------

Adj. Base Plate UJB 38-50/30

Note

With captive red Quick Jack Nut.

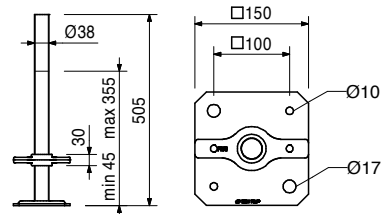

100863	1.020
--------	-------

Spindle Locking UJS

Secures the Adjustable Base Plates and Section Spindles Ø 38 mm in the leg while moving.

Technical Data

Permissible load 1.5 kN.

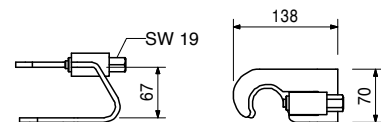

100014	2.470
--------	-------

Base Standard UVB 24

For assembly directly on the base spindle.

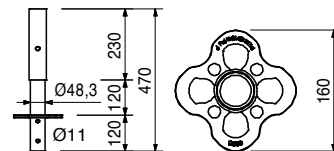

Item no.	Weight kg
100009	10.000
100012	14.700

Standards UVR
Standard UVR 200
Standard UVR 300

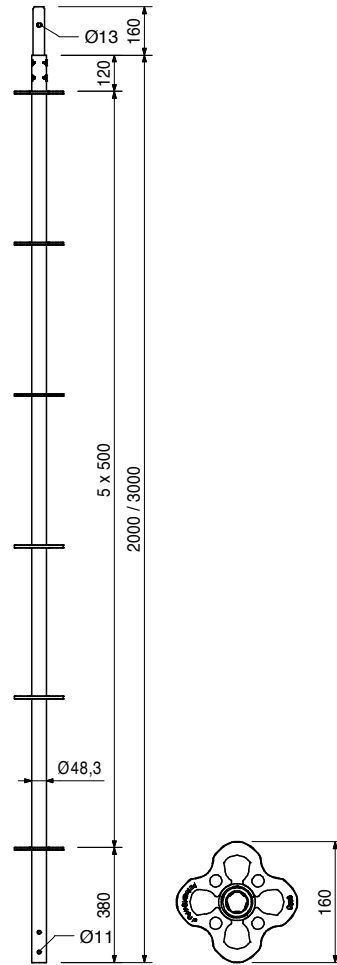
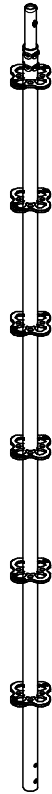

100000	4.610
--------	-------

Top Standard UVH 100
 Without spigot for supporting head spindles.

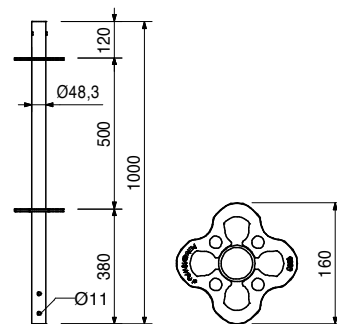

Item no. Weight kg

Item no.	Weight kg	Ledgers UH Plus
114595	2.070	Ledger UH 50 Plus
114629	2.730	Ledger UH 75 Plus
114632	4.390	Ledger UH 100 Plus
114641	4.710	Ledger UH 150 Plus
117032	5.380	Ledger UH 175 Plus
114645	6.040	Ledger UH 200 Plus
114648	7.360	Ledger UH 250 Plus
114651	8.680	Ledger UH 300 Plus

L	X
454	500
704	750
954	1000
1454	1500
1704	1750
1954	2000
2454	2500
2954	3000

Note
Longitudinally-stamped for easier identification.

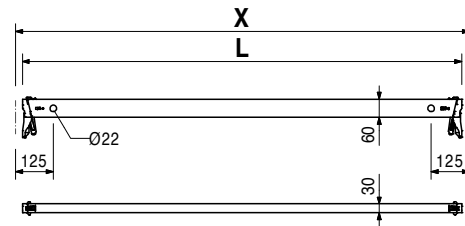
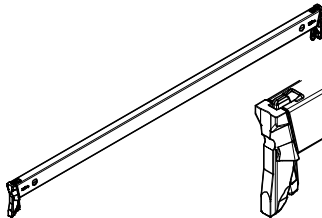

114681	10.900
114691	17.900

Ledger UHV Plus
Ledger UHV 150 Plus
Ledger UHV 250 Plus
For high loads, e.g. material storage.

L	X
1454	1500
2454	2500

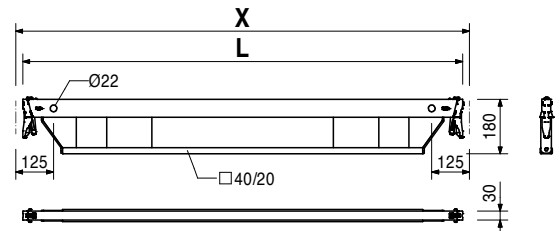
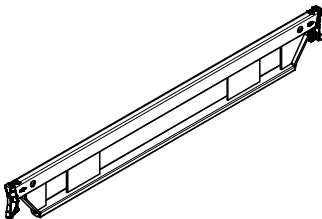

101731	0.841
--------	-------

Ledger to Ledger Coupler UHA
For connecting ledger to ledger at right-angles.

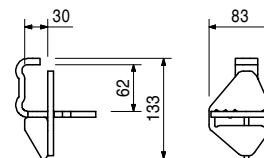

110792	1.900
--------	-------

Ledger to Ledger Coupler UHA Half w. Spigot

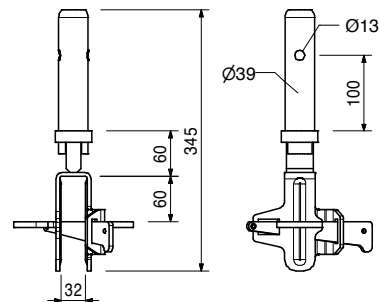
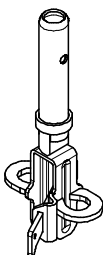

Item no.	Weight kg
100870	40.700

Base Beam UVA 250

For free-standing and mobile scaffold units. For symmetric and antimetric assembly of UPT 72/T 104 and Rosett 72, 75, 100, 104 and symmetric assembly of Rosett b = 75, 100, 150, 200 and 250 cm.

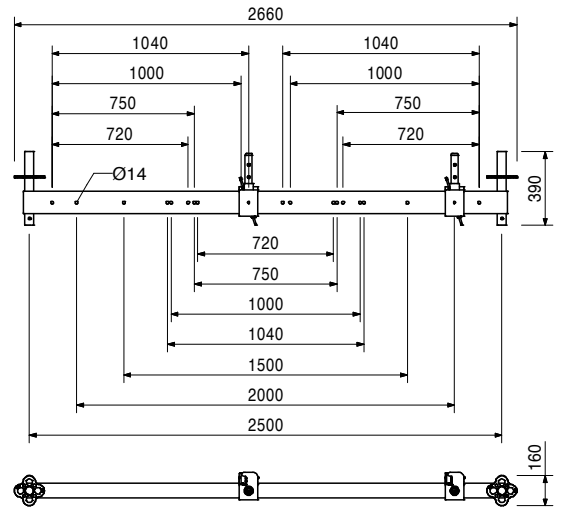
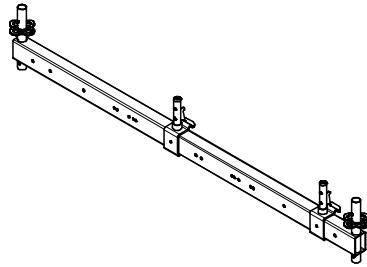

		Ledgers UH
404779	2.040	Ledger UH 50
400017	2.700	Ledger UH 75
401159	3.360	Ledger UH 100
400021	4.690	Ledger UH 150
400023	6.020	Ledger UH 200
400025	7.340	Ledger UH 250
400027	8.670	Ledger UH 300

L	X
454	500
704	750
954	1000
1454	1500
1954	2000
2454	2500
2954	3000

Note

Longitudinally-stamped and with coloured label for easier identification.

Ledgers UH can be replaced by ledgers UH Plus.

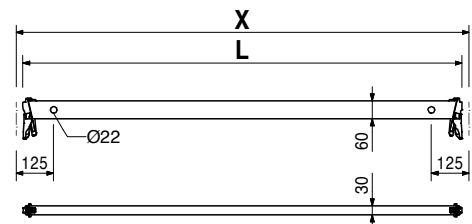
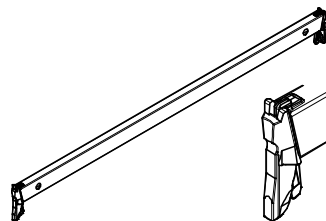

PERI UP Flex Reinforcement Scaffold 75 and 100



Item no.	Weight kg
409107	10.900
409109	18.000

Ledger UHV
Ledger UHV 150
Ledger UHV 250

For high loads, e.g. material storage.

L	X
1454	1500
2454	2500

Note
 Ledgers UHV can be replaced by ledgers UHV Plus.

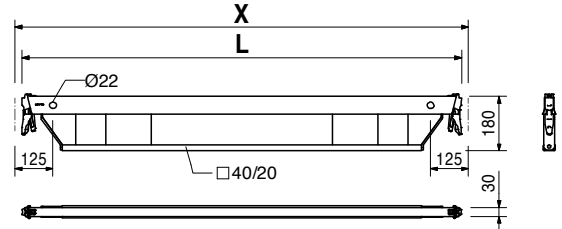
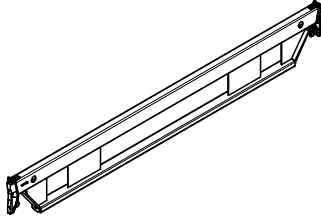

100057	6.380
100061	7.150
100065	8.050
100069	9.040

Ledger Braces UBL
Ledger Brace UBL 150/200
Ledger Brace UBL 200/200
Ledger Brace UBL 250/200
Ledger Brace UBL 300/200

Attach using holes in the ledger.

L	X	Y
2358	1500	2000
2658	2000	2000
3010	2500	2000
3400	3000	2000

Note
 Longitudinally-stamped for easier identification.

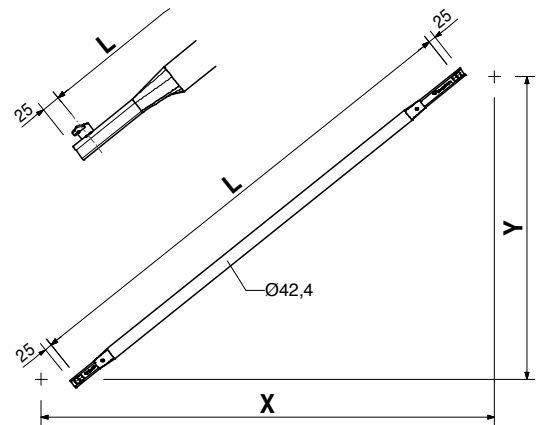
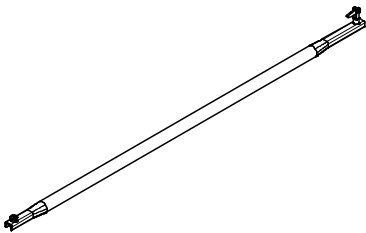

Item no.	Weight kg
100416	9.520

Coupler Brace UBC 150/200

For special applications.
For connecting to Scaffold Tube \varnothing 48 mm.

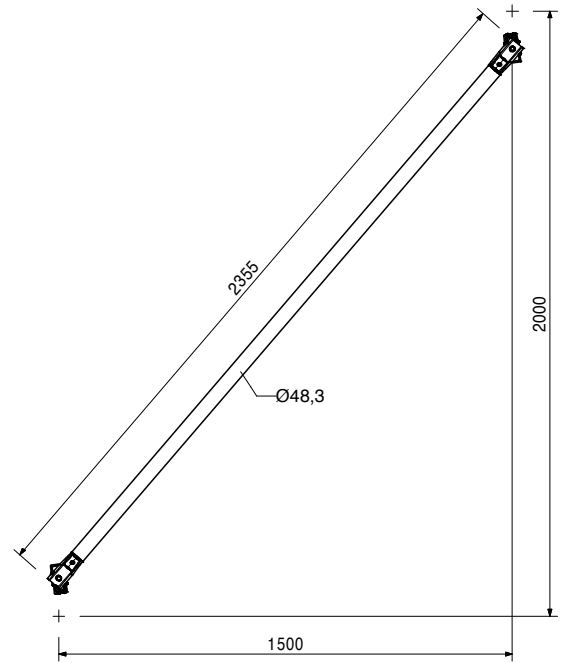
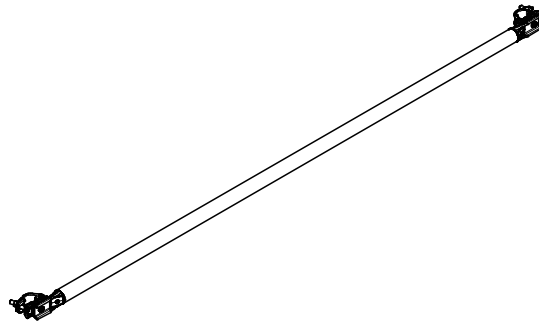

124170	6.770
100572	7.590

Node Brace UBK

Node Brace UBK 75/200

Node Brace UBK 150/200

L	X	Y
2190	750	2000
2539	1500	2000

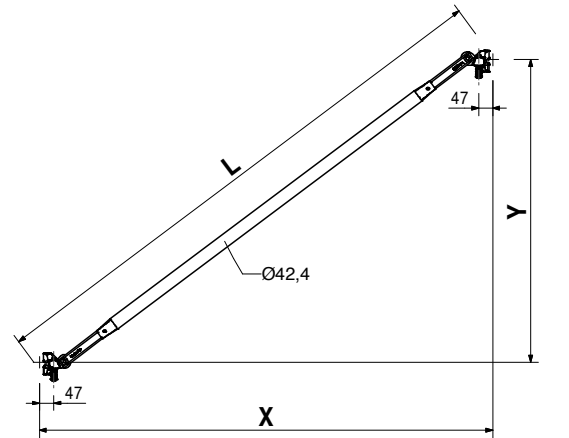
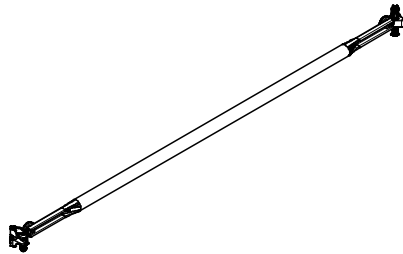

Item no. Weight kg

		Steel Decks UDG 25
124121	5.260	Steel Deck UDG 25 x 75
124118	6.630	Steel Deck UDG 25 x 100
124112	9.410	Steel Deck UDG 25 x 150
124109	12.200	Steel Deck UDG 25 x 200
123771	14.900	Steel Deck UDG 25 x 250
124915	17.700	Steel Deck UDG 25 x 300

Mounted on Ledger UH.

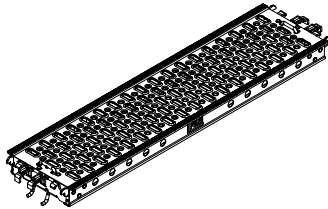

X	perm. p [kN/m ²]	max. p [kN/m ²]
750	6.0	40.0
1000	6.0	40.0
1500	6.0	19.6
2000	6.0	10.9
2500	4.5	6.9
3000	3.0	4.7

Note

perm. p according to DIN EN 12811-1.
max. p = < maximum possible load without deflection limitation.

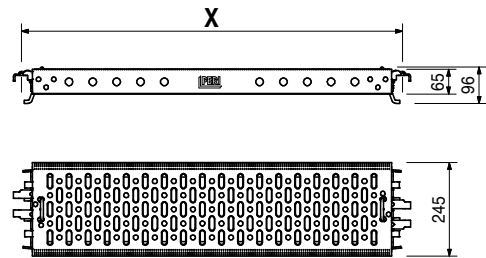

		Industrial Decks UDI 25
105925	5.520	Industrial Deck UDI 25 x 75
106092	6.950	Industrial Deck UDI 25 x 100
107002	9.790	Industrial Deck UDI 25 x 150
108380	12.700	Industrial Deck UDI 25 x 200
108540	15.500	Industrial Deck UDI 25 x 250
108689	18.400	Industrial Deck UDI 25 x 300

Mounted on Ledger UH.

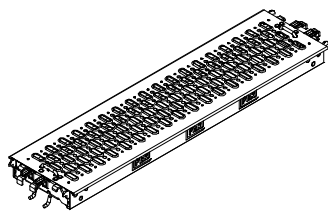

X	perm. p [kN/m ²]	max. p [kN/m ²]
750	6.0	40.0
1000	6.0	40.0
1500	6.0	19.6
2000	6.0	10.9
2500	4.5	6.9
3000	3.0	4.7

Note

perm. p according to DIN EN 12811-1.
max. p = < maximum possible load without deflection limitation.

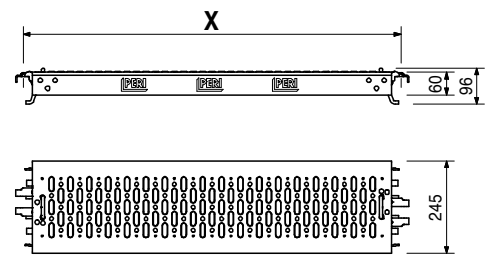

PERI UP Flex Reinforcement Scaffold 75 and 100



Item no.	Weight kg
126393	15.600
126392	19.600
126314	23.500

Access Decks UAL-3
Access Deck UAL-3, 75 x 150/3
Access Deck UAL-3, 75 x 200/3
Access Deck UAL-3, 75 x 250/3

L
1500
2000
2500

Technical Data
 Load Class 3, 2.0 kN/m².

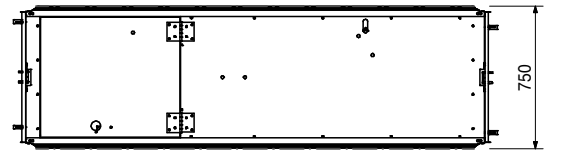
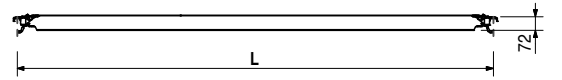
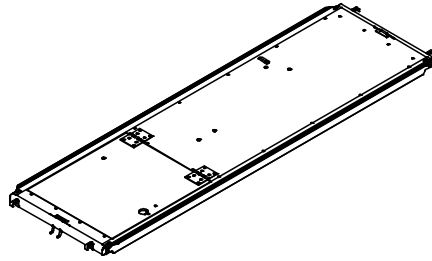

Accessories

126318	3.750
--------	-------

Ladder Flex UEL with hook

126318	3.750
--------	-------

Ladder Flex UEL with hook

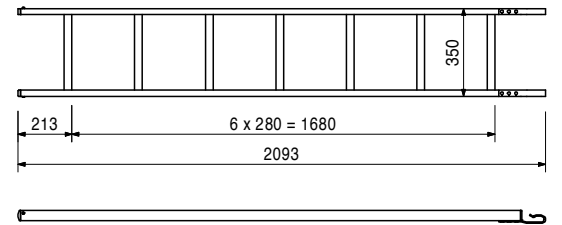
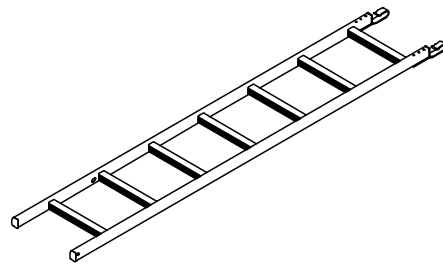

109755	15.600
--------	--------

Hatch UAF 75 x 100

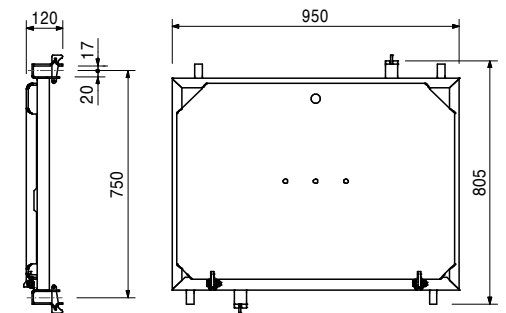
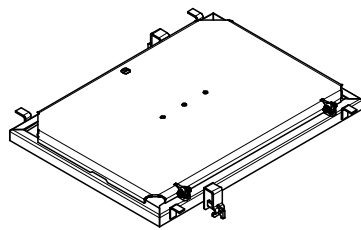

Accessories

109879	3.820
--------	-------

Ladder UAF 200, Alu

PERI UP Flex Reinforcement Scaffold 75 and 100



Item no.	Weight kg
109879	3.820

Ladder UAF 200, Alu
For mounting to Hatch UAF.

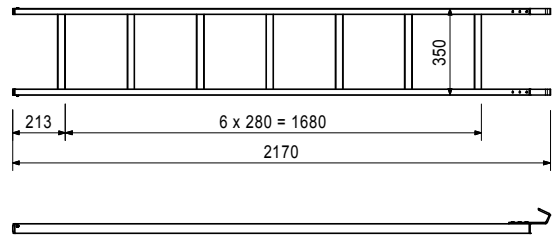
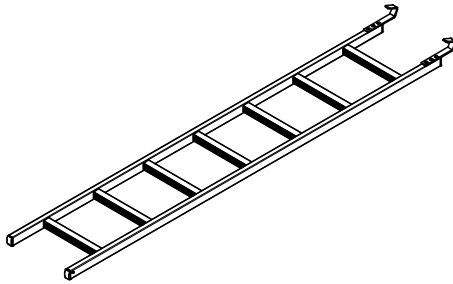

Item no.	Weight kg
129498	3.320
129500	4.390
129502	5.460
129504	6.520

Toeboards Wood UPF
Toeboard Wood UPF 150
Toeboard Wood UPF 200
Toeboard Wood UPF 250
Toeboard Wood UPF 300

L	X
1495	1500
1995	2000
2495	2500
2995	3000

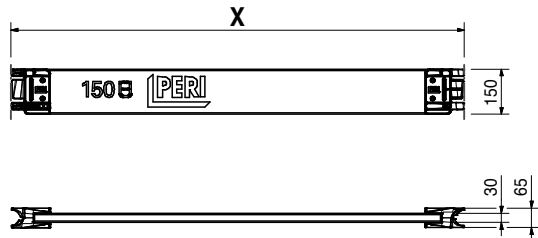
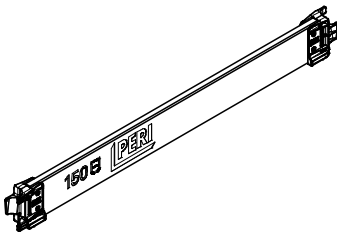

Item no.	Weight kg
110160	3.000
110176	4.030
110208	5.060
110211	6.100

Toeboards Steel UPY
Toeboard Steel UPY 150
Toeboard Steel UPY 200
Toeboard Steel UPY 250
Toeboard Steel UPY 300

L	X
1486	1500
1986	2000
2486	2500
2986	3000

Note

- Standard: Surface galvanized and yellow painted.
- Individual design of the Toeboards regarding colouring and imprint possible on request

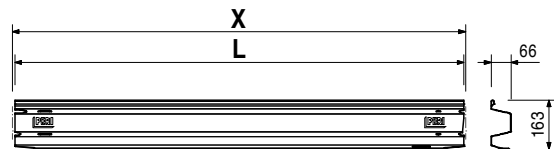
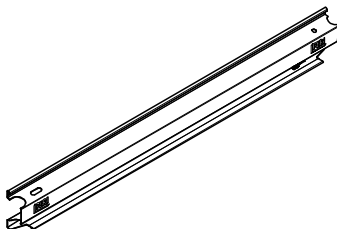

PERI UP Flex Reinforcement Scaffold 75 and 100



Item no.	Weight kg
123694	3.000
123696	4.030
123698	5.060
123700	6.100

Toeboards Steel UPY, galv.
Toeboard Steel UPY 150, galv.
Toeboard Steel UPY 200, galv.
Toeboard Steel UPY 250, galv.
Toeboard Steel UPY 300, galv.

L	X
1486	1500
1986	2000
2486	2500
2986	3000

Note
 Surface: galvanized.

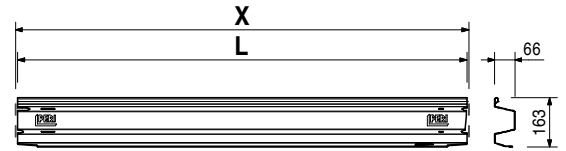
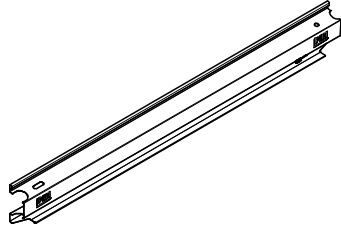

130577	6.500
130583	7.600

Advance Guardrails UPA
Advance Guardrail UPA 75
Advance Guardrail UPA 100

L	X
881	750
1131	1000

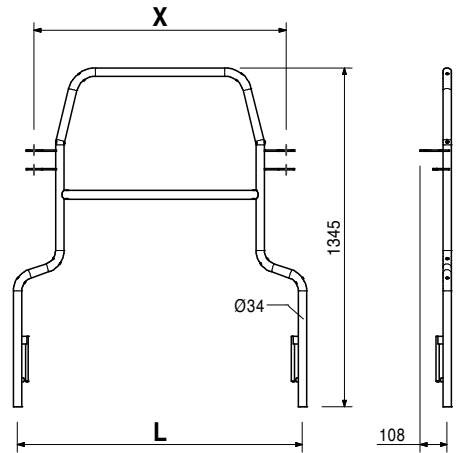
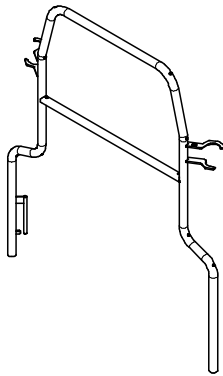

130562	0.623
--------	-------

Guardrail Holder EPW
 For mounting Guardrails EPG to the rosettes.

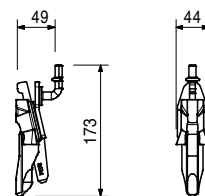
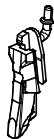

Item no.	Weight kg		L	X
130195	2.480	Guardrails EPG	1565	1500
130197	3.280	Guardrail EPG 150	2065	2000
130199	4.090	Guardrail EPG 200	2565	2500
130201	4.890	Guardrail EPG 300	3065	3000

Note
Longitudinally-stamped for easier identification.

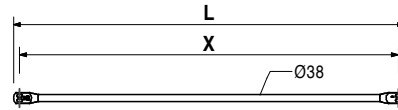
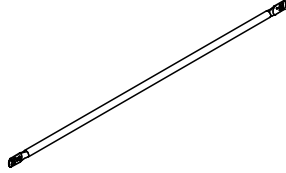

017010	1.400	Swivel Coupling DK 48/48, galv. For Scaffold Tubes Ø 48 mm.
--------	-------	---

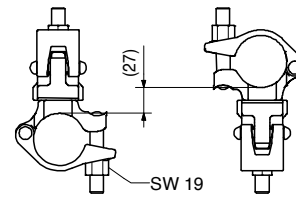
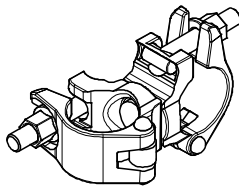

017000	1.540	Swivel Coupling DK 60/48, galv. For Scaffold Tubes Ø 48 mm and Ø 60 mm.
--------	-------	---

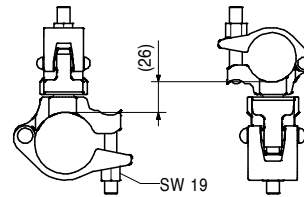
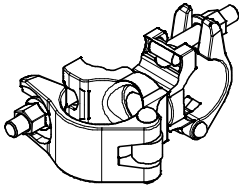

017020	1.120	Standard Coupler NK 48/48, galv. For Scaffold Tubes Ø 48 mm.
--------	-------	--

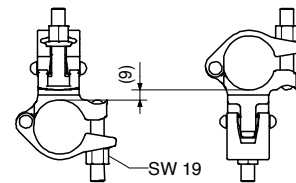
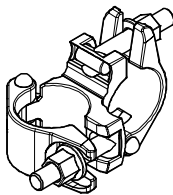

026412	7.100	Scaff. Tubes Steel Ø 48.3 x 3.2, l	L
026419	17.750	Scaff. Tube Steel Ø 48.3 x 3.2, l = 2.0 m	2000
		Scaff. Tube Steel Ø 48.3 x 3.2, l = 5.0 m	5000

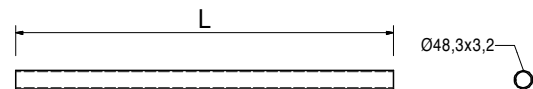
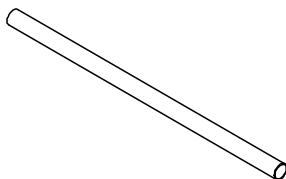

Item no.	Weight kg
111053	0.059

Locking Pin Ø 48/57

As tension-proof connection of standards with a diameter of 48 up to 57 mm.

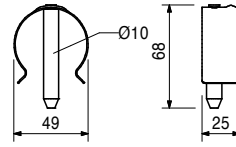

100719	0.060
--------	-------

Bolt ISO 4014 M10 x 70-8.8 MU

As tension-proof connection of standards for suspended scaffolds or lattice girders.

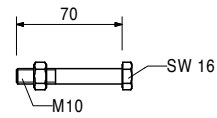
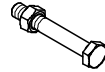

111117	28.000
--------	--------

Staircase UAS 75 x 250/200, Alu

Assembly on Ledgers UH.

Technical Data

Permissible load 2.0 kN/m².

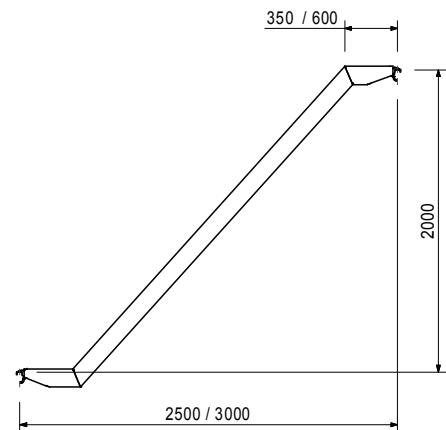
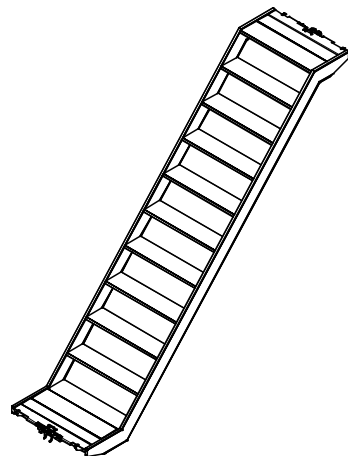

Item no.	Weight kg
100742	10.000

Stair Guardrail UAG

Suitable for Staircases UAS 64 x 250/200, UAS 64 x 300/200, UAS 75 x 250/200 and UAS 75 x 300/200 as internal and external guardrail.

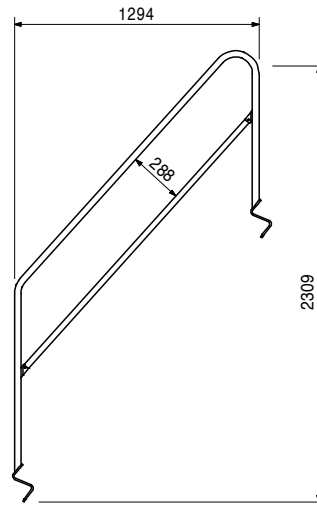
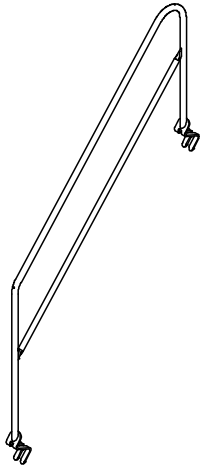

100830	4.970
--------	-------

Stair Guardrail UAH

For fixing to the stringers of the Staircase Units UAS 64 x 250/200, UAS 64 x 300/200, UAS 75 x 250/200, UAS 75 x 300/200.

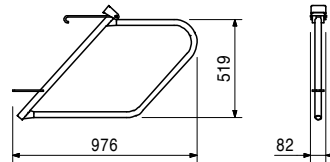
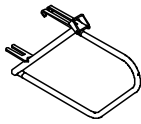

100265	2.410	Guardrails UPG
100266	3.220	Guardrail UPG 150
100267	4.020	Guardrail UPG 200
100268	4.820	Guardrail UPG 250
		Guardrail UPG 300

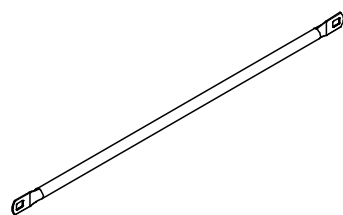

L	X
1546	1500
2046	2000
2546	2500
3046	3000

Note

Longitudinally-stamped and with coloured label for easier identification.

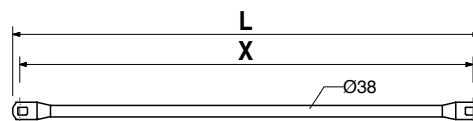

Item no.	Weight kg
113832	0.035

PERI UP Scaffold Tag

To cordon off scaffolding areas not yet authorized for use. With the exception of inserting the PERI UP Assembly Certificate.



Neue Gruppe	
113833	0.005
113834	0.005
113829	0.005
113835	0.005
113836	0.005
113837	0.005
113838	0.005
113839	0.005
115739	0.005
115729	0.005
125180	0.005
124052	0.005
124645	0.005
117692	0.005
126647	0.005

Inserted into the PERI UP Scaffold Tag.

Note

Front side:
Assembly report for release of scaffolding.
Rear side:
Test report

Inspection Record		
Inspection by qualified person only		
Important Any modifications made to the scaffold, e.g. removal of anchors, may only be carried out by the scaffolder.		
Date	Time	Signature
Scaffold is no longer authorized for use:		
Date: _____		

Assembly Certificate	
To be completed by the supervisor	
Installation location _____	
Client _____	
Scaffolder _____	
Date _____	
Signature _____	
Working scaffold according to EN 12811, for Load Class	
<input type="checkbox"/> W05 0.6	<input type="checkbox"/> kN/m ²
Width Class W	
<input type="checkbox"/> W05 0.6	w = 0.5 m
<input type="checkbox"/> W05 0.9	w = 1.2 m
<input type="checkbox"/> W12 0.24	w = 1.2 m
Handing-Over Certificate	
To be completed by the inspecting person	
Name _____	
Signature _____	
Date, Time _____	
Remarks _____	

Comparison of components

As part of ongoing product optimisation, the following components have been replaced by 2nd generation components.

The following comparison tables describe the features of the 1st and 2nd generation.



1st and 2nd generation components can be combined.

- The previous components are no longer available as new components.
- The optimised components are available under a new article number.
- There may be a difference between the load-bearing capacity of the individual components in the previous version and the new version.

Base Standard UVB 24 / 49

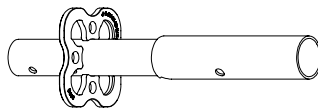

Base Standard UVB 25 / 50

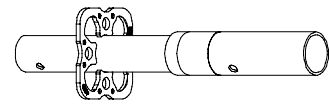

Tube	RO 48.3 mm x 3.6 mm	RO 48.3 mm x 3.6 mm
Rosette	160 mm x 130 mm x 8 mm	152 mm x 120 mm x 6 mm
System height	24 / 49 cm	25 / 50 cm
Combinability	Geometrically and statically combinable in the system.	

Standard UVR

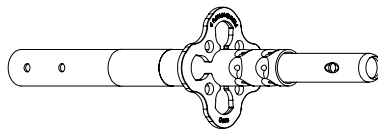

Standard UVR-2

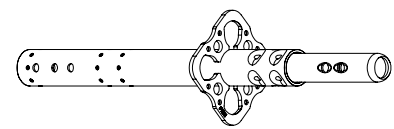

Tube	RO 48.3 mm x 3.2 mm	RO 48.3 mm x 2.7 mm , embossed points on the bottom standard.
Tube-pin connection	2 rows, with 5 pinch points each	2 rows, with 4 pinch points each
Rosette	160 mm x 130 mm x 8 mm	152 mm x 120 mm x 6 mm
Hole for suspended scaffold (see "PERI UP components")	1 hole perm. F up to 20 kN when fixed 1x	2 holes perm. F up to 15 kN when fixed 1x perm. F up to 31 kN when fixed 2x
Marking	none	striped band at the top and bottom
Combinability	Geometrically and statically* combinable in the system. * The standard configurations in the Instructions for Assembly and Use only apply in conjunction with Horizontal Ledgers UH Plus / UH-2 and UHV Plus / UHV-2. * The load tables shown in the Instructions for Assembly and Use for the Heavy-Duty Prop HD and Shoring Tower Plus systems do not apply to use of the Standard UVR-2. Check the statics beforehand!	

Top Standard UVH

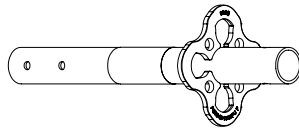

Top Standard UVH-2

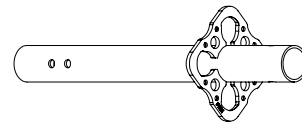

Tube	RO 48.3 mm x 3.2 mm	RO 48.3 mm x 3.2 mm
Rosette	160 mm x 130 mm x 8 mm	152 mm x 120 mm x 6 mm
Hole for suspended scaffold (see "PERI UP components")	1 hole perm. F up to 20 kN when fixed 1x	2 holes perm. F up to 15 kN when fixed 1x perm. F up to 31 kN when fixed 2x
Combinability	Geometrically and statically combinable in the system.	

Horizontal Ledger UH Plus

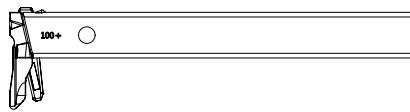

Horizontal Ledger UH-2

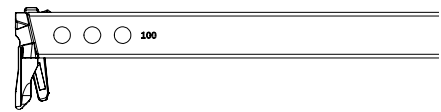

UBL assembly points	2 x 1, for assembly of a Ledger Brace UBL	2 x 3, for assembly of up to three Ledger Braces UBL When installing only one ledger brace preferably use the middle assembly point. Ledger Braces UBL can be mounted at very flat installation angles using the middle assembly point only. Check the geometry beforehand!
Combinability	Geometrically and statically combinable in the system.	

Horizontal Ledger UHV Plus

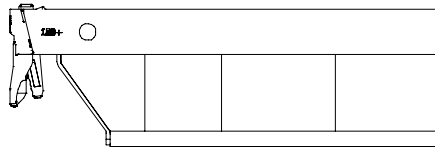

Horizontal Ledger UHV-2

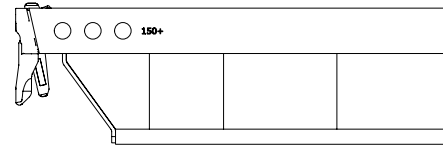

UBL assembly points	2 x 1, for assembly of a Ledger Brace UBL	2 x 3, for assembly of up to three Ledger Braces UBL When installing only one ledger brace preferably use the middle assembly point. Ledger Braces UBL can be mounted at very flat installation angles using the middle assembly point only. Check the geometry beforehand!
Combinability	Geometrically and statically combinable in the system.	

Steel Deck UDG

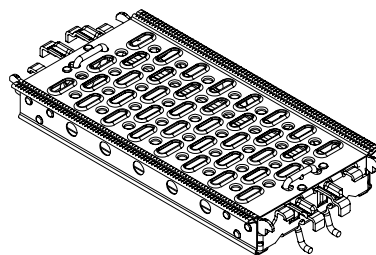

Steel Deck UDG-2

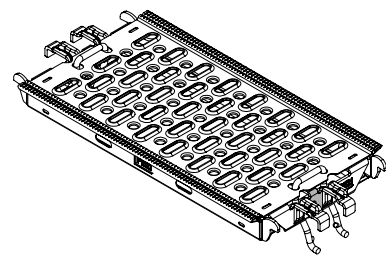

Deck assembly	riveted and welded	welded
Profile height	65 mm, uniform	L 50 – 150: 45 mm L 200 – 250: 60 mm L 300: 70 mm
Marking	without	coloured clip on the front side
Combinability	Geometrically and statically combinable in the system.	

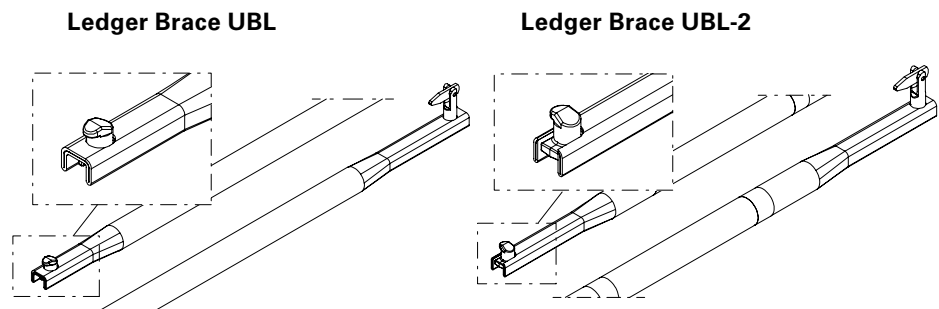

UBL Mounting Lug	points in the longitudinal direction	points in the transverse direction
Combinability	Geometrically and statically combinable in the system.	
Marking	none	Band at the top and bottom
Handling	Tilt in to install.	Swivel in to install (less lateral space required for installation).

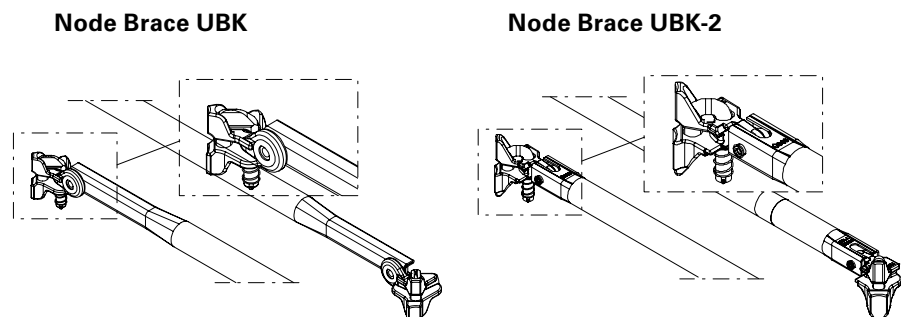

Head piece connected to the diagonal tube	riveted to crimped tube	bolted to cast shaped component
Combinability	Geometrically and statically combinable in the system.	
Marking	none	Band at the top and bottom
Features	Galvanised heads	Yellow-coated heads

Article no. Weight kg

133499 2.270 **Base Standard UVB 25**

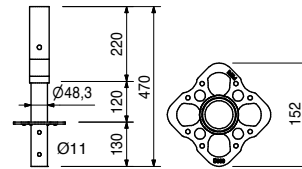
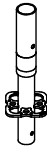

135187 3.590 **Base Standard UVB 50**

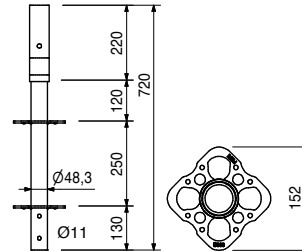

132219	2.480	Standard UVR-2
132224	4.340	Standard UVR-2 50
132229	6.180	Standard UVR-2 100
132234	8.030	Standard UVR-2 150
132239	11.700	Standard UVR-2 200
		Standard UVR-2 300

L
500
1,000
1,500
2,000
3,000

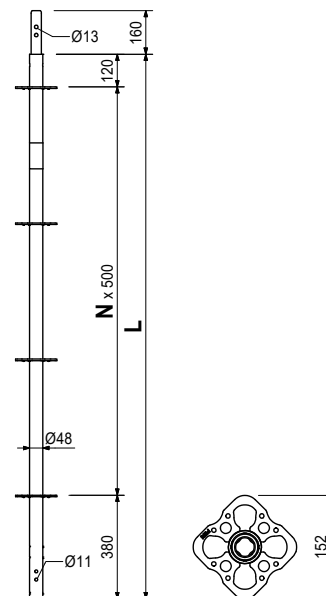
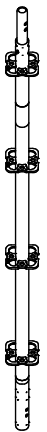

132196 6.060 **Top Standard UVH-2 125**
Without pin for supporting head spindles. Reduces necessary spindle extensions with 25 cm rosette spacing.

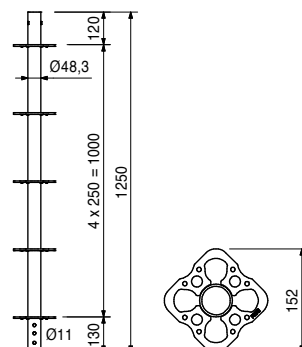
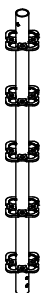

Article no. Weight kg

132123	2.090
132194	4.210
132198	6.310
132200	8.420
100002	10.500

Top Standards UVH-2
Top Standard UVH-2 50
Top Standard UVH-2 100
Top Standard UVH-2 150
Top Standard UVH-2 200
Top Standard UVH-2 250

Without pin for supporting head spindles.



L
500
1,000
1,500
2,000
2,500

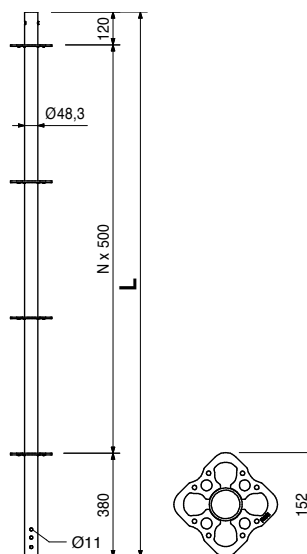

132479	3.340
132483	4.100
132488	4.470
132492	5.590
132502	6.730
132505	7.870
132508	10.500
132511	12.900
132515	15.800

Steel Decks UDG-2 25
Steel Deck UDG-2 25X 50
Steel Deck UDG-2 25X 67
Steel Deck UDG-2 25X 75
Steel Deck UDG-2 25X100
Steel Deck UDG-2 25X125
Steel Deck UDG-2 25X150
Steel Deck UDG-2 25X200
Steel Deck UDG-2 25X250
Steel Deck UDG-2 25X300

X	perm. p [kN/m ²]	H
500	6.0	45
670	6.0	45
750	6.0	45
1,000	6.0	45
1,250	6.0	45
1,500	6.0	45
2,000	6.0	60
2,500	4.5	60
3,000	3.0	70

Note

Values correspond with EN 12811-1

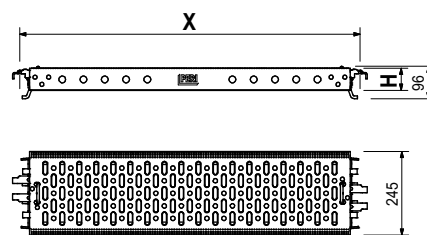
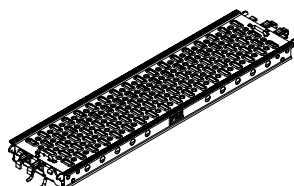

137020	9.410
137025	12.700
137030	15.200
137035	18.500

Horizontal Ledger UHV-2
Horizontal Ledger UHV-2 150
Horizontal Ledger UHV-2 200
Horizontal Ledger UHV-2 250
Horizontal Ledger UHV-2 300

For high loads, e.g. in the case of material storage.

L	X
1,454	1,500
1,954	2,000
2,454	2,500
2,954	3,000

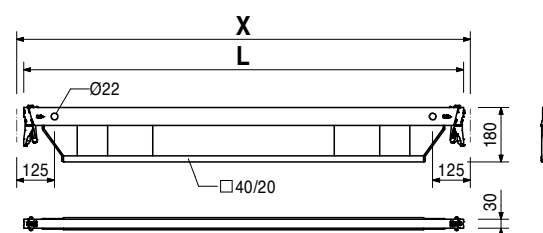
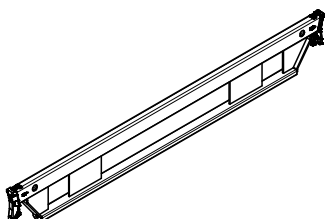

Article no. Weight kg

Article no.	Weight kg	Horizontal Ledger UH-2
131995	1.40	Horizontal Ledger UH-2 25
133900	1.50	Horizontal Ledger UH-2 33
131998	2.03	Horizontal Ledger UH-2 50
133903	2.48	Horizontal Ledger UH-2 67
132213	2.69	Horizontal Ledger UH-2 75
132004	3.79	Horizontal Ledger UH-2 100
132007	4.58	Horizontal Ledger UH-2 125
132010	4.68	Horizontal Ledger UH-2 150
132013	5.34	Horizontal Ledger UH-2 175
132016	6.00	Horizontal Ledger UH-2 200
132019	6.66	Horizontal Ledger UH-2 225
132025	7.32	Horizontal Ledger UH-2 250
132022	8.65	Horizontal Ledger UH-2 300

L	X
204	250
284	330
454	500
624	670
704	750
954	1,000
1,204	1,250
1,454	1,500
1,704	1,750
1,954	2,000
2,204	2,250
2,454	2,500
2,954	3,000

Note

With length marking for easier identification.

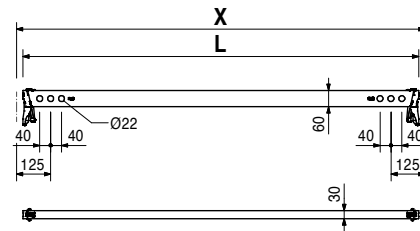
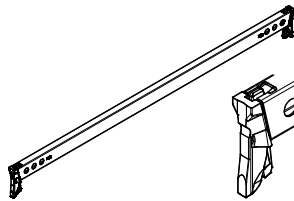

Article no.	Weight kg	Node Brace UBK-2
133418	4.96	Node Brace UBK-2 75/200
133421	5.11	Node Brace UBK-2 100/200
133424	3.88	Node Brace UBK-2 125/100
133427	5.30	Node Brace UBK-2 125/200
133430	4.22	Node Brace UBK-2 150/100
133433	4.82	Node Brace UBK-2 150/150
133436	5.53	Node Brace UBK-2 150/200
133439	4.97	Node Brace UBK-2 200/100
133442	5.47	Node Brace UBK-2 200/150
133445	6.08	Node Brace UBK-2 200/200
133448	5.77	Node Brace UBK-2 250/100
133451	6.19	Node Brace UBK-2 250/150
133454	6.72	Node Brace UBK-2 250/200
133457	6.60	Node Brace UBK-2 300/100
133460	6.96	Node Brace UBK-2 300/150
133463	7.42	Node Brace UBK-2 300/200

L	X	Y
2,190	750	2,000
2,285	1,000	2,000
1,625	1,250	1,000
2,401	1,250	2,000
1,821	1,500	1,000
2,152	1,500	1,500
2,539	1,500	2,000
2,246	2,000	1,000
2,521	2,000	1,500
2,860	2,000	2,000
2,696	2,500	1,000
2,930	2,500	1,500
3,226	2,500	2,000
3,131	3,000	1,000
3,356	3,000	1,500
3,625	3,000	2,000

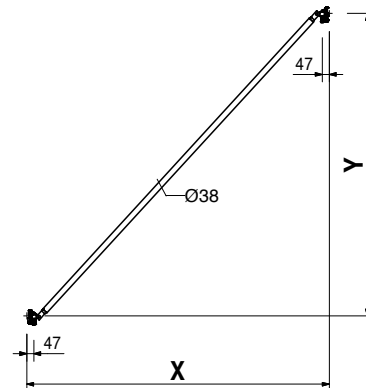
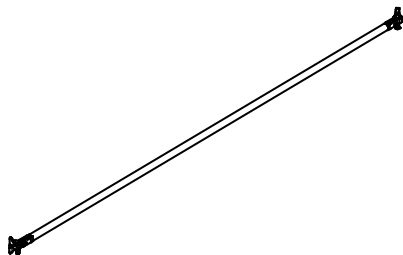

Article no. Weight kg

Article no.	Weight kg		L	X	Y
		Ledger Braces UBL-2			
132771	2.12	Ledger Brace UBL-2 100/ 50	901	1,000	500
132773	2.81	Ledger Brace UBL-2 100/100	1,250	1,000	1,000
132775	3.66	Ledger Brace UBL-2 100/150	1,677	1,000	1,500
132777	4.58	Ledger Brace UBL-2 100/200	2,136	1,000	2,000
132779	3.01	Ledger Brace UBL-2 150/ 50	1,347	1,500	500
132781	3.51	Ledger Brace UBL-2 150/100	1,601	1,500	1,000
132783	4.21	Ledger Brace UBL-2 150/150	1,953	1,500	1,500
132785	5.02	Ledger Brace UBL-2 150/200	2,358	1,500	2,000
132787	5.31	Ledger Brace UBL-2 175/200	2,500	1,750	2,000
132789	3.95	Ledger Brace UBL-2 200/ 50	1,820	2,000	500
132791	4.34	Ledger Brace UBL-2 200/100	2,016	2,000	1,000
132793	4.92	Ledger Brace UBL-2 200/150	2,305	2,000	1,500
132795	5.62	Ledger Brace UBL-2 200/200	2,658	2,000	2,000
132797	4.43	Ledger Brace UBL-2 225/ 50	2,062	2,250	500
132808	4.78	Ledger Brace UBL-2 225/100	2,236	2,250	1,000
132810	5.96	Ledger Brace UBL-2 225/200	2,829	2,250	2,000
132812	5.23	Ledger Brace UBL-2 250/100	2,462	2,500	1,000
132814	5.71	Ledger Brace UBL-2 250/150	2,705	2,500	1,500
132816	6.32	Ledger Brace UBL-2 250/200	3,010	2,500	2,000
132827	5.90	Ledger Brace UBL-2 300/ 50	2,795	3,000	500
132829	6.16	Ledger Brace UBL-2 300/100	2,926	3,000	1,000
132831	6.57	Ledger Brace UBL-2 300/150	3,133	3,000	1,500
132833	7.10	Ledger Brace UBL-2 300/200	3,400	3,000	2,000

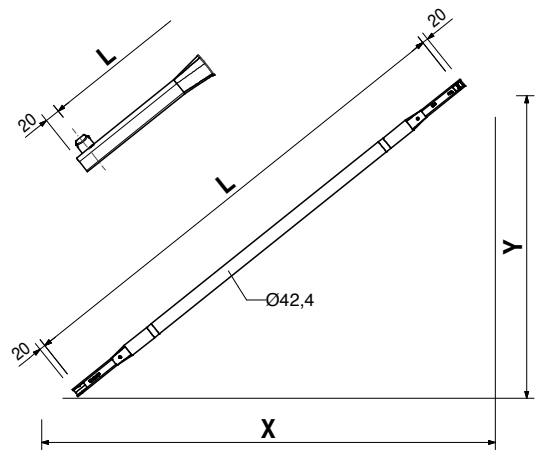
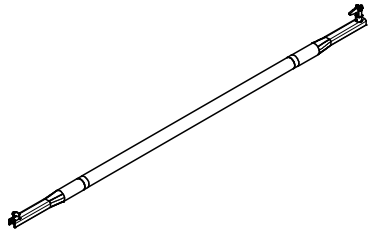

**The optimal System
for every Project and
every Requirement**



Wall Formwork



Column Formwork



Slab Formwork



Climbing Systems

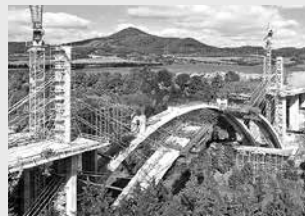

Bridge Formwork



Tunnel Formwork



Shoring Systems



Construction Scaffold



Facade Scaffold



Industrial Scaffold



Access



Protection Scaffold



Safety Systems



**System-Independent
Accessories**



Services



PERI GmbH
Formwork Scaffolding Engineering
 Rudolf-Diesel-Strasse 19
 89264 Weissenhorn
 Germany
 Tel. +49 (0)7309.950-0
 Fax +49 (0)7309.951-0
 info@peri.com
 www.peri.com

