

TRIO – TRS90 / TRS120

Column Formwork

Instructions for Assembly and Use – Standard Configuration – Issue 04/2018

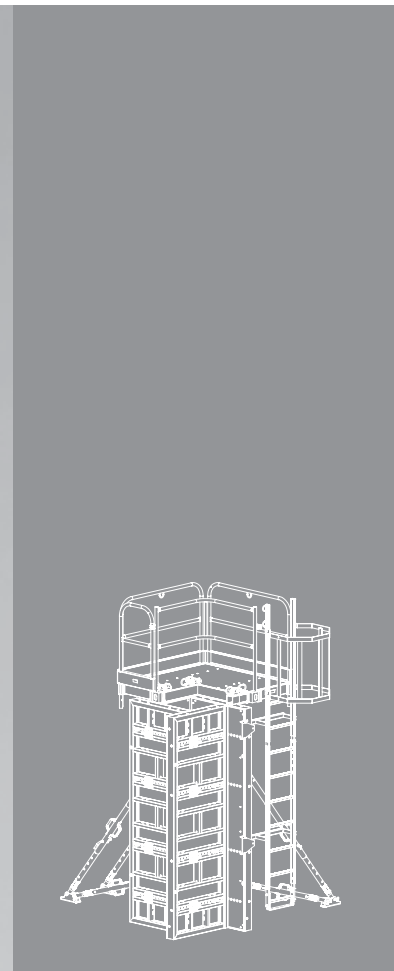
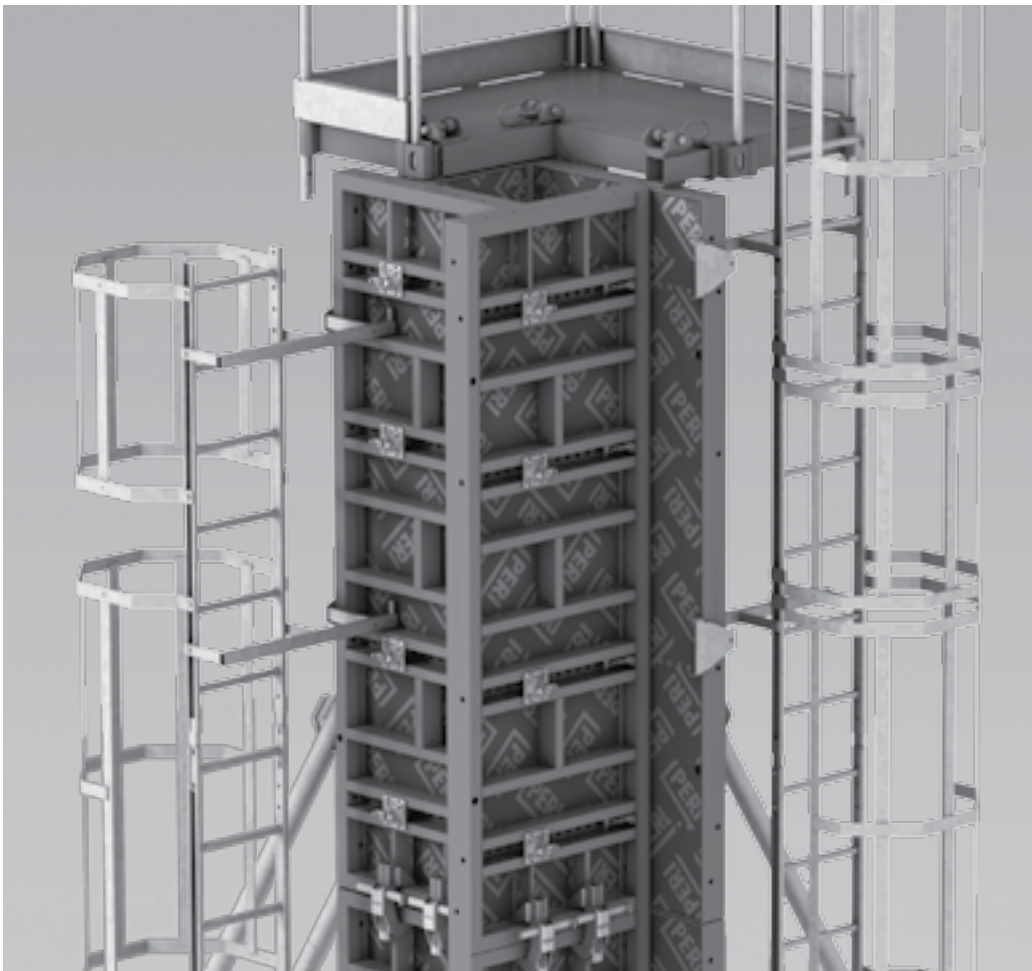

Main components

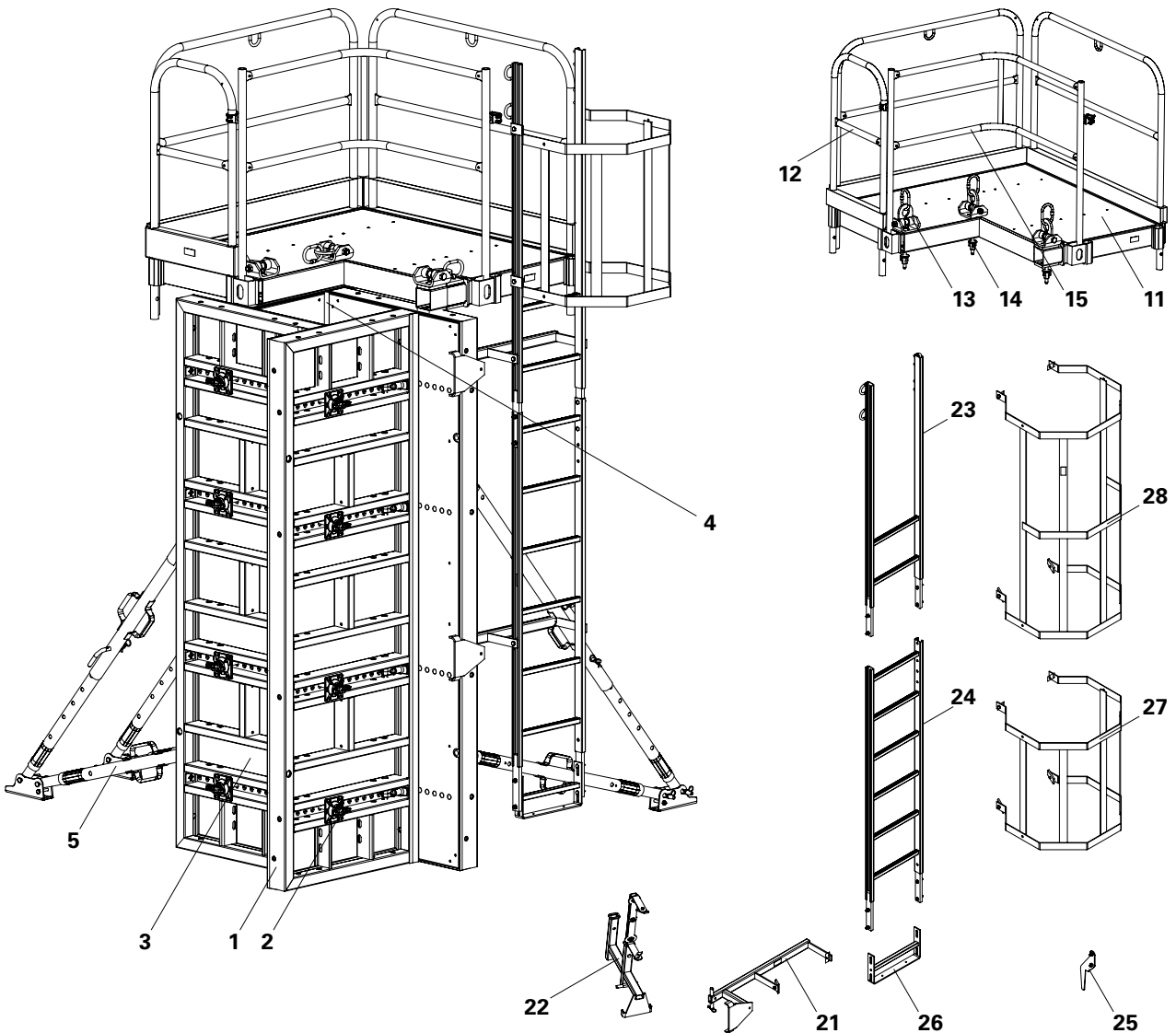

TRIO Column

- 1 Column Panel TRS90 / TRS120
- 2 Corner Connection
- 3 Formlining
- 4 Chamfer Strip
- 5 Push-Pull Props RS / RSS with Kickers

Concreting Platform

- 11 Concreting Landing
- 12 Guardrail 134 or 52
- 13 Crane Eye (load-bearing point)
- 14 Cam Nut DW 15
- 15 Front Guardrail Landing 86/86

Ladder Access

- 21 Ladder Connector TRIO (only for TRS90)
- 22 Ladder Connector TRIO [NEW] (for TRS90 and TRS120)
- 23 End Ladder 180/2
- 24 Ladder 180/6
- 25 Ladder Hook
- 26 Ladder Base
- 27 Ladder Safety Cage 75
- 28 Ladder Safety Cage 150

Overview	
Main components	3
Key	4
Presentational reference	4
Introduction	
Target groups	5
Additional technical documentation	5
Standard configuration	6
Intended use	6
Instructions on use	6
Cleaning and maintenance instructions	7
Safety instructions	
Cross-system	7
System-specific	9
Storage and transportation	9
Assembly and dismantling	
A1 Storage and transportation	
Panels and accessories	10
A2 Maintenance and cleaning	
Tips and information	11
A3 Assembly	
Formwork halves	12
Push-Pull Props	13
Concreting platform	14
Ladder access for Column Panel TRS90	15
Ladder access for Column Panel TRS90-120	16
Parts list for access ladders	18
A4 Shuttering	
Placing the formwork	20
Closing the formwork	21
A5 Striking and moving	
Striking, moving	22
A6 Height extensions	
Height adjustment up to 8.10 m	23
Components	
TRIO Column Formwork	24

Key

Pictogram | Definition

 Safety instructions

 Information

 Load-bearing point

 Visual check

 Tip

 Safety shoes

 Safety gloves

 Misapplication

Dimension specifications

Dimensions are usually given in cm. Other units of measure, e.g. m, are shown in the illustrations.

Conventions

- Instructions are numbered with: 1., 2., 3.
- The result of an instruction is shown by: →
- Position numbers are clearly provided for the individual components and are given in the drawing, e.g. **1**, in the text in brackets, for example (1).
- Multiple position numbers, i.e. alternative components, are represented with a slash, e.g. **1 / 2**.

Arrows

→ Arrow representing an action

Presentational reference

The illustration on the front cover of these instructions is understood to be a system representation only. The assembly steps presented in these Instructions for Assembly and Use are shown in the form of examples with only one component size. They are valid accordingly for all component sizes contained in the standard configuration.

For a better understanding, detailed illustrations are partly incomplete. Safety installations which have possibly not been included in these detailed drawings must nevertheless still be available.

Target groups

Contractors

These Instructions for Assembly and Use are designed for contractors who either

- assemble, modify and dismantle the formwork systems, or
- use them e.g. for concreting or
- allow them to be used for other work operations, e.g. carpentry or electrical work.

Competent person

(Construction Site Coordinator)

The Safety and Health Protection Coordinator*

- is appointed by the client,
- must identify potential hazards during the planning phase,
- determines measures that provide protection against risks,
- creates a safety and health plan,
- coordinates the protective measures for the contractor and site personnel so that they do not endanger each other,
- monitors compliance with the protective measures.

Competent person qualified to carry out inspections

Due to the specialist knowledge gained from professional training, work experience and recent professional activity, the competent person qualified to carry out inspections has a reliable understanding of safety-related issues and can correctly carry out inspections. Depending on the complexity of the inspection to be undertaken, e.g. scope of testing, type of testing or the use of certain measuring devices, a range of specialist knowledge is necessary.

Qualified persons

Formwork systems may only be assembled, modified or dismantled by personnel who are suitably qualified to do so. For the work to be carried out, the qualified persons must have received instructions** covering at least the following points:

- Explanation of the plan for the assembly, modification or dismantling of the formwork in an understandable form and language.
- Description of the measures for assembling, modifying or dismantling the formwork.

- Designation of the preventive measures to avoid the risk of persons and objects falling.
- Designation of the safety precautions in the event of changing weather conditions which could adversely affect the safety of the formwork system as well as the persons concerned.
- Details regarding the permissible loads.
- Description of any other risks that are associated with the assembly, modification or dismantling procedures.



- **In other countries, ensure that the relevant national guidelines and regulations in the respective current version are complied with!**
- **If no country-specific regulations are available, it is recommended to proceed according to German guidelines and regulations.**
- **A competent person must be present on site during formwork operations.**

* Valid in Germany: Regulations for Occupational Health and Safety on Construction Sites 30 (RAB 30)

** Instructions are given by the contractor himself or a competent person selected by him.

Additional technical documentation

- Instructions for Use:
 - Lifting Hook MAXIMO 1.5 t
 - Pallets and Stacking Devices
- Brochure: TRIO

Standard configuration

General

PERI TRIO Column Formwork TRS90 and TRS120 complements PERI TRIO Wall Formwork. Column Panels TRS are provided with anchor holes in the frame and can be used as 90 cm or 120 cm wide wall panels. The panel frame is powder-coated thus ensuring easy and simple cleaning. Extended column panels are connected at the joints by means of the Alignment Coupler BFD. Sharp-edged column cross-sections can be realised through the use of chamfer strips. Through the formwork panel arrangement, which is based on the windmill vane principle, both square and rectangular column cross-sections can be formed in 5 cm increments. Appropriate safety equipment is available for ladder access and concreting operations.

System dimensions

Formwork height:

4 different panel heights: 3.30 m, 2.70 m, 1.20 m, 0.60 m.

Column cross-sections

With Column Panel TRS, 90 cm wide: square or rectangular from 20 x 20 cm to 75 x 75 cm in 5 cm increments.

With Column Panel TRS, 120 cm wide: square or rectangular from 20 x 20 cm to 105 x 105 cm in 5 cm increments.

With Column Panel TRS, 90 cm wide and TRS, 120 cm wide: square or rectangular from 20 x 20 cm to 75 x 105 cm in 5 cm increments.

Technical data

For Column Panels TRS, 90 cm wide: permissible fresh concrete pressure 100 kN/m².

For Column Panels TRS, 120 cm wide: permissible fresh concrete pressure 90 kN/m².

For combinations with Column Panels TRS, 90 cm wide and Column Panels TRS, 120 cm wide: permissible fresh concrete pressure 70 kN/m².

Instructions on use

The use in a way not intended, deviating from the standard configuration or the intended use according to the Instructions for Assembly and Use, represents a misapplication with a potential safety risk, e.g. risk of falling.

Only PERI original components may be used. The use of other products and spare parts is not allowed.

Changes to PERI components are not permitted.

Intended use

Product description

1. PERI products have been designed for exclusive use in the industrial and commercial sectors by suitably trained personnel only.
2. These instructions for assembly and use serve as a basis for the project-related risk assessment and the instructions for the provision and use of the system by the contractor (user). However, they do not replace them.
3. Only PERI original components may be used. The use of other products and spare parts represents a misapplication with associated safety risks.

4. The components are to be inspected before each use to ensure that they are in perfect condition and function correctly.
5. Changes to PERI components are not permitted and represent a misapplication with associated safety risks.
6. Safety instructions and permissible loads must be observed at all times.
7. Components provided by the contractor must correspond to the characteristic features required in these Instructions for Assembly and Use as well as all current laws and standards.

- In particular, the following applies if nothing else is specified:
- timber components: Strength Class C24 for Solid Wood EN 338.
 - scaffold tubes: galvanised steel tubes with minimum dimensions of Ø 48.3 x 3.2 mm according to EN 12811-1:2003 4.2.1.2.
 - scaffold tube couplings according to EN 74.
8. Deviations from the standard configuration may only be carried out after a separate risk assessment has been completed by the contractor (user). On this basis, appropriate measures for the working safety and stability are to be implemented.

Cleaning and maintenance instructions

In order to maintain the value and operational readiness of the formwork materials over the long term, clean the panels after each use.

Some repair work may also be inevitable due to the tough working conditions. The following points should help to keep cleaning and maintenance costs as low as possible.

Spray the formwork on both sides with concrete release agent before each use; this allows easier and faster cleaning of the formwork. Spray the concrete release agent very thinly and evenly!

Spray the rear side of the formwork with water immediately after concreting; this avoids any time-consuming and costly cleaning operations.

When used continuously, spray the panel formlining with concrete release agent immediately after striking; then clean by means of a scraper, brush or rubber lip scraper. Important: do not clean formlining made of plywood with high-pressure equipment; this could result in the formlining being damaged.

Fix box-outs and mounting parts with double-headed nails; as a result, the nails can easily be removed later, and damage to the formlining is largely avoided.

Close all unused anchor holes with plugs; this eliminates any subsequent cleaning or repair work. Anchor holes accidentally blocked with concrete are freed by means of a steel pin from the formlining side.

When placing bundles of reinforcement bars or other heavy objects on horizontally-stored formwork elements, suitable support, e.g. square timbers, is to be used; as a result, impressions and damage to the formlining are largely avoided.

Internal concrete vibrators should be fitted with rubber caps if possible; as a result, any damage to the formlining is reduced if the vibrator is accidentally inserted between the reinforcement and formlining.

Never clean powder-coated components, e.g. panels and accessories, with a steel brush or hard metal scraper; this ensures that the powder-coating remains intact.

Use spacers for reinforcement with large-sized supports or extensive areas of support; this largely avoids impressions being formed in the formlining when under load.

Mechanical components, e.g. spindles or gear mechanisms, must be cleaned of dirt or concrete residue before and after use, and then greased with a suitable lubricant.

Provide suitable support for the components during cleaning so that no unintentional change in their position is possible.

Do not clean components suspended on a crane.

Cross-system

General

The contractor must ensure that the Instructions for Assembly and Use supplied by PERI are available at all times and understood by the site personnel.

These Instructions for Assembly and Use can be used as the basis for creating a risk assessment. The risk assessment is compiled by the contractor. However, these Instructions for Assembly and Use do not replace the risk assessment!

Always take into consideration and comply with the safety instructions and permissible loads.

For the application and inspection of PERI products, the current safety regulations and guidelines valid in the respective countries must be observed.

Materials and working areas are to be inspected on a regular basis, especially before each use and assembly, for:

- signs of damage,
- stability and
- function.

Damaged components must be exchanged immediately on site and may no longer be used.

Safety components are to be removed only when they are no longer required.

Components provided by the contractor must conform with the characteristics required in these Instructions for Assembly and Use as well as all valid construction guidelines and standards. Unless otherwise indicated, this applies in particular to:

- timber components: Strength Class C24 for Solid Wood according to EN 338.
- scaffold tubes: galvanised steel tubes with minimum dimensions of Ø 48.3 x 3.2 mm according to EN 12811-1:2003 4.2.1.2.
- scaffold tube couplings according to EN 74.

Deviations from the standard configuration are only permitted after a further risk assessment has been carried out by the contractor.

On the basis of this risk assessment, appropriate measures for working and operational safety as well as stability are to be determined.

Corresponding proof of stability can be provided by PERI on request if the risk assessment and resulting measures to be implemented are made available.

Before and after exceptional occurrences that may have an adverse effect regarding the safety of the formwork system, the contractor must immediately

- create another risk assessment, with appropriate measures for ensuring the stability of the formwork system being carried out based on the results,
- arrange for an extraordinary inspection to be carried out by a competent person qualified to do so. The aim of this inspection is to identify and rectify any damage in good time in order to guarantee the safe use of the formwork system.

Exceptional occurrences can include:

- accidents,
- longer periods of non-use,
- natural events, e.g. heavy rainfall, icing, heavy snowfall, storms or earthquakes.

Assembly, modification and dismantling work

Assembly, modification or dismantling of formwork systems may only be carried out by qualified persons under the supervision of a competent person. The qualified persons must have received appropriate training for the work to be carried out with regard to specific risks and dangers.

On the basis of the risk assessment and the Instructions for Assembly and Use, the contractor must create installation instructions in order to ensure safe assembly, modification and dismantling of the formwork system.

The contractor must ensure that the personal protective equipment required for the assembly, modification or dismantling of the system, e.g.

- safety helmet,
- safety shoes,
- safety gloves,
- safety glasses,

is available and used as intended.

If personal protective equipment against falling from a height (PPE) is required or specified in local regulations, the contractor must determine appropriate attachment points on the basis of the risk assessment.

The PPE against falling to be used is determined by the contractor.

The contractor must

- provide safe working areas for site personnel which are to be reached through the provision of safe access ways. Areas of risk must be cordoned off and clearly marked.
- ensure the stability during all stages of construction, in particular during assembly, modification and dismantling operations.
- ensure and prove that all loads can be safely transferred.

Utilization

Every contractor who uses or allows formwork systems or sections of the formwork to be used, has the responsibility for ensuring that the equipment is in good condition.

If the formwork system is used successively or at the same time by several contractors, the health and safety coordinator must point out any possible mutual hazards and all work must be then coordinated.

System-specific

1. Retract components only when the concrete has sufficiently hardened and the person in charge has given the approval for striking to take place.
2. Anchoring is to take place only if the anchorage has sufficient concrete strength.
3. Only use designated PERI lifting gear.
4. During striking, do not tear off the formwork panels by crane.
5. If a storm warning is given, additional push-pull props are to be attached or other bracing measures are to be carried out along with implementing the details contained in the PERI Design Tables.

Storage and transportation

Store and transport components ensuring that no unintentional change in their position is possible. Detach lifting accessories and slings from the lowered components only if they are in a stable position and no unintentional change is possible.

Do not drop the components.

Use PERI lifting accessories and slings as well as only those load-bearing points provided on the component.

During the moving procedure

- ensure that components are picked up and set down so that unintentional falling over, falling apart, sliding, falling down or rolling is avoided.
- no persons are allowed to remain under the suspended load.

Always guide pre-assembled scaffolding bays, scaffolding units or scaffolding sections with ropes when moving them by crane.

The access areas on the jobsite must be free of obstacles and tripping hazards as well as being slip-resistant.

For transportation, the surface used must have sufficient load-bearing capacity.

Use original PERI storage and transport systems, e.g. crate pallets, pallets or stacking devices.

Panels and accessories



Follow Instructions for Use for PERI Pallets and Stacking Devices!
Manually-created transport units must be correctly stacked and secured!

Transportation

PERI Pallets and Stacking Devices are suitable for lifting by crane or forklift. They can also be moved with the PERI Pallet Lifting Trolley. All Pallets and Stacking Devices can be lifted using both the longitudinal and front sides.

Stacking



Only panels of the same size are to be transported in one stack!

TRIO Column Panels are laid on top of each other to form a stack and then stored as a bundled unit, or four column panels are stored in MAXIMO Stacking Devices.

(Fig. A1.01a + A1.01b) Store individual components in pallets.

(Fig. A1.02)

When using four Lifting Pins TRIO, individual panels can be taken from the stack without requiring a crane and then taken to the place of use.

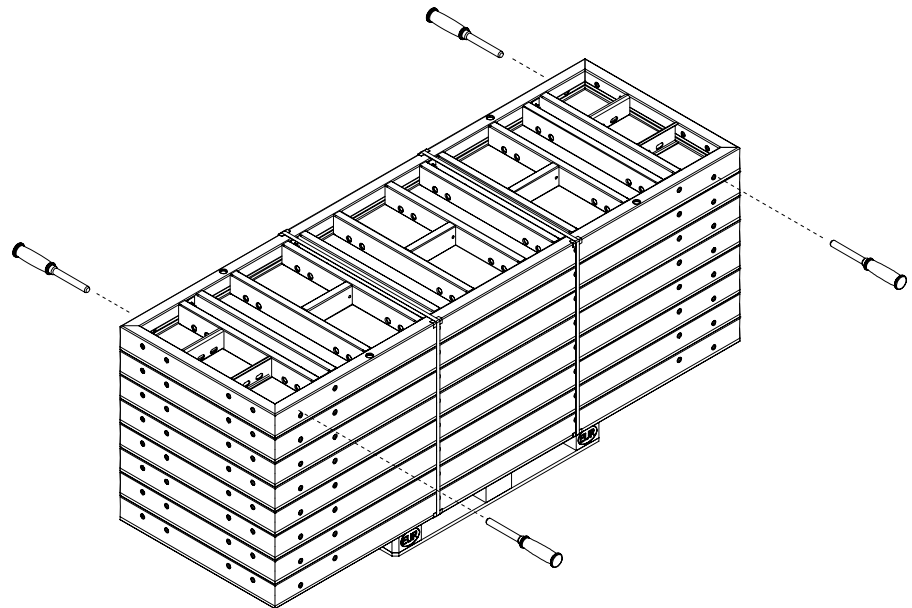

Fig. A1.01a

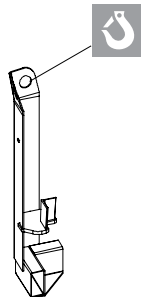

Fig. A1.01b

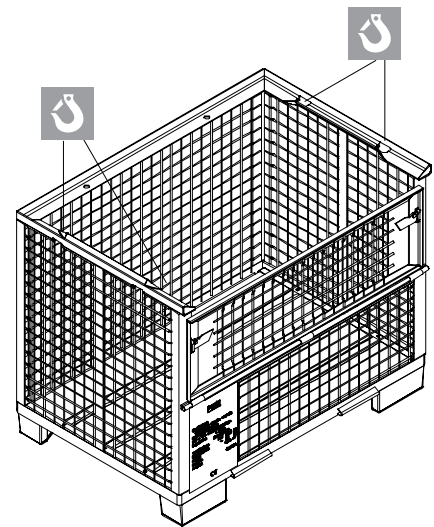

Fig. A1.02

Loading onto trucks

The number of stacks and pallets that can be transported at any one time depends on the respective national traffic regulations.

Tips and information

In order to maintain the value and operational readiness of the TRIO Column Formwork over a long period of time, the formwork should be carefully handled at all times.

Maintenance instructions

1. Concrete vibrator with rubber end cap reduces the risk of damage to the formlining.
2. Spacers used for the reinforcement with large contact surfaces prevent impressions forming on the formlining.
3. When placing heavy items on the formlining, use support timbers in order to prevent any impressions on and damage to the formlining surface.
4. Spray the components with PERI Bio Clean before every use and clean the rear of the formwork with water immediately after concreting.(Fig. A2.01)
5. Spray moving parts, if required, with PERI Bio Clean.
6. For damage-free transportation, suitable PERI Pallets and Stacking Devices are available.



Fig. A2.01

Due to the powder-coated frame, cleaning requirements are kept to a minimum. Therefore, do not remove any concrete residue by means of sharp or pointed objects.

Repairs

The repair of damaged formlining surfaces is done through milling and glueing of repair discs.

Formwork halves

Connection with Column Tie Bolt without the use of ladder access

1. Attach Chamfer Strip (4) to the front side.
2. Place second Column Panel TRS90 / TRS120 (1) on the first Column Panel TRS90 / TRS120 (1.1). (Fig. A3.01)
3. Insert the Column Tie Bolt (2.1) through the panel and tighten it from the outside by means of the Wingnut Pivot Plate (2.2). (Fig. A3.01a)
4. Install the second formwork half in the same way.

Alternatively:
connection with TRS Inserting Nut.

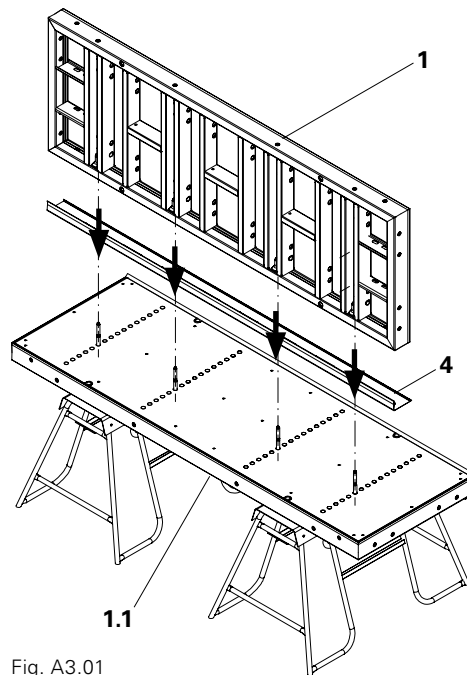

Fig. A3.01

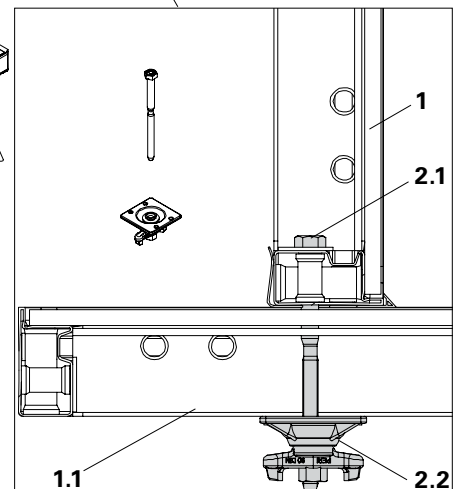
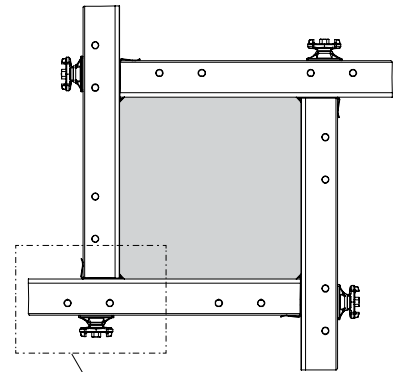

Fig. A3.01a

Connection with TRS Inserting Nut when using ladder access

1. Attach Chamfer Strip (4) on the front side.
2. Place second Column Panel TRS90 / TRS120 (1) on the first Column Panel TRS90 / TRS120 (1.1). (Fig. A3.01)
3. Insert TRS Inserting Nut (2.3) into the perforated strip and secure with bolts and cotter pins.
4. Screw TRS Clamp (2.4) into the Inserting Nut from the outside and tighten. (Fig. A3.01b)
5. Install the second formwork half in the same way.



For connecting the formwork halves with one hand:
Pre-assemble TRS Inserting Nuts at the connection points to the second formwork half.



The following column cross-sections can be formed with the Column Panels TRS90 / TRS120:

- With Column Panel TRS, 90 cm wide: square or rectangular from 20 x 20 cm to 75 x 75 cm in 5 cm increments.
- With Column Panel TRS, 120 cm wide: square or rectangular from 20 x 20 cm to 105 x 105 cm in 5 cm increments. Only possible with the connection variant "Connection with TRS Inserting Nut when using ladder access".
- With Column Panel TRS, 90 cm wide and TRS, 120 cm wide: square or rectangular from 20 x 20 cm to 75 x 105 cm in 5 cm increments.



If two Column Panels TRS, 120 cm wide, are connected together, they may only be connected by means of the connection variant "Connection with TRS Inserting Nut when using ladder access". (Fig. A3.01b)

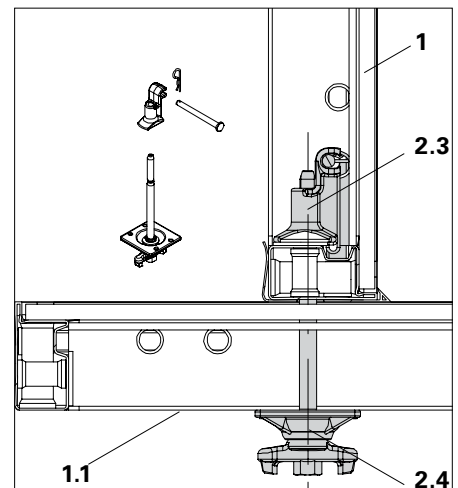

Fig. A3.01b

Push-Pull Props

Assembly on the horizontally-positioned formwork half. Connecting to both horizontal and vertical panel struts is possible. (Fig. A3.02a + A3.02b)



Mount 3 Push-Pull Props and Kickers to ensure stability!

Brace Connector TRIO

Mount six Brace Connectors to one formwork half. (Fig. A3.02)

Assembly

1. Attach Brace Connector (6) to the panel strut so that the Hook Tie (6.1) is securely fixed in a connecting hole.
2. Tighten Brace Connector by means of a Triple Wingnut (6.2). (Fig. A3.02a)
3. Mount Push-Pull Props and Kickers with pins and cotter pins (6.3).
4. Mount Base Plates. (Fig. A3.03)

Push-Pull Props of required length are to be mounted at an angle $\leq 60^\circ$ to the horizontal, see also PERI Design Tables. (Fig. A3.03a)

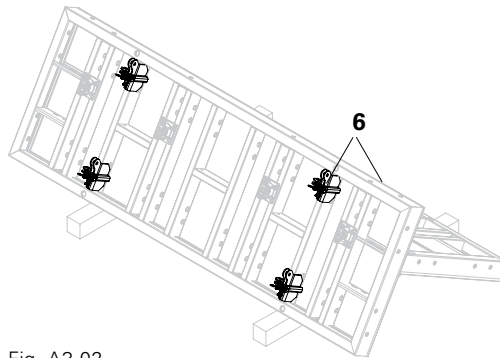

Fig. A3.02

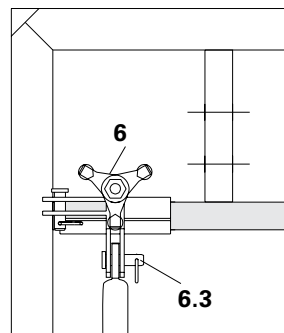
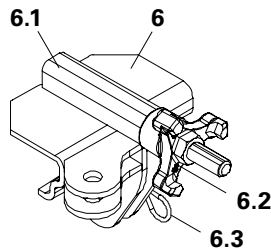

Fig. A3.02a

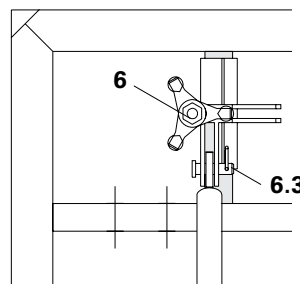
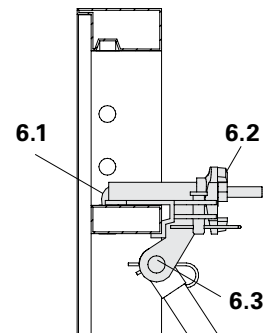

Fig. A3.02b

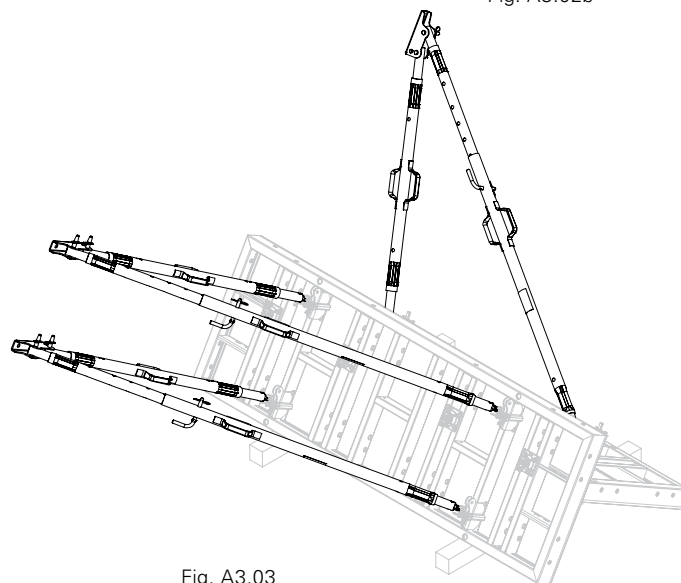
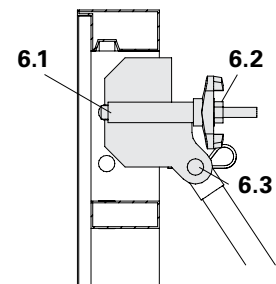

Fig. A3.03

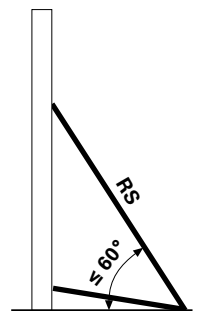

Fig. A3.03a

Concreting platform

Assembly on the horizontally-positioned formwork half.

Assembly

1. Remove Cam Nuts (14) from the Crane Eyes (13).
2. Place platform (11) in an upright position by hand on the formwork half.
3. Insert crane eye bolt through drilled hole a of the column panel and open cam nuts.
4. Proceed in the same way with drilled hole b.
5. Align Telescopic Girder (16) to drilled hole c and mount third crane eye. The extension length of the Telescopic Girder is based on the column cross-section. (Fig. A3.04)
6. Insert guardrails (12). (Fig. A3.05)

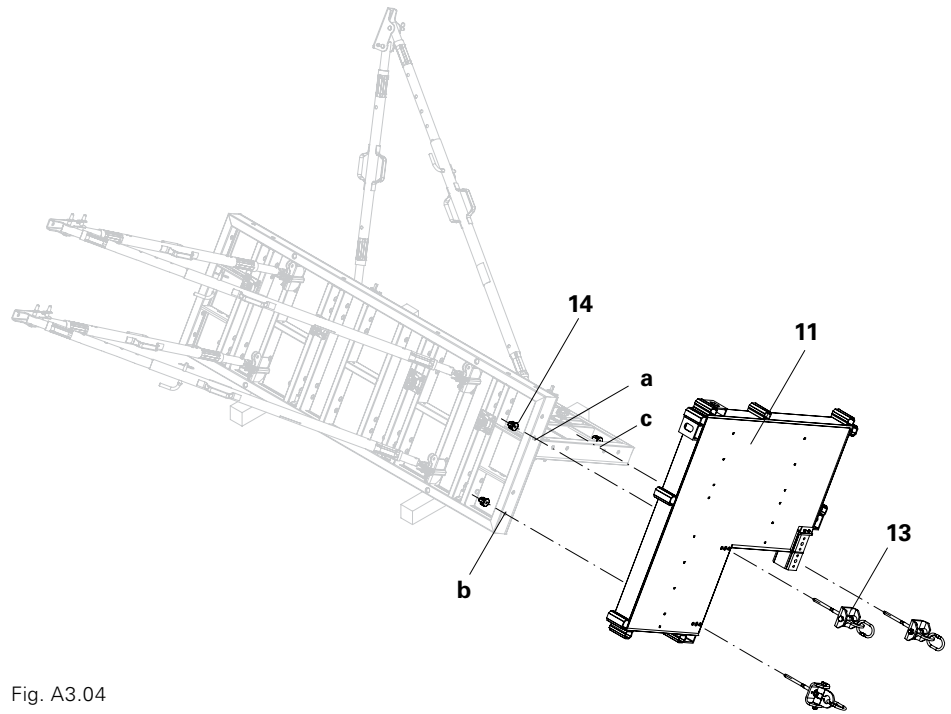

Fig. A3.04

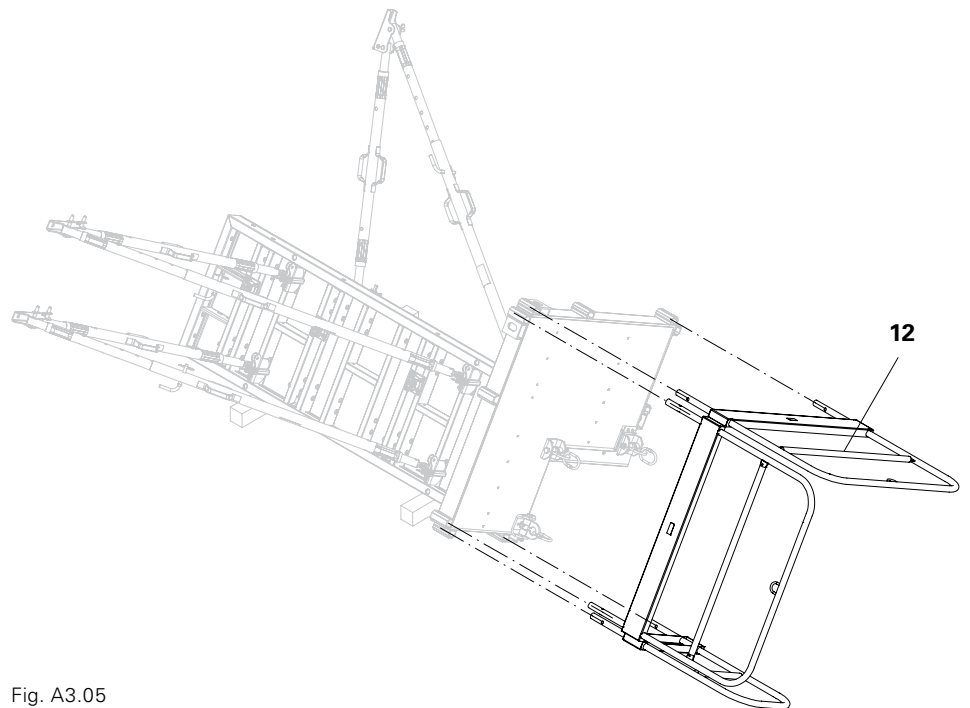

Fig. A3.05

Ladder access for Column Panel TRS90

Assembly on the horizontally-positioned formwork half.



For high columns:
Ladder access is also installed for closing the formwork on the second formwork half. No exit possibility is provided!
(Fig. A3.09)

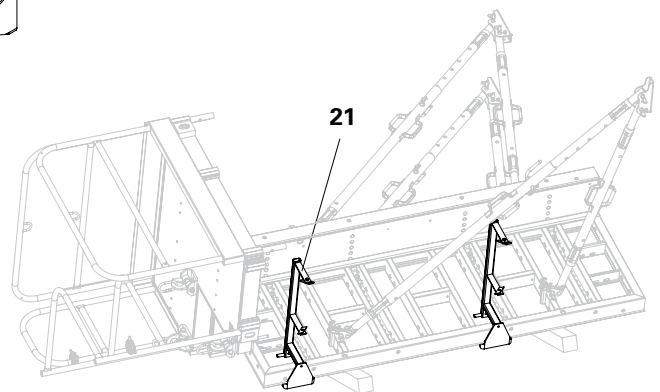
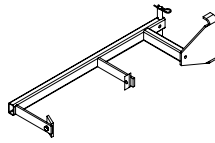

Fig. A3.06

Assembly

1. Place Ladder Connector TRIO (21) on the frame and fix by means of bolting to the panel strut. (Fig. A3.06)
2. Pre-assemble ladder:
 - Connect End Ladder 180/2 (23) to Ladder 180/6 (24), (SW 19). Depending on the height, mount additional Ladders 180/6.
 - Mount Ladder Base (26) and Ladder Hook (25) to the bottom Ladder, (SW 19). (Fig. A3.07)
3. Fix the pre-assembled ladder to the ladder connections by means of Clamping Plates (24.1), (SW 19).
4. Mount Ladder Safety Cage 75 or 150 (27, 28) with Clamping Plates according to plan. Depending on the situation, mount with overlapping ladder joints. (Fig. A3.08) Clear spacing between the Ladder Safety Cages \leq 30 cm.

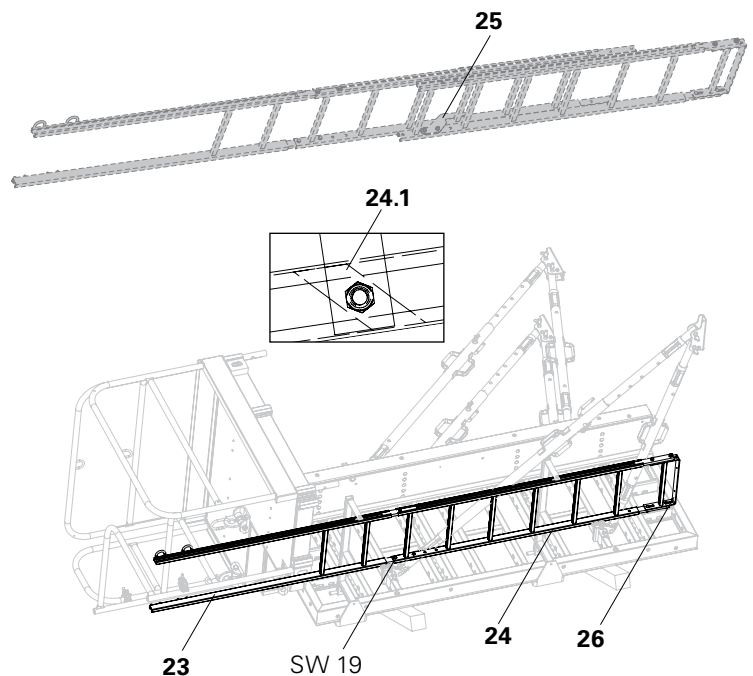

Fig. A3.07



Visual check of the Clamping Plates.
The contact surface must rest against the ladder profile.

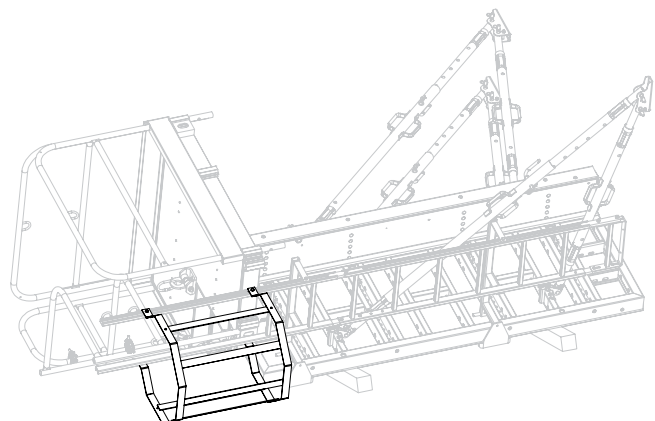

Fig. A3.08

Ladder access for Column Panel TRS90-120

Assembly on the horizontally-positioned formwork half.



For high columns:

Ladder access is also installed for closing the formwork on the second formwork half. No exit possibility is provided!

(Fig. A3.13)



Assembly and use only with safety gloves and safety shoes



The two distance dimensions in the fifth assembly step must be the same!

Only one person may use each ladder at any one time.

Assembly

1. Place Ladder Connector TRS90-120 (22) on the frame and fix by means of bolting to the panel strut. (Fig. A3.10)
2. Pre-assemble ladder:
 - Connect End Ladder 180/2 (23) to Ladder 180/6 (24), (SW 19). Depending on the height, mount additional Ladders 180/6.
 - Mount Ladder Base (26) and Ladder Hooks to the bottom Ladder, (SW 19). (Fig. A3.11)
3. Mount the fixing adapter (22.2) to the pre-assembled ladder by means of Clamping Plates (24.1), (SW 19).
4. Mount the telescopic extension of the ladder connection (22.1) to the fixing adapter by means of three bolts. (Fig. A3.10)

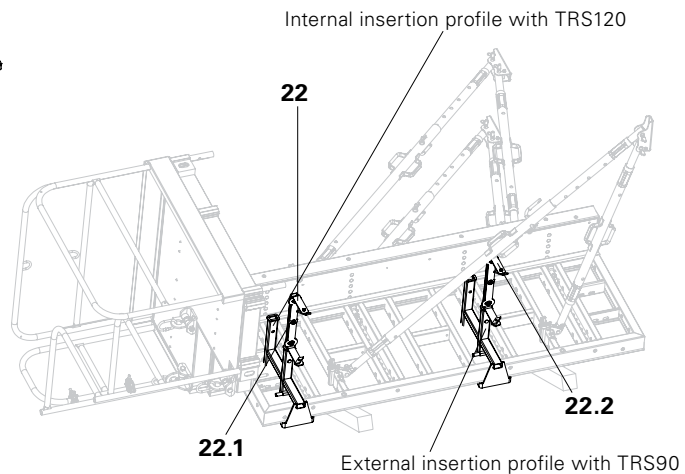
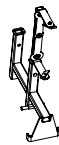

Fig. A3.10

Fig. A3.11a

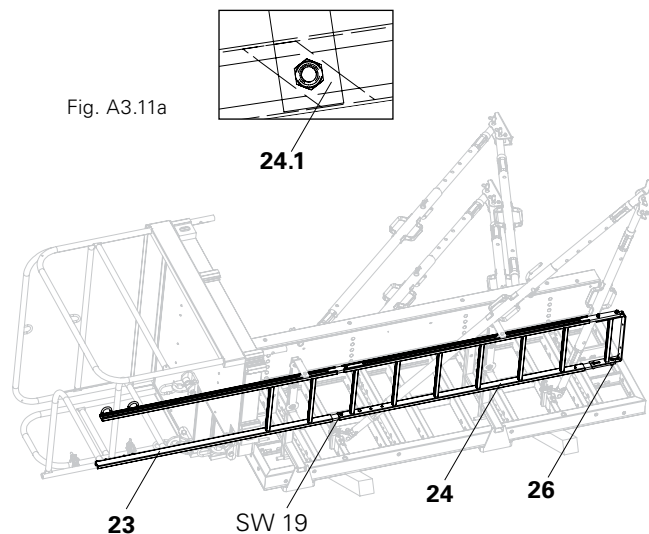

Fig. A3.11

5. Measure the distance between the two external or internal Clamping Plates (24.1). This distance must be equal to the distance between both ladder connections on the column.
6. Insert the telescopic extension of the ladder connection into the Ladder Connection TRS90-120 as follows:
 - For Column Panel TRS90: insert far enough into the external insertion profile of the ladder connection so that the concreting platform can be safely reached via the ladder.
 - For Column Panel TRS120: insert far enough into the internal insertion profile of the ladder connection so that the concreting platform can be safely reached via the ladder. (Fig. A3.10)
7. Fix the telescopic extension with bolts and cotter pins.
8. Mount Ladder Safety Cage 75 or 150 (27, 28) with Clamping Plates according to plan. Depending on the situation, mount with overlapping ladder joints. (Fig. A3.12) Clear spacing between the Ladder Safety Cages \leq 30 cm.

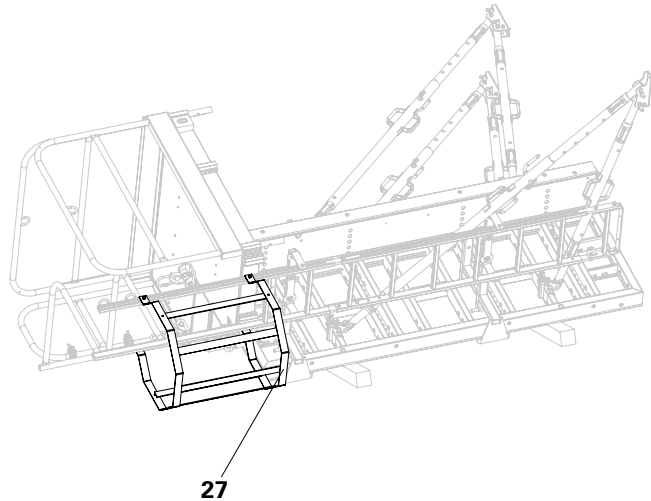

Fig. A3.12



Visual check of the Clamping Plates.
The contact surface must rest against the ladder profile.
The ladder connection must be in the correct insertion profile and fixed to the correct hole.
Securing pins must be in place and secured with cotter pins.

Parts list for access ladders



For higher columns, two access ladders are mounted!



It is possible to mount two concreting platforms.

Ladder access A:

with access to the concreting platform.

Ladder access B:

no access to the concreting platform, only for opening and closing the column formwork.

(Fig. A3.13)

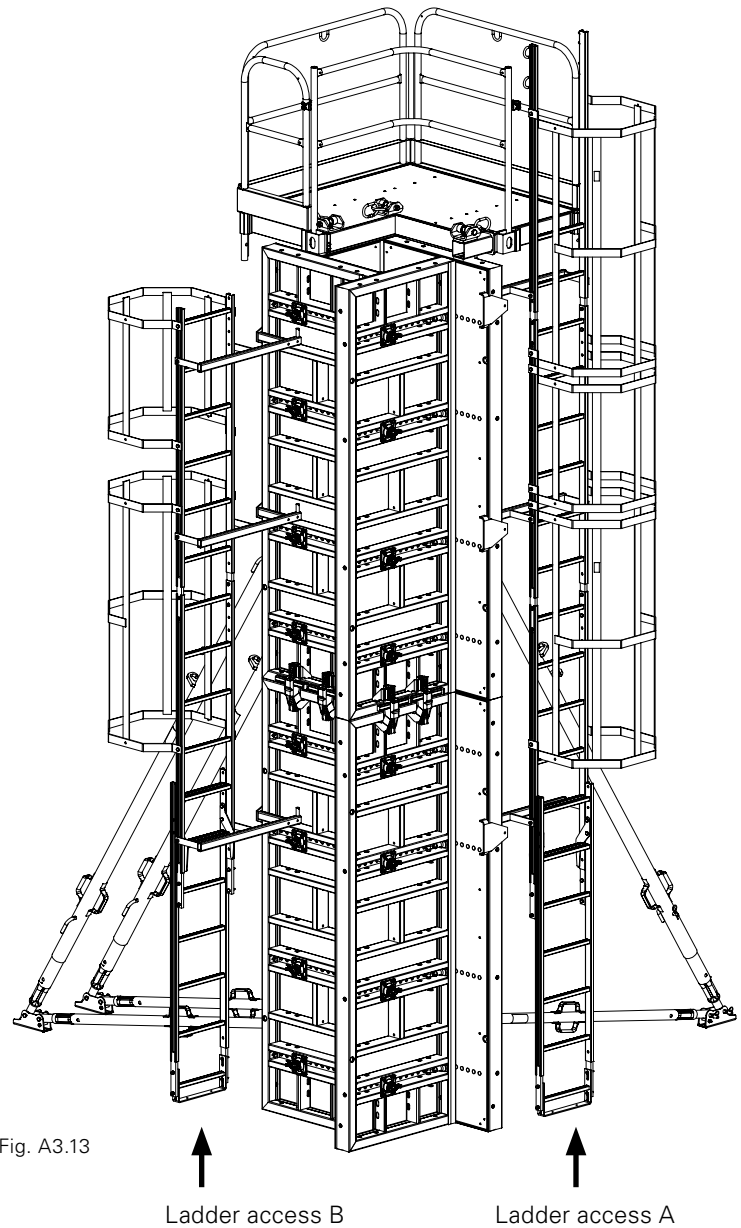

Fig. A3.13

Parts list for one concreting platform and two access ladders

Item no.	Designation	2.70 – 3.60 m		3.90 – 4.20 m		4.50 – 5.70 m		6.00 – 7.50 m		7.80 – 9.30 m		9.60 – 10.80 m	
		A	B	A	B	A	B	A	B	A	B	A	B
037400	Concreting Platform, complete	1	0	1	0	1	0	1	0	1	0	1	0
051410	Ladder 180/6	2	2	2	2	3	3	4	4	5	5	6	6
103724	End Ladder 180/2	1	0	1	0	1	0	1	0	1	2	1	2
051450	Ladder Safety Cage 150	0	0	1	1	2	1	3	3	4	4	5	5
104132	Ladder Safety Cage 75	1	1	1	0	1	1	2	1	2	1	2	1
051460	Ladder Base	1	1	1	1	1	1	1	1	1	1	1	1
103718	Ladder Hook	2	2	2	2	2	2	2	2	2	2	2	2
103362	Ladder Connector TRIO (only for TRS90)	2	2	2	2	3	3	4	4	5	5	6	6
132120	Ladder Connector TRIO TRS90-120	2	2	2	2	3	3	4	4	5	5	6	6
115352	Front Guardrail 86/86	1	0	1	0	1	0	1	0	1	2	1	2

Placing the formwork



- Always set up the formwork half with the concreting platform and Push-Pull Props first.
- Align formwork with the rear side to the locating boards.
- For working areas at great heights, choose a safe working area.

Positioning formwork half with concreting platform and Push-Pull Props (primary formwork)

1. Attach 3-sling lifting gear to the Crane Eyes (13), set formwork upright and then transport to the place of use. (Fig. A4.01)
2. Position formwork half against locating boards (1.2). (Fig. A4.02)

Fig. A4.01

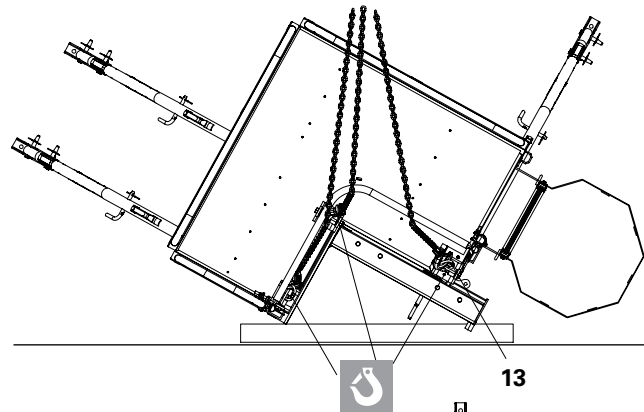
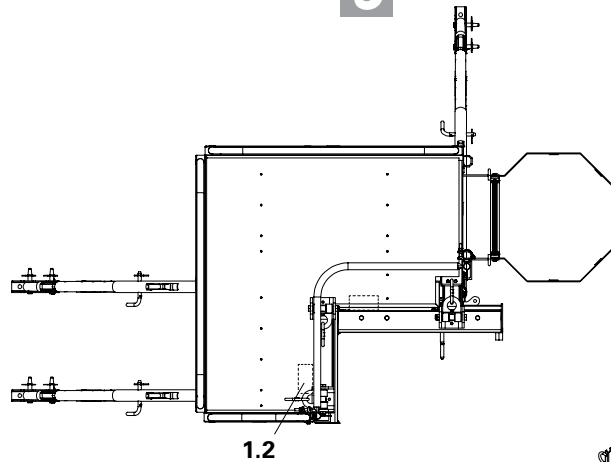

Fig. A4.02



3. Fix Base Plates of Push-Pull Props and Kickers on a sufficiently load-bearing surface area, e.g. using PERI Anchor Bolt 14/20x130, Item no. 124777. (Fig. A4.03a)
4. Check stability and vertically align formwork in both directions.
5. Detach crane lifting gear with site personnel in a safe position.

The first formwork half is now in position. (Fig. A4.03)

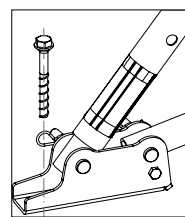

Fig. A4.03a

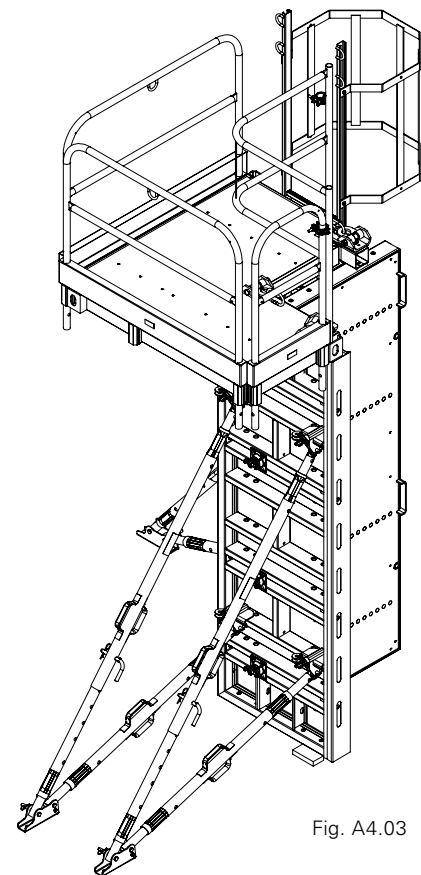

Fig. A4.03

Placing the formwork



Take into consideration Instructions for Use for the Lifting Hook MAXIMO or TRIO!

Positioning the second formwork half (closing formwork)

1. Mount Lifting Hook MAXIMO or TRIO.
2. Align formwork and then transport to place of use.
3. Position formwork half. (Fig. A4.04)

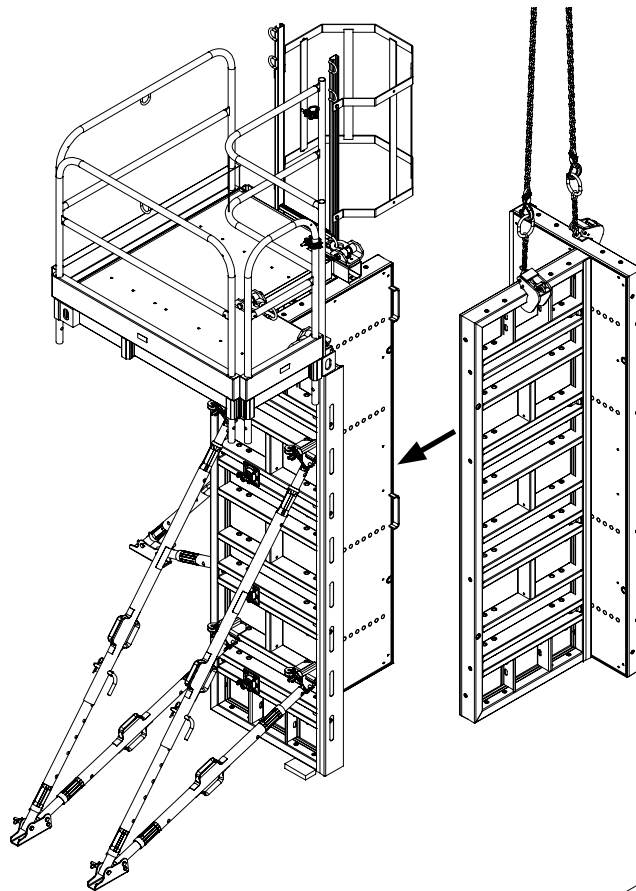

Fig. A4.04

Closing the formwork



- For higher columns, two access ladders are used! Close formwork from bottom to top.
- For working areas at great heights, choose a safe working area.

Connection with TRS Inserting Nut when using ladder access

1. Screw TRS Clamp (2.4) into the TRS Inserting Nut (2.3) from the outside and tighten, see A3 Formwork halves. (Fig. A4.05 + A4.05a)
2. Detach crane lifting gear with site personnel in a safe position.

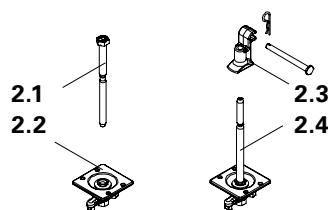

Fig. A4.05a

The formwork is now complete.

Alternatively

however not in connection with two Column Panels TRS, 120 cm wide:

panel connection with Column Tie Bolt (2.1) and Wingnut Pivot Plate (2.2).

If necessary, the Front Guardrail Landing 86/86 (15) can be mounted.

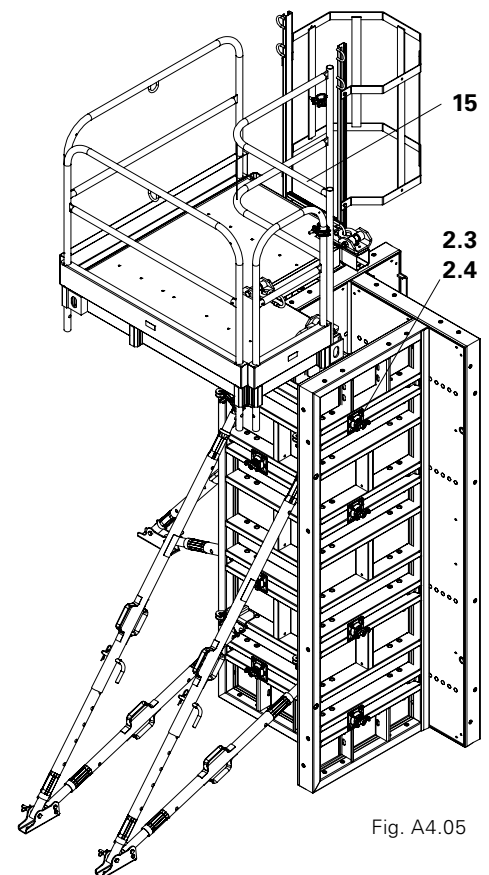

Fig. A4.05

Striking, moving



- Push-Pull Props, concreting platform and ladder access remain attached.
- Open formwork from top to bottom.
- For working areas at great heights, choose a safe working area.

Formwork half without Push-Pull Props

1. Attach crane lifting gear to the Lifting Hook and tension (unsupported formwork half).
2. Separate corner connections between the formwork halves: screw out TRS Clamp. TRS Inserting Nuts remain on the column panel, release Wingnut Pivot Plates, and pull out the Column Tie Bolts. (Fig. A5.01)
3. Place formwork half in position for cleaning.



Use second ladder access.

Formwork half with concreting platform and Push-Pull Props

1. Attach crane lifting gear to the Crane Eyes (13) of the concreting platform. Ensure that there are no persons on the concreting platform or access ladder when implementing additional working steps.
2. Remove Base Plates of the Push-Pull Props and Kickers from the ground.
3. Place formwork half in position for cleaning, and secure. (Fig. A5.01)

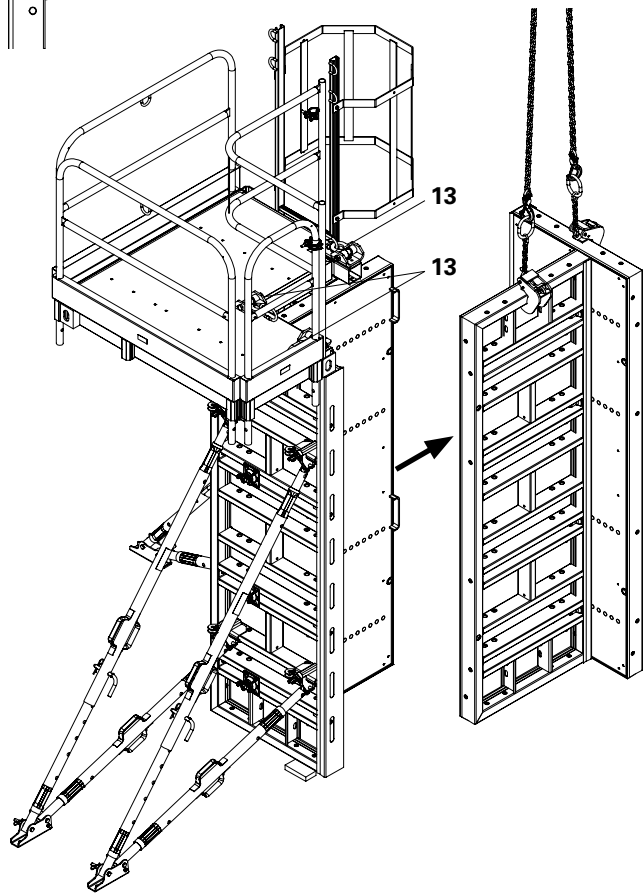
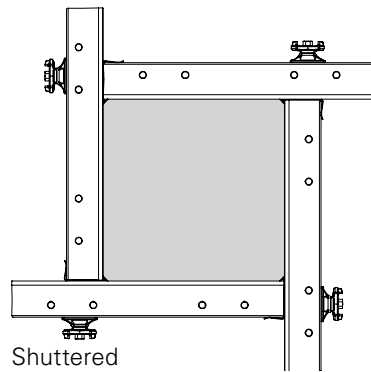
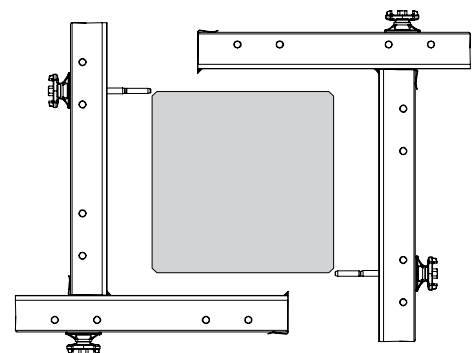

Fig. A5.01



Struck

Height adjustment up to 8.10 m

With four panel heights, height adjustments in 30 cm increments are possible.

Connecting column panels

Connect horizontally-positioned column panels with two PERI Alignment Couplers BFD each.

Formwork height [m]	Required number of column panels			
	330	270	120	60
2.70	–	1	–	–
3.00	–	–	2	1
3.30	1	–	–	–
3.60	–	–	3	–
3.90	1	–	–	1
4.20	–	–	3	1
4.50	1	–	1	–
4.80	–	–	4	–
5.10	1	–	1	1
5.40	–	2	–	–
5.70	1	–	2	–
6.00	1	1	–	–
6.30	–	1	3	–
6.60	2	–	–	–
6.90	1	–	3	–
7.20	1	1	1	–
7.50	–	1	4	–
7.80	–	2	2	–
8.10	–	3	–	–

TRIO Column Formwork



Item no.	Weight kg
054200	140.000

Column Panel TRS 270 x 90

Column panels for cross-sections up to 75 x 75 cm in 5-cm-increments. 18 mm Fin-Ply formlining.

Complete with

64 pc. 030320 Plug Ø 25 mm for TRS

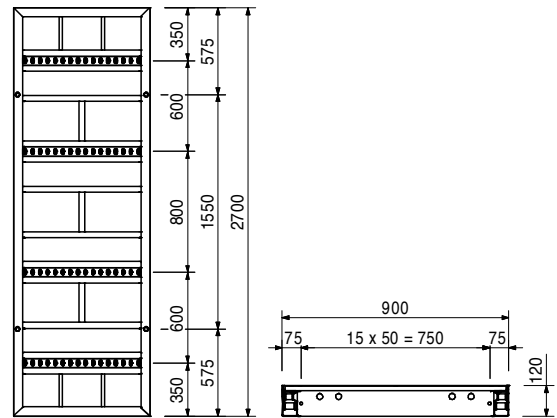
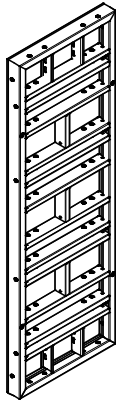

Accessories

030370	1.660
054230	0.584

Wingnut Pivot Plate DW 15, galv.

Column Tie Bolt TRIO, galv.

054210	69.800
--------	--------

Column Panel TRS 120 x 90

Column panels for cross-sections up to 75 x 75 cm in 5-cm-increments. 18 mm Fin-Ply formlining.

Complete with

32 pc. 030320 Plug Ø 25 mm for TRS

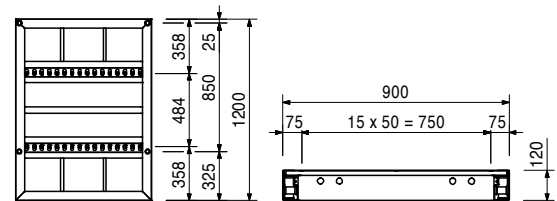
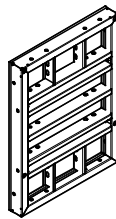

Accessories

030370	1.660
054230	0.584

Wingnut Pivot Plate DW 15, galv.

Column Tie Bolt TRIO, galv.

054220	40.300
--------	--------

Column Panel TRS 60 x 90

Column panels for cross-sections up to 75 x 75 cm in 5-cm-increments. 18 mm Fin-Ply formlining.

Complete with

16 pc. 030320 Plug Ø 25 mm for TRS

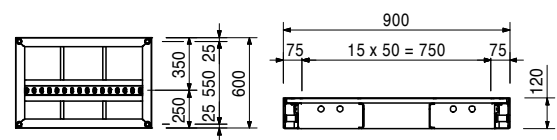
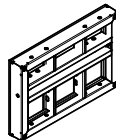

Accessories

030370	1.660
054230	0.584

Wingnut Pivot Plate DW 15, galv.

Column Tie Bolt TRIO, galv.

TRIO Column Formwork



Item no.	Weight kg
130696	259.000

TRIO Column Panel TRS 330 x 120

Column panels for cross-sections up to 105 x 105 cm in 5-cm-increments. 18 mm Fin-Ply formlining.

Complete with

115 pc. 030320 Plug Ø 25 mm for TRS

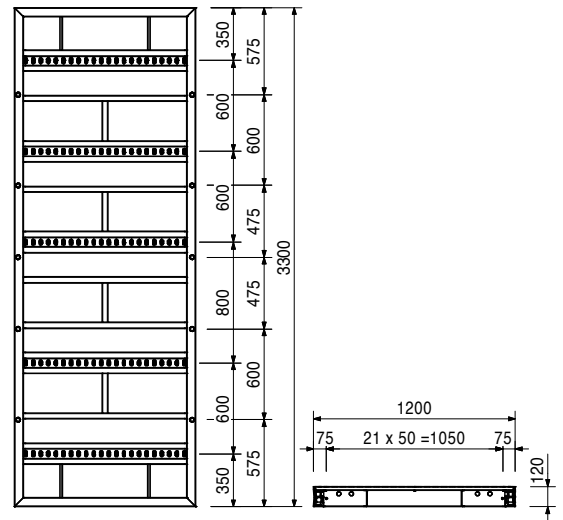
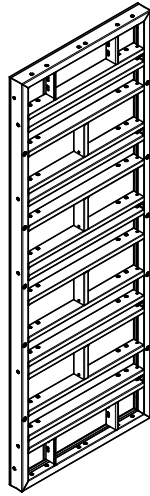

Accessories

030370	1.660
054230	0.584

Wingnut Pivot Plate DW 15, galv.

Column Tie Bolt TRIO, galv.

130666	213.000
--------	---------

TRIO Column Panel TRS 270 x 120

Column panels for cross-sections up to 105 x 105 cm in 5-cm-increments. 18 mm Fin-Ply formlining.

Complete with

88 pc. 030320 Plug Ø 25 mm for TRS

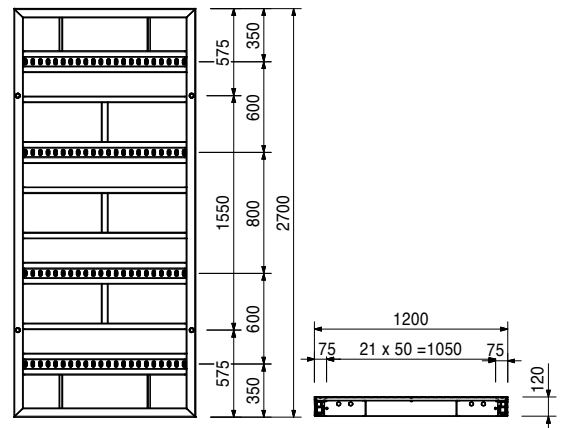
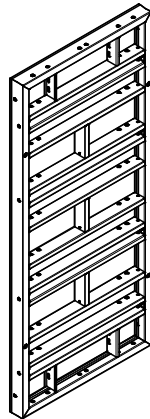

Accessories

030370	1.660
054230	0.584

Wingnut Pivot Plate DW 15, galv.

Column Tie Bolt TRIO, galv.

TRIO Column Formwork



Item no.	Weight kg
130649	130.000

TRIO Column Panel TRS 120 x 120

Column panels for cross-sections up to 105 x 105 cm in 5-cm-increments. 18 mm Fin-Ply formlining.

Complete with

46 pc. 030320 Plug Ø 25 mm for TRS

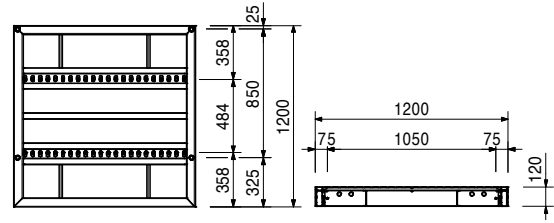
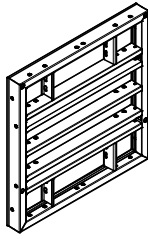

Accessories

030370	1.660
054230	0.584

Wingnut Pivot Plate DW 15, galv.
Column Tie Bolt TRIO, galv.

130704	63.800
--------	--------

TRIO Column Panel TRS 60 x 120

Column panels for cross-sections up to 105 x 105 cm in 5-cm-increments. 18 mm Fin-Ply formlining.

Complete with

25 pc. 030320 Plug Ø 25 mm for TRS

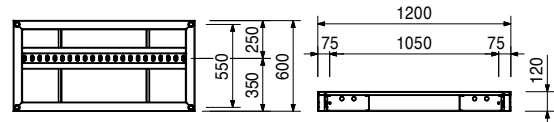
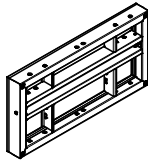

Accessories

030370	1.660
054230	0.584

Wingnut Pivot Plate DW 15, galv.
Column Tie Bolt TRIO, galv.

103716	2.330
--------	-------

TRS Clamp DW 15, galv.

For corner tying of the TRIO Column Panels.

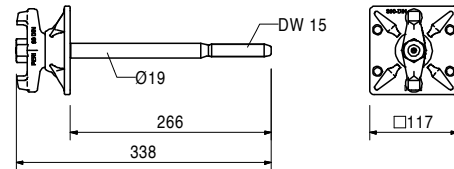
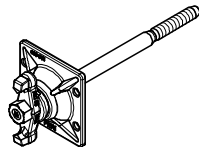

103721	0.823
--------	-------

TRS Inserting Nut, compl.

For corner tying of the TRIO Column Panels.

Complete with

1 pc. 103715 Bolt 14 x 160, galv.

1 pc. 018060 Cotter Pin 4/1, galv.

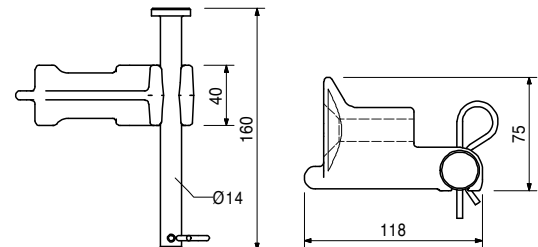
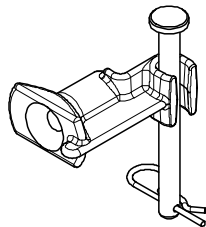

Item no.	Weight kg
054230	0.584

Column Tie Bolt TRIO, galv.
For corner tying of the TRIO Column Panels.

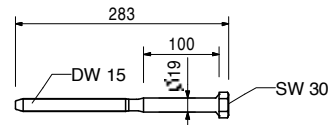
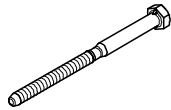

030370	1.660
--------	-------

Wingnut Pivot Plate DW 15, galv.
For anchoring with Tie Rod DW 15 and B 15. With pivoting captive nut. Maximum angle of tilting 8°.

Note
Wrench size SW 27.
Technical Data
Permissible load 90 kN.

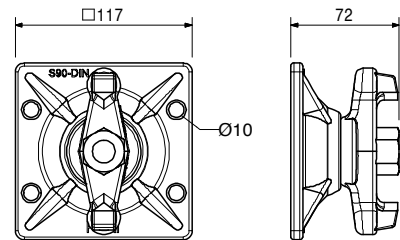
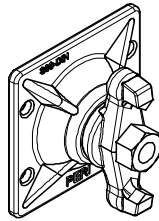

054240	1.900
--------	-------

Chamfer Strip, l = 2.70 m
Chamfer strip made of plastic. For TRIO Column Formwork. Edge length 15 x 15 mm.

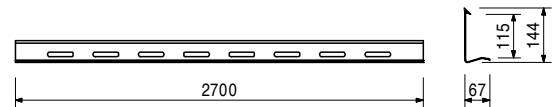
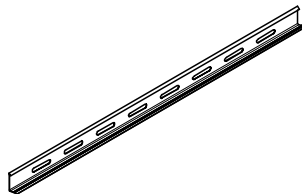

030320	0.004
--------	-------

Plug Ø 25 mm for TRS
For closing unused tie holes Ø 25 mm and with TRIO Column Formwork.

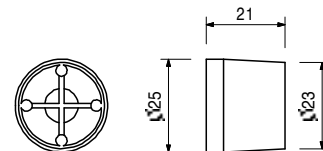
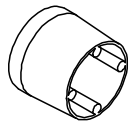

TRIO Column Formwork



Item no.	Weight kg
023500	4.580

Alignment Coupler BFD, galv.

For all panel connections for MAXIMO, TRIO and RUNDFLEX. Fillers up to 10 cm.

Technical Data

Permissible tension force 20.0 kN.

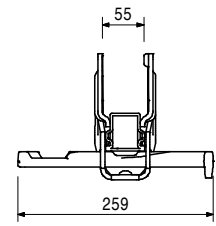
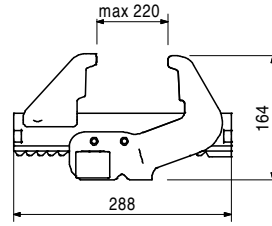
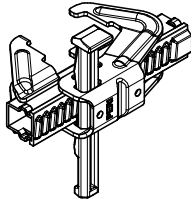

023660	3.300
--------	-------

Brace Connector TRIO, galv.

For connecting push-pull props and kicker braces to MAXIMO and TRIO Panels. Mounted on vertical and horizontal struts.

Complete with

- 1 pc. 027170 Pin Ø 16 x 42, galv.
- 1 pc. 018060 Cotter Pin 4/1, galv.

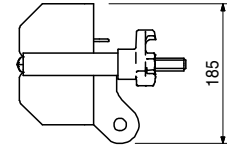
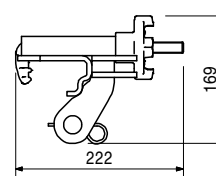
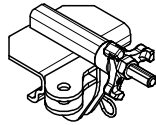

103362	7.120
--------	-------

Ladder Connector TRIO

For connecting ladders to the TRIO Column Panel TRS 90.

Complete with

- 2 pc. 701763 Clamping Plate FI 25 x 10 x 90
- 2 pc. 710266 Bolt ISO 4017 M12 x 25-8.8, galv.
- 1 pc. 018060 Cotter Pin 4/1, galv.

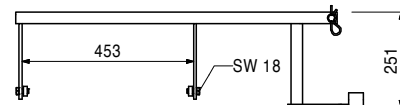
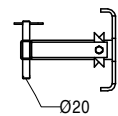
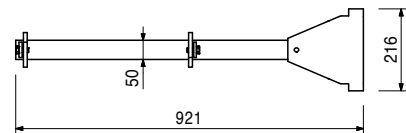
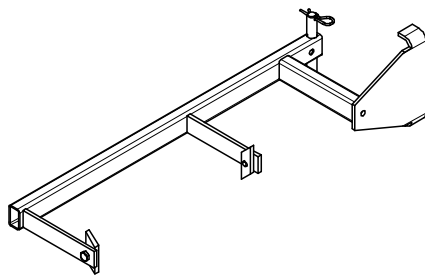

TRIO Column Formwork



Item no.	Weight kg
132120	14.500

Ladder Connector TRIO 90-120
 For connecting ladders to the TRIO Column Panel TRS Column cross-section 90 - 120.

Complete with
 2 pc. 701763 Clamping Plate FI 25 x 10 x 90
 2 pc. 710266 Bolt ISO 4017 M12 x 25-8.8, galv.
 2 pc. 018060 Cotter Pin 4/1, galv.

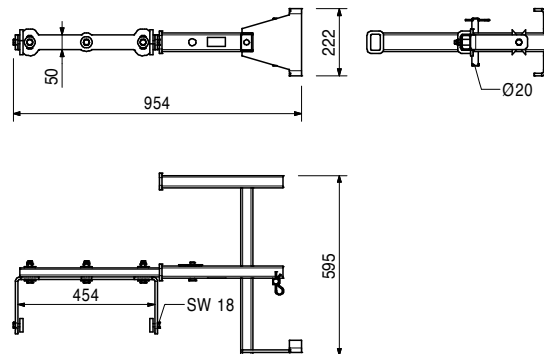
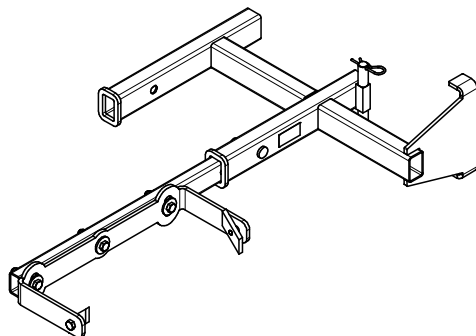

037400	123.000
--------	---------

Concreting Platform, compl.
 Working and concreting platform for TRIO, RAPID and QUATTRO Column Formwork.

Complete with
 1 pc. 037410 Concreting Landing, Alu
 2 pc. 037420 Platform Guardrail 52, galv.
 2 pc. 037430 Platform Guardrail 134, galv.
 3 pc. 037440 Crane Hook Concreting Platform

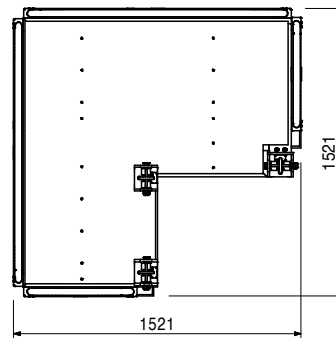
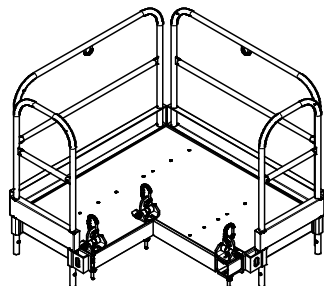

037410	51.400
--------	--------

Concreting Landing, Alu
 Adjusts continuously to all column cross-sections up to max. 60 x 60 cm. Attachment is carried out using the crane eye of the concreting platform.

Technical Data
 Permissible load 150 kg/m².

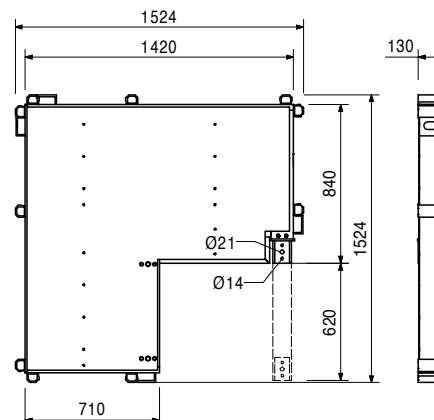
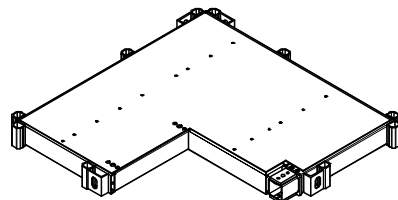

TRIO Column Formwork



Item no.	Weight kg
037420	10.200

Platform Guardrail 52, galv.

As guardrail for PERI Concreting Platforms. Locks in place automatically.

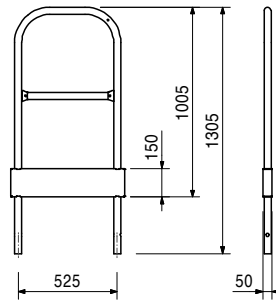
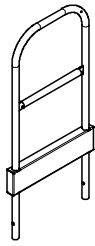

037430	17.100
--------	--------

Platform Guardrail 134, galv.

As guardrail for PERI Concreting Platforms. Locks in place automatically.

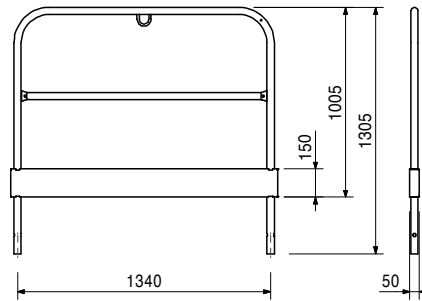
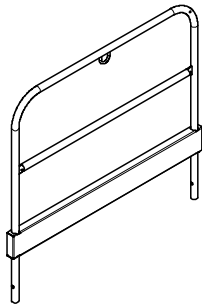

115352	15.300
--------	--------

Platform Front Guardrail 86/86

As guardrail for PERI Concreting Platforms towards the column. Mounted with Screw-on Coupler.

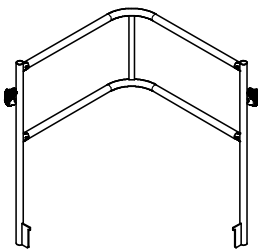

Note
Wrench size SW 19.

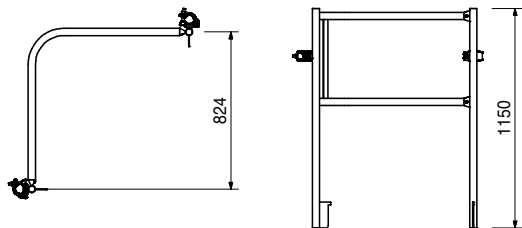

TRIO Column Formwork



Item no.	Weight kg
037440	5.640

Crane Hook Concreting Platform

For assembling the concreting landing to the TRIO, RAPID and QUATTRO column frames.

Note

Follow Instructions for Assembly and Use!

Technical Data

Permissible load-bearing capacity 1.0 t.

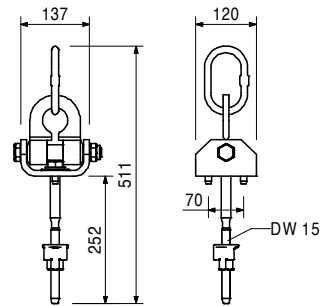
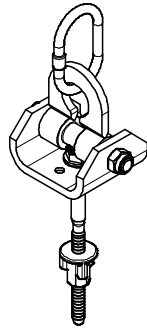

051410	11.700
--------	--------

Ladder 180/6, galv.

As access for PERI Formwork Systems.

Complete with

4 pc. 710224 Bolt ISO 4017 M12 x 40-8.8, galv.

4 pc. 710381 Nut ISO 7042 M12-8, galv.

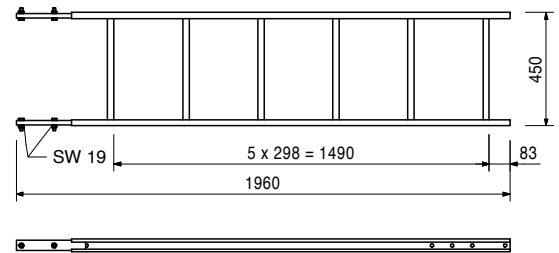
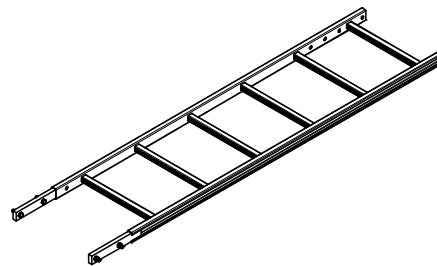

103724	10.400
--------	--------

End Ladder 180/2, galv.

As access for PERI Formwork Systems.

Complete with

4 pc. 710224 Bolt ISO 4017 M12 x 40-8.8, galv.

4 pc. 710381 Nut ISO 7042 M12-8, galv.

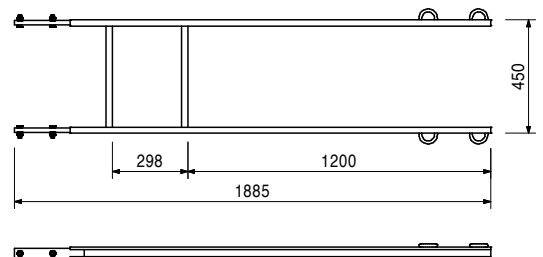
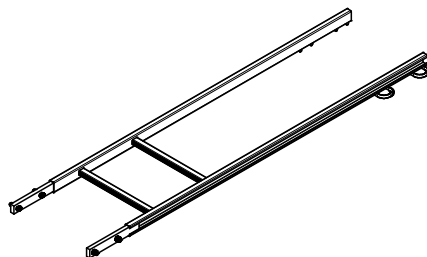

051460	2.180
--------	-------

Ladder Base, galv.

As bottom ladder connection and for securing ladders against sliding on the scaffold decks.

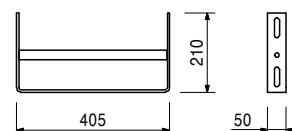
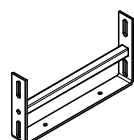

TRIO Column Formwork



Item no.	Weight kg
104132	15.600
051450	25.200

Ladder Safety Cages, galv.
Ladder Safety Cage 75, galv.
Ladder Safety Cage 150, galv.
 Ladder safety cage for PERI Access Ladders.

Complete with
 4 pc. 710266 Bolt ISO 4017 M12 x 25-8.8, galv.
 4 pc. 701763 Clamping Plate FI 25 x 10 x 90

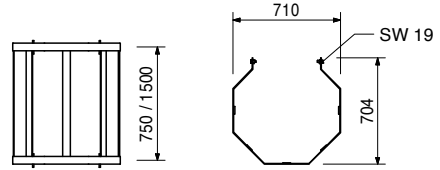
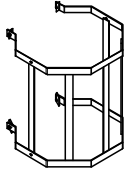

103718	0.684
--------	-------

Ladder Hook, galv.
 For adjusting the bottom ladder.
 Always use in pairs.

Complete with
 2 pc. 710266 Bolt ISO 4017 M12 x 25-8.8, galv.
 2 pc. 710381 Nut ISO 7042 M12-8, galv.

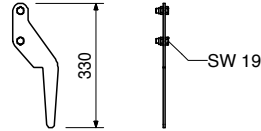

117321	31.000
--------	--------

Lifting Gear Combi MX
 For transporting stacks of MAXIMO and TRIO Panels. For attaching Lifting Hook MAXIMO 1.5 t and Stacking Device MAXIMO.

Note
 Follow Instructions for Use!

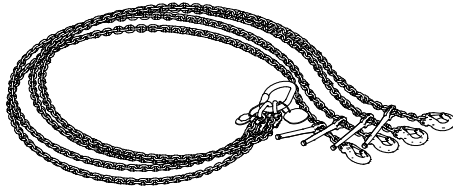

117322	25.000
--------	--------

Lifting Gear MX
 For transporting stacks of MAXIMO and TRIO Panels.

Note
 Follow Instructions for Use!

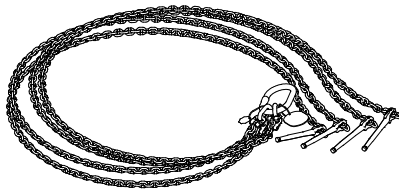

Item no.	Weight kg
115168	7.460

Lifting Hook MAXIMO 1.5 t
For transporting MAXIMO and TRIO Panels.

Note
Follow Instructions for Use!
Technical Data
Permissible load-bearing capacity:
Steel elements 1.5 t
Alu elements 750 kg

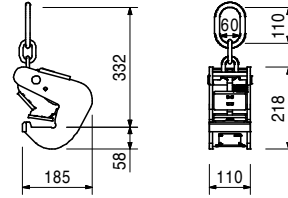
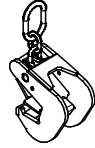

115058	7.450
--------	-------

Stacking Device MAXIMO
For stacking and transportation of 2 – 5 MAXIMO or TRIO Panels of all sizes. Suitable for crane and fork-lift transport.

Note
Follow Instructions for Use!
Technical Data
Permissible load-bearing capacity 650 kg per post, 2.6 t per stack.

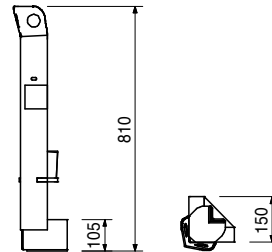
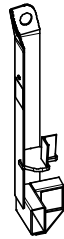

023440	0.312
--------	-------

Lifting Pin TRIO
For easy carrying of TRIO Panels.

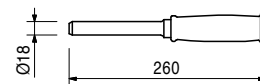
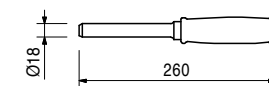

750303	0.014
--------	-------

Stacking Aid TRIO DW 20
Prevents elements sliding and protects the plywood formlining against damage.

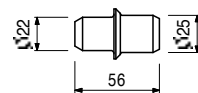

TRIO Column Formwork



Item no.	Weight kg
117466	10.600

Push-Pull Prop RS 210, galv.

Extension length $l = 1.30 - 2.10$ m.
For aligning PERI Formwork Systems and precast concrete elements.

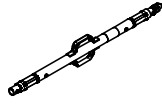

Note

Permissible load see PERI Design Tables.

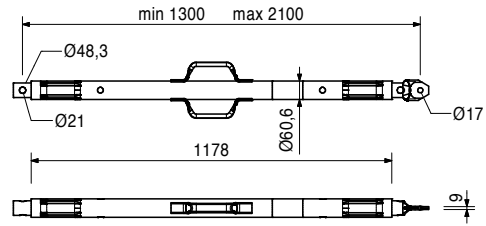

118238	12.100
--------	--------

Push-Pull Prop RS 260, galv.

Extension length $l = 2.30 - 2.60$ m.
For aligning PERI Formwork Systems and precast concrete elements.

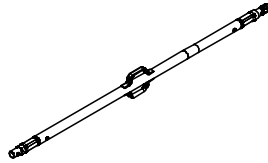

Note

Permissible load see PERI Design Tables.

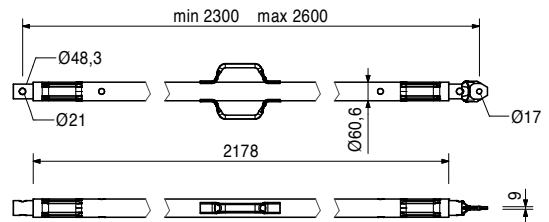

117467	15.500
--------	--------

Push-Pull Prop RS 300, galv.

Extension length $l = 1.90 - 3.00$ m.
For aligning PERI Formwork Systems and precast concrete elements.

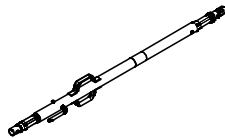

Note

Permissible load see PERI Design Tables.

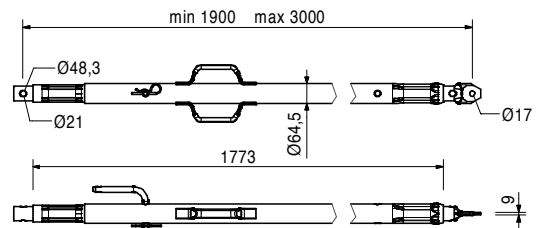

117468	23.000
--------	--------

Push-Pull Prop RS 450, galv.

Extension length $l = 2.80 - 4.50$ m.
For aligning PERI Formwork Systems and precast concrete elements.

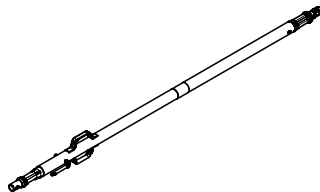

Note

Permissible load see PERI Design Tables.

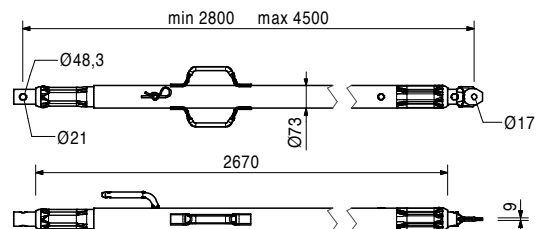

TRIO Column Formwork



Item no.	Weight kg
117469	39.900

Push-Pull Prop RS 650, galv.

Extension length $l = 4.30 - 6.50$ m.
For aligning PERI Formwork Systems and precast concrete elements.

Note

Permissible load see PERI Design Tables.

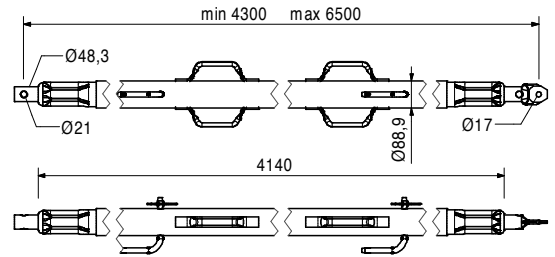
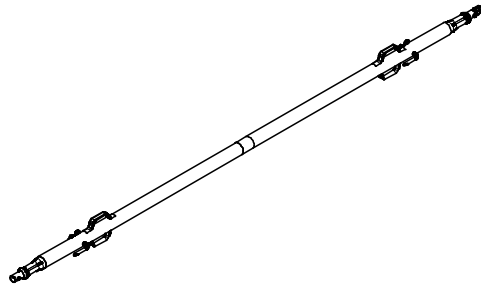

028990	115.000
--------	---------

Push-Pull Prop RS 1000, galv.

Extension length $l = 6.40 - 10.00$ m.
For aligning PERI Formwork Systems.

Note

Permissible load see PERI Design Tables.

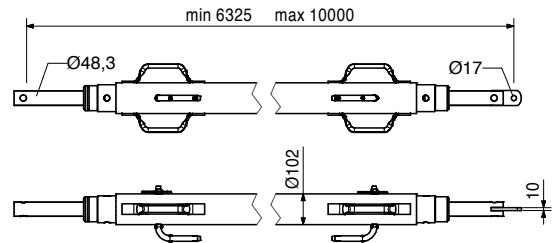
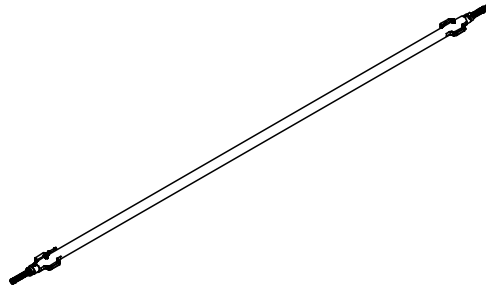

103800	271.000
--------	---------

Push-Pull Prop RS 1400, galv.

Extension length $l = 6.40 - 14.00$ m.
For aligning PERI Formwork Systems.

Note

Permissible load see PERI Design Tables.
Chain can be operated from bottom.

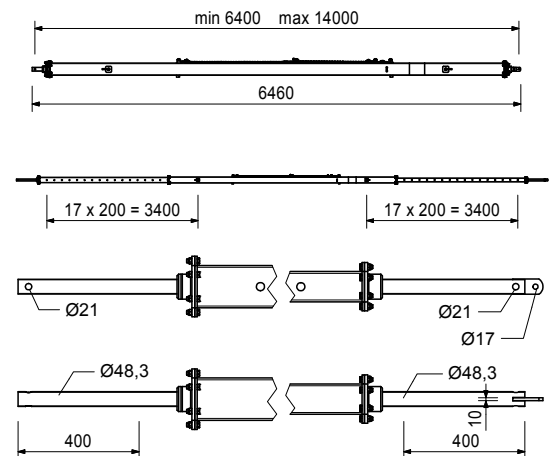
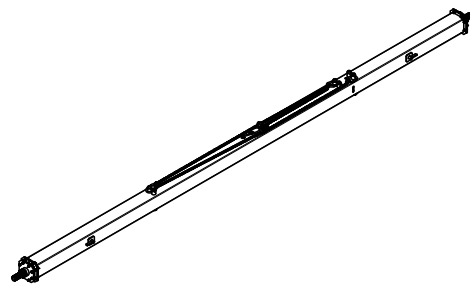

Item no.	Weight kg
126666	3.070

Base Plate-3 for RS 210 - 1400

For assembly of Push-Pull Props RS 210, 260, 300, 450, 650, 1000 and 1400.

Complete with

- 2 pc. 105400 Pin Ø 20 x 140, galv.
- 2 pc. 018060 Cotter Pin 4/1, galv.
- 1 pc. 113063 Bolt ISO 4014 M12 x 80-8.8, galv.
- 1 pc. 113064 Hex Nut ISO7042-M12-8-G, galv.

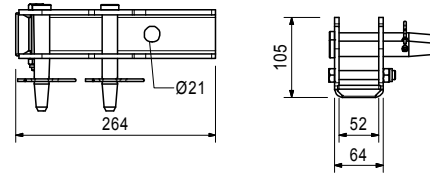
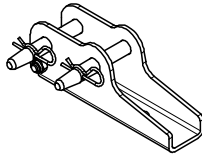

Accessories

124777	0.210
--------	-------

Anchor Bolt PERI 14/20 x 130

102018	4.880
--------	-------

Base Plate-2 for RS 1000/1400, galv.

For assembly of Push-Pull Props RS 210, 260, 300, 450, 650, 1000, 1400 and Heavy Duty Spindles.

Complete with

- 2 pc. 105400 Pin Ø 20 x 140, galv.
- 2 pc. 018060 Cotter Pin 4/1, galv.

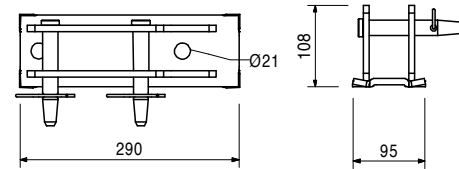
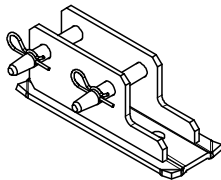

117343	3.250
--------	-------

Base Plate-2 for RS 210 - 1400, galv.

For assembly of Push-Pull Props RS 210, 260, 300, 450, 650, 1000 and 1400.

Complete with

- 2 pc. 105400 Pin Ø 20 x 140, galv.
- 2 pc. 018060 Cotter Pin 4/1, galv.

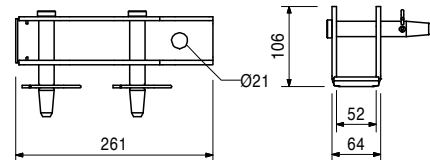
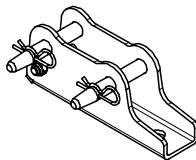

Accessories

124777	0.210
--------	-------

Anchor Bolt PERI 14/20 x 130

028010	17.900
--------	--------

Push-Pull Prop RSS I

Extension length $l = 2.05 - 2.94$ m.
For aligning PERI Formwork Systems.

Note

Permissible load see PERI Design Tables.

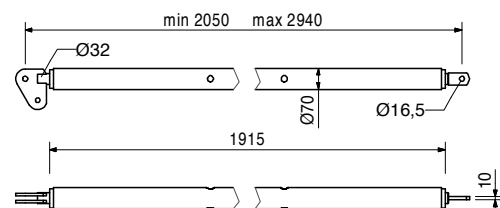
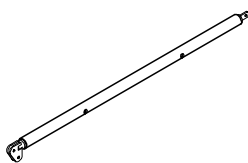

Accessories

113397	1.600
--------	-------

Spindle Handle RSS / AV

Item no.	Weight kg
113397	1.600

Spindle Handle RSS / AV

Spindle handle for screwing on Push-Pull-Props RSS I, RSS II and Kickers AV 210 and AV RSS III.

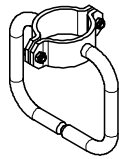

Complete with

2 pc. 722342 Screw ISO 4017 M8 x 25-8.8, galv.
2 pc. 711071 Nut ISO 7042 M8-8, galv.

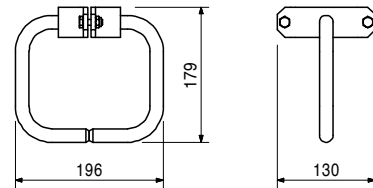

028020	22.000
--------	--------

Push-Pull Prop RSS II

Extension length $l = 2.91 - 3.80$ m.
For aligning PERI Formwork Systems.

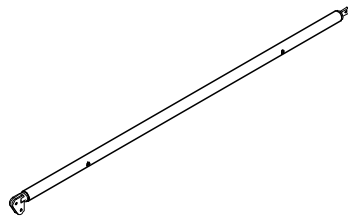

Note

Permissible load see PERI Design Tables.

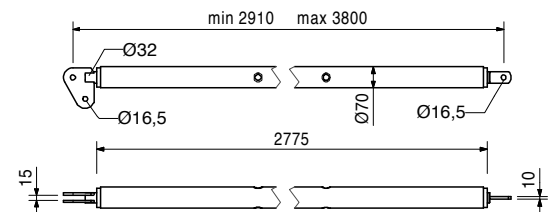

Accessories

113397	1.600
--------	-------

Spindle Handle RSS / AV

028030	38.400
--------	--------

Push-Pull Prop RSS III

Extension length $l = 4.60 - 6.00$ m.
For aligning PERI Formwork Systems.

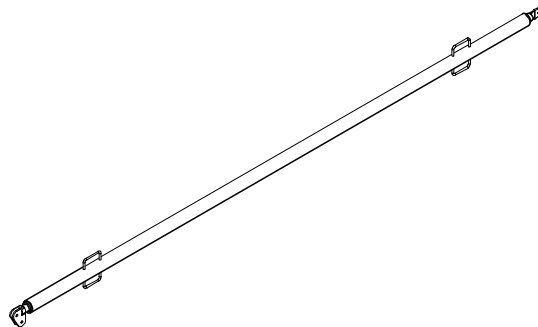

Note

Permissible load see PERI Design Tables.

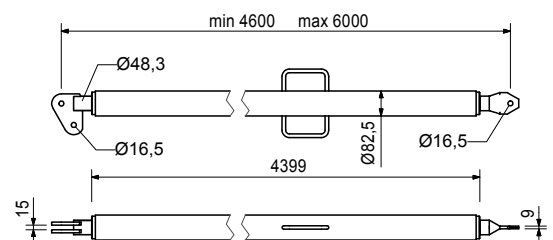

106000	1.820
--------	-------

Base Plate-2 for RSS, galv.

For assembly of Push-Pull Props RSS.

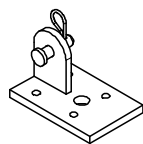

Complete with

1 pc. 027170 Pin $\varnothing 16 \times 42$, galv.
1 pc. 018060 Cotter Pin 4/1, galv.

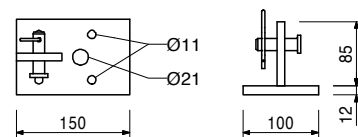

Accessories

124777	0.210
--------	-------

Anchor Bolt PERI 14/20 x 130

Item no.	Weight kg
057087	3.510
057088	4.200

Kickers AV
Kicker AV 82
Kicker AV 111
 For aligning PERI Formwork Systems.

min. L	max. L
500	820
790	1110

Complete with
 1 pc. 027170 Pin Ø 16 x 42, galv.
 1 pc. 018060 Cotter Pin 4/1, galv.

Note
 Permissible load see PERI Design Tables.

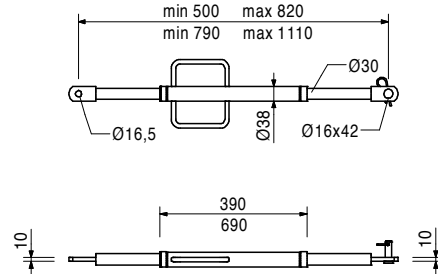
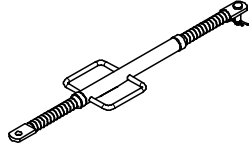

028110	4.850
--------	-------

Kicker AV 140
 Extension length l = 1.08 – 1.40 m.
 For aligning PERI Formwork Systems.

Complete with
 1 pc. 027170 Pin Ø 16 x 42, galv.
 1 pc. 018060 Cotter Pin 4/1, galv.

Note
 Permissible load see PERI Design Tables.

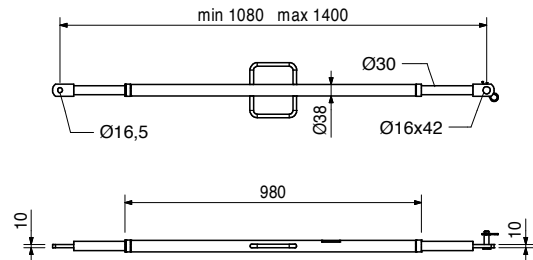
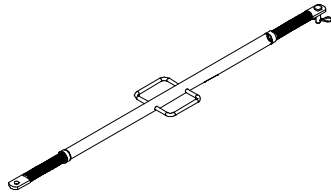

108135	12.900
--------	--------

Kicker AV 210
 Extension length l = 1.28 – 2.10 m.
 For aligning PERI Formwork Systems.

Complete with
 1 pc. 027170 Pin Ø 16 x 42, galv.
 1 pc. 018060 Cotter Pin 4/1, galv.

Note
 Permissible load see PERI Design Tables.

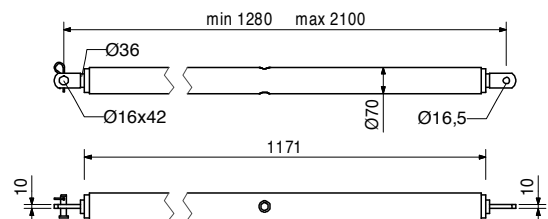
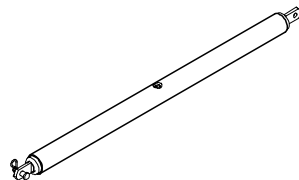

113397	1.600
--------	-------

Accessories
Spindle Handle RSS / AV

Item no.	Weight kg
028120	17.000

Kicker AV RSS III
 Extension length l = 2.03 – 2.92 m.
 For aligning PERI Formwork Systems.

Complete with
 1 pc. 027170 Pin Ø 16 x 42, galv.
 1 pc. 018060 Cotter Pin 4/1, galv.

Note
 Permissible load see PERI Design Tables.

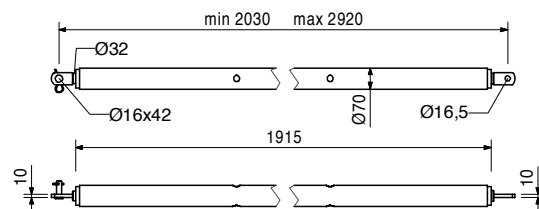
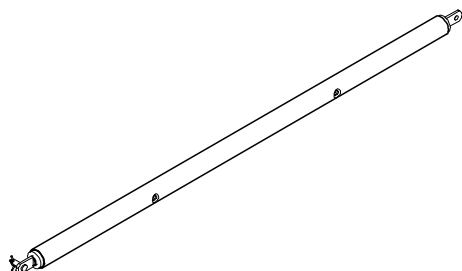

Accessories

113397	1.600
--------	-------

Spindle Handle RSS / AV

028080	2.970
--------	-------

Connector Kicker/Push-Pull Prop, galv.
 For connecting push-pull props and kicker braces to Main Beam HDT.

Complete with
 1 pc. 027170 Pin Ø 16 x 42, galv.
 1 pc. 018060 Cotter Pin 4/1, galv.

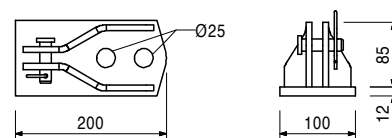
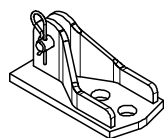

124777	0.210
--------	-------

Anchor Bolt PERI 14/20 x 130
 For temporary fixation to reinforced concrete structures.

Note
 See PERI Data Sheet!
 Drilling Ø 14 mm.

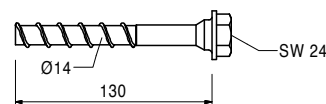
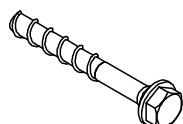

PERI International



North America

- CA** Canada
PERI Formwork Systems, Inc.
www.peri.ca
- MX** Mexico
PERI Cimbras y Andamios, S.A. de C.V.
www.peri.com.mx
- PA** Panama
PERI Panama Inc.
www.peri.com.pa
- US** USA
PERI Formwork Systems, Inc.
www.peri-usa.com

South America

- AR** Argentina
PERI S.A.
www.peri.com.ar
- BR** Brazil
PERI Formas e Escoramentos Ltda.
www.peribrasil.com.br
- CL** Chile
PERI Chile Ltda.
www.peri.cl
- CO** Colombia
PERI S.A.S.
www.peri.com.co
- PE** Peru
PERI Peruana S.A.C.
www.peri.com.pe

Africa

- AO** Angola
Pericofragens, Lda.
www.peri.pt
- DZ** Algeria
S.A.R.L. PERI
www.peri.dz
- EG** Egypt
Egypt Branch Office
www.peri.com.eg
- MA** Morocco
PERI S.A.
www.peri.ma
- MZ** Mozambique
PERI (Pty.) Ltd.
www.peri.co.mz
- NA** Namibia
PERI (Pty.) Ltd.
www.peri.na
- NG** Nigeria
PERI Nigeria Ltd.
www.peri.ng
- TN** Tunisia
PERI S.A.U.
www.peri.es
- TZ** Tanzania
PERI Formwork and Scaffolding Ltd
www.peri.co.tz
- ZA** South Africa
PERI Formwork Scaffolding (Pty) Ltd
www.peri.co.za

Asia

- AE** United Arab Emirates
PERI (L.L.C.)
www.peri.ae
- AZ** Azerbaijan
PERI Representative Office
www.peri.com.tr
- HK** Hong Kong
PERI (Hong Kong) Limited
www.perihk.com
- ID** Indonesia
PT Beton Perkasa Wijaksana
www.betonperkasa.com
- IL** Israel
PERI F.E. Ltd.
www.peri.co.il
- IN** India
PERI (India) Pvt Ltd
www.peri.in
- IR** Iran
PERI Pars. Ltd.
www.peri.ir
- JO** Jordan
PERI GmbH – Jordan
www.peri.com
- JP** Japan
PERI Japan K.K.
www.peri.co.jp
- KR** Korea
PERI (Korea) Ltd.
www.perikorea.com
- KW** Kuwait
PERI Kuwait W.L.L.
www.peri.com.kw
- KZ** Kazakhstan
TOO PERI Kazakhstan
www.peri.kz
- LB** Lebanon
PERI Lebanon Sarl
lebanon@peri.de
- MY** Malaysia
PERI Formwork Malaysia Sdn. Bhd.
www.perimalaysia.com
- OM** Oman
PERI (L.L.C.)
www.peri.ae
- PH** Philippines
PERI-Asia Philippines, INC.
www.peri.com.ph
- QA** Qatar
PERI Qatar LLC
www.peri.qa
- SA** Saudi Arabia
PERI Saudi Arabia Ltd.
www.peri.com.sa
- SG** Singapore
PERI Asia Pte Ltd
www.periasia.com
- TH** Thailand
Peri (Thailand) Co., Ltd.
www.peri.co.th
- TR** Turkey
PERI Kalıp ve İskeleleri
www.peri.com.tr
- VN** Vietnam
PERI ASIA PTE LTD
www.peri.com.vn



PERI

**PERI GmbH
Formwork Scaffolding Engineering**

Rudolf-Diesel-Strasse 19
89264 Weissenhorn
Germany
Tel. +49 (0)7309.950-0
Fax +49 (0)7309.951-0
info@peri.com
www.peri.com

Oceania

AU Australia
PERI Australia Pty. Ltd.
www.periaus.com.au

DK Denmark
PERI Danmark A/S
www.peri.dk

IT Italy
PERI S.r.l.
www.peri.it

SE Sweden
PERI Sverige AB
www.peri.se

Europe

EE Estonia
PERI AS
www.peri.ee

LT Lithuania
PERI UAB
www.peri.lt

SI Slovenia
PERI oplate i skele d.o.o
www.peri.com.hr

AL Albania
PERI Kalıp ve İskeleleri
www.peri.com.tr

ES Spain
PERI S.A.U.
www.peri.es

LU Luxembourg
N.V. PERI S.A.
www.peri.lu

SK Slovakia
PERI spol. s. r.o.
www.peri.sk

AT Austria
PERI Ges.mBH
www.peri.at

FI Finland
PERI Suomi Ltd. Oy
www.perisuomi.fi

LV Latvia
PERI SIA
www.peri-latvija.lv

UA Ukraine
TOW PERI
www.peri.ua

BA Bosnia and Herzegovina
PERI oplate i skele d.o.o
www.peri.com.hr

FR France
PERI S.A.S.
www.peri.fr

NL Netherlands
PERI b.v.
www.peri.nl

BE Belgium
PERI N.V.
www.peri.be

GB United Kingdom
PERI Ltd.
www.peri.ltd.uk

NO Norway
PERI Norge AS
www.peri.no

BG Bulgaria
PERI Bulgaria EOOD
www.peri.bg

GR Greece
PERI Hellas Ltd.
www.perihellas.gr

PL Poland
PERI Polska Sp. z o.o.
www.peri.com.pl

BY Belorussia
IOOO PERI
www.peri.by

HR Croatia
PERI oplate i skele d.o.o.
www.peri.com.hr

PT Portugal
Pericofragens Lda.
www.peri.pt

CH Switzerland
PERI AG
www.peri.ch

HU Hungary
PERI Kft.
www.peri.hu

RO Romania
PERI România SRL
www.peri.ro

CZ Czech Republic
PERI spol. s r.o.
www.peri.cz

IR Ireland
Siteserv Access & Formwork
www.siteservaccess.ie

RS Serbia
PERI oplate d.o.o.
www.peri.rs

DE Germany
PERI GmbH
www.peri.de

IS Iceland
Armar ehf.
www.armor.is

RU Russia
OOO PERI
www.peri.ru

**The optimal System
for every Project and
every Requirement**



Wall Formwork



Column Formwork



Slab Formwork



Climbing Systems



Bridge Formwork



Tunnel Formwork



Shoring Systems



Construction Scaffold



Facade Scaffold



Industrial Scaffold



Access



Protection Scaffold



Safety Systems



System-Independent Accessories



Services



PERI GmbH
Formwork Scaffolding Engineering
 Rudolf-Diesel-Strasse 19
 89264 Weissenhorn
 Germany
 Tel. +49 (0)7309.950-0
 Fax +49 (0)7309.951-0
 info@peri.com
 www.peri.com

